

Drawings

EJA438E Diaphragm Sealed Pressure Transmitter (Diaphragm seal section, Flush type with ring)



SD 01C31J04-11EN

[Style: S1, S2]

- Flushing connection ring code A, B, C and D (With ring)

Unit: mm (approx. inch)

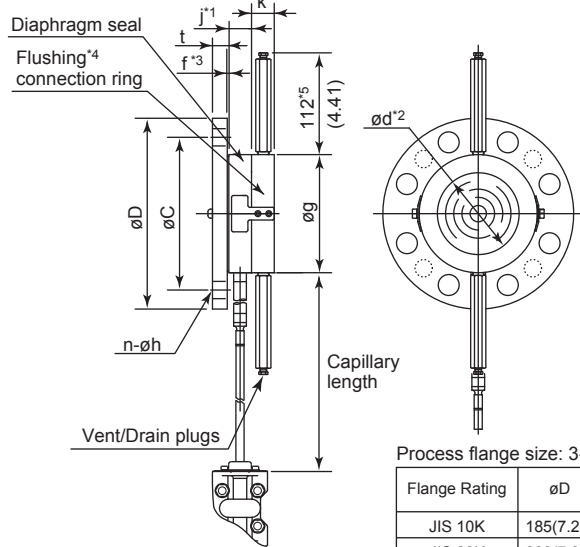

- *1: When wetted parts material code UW (titanium), value is 34 (1.34).
- *2: Indicates inside diameter of gasket contact surface.
- *3: In case where process flange material is JIS S25C, value of f is 0.

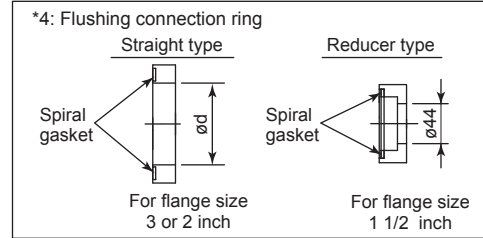

- *4: Flushing connection ring
- *5: When option code K1 or K5 is selected, add 11 mm (0.43 inch).

Process flange size: 3-inch (80mm)

Flange Rating	øD	øC	øg	ød	t	f	Bolt holes		j	k
							No.(n)	Dia.(øh)		
JIS 10K	185(7.28)	150(5.91)	130(5.12)	90(3.54)	18(0.71)	0	8	19(0.75)	25(0.98)	27(1.06)
JIS 20K	200(7.87)	160(6.30)	130(5.12)	90(3.54)	22(0.87)	0	8	23(0.91)	25(0.98)	27(1.06)
JIS 40K	210(8.27)	170(6.69)	130(5.12)	90(3.54)	32(1.26)	0	8	23(0.91)	25(0.98)	27(1.06)
JIS 63K	230(9.06)	185(7.28)	130(5.12)	90(3.54)	40(1.57)	0	8	25(0.98)	25(0.98)	27(1.06)
ANSI Class 150	190.5(7.50)	152.4(6.00)	130(5.12)	90(3.54)	23.9(0.94)	1.6(0.06)	4	19.1(0.75)	25(0.98)	27(1.06)
ANSI Class 300	209.6(8.25)	168.1(6.62)	130(5.12)	90(3.54)	28.5(1.12)	1.6(0.06)	8	22.4(0.88)	25(0.98)	27(1.06)
ANSI Class 600	209.6(8.25)	168.1(6.62)	130(5.12)	90(3.54)	38.2(1.50)	6.4(0.25)	8	22.4(0.88)	25(0.98)	27(1.06)
JPI Class 150	190(7.48)	152.4(6.00)	130(5.12)	90(3.54)	24(0.94)	1.6(0.06)	4	19(0.75)	25(0.98)	27(1.06)
JPI Class 300	210(8.27)	168.1(6.62)	130(5.12)	90(3.54)	28.5(1.12)	1.6(0.06)	8	22(0.87)	25(0.98)	27(1.06)
JPI Class 600	210(8.27)	168.1(6.62)	130(5.12)	90(3.54)	38.4(1.51)	6.4(0.25)	8	22(0.87)	25(0.98)	27(1.06)
DIN PN 10/16	200(7.87)	160(6.30)	130(5.12)	90(3.54)	20(0.79)	0	8	18(0.71)	25(0.98)	27(1.06)
DIN PN 25/40	200(7.87)	160(6.30)	130(5.12)	90(3.54)	24(0.94)	0	8	18(0.71)	25(0.98)	27(1.06)
DIN PN 64	215(8.46)	170(6.69)	130(5.12)	90(3.54)	28(1.10)	0	8	22(0.87)	25(0.98)	27(1.06)

Process flange size: 2-inch (50mm)

Flange Rating	øD	øC	øg	ød	t	f	Bolt holes		j	k
							No.(n)	Dia.(øh)		
JIS 10K	155(6.10)	120(4.72)	100(3.94)	61(2.40)	16(0.63)	0	4	19(0.75)	25(0.98)	27(1.06)
JIS 20K	155(6.10)	120(4.72)	100(3.94)	61(2.40)	18(0.71)	0	8	19(0.75)	25(0.98)	27(1.06)
JIS 40K	165(6.50)	130(5.12)	100(3.94)	61(2.40)	26(1.02)	0	8	19(0.75)	25(0.98)	27(1.06)
JIS 63K	185(7.28)	145(5.71)	100(3.94)	61(2.40)	34(1.34)	0	8	23(0.91)	25(0.98)	27(1.06)
ANSI Class 150	152.4(6.00)	120.7(4.75)	100(3.94)	61(2.40)	19.1(0.75)	1.6(0.06)	4	19.1(0.75)	25(0.98)	27(1.06)
ANSI Class 300	165.1(6.50)	127(5.00)	100(3.94)	61(2.40)	22.4(0.88)	1.6(0.06)	8	19.1(0.75)	25(0.98)	27(1.06)
ANSI Class 600	165.1(6.50)	127(5.00)	100(3.94)	61(2.40)	31.8(1.25)	6.4(0.25)	8	19.1(0.75)	25(0.98)	27(1.06)
JPI Class 150	152(5.98)	120.6(4.75)	100(3.94)	61(2.40)	19.5(0.77)	1.6(0.06)	4	19(0.75)	25(0.98)	27(1.06)
JPI Class 300	165(6.50)	127(5.00)	100(3.94)	61(2.40)	22.5(0.89)	1.6(0.06)	8	19(0.75)	25(0.98)	27(1.06)
JPI Class 600	165(6.50)	127(5.00)	100(3.94)	61(2.40)	31.9(1.26)	6.4(0.25)	8	19(0.75)	25(0.98)	27(1.06)
DIN PN 10/16	165(6.50)	125(4.92)	100(3.94)	61(2.40)	18(0.71)	0	4	18(0.71)	25(0.98)	27(1.06)
DIN PN 25/40	165(6.50)	125(4.92)	100(3.94)	61(2.40)	20(0.79)	0	4	18(0.71)	25(0.98)	27(1.06)
DIN PN 64	180(7.09)	135(5.31)	100(3.94)	61(2.40)	26(1.02)	0	4	22(0.87)	25(0.98)	27(1.06)

Process flange size: 1 1/2-inch (40mm)

Flange Rating	øD	øC	øg	ød	t	f	Bolt holes		j	k
							No.(n)	Dia.(øh)		
JIS 10K	140(5.51)	105(4.13)	86(3.38)	44(1.73)	16(0.63)	0	4	19(0.75)	27(1.06)	30(1.18)
JIS 20K	140(5.51)	105(4.13)	86(3.38)	44(1.73)	18(0.71)	0	4	19(0.75)	27(1.06)	30(1.18)
JIS 40K	160(6.30)	120(4.72)	86(3.38)	44(1.73)	24(0.94)	0	4	23(0.88)	27(1.06)	30(1.18)
ANSI Class 150	127(5.00)	98.6(3.88)	86(3.38)	44(1.73)	17.5(0.69)	1.6(0.06)	4	15.7(0.62)	27(1.06)	30(1.18)
ANSI Class 300	155.4(6.12)	114.3(4.50)	86(3.38)	44(1.73)	20.6(0.81)	1.6(0.06)	4	22.4(0.88)	27(1.06)	30(1.18)
ANSI Class 600	155.4(6.12)	114.3(4.50)	86(3.38)	44(1.73)	28.8(1.13)	6.4(0.25)	4	22.4(0.88)	27(1.06)	30(1.18)
JPI Class 150	127(5.00)	98.6(3.88)	86(3.38)	44(1.73)	17.6(0.69)	1.6(0.06)	4	16(0.63)	27(1.06)	30(1.18)
JPI Class 300	155(6.10)	114.3(4.50)	86(3.38)	44(1.73)	20.6(0.81)	1.6(0.06)	4	22(0.87)	27(1.06)	30(1.18)
JPI Class 600	155(6.10)	114.3(4.50)	86(3.38)	44(1.73)	28.9(1.14)	6.4(0.25)	4	22(0.87)	27(1.06)	30(1.18)