User's Manual

Model MLX Loop Powered Process Indicator

IM 60A02S01-01E-A



Contents

Loop Powered Process Indicator	1
Contents	2
1. Introduction	3
1.1 Safe Use of This Product	4
1.2 Warranty	5
1.3 ATEX Documentation	6
2. Handling Cautions	8
2.1 Model and Specifications Check	9
2.2 Unpacking	9
2.3 Storage	9
2.4 Selecting the Installation Location	9
2.5 Insulation Resistance and Dielectric Strength Test	10
2.6 Installation of an Explosion-Protected Instrument	11
2.6.1 Factory Mutual (FM) Certification	11
2.6.2 ATEX Certification	16
2.6.3 Canadian Standards Association (CSA) Certification	22
2.6.4 IECEx Certification	25
2.7 EMC Conformity Standards	29
2.8 Low Voltage Directive	29
3. Installation	30
3.1 Mounting Examples	31
4. Wiring	32
4.1 Wiring Precautions	32
4.2 Selecting the Wiring Materials	32
4.3 Wiring	33
4.3.1 Loop Configuration	33
5. Operation	35
5.1 Overview	35
5.2 Setting Engineering Units	41
6. Maintenance	43
6.1 Overview	43
6.2 Calibration Instruments Selection	43
6.3 Calibration	43
6.4 Rotating Display Direction	44
6.5 Cleaning	44
7. General Specifications	45
7.1 Standard Specifications	45
7.2 Model and Suffix Codes	46
7.5 Dimensions	50
Revision Record	51

1. Introduction

Thank you for purchasing the Model MLX Loop Powered Process Indicator. Your Model MLX Process Indicator was precisely calibrated at the factory before shipment. To ensure both safety and efficiency, please read this manual carefully before you operate the instrument.

The Model MLX field mounted indicator receives DC current signals from electronic transmitters and indicates process measurement values. This instruction manual gives instructions on handling, mounting, and wiring of the indicator.

■ Regarding This Manual

- This manual should be provided to the end user.
- The contents of this manual are subject to change without prior notice.
- All rights reserved. No part of this manual may be reproduced in any form without Yokogawa's written permission.
- Yokogawa makes no warranty of any kind with regard to this manual, including, but not limited to, implied warranty of merchantability and fitness for a particular purpose.
- If any question arises or errors are found, or if any information is missing from this manual, please inform the nearest Yokogawa sales office.
- The specifications covered by this manual are limited to those for the standard type under the specified model number break-down and do not cover custom-made instruments.
- Please note that changes in the specifications, construction, or component parts of the instrument may not immediately be reflected in this manual at the time of change, provided that postponement of revisions will not cause difficulty to the user from a functional or performance standpoint.
- Yokogawa assumes no responsibilities for this product except as stated in the warranty.
- If the customer or any third party is harmed by the use of this product, Yokogawa assumes no responsibility for any such harm owing to any defects in the product which were not predictable, or for any indirect damages.
- The following safety symbols are used in this manual:



WARNING

Indicates a potentially hazardous situation which, if not avoided, could result in death or serious injury.



CAUTION

Indicates a potentially hazardous situation which, if not avoided, may result in minor or moderate injury. It may also be used to alert against unsafe practices.



IMPORTANT

Indicates that operating the hardware or software in this manner may damage it or lead to system failure.



NOTE

Draws attention to information essential for understanding the operation and features.



Direct current

1.1 Safe Use of This Product

For the safety of the operator and to protect the instrument and the system, please be sure to follow this manual's safety instructions when handling this instrument. If these instructions are not heeded, the protection provided by this instrument may be impaired. In this case, Yokogawa cannot guarantee that the instrument can be safely operated. Please pay special attention to the following points:

(a) Installation

- This instrument may only be installed by an engineer or technician who has an expert knowledge of this device. Operators are not allowed to carry out installation unless they meet this condition.
- All installation shall comply with local installation requirements and the local electrical code.

(b) Wiring

- The instrument must be installed by an engineer or technician who has an expert knowledge of this instrument. Operators are not permitted to carry out wiring unless they meet this condition.
- Before connecting the power cables, please confirm that there is no current flowing through the cables and that the power supply to the instrument is switched off.

(c) Operation

- Do not open the covers when an explosive atmosphere is present.

(d) Maintenance

- Please carry out only the maintenance procedures described in this manual. If you require further assistance, please contact the nearest Yokogawa office.
- Care should be taken to prevent the build up of dust or other materials on the display glass and the name plate.

(e) Modification

- Yokogawa will not be liable for malfunctions or damage resulting from any modification made to this instrument by the customer.

1.2 Warranty

- The warranty shall cover the period noted on the quotation presented to the purchaser at the time of purchase. Problems occurring during the warranty period shall basically be repaired free of charge.
- If any problems are experienced with this instrument, the customer should contact the Yokogawa representative from which this instrument was purchased or the nearest Yokogawa office.
- If a problem arises with this instrument, please inform us of the nature of the problem and the circumstances under which it developed, including the model specification and serial number. Any diagrams, data and other information you can include in your communication will also be helpful.
- The party responsible for the cost of fixing the problem shall be determined by Yokogawa following an investigation conducted by Yokogawa.
- The purchaser shall bear the responsibility for repair costs, even during the warranty period, if the malfunction is due to:
 - Improper and/or inadequate maintenance by the purchaser.
 - Malfunction or damage due to a failure to handle, use, or store the instrument in accordance with the design specifications.
 - Use of the product in question in a location not conforming to the standards specified by Yokogawa, or due to improper maintenance of the installation location.
 - Failure or damage due to modification or repair by any party except Yokogawa or an approved representative of Yokogawa.
 - Malfunction or damage from improper relocation of the product in question after delivery.
 - Reason of force majeure such as fires, earthquakes, storms/floods, thunder/lightening, or other natural disasters, or disturbances, riots, warfare, or radioactive contamination.

1.3 ATEX Documentation

This is only applicable to the countries in the European Union.

GB

All instruction manuals for ATEX Ex related products are available in English, German and French. Should you require Ex related instructions in your local language, you are to contact your nearest Yokogawa office or representative.

DK

Alle brugervejledninger for produkter relateret til ATEX Ex er tilgængelige på engelsk, tysk og fransk. Skulle De ønske yderligere oplysninger om håndtering af Ex produkter på eget sprog, kan De rette henvendelse herom til den nærmeste Yokogawa afdeling eller forhandler.

I

Tutti i manuali operativi di prodotti ATEX contrassegnati con Ex sono disponibili in inglese, tedesco e francese. Se si desidera ricevere i manuali operativi di prodotti Ex in lingua locale, mettersi in contatto con l'ufficio Yokogawa più vicino o con un rappresentante.

E

Todos los manuales de instrucciones para los productos antiexplosivos de ATEX están disponibles en inglés, alemán y francés. Si desea solicitar las instrucciones de estos artículos antiexplosivos en su idioma local, deberá ponerse en contacto con la oficina o el representante de Yokogawa más cercano.

NL

Alle handleidingen voor producten die te maken hebben met ATEX explosiebeveiliging (Ex) zijn verkrijgbaar in het Engels, Duits en Frans. Neem, indien u aanwijzingen op het gebied van explosiebeveiliging nodig hebt in uw eigen taal, contact op met de dichtstbijzijnde vestiging van Yokogawa of met een vertegenwoordiger.

SF

Kaikkien ATEX Ex -tyyppisten tuotteiden käyttöohjeet ovat saatavilla englannin-, saksan- ja ranskankielisinä. Mikäli tarvitsette Ex -tyyppisten tuotteiden ohjeita omalla paikallisella kielellänne, ottakaa yhteyttä lähimpään Yokogawa-toimistoon tai -edustajaan.

P

Todos os manuais de instruções referentes aos produtos Ex da ATEX estão disponíveis em Inglês, Alemão e Francês. Se necessitar de instruções na sua lingual relacionadas com produtos Ex, deverá entrar em contacto com a delegação mais próxima ou com um representante da Yokogawa.

F

Tous les manuels d'instruction des produits ATEX Ex sont disponibles en langue anglaise, allemande et française. Si vous nécessitez des instructions relatives aux produits Ex dans votre langue, veuillez bien contacter votre représentant Yokogawa le plus proche.

D

Alle Betriebsanleitungen für ATEX Ex bezogene Produkte stehen in den Sprachen Englisch, Deutsch und Französisch zur Verfügung. Sollten Sie die Betriebsanleitungen für Ex-Produkte in Ihrer Landessprache benötigen, setzen Sie sich bitte mit Ihrem örtlichen Yokogawa-Vertreter in Verbindung.

S

Alla instruktionsböcker för ATEX Ex (explosionssäkra) produkter är tillgängliga på engelska, tyska och franska. Om Ni behöver instruktioner för dessa explosionssäkra produkter på annat språk, skall Ni kontakta närmaste Yokogawakontor eller representant.

2. Handling Cautions

This chapter provides important information on how to handle the MLX Loop Powered Process Indicator. Read this carefully before using the indicator.

The MLX indicator is thoroughly tested at the factory before shipment. When taking delivery of an instrument, visually check it to make sure that no damage occurred during shipment.

Also check that the indicator mounting hardware shown in figure 2.1 is included. After checking the indicator, carefully repack it in its box and keep it there until you are ready to install it.

Vertical Pipe Mounting

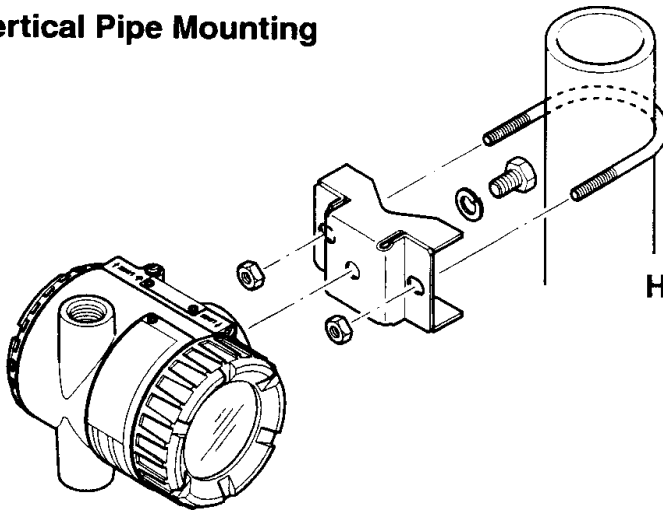

Horizontal Pipe Mounting

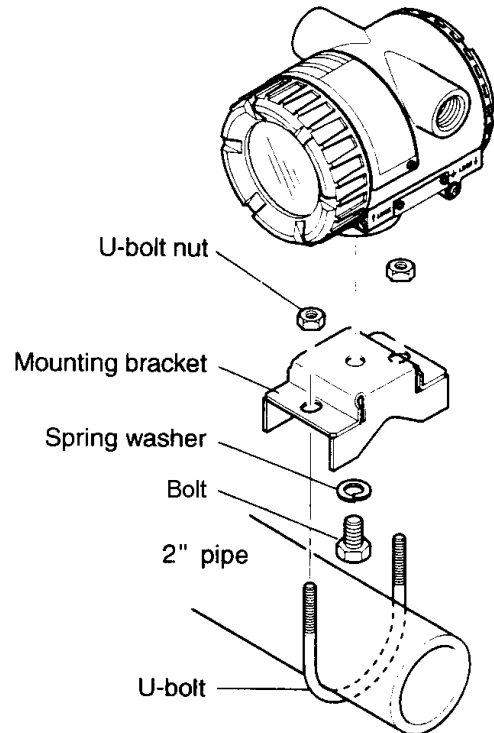

Wall Mounting

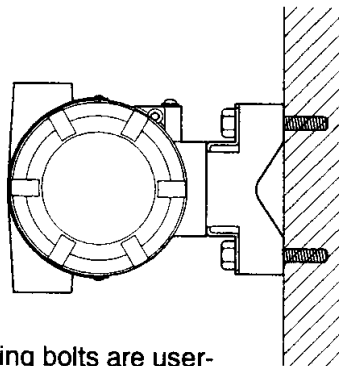

Note: Wall mounting bolts are user-supplied.

Figure 2.1 MLX Mounting Hardware

2.1 Model and Specifications Check

The model name and specifications are written on the name plate attached to the case.

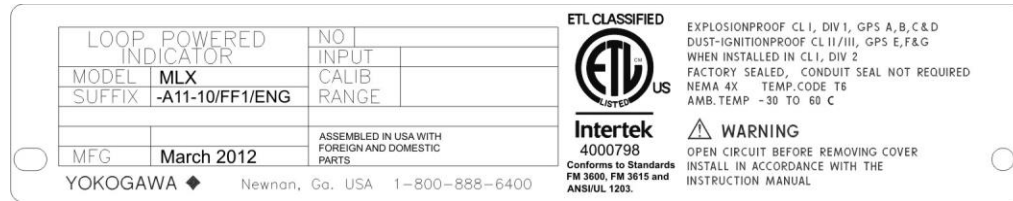

MODEL: Specified model code.
 SUFFIX: Specified suffix code.
 MFG: Year of manufacture.
 NO.: Serial number.
 INPUT: Input signal (4-20mA DC).
 CALIB RANGE: Specified calibration range.

Figure 2.2 MLX Name Plate

2.2 Unpacking

Keep the indicator in its original packaging to prevent it from being damaged during shipment. Do not unpack the indicator until it reaches the installation site.

2.3 Storage

The following precautions must be observed when storing the instrument, especially for a long period.

- (a) Select a storage area which meets the following conditions:
 - It is not exposed to rain or subject to water seepage/leaks.
 - Vibration and shock are kept to a minimum.
 - It has an ambient temperature and relative humidity within the following ranges.
 - Ambient temperature: -40 to 80°C (approval codes may affect limits)
 - Relative humidity: 0% to 100% R.H.
 - Preferred temperature and humidity: approx. 25°C and 65% R.H.
- (b) When storing the indicator, repack it carefully in the packaging that it was originally shipped with.

2.4 Selecting the Installation Location

- (1) The MLX is designed to withstand severe environmental conditions. However, to ensure that it will provide years of stable and accurate performance, take the following precautions when selecting the installation location.
- (2) Ambient Temperature
- (3) Avoid locations subject to wide temperature variations or a significant temperature gradient. If the location is exposed to radiant heat from plant equipment, provide adequate thermal insulation and/or ventilation.

- (4) Ambient Atmosphere
- (5) Do not install the indicator in a corrosive atmosphere. If this cannot be avoided, there must be adequate ventilation as well as measures to prevent the leaking of rain water and the presence of standing water in the conduits.
- (6) Shock and Vibration
- (7) Although the MLX is designed to be relatively resistant to shock and vibration, an installation site should be selected where this is kept to a minimum.

2.5 Insulation Resistance and Dielectric Strength Test

Since the MLX has undergone insulation resistance and dielectric strength tests at the factory before shipment, normally these tests are not required. If the need arises to conduct these tests, heed the following:

- (1) Do not perform such tests more frequently than is absolutely necessary. Even test voltages that do not cause visible damage to the insulation may degrade the insulation and reduce safety margins.
- (2) Never apply a voltage exceeding 500 V DC (100 V DC with an internal lightning protector) for the insulation resistance test, nor a voltage exceeding 500 V AC (100 V AC with an internal lightning protector) for the dielectric strength test.
- (3) Before conducting these tests, disconnect all signal lines from the transmitter terminals. The procedure for conducting these tests is as follows:
 - **Insulation Resistance Test**
 - (1) Short-circuit the + and – SUPPLY terminals in the terminal box.
 - (2) Turn OFF the insulation tester. Then connect the insulation tester plus (+) lead wire to the shorted SUPPLY terminals and the minus (–) lead wire to the grounding terminal.
 - (3) Turn ON the insulation tester power and measure the insulation resistance. The voltage should be applied as briefly as possible to verify that the insulation resistance is at least 20 M Ω .
 - (4) After completing the test and being very careful not to touch exposed conductors disconnect the insulation tester and connect a 100 k Ω resistor between the grounding terminal and the short-circuiting SUPPLY terminals. Leave this resistor connected at least one second to discharge any static potential. Do not touch the terminals while it is discharging.
 - **Dielectric Strength Test**
 - (1) Short-circuit the + and – SUPPLY terminals in the terminal box.
 - (2) Turn OFF the dielectric strength tester. Then connect the tester between the shorted SUPPLY terminals and the grounding terminal. Be sure to connect the grounding lead of the dielectric strength tester to the ground terminal.
 - (3) Set the current limit on the dielectric strength tester to 10mA, then turn ON the power and gradually increase the test voltage from '0' to the specified voltage.
 - (4) When the specified voltage is reached, hold it for one minute.
 - (5) After completing this test, slowly decrease the voltage to avoid any voltage surges.

2.6 Installation of an Explosion-Protected Instrument

WARNING

If a customer makes a repair or modification and the instrument is not restored to its original condition, its safety may be compromised and the instrument may be hazardous to operate. Please contact Yokogawa before making any repair or modification to an instrument.

CAUTION

This instrument has been tested and certified as being Explosionproof. Please note that severe restrictions apply to this instrument's construction, installation, external wiring, maintenance and repair. A failure to abide by these restrictions could make the instrument a hazard to operate.

WARNING

Maintaining the safety of Explosionproof equipment requires great care during mounting, wiring, and piping. Safety requirements also place restrictions on maintenance and repair. Please read the following sections very carefully.

2.6.1 Factory Mutual (FM) Certification

1) Technical Data

a. FM Explosionproof/Dust-Ignition-Proof Type

Caution for FM Explosionproof/Dust-Ignition-Proof type.

Note 1. Model MLX Loop Process Indicators with optional code /FF1 applicable for use in potentially hazardous locations:

- Certificate No. 4000798
- Conforms to: FM 3600, FM 3615, FM 3616, UL 1203
- Explosionproof/Dust-Ignition-Proof for Class I, II, II; Division 1 & 2, Groups A – G; Class I, Zone 1, Group IIC T4
- Enclosure rating: NEMA 4X.
- Temperature Class: T4
- Ambient Temperature: –40°C to 80°C

Note 2. Wiring

- For an ambient temperature $\geq 70^{\circ}\text{C}$, heat resistant cables shall be used with a rating of at least 20°C above the ambient temperature.

- In hazardous location, wiring shall be in conduit.
WARNING: A SEAL SHALL BE INSTALLED WITHIN 50 cm OF THE ENCLOSURE.
- When installed in Division 2, “FACTORY SEALED, CONDUIT SEAL NOT REQUIRED”.
- All wiring shall comply with National Electrical Code ANSI/NEPA70 and Local Electrical Codes.

Note 3. Installation

- Installation should be in accordance with ANSI/ISA RP12.6 “Installation of Intrinsically Safe Systems for Hazardous (Classified) Locations” and the National Electric Code (ANSI/NFPA 70).
- Strictly observe the “WARNING” on the attached nameplate.
WARNING: OPEN CIRCUIT BEFORE REMOVING COVER. INSTALL IN ACCORDANCE WITH THE INSTRUCTION MANUAL.

Note 4. Maintenance and Repair

- The instrument modification or parts replacement by other than authorized representative of Yokogawa Corporation of America is prohibited and will void Factory Mutual Explosionproof Approval.
-

Note 5. Special Conditions for Safe Use

- In the case where the enclosure of the MLX is made of aluminum, if it is mounted in an area requiring Class 1 Division 1 equipment, it must be installed such, that, in the event of rare incidents or rare malfunction, ignition sources due to impact and friction sparks are excluded.



WARNING

ELECTROSTATIC CHARGE HAZARD MAY CAUSE AN EXPLOSION HAZARDS DUE TO THE PAINT THICKNESS OF THE EQUIPMENT NOT MEETING THE REQUIREMENTS FOR AVOIDING ELECTROSTATIC DISCHARGE ON GROUP II AND GROUP III ELECTRICAL EQUIPMENT. AVOID ANY ACTIONS THAT CAUSE AN ELECTROSTATIC DISCHARGE OF THE ENCLOSURE, SUCH AS RUBBING WITH A DRY CLOTH ON ANY SURFACE OF THE PRODUCT. PRECAUTIONS SHALL BE TAKEN TO MINIMIZE THE RISK FROM ELECTROSTATIC DISCHARGE OF PAINTED OR COATED PARTS OF EQUIPMENT.

b. FM Intrinsically Safe/FM Explosionproof/Dust-Ignition-Proof Type

Caution for FM Intrinsically Safe/FM Explosionproof/Dust-Ignition-Proof type.

Note 1. Model MLX Loop Process Indicators with optional code /FU1 applicable for use in potentially hazardous locations:

- Certificate No. 4000798
- Conforms to: FM 3600, FM 3610, FMRC 3611, FM 3615, FM 3616, UL 913, UL 1203, UL 60079-0, UL 60079-11
- Explosionproof/Dust-Ignition-Proof for:
 - Class I, II, III; Groups A -G; Divisions 1 & 2.
 - Class I, Zone 1, Group IIC T4.
 - Tamb. -40°C to 80°C
- Intrinsically Safe for:
 - Class I, Division 1, II, III; Groups A -G; Divisions 1 & 2.
 - Zone 20, Class I, Zone 0
 - AEx ia IIC T4
 - Tamb. -40°C to 80°C
- Non-Incendive for:
 - Class I, II, III; Groups A - D, F, G; Divisions 2.
 - Class I, Zone 2, Group IIC T4.
 - Tamb. -40°C to 80°C
- Enclosure rating: NEMA 4X.
- Temperature Class: T4
- Ambient Temperature: -40°C to 80°C

Note 2. Entity Parameters

- Intrinsically Safe Apparatus Parameters
 [Groups A - G]
 $U_i = 28 \text{ V}$ $C_i = 0 \text{ pF}$
 $I_i = 115 \text{ mA}$ $L_i = 0 \text{ } \mu\text{H}$
 $P_i = 0.65 \text{ W}$
- Non-Incendive Apparatus Parameters
 [Groups A – D, F, G]
 $U_i = 30 \text{ V}$
 $I_i = 150 \text{ mA}$
 $P_i = 0.85 \text{ W}$

Note 3. Wiring

- All wiring shall comply with National Electrical Code ANSI/NEPA70 and Local Electrical Codes.
- For an ambient temperature $\geq 70^\circ\text{C}$, heat resistant cables shall be used with a rating of at least 20°C above the ambient temperature.
- In hazardous location, wiring shall be in conduit.

WARNING: A SEAL SHALL BE INSTALLED WITHIN 50 cm OF THE ENCLOSURE.

When installed in Division 2, "FACTORY SEALED, CONDUIT SEAL NOT REQUIRED".

Note 4. Installation

- Installation should be in accordance with ANSI/ISA RP12.6 "Installation of Intrinsically Safe Systems for Hazardous (Classified) Locations" and the National Electric Code (ANSI/NFPA 70).

- The safety barrier must be FM approved.
- Strictly observe the “WARNING” on the attached nameplate.

WARNING: SUBSTITUTION OF COMPONENTS MAY IMPAIR INTRINSIC SAFETY.

WARNING: DO NOT OPEN COVERS WHEN AN EXPLOSIVE ATMOSPHERE MAY BE PRESENT. INSTALL IN ACCORDANCE WITH THE INSTRUCTION MANUAL.

Note 5. Maintenance and Repair

- The instrument modification or parts replacement by other than authorized representative of Yokogawa Electric Corporation is prohibited and will void Factory Mutual Explosionproof Approval.

Note 6. Special Conditions for Safe Use

- In the case where the enclosure of the MLX is made of aluminum, it must be installed such, that, even in the event of rare incidents, ignition sources due to impact and friction sparks are excluded.



WARNING

ELECTROSTATIC CHARGE HAZARD MAY CAUSE AN EXPLOSION HAZARDS DUE TO THE PAINT THICKNESS OF THE EQUIPMENT NOT MEETING THE REQUIREMENTS FOR AVOIDING ELECTROSTATIC DISCHARGE ON GROUP II AND GROUP III ELECTRICAL EQUIPMENT. AVOID ANY ACTIONS THAT CAUSE AN ELECTROSTATIC DISCHARGE OF THE ENCLOSURE, SUCH AS RUBBING WITH A DRY CLOTH ON ANY SURFACE OF THE PRODUCT. PRECAUTIONS SHALL BE TAKEN TO MINIMIZE THE RISK FROM ELECTROSTATIC DISCHARGE OF PAINTED OR COATED PARTS OF EQUIPMENT.

[Intrinsically safe]

Group IIC, Zone 0
 Class I, II, III, Division 1 & 2
 Groups A - G

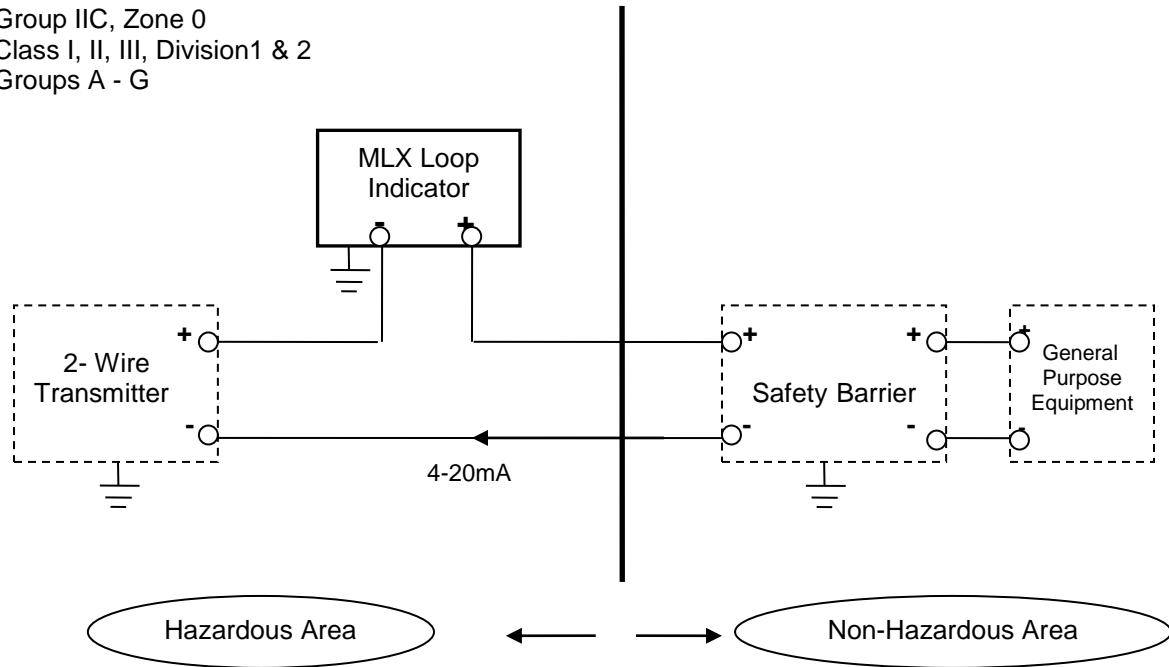

[Non-incendive]

Group IIC, Zone 2 T4
 Class I, II, III, Division 2
 Groups A - D, F, G

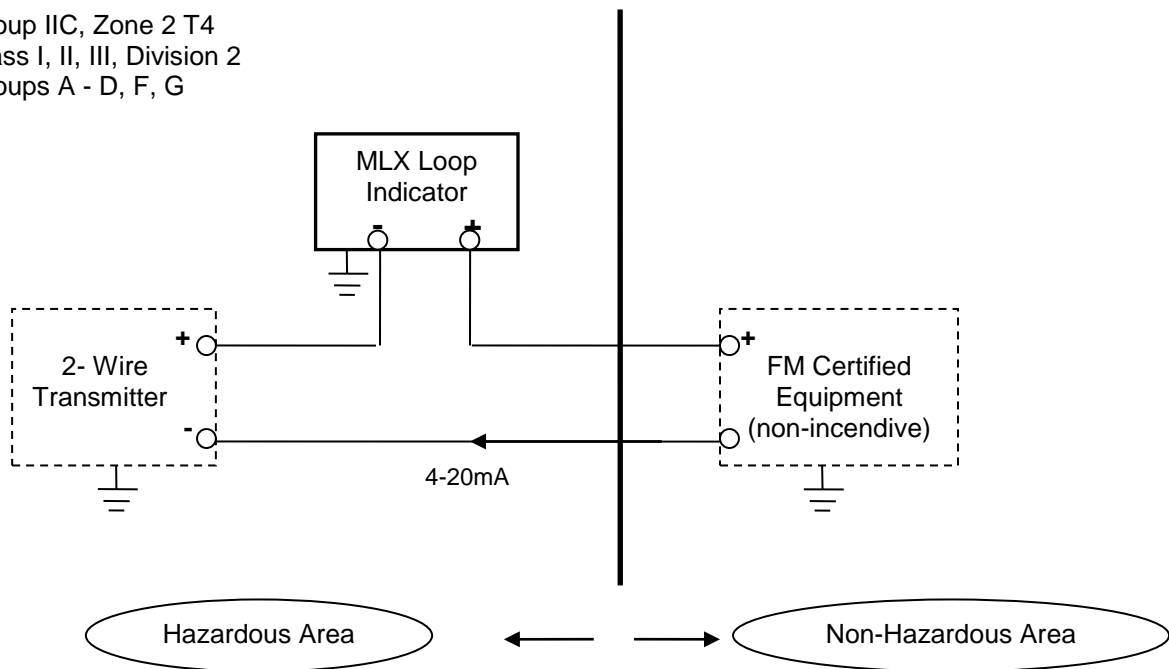

2.6.2 ATEX Certification

1) Technical Data

a. ATEX Intrinsically Safe/ATEX Flameproof/ATEX Non-Incendive Type

Caution for ATEX Intrinsically Safe/ATEX Flameproof/ ATEX Non-Incendive Type.

Note 1. Model MLX Loop Process Indicators with optional code /KU21 applicable for use in potentially hazardous locations:

- Certificate No. ITS13ATEX27856X
- Certificate No. ITS13ATEX17857X
- Certificate No. ITS13ATEX47858X
- Applicable Standard: EN 60079-0:2009, EN 60079-11:2007, EN 60079-26:2007
- Type of Protection and Marking code:
 - II 1G Ex ia IIC T4 Ga
 - II 2G Ex d IIC T4 Gb
 - II 2D Ex tb IIC T135 Db
 - II 3G Ex nA IIC T4 Gc
- Tamb. -40°C to 80°C
- Enclosure rating: IP66 and IP67

Note 2. Electrical Data

- In the case where the type of explosion protection is intrinsically safe, Ex ia IIC T4 Ga, only connect to a certified intrinsically safe circuit with the following maximum values:

$$U_i = 28 \text{ V}$$

$$I_i = 115 \text{ mA}$$

$$P_i = 0.65 \text{ W}$$

Effective internal capacitance; $C_i = 0$

Effective internal inductance; $L_i = 0$

- In the case where the type of explosion protection is Non-Incendive, Ex nA IIC T4 Gc, only connect to a certified intrinsically safe circuit with the following maximum values:

$$U_i = 30 \text{ V}$$

$$I_i = 150 \text{ mA}$$

$$P_i = 0.85 \text{ W}$$

Note 3. Wiring

- For an ambient temperature $\geq 70^{\circ}\text{C}$, heat resistant cables shall be used with a rating of at least 20°C above the ambient temperature.
- All wiring shall comply with local installation requirements. (Refer to the installation diagram)

Note 4. Installation

- Observe WARNING on nameplate. (Refer to the installation diagram)
WARNING: AFTER DE-ENERGIZING, DELAY 5 MIN BEFORE OPENING COVER.
- When used in a potentially explosive atmosphere, requiring the use of apparatus of equipment category 1D or 2D, certified cable entry devices shall be used that are suitable for the application and correctly installed.

Note 5. Maintenance and Repair

- The instrument modification or parts replacement by other than authorized representative of Yokogawa Electric Corporation is prohibited and will void Intrinsically Safe Certification.

Note 6. Special Conditions for Safe Use

- In the case where the enclosure of the MLX is made of aluminum, if it is mounted in an area requiring Category 1 G equipment (EPL Ga), it must be installed such, that, in the event of rare incidents or rare malfunction, ignition sources due to impact and friction sparks are excluded.



WARNING

To satisfy IP66 or IP67, apply waterproof glands to the electrical connection port.



WARNING

ELECTROSTATIC CHARGE HAZARD MAY CAUSE AN EXPLOSION HAZARDS DUE TO THE PAINT THICKNESS OF THE EQUIPMENT NOT MEETING THE REQUIREMENTS FOR AVOIDING ELECTROSTATIC DISCHARGE ON GROUP II AND GROUP III ELECTRICAL EQUIPMENT. AVOID ANY ACTIONS THAT CAUSE AN ELECTROSTATIC DISCHARGE OF THE ENCLOSURE, SUCH AS RUBBING WITH A DRY CLOTH ON ANY SURFACE OF THE PRODUCT. PRECAUTIONS SHALL BE TAKEN TO MINIMIZE THE RISK FROM ELECTROSTATIC DISCHARGE OF PAINTED OR COATED PARTS OF EQUIPMENT.

[Intrinsically safe]

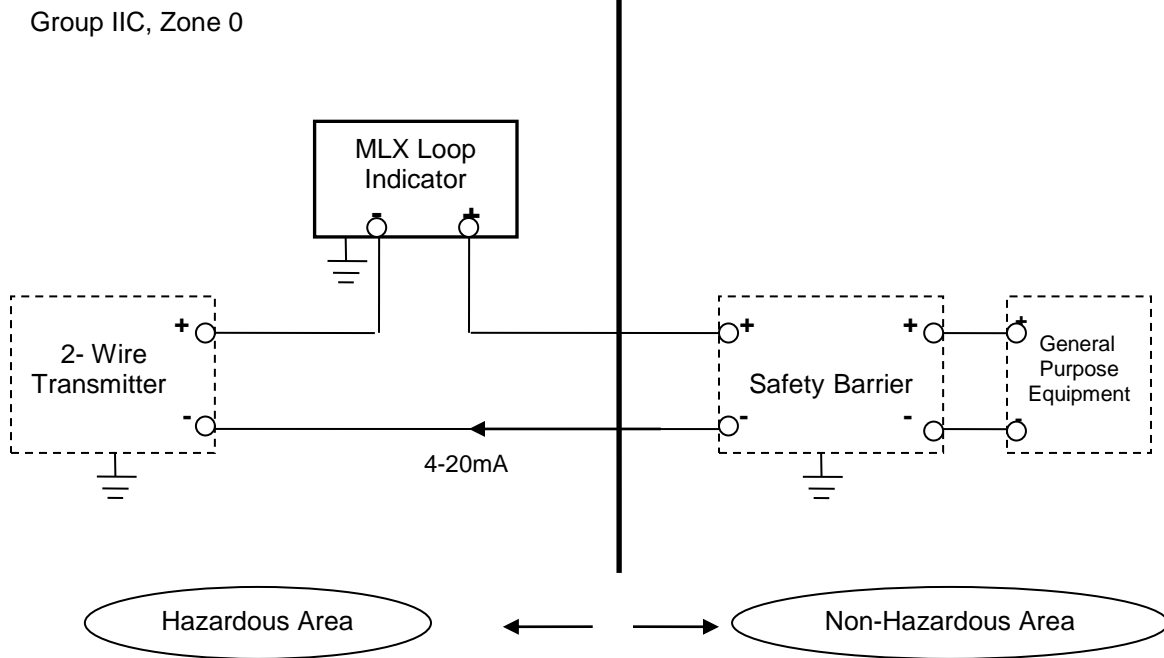

[Non-incendive]

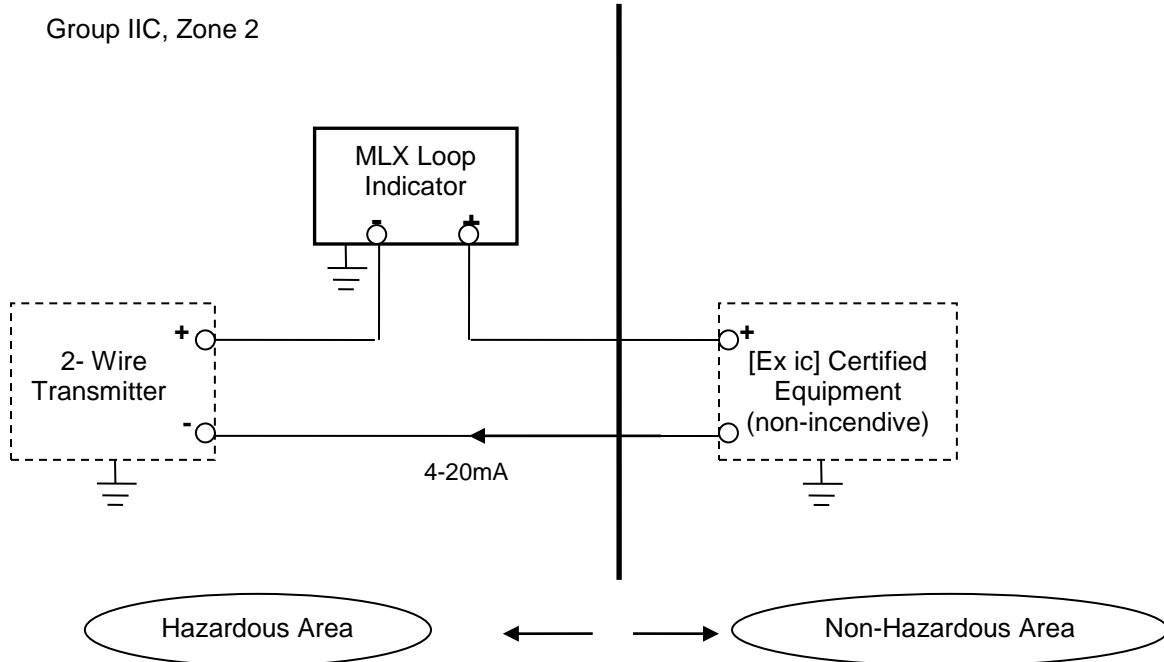

Note 4. Maintenance and Repair

- The instrument modification or parts replacement by other than authorized representative of Yokogawa Corporation of America is prohibited and will void Intrinsically Safe Certification.

Note 5. Special Conditions for Safe Use

- In the case where the enclosure of the MLX is made of aluminum, if it is mounted in an area requiring Category 1 G equipment (EPL Ga), it must be installed such, that, in the event of rare incidents or rare malfunction, ignition sources due to impact and friction sparks are excluded.

2) Nameplate

- Nameplate for FM Explosionproof/Dust Ignition-proof type (Option /FF1)

LOOP POWERED INDICATOR		NO	M1275BS
MODEL	MLX	INPUT	4-20mA DC ≡
SUFFIX		CALIB RANGE	
MFG		ASSEMBLED IN USA WITH FOREIGN AND DOMESTIC PARTS	
YOKOGAWA ◆ Newnan, Ga. USA 1-800-888-6400			



ETL CLASSIFIED
Intertek
4000798

Conforms to: FM 3600, FM 3615, UL 1203.

Explosionproof/Dust-Ignition-Proof for Class I, II, III; Groups A - G; Divisions 1 & 2
Class I, Zone 1, Group IIC T4
Temp. Class: T4
Tamb.: -40°C to 80°C
Enclosure: NEMA 4X

⚠ WARNING
WARNING: DO NOT OPEN COVERS WHEN AN EXPLOSIVE ATMOSPHERE MAY BE PRESENT. INSTALL IN ACCORDANCE WITH THE INSTRUCTION MANUAL.

- Nameplate for FM Intrinsically Safe/Explosionproof/Dust-Ignition-proof/Non-Incendive type (Option /FU1)

LOOP POWERED INDICATOR		NO	M1275DT
MODEL	MLX	INPUT	4-20mA DC ≡
SUFFIX		CALIB RANGE	
MFG		ASSEMBLED IN USA WITH FOREIGN AND DOMESTIC PARTS	
YOKOGAWA ◆ Newnan, Ga. USA 1-800-888-6400			



ETL CLASSIFIED
Intertek
4000798

Conforms to: FM 3600, FM 3610, FMRC 3611, FM 3615, FM 3616, UL 913, UL 1203, UL 60079-0, UL 60079-11.

Intrinsically Safe for Class I, II, III; Groups A - G; Divisions 1 & 2; Zone 20, Class I, Zone 0, AEx ia IIC T4 Ga -40°C < Ta < +80°C
Ui = 28V, Ii = 115mA, Pi = 0.65W, Ci = 0uF, Li = 0mH
Explosionproof/Dust-Ignition-Proof for Class I, II, III; Groups A - G; Divisions 1 & 2
Class I, Zone 1, Group IIC, T4 Tamb. -40°C to 80°C
Non-Incendive for Class I, II, III; Groups A - D, F, G; Division 2
Class I, Zone 2, Group IIC T4 Tamb. -40°C to 80°C
Enclosure: NEMA 4X

⚠ WARNING
WARNING: SUBSTITUTION OF COMPONENTS MAY IMPAIR INTRINSIC SAFETY.
WARNING: DO NOT OPEN COVERS WHEN AN EXPLOSIVE ATMOSPHERE MAY BE PRESENT. INSTALL IN ACCORDANCE WITH THE INSTRUCTION MANUAL.

- Nameplate for ATEX Intrinsically Safe/Flameproof/Dustproof/Non-Incendive type (Option /KU21)

LOOP POWERED INDICATOR		NO	M1275DU
MODEL	MLX	INPUT	4-20mA DC ≡
SUFFIX		CALIB RANGE	
MFG		ASSEMBLED IN USA WITH FOREIGN AND DOMESTIC PARTS	
YOKOGAWA ◆ Newnan, Ga. USA 1-800-888-6400			



CE
0344

Cert. No: ITS13ATEX27856X
Cert. No: ITS13ATEX17857
Cert. No: ITS13ATEX47858II 1G Ex ia IIC T4 Ga
Ui = 28V, Ii = 115mA, Pi = 0.65W, Ci = 0uF, Li = 0mH
II 2G Ex d IIC T4 Gb
II 2D Ex tb IIC T135 Db
II 3G Ex nA IIC T4 Gc
Tamb. -40°C to +80°C
Enclosure: IP66 and IP67

⚠ WARNING
AFTER DE-ENERGIZING, DELAY 5 MIN BEFORE OPENING COVER. WHEN THE AMBIENT TEMP. = 70°C, USE HEATRESISTING CABLE RATED = 90°C.
INSTALL IN ACCORDANCE WITH THE INSTRUCTION MANUAL.

- Nameplate for CSA Intrinsically Safe/Explosionproof/Dust-Ignition-proof/Non-Incendive type (Option /CU1)

LOOP POWERED INDICATOR		NO	M1275DV
		INPUT	4-20mA DC ≡
MODEL	MLX	CALIB	
SUFFIX		RANGE	
MFG		ASSEMBLED IN USA WITH FOREIGN AND DOMESTIC PARTS	

YOKOGAWA ◆ Newnan, Ga. USA 1-800-888-6400



ETL CLASSIFIED
Intertek
4000798

Certified to: CSA-C22.2 No. 25, CSA-C22.2 No. 30, CSA-C22.2 No. 157, CSA-C22.2 No. 213, CSA-C22.2 No. 60079-0, CAN/CSA E60079-11.

Intrinsically Safe (Securite Intrinsicque) for Class I, II, III; Groups A - G; Divisions 1 & 2; Zone 20, Class I, Zone 0, AEx ia IIC T4 Ga -40°C < Ta < +80°C U_i = 28V, I_i = 115mA, P_i = 0.65W, C_i = 0uF, L_i = 0mH
Explosionproof/Dust-Ignition-Proof for Class I, II, III; Groups A - G; Divisions 1 & 2
Class I, Zone 1, Group IIC, T4 Tamb. -40°C to 80°C
Nonincendive for Class I, II, III; Groups A - D, F, G; Division 2
Class I, Zone 2, Group IIC T4 Tamb. -40°C to 80°C
Enclosure: "Type 4X"
WARNING
WARNING: SUBSTITUTION OF COMPONENTS MAY IMPAIR INTRINSIC SAFETY
ADVERTISSEMENT: LA SUBSTITUTION DE COMPOSANTS PEUT COMPROMETTRE LA SECURITE INTRINSEQUE.
WARNING: DO NOT OPEN COVERS WHEN AN EXPLOSIVE ATMOSPHERE MAY BE PRESENT. INSTALL IN ACCORDANCE WITH THE INSTRUCTION MANUAL. ATTENTION: NE PAS OUVRIR SI des explosifs ATMOSPHERE peuvent être présents. INSTALLER EN SELON LE MODE D'EMPLOI.

- Nameplate for IEC Intrinsically Safe/Flameproof/Dustproof/Non-Incendive type (Option /SU2)

LOOP POWERED INDICATOR		NO	M1275DV
		INPUT	4-20mA DC ≡
MODEL	MLX	CALIB	
SUFFIX		RANGE	
MFG		ASSEMBLED IN USA WITH FOREIGN AND DOMESTIC PARTS	

YOKOGAWA ◆ Newnan, Ga. USA 1-800-888-6400

Cert. No: IECEx ETL 13.0028X
Cert. No: IECEx ETL 13.0029
Cert. No: IECEx ETL 13.0030
Ex ia IIC T4 Ga
U_i = 28V, I_i = 115mA, P_i = 0.65W, C_i = 0uF, L_i = 0mH
Ex d IIC T4 Gb
Ex tb IIC T135 Db
Ex nA IIC T4 Gc
Tamb. -40°C to +80°C
Enclosure: IP66 and IP67
WARNING
AFTER DE-ENERGIZING, DELAY 5 MIN BEFORE OPENING COVER. WHEN THE AMBIENT TEMP. = 70°C, USE HEATRESISTING CABLE RATED = 90°C.
INSTALL IN ACCORDANCE WITH THE INSTRUCTION MANUAL.

- Nameplate for Combined Approval type (Option /V1U – Combination of Options FU1, KU21, and CU1)

LOOP POWERED INDICATOR		NO	M1275DX
		INPUT	4-20mA DC ≡
MODEL	MLX	CALIB	
SUFFIX		RANGE	
MFG		ASSEMBLED IN USA WITH FOREIGN AND DOMESTIC PARTS	

YOKOGAWA ◆ Newnan, Ga. USA 1-800-888-6400



CE 0344 Ex
ETL CLASSIFIED
Intertek
4000798

Conforms to: FM 3600, FM 3610, FM 3611, FM 3615 FM 3616, UL 913, UL 1203, UL 60079-0,11.
Certified to: CSA-C22.2 No. 25, 30, 157, 213, 60079-0, 60079-11.

Intrinsically Safe (Securite Intrinsicque) for Class I, II; Groups A - G; Divisions 1 & 2 Zone 20 Class I, Zone 0, AEx ia IIC T4 Ga; II 1G Ex ia IIC T4 Ga -40°C < Ta < +80°C U_i = 28V, I_i = 115mA, P_i = 0.65W, C_i = 0uF, L_i = 0mH
Cert. No. IT513ATEX27856X, IECEx ETL 13.0028X
Explosionproof/Dust-Ignition-Proof for Class I, II; Groups A - G; Divisions 1 & 2
Class I, Zone 1, Group IIC; II 2G Ex d IIC T4 Gb; II 2D Ex db IIC T135 Db
Tamb. -40°C to 80°C Cert. No. IT513ATEX17897, IECEx ETL 130029
Nonincendive for Class I, II; Groups A - D, F, G; Division 2
Class I, Zone 2, Group IIC : II 3G Ex nA IIC T4 Gc Tamb. -40°C to 80°C
Cert. No. IT513ATEX47856, IECEx ETL 13.0030
Enclosure: NEMA 4X, IP66, IP67
WARNING
WARNING: SUBSTITUTION OF COMPONENTS MAY IMPAIR INTRINSIC SAFETY
ADVERTISSEMENT: LA SUBSTITUTION DE COMPOSANTS PEUT COMPROMETTRE LA SECURITE INTRINSEQUE
WARNING: DO NOT OPEN COVERS WHEN AN EXPLOSIVE ATMOSPHERE MAY BE PRESENT. INSTALL IN ACCORDANCE WITH THE INSTRUCTION MANUAL. ATTENTION: NE PAS OUVRIR SI des explosifs ATMOSPHERE peuvent être présents. INSTALLER EN SELON LE MODE D'EMPLOI.

3) Electrical connection

The type of electrical connection is stamped near the electrical connection port according to the following marking.

Thread Size	Marking
ISO M20 x 1.5 female	⚠ M
ANSI ½ x 14 NPT female	⚠ A
ISO G1/2 x 14 female	⚠ G

Notes : Certification Conditions for Safe Use

1. The Stopping Plugs or Blanking Elements shall not be used in conjunction with an adapter or reducer when installed in a flameproof enclosure.
2. Where Adapters and Reducers without sealing rings are installed in protection by enclosure (Ex t) equipment for use in explosive dust atmospheres, they shall only be fitted into enclosures offering a minimum of 5 full threads, in accordance with IEC 60079-31:2008 clause 5.1.1.
3. When no seal is fitted and the stopping plug is installed in an increased safety (Ex e) enclosure, the user shall ensure that a minimum degree of protection IP54 is maintained.
4. Where Stopping Plugs without sealing rings are installed in protection by enclosure (Ex t) equipment for use in explosive dust atmospheres, they may only be fitted into enclosures offering a minimum of 5 full threads, in accordance with IEC 60079-31:2008 clause 5.1.1.
5. Adapters and Reducers shall not to be used for the direct inter-connection of enclosures.
6. Only one adapter or reducer is to be used with any single cable entry on the associated equipment.

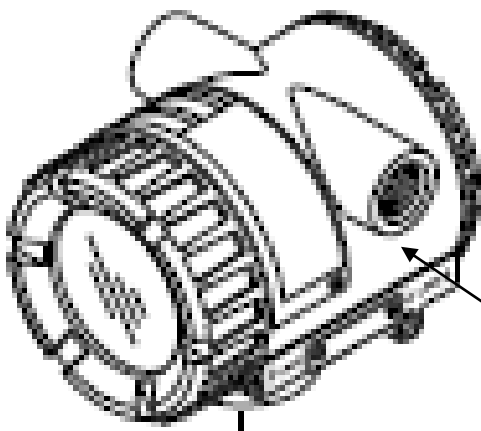

Location of the Thread Marking

2.6.3 Canadian Standards Association (CSA) Certification

1) Technical Data

a. CSA Intrinsically Safe/CSA Explosionproof/CSA Non-Incendive Type.

Caution for CSA Intrinsically Safe/CSA Explosionproof/CSA Non-Incendive type.

Note 1. Model MLX Loop Process Indicator with optional code /CU1 are applicable for use in potentially hazardous locations.

- Certificate No. 4000798
- Certified to: CSA C22.2 No.25, CSA C22.2 No.30, CSA C22.2 No.157, CSA C22.2 No.213, CSA C22.2 No.60079-0, CAN/CSA E60079-11
- Explosionproof/Dust-Ignition-Proof for:
 - Class I, II, III; Groups A - G; Divisions 1 & 2.
 - Class I, Zone 1, Group IIC T4.
 - Tamb. -40°C to 80°C
- Intrinsically Safe for:
 - Class I, Division 1, II, III; Groups A - G; Divisions 1 & 2.
 - Zone 20, Class I, Zone 0
 - AEx ia IIC T4
 - Tamb. -40°C to 80°C
- Non-Incendive for:
 - Class I, II, III; Groups A - D, F, G; Divisions 2.
 - Class I, Zone 2, Group IIC T4.
 - Tamb. -40°C to 80°C Enclosure: Type 4X
- Temp. Code: T4
- Amb. Temp.: -40°C to 80°C
- Enclosure: "Type 4X"

Note 2. Electrical Data

- Intrinsically safe ratings are as follows:
 - Maximum Input Voltage (V_{max}/U_i) = 28 V
 - Maximum Input Current (I_{max}/I_i) = 115 mA
 - Maximum Input Power (P_{max}/P_i) = 0.65 W
- Non-Incendive ratings are as follows:
 - Maximum Input Voltage (V_{max}/U_i) = 30 V
 - Maximum Input Current (I_{max}/I_i) = 150 mA
 - Maximum Input Power (P_{max}/P_i) = 0.85 W
- Installation Requirements
 - $U_o \leq U_i$, $I_o \leq I_i$, $P_o \leq P_i$,
 - $C_o \geq C_i + C_{\text{cable}}$, $L_o \geq L_i + L_{\text{cable}}$
 - $V_{oc} \leq V_{\text{max}}$, $I_{sc} \leq I_{\text{max}}$,
 - $C_a \geq C_i + C_{\text{cable}}$, $L_a \geq L_i + L_{\text{cable}}$
 - U_o , I_o , P_o , C_o , L_o , V_{oc} , I_{sc} , C_a and L_a are parameters of barrier.

Note 3. Wiring

All wiring shall comply with Canadian Electrical Code Part I and Local Electrical Codes.

- For an ambient temperature $\geq 70^{\circ}\text{C}$, heat resistant cables shall be used with a rating of at least 20°C above the ambient temperature.
- In hazardous location, wiring shall be in conduit.

WARNING: A SEAL SHALL BE INSTALLED WITHIN 50 cm OF THE ENCLOSURE.

When installed in Division 2, "FACTORY SEALED, CONDUIT SEAL NOT REQUIRED".

- In hazardous location, wiring shall be in conduit.

WARNING: A SEAL SHALL BE INSTALLED WITHIN 50 cm OF THE ENCLOSURE.

UN SCCELLEMENT DOIT ÊTRE INSTALLÉ À MOINS DE 50 cm DU BOÎTIER.

When installed in Division 2, "FACTORY SEALED, CONDUIT SEAL NOT REQUIRED".

Une fois installé dans la Division 2, «scellés en usine, CONDUIT SEAL PAS NÉCESSAIRE".

Note 4. Installation

- All wiring shall comply with local installation requirements.
- In any safety barrier used output current must be limited by a resistor 'R' such that $I_o=U_o/R$ or $I_{sc}=V_{oc}/R$.
- The safety barrier must be CSA certified.
- Input voltage of the safety barrier must be less than 250 Vrms/Vdc.
- Installation should be in accordance with Canadian Electrical Code Part I and Local Electrical Code.
- Dust-tight conduit seal must be used when installed in Class II and III environments.
- **WARNING: SUBSTITUTION OF COMPONENTS MAY IMPAIR INTRINSIC SAFETY.**
ADVERTISSEMENT: LA SUBSTITUTION DE COMPOSANTS PEUT COMPROMETTRE LA SECURITE INTRINSEQUE.
- **WARNING: DO NOT OPEN COVERS WHEN AN EXPLOSIVE ATMOSPHERE MAY BE PRESENT. INSTALL IN ACCORDANCE WITH THE INSTRUCTION MANUAL.**
ATTENTION: NE PAS OUVRIR Si des explosifs ATMOSPHERE peuvent être présents. INSTALLER EN SELON LE MODE D'EMPLOI.

Note 5. Maintenance and Repair

• The instrument modification or parts replacement by other than authorized representative of Yokogawa Electric Corporation is prohibited and will void Intrinsically Safe Certification.

Note 6. Special Conditions for Safe Use

• In the case where the enclosure of the MLX is made of aluminum, if it is mounted in an area requiring Class 1 Division 1 equipment, it must be installed such, that, in the

event of rare incidents or rare malfunction, ignition sources due to impact and friction sparks are excluded.



WARNING

ELECTROSTATIC CHARGE HAZARD MAY CAUSE AN EXPLOSION HAZARDS DUE TO THE PAINT THICKNESS OF THE EQUIPMENT NOT MEETING THE REQUIREMENTS FOR AVOIDING ELECTROSTATIC DISCHARGE ON GROUP II AND GROUP III ELECTRICAL EQUIPMENT. AVOID ANY ACTIONS THAT CAUSE AN ELECTROSTATIC DISCHARGE OF THE ENCLOSURE, SUCH AS RUBBING WITH A DRY CLOTH ON ANY SURFACE OF THE PRODUCT. PRECAUTIONS SHALL BE TAKEN TO MINIMIZE THE RISK FROM ELECTROSTATIC DISCHARGE OF PAINTED OR COATED PARTS OF EQUIPMENT.

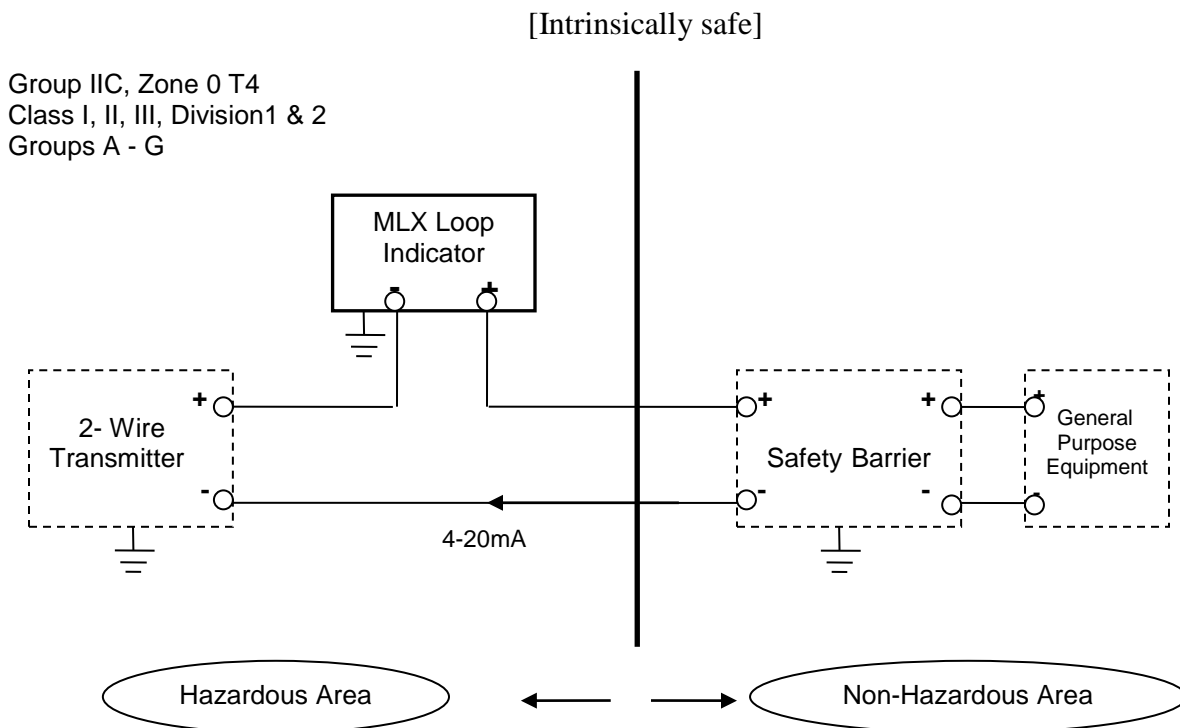

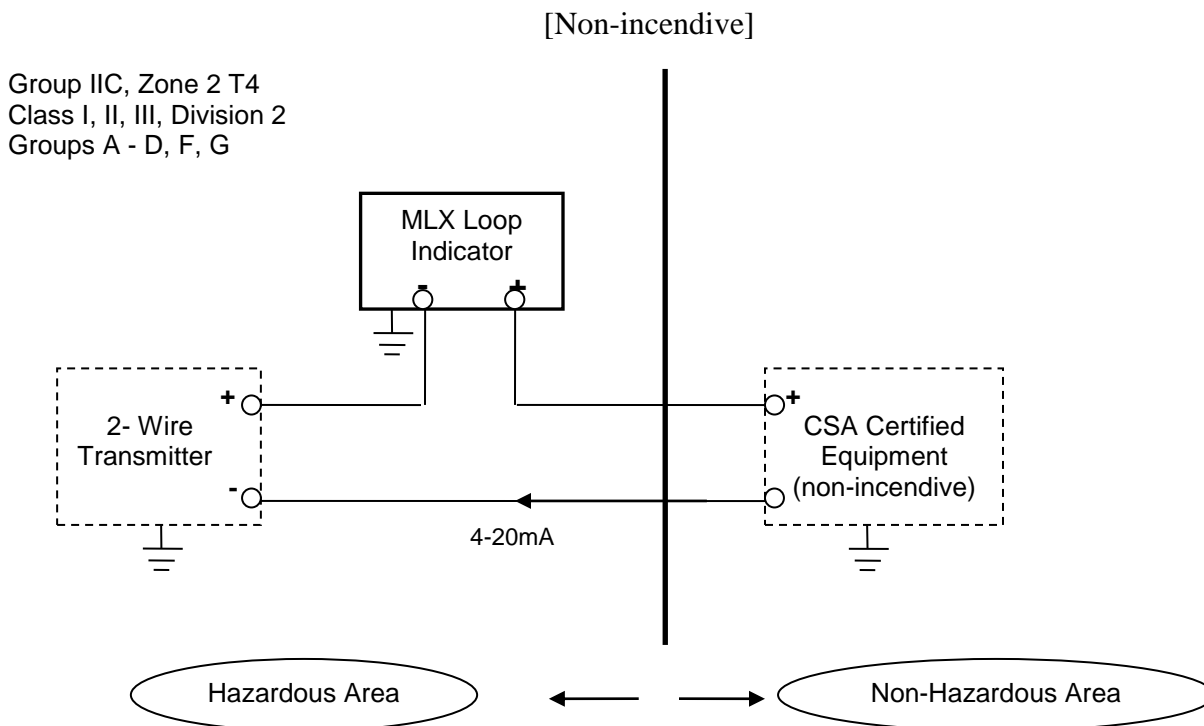

2.6.4 IECEx Certification

1) Technical Data

a. IECEx Intrinsically Safe/IECEx Flameproof/ IECEx Non-Incendive Type

Caution for IECEx Intrinsically Safe/ IECEx Flameproof/ IECEx Non-Incendive Type.

Note 1. Model MLX Loop Process Indicator with optional code /SU2 are applicable for use in potentially hazardous locations.

- Certificate No. IECEx ETL 13.0028X
- Certificate No. IECEx ETL 13.0029X
- Certificate No. IECEx ETL 13.0030X
- Applicable Standard: EN 60079-0:2009, EN 60079-11:2007, EN 60079-26:2007
- Type of Protection and Marking code:
 - II 1G Ex ia IIC T4 Ga
 - II 2G Ex d IIC T4 Gb
 - II 2D Ex tb IIC T135 Db
 - II 3G Ex nA IIC T4 Gc

- Tamb. -40°C to 80°C
- Enclosure rating: IP66 and IP67

Note 2. Electrical Data

- In the case where the type of explosion protection is intrinsically safe, Ex ia IIC T4 Ga, only connect to a certified intrinsically safe circuit with the following maximum values:

$$U_i = 28 \text{ V}$$

$$I_i = 115 \text{ mA}$$

$$P_i = 0.65 \text{ W}$$

Effective internal capacitance; $C_i = 0$

Effective internal inductance; $L_i = 0$

- In the case where the type of explosion protection is Non-Incendive, Ex nA IIC T4 Gc, only connect to a certified intrinsically safe circuit with the following maximum values:

$$U_i = 30 \text{ V}$$

$$I_i = 150 \text{ mA}$$

$$P_i = 0.85 \text{ W}$$

Note 3. Wiring

- For an ambient temperature $\geq 70^{\circ}\text{C}$, heat resistant cables shall be used with a rating of at least 20°C above the ambient temperature.
- All wiring shall comply with local installation requirements. (Refer to the installation diagram)

Note 4. Installation

- Observe WARNING on nameplate. (Refer to the installation diagram)
WARNING: AFTER DE-ENERGIZING, DELAY 5 MIN BEFORE OPENING COVER.

Note 5. Maintenance and Repair

- The instrument modification or parts replacement by other than authorized representative of Yokogawa Electric Corporation is prohibited and will void Intrinsically Safe Certification.

Note 6. Special Conditions for Safe Use

- In the case where the enclosure of the MLX is made of aluminum, if it is mounted in an area requiring Category 1 G equipment (EPL Ga), it must be installed such that, in the event of rare incidents or rare malfunction, ignition sources due to impact and friction sparks are excluded.



WARNING

ELECTROSTATIC CHARGE HAZARD MAY CAUSE AN EXPLOSION. HAZARDS DUE TO THE PAINT THICKNESS OF THE EQUIPMENT NOT MEETING THE REQUIREMENTS FOR AVOIDING ELECTROSTATIC DISCHARGE ON GROUP II AND GROUP III ELECTRICAL EQUIPMENT. AVOID ANY ACTIONS THAT CAUSE AN ELECTROSTATIC DISCHARGE OF THE ENCLOSURE, SUCH AS RUBBING WITH A DRY CLOTH ON ANY SURFACE OF THE PRODUCT. PRECAUTIONS SHALL BE TAKEN TO MINIMIZE THE RISK FROM ELECTROSTATIC DISCHARGE OF PAINTED OR COATED PARTS OF EQUIPMENT

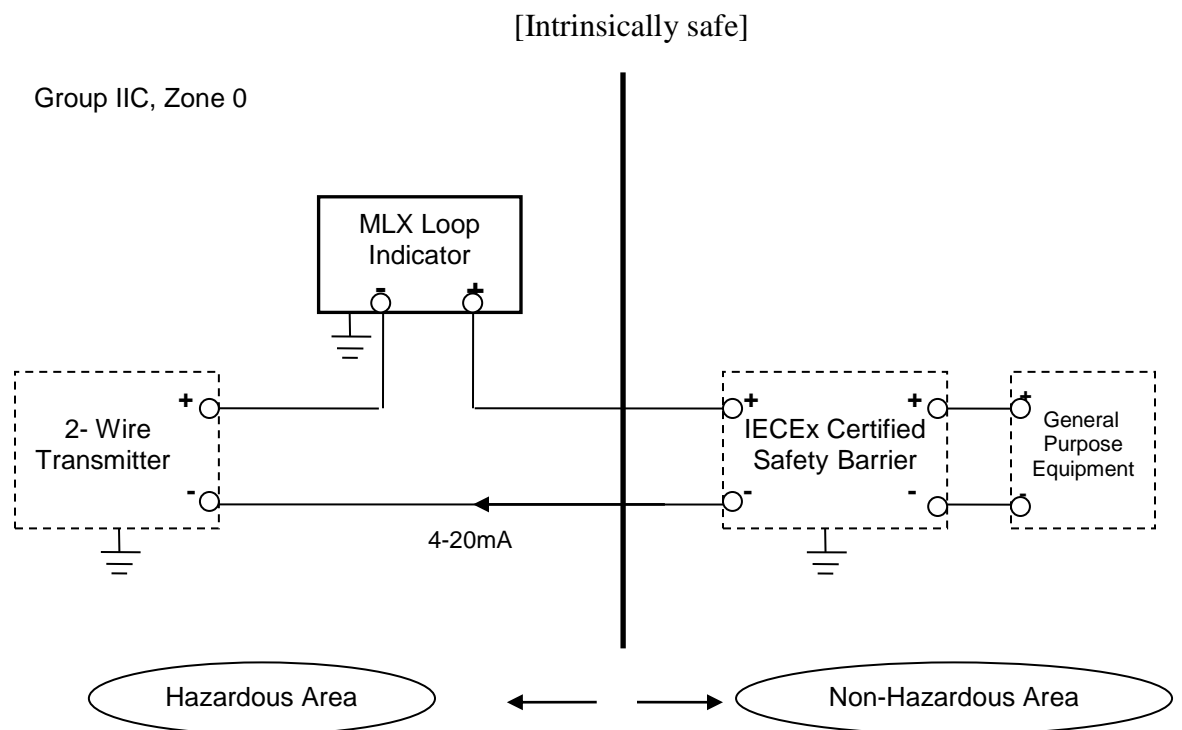

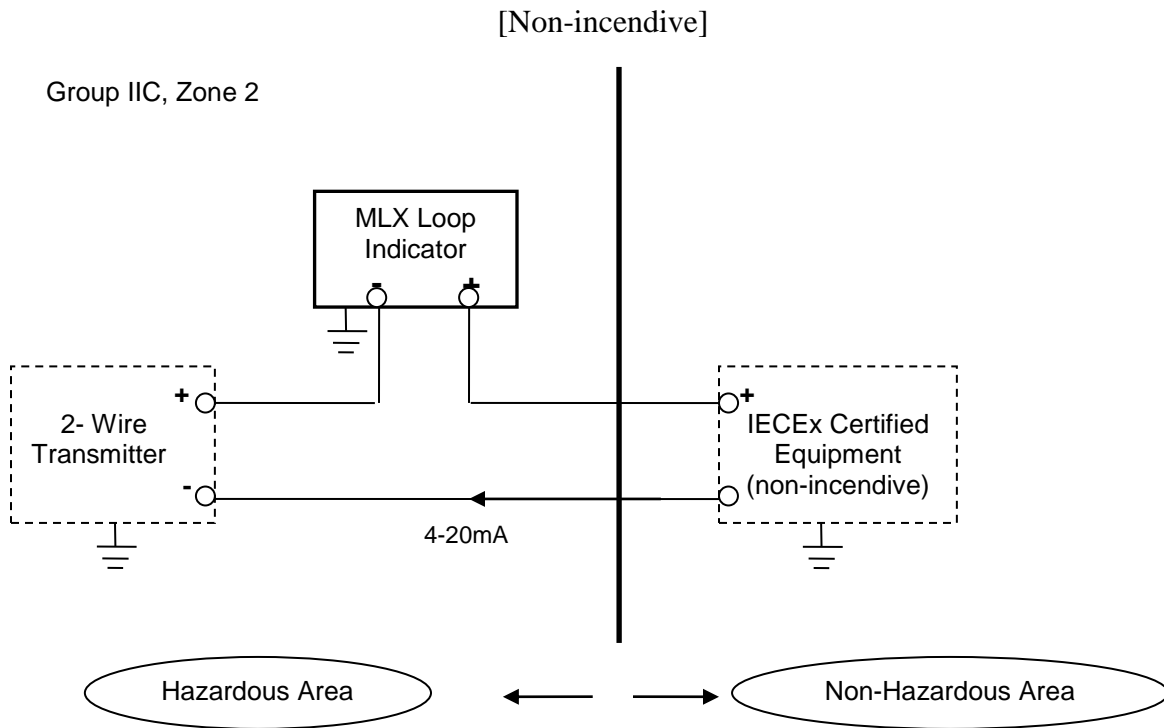

2.7 EMC Conformity Standards

EN61326-1 Class A, Table 2 (for use in industrial locations)



NOTE

YOKOGAWA recommends using metal conduit or twisted pair shielded cable for signal wiring to conform to the requirements of EMC regulations when installing the MLX in the plant.

2.8 Low Voltage Directive

Applicable Standard: EN61010-1

(1) Pollution Degree 2

“Pollution degree” describes the degree to which a solid, liquid, or gas which deteriorates dielectric strength or surface resistivity is adhering. “ 2 ” applies to normal indoor atmosphere. Normally, only non-conductive pollution occurs. Occasionally, however, temporary conductivity caused by condensation must be expected.

(2) Installation Category I

“Overvoltage category(Installation category)” describes a number which defines a transient overvoltage condition. It implies the regulation for impulse withstand voltage. “ I ” applies to electrical equipment which is supplied from the circuit when appropriate transient overvoltage control means (interfaces) are provided.

3. Installation

The MLX can be mounted on a wall or a 2" pipe. The housing is NEMA 4X/IP66/IP67 rated so it can be mounted outside in the field.

O-Ring seals **MUST** be carefully examined after opening to ensure that the NEMA 4X/IP66/IP67 protection is maintained. Damaged seals **MUST** be replaced.

The complete electrical circuit in the hazardous area **MUST** be capable of withstanding an AC test voltage of 500V RMS to earth or frame of the apparatus.

Where there is a possibility of attack by aggressive substances, the MLX must be protected by a suitable enclosure, capable of protecting it from the environment and the effects of impact, thermal or mechanical stress.

Do not install the MLX in the following conditions:

- Extreme Temperatures beyond the temperature rating of the instrument.
- High vibration areas above the vibration rating of the instrument.
- Extremely corrosive environments.

Installation **MUST** comply with the requirements specified in the appropriate standards and must be performed by suitably qualified staff only.

3.1 Mounting Examples

Vertical Pipe Mounting

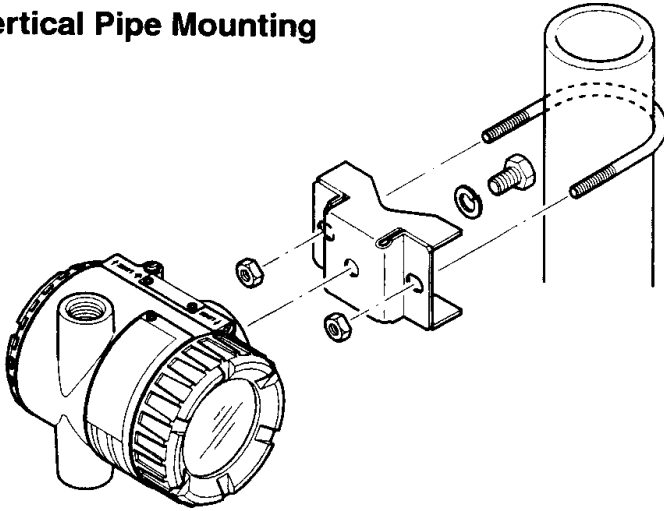

Horizontal Pipe Mounting

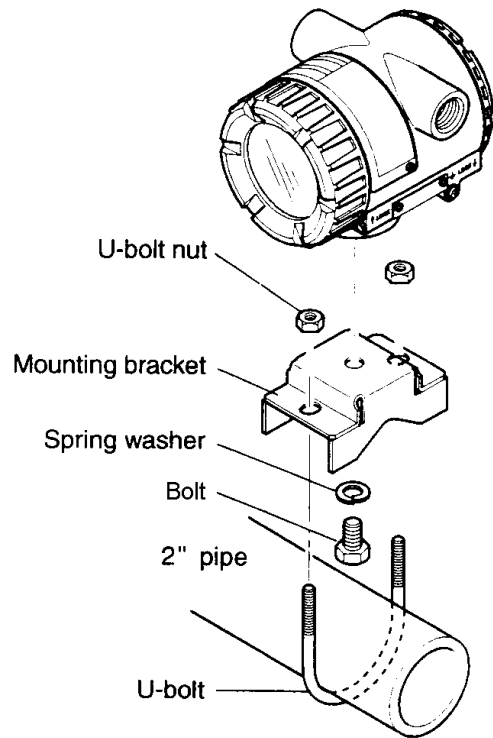

Wall Mounting

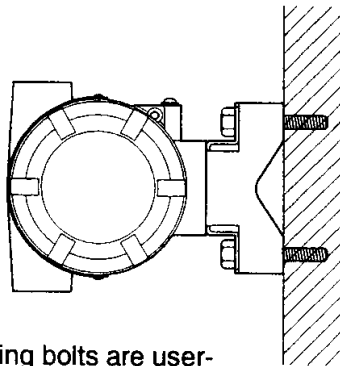

Note: Wall mounting bolts are user-supplied.

Figure 3.1 Mounting configurations

4. Wiring

4.1 Wiring Precautions



-
- For an ambient temperature $\geq 70^{\circ}\text{C}$, heat resistant cables shall be used with a rating of at least 20°C above the ambient temperature.
 - Lay wiring as far as possible from electrical noise sources such as large capacity transformers, motors, and power supplies.
 - Remove the electrical connection dust cap before wiring.
 - To prevent noise pickup, do not pass signal and power cables through the same ducts.
 - Explosion-protected instruments must be wired in accordance with specific requirements (and, in certain countries, legal regulations) in order to preserve the effectiveness of their explosion-protected features.
-

The MLX is powered by the current output loop and does not require external power. All devices must be wired in series with the current loop. Twisted pair shielded cable is recommended.

4.2 Selecting the Wiring Materials

- (a) Use stranded leadwires or cables which are the same as or better than 600 V grade PVC insulated wire or its equivalent.
- (b) For an ambient temperature $\geq 70^{\circ}\text{C}$, heat resistant cables shall be used with a rating of at least 20°C above the ambient temperature.
- (c) Use shielded wires in areas that are susceptible to electrical noise.
- (d) In areas with higher or lower ambient temperatures, use appropriate wires or cables.
- (e) In environment where oils, solvents, corrosive gases or liquids may be present, use wires or cables that are resistant to such substances.
- (f) It is recommended that crimp-on solderless terminal lugs (for 4 mm screws) with insulating sleeves be used for leadwire ends.

4.3 Wiring

4.3.1 Loop Configuration

The following is a typical wiring example of the MLX connected to an EJA Pressure Transmitter.

(1) General-use Type

(Note: The EJA Transmitter below can be replaced with any 4-20mA 2 wire device.)

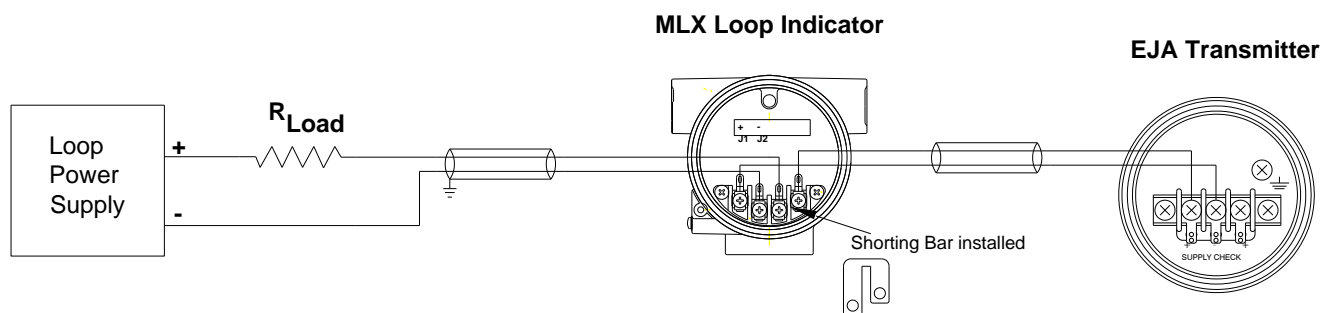

Figure 4.1 General-use Type wiring example

(2) HART Type

(Note: The HART Transmitter below can be replaced with any HART 4-20mA 2 wire device.)

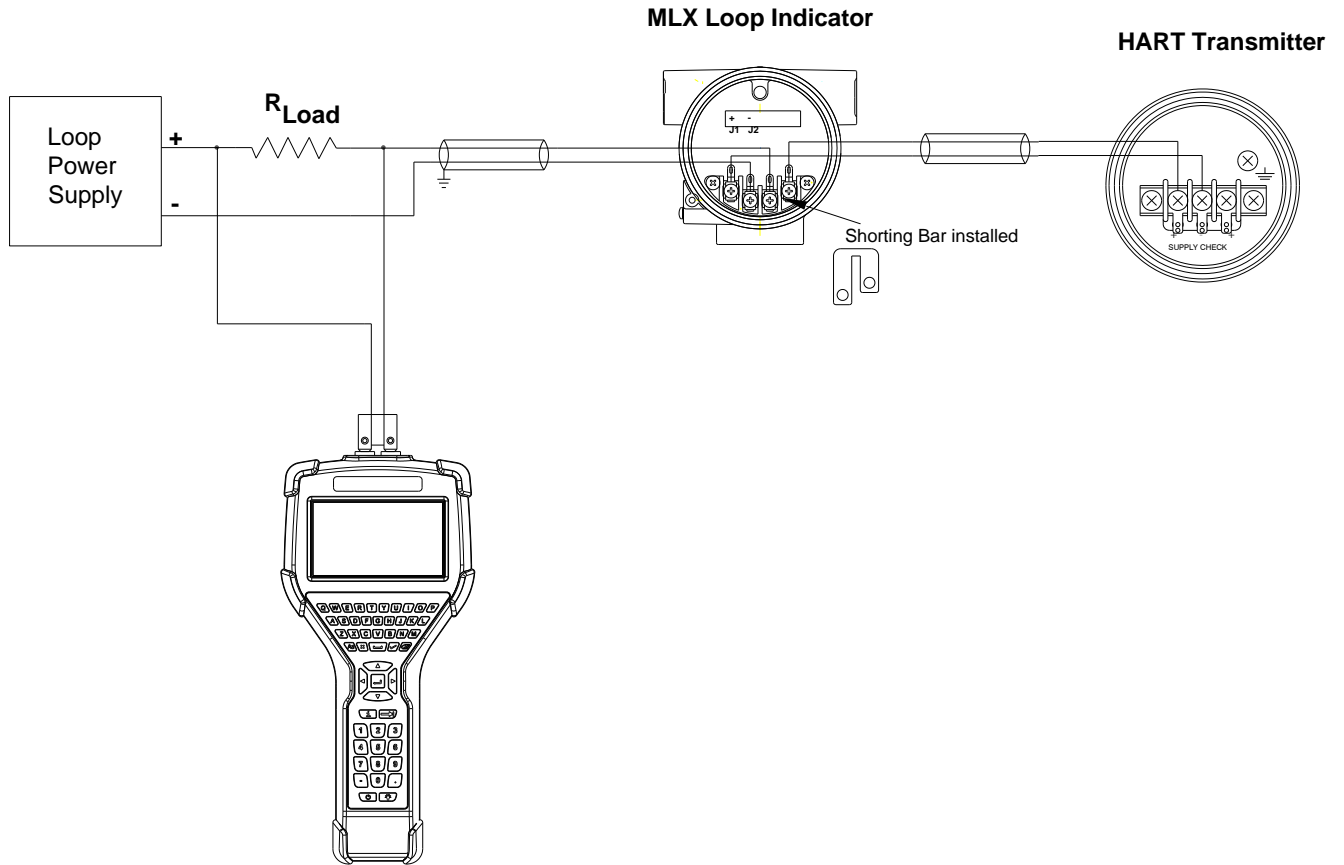

Figure 4.2 HART Type wiring example

5. Operation

5.1 Overview

The MLX is loop powered. Connect it in series with a 4-20mA loop as per Section 4 “Wiring”. Observe correct polarity as the indicator is protected against reversed connections but will not display a reading. After properly connecting the indicator to a transmitter or other 4-20mA source, the display will indicate the value of the current flowing in the loop (0-100% for the standard model or other specified engineering units can be user defined).



Connecting directly across a 28 V supply without a transmitter or similar device to regulate the loop current will result in damage to either the power supply or the MLX.

The MLX can easily be ranged to display virtually any engineering units by properly calibrating and selecting the desired units to be displayed.

The MLX uses a 4-key touchpad for operator input. Each key may have multiple functions assigned to it based a particular menu operation. These keys allow the user to access setup parameters, enter engineering units, zero and full-scale values, select display symbols and modify display functions. Figure 5.1 illustrates the keyboard.

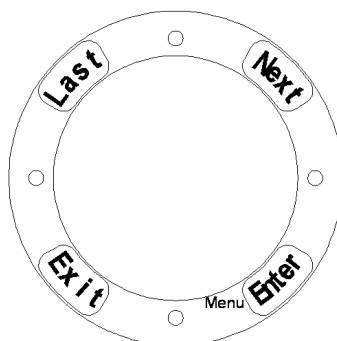

Figure 5.1 MLX 4-key Touch keypad.

Each key serves to navigate the menu systems and select a particular value or function. The overall function of each key is shown in Table 5.1.

Table 5.1 MLX key functions

Key	Function
Last	Selects the previous menu item or menu level
Next	Selects the next menu item or menu level
Enter	Selects the current menu item or menu level
Exit	Exits the menu item or menu level and returns the MLX to normal functions.

Listing 1. MLX Menu Tree

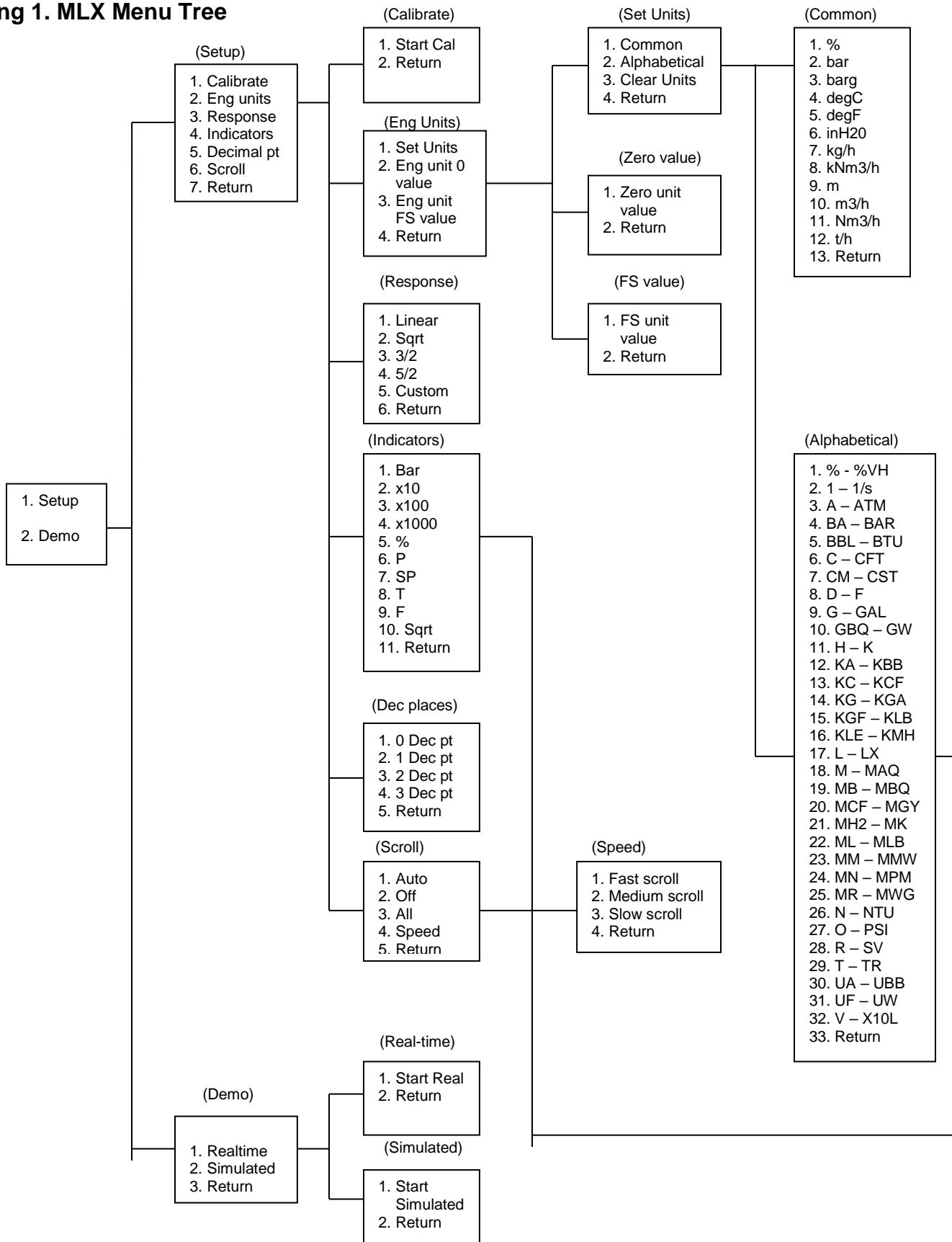

MLX Menu Tree (cont.)

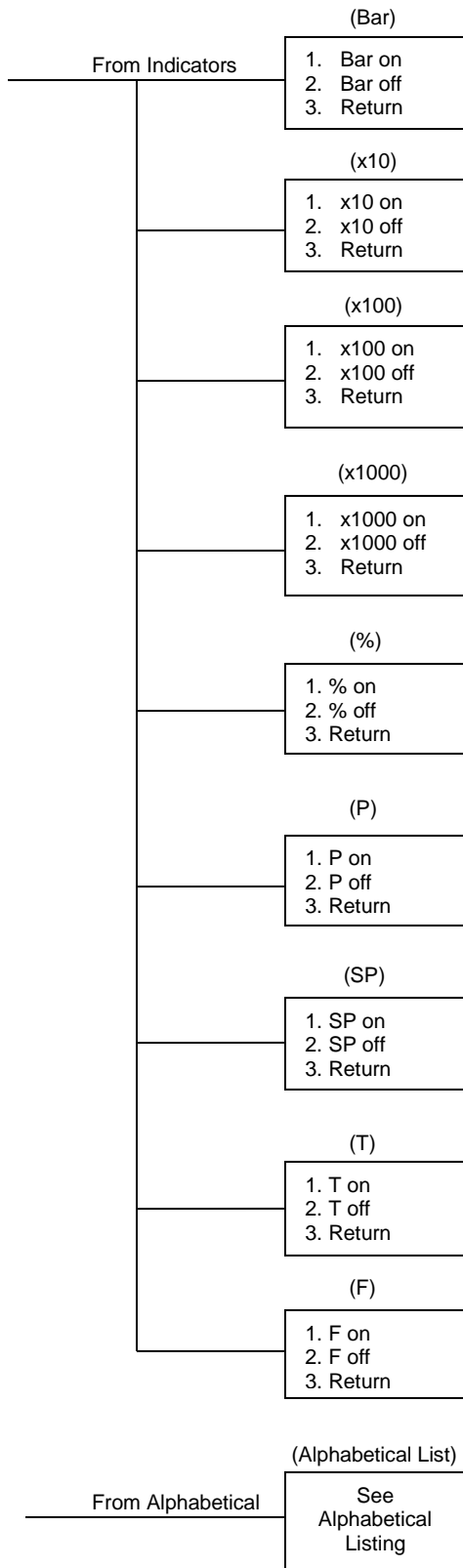

Listing 2. Alphabetic units

List of alphabetical engineering units (from Alphabetical)

%	BRIX	dm ²	GW.h	kg
%C	BTU/SCF	ELm	h	kg/cm ²
%CH ₄	c/s	F	H ₂ %	kg/cm ² abs
%CO	cal	FNU	HL/H	kg/cm ² G
%CO ₂	cal/kWh	foot	hPa	kg/d
%CP	CC/MIN	foot/p	hPaabs	kg/h
%H ₂	Cel	foot/s	hPaG	kg/l
%H ₂ O	CelD.P.	footAq	Hz	kg/m ²
%LEL	cf/d	footAqabs	in	kg/m ² G
%N ₂	cf/h	footH ₂ O	in/s	kg/m ³
%O ₂	cf/min	footH ₂ Oabs	inAq	kg/min
%R.H.	cf/p	ftH ₂ O	inAqabs	kg/mm ²
%RF	cf/s	ftH ₂ Oabs	inAqG	kg/mm ² G
%RH	CFM	g	inH ₂ O	kg/p
%RV	cft/min	g/cm ²	inH ₂ Oabs	kg/s
%VH	cm	g/cm ² G	inH ₂ OG	kgal/d
1/min	cm/min	g/cm ³	inHg	kgal/h
1/s	cm/s	g/d	inHgabs	kgal/min
A	cm ²	g/h	inWC	kgal/p
ABS	cm ³	g/l	inWCabs	kgal/s
at	cm ³ /d	g/m ²	inWG	kgf
ata	cm ³ /h	g/m ³	inWGabs	kgf.m
atg	cm ³ /min	g/min	J	kgf/cm ²
atm	cm ³ /p	g/ml	K	kgf/cm ² abs
BACARA	cm ³ /s	g/mm ²	kA	kgf/cm ² G
bar	cmAq	g/mm ² G	kbb/d	kgf/m ²
BARA	cmAqabs	g/Nm ³	kbb/h	kgf/m ² G
barabs	cmAqG	g/p	kbb/min	kgf/mm ²
bare	cmH ₂ O	g/s	kbb/s	kgf/mm ² G
bareG	cmH ₂ Oabs	G/T	kbb_b/d	kgfm
barG	cmH ₂ OG	gal/d	kbb_b/h	kHz
bbl/d	cmHg	gal/h	kbb_b/min	kJ
bbl/h	cmHgabs	gal/min	kbb_b/p	kl
bbl/min	CO ₂ ppm	gal/p	kbb_b/s	kl/d
bbl/s	COS	gal/s	kbb_o/d	kl/h
bbl_b/d	cP	GBq	kbb_o/h	kl/min
bbl_b/h	cpm	Gcal/h	kbb_o/min	kl/p
bbl_b/min	cps	gf	kbb_o/p	kl/s
bbl_b/p	cSt	gf.m	kbb_o/s	klb/d
bbl_b/s	d	gf/cm ²	KC/NM ₃	klb/h
bbl_o/d	D.P.	GHz	kcal	klb/min
bbl_o/h	dB	GJ	kcal/Nm ³	klb/p
bbl_o/min	deg	GJ/h	kcf/d	klb/s
bbl_o/p	degF	GOhm	kcf/h	KLEENH
bbl_o/s	degR	GPM	kcf/min	klx
BPD	degree	gpm	kcf/p	km
Bq/cm ²	DEWPOINT	GW	kcf/s	km/h
Bq/cm ³				

km3	m/p	mgal/d	mmHg	N/m2abs
km3/d	m/s	Mgal/h	mmHgabs	N/m2G
km3/h	m/s2	mgal/h	MMHO	N2ppm
km3/min	m2	Mgal/min	mmol/l	nA
km3/s	m3	mgal/min	mmP-P	nF
km3N/h	m3/d	Mgal/s	MMSCFD	nGy/h
KMHO	m3/h	mgal/s	mmWC	Nkm3/d
kN	m3/min	Mgal_p	mmWCabs	Nkm3/h
kN.m	m3/p	mgal_p	mmWG	NI/h
kN/m2	m3/s	mGy/h	mmWGabs	NI/min
kN/m2abs	m3N/h	mH2O	MN	NI/s
kN/m2G	mA	mH2Oabs	mN	Nm3/d
kNm3/h	mAq	mH2OG	mN.m	Nm3/h
knot	mAqabs	mHg	MN/m2	Nm3/min
kOhm	mAqG	mHgabs	MN/m2G	Nm3/s
kPa	mb	MHO	MNGF	ns
kPaabs	mbar	MHO/CM	MOhm	nSv/h
kPaG	mbarabs	MHz	mOhm	NTU
kt	mbare	micron	MOhm.cm	Ohm
kt/h	mbareG	min	MOhm/cm	Ohm.cm
kV	mbarG	min-1	mol	Ohm-1
kvar	mbbl/d	MJ	MOLWT	OPm
kW	mbbl/h	mJ	MPa	P
kW.h	mbbl/min	MJ.m-2	mPa	Pa
kW.m-2	mbbl/s	MJ/m2	mPa.s	pA
kW/m2	mbbl_b/d	MJ/Nm3	MPaabs	Paabs
KWH/M3	mbbl_b/h	mK	mPaabs	PaG
l	mbbl_b/min	ml	MPaG	pF
L.E.L.	mbbl_b/p	MI/d	mPaG	pF/m
l/d	mbbl_b/s	MI/h	MPM	pH
l/h	mbbl_o/d	ml/h	mR/h	ppb
l/min	mbbl_o/h	MI/min	mS	PPHM
l/p	mbbl_o/min	ml/min	ms	ppm
l/s	mbbl_o/p	MI/p	mS/cm	ppmCO
lb	mbbl_o/s	MI/s	mS/m	ppmCO2
lb/cf	mBq	ml/s	MSCFD	ppmH2S
lb/d	mcf/d	MLB/H	MSI/CM	ppmN2
lb/gal	mcf/h	mm	mSv/h	ppmNOX
lb/h	mcf/min	mm/h	Mt/h	ppmO2
lb/in2	mcf/p	mm/min	MV	ppmSO2
lb/min	mcf/s	mm/s	mV	psi
lb/p	mF	mm2	Mvar	psia
lb/s	Mg	mm3	MW	psiabs
lbf/in2	mg	mmAq	mW	psig
lbf/in2abs	mg/cm2	mmAqabs	MW.h	R.M°
lbw/in2	mg/l	mmAqG	MW/m2	R/h
lx	MG/LO2	MMAT	mWC	R/min
m	MG/LT	MMCE	mWG	rad
m/h	mg/m3	mmH2O	N	rpm
M/H2	mg/Nm3	mmH2Oabs	N.m	rps
m/min	Mgal/d	mmH2OG	N/m2	S

s	ubbl_b/d	uS/m
S.G.	ubbl_b/h	USI/CM
s-1	ubbl_b/min	uSv/h
SCFH	ubbl_b/p	uV
SCFM	ubbl_b/s	uW/cm2
Sm3/h	ubbl_o/d	V
St	ubbl_o/h	VAC
Sv/h	ubbl_o/min	var
t	ubbl_o/p	vol%
t/d	ubbl_o/s	vol%O2
t/h	uF	volpct
t/min	ug	W
t/p	ug/l	W.h
t/s	ug/m3	W.s
TF	uGy/h	W/m2
THz	uHg	wt%
TM	um	wtpct
Torr	UMHO	wtpctS
TPm	UMHO/CM	wtppb
TR/min	umP-P	wtppm
uA	uOhm	X10L
ubbl/d	uPa	
ubbl/h	uS	
ubbl/min	us	
ubbl/s	uS/cm	

Listing 3. Common Units

%
 bar
 barg
 degC
 degF
 inH2O
 kg/h
 kNm3/h
 m
 m3/h
 Nm3/h
 t/h

5.2 Setting Engineering Units

The standard configuration of the MLX sets the engineering units to 0-100% with two decimal places. Also, after calibration, the MLX will be set to 0-100% with two decimal places. (Refer to the Maintenance section for instructions on calibrating the MLX.) If other engineering units are desired, they must be setup. The following procedure illustrates an example of using units of 200-400 m³/h.

IMPORTANT

Before setting the engineering units full scale value, be sure to first set the number of decimal places (selected from the “Decimal point” menu). If the decimal places are not set first, the desired full scale value may be unable to be set. For example, the factory default setting of the MLX is 0 – 100% with 2 decimal places. If a new full scale value of 100000 is desired and the number of decimal places is not set to 0, the maximum value that can be set is 9999.99. (The display has six digits. If there are two decimal places, only four digits remain for adjustment.)

Set decimal places first when setting engineering full scale value.

- (a) Touch the “Menu” button to enter the menu system.
The alphanumeric display reads “Setup”.
- (b) Touch **Enter** to begin the setup routine.
The alphanumeric display reads “Calibrate”.
- (c) Touch **Next** to advance to the next menu item.
The alphanumeric display reads “Eng units”.
- (d) Touch **Enter** to select the Eng units routine.
The alphanumeric display reads “Set Units”.
- (e) Touch **Enter** to select the Units routine.
The alphanumeric display reads “Common”. The choices here are:
 1. Common units – Use to select units from a common set of units
 2. Alphabetical – Use to select units from an alphabetical list
 3. Clear Units – Use to clear selected units when it is desired to display no units
 Touch **Enter** to select “Common” or **Next** to select another desired method. In this example, we will use Common units.
- (f) Touch **Enter** to select “Common” units.
The alphanumeric display reads “%”.
- (g) Touch **Next** repeatedly to scroll forward through the units (or **Last** to scroll backwards).
- (h) When the desired unit is shown (in this case, m³/h), touch **Enter** to select the unit.
The alphanumeric display shows “Units = m3h” for a few seconds. Then the alphanumeric display shows “Eng unit 0 value”. At this point, the zero value for the range can be set (i.e. in this example, the range is 200 to 400. So the zero value is 200.)
- (i) Touch **Enter** to select “Eng unit 0 value”.
The alphanumeric display reads “Zero Unit Value”.
- (j) Touch **Enter** to set the zero value.

The numeric display shows the current engineering unit zero value with the least significant digit blinking. At this point, the menu buttons are redefined as in Table 5.2.

Table 5.2 MLX key functions (when in Engineering units mode)

Key	Function
Last	Selects the digit to modify (digits advance from least significant to most significant to the sign symbol and back to least significant – 6 digits plus sign).
Next	Increments the selected digit (values roll over from 9 to 0).
Enter	Decrements the selected digit (values roll over from 0 to 9).
Exit	Accepts the modified value as the current engineering unit zero or full-scale (FS) value.

- (k) Touch **Next** to increment the least significant digit to the desired valued (the digits roll over from 9 to 0).
- (l) Touch **Last** to move to the next digit.
- (m) Touch **Next** to increment the selected (blinking) digit to the desired valued (or Touch **Enter** to decrement the selected digit).
- (n) Repeat Steps (l) and (m) until desired value is indicated (including sign value) In this example, set to 200.
- (o) Touch **Exit** to accept the entered value as the engineering units zero value.
The alphanumeric display shows “Eng units 0 value”. The numeric display shows the current engineering unit zero value.
- (p) Touch **Next** to move to the next menu item.
The alphanumeric display reads “Eng units FS value”.
- (q) Touch **Enter** to set the Full Scale (FS) value.
The numeric display shows the current engineering unit FS value with the least significant digit blinking.
- (r) Repeat Steps (k) through (o) set the engineering units FS value (in this example, set to 400).
- (s) Touch **Exit** to end the engineering units setting process.
The alphanumeric display reads “Return”.
- (t) Touch **Exit** to exit the setup routine, save the new values and resume measurements.
The alphanumeric display shows the units selected during set up. The numeric display resumes displaying measured values.

6. Maintenance

6.1 Overview

The electronics of the MLX is maintenance free. This chapter describes the procedures for calibration and rotating the display within the enclosure. Please carefully and thoroughly read the following sections for information on how to perform these maintenance procedures.

6.2 Calibration Instruments Selection

Table 6.1 lists the instruments that can be used to calibrate the MLX. When selecting an instrument, consider the required accuracy level. Exercise care when handling these instruments to ensure they maintain the specified accuracy.

6.3 Calibration

The MLX is factory calibrated to 0-100%. Products ordered with the /ENG Engineering Units option other than 0-100% use 0-100% as the basis for the desired engineering units. Use the procedure below to check instrument operation and accuracy during periodic maintenance or troubleshooting.

- (2) Connect the instruments as shown in Figure 6.1 (red wire to + OUT on current source, black wire to - OUT on current source) and warm up the instruments for at least five minutes.

Table 6.1 Instruments Required for Calibration

Name	Yokogawa-recommended Instrument	Remarks
Current Standard	Model CA150 Calibrator or Model CA450 Process Multimeter	4-20mA source

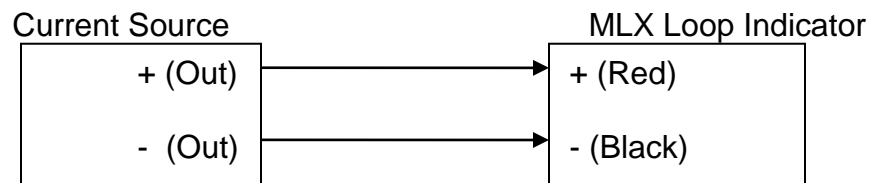

Figure 6.1 Calibrating the MLX

- (3) Using the values in Table 6.2, check the MLX readings by setting the current source to each of the table values. Check all points in the table and verify unit is within specification.

Table 6.2 Percent vs. Current Values

Value	Current
0%	4.0mA
25%	8.0mA
50%	12mA
75%	16mA
100%	20mA

- (4) If a re-calibration is required, use the following method:
- Touch the “Menu” button to enter the menu system.
The alphanumeric display reads “Setup”.
 - Touch **Enter** to begin the setup routine.
The alphanumeric display reads “Calibrate”.
 - Touch **Enter** to begin the calibrate routine. Follow the instructions given on the display. For each calibration point, after adjusting the current standard to the value indicated, press the “Menu” button.

6.4 Rotating Display Direction

The MLX display is designed so that it can be rotated in increments of 90 degrees. When there is a need to change the orientation of the display, use the following procedure:

- (1) Remove power from the MLX.
- (2) Remove the glass cover from the display side.
- (3) Remove the two anchor nuts from the MLX module assembly.
- (4) Remove and rotate the display assembly to the desired orientation.
- (5) Re-install and tighten the two nuts on the module assembly.
- (6) Replace the glass cover.

6.5 Cleaning

Cleaning should be restricted to wiping with a damp cloth or approved anti-static cleaner to avoid the danger of ignition due to electrostatic charges.

7. General Specifications

7.1 Standard Specifications

□FUNCTIONAL SPECIFICATIONS

Input: 4-20mA DC 2-wire

Voltage Drop: 3.5V at 20mA

LCD Display

Numerical: Six 7-segment digits

Alpha-numerical: Six 14-segment characters

Bar graph: 20-segment Bar graph.

Symbols: P, SP, T, F, %, $\sqrt{\quad}$, x10, x100, x1000

Configuration: User configurable for desired engineering units.

Method: User configurable from front panel

Zero & Span: Zero and span can be set between ± 999999 .

Turn-on Time: 12 second (includes power on self-test and memory integrity check)

Update Time: 1 second

Isolation: Input/Output/Ground isolated to 500V DC

□PERFORMANCE SPECIFICATIONS

Accuracy: $\pm 0.05\%$ of full scale +1 digit

Operating Current: 3.6mA to 28mA

Ambient Temperature: -40 to +80°C (-40 to 176°F)

Ambient Humidity: 0 to 100%RH at 23°C (73°F)

Ambient Temperature Effect: 0.1°C per 10°C

Over range: 200mA without damage

Maximum error: +0.02%, -0.03% (of full scale)

Conformity (Linearity): 0.03%

Hysteresis error: 0.03%

Repeatability: 0.03%

Vibration: 3G @ 10-150Hz

Shock: 50G

Explosion Protection: FM, CSA, ATEX, and IEC

□PHYSICAL SPECIFICATIONS

Enclosure

Material

Housing: Low copper cast aluminum alloy with Polyurethane resin baked finish - Deep sea moss green (equivalent of Munsell 0.6GY3.1/2.0) or SUS316 cast stainless steel (ASTM CF-8M)

Name plate: 316 SST

Tag: 316 SST

Wired tag: 316 SST

Degrees of Protection: NEMA 4X, IP66 and IP67

Mounting: Nominal 2" (50mm) pipe mount or surface. (horizontal or vertical)

Weight: 1.25kg (2.70 lbs)*

*: Without mounting bracket

Add 0.8 kg (0.35 lbs) for mounting bracket

Electrical Connection: ½ x 14 NPT female or M20 x 1.5 female

□FEATURES

User interface

A front panel push button switch combined with four touch switches allows easy configuration of the indicator (calibration, span, zero and engineering units).

Root extraction

For applications where the process variable is non-linear and based on the square root, $3/2$ root or $5/2$ root, the MLX can be configured to display the root function of the input.

Field Configurable

Via the front panel user interface, the process variable parameters can be modified as desired in the field.

LCD Display features

The LCD display includes a bar graph for an analog indication of the process variable magnitude. The 6 digit display and 6 character display (combined with several symbols) give an instant view of all process variable parameters. A menu system allows customizing parameters such as decimal point position, engineering units, status of symbols and state of bar graph.

Self-diagnostics

Built-in diagnostics operate at power-up and during operation for ease of maintenance and troubleshooting.

EMC Conformity Standard: CE

EN61326-1 Class A, Table 2

(For use in industrial location)

Built-in Loop Protection

Includes circuitry that, in the event of MLX failure, automatically takes the MLX out of the loop thus maintaining loop integrity.

EMC Conformity Standard: CE

EN61326-1 Class A, Table 2

(For use in industrial location)

7.2 Model and Suffix Codes

MODEL AND SUFFIX CODES

Model	Suffix Codes	Description
MLX	Loop Indicator
Input signal	-A	4 to 20mA DC
Mounting	1	2 inch Horizontal Pipe
	2	2 inch Vertical Pipe (or wall mount)
Housing	1	Cast aluminum alloy
	2	SUS316 cast stainless steel and ASTM CF-8M ¹
Communication	-1	Standard
Electrical Connection	0	ANSI ½ - 14NPT female, two electrical connections without blind plug
	2	ANSI ½ - 14NPT female, two electrical connections and one 316 SST blind plug
	3	ISO M20 x 1.5 female, two electrical connections without blind plug
	4	ISO M20 x 1.5 female, two electrical connections and one 316 SST blind plug
	5	ISO G1/2 x 14 female, two electrical connections without blind plug
	6	ISO G1/2 x 14 female, two electrical connections and one 316 SST blind plug
Optional Codes		/ <input type="checkbox"/> Optional specification

OPTIONAL SPECIFICATIONS (For Explosion Protected Type)

Item	Description	Code
Factory Mutual (FM)	FM Explosion-proof/FM Dust-Ignition-Proof Approval Conforms to: FM3600, FM3615, UL 1203 Explosionproof/Dust-Ignition-Proof for Class I, II, III, Division 1 & 2, Groups A - G, Class I, Zone 1, Group IIC T4 Ambient Temperature: -40 to 80°C (-22 to 176°F) Temperature class: T4	FF1
	FM Intrinsically Safe/FM Explosion-proof/ FM Dust-Ignition-Proof /FM Non-incendive Approval Conforms to: FM3600, FM3610, FMRC 3611, FM 3615, FM 3616, UL 913, UL 1203, UL 60079-0, UL 60079-11 Intrinsically Safe for Class I, II, III, Division 1 & 2, Groups A - G, Zone 20, Class I, Zone 0, AEx ia IIC, T4 Ga -40°C < Ta < 80°C (-40 to 176°F) Explosion-proof/Dust-Ignition-Proof for Class I, II, III, Division 1 & 2, Groups A - G, Class I, Zone 1, Group IIC T4 Amb. Temp.: -40 to 80°C (-40 to 176°F) Non-incendive for Class I, II, III, Division 2, Groups A - D, F, G, Class I, Zone 2, Group IIC T4 Enclosure: "NEMA 4X", Temp. Class: T4, Amb. Temp.: -40 to 80°C (-40 to 176°F) Intrinsically Safe Apparatus Parameters [Groups A - G] Vmax=28 V, Imax=115 mA, Pmax=0.65 W, Ci=0 nF, Li=0 H Non-Incendive Apparatus Parameters [Groups A - D, F, G] Vmax=30 V, Imax=150 mA, Pmax=0.85 W	FU1
ATEX	ATEX Intrinsically Safe/ATEX Flameproof/ATEX Non-incendive Approval Flameproof Applicable Standard: EN 60079-0, EN 60079-11, EN 60079-31 II 1G Ex ia IIC T4 Ga Entity parameters : Ui=28 V, li=115 mA, Pi=0.65 W, Ci=0 nF, Li=0 H II 2G Ex d IIC T4 Gb II 2D Ex tb IIIC T135 Db II 3G Ex na IIC T4 Gc Entity parameters : Ui=30V, li=150 mA, Pi=0.85 W Degree of protection : IP66 and IP67 Temperature class: T4, Ambient Temperature: -40 to 80°C (-40 to 176°F)	KU21

OPTIONAL SPECIFICATIONS (For Explosion Protected Type)

Item	Description	Code
Canadian Standards Association (CSA) Canadian Standards Association (CSA)	<p>CSA Intrinsically Safe/CSA Explosionproof/ CSA Dust-Ignition-Proof /CSA Non-incendive Approval Certified to: CSA C22.2 No. 25, CSA C22.2 No. 30, CSA C22.2 No. 157, CSA C22.2 No. 213, CSA C22.2 No. 60079-0, CAN/CSA E60079-11</p> <p>Explosionproof/Dust-Ignition-Proof for: Class I, II, III; Groups A - G; Divisions 1 & 2. Class I, Zone 1, Group IIC T4. Tamb. -40°C to 80°C</p> <p>Intrinsically Safe for: Class I, Division 1, II, III; Groups A - G; Divisions 1 & 2. Zone 20, Class I, Zone 0 AEx ia IIC T4 Tamb. -40°C to 80°C Entity parameters: Ui=28 V, li=115 mA, Pi=0.65 W, Ci=0 nF, Li=0 H</p> <p>Non-Incendive for: Class I, II, III; Groups A - D, F, G; Divisions 2. Class I, Zone 2, Group IIC T4. Tamb. -40°C to 80°C Entity parameters: Ui=30 V, li=150 mA, Pi=0.85 W</p> <p>Enclosure rating: "Type 4X." Temperature Class: T4 Ambient Temperature: -40°C to 80°C</p>	CU1
IECEX Scheme	<p>IEC Intrinsically Safe/IEC Flameproof/IEC Non-Incendive Approval Applicable Standard: IEC 60079-0:2011, IEC 60079-1:2008, IEC 60079-11:2011, IEC 60079-26:2009, IEC 60079-31:2008</p> <p>Explosionproof/Dust-Ignition-Proof for: Ex d IIC T4 Gb Ex tb IIIC T135 Db</p> <p>Intrinsically Safe for: Ex ia IIC T4 Ga Entity parameters: Ui=28 V, li=115 mA, Pi=0.65 W, Ci=0 nF, Li=0 H</p> <p>Non-Incendive for: Ex nA IIC T4 Gc Entity parameters: Ui=30 V, li=150 mA, Pi=0.85 W</p> <p>Ambient Temperature: -40°C to 80°C Enclosure: IP66 and IP67</p>	SU2
Combination of Approvals	Combination of FU1, CU1 and KU21 Approvals	V1U

OPTIONAL SPECIFICATIONS

Item	Description	Code
Coating ^{*2}	Epoxy resin coating	X1
	Polyurethane-Epoxy Anti-corrosion coating	X2
Calibration	Calibration range and scale	ENG
Stainless steel tag plate	Stainless steel tag screw attached to housing	SST
	Stainless steel tag wired to housing	SSW
Paint ^{*3}	Light Blue (RAL # 5012)	P1
	Orange (RAL # 2008)	P2
	Red (Munsell # 7.5 R4/14)	P3
	Mint Green (CC55)	P4
	Silver (RAL # 9006)	P5
	Yellow (RAL # 1018)	P6
	Gray (RAL # 7046)	P7

- *1 Consult factory availability for Housing code 2.
- *2 Some coating options available via Tokuchu and may require additional lead time. Consult factory for further information.
- *3 Some painting options available via Tokuchu and may require additional lead time. Consult factory for further information.

ORDERING INFORMATION

Specify the following when ordering:

1. Model and suffix codes.
2. Option codes.
3. Tag number
4. Calibration range desired (optional)

Example Ordering Information:

MLX-A11-10/FF1/ENG/SST

(Field Mounted Loop Indicator, 4 to 20mA DC, 2" Horizontal Pipe mount, aluminum housing, standard communication, ANSI 1/2 NPT electrical connection without blind plugs, FM Explosion-proof approval)

0-200 InH2O

Scale in Engineering Units. Please specify Scale and Engineering units when ordering /ENG.

FT-201

Specify Tag Number when ordering /SST and/or /SSW.

OPTIONS

The MLX is fully field configurable from the front panel. To order a pre-configured unit, specify the /ENG option followed by the desired setpoints (zero, full scale, and engineering units).

7.5 Dimensions

Unit: mm (Approx. inch)

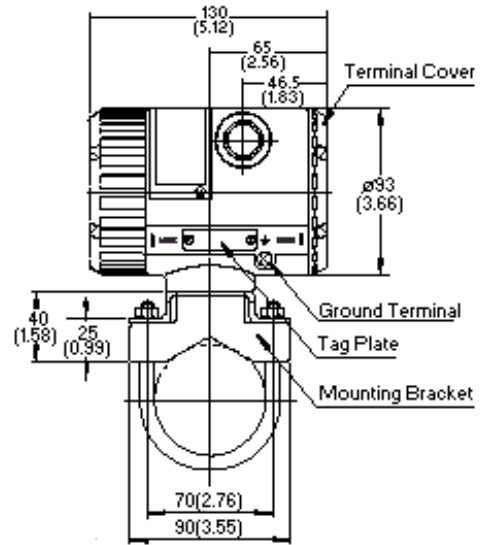
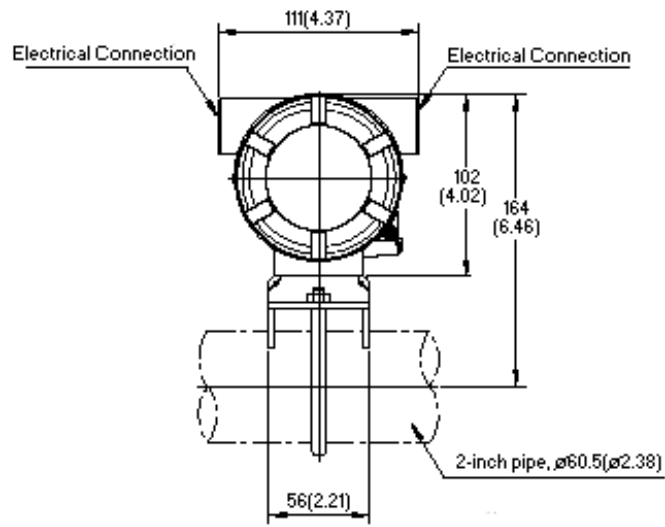



Doc. No.: AENA005-C01

EU DECLARATION OF CONFORMITY

We: **Yokogawa Corporation of America**
2 Dart Road, Newnan, GA 30265

declare under our sole responsibility that the products identified with:

Model Code Model Name
MLX **Current Loop Indicators**

As part of Product Family: **MLX**
Further specified with suffix- and option-codes:

As listed in General Specification: GS 60A02S01-01E-A (Ed. 9)

Are in compliance with the EU law and legislation providing for the CE-marking, as listed in Appendix 1.

Information relevant to the conformity and identification of these Products is provided in Appendix 2 and Appendix 3.

Subject products are:

- Produced according to appropriate quality control procedures.
- Provided with the CE-marking as from **2013**.

Signature:

(Manufacturer)
Newnan, 27 April, 2018

(Authorized Representative in the EEA)
Amersfoort, *26 October 2018*

Leo Harlan
General Manager
Manufacturing Engineering Dept.
Sourcing and Manufacturing Division
Yokogawa Corporation of America

Herman van den Berg
President
Yokogawa Europe B.V.
Euroewg 2, 3825 HD Amersfoort,
P.O. Box 163, 3800 AD Amersfoort,
The Netherlands

=====

Appendix 1



=====

The products are built in compliance with requirements of the following EU Directives and Standards:

Model – Suffix /Option code structure: **MLX – b c d e f / x**

(Distinctive combinations of suffix and option codes are indicated per table. Unless otherwise stated, it means that all the define code is relevant.)

EU Directive	Standards
2014/30/EU (EMC)	EN 61326-1:2006 Electromagnetic compatibility (EMC) – Part 1: General standards for electrical equipment for measurement, control and laboratory use
2014/35/EU (LVD)	EN 61010-1:2010 Safety requirements for electrical equipment for measurement, control and laboratory use
2011/65/EU (RoHS)	EN 50581:2012 Technical documentation of the assessment of electrical and electronic products with respect to the restriction of hazardous substances

EU Directive	Standards	-Suffix	/Option
2014/34/EU (ATEX)	Flameproof and Dust Ignition Proof type EN 60079-0:2012+A11:2013 EN 60079-1:2007 EN 60079-31:2009  II 2 G Ex d IIC T4 Gb II 2 D Ex tb IIIC T135°C Db		x = KU21
	The number of the EC Type-Examination Certificate: ITS13ATEX17857X/03		
	Intrinsically safe type (Ex ia) * EN 60079-0:2012+A11:2013 EN 60079-11:2012 EN 60079-26:2007  II 1 G Ex ia IIC T4 Ga The number of the EC Type-Examination Certificate: ITS13ATEX27856X/04		
	Non-incendive type (Ex nA) EN 60079-0:2012+A11:2013 EN 60079-15:2010		

	 <p style="text-align: center;">II 3 G Ex nA IIC T4 Gc</p> <p>The number of the Type-Examination Certificate: ITS13ATEX47858X/03</p>		
<p>EC Type Examination Certificates are issued by: The Name of the Notified Body: Intertek Testing & Certification Limited The Identification Number of the Notified Body: 0359 The Address of the Notified Body: Intertek House, Cleeve Road, Leatherhead, Surrey, KT22 7SB</p> <p>Quality Assurance Notification are issued by: The Name of the Notified Body: Dekra Certification B.V. The Identification Number of the Notified Body: 0344 The Address of the Notified Body: Meander 1051 6825 MJ Arnhem, The Netherlands The Number of Quality Assurance Notification: Dekra 13ATEXQ0174</p>			

Note: The revised (now harmonized) standards (EN 60079-1:2014, EN 60079-26:2015 and EN 60079-31:2014) have been compared to the standards used for certification purposes (EN 60079-1:2007, EN 60079-26:2007 and EN 60079-31:2009) and no changes in the “state of the art” apply to the equipment.

=====
Appendix 2
=====

This Product has no accessories.

User's Manual: **IM 60A02S01-01E-A** is an essential part of the product and is relevant to the conformity of the product as a part of the product.

Appendix 3

External view of MLX



Image of Product name plate
(Typical example; details may differ)

For Non-Explosion Protected Type (Read IM 60A02S01-01E-A)

LOOP POWERED INDICATOR		NO.	
		INPUT	4 - 20mA DC
MODEL	MLX	CAL	
SUFFIX		RNG	
MFG		ASSEMBLED IN USA WITH FOREIGN AND DOMESTIC PARTS	

M1275NB

YOKOGAWA ◆ Newnan, Ga. USA 1-800-888-6400

CE

For Explosion Protected Type (with /KU21) (Read IM 60A02S01-01E-A)

LOOP POWERED INDICATOR		NO.	
		INPUT	4 - 20mA DC
MODEL	MLX	CAL	
SUFFIX		RNG	
MFG		ASSEMBLED IN USA WITH FOREIGN AND DOMESTIC PARTS	

M1275EL

YOKOGAWA ◆ Newnan, Ga. USA 1-800-888-6400

CE 0344 Ex

Cert. No: ITS13ATEK27956X
 Cert. No: ITS13ATEK17957X
 Cert. No: ITS13ATEK47958X
 II 1G Ex ia IIC T4 Gc
 UI = 20V, Ii = 115mA, Pi = 0.85W, Ci = 0.01F, Li = 0.5mH
 II 2G Ex d IIC T4 Gc
 II 2D Ex ib IIC T105 Db
 II 3G Ex nA IIC T4 Gc
 UI = 20V, Ii = 150mA, Pi = 0.85W
 Temp. -40°C to +80°C
 Enclosure: IP66 and IP67

WARNING
 AFTER DE-ENERGIZING, DELAY 5 MIN BEFORE OPENING COVER WHEN THE AMBIENT TEMP. ≥ 70°C, USE HEATRESISTING CABLE RATED ≥ 90°C. INSTALL IN ACCORDANCE WITH THE INSTRUCTION MANUAL.

Revision Record

Title: MLX Loop Powered Process Indicator
Manual No.: IM 60A02S01-01E-A

Edition	Date	Page	Revised Item
1 st	January 2012	--	New publication
2 nd	March 2012	14, 21	Removed J12 reference; modified Specifications
3 rd	July 2013	11-22	Added ATEX, CSA and IEC. Changed Section 5.
4 th	March 2014	44-45	Add Note for X2 coating option, Add Paint codes, Correct dust approval for ATEX & IEC.
5 th	June 2014	44-45	Add EMC Standard. Remove pending options – HART, Russian and Brazilian Approvals
6 th	January 2015	22, 33, 44 & 46	Add “loop protection” statement, HART wiring and G1/2 connector
7 th	August 2015	13, 15, 19-22, 25, 46, 47	Change entity values and nameplate drawings. Added Certification Conditions for Blanking plugs
8 th	September 2017	12, 13, 14, 16, 17, 22, 24, 25, 27, 46, 47	Add notes for “X” condition on paint thickness. Add Non-Incendive entity parameters. Remove note from GS restricting /X2 paint option.
9 th	April 2018	2, 16, 47 19, 20 53 51 53	Remove CENELEC from reference to ATEX. Replace 359 Notified Body number with 344 on ATEX nameplate and Combined Approval nameplate. Replace “EC Type” with “Type” for Non-incendive Protection type. Add Declaration of Conformity. Add Intertek as Notified Body for EC Type Certificates
10 th	November 2018	39,40 45 47 48 49 51-55	Corrected Listing 2: Alphabetic Units line overlap error. Removed “Pending” designation from Explosion Protection. Changed name plate, tag, and wired tag to 316 SST. Added reference to Housing code 2. Removed INMETRO Approval. Added references to Coating and Paint options. Added footnotes. Corrected EU Declaration and Appendix page numbers.