



## EDS/EDM35, sHub®

EXCEPTIONAL PERFORMANCE FOR SERVO DRIVES:  
MOTOR FEEDBACK SYSTEMS WITH HIPERFACE DSL®

Motor feedback system rotary HIPERFACE DSL®

**SICK**  
Sensor Intelligence.

# EXCEPTIONAL PERFORMANCE FOR SERVO DRIVES: MOTOR FEEDBACK SYSTEMS WITH HIPERFACE DSL®



## Product description

The digital HIPERFACE DSL® interface has played a significant role in shaping drive technology over recent years. EDS/EDM35 motor feedback systems come with HIPERFACE DSL® and ensure outstanding performance for high-precision servo drives used in safety applications. Fitted with a standardized mechanical interface, they are highly flexible, particularly when used in conjunction with EES/EEM37 motor feedback systems.

EDS/EDM35 systems have a newly developed optical scanning system with dual-channel scanning and are highly resistant to shocks and vibrations. Features such as safe singleturn absolute positioning and electronic type labels EDS/EDM35 make them the ideal solution for a wide range of applications, for example in the packaging and machine tool industries.

## At a glance

- Optical motor feedback system with HIPERFACE DSL®
- Up to 24-bit resolution per revolution and 4,096 revolutions with the multi-turn system
- Certified according to SIL2 and PL d
- Status monitoring and mission time histogram; temperature, speed, and revolution data are stored throughout the service life of the device

## Your benefits

- A single model with different performance levels allows system suppliers to implement a variety of applications using only one type of encoder
- EDS/EDM35 motor feedback systems are ideal for use in high-precision, dynamic applications
- The 13-bit safe absolute singleturn resolution meets the requirements of tomorrow's safety servo drives

## Additional information

Fields of application . . . . .	3
Detailed technical data . . . . .	3
Type code . . . . .	5
Ordering information . . . . .	5
Dimensional drawings . . . . .	6
Attachment specifications . . . . .	6
PIN assignment . . . . .	7
Technical Description . . . . .	8
Diagrams . . . . .	8
Supported resources for HIPERFACE DSL® . . . . .	8
Supported access levels . . . . .	10
Overview of warnings and fault indications . . . . .	10
Recommended accessories . . . . .	11

→ [www.sick.com/EDS\\_EDM35](http://www.sick.com/EDS_EDM35)

For more information, simply enter the link or scan the QR code and get direct access to technical data, CAD design models, operating instructions, software, application examples, and much more.



## Fields of application

- Packaging industry
- Machine tools

## Detailed technical data

### Performance

	Absolute Singleturn 20 bit	Absolute Singleturn 24 bit	Absolute Multiturn 20 bit	Absolute Multiturn 24 bit
<b>Resolution per revolution</b>	20 bit	24 bit	20 bit	24 bit
<b>Number of the absolute ascertainable revolutions</b>	1		4,096	
<b>Signal noise (<math>\sigma</math>)</b>	$\pm 3''^{1)}$	$\pm 1''^{1)}$	$\pm 3''^{1)}$	$\pm 1''^{1)}$
<b>Signal accuracy</b>	$\pm 50''^{2)}$	$\pm 25''^{2)}$	$\pm 50''^{2)}$	$\pm 25''^{2)}$
<b>Speed when switching on/resetting the motor feedback system</b>	$\leq 6,000 \text{ min}^{-1}$			
<b>Available memory area</b>	8,192 Byte			

<sup>1)</sup> Repeatability standard deviation in accordance with DIN 1319-1:1995.

<sup>2)</sup> In accordance with DIN ISO 1319-1, position of the upper and lower error limit depends on the installation situation, specified value refers to a symmetrical position, i.e. deviation in upper and lower direction is the same.

### Interfaces

<b>Code sequence</b>	Increasing, when turning the shaft For clockwise rotation, looking in direction "A" (see dimensional drawing)
<b>Communication interface</b>	HIPERFACE DSL®
<b>Initialization time</b>	$\leq 500 \text{ ms}^{1)}$
<b>Measurement external temperature resistance</b>	32-bit value, without prefix (1 $\Omega$ ) 0 ... 209.600 $\Omega$ <sup>2)</sup>

<sup>1)</sup> From reaching a permitted operating voltage.

<sup>2)</sup> Without sensor tolerance; at  $-40 \text{ }^\circ\text{C} \dots +160 \text{ }^\circ\text{C}$ : NTC +2K; PTC+3K (KTY84-130/PT1000). For additional conversion function of PT1000 to KTY84/130, see technical description.

### Electrical data

	For integration Absolute Singleturn	For integration Absolute Multiturn
<b>Connection type</b>	Male connector, 4-pin	Male connector, 4-pin Male connector, 8-pin
<b>Supply voltage</b>	7 V ... 12 V	
<b>Warm-up time voltage ramp</b>	Max. 180 ms <sup>1)</sup>	
<b>Power consumption</b>	$\leq 150 \text{ mA}^{2)}$	
<b>Combinable with sHub®</b>	-	- / ✓

<sup>1)</sup> Duration of voltage ramp between 0 and 7.0 V.

<sup>2)</sup> Current rating applies when using interface circuit suggestions as shown in HIPERFACE DSL® manual (8017595).

### Mechanical data

	Absolute Singleturn 20 bit	Absolute Singleturn 24 bit	Absolute Multiturn 20 bit	Absolute Multiturn 24 bit
<b>Shaft version</b>	Tapered shaft			
<b>Dimensions</b>	See dimensional drawing			
<b>Weight</b>	$\leq 100 \text{ g}$			
<b>Moment of inertia of the rotor</b>	5 gcm <sup>2</sup>			

<sup>1)</sup> Temperature expansion, mechanical attachment.

<sup>2)</sup> For SIL2 version.

	Absolute Singleturn 20 bit	Absolute Singleturn 24 bit	Absolute Multiturn 20 bit	Absolute Multiturn 24 bit
Operating speed	≤ 12,000 min <sup>-1</sup>		≤ 9,000 min <sup>-1</sup>	
Angular acceleration	≤ 250,000 rad/s <sup>2</sup>			
Start up torque	≤ 0.6 Ncm, +20 °C			
Permissible movement of the drive element, static	± 1 mm axial <sup>1)</sup>			
Permissible movement of the drive element, dynamic	± 0.1 mm radial ± 0.025 mm radial <sup>2)</sup>			
Life of ball bearings	50,000 h at 6,000 min <sup>-1</sup> (at a flange temperature of 70 °C)			

<sup>1)</sup> Temperature expansion, mechanical attachment.

<sup>2)</sup> For SIL2 version.

### Ambient data

Operating temperature range	-40 °C ... +115 °C <sup>1)</sup>
Storage temperature range	-40 °C ... +125 °C, without package
Relative humidity/condensation	90 %, Condensation not permitted
Resistance to shocks	100 g, 6 ms (according to EN 60068-2-27)
Frequency range of resistance to vibrations	50 g, 10 Hz ... 2,000 Hz (according to EN 60068-2-6)
EMC	According to EN 61000-6-2, EN 61000-6-4 and IEC 61326-3 <sup>2)</sup> According to EN 61000-6-2: 2016, EN 61000-6-4: 2006, IEC 6100-6-7: 2014 <sup>2)</sup>
Enclosure rating	IP40, When cover is closed and mating connector is attached (acc. to EN 60529-1)

<sup>1)</sup> Given typical thermal connection between motor flange and encoder stator coupling. The max. internal sensor temperature may not exceed 125 °C.

<sup>2)</sup> According to the listed standards, EMC is guaranteed if the motor feedback system with mating connector inserted is connected to the central grounding point of the motor controller via a cable shield. If other shielding concepts are used, users must perform their own tests. Class A device.

### Safety-related parameters

Safety integrity level	SIL2 (IEC 61508), SILCL3 (IEC 62061) <sup>1)</sup>
Category	3 (EN ISO 13849-1:2015)
Systematic suitability	SC 3 (IEC61508)
Test rate	24 h
Maximum demand rate	216 µs
Performance level	PL d (EN ISO 13849-1:2015)
Basis for safety function	Safe singleturn absolute position
Safety-related resolution	13 bits
Maximum difference between Safe Position 1 and Safe Position 2	3 Increments
PFH <sub>D</sub> : Probability of dangerous failure per hour	31.0 x 10 <sup>-9</sup> <sup>2)</sup>
T <sub>M</sub> (mission time)	20 years
Safety-related accuracy	0.135° <sup>3)</sup>

<sup>1)</sup> For more detailed information on the exact configuration of your machine/unit, please consult your relevant SICK branch office.

<sup>2)</sup> At 60 °C ambient temperature.

<sup>3)</sup> The safety-related accuracy specifies the maximum position error limit with which the safety functions can be supported. This results from the safety-related resolution: (360° / 13 bit = 0.045°). The accuracy to be used for project planning results from the maximum difference between Safe Position 1 and Safe Position 2. Thus the following relationship exists (safety-related accuracy = number of increments difference between Safe Position 1 and Safe Position 2 \* 0.045).

## Type code

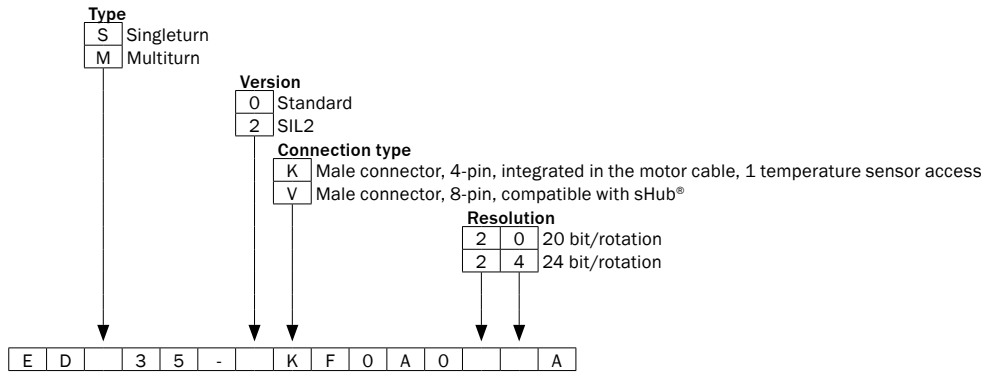

## Ordering information

### Absolute Singleturn

- **Shaft version:** tapered shaft
- **Type:** for integration
- **Communication interface:** HIPERFACE DSL®

Type	Part no.
EDS35-0KF0A020A	1090708
EDS35-0KF0A024A	1090732

- **Shaft version:** tapered shaft
- **Type:** for integration
- **Safety system:** ✓
- **Communication interface:** HIPERFACE DSL®

Type	Part no.
EDS35-2KF0A020A	1090710
EDS35-2KF0A024A	1090734

### Absolute Multiturn

- **Shaft version:** tapered shaft
- **Type:** for integration
- **Communication interface:** HIPERFACE DSL®

Necessary for connection to sHub®	Type	Part no.
✓	EDM35-0VF0A024A	1106846
-	EDM35-0KF0A020A	1090709
-	EDM35-0KF0A024A	1090733

- **Shaft version:** tapered shaft
- **Type:** for integration
- **Safety system:** ✓
- **Communication interface:** HIPERFACE DSL®

Necessary for connection to sHub®	Type	Part no.
✓	EDM35-2VF0A024A	1106851
-	EDM35-2KF0A020A	1090711
-	EDM35-2KF0A024A	1090735

Dimensional drawings (Dimensions in mm (inch))

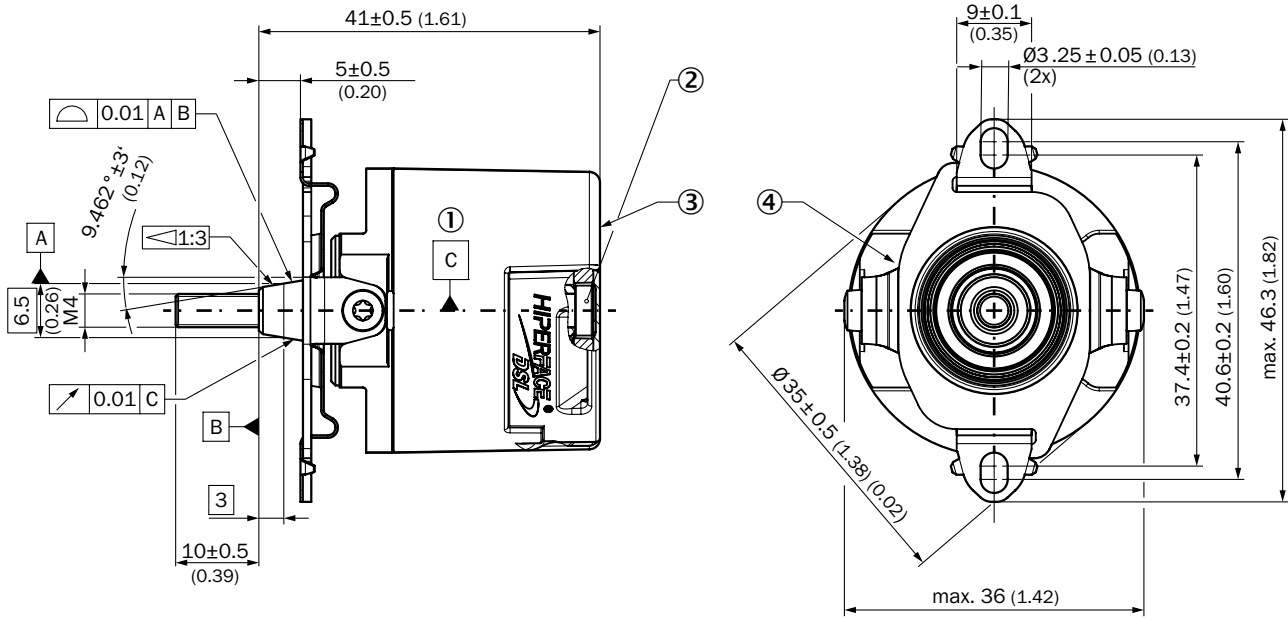

- ① Bearing of the encoder shaft
- ② Torx 15 cylinder screw
- ③ Measuring point for vibrations
- ④ Measuring point for operating temperature

Attachment specifications

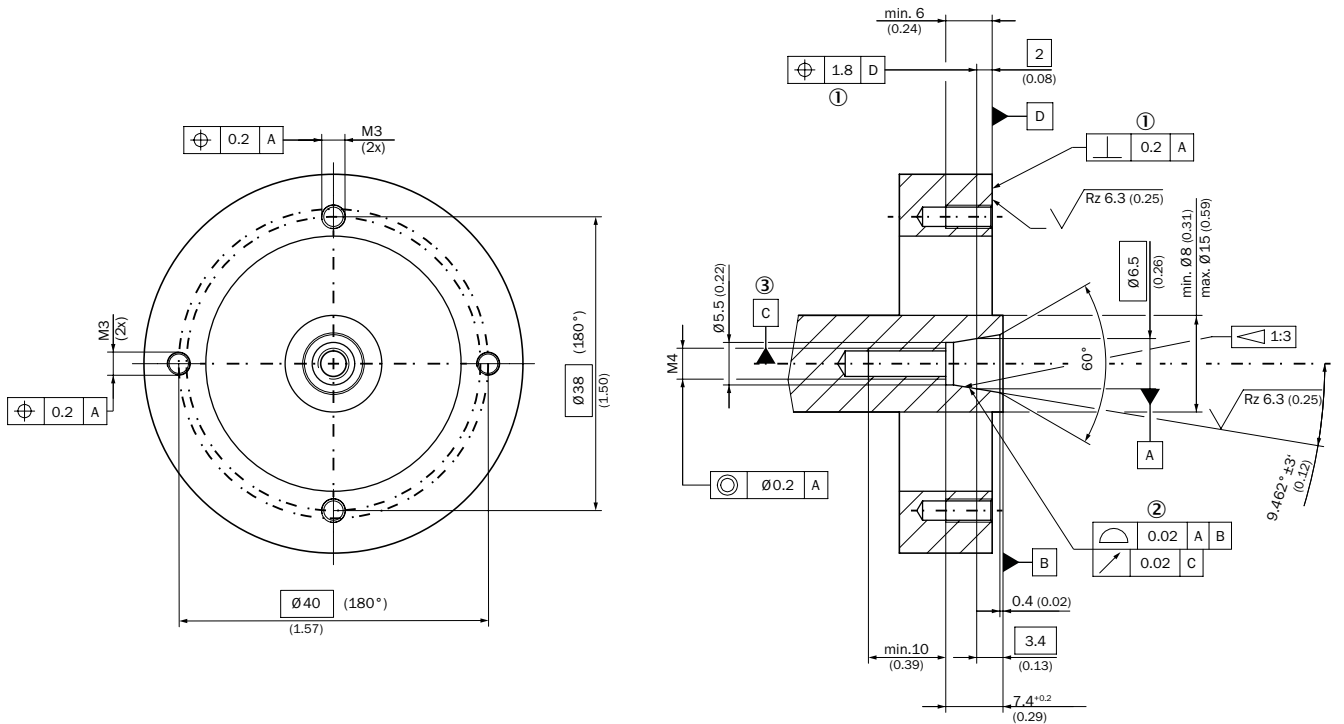

- ① Permanently
- ② Dynamic
- ③ Bearing of the drive shaft

### PIN assignment

#### Supply / Communication pin assignment

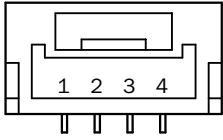

K connection type  
Integrated in motor cable = K

PIN	Signal	Explanation
1		Not connected - no function
2	+U <sub>s</sub> /DSL+	Supply 7 V ... 12 V
3	GND/DSL-	Ground connection
4		Not connected - no function
Recommended outer diameter of set of stranded wires: 2.8 mm ±0.3 mm		
Recommended mating connector: JST (GHR-04V-S)		

#### PIN assignment temperature sensor

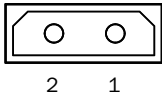

K connection type  
Integrated in motor cable = K

PIN	Signal	Explanation
1	T+	Thermistor connection
1	T-	Thermistor connection (to ground)
Recommended outer diameter of set of stranded wires: 2.2 mm ± 0.1 mm		
Recommended mating connector: Harwin M80-8990205		

#### Supply / Communication pin assignment

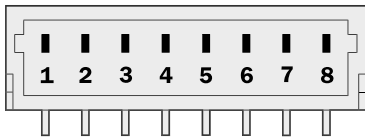

V connection type

PIN	Signal	Explanation
1	+U <sub>s</sub>	Supply
2	GND	Ground connection
3	DSL-	DSL negative
4	DSL+	DSL positive
5	RxD+	
6	RxD-	
7	TxD-	
8	TxD+	
Recommended mating connector: JST (GHR-08V-S)		

## Technical Description

Notes on the diagrams

### KTY emulation

The KTY emulation function supports the conversion from the KTY84/130 temperature sensor to the PT1000 temperature sensor.

### Central fixing screw

The central fixing screw is not part of the delivery and must be ordered separately. See recommended accessories.

With the emulation function “ON”, a resistance value measured with the PT1000 is converted into an equivalent resistance value of the KTY84/130. The function can be switched on or off with the resource 201h, MANAGEIO. By default, the emulation function is switched off.

The coating of the fastening screw has a specific shelf life. Therefore the screw may only be used for assembly until the specified date. The central fixing screw must not be used after the expiration date.

## Diagrams

Typical inrush current (A)

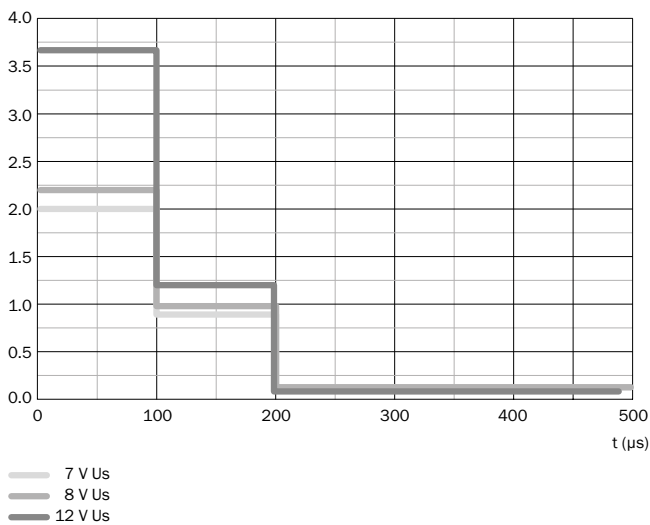

## Supported resources for HIPERFACE DSL®

Resource Index	Function	Size (max. Offset)	Read access	Write access	Time overrun [ms]	Name
000h	Root node		0	-	75	ROOT
001h	Identification note		0	-	75	IDENT
002h	Monitoring node		0	-	75	MONITOR
003h	Administration node		0	-	75	ADMIN
004h	Counter node		0	-	75	COUNTER
005h	Data storage node		0	-	75	DATA
006h	Sensor hub nodes		0	-	75	SENSHUB
080h	Type of encoder	2	0	-	120	ENCTYPE
081h	Resolution	4	0	-	120	RESOLUTN
082h	Measurement range	4	0	-	120	RANGE
083h	Type name	18	0	-	120	TYPECODE
084h	Serial number	10	0	-	120	SERIALNO
085h	Device version	20	0	-	120	FWREVNO
086h	Firmware date	8	0	-	120	FWDATE
087h	EEPROM size	2	0	-	120	EESIZE



Resource Index	Function	Size (max. Offset)	Read access	Write access	Time overrun [ms]	Name
089h	Number of steps per turn of safe channel 2	4	0	-	120	VPOS2RES
0C0h	Temperature range	4	0	-	90	TEMPRNG
0C1h	Temperature	2	0	-	70	TEMPRTUR
0C2h	LED current range <sup>1)</sup>	4	0	-	90	LEDRANGE
0C3h	LED current <sup>1)</sup>	2	0	-	70	LEDCURR
0C4h	Supply voltage range	4	0	-	90	SUPRANGE
0C5h	Supply voltage	2	0	-	70	SUPVOLT
0C6h	Rotation speed range	2	0	-	90	SPEEDRNG
0C7h	Rotation speed	2	0	-	70	SPEED
0C8h	Acceleration range	2	0	-	90	ACCRANGE
0CBh	Lifetime	8 for non-SIL 12 for SIL2	0	-	70	LIFETIME
0CCh	Error log <sup>1)</sup>	8	0	-	100	ERRORLOG
0CDh	Usage histogram	4	0	-	70	HISTOGRM
0D5h	Filters error log entries	2	0	4	100	ERRLOGFI
100h	Reset/shut down	0	-	0	240	RESET
101h	Set position	8	0	4	200	SETPOS
104h	Set access level	8	0	0	70	SETACCESS
105h	Change access key	8	-	0	90	CHNGEKEY
107h	User-defined warnings	8	0	2	90	UWARNING
108h	Factory setting	8	-	2	1,100	FACRESET
10Ah	Position filter setting	4	0	3	90	POSFILT
111h	User-defined encoder index and incorporation function	2	0	3	90	ENCINDEX
11Dh	Features <sup>2)</sup>	2	0	-	90	FEATURES
11Fh	Bootloader	8	4	4	200	BOOTLOAD
120h	Read counter	4	0	-	90	READCNT
121h	Increment counter	0	-	0	90	INCCOUNT
122h	Reset counter	0	-	2	90	RESETCNT
130h	Load file	8	-	0	900	LOADFILE
131h	Read/write file	File size	User-defined	User-defined	260	RWFILE
132h	File status	4	0	-	70	FILESTAT
133h	Create/delete/change file	8	-	User-defined	1,000	MAKEFILE
134h	Directory	8	0	-	150	DIR
136h	Set or read back status of user file backup	2	0	2	90	FILEBACK
200h	Access simple I/O	4	0	0	70	ACCESSIO
201h	Manage simple I/O	4	0	2	90	MANAGEIO
202h	Identify simple I/O	8	0	-	70	IDENTIO

<sup>1)</sup> LED-current measurement with 0,1 mA-steps, Error Log contains LED-information at the time of error

<sup>2)</sup> Only valid vor connection type V

## Supported access levels

Access level	User	Standard access key
0	Execute (default setting)	- (no key required)
1	Operator	1111 (31 31 31 31h)
2	Maintenance	2222 (32 32 32 32h)
3	Authorized client	3333 (33 33 33 33h)
4	User service	4444 (34 34 34 34h)

## Overview of warnings and fault indications

Error type	Error register	Error bit	Description
Position (incremental)	40h	0	A Protocol reset was executed
	40h	1	Acceleration overflow, invalid position
	40h	2	Test running
	40h	4	Internal error in angular tracking, invalid position
	40h	5	Internal error in vector length, invalid position
	40h	6	Internal error in position counter, invalid position
	40h	7	Internal error in position synchronization, invalid position
Position (absolute)	41h	0	Error in absolute position in a rotation
	41h	1	Multiturn amplitude error
	41h	2	Multiturn sync error
	41h	3	Multiturn vector length error
	41h	4	Position cross check error
Initialization	42h	0	Switch-on self-test undertaken (only safety versions)
	42h	1	Warning safety parameter: error could be rectified (only safety variants)
	42h	2	Error safety parameter: error cannot be rectified (only safety variants)
	42h	3	Standard parameter error
	42h	4	Internal communications error 1
	42h	5	Internal communications error 2
	42h	6	Internal general error
Checking	43h	0	Critical temperature
	43h	1	Critical LED current
	43h	2	Critical supply voltage
	43h	3	Critical speed
	43h	5	Counter overflow
	43h	6	Internal monitoring error
Access to resources	44h	0	Invalid argument given during resource access procedure
	44h	1	Resource access refused due to incorrect access level
	44h	2	Internal error during resource access
	44h	3	Error when accessing a user file

Error type	Error register	Error bit	Description
User-defined warnings	47h	0	User-defined warning 0
	47h	1	User-defined warning 1
	47h	2	User-defined warning 2
	47h	3	User-defined warning 3

## Recommended accessories

### Mounting systems

#### Nuts and screws



#### Screws

Figure	Brief description	Type	Part no.
	500 pieces, Screws with Precote 85-8 coating; M4*48 (4093779)	BEF-MK-S09	2103244
	100 pieces, Screws with Precote 85-8 coating; M4*48 (4093779)	BEF-MK-S10	2103272
	10 pieces, Screws with Precote 85-8 coating; M4*48 (4093779)	BEF-MK-S11	2103274

### Connection systems

#### Plug connectors and cables

#### Connecting cables

Figure	Brief description	Length of cable	Type	Part no.
	Head A: female connector, stranded wire, 4-pin, straight Head B: Flying leads Cable: HIPERFACE DSL®, unshielded	0.2 m	DOL-0B02-G0M2XC2	2079920
	Head A: female connector, stranded wire, 4-pin, straight Head B: Flying leads Cable: HIPERFACE DSL®, twisted, shielded	0.36 m	DOL-0B02-G0M3AC2	2108944

Dimensional drawings → [page 11](#)

### Further accessories

#### Programming and configuration tools

Figure	Brief description	Type	Part no.
	SVip® LAN programming tool for all motor feedback systems	PGT-11-S LAN	1057324

Dimensional drawings → [page 13](#)

Dimensional drawings for accessories (Dimensions in mm (inch))

Plug connectors and cables

DOL-0B02-G0M2XC2

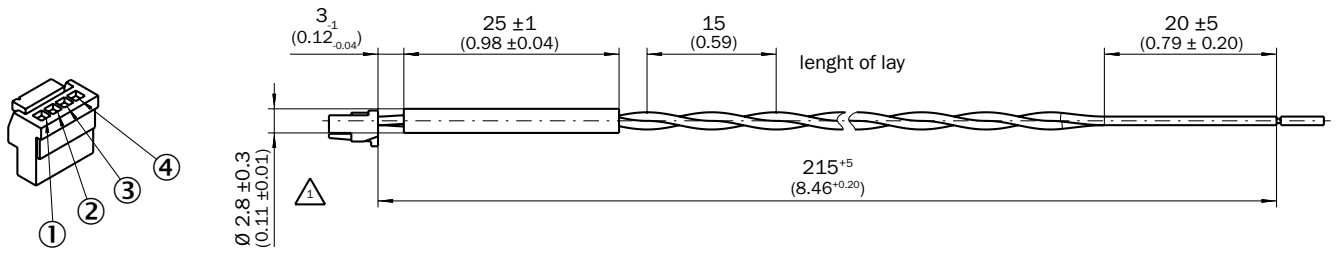

- ② Gray
- ③ Green

DOL-0B02-G0M3AC2

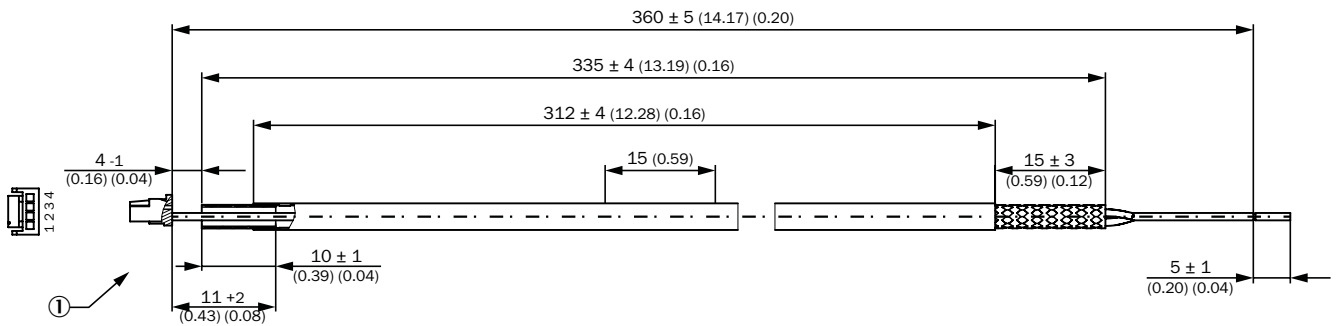

Programming and configuration tools

PGT-11-S LAN

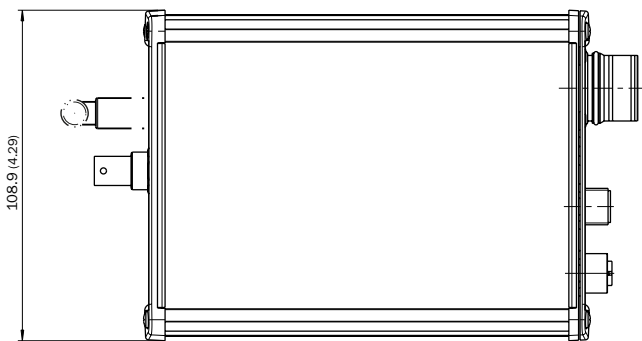
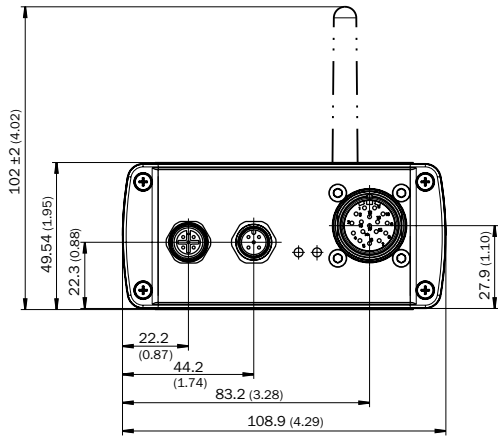
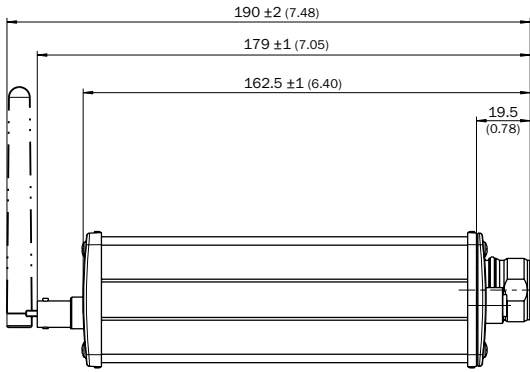

# SENSOR HUB FOR INTELLIGENT SERVO MOTORS THAT “SAYS” WHEN MAINTENANCE IS REQUIRED



## Product description

With the sHub sensor hub, servo motors can be used as a source of data for condition monitoring and predictive maintenance of the machine. The data is collected in the motor and transmitted to the control using the HIPERFACE DSL®. Monitoring occurs in real time. It is therefore possible for the maintenance

staff to react in a timely manner and intervene in machine processes, e.g. if servo motors are imbalanced. sHub provides additional sensor data such as vibration for intelligent servo drive systems, therefore increasing the efficiency and reliability of machines.

## At a glance

- Sensor hub with a maximum of 2 inputs for external sensors
- The sensor data is integrated in to the motion control system via HIPERFACE DSL®.
- Collection of vibration, temperature, speed, position and service life histogram of the servo motor (combined with EDS/EDM35)

## Your benefits

- You can implement Industry 4.0 requirements such as condition monitoring and predictive maintenance through the collection of additional sensor data in the servo motor.
- Increase the availability of your machine with reliable condition monitoring and targeted maintenance
- You can minimize the time and money needed for development thanks to the existing HIPERFACE DSL® infrastructure in servo controllers.
- The synchronous detection of position and vibration data means less computation is required in the processor.
- Additional cabling is not required.



## Additional information

Fields of application . . . . .	15
Detailed technical data . . . . .	15
Ordering information . . . . .	15
Dimensional drawings . . . . .	16
Recommended accessories . . . . .	16

→ [www.sick.com/sHub](http://www.sick.com/sHub)

For more information, simply enter the link or scan the QR code and get direct access to technical data, CAD design models, operating instructions, software, application examples, and much more.



## Fields of application

- Servo motors: Early detection of ball bearing damage and imbalances due to vibration analysis (vibration analyses done by the drive manufacturer)
- Condition monitoring of servo motors
- Smart drive technology

## Detailed technical data

### Features

Items supplied	Cable (part number: 2115196) included with delivery
----------------	---

### Performance

Measurement principle	Acceleration sensor
Measuring range	± 50 g
Bandwidth	10 kHz
Resolution	13 bit
Measuring step	24.4 mg / digit
Maximum sampling rate	32 kS / s, synchrone to the position sampling of the EDS/EDM35
Signal noise density	25 µg / √Hz

### Interfaces

Code sequence	Increasing, when turning the shaft For clockwise rotation, looking in direction "A" (see dimensional drawing)
Communication interface	HIPERFACE DSL®
Initialization time	≤ 500 ms
Measurement external temperature resistance	32-bit value, without prefix (1 Ω) 0 ... 209.600 Ω

### Electrical data

Connection type	Female connector, 8-pin
Supply voltage	7 V ... 12 V
Warm-up time voltage ramp	Max. 180 ms
Power consumption	≤ 300 mA

### Mechanical data

Weight	≤ 250 g
--------	---------

### Ambient data

Operating temperature range	-40 °C ... +115 °C
Storage temperature range	-40 °C ... +125 °C, without package
Relative humidity/condensation	90 %, Condensation not permitted
Resistance to shocks	100 g, 6 ms (according to EN 60068-2-27)
Frequency range of resistance to vibrations	50 g, 10 Hz ... 2,000 Hz (according to EN 60068-2-6)
EMC	According to EN 61000-6-2, EN 61000-6-4 and IEC 61326-3
Enclosure rating	IP40, with mating connector inserted (acc. to EN 60529-1)

## Ordering information

Type	Communication interface	Type	Part no.
For integration	HIPERFACE DSL®	SHUB10-0ZA87010	1107310

Dimensional drawings (Dimensions in mm (inch))

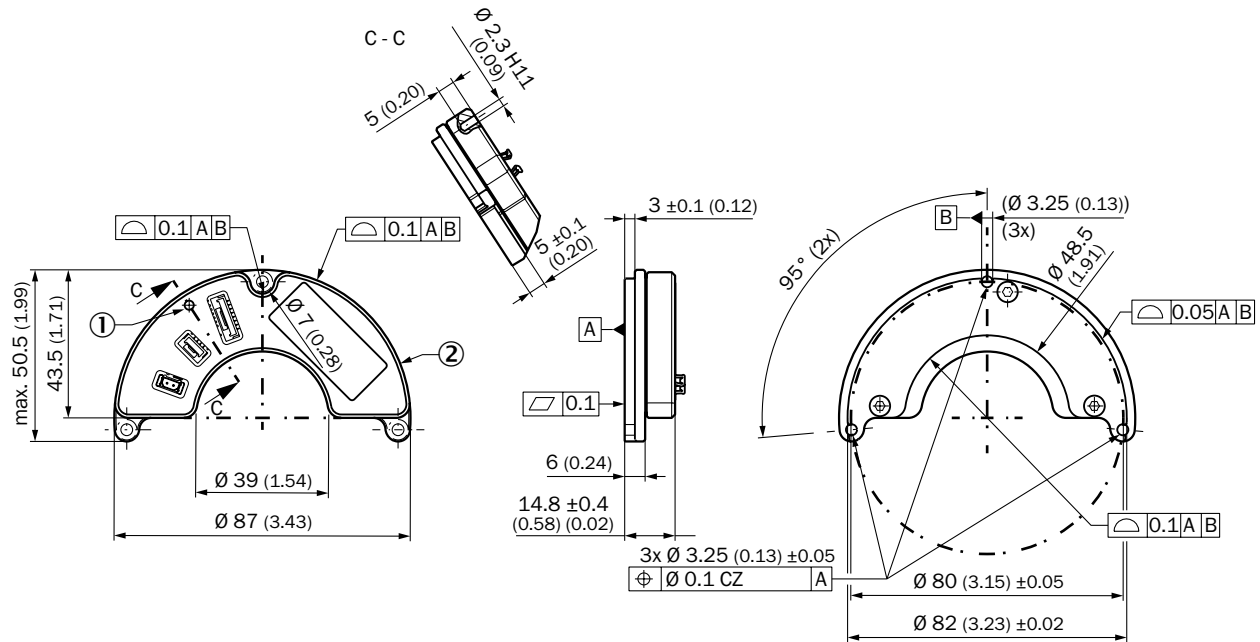

PIN assignment

Temperature sensor male connector

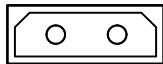

2 1

PIN	Signal
1	T+
2	T- / GND
Harwin M80-8820242	
Device pin assignment	

Recommended accessories

Connection systems

Plug connectors and cables

Connecting cables

Brief description	Length of cable	Type	Part no.
Head A: female connector, stranded wire, 8-pin, straight Head B: female connector, stranded wire, 8-pin, straight Cable: sHub®, unshielded	0.1 m	DOL-1J08-G0M1XC2	2115196







## WORKING WITH SICK IN A DIGITAL WORLD

Making your digital business environment comfortable

### Find a suitable solution in next to no time

Often we know best what we need – but not necessarily where to find it right away. SICK will support you with its in-depth expertise.

- Online product catalog – our digital flagship  
→ [www.sick.com/products](http://www.sick.com/products)
- Application Solver – the right sensor for selected applications → [www.sick.com/applicationBased](http://www.sick.com/applicationBased)
- Online configurators and selectors – exactly the right sensor for your needs

### My SICK is your personal self-service portal

My SICK is your personal self-service portal with lots of helpful information and your own individual access to the web shop. Take advantage of the wide variety of exclusive advantages on offer:

#### Your benefits

- Open around the clock
- Clear product information
- Company-specific price conditions
- Convenience during the ordering process
- Document overview
- Availability and delivery times

#### Register now:

→ [www.sick.com/myBenefits](http://www.sick.com/myBenefits)



### Get ahead with digital knowledge transfer and digital services

- Digital Customer Trainings → [www.sick.com/c/g300887](http://www.sick.com/c/g300887)
- Digital Service Catalog → [cloud.sick.com](http://cloud.sick.com)
- SICK AppPool → [apppool.cloud.sick.com](http://apppool.cloud.sick.com)

## SICK AT A GLANCE

SICK is a leading manufacturer of intelligent sensors and sensor solutions for industrial applications. With more than 10,400 employees and over 50 subsidiaries and equity investments as well as numerous agencies worldwide, SICK is always close to its customers. A unique range of products and services creates the perfect basis for controlling processes securely and efficiently, protecting individuals from accidents, and preventing damage to the environment.

SICK has extensive experience in various industries and understands their processes and requirements. With intelligent sensors, SICK delivers exactly what the customers need. In application centers in Europe, Asia, and North America, system solutions are tested and optimized in accordance with customer specifications. All this makes SICK a reliable supplier and development partner.

Comprehensive services round out the offering: SICK LifeTime Services provide support throughout the machine life cycle and ensure safety and productivity.

**That is “Sensor Intelligence.”**

### **Worldwide presence:**

Australia, Austria, Belgium, Brazil, Canada, Chile, China, Czech Republic, Denmark, Finland, France, Germany, Great Britain, Hungary, Hong Kong, India, Israel, Italy, Japan, Malaysia, Mexico, Netherlands, New Zealand, Norway, Poland, Romania, Russia, Singapore, Slovakia, Slovenia, South Africa, South Korea, Spain, Sweden, Switzerland, Taiwan, Thailand, Turkey, United Arab Emirates, USA, Vietnam.

Detailed addresses and further locations → [www.sick.com](https://www.sick.com)