

7556

Digital Resistance Meter

USER'S MANUAL

Product Registration

Thank you for purchasing YOKOGAWA products.

YOKOGAWA provides registered users with a variety of information and services. Please allow us to serve you best by completing the product registration form accessible from our website.

<http://tmi.yokogawa.com/>

Thank you for purchasing the YOKOGAWA Digital Resistance Meter 755601/755611. This User's Manual contains useful information about the functions, operating procedures, and handling precautions of the instrument. To ensure correct use, please read this manual thoroughly before operation. Keep this manual in a safe place for quick reference in the event a question arises.

Notes

- The contents of this manual are subject to change without prior notice as a result of continuing improvements to the instrument's performance and functions. The figures given in this manual may differ from the actual screen.
- Every effort has been made in the preparation of this manual to ensure the accuracy of its contents. However, should you have any questions or find any errors, please contact your nearest YOKOGAWA dealer.
- Copying or reproducing all or any part of the contents of this manual without YOKOGAWA's permission is strictly prohibited.

Trademarks

- MS-DOS is a registered trademark of Microsoft Corporation.
- PostScript is a registered trademark of Adobe Systems Incorporated.
- Other company and product names are trademarks or registered trademarks of their respective holders.

Revisions

1st edition: July 1999
2nd edition: September 2013
3rd edition: May 2014
4th edition: October 2017

Checking the Contents of the Package

Unpack the box and check the contents before operating the instrument. If some of the contents are not correct or missing or if there is physical damage, contact the dealer from which you purchased them.

7556 Main Unit

Check that the model name and suffix code given on the name plate on the side panel match those on the order. When contacting the dealer from which you purchased the instrument, please quote the instrument No.

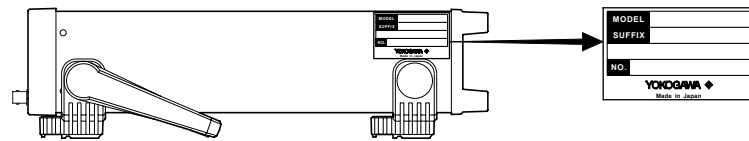

MODEL and SUFFIX codes

Model Name	Suffix Code	Specifications
755601		0.01% resolution
755611		0.001% resolution
Power supply	-1	100 VAC
	-4	120 VAC
	-6	220 VAC
	-8	240 VAC
Power cord ¹	-D	UL/CSA Standards Power Cord (Part No.: A1006WD)
	-F	VDE Standard Power Cord (Part No.: A1009WD)
	-Q	BS Standard Power Cord (Part No.: A1054WD)
	-R	SAA Standard Power Cord (Part No.: A1024WD)
	-H	GB Standard Power Cord (complies with the CCC) (Part No.: A1064WD)
Options	/C1	GP-IB interface
	/C2	Centronics interface
	/C3	GP-IB & Centronics interface

¹ Make sure that the attached power cord meets the designated standards of the country and area that you are using it in.

NO. (Instrument No.)

When contacting the dealer from which you purchased the instrument, please quote the instrument No.

Standard Accessories

The following standard accessories are supplied with the instrument. Check that all items are present and that they are undamaged.

1. Power cord (one of the following power cords is supplied according to the instrument's suffix codes)¹

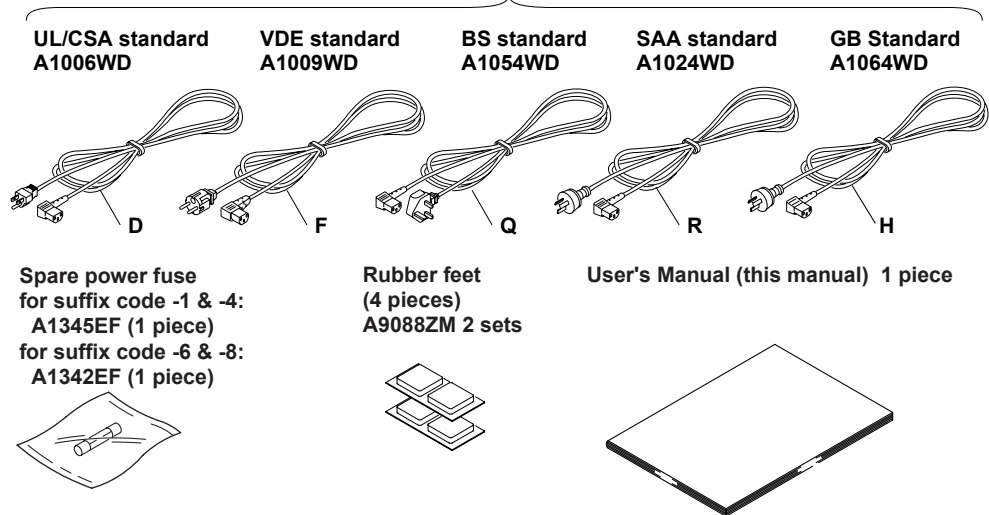

¹ Make sure that the attached power cord meets the designated standards of the country and area that you are using it in.

Note

- We recommend you keep the packing box. The box is useful when you need to transport the instrument.
- For information regarding the fuse ratings, see section 11.5, "Replacing the Power Fuse."

Safety Precautions

This product is designed to be used by a person with specialized knowledge. This instrument is designed for indoor use only. The following general safety precautions must be observed during all phases of operation. If the instrument is used in a manner not specified in this manual, the protection provided by the instrument may be impaired. This manual is an essential part of the product; keep it in a safe place for future reference. YOKOGAWA assumes no liability for the customer's failure to comply with these requirements.

The following symbols are used on this instrument.



"Handle with care." To avoid injury, death of personnel or damage to the instrument, the operator must refer to the explanation in the User's Manual or Service Manual.



AC



ON (power)



OFF (power)

Make sure to comply with the following safety precautions. Not complying might result in injury, death of personnel.

WARNING

Use the Instrument Only for Its Intended Purpose

This instrument is a resistance measuring device. Do not use this instrument for anything other than as a resistance measuring device.

Check the Physical Appearance

Do not use the instrument if there is a problem with its physical appearance.

Power Supply

Ensure that the source voltage matches the voltage of the power supply before turning ON the power.

Power Cord and Plug

- To prevent an electric shock or fire, be sure to use the power cord supplied by YOKOGAWA. The main power plug must be plugged into an outlet with a protective grounding terminal. Do not invalidate protection by using an extension cord without protective grounding. Additionally, do not use the power cord supplied with this instrument with another instrument.
- Do not use the power cord in a bundled condition.
- If you use a power plug with foreign substance on it, insulation may be compromised by humidity or other factors and may cause a fire. Clean the power plug regularly.

Protective Grounding

Make sure to connect the protective grounding to prevent electric shock before turning ON the power.

Necessity of Protective Grounding

Never cut off the internal or external protective grounding wire or disconnect the wiring of the protective grounding terminal. Doing so poses a potential shock hazard.

Do Not Use When the Protection Functions Are Defective

Before using this instrument, check that the protection functions, such as the protective grounding and fuse, are working properly. If you suspect a defect, do not use the instrument.

Do Not Remove the Covers or Disassemble or Alter the Instrument

Only qualified YOKOGAWA personnel may remove the covers and disassemble or alter the instrument. The inside of the instrument is dangerous because parts of it have high voltages.

External Connection

Connect the protective grounding before connecting to the item under measurement or external control circuit. If you need to touch the circuit, turn off its power and make sure that there are no voltages being generated.

Measurement Category

The measurement category of this instrument signal input terminals is Other (O). Do not use it to measure the main power supply or for Measurement Categories II, III, and IV.

Install or Use the Instrument in Appropriate Locations

- This instrument is designed to be used indoors. Do not install or use it outdoors.
- Install the instrument so that you can immediately remove the power cord if an abnormal or dangerous condition occurs.

CAUTION

Operating Environment Limitations

This product is a Class A (for industrial environments) product. Operation of this product in a residential area may cause radio interference in which case the user will be required to correct the interference.

Waste Electrical and Electronic Equipment



Waste Electrical and Electronic Equipment (WEEE), Directive

(This directive is valid only in the EU.)

This product complies with the WEEE directive marking requirement. This marking indicates that you must not discard this electrical/electronic product in domestic household waste.

Product Category

With reference to the equipment types in the WEEE directive, this product is classified as a "Monitoring and control instruments" product.

When disposing of products in the EU, contact your local Yokogawa Europe B.V. office. Do not dispose in domestic household waste.

EU Battery Directive



EU Battery Directive

(This directive is valid only in the EU.)

Batteries are included in this product. This marking indicates they shall be sorted out and collected as ordained in the EU battery directive.

Battery type: Lithium battery

You cannot replace batteries by yourself. When you need to replace batteries, contact your local Yokogawa Europe B.V. office.

How to Use this Manual

Structure of the Manual

This User's Manual consists of the following 12 chapters, and an index.

Chapter	Title	Description
1	Functions	Describes the measurement principles and functions of the instrument. Operating procedures are not given in this chapter. However, reading this chapter will help you understand the operating procedures given in the chapters that follow.
2	Names and Uses of Parts	Describes the names and uses of each part of the instrument. For keys, references are given to pages in the manual where operating procedures are explained.
3	Before Starting Measurements	Describes precautions on use, how to install the instrument, how to connect the power supply, turn ON/OFF the power switch, and other operations.
4	Setting the Measurement Conditions	Describes how to set the measurement conditions such as measurement range and limits.
5	Making Measurements	Describes how to make measurements.
6	Other Functions	Describes how to save and recall measured data and how to print out the data.
7	Using the Handler Interface	Describes the handler interface specifications, how to setup the handler interface, and the timing chart.
8	Using the Serial (RS-232) Interface	Describes how to control this instrument from a controller (such as a PC) and how to retrieve measured data from the instrument via the serial (RS-232) interface.
9	Using the GP-IB Interface	Describes how to control this instrument from a controller (such as a PC) and how to retrieve measured data from the instrument via the GP-IB interface.
10	Using Communication Commands	Describes communication commands and sample programs.
11	Error Messages and Maintenance, and Inspection	Describes the possible causes of problems and their appropriate corrective measures. Describes the messages that are displayed on the screen. Describes how to perform self-tests.
12	Specifications	The specifications of the instrument are given on tables.
	Index	Gives an Index.

Conventions Used in this Manual

Symbols

The following symbols are used in this manual.



Affixed to the instrument. Indicates danger to personnel or instrument and the operator must refer to the User's Manual. The symbol is used in the User's Manual to indicate the reference.

WARNING

Describes precautions that should be observed to prevent injury or death to the user.

CAUTION

Describes precautions that should be observed to prevent minor or moderate injury, or damage to the instrument.

Note

Provides important information for the proper operation of the instrument.

Characters displayed on the seven-segment LED

Because this instrument uses a seven-segment LED to display alphanumeric characters, some of the characters are displayed using special characters. For details, see section 1.3, "Digital Numbers and Characters and A List of Menus" (page 1-4).

Symbols used on pages in which operating procedures are given

In chapters 3 through 9, on pages where operating procedures are given, the following symbols are used to classify a description.

Keys

Indicates the keys and indicators related to the setting.

Procedure

Describes the procedures using a flow diagram. For details on how to read the flow diagram, see the example given on the next page. The procedures are based on the premise that the user is carrying them out for the first time. Therefore, in some cases, you may not have to follow all the steps.

Explanation

Describes the details of the settings and the restrictions that exist with the operating procedure. A detailed description of the function is not provided in this section. See chapter 1 for a detailed description of the functions.

A Procedure Example

1. Pressing the SHIFT key then the MΩ key displays the contact check selection menu.
2. Press the REF or LIMIT key until the desired item appears on the screen.
3. Press the ENTER key to confirm the selection.
4. If you selected bEF or AFt, enter the contact check level using the numerical keys. Then, press the ENTER key to confirm.

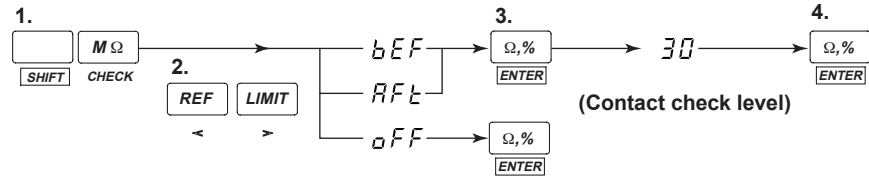

Symbols Used in the Syntax

The following table indicates symbols that are used in the syntax mainly in Chapter 10. These symbols are referred to as BNF (Backus-Naur Form) symbols. For details, see pages 10-5 and 10-6.

Symbol	Meaning	Example	User Input Example
<>	Defined value	:PANel:RECa11{<NRf>}<NRf>=0 to 9	→:PANEL:RECALL 3
{}	Select a value from	{}:MTIME{NORMa1 FAST HSPEED}	→:MTIME FAST
	Exclusive OR		
[]	Can be omitted	:CHECK[:MODE]BEFore	→:CHECK:BEFORE

Contents

Checking the Contents of the Package	ii
Safety Precautions	iv
Waste Electrical and Electronic Equipment	vi
EU Battery Directive	vi
How to Use this Manual	vii
Chapter 1 Functions	
1.1 Block Diagram	1-1
1.2 Functions	1-2
1.3 Digital Numbers and Characters and A List of Menus	1-4
1.4 A List of Initial Values	1-7
Chapter 2 Names and Uses of Parts	
2.1 Names of Parts	2-1
2.2 Keys and Error Displays	2-2
Chapter 3 Before Starting Measurements	
3.1 Precautions on the Use of the instrument	3-1
3.2 Installing the Instrument	3-2
⚠ 3.3 Connecting the Power Cord	3-3
⚠ 3.4 Wiring	3-5
Chapter 4 Setting the Measurement Conditions	
4.1 Switching the Limit Mode	4-1
4.2 Changing the Range (Reference)	4-2
4.3 Using the Comparator Function	4-4
4.4 Using the Contact Check Function	4-7
4.5 Setting the Measurement Time	4-8
⚠ 4.6 Using the Trigger Function	4-9
Chapter 5 Making Measurements	
5.1 Setting the Measurement Mode	5-1
5.2 Switching between Deviation (%) and Absolute (R) Displays	5-3
Chapter 6 Other Functions	
6.1 Store/Recall Measured Data	6-1
⚠ 6.2 Printing Data	6-3
6.3 Initializing the Setup Information	6-7
Chapter 7 Using the Handler Interface	
7.1 Handler Interface Functions and Specifications	7-1
7.2 Setting the Pulse Width of the EOM Signal	7-4
7.3 Timing Chart	7-5

Chapter 8 Using the Serial (RS-232) Interface

8.1	Serial (RS-232) Interface Functions and Specifications	8-1
8.2	Connecting the Serial (RS-232) Interface Cable	8-2
8.3	Handshaking	8-4
8.4	Data Format	8-6
8.5	Serial Communication Settings	8-7

Chapter 9 Using the GP-IB Interface

9.1	GP-IB Interface Functions and Specifications	9-1
9.2	Connecting the Interface Cable	9-3
9.3	Responses to Interface Messages	9-4
9.4	Switching to the Addressable Mode	9-6
9.5	Switching to the Talk-only Mode	9-8

Chapter 10 Communication Commands

10.1	Before Programming	10-1
10.1.1	Messages	10-1
10.1.2	Commands	10-3
10.1.3	Responses	10-4
10.1.4	Data	10-5
10.1.5	Synchronization with the Controller	10-7
10.1.6	Programming of Various Functions	10-9
10.2	Commands	10-13
10.2.1	A List of Commands	10-13
10.2.2	CHECK(contact CHECK) Group	10-15
10.2.3	COMMunicate Group	10-16
10.2.5	HANDler Group	10-18
10.2.4	DISPlay Group	10-18
10.2.6	HEADer Group	10-19
10.2.7	LIMit Group	10-20
10.2.8	MEASure Group	10-22
10.2.9	MTIME(Meas TIME) Group	10-23
10.2.10	PANel Group	10-23
10.2.11	PRINt Group (Option)	10-24
10.2.12	READ Group	10-25
10.2.13	RECall Group	10-26
10.2.14	SELFtest Group	10-28
10.2.15	STATus Group	10-29
10.2.16	STORe Group	10-30
10.2.17	TRIGger Group	10-32
10.2.18	Common Command Group	10-33
10.3	Status Report	10-36
10.3.1	About the Status Report	10-36
10.3.2	Status Byte	10-37
10.3.3	Standard event register	10-38
10.3.4	Extended Event Register	10-39
10.3.5	Output Queue and Error Queue	10-40
10.4	ASCII Character Codes	10-41
10.5	About the IEEE.488.2-1992 Standard	10-42

1

2

3

4

5

6

7

8

9

10

11

12

Index

Chapter 11 Error Messages, Maintenance, and Inspection

11.1 Troubleshooting 11-1
11.2 Messages and Corrective Actions 11-2
11.3 Self Test 11-5
11.4 Adjustments 11-7
11.5 Replacing the Power Fuse 11-12

Chapter 12 Specifications

12.1 Input Specifications 12-1
12.2 Trigger Specifications 12-3
12.3 Measurement Time Specifications 12-3
12.4 Contact Check Specifications 12-4
12.5 Comparator Specifications 12-4
12.6 Other Specifications 12-5
12.7 Handler Interface Specifications 12-5
12.8 Communication Specifications 12-6
12.9 General Specifications 12-6
12.10 External Dimensions 12-8

Index

1.1 Block Diagram

Block Diagram

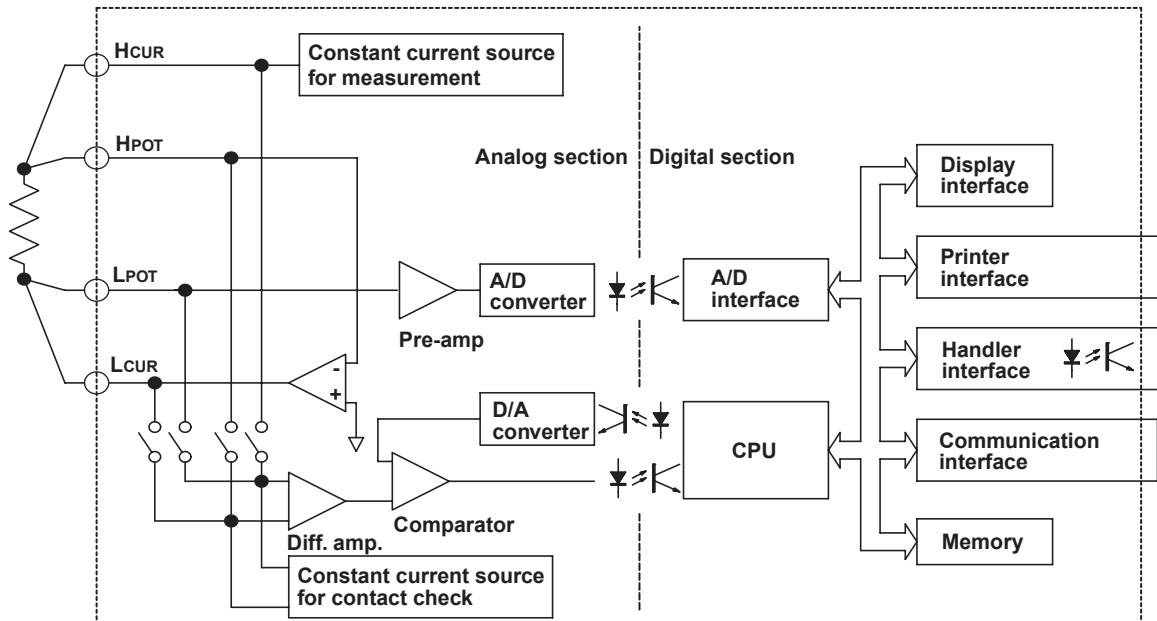

Measurement Principle

A constant current is fed through the resistor under measurement from the H_{CUR} terminal to the L_{CUR} terminal, and the voltage difference between the H_{POT} and L_{POT} terminals is measured. Because the electric potential at the H_{POT} terminal is controlled so that it is equal to the circuit's common electric potential, the resistance can be determined by dividing the voltage at the L_{POT} terminal by the current.

In the contact check that is performed before or after the measurement, a constant current is fed from the H_{CUR} terminal to the H_{POT} terminal and from the L_{POT} terminal to the L_{CUR} terminal. The voltage that appears across these terminals is compared with the reference voltage that was set by the D/A converter to check the connection to the resistor under measurement.

Since the analog section is insulated from the digital section (electric potential of the case), the circuit is robust against noise, resulting in a stable measurement. In addition, the handler interface is also insulated from the case in order to minimize noise influence.

1.2 Functions

Comparator Function

Determines whether or not the measured result is within the comparison range set arbitrarily by the user. HI, IN, or LO mark is turned ON to indicate the comparator result. The result is also output via the handler interface.

Contact Check Function

Determines whether or not the item under measurement is properly connected to the measurement input terminal, and the result is output via the handler interface. If an error is detected, “- n.c - (no contact)” is displayed.

Trigger Function

Trigger Mode

The instrument has the following three types of trigger modes:

- External trigger: Makes a measurement when the instrument detects a rising or falling edge of a signal that is applied to the external trigger input terminal or the number 8 pin (EXT TRIG) of the handler interface.
- Manual trigger: Makes a measurement when the TRIG key on the front panel is pressed or whenever a trigger is activated via the communication interface.
- Internal trigger: Makes measurements at intervals which depend on the specified measurement time (auto sampling).

Trigger Delay

The measurement can then be started the specified time after the trigger occurrence. A trigger delay is enabled when the trigger mode is set to external trigger or manual trigger.

Communication Function

Handler and serial (RS-232) interfaces come standard with the instrument. A GP-IB interface is also available as an option.

Printout Function

By using the optional Centronics interface, data stored in the memory, statistics collected from those data, and other information can be printed to an external printer.

Handler Interface Function

The handler interface is used to output comparator results, contact check results, index signals, and various other signals.

For the specifications of each pin, see section 12.7 “Handler Interface Specifications.”

Other Functions

Storing/Recalling Measured Data

Up to 2000 data sets can be stored. Each data set contains the measured value obtained from each measurement.

A data set is stored or recalled at every trigger occurrence.

Initializing settings

The settings can be reset to factory default values or initial values.

Measurement Mode/SETUP mode

The instrument has two modes, measurement and SETUP modes. You can switch between the modes as necessary.

Measurement mode: This mode measures and displays the resistance. Only the R/% key, SETUP/MEAS key (SHIFT+R/% key), and STORE DATA key (SHIFT+0 key) are enabled. Since all other keys are locked, an erroneous operation resulting from pressing the wrong keys can be avoided.

However, the TRIG key is enabled when the trigger mode is set to [MANUAL] and the RECALL DATA key is enabled when recalling data.

SETUP mode: This mode is used to change the instrument's settings. No measurements can be made in this mode.

Limit Mode (Deviation/Absolute)

You can select whether to use a deviation (%) or an absolute value (R) to specify the limit value (LO, HI) that is used when determining the result with the comparator function.

The comparator determines the result using deviation (%) if you set the limit mode to deviation. The measured value can then be displayed using % or Ω .

The comparator determines the result using absolute value (R) if you set the limit mode to absolute mode (R). The measured value is displayed using Ω . In this mode, the comparator function works only for the 1 Ω range.

1.3 Digital Numbers and Characters and A List of Menus

Digital Numbers and Characters

Because the instrument's display is a seven-segment LED, the following special characters are used to represent the alphanumeric characters. Some characters are not used by the instrument.

0 → 0	A → <i>A</i>	K → <i>k</i>	U → <i>u</i>	^ (power) → <i>^</i>
1 → <i>1</i>	B → <i>b</i>	L → <i>l</i>	V → <i>v</i>	
2 → <i>2</i>	C → <i>C</i> Lower case c → <i>c</i>	M → <i>m</i>	W → <i>w</i>	
3 → <i>3</i>	D → <i>d</i>	N → <i>n</i>	X → <i>x</i>	
4 → <i>4</i>	E → <i>E</i>	O → <i>o</i>	Y → <i>y</i>	
5 → <i>5</i>	F → <i>F</i>	P → <i>p</i>	Z → <i>z</i>	
6 → <i>6</i>	G → <i>G</i>	Q → <i>q</i>	+ → <i>+</i>	
7 → <i>7</i>	H → <i>H</i> Lower case h → <i>h</i>	R → <i>r</i>	- → <i>-</i>	
8 → <i>8</i>	I → <i>i</i>	S → <i>s</i>	x → <i>x</i>	
9 → <i>9</i>	J → <i>j</i>	T → <i>t</i>	+□ → <i>+□</i>	

A List of Menus

In this section, a list of menus for the SETUP mode is given for each operation key. For information regarding the EXIT and <, > keys, see section 2.2, "Keys and Error Displays."

Top menu of the SETUP mode

The first menu displayed in the main display in the SETUP mode is called the top menu. The display returns to this menu when you confirm a setting or when you exit from a menu. The top menu varies depending on the limit mode setting as follows:

When the limit mode is set to % (PCnt) : *PCnt*
 When the limit mode is set to R (OHm) : *OHm*

Limit mode setting menu (page 4-1)

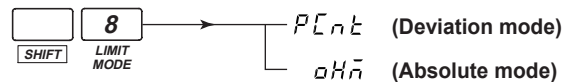

Reference setting menu (page 4-2)

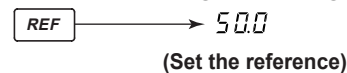

Contact check setting menu (page 4-7)

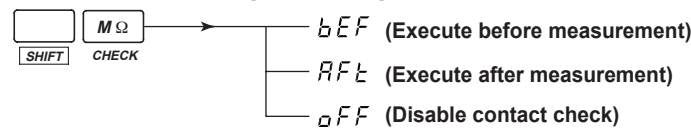

Measurement time selection menu (page 4-8)

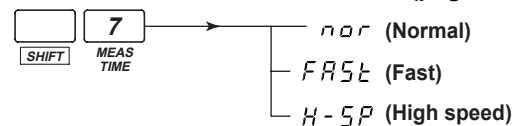

Trigger mode setting menu (page 4-9)

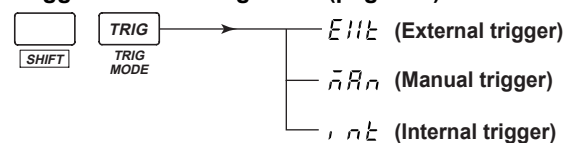

Measured data store menu (page 6-1)

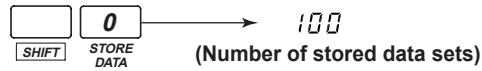

Measured data recall menu (page 6-1)

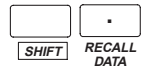

Communication interface setting menu (page 8-7 and 9-6)

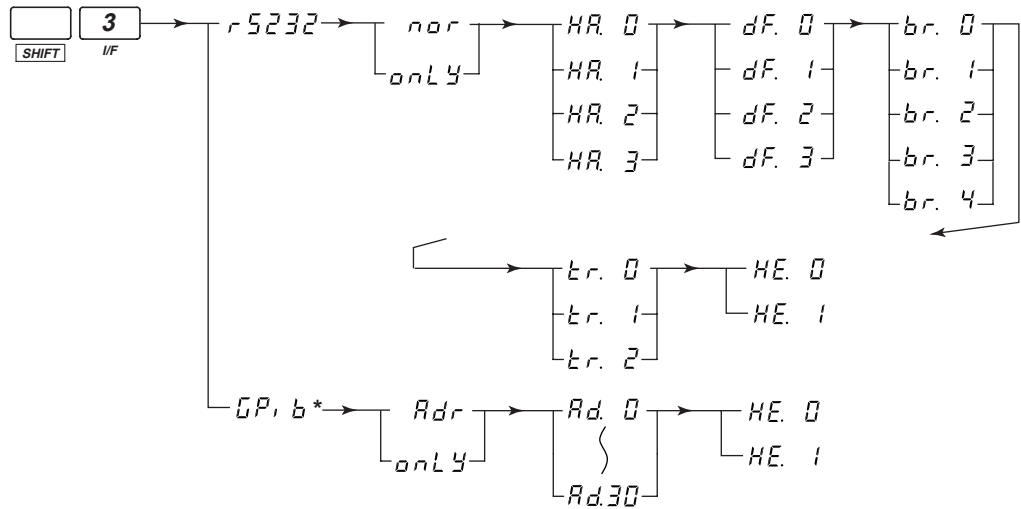

* Displayed only on instruments that have the optional GP-IB interface.

1.3 Digital Numbers and Characters and A List of Menus

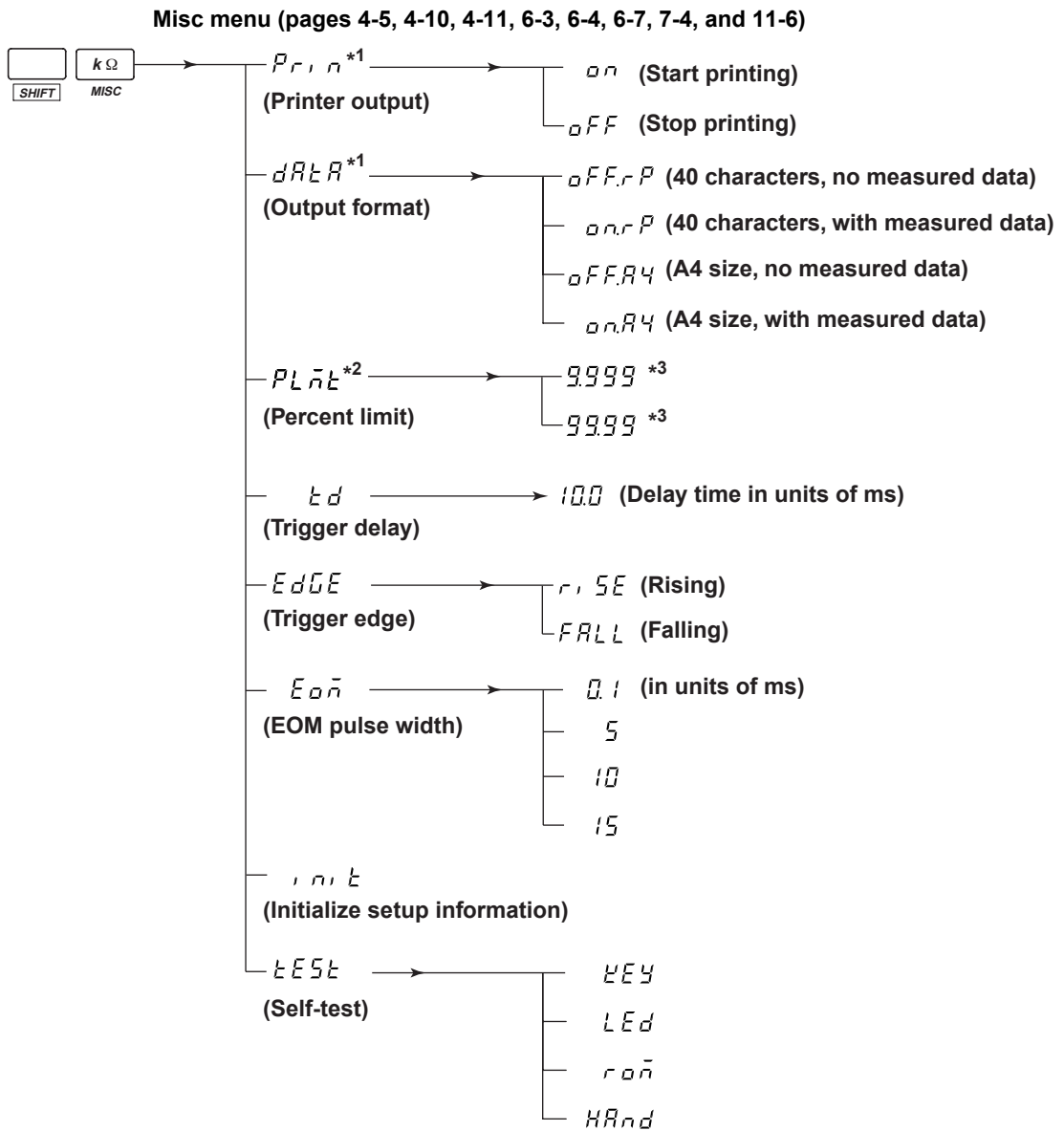

*1 Displayed on instruments that have the optional Centronics interface.

*2 Not displayed when the limit mode is set to absolute mode (R).

*3 For the 755611. "9.99" or "99.9" is displayed on the 755601.

1.4 A List of Initial Values

Parameter	Factory Default	Initial Settings	Resume Function*
Display	Deviation	Deviation	Yes
Deviation reference (REF)	100 k Ω	100 k Ω	Yes
Measurement time	NORMAL	NORMAL	Yes
Trigger mode	EXTERNAL	EXTERNAL	Yes
Trigger delay	0 ms	0 ms	Yes
Contact check function	ON	ON	Yes
Contact check timing	Before	Before	Yes
Contact check level	30 Ω	30 Ω	Yes
HI limit	0%	0%	Yes
LO limit	0%	0%	Yes
Measured data store	OFF	OFF	No
Number of stored data	100	100	Yes
Contents of the stored data	Cleared	Cleared	No
Measured data recall	OFF	OFF	No
SETUP/MEAS	SETUP	SETUP	Yes
Limit mode	PCNT	PCNT	Yes
Percent limit	9.99	9.99	Yes
EOM width	10 ms	10 ms	Yes
Communication interface	Serial (RS232)	Previous condition	Yes
Serial (RS232)			
Mode	Normal	Previous condition	Yes
Handshaking	0	Previous condition	Yes
Data format	0	Previous condition	Yes
Baud rate	3	Previous condition	Yes
Terminator	0	Previous condition	Yes
Header	0	Previous condition	Yes
GP-IB			
Mode	Addressable	Previous condition	Yes
Address	1	Previous condition	Yes
Header	0	Previous condition	Yes
Printer (option)	OFF	OFF	No
Print out of measured data	OFF.rP	OFF.rP	Yes

Yes: enabled, No: disabled

* Resume function: A function in which the setup information is stored when the power is turned OFF and recalled when it is turned ON again.

2.1 Names of Parts

Front Panel

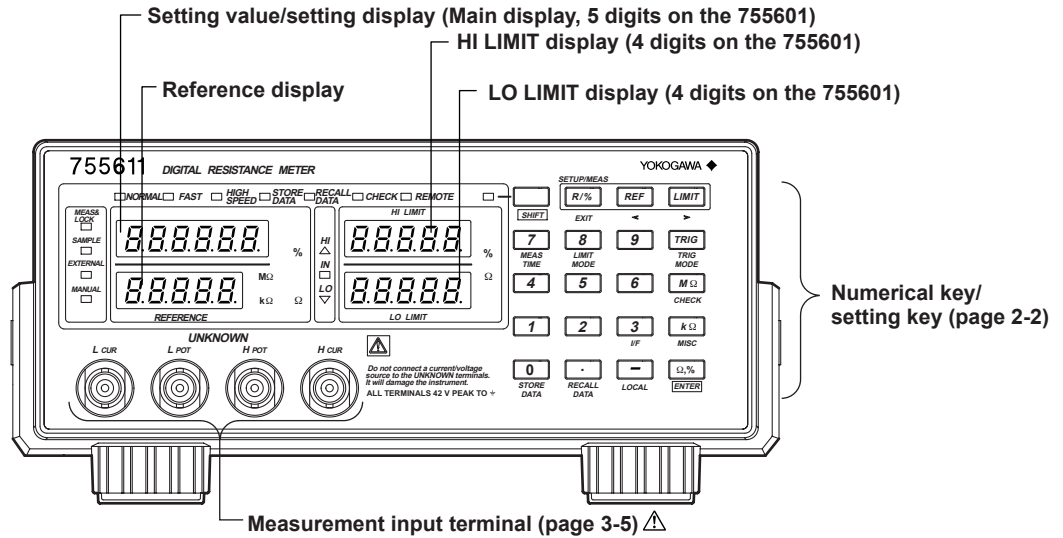

755601 Display Screen

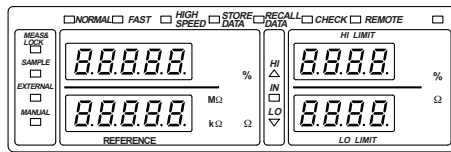

Rear Panel (for both 755601, 755611)

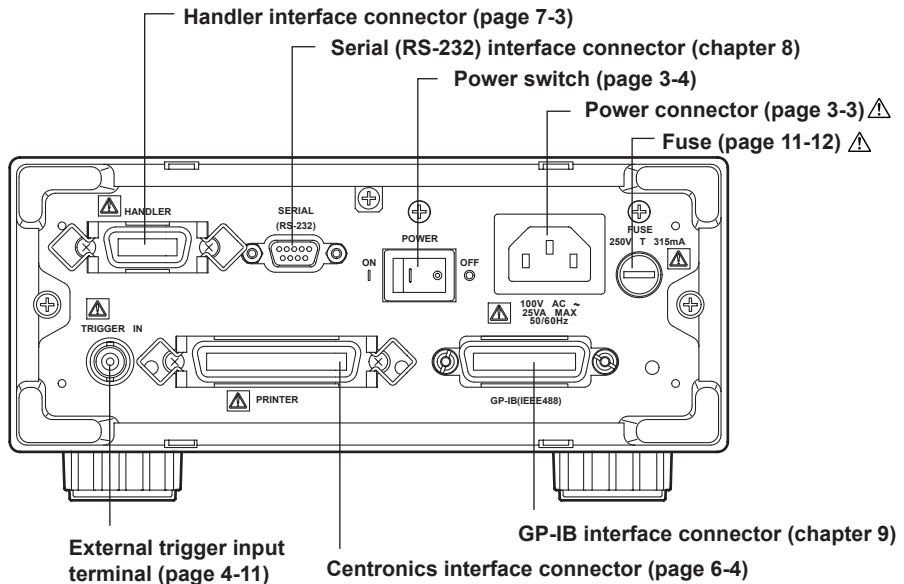

2.2 Keys and Error Displays

Display

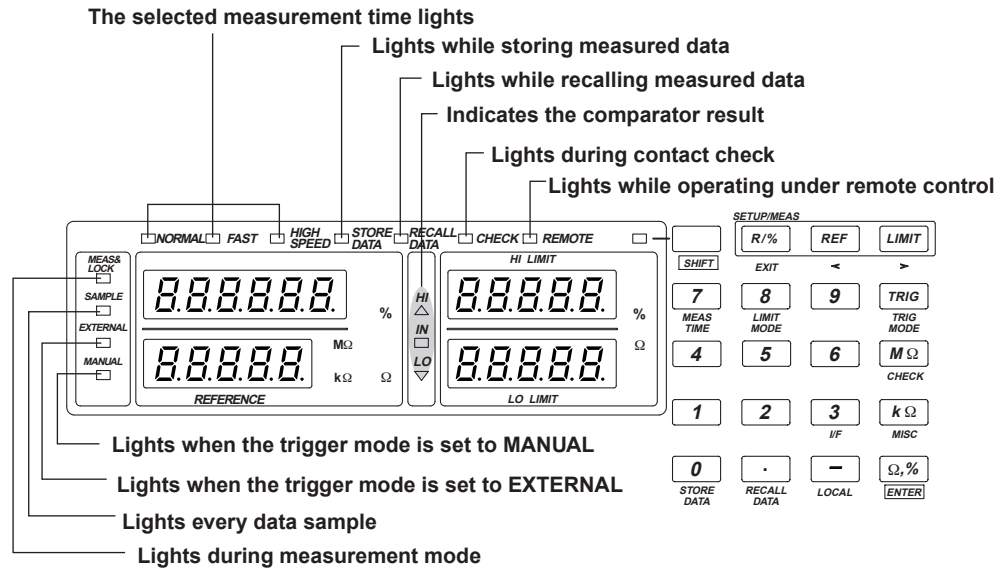

Switching between measurement mode and SETUP mode

SETUP/MEAS (SHIFT+R/%) key

This key is used to switch between measurement mode and SETUP mode. The instrument is in the measurement mode when the "MEAS & LOCK" indicator is lit.

Keys used during the measurement mode

R/% key

This key is used to switch the unit between absolute (R) and deviation (%) in which the measured value is displayed. When the limit mode is set to absolute (R), pressing this key will have no effect.

Keys used during the SETUP mode

SHIFT key

Pressing this key once causes the keys to enter the shifted condition. Pressing it again clears the shifted condition. During the shifted condition, the functions indicated in purple characters are effective. The shifted condition is indicated by a lit indicator to the left of the SHIFT key.

EXIT(R/%) key

Used to cancel the setting operation. Pressing this key cancels the specified settings and causes the instrument to return to the top menu of the SETUP mode.

REF key

When the limit mode is set to deviation (%), this key is used to set the range (reference).

LIMIT key

Used to set the upper and lower limits.

<(REF) key

- When entering numbers (using the numerical keys), this key operates as a backspace key.
- This key is also used when selecting a parameter in the SETUP menu.

>(LIMIT) key

- When entering numbers, this key operates as a clear key.
- It is also used when selecting a parameter in the SETUP menu.

Numerical keys

- Used when entering numerical values. These keys are valid only when entering numbers.
- The $M\Omega$, $k\Omega$, Ω , and % keys are used to set a unit on the numerical value.

TRIG key

When the trigger mode is set to manual trigger, pressing this key activates a trigger.

MEAS TIME(SHIFT+7) key

Used to select the measurement time.

LIMIT MODE(SHIFT+8) key

Used to select the limit mode between deviation (%) and absolute (R).

CHECK(SHIFT+MW) key

Used to set the contact check function.

I/F(SHIFT+3) key

Used to set the serial (RS-232) interface or the optional GP-IB interface.

MISC(SHIFT+kW) key

Used to set the trigger delay and other parameters.

STORE DATA(SHIFT+0) key

Used when storing the measured data.

RECALL DATA(SHIFT+.) key

Used when recalling the measured data.

LOCAL key

Clears the remote mode.

ENTER(Ω ,%) key

Used to confirm a specified value or parameter.

Error Display

Overrange display

When the measured value exceeds the display range or the maximum display value for the corresponding measurement range, an overrange results. The display shows the following when the measured value is over the range.

"- O.L -"

Display when an abnormality is detected in the test current

The display when an abnormality is detected in the test current shows the following:

"- [F] -"

Contact check error display

When using the contact check function to make measurements, the display shows the following when a contact check error occurs.

"- n.C -"

Other error displays

When an error that is described in section 11.2 "Messages and Corrective Actions" occurs, the corresponding error code is displayed as follows:

"E.888" or "E- 102"

Bar Display

When the mode is switched from the SETUP mode to the measurement mode, the display shows the following until the first measured value is displayed.

"- - - - -"

3.1 Precautions on the Use of the instrument

Safety Precautions

If you are using this instrument for the first time, make sure to thoroughly read the “Safety Precautions” given on page iii.

- Do not remove the cover from the instrument. Some sections inside the instrument have high voltages that are extremely dangerous. For internal inspection or adjustment, contact your nearest YOKOGAWA dealer as listed on the back cover of this manual.
- Never continue to use the instrument if there are any symptoms of trouble such as strange smells or smoke coming from the instrument. In such cases, immediately turn OFF the power and unplug the power cord. Then, contact your nearest YOKOGAWA dealer as listed on the back cover of this manual.
- Nothing should be placed on top of the power cord. The power cord should also be kept away from any heat sources. When unplugging the power cord from the outlet, never pull the cord itself. Always hold the plug and pull it. If the power cord is damaged, contact your dealer for replacement. Refer to page ii for the part number when placing an order.

General Handling Precautions

- Never place any objects containing water on top of the instrument. This may cause problems.
- Do not apply shock to the input section. Applying shock to the input terminal or the probe can cause electrical noise to enter the instrument.
- When the instrument is not being used for an extended period of time, unplug the power cord from the outlet.
- When moving the instrument, first, turn OFF the devices under measurement and remove all measurement wires and communication cables. Then, turn OFF the instrument and remove the power cord from the outlet. To carry the instrument, use the handle (see figure below) or carry it using both hands.

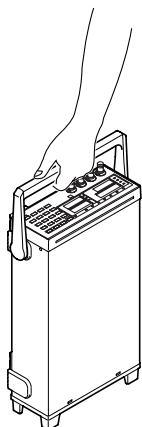

- Keep electrically charged objects away from the input terminals. They may damage the internal circuitry.
- Do not pour volatile agents on the case nor leave the case in contact with rubber or PVC products for long periods of time. The case is made of a thermoplastic resin, so take care not to let anything hot such as a soldering iron touch the case.
- When cleaning the case or the operation panel, remove the instrument's power cord from the outlet. Then, wipe with a dry, soft cloth. Do not use volatile chemicals since this might cause discoloring and deformation.

3.2 Installing the Instrument

Installation condition

Install the instrument in a place that meets the following conditions.

Flat, even surface

Install the instrument on a stable horizontal surface. Otherwise, precise measurements may be impeded.

Ambient temperature and humidity

Ambient temperature: 5 to 40°C

Ambient humidity: 20 to 80%RH (no condensation)

Do not install the instrument in the following places:

- Outdoor.
- In direct sunlight or near heat sources.
- Where an excessive amount of soot, steam, dust, or corrosive gases are present.
- Where the instrument is exposed to water or other liquids.
- Near strong magnetic field sources.
- Near high voltage equipment or power lines.
- Where the level of mechanical vibration is high.
- In an unstable place.
- In a place where the power switch cannot be accessed easily.

Note

- For the most accurate measurements, use the instrument in the following environment.
Ambient temperature: $23 \pm 3^\circ\text{C}$, ambient humidity: 30 to 75%RH (no condensation)
When using the instrument in a place where the ambient temperature is 5 to 18°C or 28 to 40°C, add the temperature coefficient to the accuracy of the module as specified in chapter 12, "Specifications."
- When installing the instrument in a place where the ambient humidity is 30% or below, take measures to prevent static electricity such as using an anti-static mat.
- Internal condensation may occur if the instrument is moved to another place where both the ambient temperature and humidity are higher, or if the temperature changes rapidly. In this case, let the instrument adjust to the new environment for at least one hour before using the instrument. Check to see that there is no condensation.

Installation position

Place the instrument on a flat, even surface as shown in the figure below. To adjust the handle position, pull the handle outward on each side along the axis of rotation by 2 to 3 mm, then slowly rotate the handle to another locked position.

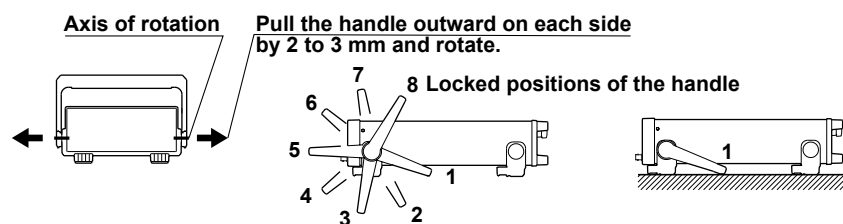

Storage Location

Do not store the instrument in the following kinds of places:

- Where the relative humidity is 80% or higher or where the temperature is 60°C or higher
- In direct sunlight or near heat sources
- Where an excessive amount of dust, salt, or iron is present
- Where there are corrosive or explosive gases
- Where water, oil, or chemicals may splash
- Where the level of mechanical vibration is high

We recommend that the instrument be stored in an environment where the temperature is between 5 and 40°C and the relative humidity is between 20 and 80% RH.

3.3 Connecting the Power Cord

Before connecting the power

Follow the warnings below to avoid electric shock and damage to the instrument.



WARNING

- Connect the power cord only after confirming that the voltage of the power supply matches the rated electric power voltage for the instrument.
- Connect the power cord after checking that the power switch of the instrument is turned OFF.
- To prevent electric shock or fire, always use the power cord supplied by YOKOGAWA.
- Always use protective grounding to prevent electric shock. Connect the power cord of the instrument to a three-pole power outlet that has a protective grounding terminal.
- Never use an extension cord that does not have protective grounding, otherwise the protection function will be compromised.

Connecting Procedure

1. Check that the power switch on the rear panel is OFF.
2. Connect the plug of the power cord that is included in the package to the power connector on the rear panel of the instrument.
3. Plug the other end of the power cord into a power outlet that satisfies the conditions below. The AC outlet must be a three-pole type that has a protective grounding terminal.

Item	Suffix Code -1	Suffix Code -4	Suffix Code -6	Suffix Code -8
Rated supply voltage	100 VAC	120 VAC	220 VAC	240 VAC
Permitted supply voltage range	90 to 110 VAC	108 to 132 VAC	198 to 242 VAC	216 to 264 VAC
Rated supply voltage frequency	50/60 Hz	50/60 Hz	50/60 Hz	50/60 Hz
Permitted supply voltage frequency range	47 to 66 Hz	47 to 66 Hz	47 to 66 Hz	47 to 66 Hz
Maximum power consumption	25 VA	25 VA	25 VA	25 VA

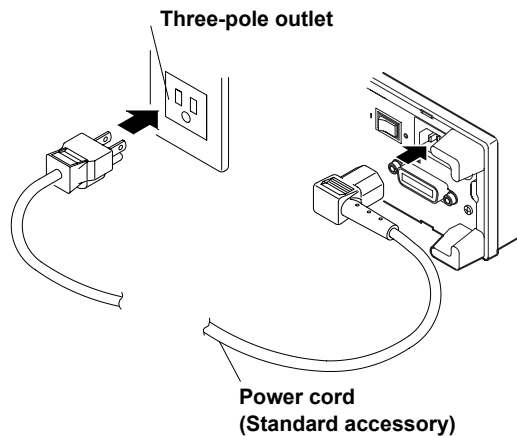

Turning the Power Switch ON/OFF

Points to Check before Turning ON the Power

- Is the instrument properly installed? See section 3.2, "Installing the Instrument." (page 3-2)
- Is the power cord properly connected? See section 3.3, "Connecting the Power Cord." (page 3-3)

Turning ON/OFF the Power Switch

Turn ON the power by depressing the power switch on the rear panel to the "ON (I)" side and OFF by depressing it to the "OFF (O) side."

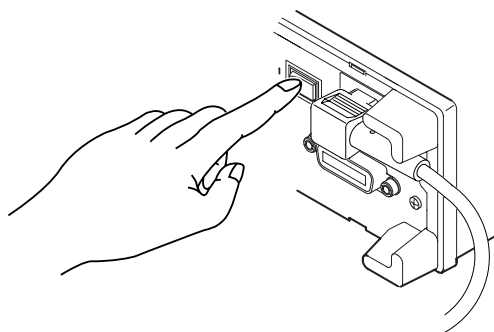

Power Up Operation

When the power switch is turned ON, the instrument automatically starts a self-test. The self-test takes approximately 30 seconds. Upon successful completion, the top menu of the SETUP mode ($P.L.n.t$ or $.o.H.n$) appears or the instrument enters the measurement mode (the instrument recalls the condition that existed when the power was turned OFF).

To make a measurement, press the SETUP/MEAS key (SHIFT+R/% key) to switch to the measurement mode.

If the Instrument Does Not Start Normary When the Power Is Turned On

If the instrument fails to power up as described or the top menu does not appear, turn OFF the power switch and check the following points.

- Is the power cord securely connected?
- Is the correct voltage coming to the power outlet? See page 3-3.
- If the power switch is turned ON while pressing the SHIFT key, the setup parameters are initialized to their factory default values. For details regarding initialization, see section 6.3, "Initializing Setup Parameters" on page 6-7.

If the instrument still fails to power up after checking these points, contact your nearest YOKOGAWA dealer for repairs.

For Making Accurate Measurements

Allow the instrument to warm up for at least 30 minutes after turning ON the power switch.

Shut Down Operation

The setup parameters that exist immediately before the power switch is turned OFF are stored in memory. The same is true when the power cord gets disconnected from the outlet. The next time the power switch is turned ON, the instrument powers up using the previous settings that existed immediately before the power was turned OFF.

Note

A lithium battery is used to retain the setup parameters. The battery has a limited lifetime. When the lithium battery voltage falls below a certain level, a "901" error code is displayed on the screen when the power switch is turned ON. When this error code appears, the battery must be replaced quickly. The user cannot replace the battery. For battery replacement, contact your nearest YOKOGAWA dealer.

3.4 Wiring



CAUTION

Do not apply any voltage or current across the measurement input terminals and across the measurement input terminal and the guard (the outside of the BNC connector). The maximum common-mode voltage across the case and input terminals is ± 42 Vpeak. Not meeting these conditions can damage the instrument.

Wiring Method

Connect BNC cables to each terminal as shown in the figure below.

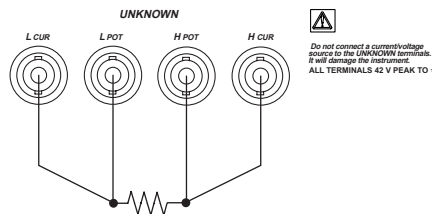

Resistor under measurement

Wiring Precautions

The accuracy specifications can only be met if the following conditions, given in the wiring example below, are provided.

Wiring Example

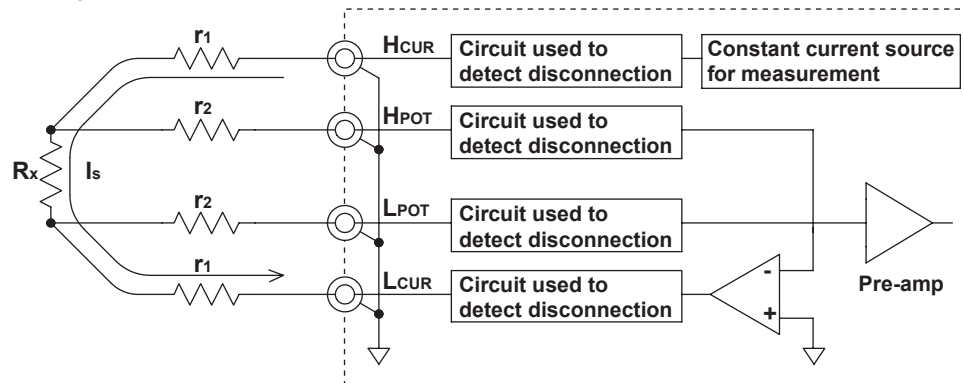

Is: Test current

Rx: Resistor under measurement

r1, r2: Resistance of the lead wires (includes contact resistance)

$Is \times r1 \leq 1.5$ V:

For checking the normal operation of the constant current source

$r2 \leq 15 \Omega$ (for 1 Ω range):

Because the circuit used to detect disconnection feeds a

$r2 \leq 30 \Omega$ (for other ranges)

minimal amount of current so that it can detect disconnection during measurement.

3.3 Connecting the Power Cord

Note

- When measuring a resistor that contains capacitive components in parallel, the response becomes slow and correct measurements may not be obtained. In this case, turn OFF the contact check function, and perform the measurement after the response is adequately stable.
 - Since this instrument applies a pulse current to make measurements, when measuring a resistor that has inductive components in series (wire wound resistor, for example), the response becomes slow and correct measurements may not be obtained. In addition, if the inductance exceeds 10 μH , it can cause resonance.
 - To minimize the influence from noise, make the lead wires as short as possible, and use shielded cables. In addition, placing the resistor under measurement inside a shielded case and connecting the guard (outside of the BNC connector) and the shielded case with shielded cables are effective means of preventing noise.
 - Keep the capacitance of the shielded cable between the measurement input terminal and guard (outside of the BNC connector) under 300 pF. Resonance can result if this value is exceeded.
 - Do not connect the input terminals and the guard. Measurements cannot be made, under this condition.
 - For absolute value display (R), drifting occurs near the zero point when the input is shorted, possibly resulting in the display of a negative value.
For deviation display (%), the display corresponding to -100% (when the input is shorted, for example) is represented by -99.9%, -99.99%, or -99.999%.
-

4.1 Switching the Limit Mode

Keys

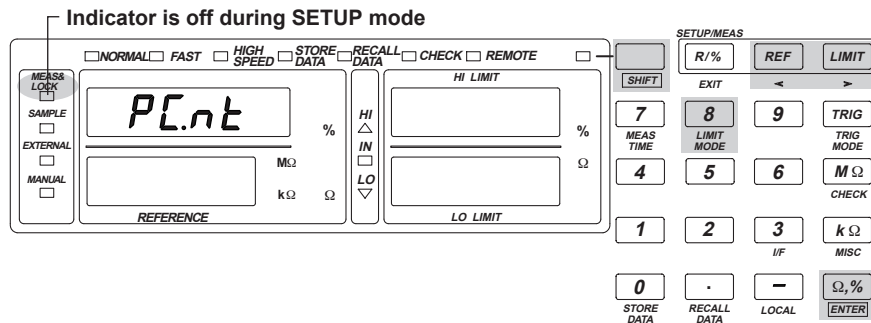

Procedure

The items that are specified or selected are confirmed when the ENTER ($\Omega, \%$) key is pressed. To exit from a menu in the middle of the operation, press the EXIT (R/%) key.

Switching to the SETUP mode

1. Press the SHIFT $\text{R}/\%$ key to switch to the SETUP mode. If the "MEAS & LOCK" indicator is off, this operation is not necessary.

Switching the limit mode

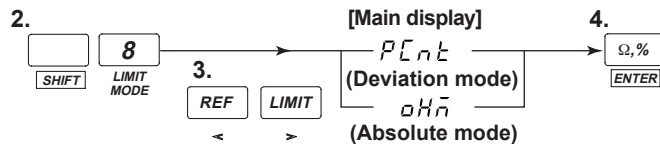

Explanation

There are two limit modes.

You can select whether to use a deviation (%) or an absolute value (R) for the comparator function.

- Deviation (%) mode: The measured value is handled as a deviation from the specified reference value. The comparator function is also carried out in terms of the deviation.
- Absolute (R) mode: The measured value is handled as an absolute value. The comparator function is also carried out in terms of the absolute value.

Precautions to be taken when switching the limit mode

The following parameters are initialized when the limit mode is switched.

HI level, LO level, and REF (reference, when the limit mode is set to %)

4.2 Changing the Range (Reference)

When the limit mode is set to deviation (%)

Keys

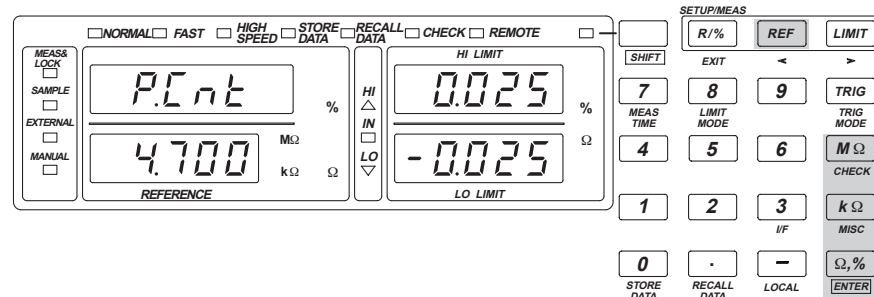

Procedure

The items that are specified or selected are confirmed when the $M\Omega$, $k\Omega$, or ENTER ($\Omega, \%$) key is pressed. When confirmed, the new reference is displayed.

To exit from a menu in the middle of the operation, press the EXIT (R/%) key. The display returns to the top menu of the SETUP mode.

Switching to the SETUP mode

1. Press the SHIFT $\text{R}/\%$ key to switch to the SETUP mode. If the "MEAS & LOCK" indicator is off (if PCnt or oHm is displayed on the main display), this operation is not necessary.

Changing the reference value

2. REF → [REFERENCE display]
3. Numerical keys → 10.000
4. $M\Omega$ (Press when the unit is $M\Omega$.)
 $k\Omega$ (Press when the unit is $k\Omega$.)
 $\Omega, \%$ (Press when the unit is Ω .)

If the value entered using the numerical keys is not correct, an error (810) is displayed for approximately one second, and the display returns to step 3.

Explanation

When the reference value is entered, the range is automatically determined. The range and the display range are set according to the specified reference as follows. For the procedure to set the percent limit, see section 4.3, "Using the Comparator Function."

When the percent limit is set to 9.99%

Reference	Range	Display Range
0.0001 to 1.0009 Ω	1 Ω	"-99.999%
1.001 to 10.009 Ω	10 Ω	to
10.01 to 100.009 Ω	100 Ω	19.999%"
0.1001 k to 1.0009 k Ω	1 k Ω	(for 755611)*1
1.001 k to 10.009 k Ω	10 k Ω	
10.01 k to 100.09 k Ω	100 k Ω	
0.1001 M to 1.0009 M Ω	1 M Ω	
1.001 M to 10.009 M Ω	10 M Ω	
10.01 M to 120.00 M Ω	100 M Ω	

*1 "-99.99% to 19.99%" for 755601

When the percent limit is set to 99.9%

Reference	Range	Display Range
0.001 to 1.009 Ω	10 Ω	"-99.99%
1.01 to 10.09 Ω	100 Ω	to
10.1 to 100.09 Ω	1 k Ω	199.99%"
0.101 k to 1.009 k Ω	10 k Ω	(for 755611) ^{*2}
1.01 k to 10.09 k Ω	100 k Ω	
10.1 k to 100.9 k Ω	1 M Ω	
0.101 M to 1.009 M Ω	10 M Ω	
1.01 M to 10.09 M Ω	100 M Ω	
10.1 M to 120.0 M Ω	100 M Ω	

*2 "-99.9% to 199.9%" for 755601

When the limit mode is set to absolute (R)

When the limit mode is set to absolute (R), the range is fixed to 1 Ω . You cannot change this value.

Maximum displayed value: 1.20000 (755611)
 1.2000 (755601)

Measurement resolution: 10 $\mu\Omega$ (755611)
 100 $\mu\Omega$ (755601)

4.3 Using the Comparator Function

When the limit mode is set to deviation (%)

Keys

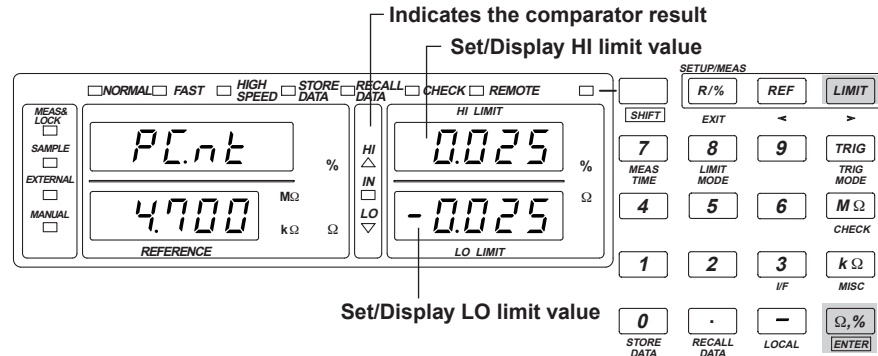

Procedure

The items that are specified or selected are confirmed when the ENTER ($\Omega, \%$) key is pressed. When confirmed, the new limit is displayed.

To exit from a menu in the middle of the operation, press the EXIT (R/%) key. The display returns to the top menu of the SETUP mode.

Switching to the SETUP mode

1. Press the $\frac{\text{SETUP/MEAS}}{\text{SHIFT}} \text{ R/\%}$ key to switch to the SETUP mode. If the "MEAS & LOCK" indicator is off, this operation is not necessary.

Changing the limit value (HI and LO values)

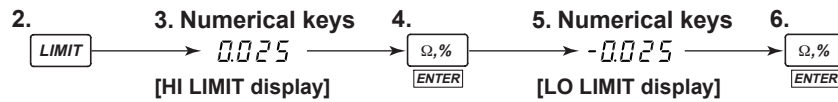

If the value entered using the numerical keys is not correct, an error (810) is displayed for approximately one second, and the display returns to step 3.

Selecting the percent limit

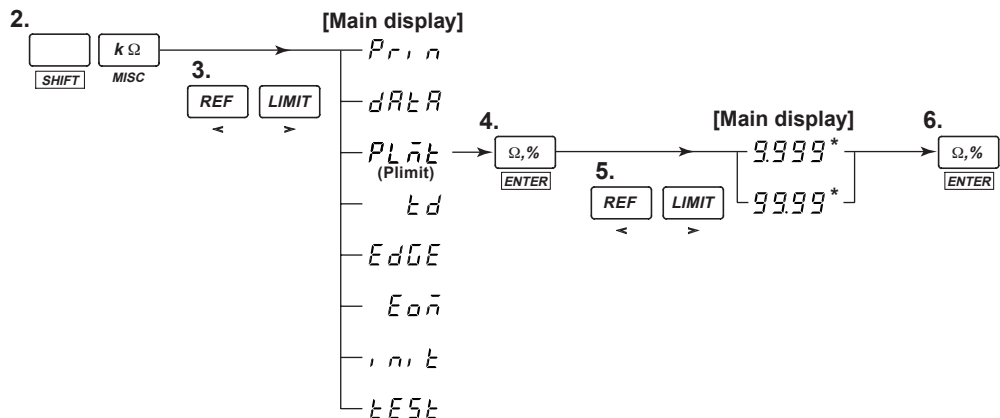

* For 755611. For 755601, select either "9.99" or "99.9."

Explanation**Setting range of limit values (HI and LO values)**

The limit value is set in terms of the deviation (%) from the reference value that was set in section 4.3, "Changing the Range (Reference)."

Limit Value	Setting Range	
	When the percent limit is 9.99%	When the percent limit is 99.9%
Applies to both LO, HI	-9.999% to 9.999% (755611) -9.99% to 9.99% (755601)	-99.99% to 99.99% (755611) -99.9% to 99.9% (755601)

However, $LO \leq HI$

Note

If the values are set so that HI is less than LI, an error (815) occurs.

Selecting the percent limit

Percent limit refers to the display resolution when the measured values are handled in terms of deviation (%).

Select the percent limit from the following two choices.

9.99%

99.9%

Note that depending on the selected percent limit, the range of limit values (LO and HI values) varies as indicated in the above section "Setting range of limit values (HI and LO values)."

Note

- Changing the percent limit initializes the limit values (HI and LO) to 0%.
- If the percent limit is changed from 9.99% to 99.9%, the reference value is rounded to the least significant digit. However, if the limit mode is 9.99% and the reference value is between 0.0001 Ω to 0.0004 Ω , changing the limit mode to 99.9% changes the reference value to 0.001 Ω .

Comparator function

The measured value is compared to the specified limit values (HI and LO) and the result is indicated by turning ON the appropriate indicator.

The comparator result is also output from the handler interface.

The following comparison is made.

When the measured value > HI : "HI" (▲ indicator) turns ON (red)

When the measured value < LO : "LO" (▼ indicator) turns ON (red)

When the measured value is between LO and HI : "IN" (■ indicator) turns ON (green)

"-OL-" (overrange), : "HI" (▲ indicator) turns ON (red)

"-nC-" (contact check error),

"-CF-" (Abnormality detected in the test current)

Note

The comparator function is carried out using fractions with greater accuracy than those displayed.

4.3 Using the Comparator Function

When the limit mode is set to absolute (R) Keys

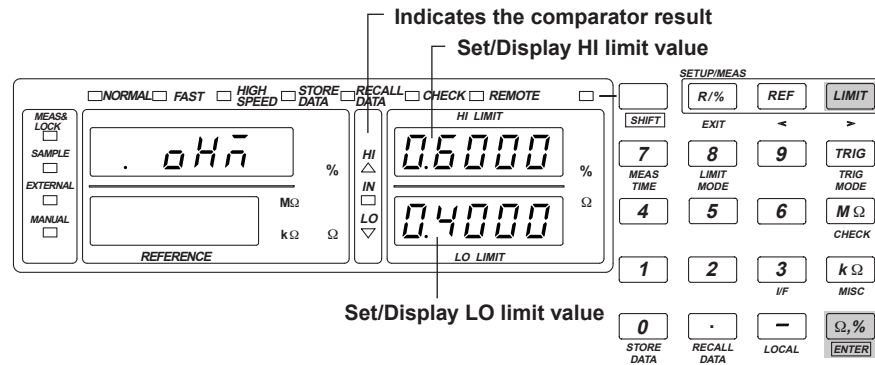

Procedure

The items that are specified or selected are confirmed when the ENTER (Ω, %) key is pressed. When confirmed, the new reference is displayed.

To exit from a menu in the middle of the operation, press the EXIT (R/%) key. The display returns to the top menu of the SETUP mode.

Switching to the SETUP mode

1. Press the key to switch to the SETUP mode. If the “MEAS & LOCK” indicator is off, this operation is not necessary.

Changing the limit values

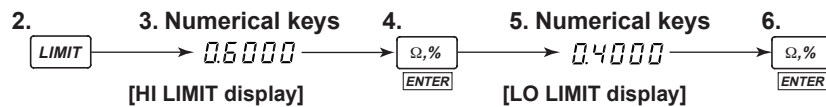

If the value entered using the numerical keys is not correct, an error (810) is displayed for approximately one second, and the display returns to step 3.

Explanation

Setting range of limit values

The setting range applies to both HI and LO.

Model	Setting Range	Resolution
755601	0.000 Ω to 1.200 Ω	1 mΩ
755611	0.0000 Ω to 1.2000 Ω	100 μ Ω

However, LO ≤ HI

Note

If the values are set so that HI becomes less than LI, an error (815) occurs.

Comparator function

Same as the description given in “When the limit mode is set to deviation (%).” See page 4-5.

4.4 Using the Contact Check Function

Keys

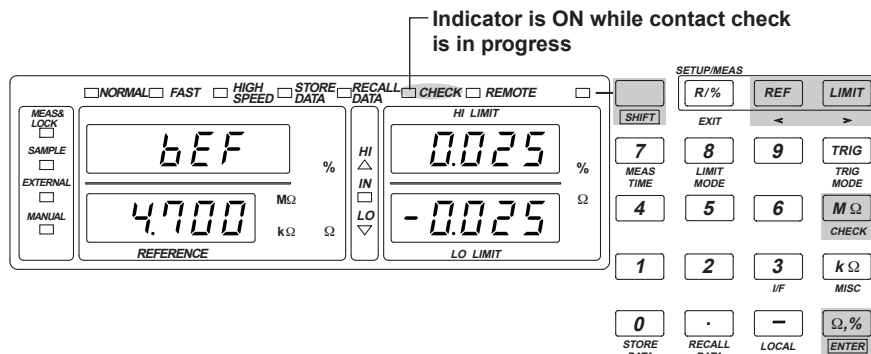

Procedure

The items that are specified or selected are confirmed when the ENTER ($\Omega, \%$) key is pressed. When confirmed, the display returns to the top menu of the SETUP mode. To exit from a menu in the middle of the operation, press the EXIT (R/%) key. The display returns to the top menu of the SETUP mode.

Switching to the SETUP mode

1. Press the $\left[\begin{smallmatrix} \text{SHIFT} \\ \text{R/\%} \end{smallmatrix} \right]$ key to switch to the SETUP mode. If the “MEAS & LOCK” indicator is off, this operation is not necessary.

Using the contact check

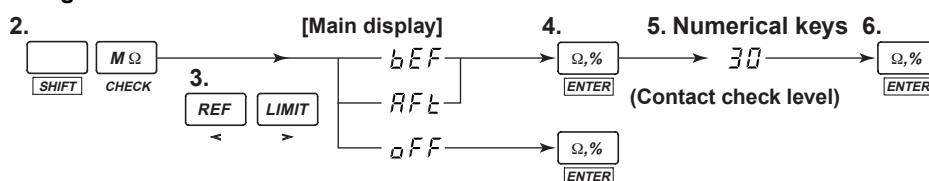

If the value entered using the numerical keys is not correct, an error (810) is displayed for approximately one second, and the display returns to step 5.

Explanation

Contact check function

If the result of the contact check is larger than the specified check level, an error is generated. The time duration of the check is 2 ms, and the check current is 50 mA. The timing to perform the contact check can be selected from the following choices.

- OFF: Contact check is not performed.
- bEF: Contact check is performed before the measurement. If an error is detected, “-nC-” is displayed and the “HI” indicator (\blacktriangle) turns ON. “HI” “NO CONTACT” signal is output from the handler interface.
- AfT: Contact check is performed after the measurement. If an error is detected, “-nC-” is displayed and the “HI” indicator (\blacktriangle) turns ON. “HI” “NO CONTACT” signal is output from the handler interface.

Setting range of the check level

1 to 30 Ω (1 Ω resolution).

4.5 Setting the Measurement Time

Keys

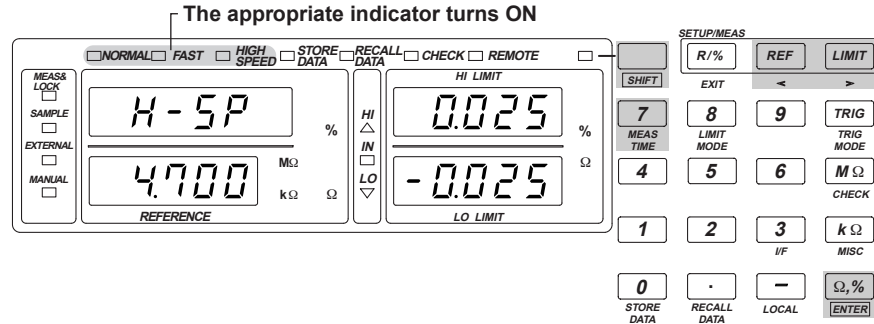

Procedure

The items that are specified or selected are confirmed when the ENTER ($\Omega, \%$) key is pressed. When confirmed, the display returns to the top menu of the SETUP mode. To exit from a menu in the middle of the operation, press the EXIT (R/%) key. The display returns to the top menu of the SETUP mode.

Switching to the SETUP mode

1. Press the SHIFT $\text{R}/\%$ key to switch to the SETUP mode. If the "MEAS & LOCK" indicator is off, this operation is not necessary.

Selecting the measurement time

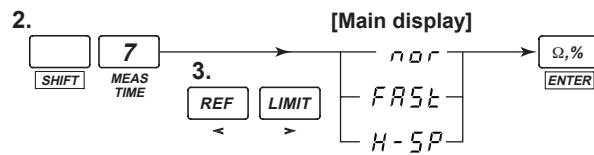

Explanation

Measurement time

Select from the following choices.

Type	Measurement Time* (when the measurement range is 1 Ω to 1 M Ω)
nor (NORMAL)	19.9 ms (for 60 Hz) 23.2 ms (for 50 Hz)
FAST (FAST)	5.7 ms
H-SP (HIGH SPEED)	2.8 ms

* Measurement time: When the trigger mode is set to EXTERNAL, the time from the trigger input to the falling edge of the EOM signal of the handler interface is called the measurement time. When the trigger mode is set to Manual or Internal, the EOM signal is not output. When the contact check function is ON (before the measurement), add 2 ms. When the contact check function is ON (after the measurement), add 1 ms. When a trigger delay is specified, add the delay time. When the measurement range is 10 M Ω , add 4 ms. When the measurement range is 100 M Ω , add 50 ms.

4.6 Using the Trigger Function

Keys

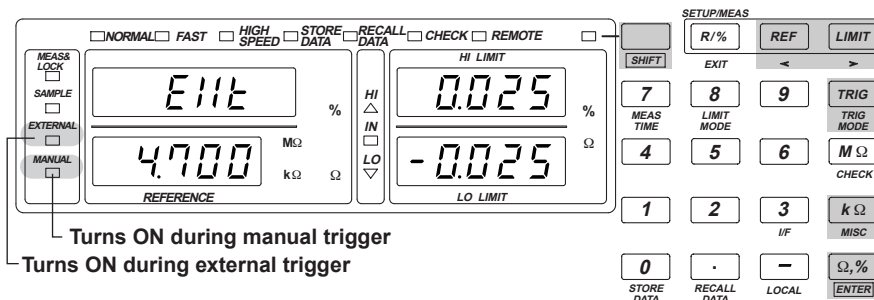

Turns ON during manual trigger
Turns ON during external trigger

Procedure

The items that are specified or selected are confirmed when the ENTER ($\Omega, \%$) key is pressed. When confirmed, the display returns to the top menu of the SETUP mode. To exit from a menu in the middle of the operation, press the EXIT (R/%) key. The display returns to the top menu of the SETUP mode.

Switching to the SETUP mode

1. Press the $\left[\begin{smallmatrix} \text{SHIFT} \\ \text{R/\%} \end{smallmatrix} \right]$ key to switch to the SETUP mode. If the "MEAS & LOCK" indicator is off, this operation is not necessary.

Selecting the trigger mode

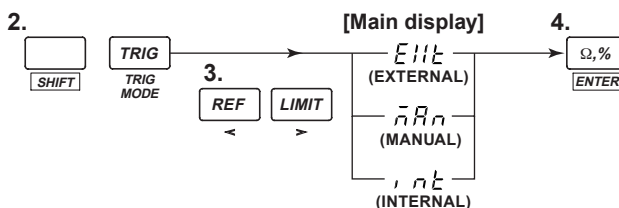

Setting the trigger delay

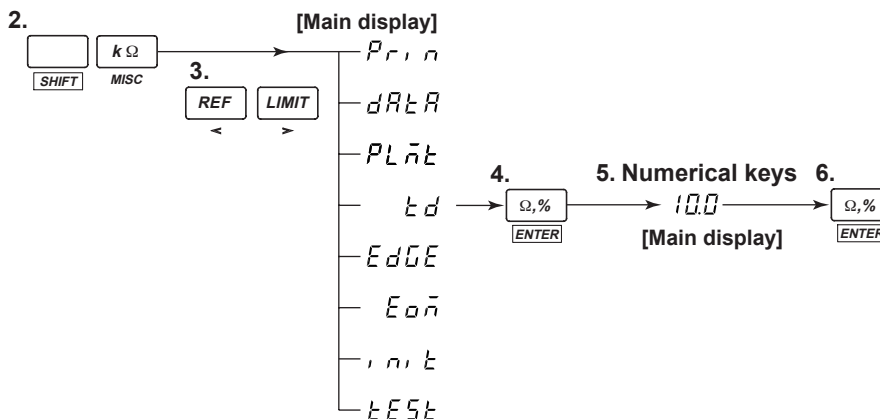

If the value entered using the numerical keys is not correct, an error (810) is displayed for approximately one second, and the display returns to step 5.

4.6 Using the Trigger Function

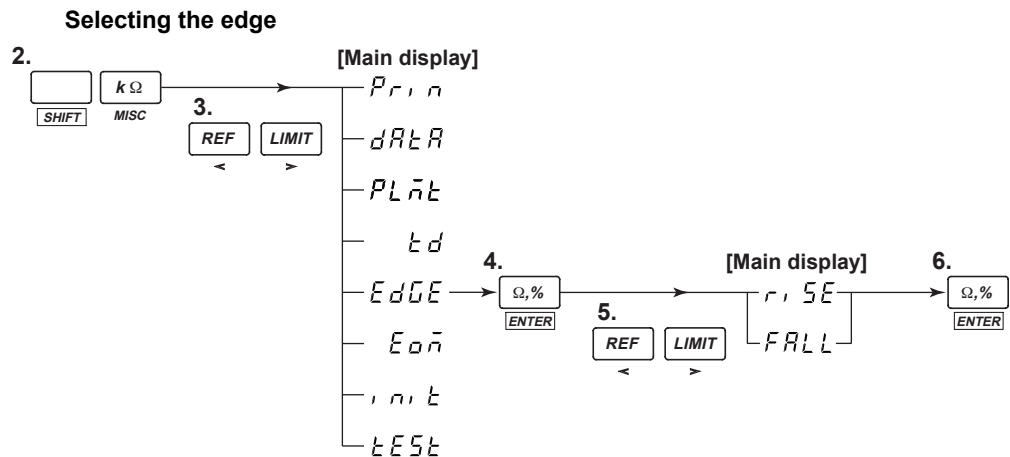

Manual trigger (only when the trigger mode is set to MANUAL)

1. Press the key to switch to the measurement mode.
2. Trigger is activated every time the key is pressed.

Explanation



CAUTION

Applying a voltage outside the 0 to 5 V range to the external trigger input terminal (TRIGGER IN) can damage the instrument.

External trigger input terminal (TRIGGER IN)

Specifications

Connector type : BNC
 Input level : CMOS
 Minimum pulse width : 100 μs

Input circuit (non-isolated)

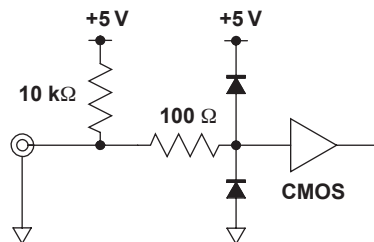

Selecting the trigger mode

Select from the following list of choices.

- EXTERNAL:** Trigger is activated using the input signal at the external trigger input terminal or the number 8 pin of the handler interface, and the measurement is made.
- MANUAL:** Measurement is made when the TRIG key is pressed or when a trigger is activated using a communication command.
- INTERNAL:** Measurement is made at intervals according to the specified measurement time.

Setting the trigger delay

The trigger delay setting takes effect when the trigger mode is set to EXTERNAL or MANUAL.

The range and resolution are as follows:

Range: 0 to 1000 ms

Resolution: 0.1 ms

Selecting the trigger edge

The selected edge takes effect only when the trigger mode is set to EXTERNAL.

Rise (rising edge): Trigger occurs at the rising edge of the signal.

Fall (falling edge): Trigger occurs at the falling edge of the signal.

Measurement interval for INTERNAL (internal trigger)

When the trigger mode is set to INTERNAL, the measurement interval is set to the following values depending on the specified measurement time.

Measurement Time	Measurement Interval
NORMAL	50 ms
FAST	20 ms
HIGH SPEED	10 ms

However, the measurement interval is adjusted by adding the appropriate values for the following cases: 5/10/15 ms when the pulse width of the EOM signal of the handler interface is set to 5/10/15 ms, respectively, 5 ms when the contact check function is ON, 5 ms when the range is 10 M Ω , and 50 ms when the range is 100 M Ω .

5.1 Setting the Measurement Mode

Keys

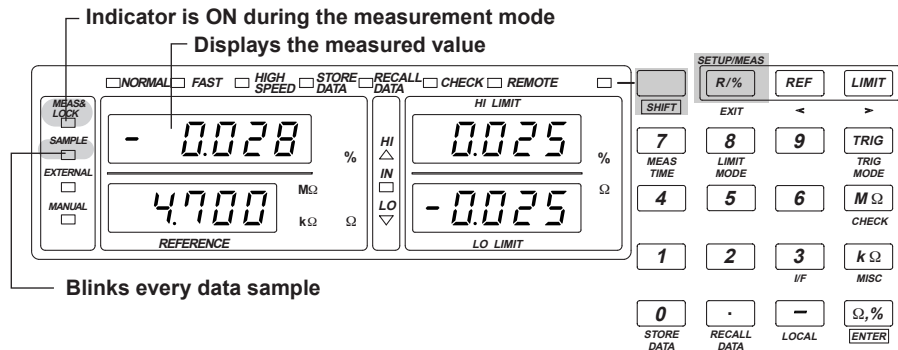

Procedure

Press the key to switch to the measurement mode. If the “MEAS & LOCK” indicator is off, this operation is not necessary.

Explanation

In the measurement mode, measurements are made according to the various specified settings such as the trigger mode, measurement time, and range. The measured value is displayed using seven-segment digital characters.

You can not change the settings in the measurement mode.

The following keys can be used in the measurement mode.

- SETUP/MEAS (SHIFT+R/%) key: Used to switch between the measurement and SETUP modes.
- TRIG key: Pressing this key when the trigger mode is set to MANUAL activates a trigger.
- R/% key: Used to switch the display when the limit mode is set to deviation (%).
- STORE DATA (SHIFT+0) key: Pressing this key while making measurements causes the “STORE DATA” indicator to turn ON and the instrument to enter a state in which data can be stored. Pressing this key while the instrument is storing data terminates the store operation.
- RECALL DATA (SHIFT+.) key: Pressing this key while the instrument is recalling data (“RECALL DATA” indicator is ON) terminates the recall operation.

The error displays for measured values are as follows:

- When the value is over the range:
- When a contact check error occurs:
- When abnormalities are detected in the test current:

For details regarding the error displays, see page 2-4.

5.1 Setting the Measurement Mode

Precautions to be taken during measurement

Precautions on the "HOLD" signal of the handler interface

When the HOLD signal of the handler interface is set to "L," the instrument switches to the measurement mode regardless of the mode it is currently in (the trigger mode is set to EXTERNAL), and makes measurements. Since the SETUP/MEAS key is locked, you will not be able to switch modes using the key. If you wish to do so, first, set the HOLD signal to "H," then change the mode using the key or a communication command. Simply changing the HOLD signal from "L" to "H" does not change the mode. The measurement continues in this case.

Note

Use the SETUP mode to change the reference value and limit values.

Precautions to be taken when using the trigger input signal



When activating the trigger with the input signal applied to the external trigger input terminal on the rear panel or the number 8 pin of the handler interface (EXT TRIG), the unused terminal or pin must be set to open or HI level. Otherwise, the trigger will not function.

5.2 Switching between Deviation (%) and Absolute (R) Displays

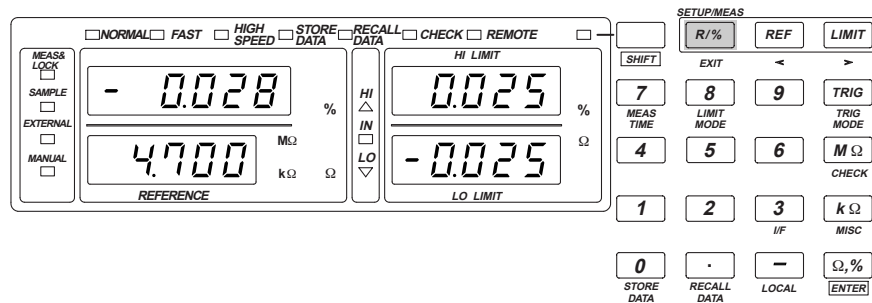
Keys



Procedure

1. Press the   key to switch to the measurement mode. If the “MEAS & LOCK” indicator is off, this operation is not necessary.
2. Press the  key to set the displayed unit of the measured value to % (deviation display) or Ω (absolute display).

Explanation

Switching between the deviation (%) and absolute (R) displays

You can switch the display during measurements (in the measurement mode).

The display unit can be switched only when the limit mode is set to deviation (%).

Note

The measured value displayed in the deviation display may differ from that displayed in the absolute display by one digit due to the different methods used to handle the fractional values.

6.1 Store/Recall Measured Data

Keys

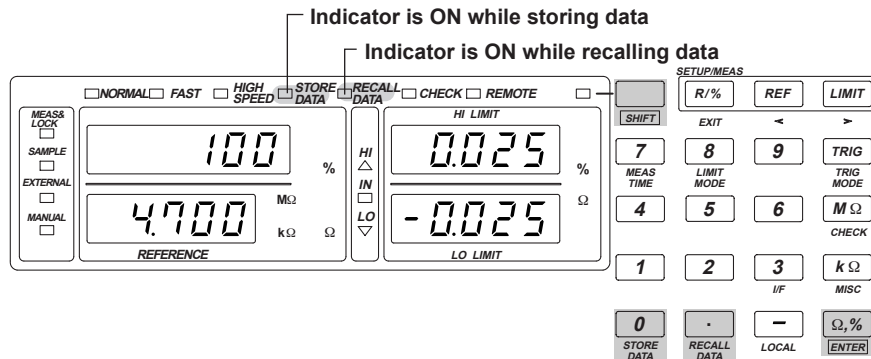

Procedure

The items that are specified or selected are confirmed when the ENTER (Ω ,%) key is pressed. When confirmed, the display returns to the top menu of the SETUP mode. To exit from a menu in the middle of the operation, press the EXIT (R/%) key. The display returns to the top menu of the SETUP mode.

Setting the number of data sets to be stored

1. Press the $\frac{\text{SHIFT}}{\text{STORE DATA}}$ key to switch to the SETUP mode. If the “MEAS & LOCK” indicator is off, this operation is not necessary.

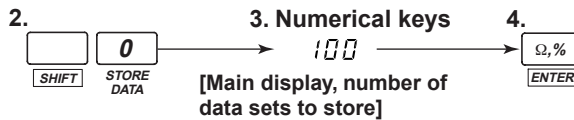

Storing data

1. Pressing the $\frac{\text{SHIFT}}{\text{STORE DATA}}$ key in the measurement mode (“MEAS & LOCK” is ON) causes the “STORE DATA” indicator to turn ON and the instrument to store one data set for every trigger. After storing the specified number of data sets, the store operation terminates and the “STORE DATA” indicator turns OFF.

Aborting the store operation

2. Pressing the $\frac{\text{SHIFT}}{\text{STORE DATA}}$ key while the store operation is in progress aborts the operation and the “STORE DATA” indicator turns OFF. Then, the display returns to the top menu of the SETUP mode.

Recalling data

1. In the SETUP mode, press the $\frac{\text{SHIFT}}{\text{RECALL DATA}}$ key to turn ON the “RECALL DATA” indicator.
2. Press the $\frac{\text{SHIFT}}{\text{RECALL DATA}}$ key to switch to the measurement mode (“MEAS & LOCK” is ON). A data set is recalled every time a trigger occurs. After recalling all stored data, the operation terminates and the “RECALL DATA” indicator turns OFF.

Aborting the recall operation

3. Pressing the $\frac{\text{SHIFT}}{\text{RECALL DATA}}$ key while the recall operation is in progress aborts the operation and the “RECALL DATA” indicator turns OFF.

Note

- Pressing the STORE DATA (SHIFT+0) key in the measurement mode while the store operation is in progress ("STORE DATA" indicator is ON) aborts the operation and continues the measurement.
 - Pressing the RECALL DATA (SHIFT+ .) key while the recall operation is in progress ("RECALL DATA" indicator is ON) aborts the operation and continues the measurement.
-

Explanation

Storing measured data

Up to 2000 measured data sets can be stored in the internal memory. The data are cleared when the power is turned OFF or the settings are initialized. By using the optional Centronics interface, statistics on the stored data can be computed and printed to an external printer. For the procedures related to printing, see section 6.2.

Timing used to store or recall data

When the "STORE DATA" or "RECALL DATA" indicator is ON in the measurement mode, measured data are stored or recalled every time a trigger occurs.

The timing used to store or recall data varies depending on the trigger mode as follows:

EXTERNAL: Data are stored or recalled when a trigger is activated using the input signal at the external trigger input terminal or the number 8 pin of the handler interface.

MANUAL: Data are stored or recalled when the TRIG key is pressed or when a trigger is activated using a communication command.

INTERNAL: Data are stored or recalled at measurement intervals according to the specified measurement time. For details regarding the measurement interval, see page 4-11.

Precautions to be taken when storing data

- The STORE DATA (SHIFT+0) key can be used even in the measurement mode (when the measurement is in progress).
- Executing a store operation, clears the previously stored data.
- Data cannot be stored when the "RECALL DATA" indicator is ON. An error (831) is displayed in this case.
- When the store operation is aborted, data stored up to that point can be recalled.

Precautions to be taken when recalling data

- Data are recalled in order from the first data in the memory. After recalling all of the data, the instrument continues the measurement.
- Data cannot be recalled when the "STORE DATA" indicator is ON. An error (832) is displayed in this case.
- If there are no stored data in the memory, an error (830) is displayed for approximately one second, and the display returns to the top menu of the SETUP mode.

6.2 Printing Data

Keys

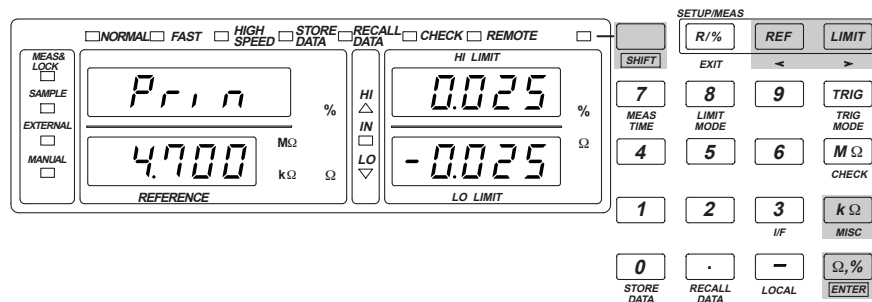

Procedure

The items that are specified or selected are confirmed when the ENTER ($\Omega, \%$) key is pressed. When confirmed, the display returns to the top menu of the SETUP mode. To exit from a menu in the middle of the operation, press the EXIT (R/%) key. The display returns to the top menu of the SETUP mode.

1. Press the $\frac{\text{SETUP/MEAS}}{\text{SHIFT}} \frac{\text{R/\%}}{\text{SHIFT}}$ key to switch to the SETUP mode. If the "MEAS & LOCK" indicator is off, this operation is not necessary.
2. Store the measured data according to the procedures given in section 6.1, "Store/Recall Measured Data."

Selecting whether or not to output the measured data

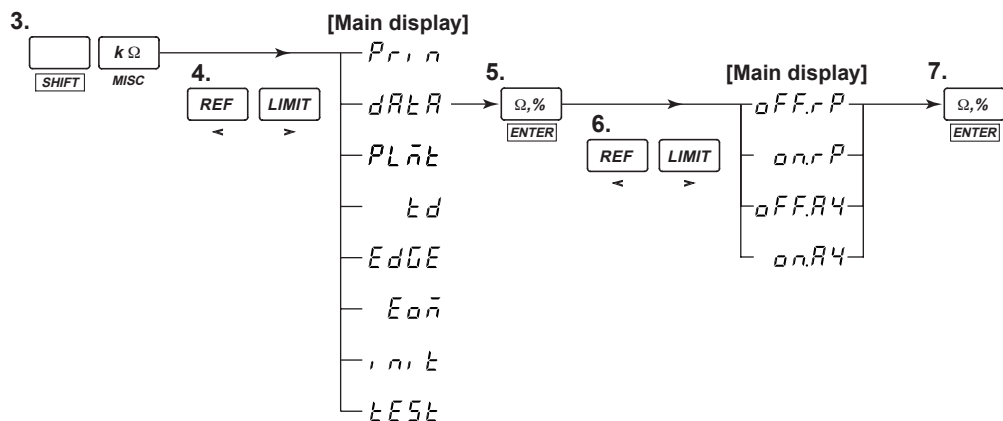

6.2 Printing Data

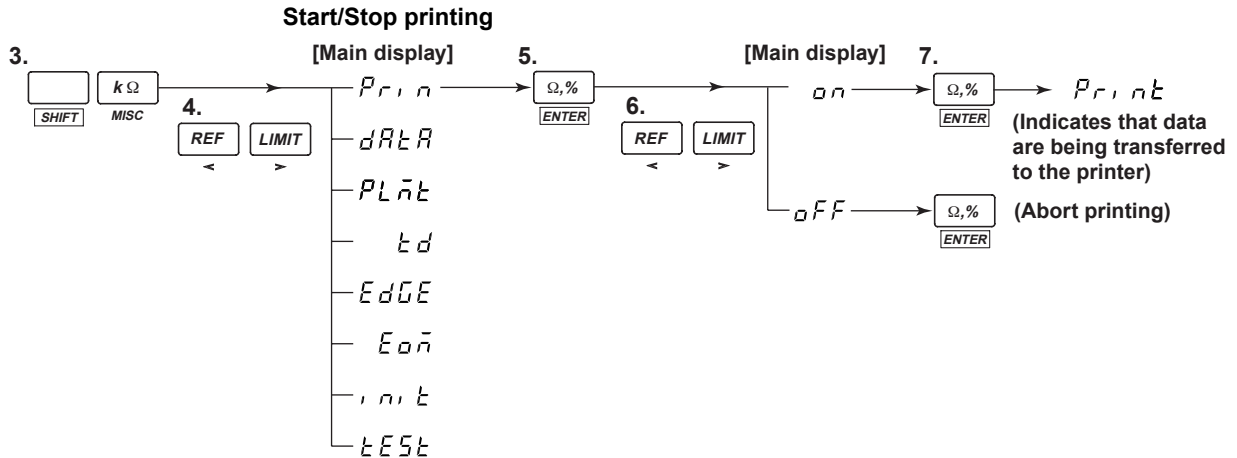

Explanation

By using the optional Centronics interface, statistics on the stored data can be computed and printed to an external printer.

CAUTION

Use a Centronics printer cable to connect an external printer to the instrument. A bad connection can damage the instrument and/or other devices that are connected to it.

Pin arrangement of the Centronics interface connector

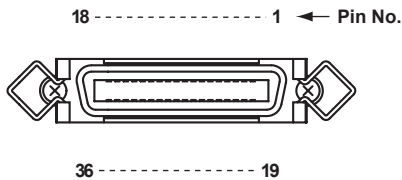

For details, contact your nearest YOKOGAWA dealer.

Pin No.	Signal
1	STROBE (Strobe)
2	DATA0 (Print data bit 0)
...	...
9	DATA7 (Print data bit 7)
10	ACK (Acknowledge)
11	BUSY (Busy)
12	PE (Paper end)
13	SLCT (Select)
14	NC (No connection)
15	NC (No connection)
16	GND (Ground)
17	GND (Ground)
18	NC (No connection)

Pin No.	Signal
19	GND (Ground)
...	...
30	GND (Ground)
31	INIT (Initialize printer)
32	ERROR (Error)
33	GND (Ground)
34	NC (No connection)
35	NC (No connection)
36	NC (No connection)

Output items

Output Items	Description, Limitations
Number of stored data points	
Reference value	Not output when the limit mode is set to absolute (R).
Limit values (LO, HI)	
Comparator result	Frequencies of HI, IN, and LO results
Contact check error	Frequencies of –nC– and –CF– results
Statistics	
Number of valid samples	
Number of invalid samples	Frequencies of oL, nC, and CF results
Max. and min. values of data	
P-P value of data	Maximum value – minimum value
Data average	
Standard deviation of data (σ)	
3σ of data	
Stored measurement data	Select whether or not to output data

Selecting whether or not to output measured data

You can select whether or not to output measured data and the paper size used for printing

- oFF.rP: Print to a paper size (roll paper) on which 40 characters can be printed horizontally and do not output the stored measurement data.
- on.rP: Print to a paper size (roll paper) on which 40 characters can be printed horizontally and output the stored measurement data.
- oFF.A4: Print to an A4 size paper, and do not output the stored measurement data.
- on.A4: Print to an A4 size paper, and output the stored measurement data.

Start/Stop printing

Selecting “on” in the printing start/stop menu starts the print operation. “Print” is displayed while data transfer is in progress.

Selecting “on” in the printing start/stop menu stops the print operation.

Precautions to be taken while printing

- After printing all items, printing is automatically turned OFF.
- To stop printing, set the print setting to OFF. The printing will be aborted.
- An error (830) is displayed when there are no stored data.
- Since printing is done in the SETUP mode, measurements cannot be made while printing.
- The measurement and SETUP modes cannot be switched while printing.
- If the HOLD signal of the handler interface changes to “L” (active) while printing, the instrument aborts the printing operation and starts the measurement.

Note

Statistics are determined on the values that are displayed.

Print example

```

XXXXXXXXXXXXXXXXXXXXXXXXXXXXXXXXXXXXXXXXXXXX
YOKOGAWA
755611 DIGITAL RESISTANCE METER
MEASURED VALUE LIST

STANDARD VALUE : 100.00 kohm
UPPER LIMIT : 0.035 %
LOWER LIMIT : -0.035 %

JUDGE COUNT IN : 42
HI : 5
LO : 43
CONTACT ERROR : 10
TOTAL COUNT : 100

EFF.COUNT : 90
INV.COUNT : 10
MAXIMUM : 0.114
MINIMUM : -0.089
EXTENT : 0.203
AVERAGE : -0.0283
1.SIGMA : 0.04676
3.SIGMA : 0.14029
-----
-0.089:L -0.016:I 0.016:I -0.054:L
-0.089:L -0.016:I 0.016:I -0.054:L
-0.089:L -0.016:I 0.019:I -0.054:L
-0.089:L -0.013:I 0.016:I -0.054:L
-0.089:L -0.013:I 0.016:I -0.057:L
-0.089:L -0.016:I 0.016:I -0.054:L
0.102:H 0.114:H 0.025:I -0.057:L
-0.089:L -0.013:I 0.019:I -0.054:L
-0.086:L -0.013:I 0.057:H -N.C-:
-N.C-: -N.C-: -N.C-: 0.054:H
-0.076:L -0.013:I 0.019:I -0.051:L
-0.086:L -0.010:I 0.019:I -0.054:L
-0.086:L -0.010:I 0.019:I -0.054:L
-0.089:L -0.013:I 0.019:I -0.054:L
-0.089:L -0.013:I 0.016:I -0.057:L
-0.086:L -0.013:I 0.016:I -0.057:L
-0.086:L -0.013:I 0.016:I -0.057:L
-0.086:L -0.013:I 0.016:I -0.054:L
-N.C-: -N.C-: -N.C-: -N.C-:
-N.C-: -N.C-: 0.019:I -0.083:L
-0.079:L -0.003:I 0.022:I -0.057:L
-0.083:L -0.010:I 0.041:H -0.057:L
-0.073:L -0.010:I 0.019:I -0.057:L
-0.083:L -0.010:I 0.019:I -0.060:L
-0.083:L -0.013:I 0.019:I -0.060:L
XXXXXXXXXXXXXXXXXXXXXXXXXXXXXXXXXXXXXXXXXXXX

```

6.3 Initializing the Setup Information

Keys

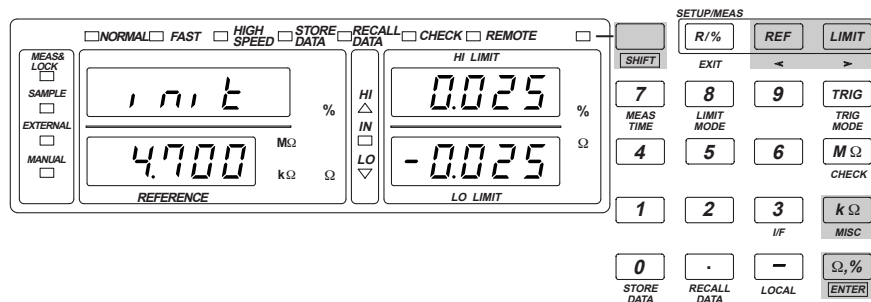

Procedure

Initializing the settings

The items that are specified or selected are confirmed when the ENTER ($\Omega, \%$) key is pressed. When confirmed, the display returns to the top menu of the SETUP mode. To exit from a menu in the middle of the operation, press the EXIT (R/%) key. The display returns to the top menu of the SETUP mode.

1. Press the key to switch to the SETUP mode. If the “MEAS & LOCK” indicator is off, this operation is not necessary.

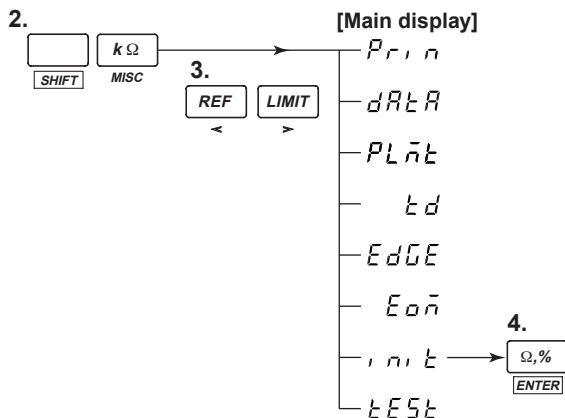

Resetting the instrument to the factory default settings

Turn ON the power switch on the rear panel while pressing the key. Keep pressing the SHIFT key until the top menu appears on the screen.

Explanation

The setup information can be set to “initial settings” or “factory default settings.” This act is called initializing.

Initializing the setup information does not initialize settings related to communications. For details related to the initializing of the setup information, see section 1.4, “A List of Initial Values.”

7.1 Handler Interface Functions and Specifications

Handler Interface Specifications

The types of interface signals are as follows:

- Comparator result output signal (HI, IN, LO)
- Handshaking signal (EXT TRIG, INDEX, EOM)
- Key lock control signal (HOLD)
- Power supply (+12V, COM)

Specifications

Pin No.	Signal	Active Cond.	I/O	Function/Operation
1	HI	L	Output	L when the comparator result is HI
2	IN	L	Output	L when the comparator result is IN
3	LO	L	Output	L when the comparator result is LO
4	NO CONTACT	L	Output	L when a contact check error occurs or when an abnormality is detected in the test current
7	+12 V	—	Output	Power supply
8	EXT TRIG	Specified edge	Input	External trigger signal*1
9	EOM	L	Output	L when the measurement is complete and the comparator result is output*2
10	HOLD	L	Input	Key lock*3
11	INDEX	L	Output	H during trigger input, L when data collection is complete*4
14	COM	—	—	Common

*1 The minimum pulse width is 100 μ s.

*2 The pulse width can be set to 0.1, 5, 10, or 15 ms. The initial setting is 10 ms.

*3 When the signal is in the active state (L), the instrument switches to the measurement mode regardless of the mode it is currently in (the trigger mode is set to EXTERNAL), and makes measurements. In addition, all keys other than the R/% and STORE DATA keys are disabled (key lock). When the signal changes from L to H, all keys are enabled. Thus, you can press the SETUP/MEAS key to switch to the SETUP mode.

*4 When the contact check (after measurement) is enabled, this signal is set to L when the contact check completes.



CAUTION

- The maximum common-mode voltage across the case and each input/output terminal (pin) is ± 42 V peak. Applying a voltage that exceeds this level can damage the instrument.
- Do not apply a voltage that exceeds the maximum input voltage (+12 V) to the input terminal (pin).
Do not connect a load to the output terminal (pin) that would cause the maximum load current (25 mA) to be exceeded. Do not apply a voltage that exceeds the maximum load voltage (30 V) to the output terminal (pin).
Do not connect a load to the power terminal that would cause the maximum load current (50 mA) to be exceeded.
In all of the previous cases, non-compliance with the specifications can damage the instrument.
- Do not apply a negative voltage to the input and output terminals (pins) with respect to the common signal (COM). Doing so can damage the instrument.

Note

To minimize the influence from electro-magnetic interference, use a shielded cable for making connections. In addition, connect the cable's shield to the connector case of the cable.

Output Signal Behavior

The behavior of the INDEX, EOM, NO CONTACT, HI, IN, and LO output signals varies depending on the trigger mode as follows:

When the trigger mode is set to **EXTERNAL**

- INDEX: The signal is generated (set to L) when a trigger occurs, regardless of the measurement result.
- EOM: The signal is generated (set to L) when the measurement completes once, regardless of the measurement result.
- NO CONTACT: The signal is generated (set to L) when the measurement results in a contact check error (nC) or when the test current is abnormal (CF).
- HI: The signal is generated (set to L) when the comparator result of the measured value is HI.
The signal is also generated (set to L) when the measurement results in over-range (oL), contact check error (nC), or when the test current is abnormal (CF).
- IN: The signal is generated (set to L) when the comparator result of the measured value is IN.
- LO: The signal is generated (set to L) when the comparator result of the measured value is LO.

When the trigger mode is set to **MANUAL or INTERNAL**

- INDEX: The signal is not generated (stays at H).
- EOM: The signal is not generated (stays at H).
- NO CONTACT: The signal is generated (set to L) when the measurement results in a contact check error (nC) or when the test current is abnormal (CF).
- HI: The signal is generated (set to L) when the comparator result of the measured value is HI.
The signal is also generated (set to L) when the measurement results in over-range (oL), contact check error (nC), or when the test current is abnormal (CF).
- IN: The signal is generated (set to L) when the comparator result of the measured value is IN.
- LO: The signal is generated (set to L) when the comparator result of the measured value is LO.

Pin Arrangement, Shape

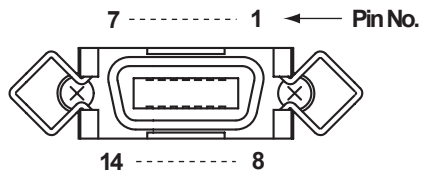

For details, contact your nearest YOKOGAWA dealer.

Input Circuit (Isolated)

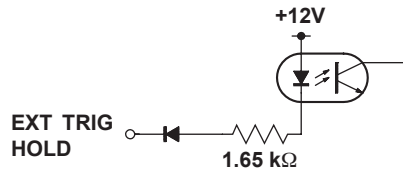

Output Circuit (Isolated)

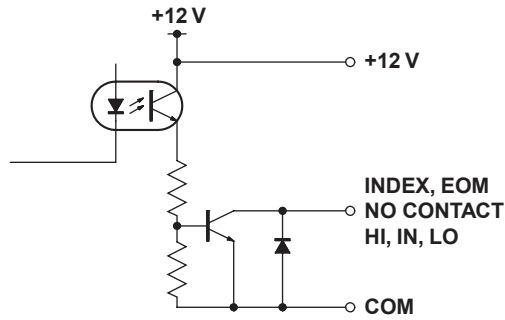

7.2 Setting the Pulse Width of the EOM Signal

Keys

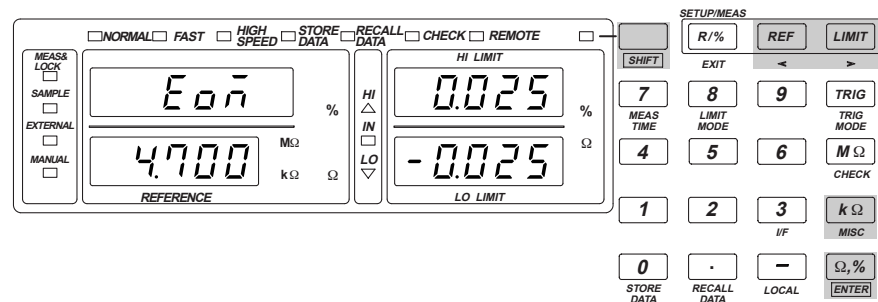

Procedure

The items that are specified or selected are confirmed when the ENTER ($\Omega, \%$) key is pressed. When confirmed, the display returns to the top menu of the SETUP mode. To exit from a menu in the middle of the operation, press the EXIT (R/%) key. The display returns to the top menu of the SETUP mode.

1. Press the $\frac{\text{SETUP/MEAS}}{\text{SHIFT R/\%}}$ key to switch to the SETUP mode. If the "MEAS & LOCK" indicator is off, this operation is not necessary.

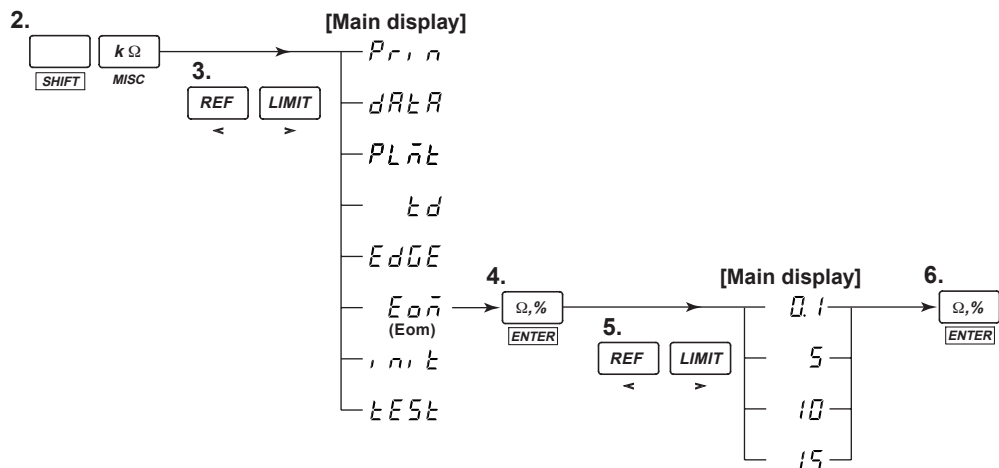

Explanation

The measurement time is the time elapsed from the trigger input to the falling edge of the EOM signal.

The pulse width of the EOM signal (from the falling edge to the rising edge) can be selected from the following choices.

0.1 ms, 5 ms, 10 ms, 15 ms

7.3 Timing Chart

The measurement timing varies depending on the trigger mode, contact check, and other settings.

The timing chart when the trigger mode is set to EXTERNAL (external trigger) is shown below.

When the contact check is OFF

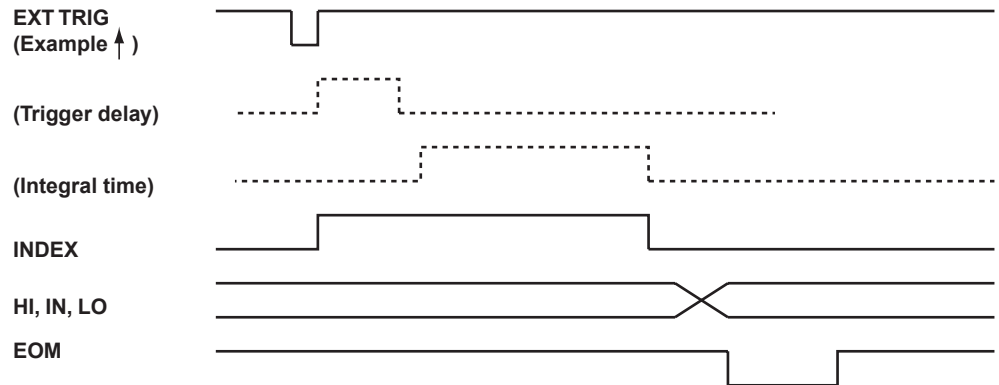

When the contact check is ON (before measurement)

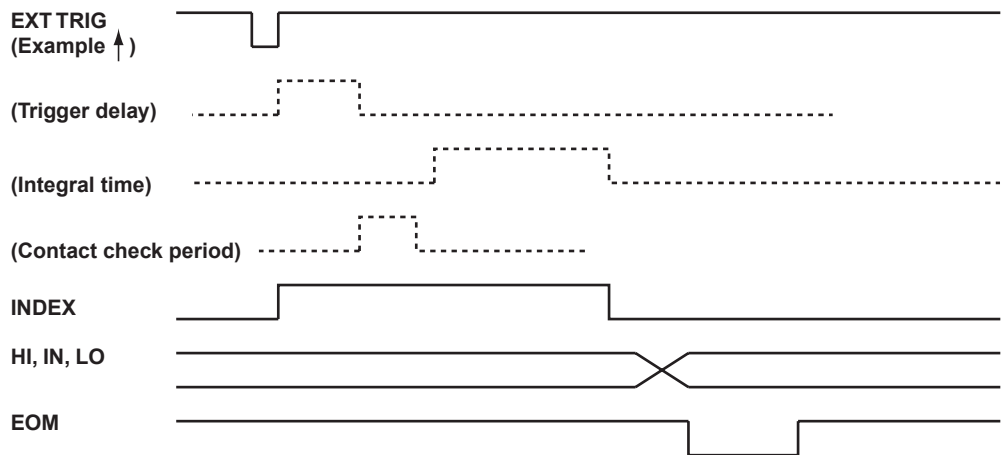

7.3 Timing Chart

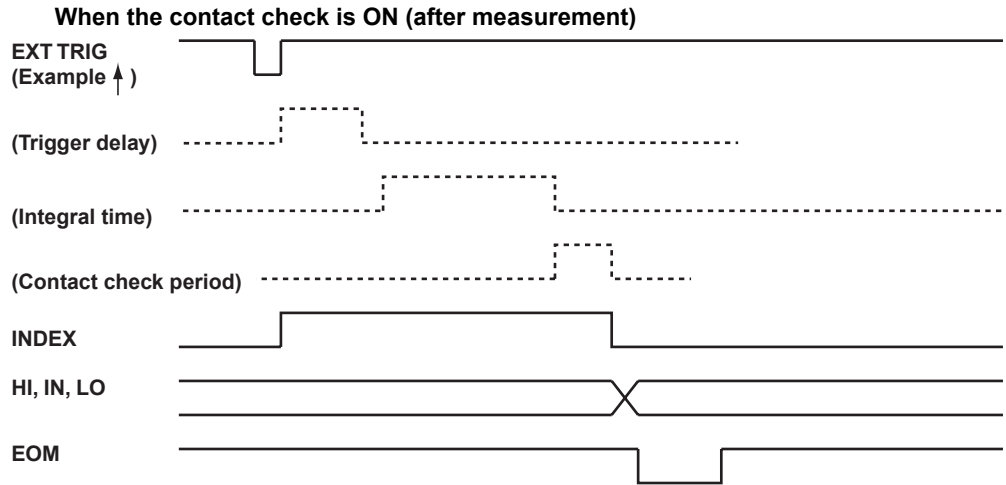

8.1 Serial (RS-232) Interface Functions and Specifications

Receiving Function

All of the parameters that you set with the panel keys can be set through the serial interface except turning the power switch ON/OFF and setting the communication parameters. Output requests for measured/statistical data, setup information, and error codes can be also be received through the serial interface.

Sending Function

Measured/statistical data can be output.
Setup information and status byte can be output.
Error codes that have occurred can be output.

RS-232 Interface Specifications

Electrical, mechanical characteristics:	Conforms to the EIA-574 standard (for the 9-pin interface of the EIA-232 (RS-232) standard)
Connection:	Point-to-point
Communication:	Full-duplex
Synchronization:	Start-stop synchronization
Baud rate:	1200, 2400, 4800, 9600, 19200
Start bit:	1 bit (fixed)
Data length:	7 or 8 bits
Parity:	Even, odd, none
Stop bit:	1 or 2 bits
Connector:	For details contact your nearest YOKOGAWA dealer.
Hardware handshaking:	User can select whether to fix the CA and CB signals to TRUE or use the signal for flow control.
Software handshaking:	User can select whether to use the X-ON and X-OFF signals to control only the transmitted data or both transmitted and received data. X-ON (ASCII 11H) X-OFF (ASCII 13H) Received buffer size: 256 bytes

Switching between Remote and Local Modes

When switching from local to remote mode

Receiving a “:COMMunicate:REMOte ON” command from a PC when the instrument is in the local mode causes the instrument to switch to the remote mode.

- The “REMOTE” indicator turns ON.
- All keys other than the LOCAL key are locked.
- The settings that existed in the local mode are maintained even when the instrument switches to the remote mode.

When switching from remote to local mode

Pressing the LOCAL key when the instrument is in the remote mode causes the instrument to switch to the local mode. However, this act produces no result if the “:COMMunicate:LOCKout ON” command has been received from the PC (local lockout condition).

When the “:COMMunicate:REMOte OFF” is received from the PC, the instrument switches to the local mode regardless of the local lockout condition.

- “REMOTE” indicator turns OFF.
- Key operations are enabled.
- The settings that existed in the remote mode are maintained even when the instrument switches to the local mode.

8.2 Connecting the Serial (RS-232) Interface Cable

When connecting this instrument to a PC, make sure the handshaking methods, data transmission rates, and data formats match those selected on the PC. For details, see the following pages. Also, make sure to use interface cables that match the specifications of the instrument.

Connector and Signal Names

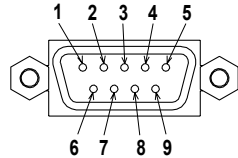

For details contact your nearest YOKOGAWA dealer.

- 2 RD (Received Data): Data received from the PC.
Signal direction: Input
- 3 SD (Send Data): Data transmitted to the PC.
Signal direction: Output
- 5 SG (Signal Ground): Ground for signals.
- 7 RS (Request to Send): Signal used for handshaking when receiving data from the PC.
Signal direction: Output
- 8 CS (Clear to Send): Signal used for handshaking when transmitting data to the PC.
Signal direction: Input

* Pins 1, 4, 6, and 9 are not used.

9-25 Pin Connector and Signal Names

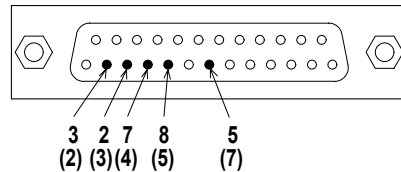

The numbers in parentheses corresponds to the pin numbers on the 25-pin connector.

Signal Direction

The figure below shows the directions of the signals used by the RS-232 interface of this instrument.

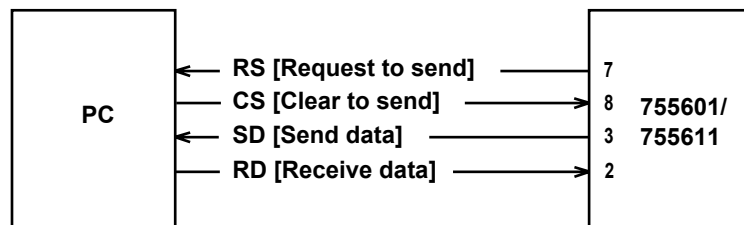

Table of EIA-574 Standard Signals and Their JIS and CCITT Abbreviations

Pin No. (9-pin connector)	Abbreviation			Description
	RS-232	CCITT	JIS	
5	AB (GND)	102	SG	Signal ground
3	BA (TXD)	103	SD	Transmitted data
2	BB (RXD)	104	RD	Received data
7	CA (RTS)	105	RS	Request to send
8	CB (CTS)	106	CS	Clear to send

Connection Examples of Signal Lines

The pin numbers shown are those of 9-pin connectors.

In general, use a cross cable.

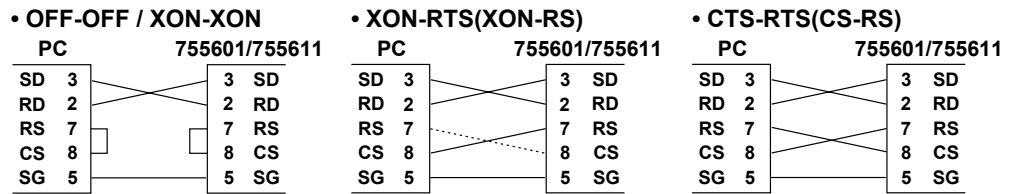

8.3 Handshaking

When using the serial (RS-232) interface for transferring data, it is necessary for equipment on both sides to agree on a set of rules to ensure the proper transfer of data. The set of rules is called handshaking. Because there are many handshaking methods that can be used between the instrument and the PC, one must make sure that the same method is chosen by both the instrument and the PC.

You can choose any of the four methods shown in the following table.

Table of Handshaking Methods (○ indicates that it is supported)

Handshaking method		Data Transmission Control (Control used to send data to a PC)			Data Reception Control (Control used to receive data from a PC)		
		Software handshaking	Hardware handshaking	No handshaking	Software handshaking	Hardware handshaking	No handshaking
	Instrument's menu	Stops transmission when X-OFF is received. Resume when X-ON is received.	Stops transmission when CB(CTS) is false. Resume when it is true.		Send X-OFF when thereceived data buffer is 3/4th filled. Send X-ON when the received data buffer becomes 1/4th filled.	Set CA(RTS) to False when the received data buffer is 3/4th filled. Set to True when the received data buffer becomes 1/4th filled.	
OFF-OFF	HA. 0			○			○
XON-XON	HA. 1	○			○		
XON-RS	HA. 2	○				○	
CS-RS	HA. 3		○			○	

OFF-OFF

Data transmission control

There is no handshaking between the instrument and the PC. The X-OFF and X-ON signals are treated as data, and the CS signal is ignored.

Data reception control

There is no handshaking between the instrument and the PC. When the received buffer becomes full, all overflow data are discarded.

The RS signal is fixed to True.

XON-XON

Data transmission control

Software handshaking is performed between the instrument and the PC. When an X-OFF code is received while sending data to the PC, the instrument stops the data transmission. When it receives the next X-ON code, it resumes the data transmission. The CS signal received from the PC is ignored.

Data reception control

Software handshaking is performed between the instrument and the PC. When the free area of the receive buffer decreases to 64 bytes, the instrument sends an X-OFF code. When the free area increases to 192 bytes, it sends an X-ON code.

The RS signal is fixed to True.

XON-RS**Data transmission control**

Software handshaking is performed between the instrument and the PC. When an X-OFF code is received while sending data to the PC, the instrument stops the data transmission. When it receives the next X-ON code, it resumes the data transmission. CS signal from the PC is ignored.

Data reception control

Hardware handshaking is performed between the instrument and the PC. When the free area of the receive buffer decreases to 64 bytes, the instrument sets "RS=False." When the free area increases to 192 bytes, it sets "RS=True."

CS-RS**Data transmission control**

Hardware handshaking is performed between the instrument and the PC. When the CS signal becomes False while sending data to the PC, the instrument stops the data transmission. When the CS signal becomes True, it resumes the data transmission. X-OFF is treated as data.

Data reception control

Hardware handshaking is performed between the instrument and the PC. When the free area of the receive buffer decreases to 64 bytes, the instrument sets "RS=False." When the free area increases to 192 bytes, it sets "RS=True."

Precautions to be taken with respect to Data Reception Control

When handshaking is used to control the data reception, additional data may be received even when the free area drops below 64 bytes. If the receive buffer becomes full, all overflow data are discarded regardless of the handshaking control. When the free area becomes available again, it will be able to store data once again.

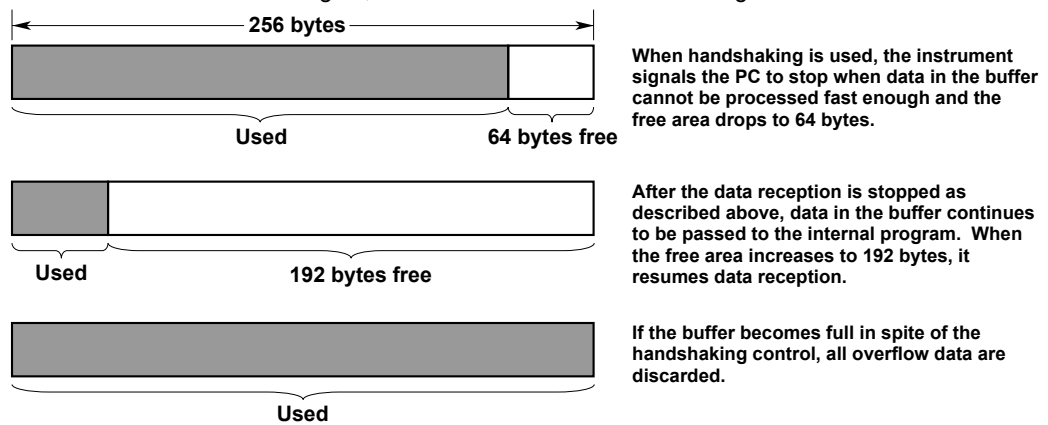
**Data Reception Control using Handshaking****Note**

The program on the PC must be designed so that the receive buffers on the instrument and the PC do not become FULL.

8.4 Data Format

The serial (RS-232) interface on the instrument communicates using start-stop synchronization. With the start-stop synchronization, a start bit is added every time a character is transmitted. The start bit is followed by the data bits, parity bit, and stop bit. (See the figure below.)

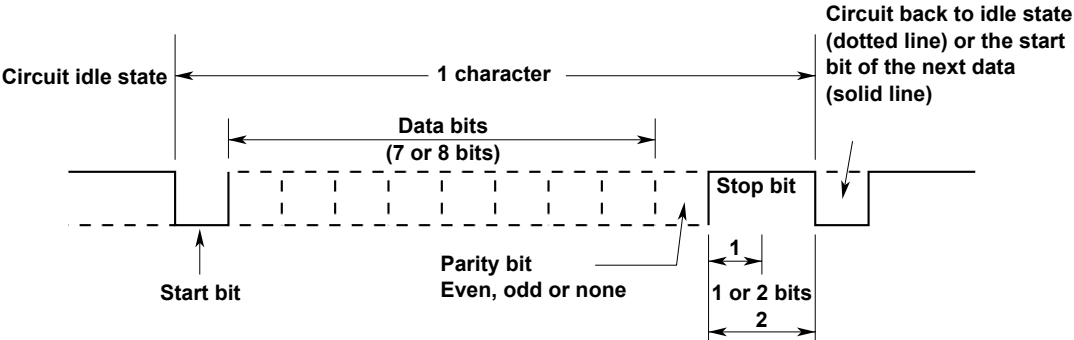

8.5 Serial Communication Settings

Keys

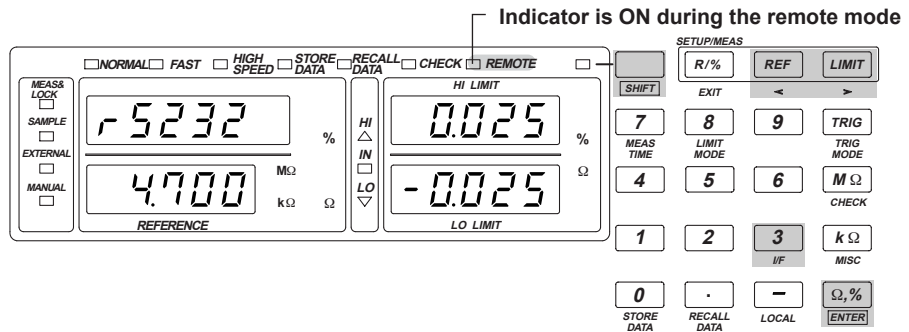

Procedure

The items that are specified or selected are confirmed when the ENTER ($\Omega, \%$) key is pressed. When confirmed, the display returns to the top menu of the SETUP mode. To exit from a menu in the middle of the operation, press the EXIT (R/%) key. The display returns to the top menu of the SETUP mode.

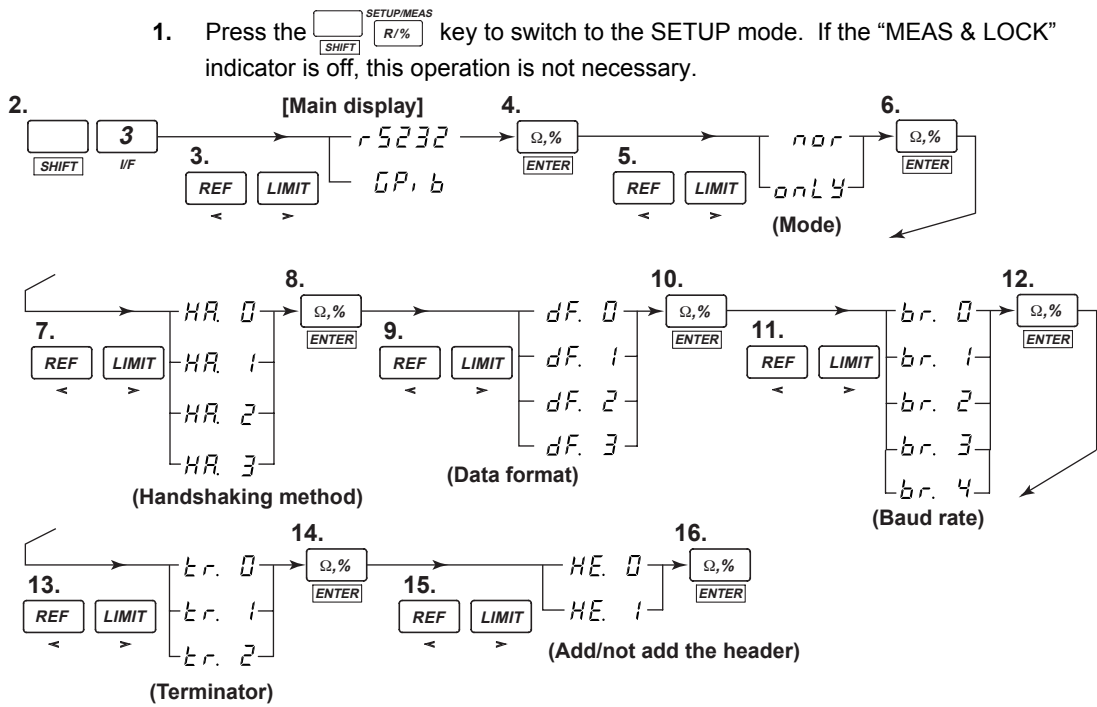

8.5 Serial Communication Settings

Explanation

When you wish to use a PC to set the information that can be specified using the keys on the instrument, or output setup information or measured data to a PC, set the serial interface as follows.

Selecting the mode

Select the mode from the following list of choices.

nor (normal mode): Select this mode when you wish to use a PC to set the information that can be specified using the keys on the instrument, or output setup information or measured data in response to a request from a PC.

onLY (talk-only mode): Select this mode when you wish to output measured data to other devices every time a trigger occurs, not in response to a request from a PC. Settings and output requests received from a PC are ignored.

Selecting the handshaking method

Select the data transmission and reception controls from the following list of choices.

Setting	Handshaking Method
HA. 0	OFF-OFF
HA. 1	XON-XON
HA. 2	XON-RS
HA. 3	CS-RS

Selecting the data format

Select the combination of the data length, parity, and stop bit from the following list of choices.

Setting	Data Length	Parity Bit	Stop Bit
dF. 0	8	None	1
dF. 1	7	Odd	1
dF. 2	7	Even	1
dF. 3	7	None	2

Selecting the baud rate

Select the baud rate from the following list of choices.

Setting	Baud Rate
br. 0	1200
br. 1	2400
br. 2	4800
br. 3	9600
br. 4	19200

Selecting the terminator

Select the terminator that is used when transmitting data from the instrument from the following list of choices. Use "LF" or "CR+LF" for the terminator that is used to receive data on this instrument.

Setting	Terminator
tr. 0	CR+LF
tr. 1	LF
tr. 2	CR

Add or not add the header

Select whether or not to add a header (measurement information) to the measured data that are transmitted. The header includes the comparator result, error information, and the unit of the measured data (% , Ω).

Setting	Header
HE. 0	No header
HE. 1	Add header

9.1 GP-IB Interface Functions and Specifications

GP-IB Interface Functions

Listener function

- All of the information that you set with the panel keys can be set through the GP-IB interface except turning the power switch ON/OFF and setting the communication parameters.
- Receives commands from a controller requesting the output of setup information, measured/statistical data, and other information.
- Also receives status report commands.

Talker function

Outputs setup information, measured/statistical data, and other information.

Talk-only function

Outputs measured data without the need to use a controller. This function is useful when you wish to output data to a printer or a listen-only device.

Note

Listen-only and controller functions are not available on this instrument.

Switching between Remote and Local Modes

When switching from local to remote mode

Receiving a REN (Remote Enable) message from the controller when the instrument is in the local mode causes the instrument to switch to the remote mode.

- The “REMOTE” indicator turns ON.
- All keys other than the LOCAL key are locked.
- The settings that existed in the local mode are maintained even when the instrument switches to the remote mode.

When switching from remote to local mode

Pressing the LOCAL key when the instrument is in the remote mode causes the instrument to switch to the local mode. However, this act produces no result if the instrument has been set to Local Lockout mode (see page 9-4) by the controller.

- “REMOTE” indicator turns OFF.
- Key operations are enabled.
- The settings that existed in the remote mode are maintained even when the instrument switches to the local mode.

9.1 GP-IB Interface Functions and Specifications

GP-IB Interface Specifications

Electrical and mechanical specifications:	Conforms to IEEE St'd 488.1-1987.
Interface Functions:	See the table below.
Protocol:	IEEE St'd 488.2-1992.
Code:	ISO (ASCII) code
Mode:	Addressable mode/Talk-only mode
Address setting:	The address can be set in the range from 0 to 30 using the address setting menu that is displayed with the I/F key (SHIFT+3).
Remote mode clear:	Remote mode can be cleared by pressing the LOCAL key except when the instrument has been set to Local Lockout mode by the controller.

Interface Functions

Functions	Subset Name	Description
Source handshaking	SH1	Full source handshaking capability
Acceptor handshaking	AH1	Full acceptor handshaking capability
Talker	T5	Basic talker capability, serial polling, untalk on MLA (My Listen Address), talk-only capability.
Lister	L4	Basic listener capability, unlisten on MTA, no listen-only capability.
Service request	SR1	Full service request capability
Remote local	RL1	Full remote/local capability
Parallel polling	PP0	No parallel polling capability
Device clear	DC1	Full device clear capability
Device trigger	DT1	Full device trigger capability
Controller	C0	No controller function
Electrical characteristic	E1	Open collector

9.2 Connecting the Interface Cable

GP-IB Cable

The GP-IB connector used on this instrument is a 24-pin connector that conforms to the IEEE St'd 488.1-1987. Use a GP-IB cable that conforms to this standard.

Connection Procedure

Connect the cable as shown below.

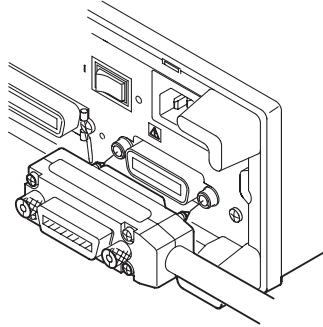

Precautions to be taken when Connecting the Cable

- Firmly tighten the screws on the GP-IB cable connector.
- Multiple devices can be connected using multiple cables. However, no more than 15 devices (including the controller) can be connected to a single bus.
- When connecting multiple devices, each device must have its own unique address.
- Use a cable of length 2 m or less for connecting the devices.
- Make sure the total cable length does not exceed 20 m.
- When communicating, have at least two-thirds of the devices turned ON.
- When connecting multiple devices, connect them in a star or linear configuration (see the diagram below). Loop and parallel configurations are not allowed.

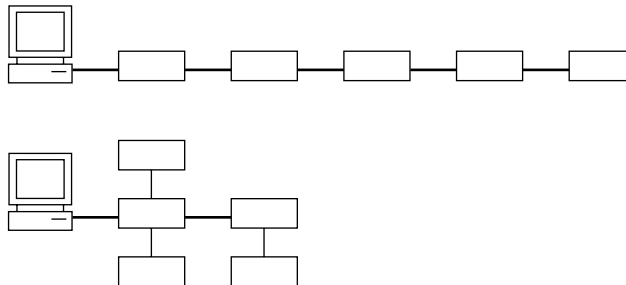

CAUTION

Make sure to turn OFF the PC and the instrument before connecting or disconnecting cables. Otherwise, improper operation and/or damage to the internal circuitry may result.

9.3 Responses to Interface Messages

Responses to Interface Messages

Responses to a uni-line message

IFC(Interface Clear)

Clears the talker and listener functions. Stops output if data are being output.

REN(Remote Enable)

Switches between the remote and local modes.

IDY (Identify) is not supported.

Responses to a multi-line message (address command)

GET(Group Execute Trigger)

Generates a trigger when the trigger mode is set to MANUAL. The operation is the same as the “*TRG” command.

GTL(Go To Local)

Switches to the local mode.

SDC(Selected Device Clear)

- Clears the program message (command) being received and the output queue (see page 10-40).
- The *OPC command and *OPC? query that are in execution are disabled.
- *WAI and COMMunicate:WAIT commands are immediately terminated.

PPC (Parallel Poll Configure) and TCT(Take Control) are not supported.

Responses to a multi-line message (universal command)

LLO(Local Lockout)

Disables the Local key on the front panel to prohibit switching to the local mode.

DCL(Device Clear)

Same operation as the SDC message.

SPE(Serial Poll Enable)

Sets the talker function on all devices on the bus to serial polling mode. The controller polls the devices in order.

SPD(Serial Poll Disable)

Clears the serial polling mode of the talker function on all devices on the bus.

PPU (Parallel Poll Unconfigure) is not supported.

What is an Interface Message

Interface messages are also referred to as interface commands or bus commands. They are commands that are issued by the controller. They are classified as follows.

Uni-line messages

A single control line is used to transmit uni-line messages. The following three messages are available.

IFC (Interface Clear)

IDY (Identify)

REN (Remote Enable)

Multi-line messages

Eight data lines are used to transmit multi-line messages. The messages are classified as follows:

Address commands

These commands are valid when the instrument is designated as a listener or as a talker. The following five commands are available.

Commands that are valid on an instrument that is designated as a listener

- GTL (Go To Local)
- PPC (Parallel Poll Configure)
- SDC (Selected Device Clear)
- GET (Group Execute Trigger)

Commands that are valid on an instrument that is designated as a talker

- TCT(Take Control)

Universal commands

These commands are valid on all instruments regardless of the listener and talker designations. The following five commands are available.

- LLO (Local Lockout)
- DCL (Device Clear)
- PPU (Parallel Poll Unconfigure)
- SPE (Serial Poll Enable)
- SPD (Serial Poll Disable)

In addition, listener address, talker address, and secondary commands are also considered interface messages.

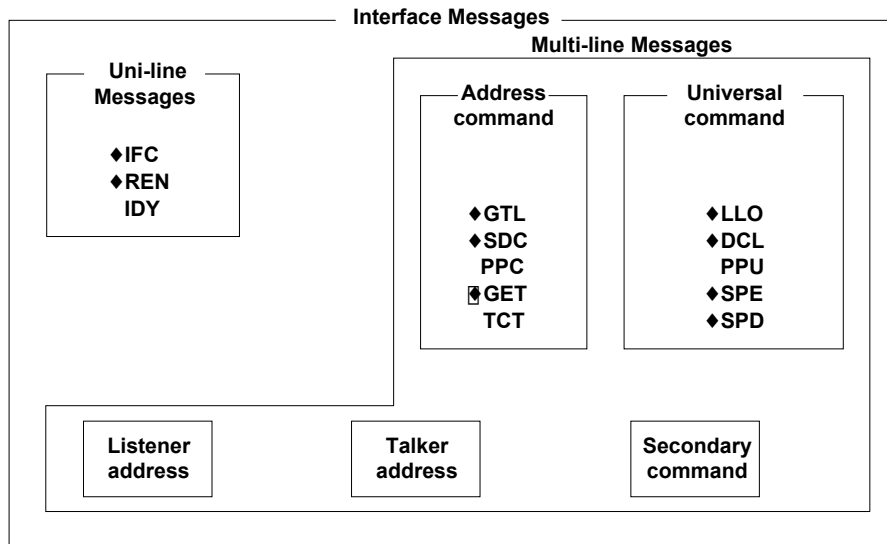

The instrument supports those interface messages that are indicated with “◆” marks.

Note

The differences between SDC and DCL
 Of the multi-line messages, SDC messages are those that require talker or listener designation and DCL messages are those that do not require the designation. Therefore, SDC messages are directed at a particular instrument while DCL messages are directed at all instruments on the bus.

9.4 Switching to the Addressable Mode

Keys

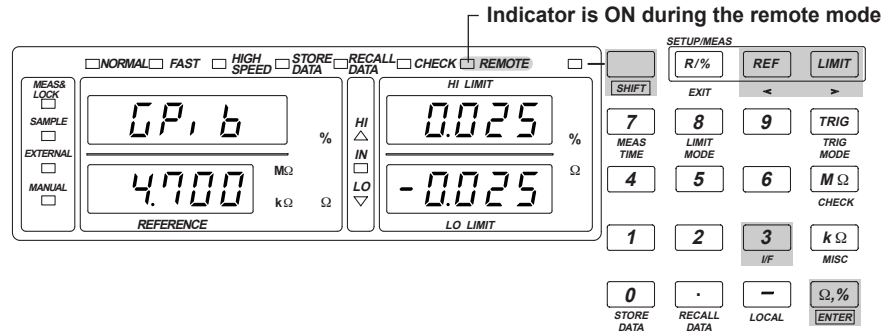

Procedure

The items that are specified or selected are confirmed when the ENTER ($\Omega, \%$) key is pressed. When confirmed, the display returns to the top menu of the SETUP mode. To exit from a menu in the middle of the operation, press the EXIT (R/%) key. The display returns to the top menu of the SETUP mode.

1. Press the key to switch to the SETUP mode. If the "MEAS & LOCK" indicator is off, this operation is not necessary.
2. → [Main display] $r5232$
 3. → $0P.6$
 4. → $\Omega, \%$
 5. → Adr (only) (Mode)
 6. → $\Omega, \%$
7. → $Ad.0$ (Address)
8. → $\Omega, \%$
9. → $HE.0$ (Add/not add the header)
10. → $\Omega, \%$

Explanation**Switching to the addressable mode**

Select "Adr" in the mode selection menu.

Switch to the addressable mode if you wish to use the controller to set the information that you would normally use the panel keys to set or when outputting setup information or measured data to the controller.

Setting the address

Set the instrument's address for the addressable mode in the following range:

0 to 30

Each device that is connected via GP-IB has its own unique address. This address is used for identification. Therefore, make sure to assign a unique address to the instrument when connecting to a PC.

Add or not add the header

Select whether or not to add a header (measurement information) to the measured data that are transmitted.

The header includes the comparator result, error information, and the unit of the measured data (% , Ω).

Setting	Header
HE. 0	No header
HE. 1	Add header

Note

Do not change the address while the controller or other devices are using the GP-IB interface.

9.5 Switching to the Talk-only Mode

Keys

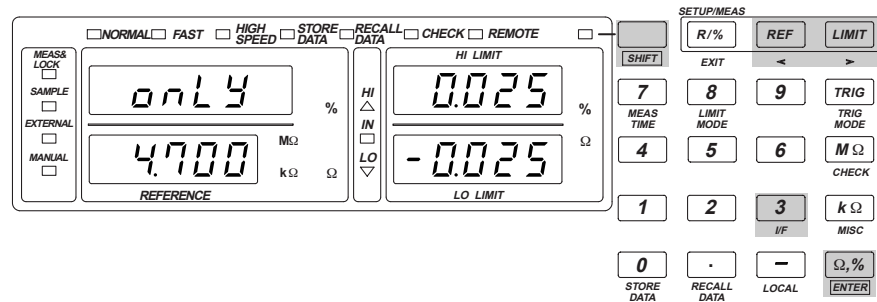

Procedure

The items that are specified or selected are confirmed when the ENTER ($\Omega, \%$) key is pressed. When confirmed, the display returns to the top menu of the SETUP mode. To exit from a menu in the middle of the operation, press the EXIT (R/%) key. The display returns to the top menu of the SETUP mode.

Switching to the SETUP mode

1. Press the key to switch to the SETUP mode. If the “MEAS & LOCK” indicator is off, this operation is not necessary.
2. Set the device that is to receive the measured data to listen-only mode.

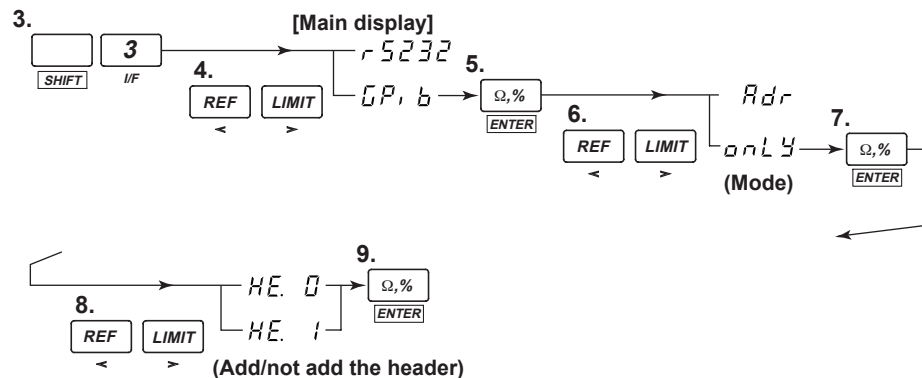

10. Press the key to switch to the measurement mode. The “MEAS & LOCK” indicator turns ON.

The measured data are output every time a measurement is made after the trigger occurrence. The output data format is the same as the response to a “:READ?” query. For details, see section 10.2.12, “Read Group.”

Explanation

Talk-only mode

Select “onLY” in the mode selection menu.

This mode is used to simply transmit data to other devices. It does not need to receive a talker designation in order to transmit data.

It does not accept commands from the controller.

10.1 Before Programming

The communication commands used by this instrument are based on the IEEE488.2 Standard. However, SCPI (Standard Commands for Programmable Instruments) is not supported.

10.1.1 Messages

Messages

Messages are used to exchange information between the controller and the instrument. Messages that are sent from the controller to the instrument are called program messages and messages that are sent back from the instrument to the controller are called response messages.

If a program message contains a message unit that requests a response (a query), the instrument returns a response message upon receiving the program message. One response message is always returned for one program message.

Program Messages

The program message format is shown below.

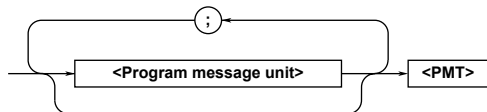

<Program message unit>

A program message consists of zero or more program message units; each unit corresponds to one command. The instrument executes the received commands in order.

Each program message unit is separated by a semicolon (;). For details regarding the format of the program message unit, see the next section.

Example `:CHECK:MODE BEFore;LEVeL 5<PMT>`

Unit
Unit

<PMT>

PMT is a program message terminator. The following three types of terminators are available.

NL (New Line): Same as LF (Line Feed). ASCII code "0AH"

^END: The END message as defined in the IEEE488.1.
(The data byte that is sent with the END message will be the last data of the program message.)

NL^END: NL with an END message attached.
(NL is not included in the program message.)

Program message unit format

The program message unit format is shown below.

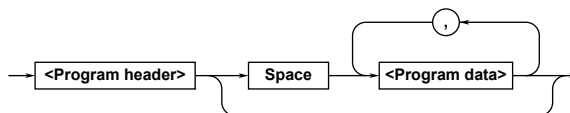

<Program header>

The program header indicates the command type. For details, see page 10-3.

<Program data>

If certain conditions are required in executing a command, program data are added. A space (ASCII code "20H") separates the program data from the header. If there are multiple sets of program data, they are separated by commas (,). For details, see page 10-5.

Example `:CHECK:MODE BEFore<PMT>`

Header
Data

10.1 Before Programming

Response Messages

The response message format is shown below.

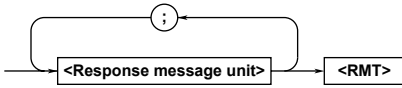

<Response message unit>

A response message consists of one or more response message units; each response message unit corresponds to one response.

Response message units are separated by a semicolon (;).

For details regarding the format of the response message unit, see the section "Response message unit format."

```
:CHECK:MODE BEFORE;LEVEL 5<RMT>
```

Unit
Unit

<RMT>

<RMT> is a response message terminator. It is NL^END.

Response message unit format

The response message unit format is shown below.

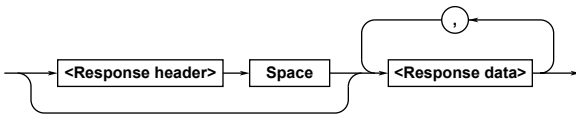

<Response header>

A response header sometimes precedes the response data. A space (ASCII code "20H") separates the data from the header. For details, see page 10-4.

<Response data>

Response data contain the content of the response. If there are multiple sets of response data, they are separated by commas (.). For details, see page 10-5.

```
1.00824E+05<RMT> :CHECK:MODE BEFORE<RMT>
```

Data
Header
Data

If there are multiple queries in a program message, responses are made in the same order as the queries. In most cases, one query returns one response message unit, but there are a few queries that return multiple units. The first response message unit always corresponds to the first query, but the nth response unit may not necessarily correspond to the nth query. Therefore, if you want to make sure that every response is extracted, divide the program messages into individual messages.

Precautions to be Taken When Transferring Messages

- If a program message that does not contain a query is sent, the next program message can be sent at any time.
- If a program message that does contain a query is sent, a response message must be received before the next program message can be sent. If the next program message is sent before the response message is received in its entirety, an error occurs. The response message that was not received is discarded.
- If the controller tries to receive a response message when there is none, an error occurs. If the controller tries to receive a response message before the transmission of the program message is complete, an error occurs.
- If a program message containing multiple message units is sent, and the message contains incomplete units, the instrument will attempt to execute the ones that are believed to be complete. However, these attempts may not always be successful. In addition, if the message contains queries, the responses may not be returned.

Deadlock

The instrument can store in its buffer program and response messages of length 1024 bytes or more (The number of available bytes varies depending on the operating conditions). When both the transmit and receive buffers become full at the same time, the instrument can no longer continue to operate. This state is called a deadlock. In this case, operation can be resumed by discarding the program message. Deadlock will not occur if the program message (including the <PMT>) is kept below 1024 bytes. Furthermore, deadlock never occurs if a program message does not contain a query.

10.1.2 Commands

Commands

There are three types of commands (program headers) that are sent from the controller to the instrument. They differ in their program header formats.

Common Command Header

Commands that are defined in the IEEE 488.2-1992 are called common commands. The header format of a common command is shown below. An asterisk (*) is always placed in the beginning of a command.

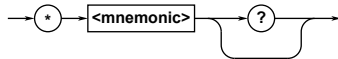

An example of a common command

*CLS

Compound Header

Dedicated commands used by the instrument are classified and arranged in a hierarchy according to their functions. The format of a compound header is shown below. A colon (:) must be used to specify a lower hierarchy.

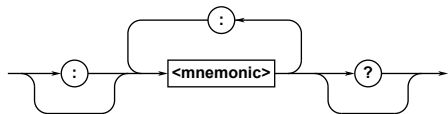

An example of a compound header

:TRIGger:MODE

Simple Header

These commands are functionally independent and do not have a hierarchy. The format of a simple header is shown below.

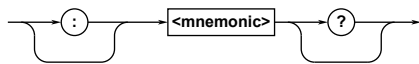

An example of a simple header

:Measure

Note

A <mnemonic> is a character string made up of alphanumeric characters.

When Concatenating Commands

• Command Group

A command group is a group of commands that have the same compound header. A command group may contain sub-groups.

Example Group of commands related to the trigger

```
:TRIGger:DElay
:TRIGger:EDGE
:TRIGger:MODE
```

• When Concatenating Commands of the Same Group

The instrument stores the hierarchical level of the command that is currently being executed, and performs analysis on the assumption that the next command sent will also belong to the same level. Therefore, common header sections can be omitted for commands belonging to the same group.

Example

```
:TRIGger:MODE EXTerna1;DElay0<PMT>
```

• When Concatenating Commands of Different Groups

If the following command does not belong to the same group, a colon (:) is placed in front of the header.

Example

```
:TRIGger:MODE EXTerna1;:MTIME NORMa1<PMT>
```

• When Concatenating Common Commands

Common commands that are defined in the IEEE 488.2-1992 are independent of hierarchy. Colons (:) are not needed before a common command.

Example

```
:TRIGger:MODE EXTerna1;*CLS;DElay 0<PMT>
```

• When Separating Commands with <PMT>

If a terminator is used to separate two commands, each command is a separate message. Therefore, the common header must be specified for each command even when commands belonging to the same command group are being concatenated.

Example

```
:TRIGger:MODE EXTerna1<PMT>:TRIGger:
DElay 0<PMT>
```

10.1 Before Programming

Upper-level Query

An upper-level query is a query in which a question mark (?) is appended to the highest level command of a group. Execution of an upper-level query allows all settings that can be specified in the group to be received at once. Some query groups which are comprised of more than three hierarchical levels can output all the lower level settings.

```
Example : LIMit?<PMT>->:LIMIT:MODE PCNT;PCNT:
        REFERENCE 1.0000E+05;PLIMIT 9.99;
        DATA 5.00,-5.00
```

The response to an upper-level query can be transmitted as a program message back to the instrument. In this way, the settings that existed when the upper-level query was made can be restored. However, some upper-level queries will not return setup information that is not currently in use. It is important to remember that not all the group's information is necessarily returned as part of a response.

Header Interpretation Rules

The instrument interprets the header that is received according to the following rules.

- Upper-case and lower-case letters of a mnemonic are treated the same.
Example "HEADer" can also be written as "header" or "Header."
- The lower-case section of the header can be omitted.
Example "HEADer" can also be written as "HEADE" or "HEAD."
- The question mark (?) at the end of a header indicates that it is a query. The question mark (?) cannot be omitted.
Example The shortest abbreviation for "HEADer?" is "HEAD?."
- If the <x> (value) at the end of a mnemonic is omitted, it is interpreted as a 1.
Example If "FILTer<x>" is written as "FILT," it means "FILTer1."
- The section enclosed by braces ([]) can be omitted.
Example LIMit[:MODE] can be written as "LIM."
However, the last section enclosed by braces ([]) cannot be omitted in an upper-level query.
Example "LIMit?" and "LIMit:MODE?" are different queries.

10.1.3 Responses

When the controller sends a message unit that has a question mark (?) in its program header (query), the instrument returns a response message to the query. A response message is returned in one of the following two forms.

- Response consisting of a header and data
If the response can be used as a program message without any change, it is returned with a command header attached.
Example
:CHECK:MODE?<PMT>->:CHECK:MODE BEFORE<RMT>
- Response consisting of data only
If the response cannot be used as a program message unless changes are made to it (query-only command), only the data section is returned. However, there are query-only commands that return responses with the header attached.
Example
:STATus ERRor?<PMT>->0,"NO ERROR"

When you wish to return a response without a header

Responses that return both header and data can be set so that only the data section is returned. Use the "COMMunicate:HEADer" command for this task.

Abbreviated form

The response header is normally returned with the lower-case section removed. You can change this so that the response header is in the full form. Use the "COMMunicate:VERBose" command for this task. The sections enclosed by braces ([]) are also omitted in the abbreviated form.

10.1.4 Data

Data

Data contain conditions and values that are written after the header. A space is used to separate the header and data. Data are classified as follows.

Data	Description
<Decimal>	Value expressed as a decimal number (Example: The number of measured data to be stored →:STORe:COUnT 1000)
<Resistance><Time>	Physical value (Example: Reference value→:LIMit:PCNT:REFEreNce 100KOHM)
<Register>	Register value expressed as either binary, octal, decimal or hexadecimal. (Example: Extended event register value →:STATUS:EESE #HFE)
<Character data>	Predefined character string (mnemonic). Selectable from { } (Example: Display format of the measured value →:DISPlay[:MODE]{PCNT OHM})
<Boolean>	Indicates ON and OFF. Use "ON," "OFF," or a value. (Example: Set to measurement mode→:MEASure ON)
<Block data>	Arbitrary 8-bit data (Example: Response of the stored measurement data →#6000010ABCDEFGHIJ)

<Decimal>

<Decimal> indicates a value expressed as a decimal number, as shown in the table below. Decimal values are given in the NR form as specified in the ANSI X3.42-1975.

Symbol	Description	Example
<NR1>	Integer	125 —1 +1000
<NR2>	Fixed point number	125.0 —.90 +001.
<NR3>	Floating point number	125.0E+0 —9E—1 +.1E4
<NRf>	Any of the forms <NR1> to <NR3> is allowed.	

- The instrument can receive decimal values that are sent from the controller in any of the forms, <NR1> to <NR3>. This is represented by <NRf>
- For response messages that the instrument returns to the controller, a specific form is defined for each query. The same form is used regardless of the size of the value.
- For the <NR3> format, the "+" sign after the "E" can be omitted. However, the "-" sign cannot be omitted.
- If a value outside the setting range is entered, the value will be changed to the closest value inside the range.
- If a value has more significant digits than the available resolution, the value is rounded. In addition, for some commands, mnemonics such as MAX and MIN can be used as a value.
- For details regarding the resolution and the possible mnemonics that can be used, see the syntax of each command in section 10.2.

<Resistance>, <Time>

<Resistance> and <Time> indicate decimal values that have physical dimensions. <Multiplier> or <Unit> can be attached to the <NRf> format that was described earlier. Enter these using any of the following forms.

Form	Example
<NRf><Multiplier><Unit>	5KOHM
<NRf><Unit>	5E+3OHM
<NRf><Multiplier>	5K
<NRf>	5E+3

• <Multiplier>

<Multipliers> given in the following table can be used.

Symbol	Prefix	Multiplier
EX	Exa	10 ¹⁸
PE	Peta	10 ¹⁵
T	Tera	10 ¹²
G	Giga	10 ⁹
MA	Mega	10 ⁶
K	Kilo	10 ³
M	Milli	10 ⁻³
U	Micro	10 ⁻⁶
N	Nano	10 ⁻⁹
P	Pico	10 ⁻¹²
F	Femto	10 ⁻¹⁵
A	Ato	10 ⁻¹⁸

• <Unit>

<Unit> given in the following table can be used.

Symbol	Word	Description
OHM	Ohm	Ω (resistance)
S	Second	Time

- <Multiplier> and <Unit> are not case sensitive.
- "U" is used to indicate the micro "μ."
- "MA" is used for Mega to distinguish it from Milli.
- If both <Multiplier> and <Unit> are omitted, the default unit (Ω for resistance, s for time) is used.
- Response messages are returned using the default unit (Ω for resistance, s for time) without the <Multiplier> or <Unit>.

10.1 Before Programming

<Register>

<Register> indicates an integer that can be expressed not only in <Decimal> notation, but also <Hexadecimal>, <Octal>, or <Binary>. <Register> is used when each bit of the value has a particular meaning. It is expressed in one of the following forms.

Form	Example
<NRf>	1
#H<Hexadecimal value made up of the digits 0 to 9 and A to F>	#H0F
#Q<Octal value made up of the digits 0 to 7>	#Q777
#B<Binary value made up of the digits 0 and 1>	#B001100

- <Register> is not case sensitive.
- Response messages are always returned in the <NR1> form.

<Character Data>

<Character Data> are predefined character strings (mnemonic). They are mainly used to indicate options. One of the character strings given in brackets { } is chosen.

The data interpretation is the same as the description given in "Header Interpretation Rules" on page 10-4.

Form	Example
{NORMal FAST HSPeed}	NORMal

- As with the header, the "COMMunicate:VERBose" command can be used to select whether to return the response in the full form or in the abbreviated form.
- The "COMMunicate:HEADer" setting does not affect the <character data>.

<Boolean>

<Boolean> are data that indicate ON or OFF. They are expressed in one of the following forms.

Form	Example
{ON OFF <NRf>}	ON OFF 1 0

When <Boolean> is expressed in the <NRf> form, "OFF" is selected if the rounded integer value is "0," and ON for all other cases.

A response message is always returned with a "1" if the value is ON and "0" if the value is OFF.

<Block data>

<Block data> are data containing arbitrary 8-bit values. <Block data> are only used for response messages on the instrument. The form is as follows.

Form	Example
#N<N-digit decimal value><Data byte string>	#6000010ABCDEFGHJJ

- #N
Indicates that the data are <Block data>. "N" is an ASCII character string number (digits) that indicates the number of bytes of data that follow.
- <N-digit decimal value>
Indicates the number of bytes of data. (Example: 000010=10 bytes)
- <Data byte string>
Indicates the actual data. (Example: ABCDEFGHIJ)
- Data are comprised of 8-bit values (0 to 255). Therefore, the ASCII code "0AH" which indicates "NL" can also be included in the data. Hence, care must be taken on the controller side in handling the data.

10.1.5 Synchronization with the Controller

Sequential and Overlap Commands

There are two types of commands: sequential and overlap commands.

For sequential commands, the execution of the following command does not start until the execution of the current command is completed. For overlap commands, however, the execution of the following command may start before the execution of the current command is completed.

Of the commands that are provided by the instrument, the following command is the only overlap command.

All other commands are sequential commands.

```
:PRINT:EXECute
```

Synchronization with Overlap Commands

“:PRINT:EXECute” is a command that is used to print data to an external printer via the Centronics interface. Since printing can take some time depending on the performance of the external printer or the amount of data that is being printed, it is necessary that a command that aborts the operation, “:PRINT:ABORT,” be executable during the print operation.

For example, if the following program is executed, the instrument will attempt to execute the “:MEAS ON” command before the output to the external printer is completed, and, therefore, an execution error occurs.

```
CMD$ = "PRIN:EXEC" ' Output to an external printer
CALL IBWRT(M7556%, CMD$)
CMD$ = "MEAS ON" ' Switch to the measurement
mode
CALL IBWRT(M7556%, CMD$)
```

In order to keep the following command from executing until the execution of the previously sent overlap command is completed, the following commands are used.

```
*WAI
:COMMunicate:OVERlap
*OPC
*OPC?
```

The use of each command is described in the next section.

Using the *WAI command

```
:
CMD$ = "COMM:OPSE #H2000" ' .....(1)
CALL IBWRT(M7556%, CMD$)
CMD$ = "PRIN:EXEC;*WAI" ' .....(2)
CALL IBWRT(M7556%, CMD$)
CMD$ = "MEAS ON" ' .....(3)
CALL IBWRT(M7556%, CMD$)
```

- (1) Make the completion of the external printer operation subject to the *WAI command.
- (2) Output to the external printer and wait for the operation to complete.
- (3) Switch to the measurement mode.

Using the :COMMunicate:OVERlap command

```
:
CMD$ = "COMM:OVER 0" ' .....(1)
CALL IBWRT(M7556%, CMD$)
CMD$ = "PRIN:EXEC" ' .....(2)
CALL IBWRT(M7556%, CMD$)
CMD$ = "MEAS ON" ' .....(3)
CALL IBWRT(M7556%, CMD$)
```

- (1) Prohibit the overlap operation of the external printer operation.
- (2) Output to the external printer (sequential operation)
- (3) Switch to the measurement mode.

Using the *OPC command

```
:
CMD$ = "COMM:OPSE #H2000" ' .....(1)
CALL IBWRT(M7556%, CMD$)
CMD$ = "*ESE 1;*ESR?" ' .....(2)
CALL IBWRT(M7556%, CMD$)
A$ = SPACE$(8) ' .....(3)
CALL IBRD(M7556%, A$)
CMD$ = "*SRE 32" ' .....(4)
CALL IBWRT(M7556%, CMD$)
CMD$ = "PRIN:EXEC;*OPC" ' .....(5)
CALL IBWRT(M7556%, CMD$)
' (Wait for a service request)
CMD$ = "MEAS ON" ' .....(6)
CALL IBWRT(M7556%, CMD$)
```

- (1) Make the completion of the external printer operation subject to the *OPC command.
- (2) Reflect the OPC bit of the standard event register to the status byte.
- (3) Read the response to the *ESR? query (clear the standard event register).
- (4) Reflect the ESB bit of the status byte register to the generation of the service request.
- (5) Output to the external printer and wait for the OPC bit to be set.
- (6) Switch to the measurement mode.

10.1 Before Programming

Using the *OPC? query

```

:
CMD$ = "COMM:OPSE #H2000" ' .....(1)
CALL IBWRT(M7556%, CMD$)
CMD$ = "PRIN:EXEC;*OPC?" ' .....(2)
CALL IBWRT(M7556%, CMD$)
A$ = SPACE$(8) ' .....(3)
CALL IBRD(M7556%, A$)
CMD$ = "MEAS ON" ' .....(4)
CALL IBWRT(M7556%, CMD$)

```

- (1) Make the completion of the external printer operation subject to the *OPC query.
- (2) Output to the external printer and wait for the operation to complete.
- (3) Read the response to the *OPC? query.
- (4) Switch to the measurement mode.

Synchronization with Non-Overlap Commands

Even for sequential commands, synchronization is sometimes required for non communication-related reasons such as a trigger occurrence.

For example, if the *TRG command is used to generate a trigger from the controller and then store the measured data, there is no need to synchronize with the controller. However, if measured data are to be stored using the external trigger mode, the controller cannot determine when the data store operation is completed. Therefore, synchronization with the controller is required in order to wait for the store operation to complete.

To synchronize with the controller according to the current internal condition of the instrument ("Measurement data store complete," for example), the following commands that support the extended event register are used.

```

:STATus:CONDition?
:STATus:FILTer<x>
:STATus:EESE
:STATus:EESR?
:COMMunicate:WAIT
:COMMunicate:WAIT?

```

The use of each command is explained in the following example in which the measured data are stored or recalled using the external trigger mode.

Using the external event register

```

:
CMD$ = "STOR:COUN 200" ' .....(1)
CALL IBWRT(M7556%, CMD$)
CMD$ = "STOR ON" ' .....(2)
CALL IBWRT(M7556%, CMD$)
'
CMD$ = "STAT:FILT10 FALL" ' .....(3)
CALL IBWRT(M7556%, CMD$)
CMD$ = "STAT:EESE 512" ' .....(4)
CALL IBWRT(M7556%, CMD$)
CMD$ = "STAT:EESR?" ' .....(5)
CALL IBWRT(M7556%, CMD$)
N$ = SPACE$(8)
CALL IBRD(M7556%, N$)
CMD$ = "*SRE 8" ' .....(6)
CALL IBWRT(M7556%, CMD$)
ON PEN GOSUB STEND ' .....(7)
PEN ON ' .....(8)
'
CMD$ = "TRIG:MODE EXT" ' .....(9)
CALL IBWRT(M7556%, CMD$)
CMD$ = "MEAS ON" ' .....(10)
CALL IBWRT(M7556%, CMD$)
LOOP1: ' .....(11)
GOTO LOOP1
'
STEND:
CMD$ = "MEAS OFF" ' .....(12)
CALL IBWRT(M7556%, CMD$)
CMD$ = "REC:DATA?" ' .....(13)
CALL IBWRT(M7556%, CMD$)

```

- (1) Store 200 sets measured data.
- (2) Enter the store start ready state.
- (3) Set the external event register on the falling edge of bit 9 (STR) of the status register.
- (4) Reflect only bit 9 (STR) of the extended event register to the status byte.
- (5) Read the extended event register in order to clear the register.
- (6) Reflect the EES bit of the status byte register to the generation of the service request.
- (7) Specify the destination to jump to when an interrupt occurs.
- (8) Enable the SRQ interrupt.
- (9) Set the trigger mode to external trigger.
- (10) Switch to the measurement mode.
- (11) Wait for the data store operation to complete.
- (12) Exit from the measurement mode.
- (13) Query all the measured data that have been stored.

Using the :COMMunicate:WAIT command

```

:
CMD$ = "STOR:COUN 200" ' .....(1)
CALL IBWRT(M7556%, CMD$)
CMD$ = "STOR ON" ' .....(2)
CALL IBWRT(M7556%, CMD$)
'
CMD$ = "STAT:FILT10 FALL" ' .....(3)
CALL IBWRT(M7556%, CMD$)
CMD$ = "STAT:EESR?" ' .....(4)
CALL IBWRT(M7556%, CMD$)
N$ = SPACE$(8)
CALL IBRD(M7556%, N$)
'
CMD$ = "TRIG:MODE EXT" ' .....(5)
CALL IBWRT(M7556%, CMD$)
CMD$ = "MEAS ON" ' .....(6)
CALL IBWRT(M7556%, CMD$)
CMD$ = "COMM:WAIT #H0200" ' .....(7)
CALL IBWRT(M7556%, CMD$)
'
CMD$ = "MEAS OFF" ' .....(8)
CALL IBWRT(M7556%, CMD$)
CMD$ = "REC:DATA?" ' .....(9)
CALL IBWRT(M7556%, CMD$)
:

```

- (1) Store 200 points of measured data.
- (2) Enter the store start ready state.
- (3) Set the external event register on the falling edge of bit 9 (STR) of the status register.
- (4) Read the extended event register in order to clear the register.
- (5) Set the trigger mode to external trigger.
- (6) Switch to the measurement mode.
- (7) Wait for bit 9 (STR) of the extended event register to get set.
- (8) Exit from the measurement mode.
- (9) Query all the measured data that have been stored.

10.1.6 Programming of Various Functions

This section describes the commands that are used for each function and presents examples showing their use. Use this section as a reference when you are actually programming.

The program examples are written in Microsoft QuickBASIC with AT-GPIB/TNT IEEE488.2 board from National Instruments.

Resetting the Instrument

Use one of the following commands.

```

:PANel:INITialize
*RST

```

```

Example  CMD$ = "*RST"
          CALL IBWRT(M7556%, CMD$)

```

Switching between the SETUP and measurement modes

Use the following command.

```
:MEASure
```

Example 1

Switch to the SETUP mode to change the instrument's settings when making measurements in the measurement mode.

```

CMD$ = "MEAS OFF"
CALL IBWRT(M7556%, CMD$)

```

Example 2

Start measurements in the measurement mode after the settings have been changed.

```

CMD$ = "MEAS ON"
CALL IBWRT(M7556%, CMD$)

```

Selecting the limit mode of the comparator function

Use the following command.

```
:LIMit[:MODE]
```

Example 1

Set the limit mode to deviation (%).

```

CMD$ = "LIM PCNT"
CALL IBWRT(M7556%, CMD$)

```

Example 2

Set the limit mode to absolute (R).

```

CMD$ = "LIM OHM"
CALL IBWRT(M7556%, CMD$)

```

Note

- Changing the limit mode clears the preexisting reference value and limit values.
- Select the limit mode before setting the reference value and limit values.

10.1 Before Programming

Setting and checking the reference value and limit values

When the limit mode is set to deviation (%)

Use the following command.

```
:LIMit:PCNT:REFerence Set the reference value.
:LIMit:PCNT:PLIMit Set the input range
(resolution) of the limit values.
:LIMit:PCNT[:DATA] Set the limit values.
:LIMit:PCNT? Checking the current
comparator settings.
```

Example 1

Set the reference value to 1k Ω , HI limit value to 5%, and LO limit value to -5%.

```
CMD$ = "LIM:PCNT:REF 1KOHM"
CALL IBWRT(M7556%, CMD$)
CMD$ = "LIM:PCNT:PLIM 9.99"
CALL IBWRT(M7556%, CMD$)
CMD$ = "LIM:PCNT 5,-5"
CALL IBWRT(M7556%, CMD$)
```

Example 2

```
CMD$ = "LIM:PCNT?"
CALL IBWRT(M7556%, CMD$)
A$ = SPACE$(100)
CALL IBRD(M7556%, A$)
PRINT A$
```

Note

Changing the percent limit initializes the limit values. Set the percent limit before setting the limit values as shown in Example 1 above.

When the limit mode is set to absolute (R)

Use the following command.

```
:LIMit:OHM[:DATA] Set the limit values.
:LIMit:OHM? Check the current comparator
settings.
```

Example 1

Set the HI limit value to 1.05 Ω , LO limit value to 0.95 Ω .

```
CMD$ = "LIM:OHM 1.05,0.95"
CALL IBWRT(M7556%, CMD$)
```

Example 2

Check the current comparator settings.

```
CMD$ = "LIM:OHM?"
CALL IBWRT(M7556%, CMD$)
A$ = SPACE$(50)
CALL IBRD(M7556%, A$)
PRINT A$
```

Setting the contact check

Use the following command.

```
:CHECK[:MODE]
:CHECK:LEVeL
```

Example

Set the check level to 5 Ω and perform the contact check before the measurement.

```
CMD$ = "CHEC:LEV 5"
CALL IBWRT(M7556%, CMD$)
CMD$ = "CHEC BEF"
CALL IBWRT(M7556%, CMD$)
```

Switching the displayed unit of the measured values

Use the following command.

```
:DISPlay[:MODE]
```

Example

Set the displayed unit of the measured values to absolute notation (R).

```
CMD$ = "DISP OHM"
CALL IBWRT(M7556%, CMD$)
```

Setting the measurement time

Use the following command.

```
:MTIME
```

Example

Set the measurement time to Fast.

```
CMD$ = "MTIM FAST"
CALL IBWRT(M7556%, CMD$)
```

Setting the pulse width of the EOM signal

Use the following command.

```
:HANDler:EOM
```

Example

Set the pulse width of the EOM signal to 10 ms.

```
CMD$ = "HAND:EOM 1E-2"
CALL IBWRT(M7556%, CMD$)
```

Setting the trigger delay

Use the following command.

```
:TRIGger:DELaY
```

Example

Set the trigger delay to 5 ms.

```
CMD$ = "TRIG:DEL 5E-3"
CALL IBWRT(M7556%, CMD$)
```

Setting the trigger edge

Use the following command to set the trigger edge.

```
:TRIGger:EDGE
```

Example

Set the trigger edge to the rising edge.

```
CMD$ = "TRIG:EDGE RISE"
CALL IBWRT(M7556%, CMD$)
```

Setting the trigger

To trigger the measurement from the external controller or by using the trigger function on the instrument, use the following commands.

```
:TRIGger:MODE
:MEASure
*TRG
Group Execution Trigger (GET)
:READ?
```

Example 1

Set the trigger mode to external trigger and trigger the measurement

```
:
CMD$ = "STAT:FILT1 RISE" ' .....(1)
CALL IBWRT(M7556%, CMD$)
CMD$ = "STAT:EESE 1" ' .....(2)
CALL IBWRT(M7556%, CMD$)
CMD$ = "STAT:EESR?" ' .....(3)
CALL IBWRT(M7556%, CMD$)
N$ = SPACE$(8)
CALL IBRD(M7556%, N$)
CMD$ = "*SRE 8" ' .....(4)
CALL IBWRT(M7556%, CMD$)
ON PEN GOSUB AVAIL ' .....(5)
PEN ON ' .....(6)
'
CMD$ = "TRIG:MODE EXT" ' .....(7)
CALL IBWRT(M7556%, CMD$)
CMD$ = "MEAS ON" ' .....(8)
CALL IBWRT(M7556%, CMD$)
LOOP1: ' .....(9)
GOTO LOOP1
'
AVAIL:
CMD$ = "READ?" ' .....(10)
CALL IBWRT(M7556%, CMD$)
D$ = SPACE$(20)
CALL IBRD(M7556%, D$)
PRINT D$
CALL IBRSP(M7556%, SPR%) ' .....(11)
CMD$ = "STAT:EESR?" ' .....(12)
CALL IBWRT(M7556%, CMD$)
CALL IBRD(M7556%, N$)
PEN ON ' .....(13)
RETURN
:
```

- (1) Set the extended event register on the rising edge of bit 0 (DAV) of the status register.
- (2) Reflect only bit 0 (DAV) of the extended event register to the status byte.
- (3) Read the extended event register in order to clear the register.
- (4) Reflect the EES bit of the status byte register to the generation of the service request.
- (5) Specify the destination to jump to when an interrupt occurs.
- (6) Enable the SRQ interrupt.
- (7) Set the trigger mode to external trigger.
- (8) Switch to the measurement mode.
- (9) Wait for the external trigger signal.
- (10) Query the measured data.

- (11) Clear the SRQ line.
- (12) Read the extended event register in order to clear the register.
- (13) Enable the SRQ interrupt once again.

Example 2

Set the trigger to manual trigger and trigger the measurement

```
:
CMD$ = "STAT:FILT1 RISE" ' .....(1)
CALL IBWRT(M7556%, CMD$)
CMD$ = "STAT:EESE 1" ' .....(2)
CALL IBWRT(M7556%, CMD$)
CMD$ = "STAT:EESR?" ' .....(3)
CALL IBWRT(M7556%, CMD$)
N$ = SPACE$(8)
CALL IBRD(M7556%, N$)
CMD$ = "*SRE 8" ' .....(4)
CALL IBWRT(M7556%, CMD$)
ON PEN GOSUB AVAIL ' .....(5)
PEN ON ' .....(6)
'
CMD$ = "TRIG:MODE MAN" ' .....(7)
CALL IBWRT(M7556%, CMD$)
CMD$ = "MEAS ON" ' .....(8)
CALL IBWRT(M7556%, CMD$)
LOOP1: ' .....(9)
V% = 0
CALL IBSRE(BD%, V%)
GOTO LOOP1
'
AVAIL:
CMD$ = "READ?" ' .....(10)
CALL IBWRT(M7556%, CMD$)
D$ = SPACE$(20)
CALL IBRD(M7556%, D$)
PRINT D$
CALL IBRSP(M7556%, SPR%) ' .....(11)
CMD$ = "STAT:EESR?" ' .....(12)
CALL IBWRT(M7556%, CMD$)
CALL IBRD(M7556%, N$)
PEN ON ' .....(13)
RETURN
:
```

- (1) Set the extended event register on the rising edge of bit 0 (DAV) of the status register.
- (2) Reflect only bit 0 (DAV) of the extended event register to the status byte.
- (3) Read the extended event register in order to clear the register.
- (4) Reflect the EES bit of the status byte register to the generation of the service request.
- (5) Specify the destination to jump to when an interrupt occurs.
- (6) Enable the SRQ interrupt.
- (7) Set the trigger mode to manual.
- (8) Switch to the measurement mode.
- (9) Wait for the [TRIG] key to be pressed.
- (10) Query the measured data.
- (11) Clear the SRQ line.
- (12) Read the extended event register in order to clear the register.
- (13) Enable the SRQ interrupt once again.

10.1 Before Programming

Example 3

Set the trigger mode to internal trigger and trigger the measurement

```
:
CMD$ = "TRIG:MODE INT"      ' .....(1)
CALL IBWRT(M7556%, CMD$)
CMD$ = "MEAS ON"           ' .....(2)
CALL IBWRT(M7556%, CMD$)
LOOP1:
CMD$ = "READ?"             ' .....(3)
CALL IBWRT(M7556%, CMD$)
D$ = SPACE$(20)
CALL IBRD(M7556%, D$)
PRINT D$
GOTO LOOP1
:
(1) Set the trigger mode to internal trigger.
(2) Switch to the measurement mode.
(3) Query the measured data.
```

Output Example

```
1.00083E+02
1.00083E+02
1.00083E+02
1.00083E+02
1.00083E+02
1.00082E+02
1.00083E+02
1.00083E+02
1.00081E+02
1.00083E+02
1.00083E+02
1.00082E+02
1.00083E+02
1.00083E+02
1.00083E+02
1.00081E+02
1.00083E+02
```

Example 4

Use the common command *TRG

```
:
CMD$ = "TRIG:MODE MAN"     ' .....(1)
CALL IBWRT(M7556%, CMD$)
CMD$ = "MEAS ON"           ' .....(2)
CALL IBWRT(M7556%, CMD$)
LOOP1:
CMD$ = "*TRG"              ' .....(3)
CALL IBWRT(M7556%, CMD$)
CMD$ = "READ?"             ' .....(4)
CALL IBWRT(M7556%, CMD$)
D$ = SPACE$(20)
CALL IBRD(M7556%, D$)
PRINT D$
GOTO LOOP1
:
(1) Set the trigger mode to manual.
(2) Switch to the measurement mode.
(3) Generate the trigger.
(4) Query the measured data.
```

```
•
•
•
```

Note

QuickBASIC may be interrupted when a GPIB SRQ signal occurs, and possibly go to a user-specified service routine. To intercept SRQ signal interruptions and to make them available to user programs, the NI-488.2 for MS-DOS drivers uses the QuickBASIC "ON PEN" statement.

10.2 Commands

10.2.1 A List of Commands

Command	Function	Page
CHECK Group		
:CHECK?	Queries all settings related to the contact check function.	10-15
:CHECK:LEVel	Sets the contact check level or queries the current setting.	10-15
:CHECK[:MODE]	Turns ON/OFF the contact check function and sets the check timing or queries the current setting.	10-15
COMMunicate Group		
:COMMunicate?	Queries all settings related to communications.	10-16
:COMMunicate:HEADer	Sets whether or not (ON/OFF) to attach a header to the response data or queries the current setting.	10-16
:COMMunicate:LOCKout	Sets local lockout or queries the current setting. (dedicated command for RS-232)	10-16
:COMMunicate:OPSE	Sets the overlap commands that are subject to *OPC, *OPC?, and *WAI or queries the current setting.	10-17
:COMMunicate:OPSR?	Queries the operation pending status register value.	10-17
:COMMunicate:OVERLap	Sets the commands that will operate as overlap commands or queries the current setting.	10-17
:COMMunicate:REMOte	Switches to remote/local mode or queries the current setting. (dedicated command for RS-232)	10-17
:COMMunicate:STATus?	Queries the line status.	10-17
:COMMunicate:VERBoSe	Sets the response messages to full form or abbreviated form or queries the current setting.	10-17
:COMMunicate:WAIT	Waits for a specified extended event.	10-17
:COMMunicate:WAIT?	Creates the response that is returned when the specified event occurs.	10-18
DISPlay Group		
:DISPlay?	Queries all settings related to the measurement display.	10-18
:DISPlay[:MODE]	Sets the displayed unit (deviation (%) or absolute (R)) of the measured value or queries the current setting.	10-18
HANDler Group		
:HANDler?	Queries all settings related to the handler interface.	10-18
:HANDler:EOM	Sets the pulse width of the EOM signal or queries the current setting.	10-18
HEADer Group		
:HEADer	Sets whether or not to attach a header (measurement information) to measured data or queries the current setting.	10-19
LIMit Group		
:LIMit?	Queries all settings related to the limit mode and limit values.	10-20
:LIMit[:MODE]	Sets the limit mode (deviation (%) / absolute (R)) or queries the current setting.	10-20
:LIMit:OHM?	Queries all settings when the limit mode is set to absolute mode (R).	10-20
:LIMit:OHM[:DATA]	Sets the limit values (absolute value (R)) or queries the current setting.	10-20
:LIMit:PCNT?	Queries all settings when the limit mode is set to deviation mode (%).	10-21
:LIMit:PCNT[:DATA]	Sets the limit values (deviation (%)) or queries the current setting.	10-21
:LIMit:PCNT:PLIMit	Sets the percent limit or queries the current setting. (only when the limit mode is set to %)	10-21
:LIMit:PCNT:REFerence	Sets the reference value or queries the current setting. (only when the limit mode is set to %)	10-21
MEASure Group		
:MEASure	Starts or stops the measurement (measurement/SETUP modes) or queries the current setting.	10-22
MTIME Group		
:MTIME	Sets the type of measurement time or queries the current setting.	10-23
PANel Group		
:PANel:INITIalize	Initializes settings.	10-23
PRINt Group		
:PRINt?	Queries all settings related to the printer output.	10-24
:PRINt:ABORt	Aborts printing.	10-24
:PRINt:EXECute	Starts printing.	10-24
:PRINt:FORMat	Sets the contents to be printed (sets whether or not to print measured data) or queries the current setting.	10-24
:PRINt:STATe?	Queries the printer output condition.	10-24

10.2 Commands

Command	Function	Page
READ Group		
:READ?	Queries the measured data.	10-25
RECall Group		
:RECall?	Queries all settings related to the recalling of the measure data.	10-26
:RECall:DATA[:ASCIi]?	Queries the measured data that are stored (ASCII format).	10-26
:RECall:DATA:BINary?	Queries the measured data that are stored (binary format).	10-27
:RECall:RESult?	Queries the statistics related to the stored measured data.	10-27
:RECall[:STATe]	Sets the measured data recall state (ON/OFF) or queries the current setting.	10-28
SELFtest Group		
:SELFtest:KEY	Executes the panel key test.	10-28
:SELFtest:LED	Executes the LED test.	10-28
:SELFtest:HANDler	Executes the handler interface output test.	10-28
STATus Group		
:STATus?	Queries all settings related to the communication status.	10-29
:STATus:CONDition?	Queries the status register.	10-29
:STATus:EESE	Sets the extended event enable register or queries the current setting.	10-29
:STATus:EESR?	Queries the extended event register and clears the register.	10-29
:STATus:ERRor?	Queries the error code and message information (beginning of the error queue).	10-30
:STATus:FILTer<x>	Sets the transition filter or queries the current setting.	10-30
:STATus:QENable	Sets whether or not to store messages other than errors in the error queue or queries the current setting.	10-30
:STATus:QMESsage	Sets whether or not to attach message information to the response to the ":STATus:ERRor?" query or queries the current setting.	10-30
:STATus:SPOLL?	Executes serial polling (dedicated command for RS-232).	10-30
STORe Group		
:STORe?	Queries all settings related to the storing of the measured data.	10-30
:STORe:COUNT	Sets the number of data points to store or queries the current setting.	10-30
:STORe:POINts?	Queries the number of data points that are stored.	10-31
:STORe[:STATe]	Sets the measured data store state (ON/OFF) or queries the current setting.	10-31
TRIGger Group		
:TRIGger?	Queries all settings related to the trigger.	10-32
:TRIGger:DELay	Sets the trigger delay or queries the current setting.	10-32
:TRIGger:EDGE	Sets the trigger edge or queries the current setting.	10-32
:TRIGger:MODE	Sets the trigger mode or queries the current setting.	10-32
Common Command Group		
*CLS	Clears the standard event register, extended event register, and error queue.	10-33
*ESE	Sets the standard event enable register or queries the current setting.	10-33
*ESR?	Queries the standard event register and clears the register.	10-34
*IDN?	Queries the instrument model.	10-34
*LRN?	Queries current group settings.	10-34
*OPC	Sets an OPC event upon the completion of the specified overlap command.	10-34
*OPC?	Creates a response upon the completion of the specified overlap command.	10-34
*OPT?	Queries the installed options.	10-34
*PSC	Sets whether or not to clear the registers at power up or queries the current setting.	10-34
*RST	Initializes the settings.	10-34
*SRE	Sets the service request enable register or queries the current setting.	10-35
*STB?	Queries the status byte register.	10-35
*TRG	Executes a manual trigger.	10-35
*TST?	Performs a self-test and queries the result.	10-35
*WAI	Holds the subsequent command until the completion of the specified overlap operation.	10-35

10.2.2 CHECK(contact CHECK) Group

The commands in the CHECK(contact CHECK) Group deal with the contact check function.

These commands can be used to make the same settings and inquiries as when the CHECK key on the front panel is pressed.

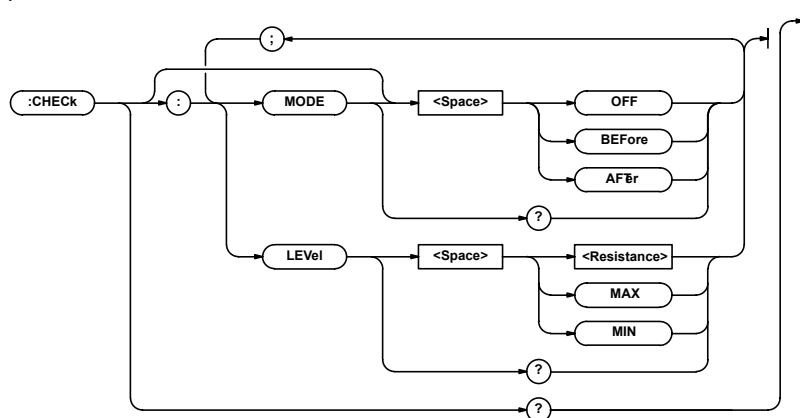

:CHECK?

Function Queries all settings related to the contact check function.

Syntax :CHECK?

Example When contact check is OFF
:CHECK?→:CHECK:MODE OFF
When contact check is ON (BEFore)
:CHECK?→:CHECK:MODE BEFORE;LEVEL 5

:CHECK:LEVEL

Function Sets the contact check level or queries the current setting.

Syntax :CHECK:LEVEL {<Resistance>|MAX|MIN}
:CHECK:LEVEL?
<Resistance> = 1 to 30 Ω (Resolution 1 Ω)
MAX = 30 Ω
MIN = 1 Ω

Response <NR1> form

Example :CHECK:LEVEL 50HM
:CHECK:LEVEL?→:CHECK:LEVEL 5

:CHECK[:MODE]

Function Turns ON/OFF the contact check function and sets the check timing or queries the current setting.

Syntax :CHECK[:MODE] {OFF|BEFore|AFTer}
:CHECK:MODE?
OFF = Contact check: OFF
BEFore = Contact check: ON, check before measurement
AFTer = Contact check: ON, check after measurement

Response {OFF|BEFore|AFTer}

Example :CHECK:MODE OFF
:CHECK:MODE?→:CHECK:MODE OFF

10.2 Commands

10.2.3 COMMunicate Group

The commands in the COMMunicate Group deal with communications.

There are no front-panel keys that correspond to the commands in this group.

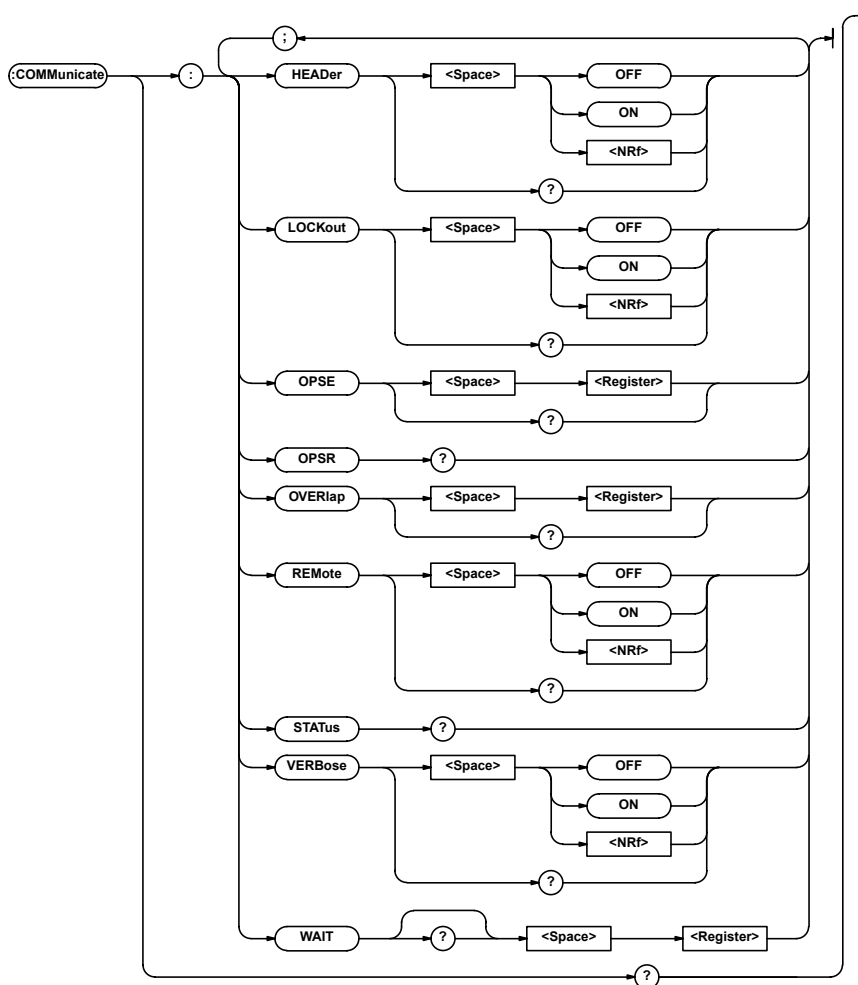

:COMMunicate?

Function Queries all settings related to communications.

Syntax :COMMunicate?

Example :COMMUNICATE?→:COMMUNICATE:HEADER 1;
OPSE 8192;OVERLAP 8192;VERBOSE 1

:COMMunicate:HEADer

Function Sets whether or not (ON/OFF) to attach a header to the response data or queries the current setting.

Syntax :COMMunicate:HEADer {<Boolean>}
:COMMunicate:HEADer?

Response {0|1}

Example :COMMUNICATE:HEADER ON
:COMMUNICATE:HEADER?→:COMMUNICATE:HEADER 1

Description For example, the response data to the “:LIMIT:PCNT:REFERENCE?” query is “:LIMIT:PCNT:REFERENCE 1.0E+05” if the header is attached, and “1.0E+05” if it is not.

:COMMunicate:LOCKout

Function Sets or clears local lockout.

Syntax :COMMunicate:LOCKout {<Boolean>}
:COMMunicate:LOCKout?

Response {0|1}

Example :COMMUNICATE:LOCKOUT ON
:COMMUNICATE:LOCKOUT?
→:COMMUNICATE:LOCKOUT 1

Description This is a dedicated command of the serial (RS-232) interface.

:COMMunicate:OPSE**(Operation Pending Status Enable register)**

Function Sets the overlap commands that are subject to *OPC, *OPC?, and *WAI or queries the current setting.

Syntax :COMMunicate:OPSE <Register>
:COMMunicate:OPSE?
<Register>=0 to 65535 (Operation pending status enable register, see the description of the :COMMunicate:OVERlap command)

Response <NR1>

Example :COMMUNICATE:OPSE 65535
:COMMUNICATE:OPSE?→:COMMUNICATE:OPSE 8192

Description In the above example, all bits are set to “1” so that all overlap commands are subject to *OPC, *OPC?, and *WAI. However, because the bits that are fixed to “0” cannot be changed, only bit 13 shows a “1” when a query is made.

:COMMunicate:OPSR?**(Operation Pending Status Register)**

Function Queries the operation pending status register value.

Syntax :COMMunicate:OPSR?

Response <NR1> (Operation pending status enable register, see the description of the :COMMunicate:OVERlap command)

Example :COMMUNICATE:OPSR?→0

:COMMunicate:OVERlap

Function Sets the commands that will operate as overlap commands or queries the current setting.

Syntax :COMMunicate:OVERlap <Register>
:COMMunicate:OVERlap?
<Register>=0 to 65535 (Overlap enable register, see the diagram below)

Response <NR1>

Example :COMMUNICATE:OVERLAP 65535
:COMMUNICATE:OVERLAP?
→:COMMUNICATE:OVERLAP 8192

Description

- In the above example, all bits are set to “1” so that all overlap commands are enabled. However, because the bits that are fixed to “0” cannot be changed, only bit 13 shows a “1” when a query is made.
- For the procedures regarding the use of the “:COMMunicate:OVERlap” command for synchronization, see page 10-7.
- Operation pending status (enable) register/ overlap enable register

15	14	13	12	11	10	9	8	7	6	5	4	3	2	1	0
0	0	PRN	0	0	0	0	0	0	0	0	0	0	0	0	0

When bit 13 (PRN)=1: External printer output operation incomplete

:COMMunicate:REMOte

Function Switches to remote/local mode or queries the current setting. When the setting is set to ON, it is set to the remote mode.

Syntax :COMMunicate:REMOte {<Boolean>}
:COMMunicate:REMOte?

Response {0|1}

Example :COMMUNICATE:REMOTE ON
:COMMUNICATE:REMOTE?→:COMMUNICATE:REMOTE 1

Description This is a dedicated command of the serial (RS-232) interface.

:COMMunicate:STATus?

Function Queries the line status.

Syntax :COMMunicate:STATus?

Response <NR1>

Example :COMMUNICATE:STATUS?→0

Description • The descriptions of the status bits are as follows.

Bit	RS-232	GP-IB
0	Parity error	Unrecoverable transmission error
1	Framing error	Always 0
2	Break character detected	Always 0
Others	Always 0	Always 0

• When a causing event occurs, the corresponding status bit is set. When the status is read, it is cleared.

:COMMunicate:VERBOse

Function Sets the response messages to full form or abbreviated form or queries the current setting.

Syntax :COMMunicate:VERBOse {<Boolean>}
:COMMunicate:VERBOse?

Response {0|1}

Example :COMMUNICATE:VERBOSE ON
:COMMUNICATE:VERBOSE?
→:COMMUNICATE:VERBOSE 1

Description For example, the response data to the “:TRIGGER:MODE?” query is “:TRIGGER:MODE EXTERNAL” when it is returned in the full form and “:TRIG EXT” when it is returned in the abbreviated form.

:COMMunicate:WAIT

Function Waits for a specified extended event.

Syntax :COMMunicate:WAIT <Register>
<Register>=0 to 65535 (Extended event register, see page 10-39)

Example :COMMUNICATE:WAIT 65535

Description For the procedures regarding the use of the “:COMMunicate:WAIT” command for synchronization, see page 10-9.

10.2 Commands

:COMMunicate:WAIT?

Function	Creates the response that is returned when the specified event occurs.
Syntax	:COMMunicate:WAIT? <Register> <Register>=0 to 65535 (Extended event register, see page 10-39)
Response	1 (Fixed)
Example	:COMMUNICATE:WAIT? 65535→1

10.2.4 DISPlay Group

The commands in the DISPlay Group deal with the measurement display. These commands can be used to make the same settings and inquiries as when the R/% key on the front panel is pressed.

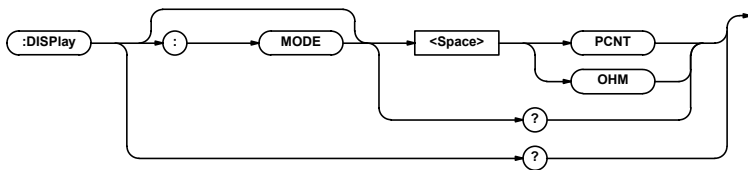

:DISPlay?

Function	Queries all settings related to the measurement display.
Syntax	:DISPlay?
Example	:DISPLAY?→:DISPLAY:MODE PCNT

:DISPlay[:MODE]

Function	Sets the displayed unit (deviation (%) or absolute (R)) of the measured value or queries the current setting.
Syntax	:DISPlay[:MODE] {PCNT OHM} :DISPlay:MODE? PCNT = Deviation (%) display OHM = Absolute (R) display
Response	{PCNT OHM}
Example	:DISPLAY:MODE PCNT :DISPLAY:MODE?→:DISPLAY:MODE PCNT
Description	When the ":LIMit[:MODE]" is set to OHM, this command cannot be used to specify PCNT. Doing so will result in an error (814).

10.2.5 HANDler Group

The commands in the HANDler Group deal with the handler interface. These commands can be used to make the same settings and inquiries as the "Eom" menu accessible through the MISC key on the front panel.

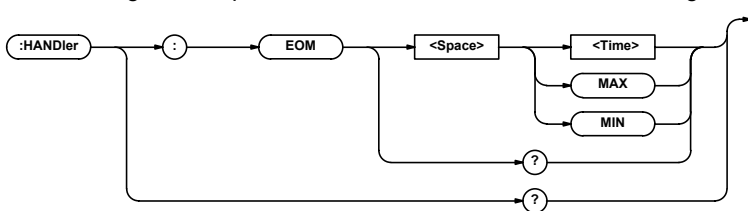

:HANDler?

Function	Queries all settings related to the handler interface output.
Syntax	:HANDler?
Example	:HANDLER?→:HANDLER:EOM 0.0100

:HANDler:EOM

Function	Sets the pulse width of the EOM signal or queries the current setting.
Syntax	:HANDler:EOM {<Time> MAX MIN} :HANDler:EOM? <Time> = 0.1, 5, 10, 15(ms) MAX = 15ms MIN = 0.1ms
Response	{0.0001 0.0050 0.0100 0.0150} (<NR2> form)
Example	:HANDLER:EOM 10MS :HANDLER?Æ:HANDLER:EOM 0.0100

10.2.6 HEADer Group

The commands in the HEADer Group deal with the measurement information when querying the measured data. These commands can be used to make the same settings and inquiries as the “HE. ” menu accessible through the I/F key on the front panel.

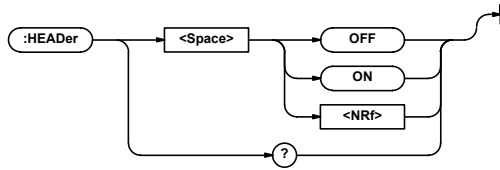

:HEADer

Function	Sets whether or not to attach a header (measurement information) to the measured data or queries the current setting.
Syntax	:HEADer {<Boolean>} :HEADer?
Response	{1 0}
Example	:HEADER ON :HEADER?→:HEADER 1
Description	<ul style="list-style-type: none"> • The “:HEADer” setting is reflected in the following responses and output content. <ul style="list-style-type: none"> :READ? :RECall:DATA[:ASCIi]? :RECall:DATA:BINary? Measured data output in the talk-only mode • When the header is attached, the comparator result, error information, and unit (% , Ω) are also output. This command is different from the “:COMMunicate:HEADer” command.

10.2 Commands

10.2.7 LIMit Group

The commands in the LIMit Group deal with the limit mode and limit values. These commands can be used to make the same settings and inquiries as the “PLmt” menu accessible through the LIMIT MODE, REF, LIMIT, and MISC key on the front panel.

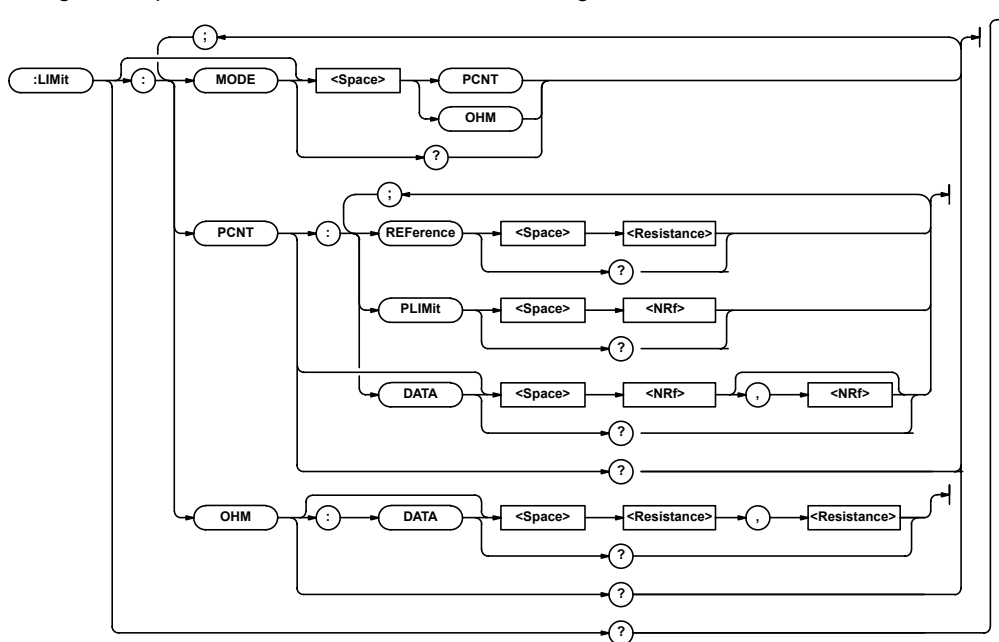

:LIMit?

- Function** Queries all settings related to the limit mode and limit values.
- Syntax** :LIMit?
- Example**
- When the limit mode is set to deviation mode (%)

```
:LIMit?→:LIMIT:MODE PCNT;PCNT:
REFERENCE 1.0000E+05;PLIMIT 9.99;DATA
5.00,-5.00
```
 - When the limit mode is set to absolute mode (R)

```
:LIMit?→:LIMIT:MODE OHM;OHM:DATA
1.0500E+00,0.9500E+00
```

:LIMit[:MODE]

- Function** Sets the limit mode or queries the current setting.
- Syntax** :LIMit[:MODE] {PCNT|OHM}
:LIMit:MODE?
- Response** {PCNT|OHM}
- Example** :LIMIT:MODE PCNT
:LIMIT:MODE?→:LIMIT:MODE PCNT
- Description** When the “:LIMit[:MODE]” setting is changed, the following settings are also automatically changed as follows.
- When changed from OHM to PCNT
Display unit “:DISPlay[:MODE]” Deviation (%)
Limit values “:LIMit:PCNT[:DATA]” HI=0%,
LO=0%
- Ref. val “:LIMit:PCNT:REfERENCE” 100.00 kΩ
- When changed from PCNT to OHM
Display unit “:DISPlay[:MODE]” Absolute(R)
Limit values “:LIMit:OHM[:DATA]” HI= 0 Ω,
LO= 0 Ω

:LIMit:OHM?

- Function** Queries all settings when the limit mode is set to absolute mode (R).
- Syntax** :LIMit:OHM?
- Example** :LIMIT:OHM?→:LIMIT:OHM:DATA 1.0500E+00,
0.9500E+00

:LIMit:OHM[:DATA]

- Function** Sets the limit values (absolute value (R)) or queries the current setting.
- Syntax** :LIMit:OHM[:DATA] {<Resistance (HI)>,<Resistance (LO)>}
:LIMit:OHM:DATA?
- Response** <NR3>,<NR3> (Output in the order HI and LO)
- Example** :LIMIT:OHM:DATA 1.050HM,0.950HM
:LIMIT:OHM:DATA?→:LIMIT:OHM:DATA
1.0500E+00, 0.9500E+00
- Description**
- The HI value must be greater than the LO value. Otherwise, an error (815) occurs.
 - When the “:LIMit[:MODE]” is set to PCNT, the “:LIMit:OHM[:DATA]” setting cannot be changed or queried. Doing so will result in an error (812).

:LIMit:PCNT?

Function	Queries all settings when the limit mode is set to deviation mode (%).
Syntax	:LIMit:PCNT?
Example	:LIMIT:PCNT?→:LIMIT:PCNT: REFERENCE 1.0000E+05;PLIMIT 9.99;DATA 5.00, -5.00

:LIMit:PCNT[:DATA]

Function	Sets the limit values (deviation (%)) or queries the current setting.
Syntax	:LIMit:PCNT[:DATA] {<NRf(HI)>[, <NRf(LO)>]} :LIMit:PCNT:DATA?
	When the “:LIMit:PCNT:PLIMit” is set to 99.9 <NRf> = -9.99 to 9.99% (Resolution 0.01%)
	When the “:LIMit:PCNT:PLIMit” is set to 99.9 <NRf> = -99.9 to 99.9% (Resolution 0.1%)
Response	<NR2>, <NR2> (Outputs in the order HI and LO.)
Example	:LIMIT:PCNT:DATA -5,5 :LIMIT:PCNT:DATA?→:LIMIT:PCNT:DATA 5.00,-5.00
Description	<ul style="list-style-type: none"> The range and resolution of the limit values vary depending on the “:LIMit:PCNT:PLIMit” setting. If the LO parameter is omitted, the value equal to (0 – HI) is set to LO. If HI is less than LO, an error (815) occurs. When the “:LIMit[:MODE]” is set to OHM, the “:LIMit:PCNT[:DATA]” setting cannot be changed or queried. Doing so will result in an error (813).

:LIMit:PCNT:PLIMit

Function	Sets the percent limit when the limit mode is set to deviation (%) or queries the current setting.
Syntax	:LIMit:PCNT:PLIMit {<NRf>} :LIMit:PCNT:PLIMit? <NRf> = 9.99 or 99.9
Response	{9.99 99.90}(<NR2> form)
Example	:LIMIT:PCNT:PLIMit 9.99 :LIMIT:PCNT:PLIMIT?→:LIMIT:PCNT:PLIMIT 9.99
Description	<ul style="list-style-type: none"> When the “:LIMit:PCNT:PLIMit” is changed, the following settings are also automatically changed. <ul style="list-style-type: none"> When the percent limit is changed from 9.99 to 99.9 Limit values HI = 0.0%, LO = 0.0% (:LIMit:PCNT[:DATA]) When the percent limit is changed from 99.9 to 9.99 Limit values HI = 0.00%, LO = 0.00% (:LIMit:PCNT[:DATA]) When the “:LIMit[:MODE]” is set to OHM, the “:LIMit:PCNT:PLIMit” setting cannot be changed or queried. Doing so will result in an error (813).

:LIMit:PCNT:REFEreNce

Function	Sets the reference value when the limit mode is set to deviation (%) or queries the current setting.
Syntax	:LIMit:PCNT:REFEreNce {<Resistance>} :LIMit:PCNT:REFEreNce? <Resistance> = 0.0000 Ω to 120.00 MΩ
Response	<NR3> form
Example	:LIMIT:PCNT:REFERENCE 100KOHM :LIMIT:PCNT:REFERENCE?→:LIMIT:PCNT: REFERENCE 1.0000E+05
Description	<ul style="list-style-type: none"> The measurement range is determined by the “:LIMit:PCNT:REFEreNce” setting. When the “:LIMit[:MODE]” is set to OHM, the “:LIMit:PCNT:REFEreNce” setting cannot be changed or queried. Doing so will result in an error (813).

10.2.8 MEASure Group

The commands in the MEASure Group deal with measurements. These commands can be used to make the same settings and inquiries as when the SETUP/MEAS key on the front panel is pressed.

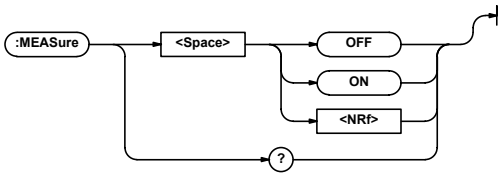

:MEASure

Function Starts or stops the measurement (measurement/SETUP modes) or queries the current setting.

Syntax :MEASure {<Boolean>}
 :MEASure?
 <Boolean> = ON(1)
 Starts the measurement (switches to the measurement mode).
 = OFF(0)
 Stops the measurement (switches to the SETUP mode).

Response {1|0}

Example :MEASURE ON
 :MEASURE? -> :MEASURE 1

Description

- Of the commands provided by the instrument, only the SETUP commands belonging to the groups indicated below can be executed while the measurement is in progress (measurement mode). Attempting to execute the other commands will result in an error (800). Query commands can be executed in either measurement mode or SETUP mode (except for some commands in the RECall Group).
 COMMunicate Group
 DISPlay Group
 MEASure Group
 STATus Group
 Common Command Group
- When the HOLD signal of the handler interface is active (L), only the SETUP commands belonging to the groups indicated below can be executed. (The commands in the Measure Group cannot be executed.) Attempting to execute the other commands will result in an error (801).
 COMMunicate Group
 DISPlay Group
 STATus Group
 Common Command Group

10.2.9 MTIME(Meas TIME) Group

The commands in the MTIME(Meas TIME) Group deal with the measurement time. These commands can be used to make the same settings and inquiries as when the MEAS TIME key on the front panel is pressed.

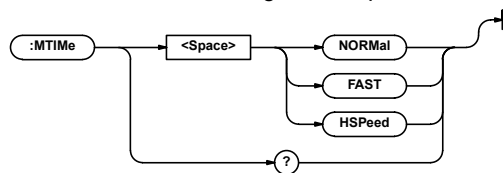

:MTIME

Function	Sets the type of measurement time or queries the current setting.
Syntax	:MTIME {NORMal FAST HSPeed} :MTIME?
Response	{NORMal FAST HSPeed}
Example	:MTIME NORMAL :MTIME?→:MTIME NORMAL
Description	For the measurement time and interval corresponding to the specified type of measurement time (when the trigger mode is set to internal), see page 4-9.

10.2.10 PANel Group

The commands in the PANel Group deal with the initialization of setup information.

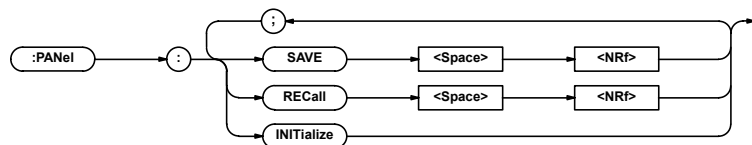

:PANel:INITialize

Function	Initializes settings.
Syntax	:PANel:INITialize
Example	:PANel:INITIALIZE
Description	<ul style="list-style-type: none"> • For the initial values, see page 1-7. • Settings related to communications are not initialized. • When the initialization is executed, all measured data that are stored are cleared.

10.2 Commands

10.2.11 PRINT Group (Option)

The commands in the PRINT Group deal with the print functions available via the Centronics interface.

These commands can be used to make the same settings and inquiries as the “Prin” or “dAtA” menu accessible through the MISC key on the front panel.

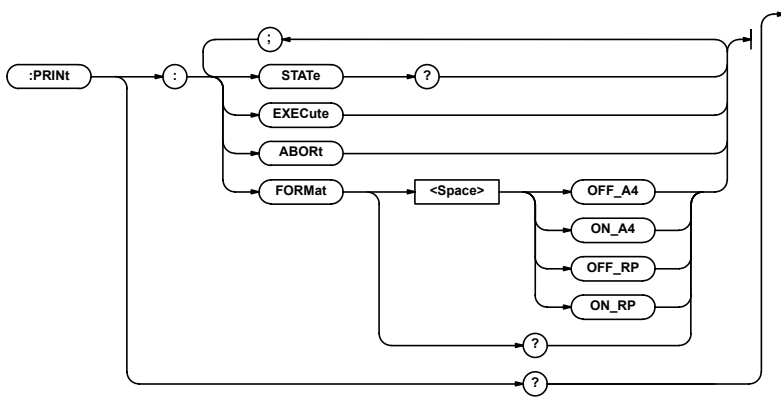

:PRINT?

Function Queries all settings related to the printer output.
 Syntax :PRINT?
 Example :PRINT?→:PRINT:FORMAT OFF_RP

:PRINT:ABORT

Function Aborts printing.
 Syntax :PRINT:ABORT
 Example :PRINT:ABORT

:PRINT:EXECUTE

Function Starts printing. This is an overlap command
 Syntax :PRINT:EXECUTE
 Example :PRINT:EXECUTE
 Description

- Outputs the measured data that are stored in the internal memory and the statistics of the data to an external printer.
- Printing fails with an error (830) if there are no measured data stored in the memory.

:PRINT:FORMAT

Function Sets the contents to be printed (sets whether or not to print measured data) or queries the current setting.
 Syntax :PRINT:FORMAT {OFF_A4|ON_A4|OFF_RP|ON_RP}
 :PRINT:FORMAT?
 OFF_RP = Prints the statistics to a paper size (roll paper) on which 40 characters can be printed horizontally. Measured data are not printed.
 ON_RP = Prints the statistics as well as the measured data to a paper size (roll paper) on which 40 characters can be printed horizontally.
 OFF_A4 = Prints the statistics to an A4 size paper. Measured data are not printed.
 ON_A4 = Prints the statistics as well as the measured data to an A4 size paper.
 Response {OFF_A4|ON_A4|OFF_RP|ON_RP}
 Example :PRINT:FORMAT OFF_A4
 :PRINT:FORMAT?→:PRINT:FORMAT OFF_A4

:PRINT:STATE?

Function Queries the printer output condition.
 Syntax :PRINT:STATE?
 Response {BUSY|IDLE}
 BUSY = Printer busy
 IDLE = Printer ready
 Example :PRINT:STATE?→IDLE

10.2.12 READ Group

The commands in the READ Group deal with the querying of the measured data. There are no front-panel keys that correspond to the commands in this group.



:READ?

Function Queries the measured data.

Syntax :READ?

Response <Measurement information>, <Data>

- <Measurement information> = <NR1> form, register value in decimal notation (See the figure below)
(The values inside the parentheses () are those which exist when the measurement is displayed in Ω.)

0: No data

3 (131): Normal data (Comparator result: IN)

5 (133): Normal data (Comparator result: HI)

9 (137): Normal data (Comparator result: LO)

21: Overrange (Comparator result: fixed to HI)

37: Contact check error (Comparator result: fixed to HI)

69: Abnormalities detected in the test current (Comparator result: fixed to HI)

- <Data> = <NR3> form

When the measurement display is set to %
[-]*.*****E+02 Mantissa: 5.5 digits maximum,
Exponent:02 (fixed)

When the measurement display is set to Ω
[-]*.*****E+** Mantissa: 5.5 digits maximum,
Exponent: depends on the measurement range.

When there are no data (Display “----”)

9.91E+37 (NAN:Not A Number)

When overrange (Display “-oL-”)

When contact check error (Display “-n.C-”)

When abnormalities are detected in the test current (Display “-c.F-”)

9.9E+37 (INFINITY:∞)

Example This is an example in which the measurement information is ON (“:HEADer ON”). When the measurement information is OFF, <Measurement information> and “,” are not output.

- During % display: READ?→3,0.00987E+02 (Comparator result:IN) (0.987%)
- During % display: READ?→9,-0.05012E+02 (Comparator result:LO) (-5.012%)
- During Ω display: READ?→133,1.06135E+07 (Comparator result:HI) (10.6135 MΩ)
- When there are no data: READ?→0,9.91E+37
- When the value is over the range:
READ?→21,9.9E+37
- When a contact check error occurs:
READ?→37,9.9E+37

Description

- When abnormalities are detected in the test current : READ?→69,9.9E+37
- The instrument stores the measured results to the measurement data buffer every time a measurement completes. “:READ?” is a query used to inquire about the contents of the measurement data buffer. The buffer is cleared when a query is made.
- When the “:TRIGger:MODE” is set to EXTERNAL or MANUAL, there are cases in which the measurement data buffer is empty, because the next measurement is not yet complete. The response in this case contains no data (<Measurement information> is “0,” <Data> is “9.91E+37”).
- When the measurement is stopped and the instrument switches to the SETUP mode (“:MEASure OFF”), the measurement data buffer is cleared.
- You can determine whether or not the measured result is stored in the measurement data buffer by checking whether or not bit 0 (DAV) of the status register is set to “1.”
- The <Data> condition and the comparator results are included in the <Measurement information>. The bit assignments of the information are as follows:

7	6	5	4	3	2	1	0
OHM	C.F	N.C	OVR	LO	HI	IN	DAV

- bit0 (DAV): Set to “1” when the measured data are stored in the output buffer.
- bit1 (IN): Set to “1” when the comparator result is “IN.”
- bit2 (HI): Set to “1” when the comparator result is “HI.”
- bit3 (LO): Set to “1” when the comparator result is “LO.”
- bit4 (OVR): Set to “1” when the measured value is over the range. (Display “-oL-”)
- bit5 (N.C): Set to “1” when a contact check error occurs. (Display “-n.C-”)
- bit6 (C.F): Set to “1” when abnormalities are detected in the test current. (Display “-C.F-”)
- bit7 (OHM): Set to “1” when the measured data are correct absolute (R) data.

10.2 Commands

10.2.13 RECall Group

The commands in the RECall Group deal with the recalling of the measured data.

These commands can be used to make the same settings and inquiries as when the RECALL DATA key on the front panel is pressed.

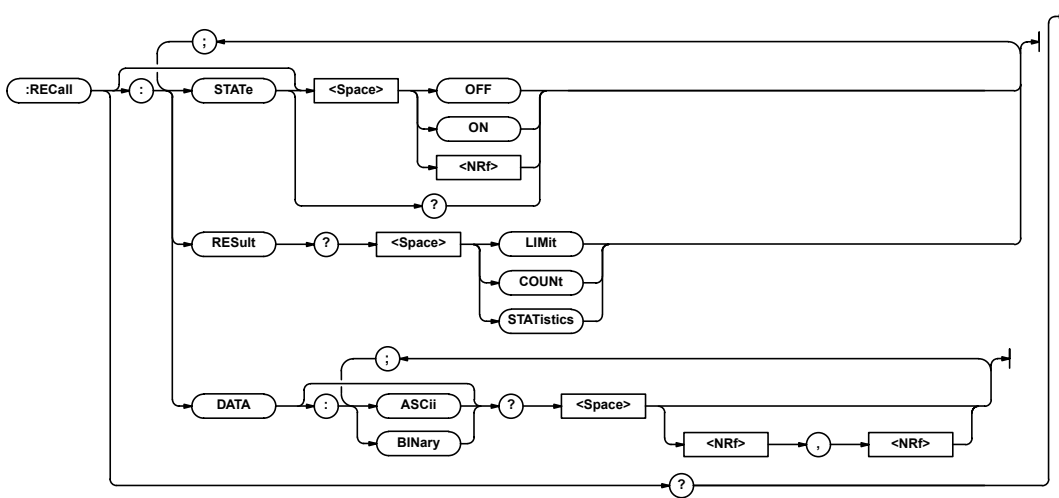

:RECALL?

Function Queries all settings related to the recalling of the measure data.

Syntax :RECALL?

Example :RECALL?→:RECALL:STATE 0

:RECALL:DATA[:ASCIi]?

Function Queries the measured data that are stored in ASCII format.

Syntax :RECALL:DATA[:ASCIi]? {<NRf>, <NRf>}
(Parameters can be omitted)

<NRf>, <NRf> = 1 to 2000 (Specify the
<Recall start number (S)> then the
<Number of recalls (N)>)

Response <Set 1>, <Set 2>, ... ,<Set N>

<Set 1> = “<Measurement information> and
<Measured data>” of the (S)th
data set.

<Set 2> = “<Measurement information> and
<Measured data>” of the (S+1)th
data set.

...

<Set N> = “<Measurement information> and
<Measured data>” of the (S+N-1)th
data set.

- The contents of Set N are all in the “<Measurement information>, <Measured data>” form. This is the same form as the response of the “:READ?” command. If the measurement information is OFF, <Measurement information> and “,” are not output.

Example :RECALL:DATA:ASCIi?→3,0.00987E+02,3,
0.01012E+02,...,3,0.00953E+02

- Description
- If the parameters are omitted, all measured data that are stored are output. In other words, the output is the same as when the parameters are set to {1, (the value equal to :STORE:POINTS?)}.
 - If the number of recalls specified by the parameter is larger than the number of data that are actually stored, “No data” is output for the latter recalls containing no data.
 - This query cannot be made in the measurement mode. Doing so will result in an error (800).

:RECall:DATA:BINary?

Function	Queries the measured data that are stored in binary format.
Syntax	:RECall:DATA:BINary? {<NRf>, <NRf>} (Parameters can be omitted) <NRf>, <NRf>=1 to 2000 (Specify the <Recall start number (S)> then the <Number of recalls (N)>)
Response	#6<Number of bytes><Data> # = Character indicating <Block data> (1 byte) 6 = Number of digits needed to express the <Number of bytes> (1 byte) <Number of bytes> = Six-digit decimal indicating the length of <Measured data> (6 bytes) <Data> = <Set 1><Set 2>...<Set N> <Set 1> = "<Measurement information> <Measured data>" of the (S)th data set. <Set 2> = "<Measurement information> <Measured data>" of the (S+1)th data set. ... <Set N> = "<Measurement information> <Measured data>" of the (S+N-1)th data set. <ul style="list-style-type: none"> The contents of Set N are all in the "<Measurement information> <Measured data>" form. The contents of the <Measurement information> and <Measured data> are the same as the response to the ":READ?" command, but the form is different as indicated below. <Measurement information> = 1-byte register value (Not output when the measurement information is turned OFF) <Measured data> = 4-byte IEEE single-precision floating point decimal data The real number RN that is expressed in the IEEE single-precision floating point decimal format is provided by the following equation. S EEEEEEE EMMMMMM MMMMMMM MMMMMMM $RN = (-1)^S * (2^{(E-127)}) * (1 + M / (2^{23}))$ S: Sign (0 or 1) E: Exponential value (0 to 254) M: Mantissa value (23-bit binary)
Example	:RECALL:DATA:BINARY?→#6010000<Data>
Description	<ul style="list-style-type: none"> The parameter contents and the data set sequence are the same as the ":RECall:DATA[:AScii]?" command. This query cannot be made in the measurement mode. Doing so will result in an error (800).

:RECall:RESult?

Function	Queries the statistics related to the measured data that are stored.
Syntax	:RECall:RESult? {LIMIT COUNT STATistics} (Parameters can be omitted) LIMIT = Outputs the limit values that existed when data were stored. COUNT = Outputs the result that has been classified by the various conditions of the stored data. STATistics = Outputs the statistics of the stored data.
Response	<ul style="list-style-type: none"> In the case ":RECall:RESult? LIMIT" <Limit-Mode>, <REFERENCE>, <HI-Limit>, <LO-Limit> <Limit-Mode> = {PCNT OHM}: Limit mode <REFERENCE> = <NR3> form: Deviation (%) reference, "9.91E+37" when the limit mode is OHM. <High-Limit> = <NR3> form: Limit value (HI) <Low-Limit> = <NR3> form: Limit value (LO) In the case ":RECall:RESult? COUNT" <IN>, <HI>, <LO>, <NC> <IN> = <NR1> form: Number of comparator results that were IN, "0" when the comparator is turned OFF. <HI> = <NR1> form: Number of comparator results that were HI, "0" when the comparator is turned OFF. <LO> = <NR1> form: Number of comparator results that were LO, "0" when the comparator is turned OFF. <NC> = <NR1> form: Number of contact check errors or occurrences in which abnormalities are detected in the test current. In the case ":RECall:RESult? STATistics" or ":RECall:RESult?" <Valid>, <Invalid>, <Maximum>, <Minimum>, <Extent>, <Average>, <1-Sigma>, <3-Sigma> <Valid> = <NR1> form: Number of valid samples <Invalid> = <NR1> form: Number of invalid samples (Number of data points resulting in <NC> or overage) <Maximum> = <NR3> form: Maximum <Minimum> = <NR3> form: Minimum <Extent> = <NR3> form: Range (Maximum – Minimum) <Average> = <NR3> form: Average <1-Sigma> = <NR3> form: Standard deviation σ <3-Sigma> = <NR3> form: 3σ

10.2 Commands

Example	<pre> :RECALL:RESULT? LIMIT →PCNT,1.0000E+05,5.00, -5.00 :RECALL:RESULT? COUNT→1971,14,8,7 :RECALL:RESULT? STATISTICS→1990,10, 0.06378E+02,-0.05249E+02,0.11627E+02, 0.010057E+02,0.0462821E+02,0.1388463E+02 </pre>
Description	<ul style="list-style-type: none"> • If the parameter is omitted, it is equivalent to specifying STATISTICS. • A query cannot be made if there are no measured data that are stored. Doing so will result in an error (830). • This query cannot be made in the measurement mode. Doing so will result in an error (800). • Statistical computation is performed on the communication output data (5.5 digits).

:RECALL[:STATe]

Function	Sets the measured data recall state (ON/OFF) or queries the current setting.
Syntax	:RECALL[:STATe] {<Boolean>} :RECALL:STATe?
Response	{1 0}
Example	<pre> :RECALL:STATe ON :RECALL:STATe?→:RECALL:STATe 1 </pre>
Description	<ul style="list-style-type: none"> • Executing the “:RECALL[:STATe] ON” command sets the instrument in a recall start ready state. The actual recall operation is not executed at this point. Measured data are recalled from the memory every time a trigger occurs after the instrument is switched to the measurement mode using the “:MEASure ON” command. • When the last data point is recalled, the “:RECALL[:STATe]” is automatically turned OFF. Executing the “:RECALL[:STATe] OFF” command will forcibly terminate the recall operation. • When there are no measured data stored in the memory, “:RECALL[:STATe]” cannot be turned ON. This will result in an error (830). • If the “:STORe[:STATe]” is turned ON, “:RECALL[:STATe]” cannot be turned ON. Attempting to do so will result in an error (832).

10.2.14 SELFtest Group

The commands in the SELFtest Group deal with the self test function. These commands can be used to make the same settings and inquiries as the “tEST” menu accessible through the MISC key on the front panel.

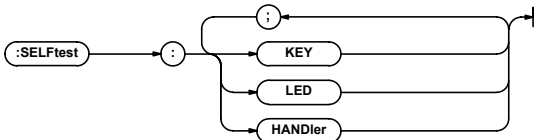

:SELFtest:KEY

Function	Executes the panel key test.
Syntax	:SELFtest:KEY
Example	:SELFTEST:KEY
Description	For the test description, see page 11-6.

:SELFtest:LED

Function	Executes the LED test.
Syntax	:SELFtest:LED
Example	:SELFTEST:LED
Description	For the test description, see page 11-6.

:SELFtest:HANDler

Function	Executes the handler interface output test.
Syntax	:SELFtest:HANDler
Example	:SELFTEST:HANDLER
Description	For the test description, see page 11-6.

10.2.15 STATus Group

The commands in the STATus Group are used to set or query the settings related to the status report. There are no front-panel keys that correspond to the commands in this group. For details related to the status report, see section 10.3.

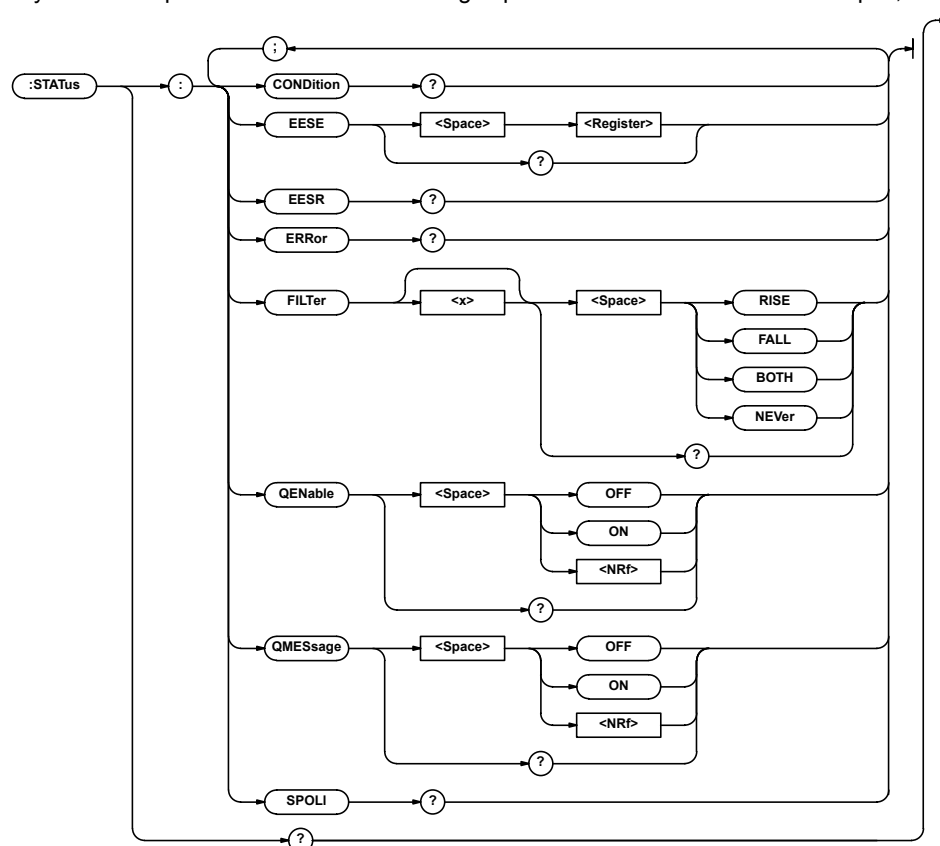

:STATus?

Function Queries all settings related to the communication status.

Syntax :STATus?

Example :STATus?→:STATus:EESR 0;FILTER1 RISE; FILTER2 RISE;FILTER3 RISE; FILTER4 RISE;FILTER5 RISE; FILTER6 RISE;FILTER7 RISE; FILTER8 RISE;FILTER9 RISE; FILTER10 RISE;FILTER11 RISE; FILTER12 RISE;FILTER13 NEVER; FILTER14 RISE;FILTER15 NEVER; FILTER16 NEVER;QENABLE 0;QMESSAGE 1

:STATus:CONDition?

Function Queries the status register.

Syntax :STATus:CONDition?

Response <NR1> (Status register, see page 10-45)

Example :STATus:CONDition?→0

:STATus:EESR?

(Extended Event Status Register)

Function Sets the extended event enable register or queries the current setting.

Syntax :STATus:EESR <Register>
:STATus:EESR?

<Register> = 0 to 65535 (Extended event enable register, see page 10-39)

Response <NR1>

Example :STATus:EESR #B0000000001110000
:STATus:EESR?→:STATus:EESR 112

:STATus:EESR?

(Extended Event Status Register)

Function Queries the extended event register and clears the register.

Syntax :STATus:EESR?

Response <NR1> (Extended event register, see page 10-39)

Example :STATus:EESR?→1

Description For the procedures regarding the use of the extended event register for synchronization, see page 10-8.

10.2 Commands

:STATus:ERRor?

Function Queries the error code and message information (beginning of the error queue).

Syntax :STATus:ERRor?

Response <NR1>, <Character string>

Example :STATUS:ERROR?→113,"Undefined header"

Description

- "0, No error" is returned when there are no errors.
- You can select whether or not to attach the content of the message using the ":STATus:QMESsage" command.

:STATus:FILTer<x>

Function Sets the transition filter or queries the current setting.

Syntax :STATus:FILTer<x> {RISE|FALL|BOTH|NEVer}
:STATus:FILTer<x>?
<x> = 1 to 16

Response {RISE|FALL|BOTH|NEVer}

Example :STATUS:FILTER2 RISE
:STATUS:FILTER2?→:STATUS:FILTER2 RISE

Description Determines how the status register bit is to change for an event to be set. If "Rise" is selected, an event is set when the bit changes from "0" to "1."

:STATus:QENable

Function Sets whether or not to store messages other than errors in the error queue or queries the current setting.

Syntax :STATus:QENable {<Boolean>}
:STATus:QENable?

Response {0|1}

Example :STATUS:QENABLE ON
:STATUS:QENABLE?→:STATUS:QENABLE 1

:STATus:QMESsage

Function Sets whether or not to attach message information to the response to the ":STATus:ERRor?" query or queries the current setting.

Syntax :STATus:QMESsage {<Boolean>}
:STATus:QMESsage?

Response {0|1}

Example :STATUS:QMESSAGE ON
:STATUS:QMESSAGE?→:STATUS:QMESSAGE 1

:STATus:SPOLl? (Serial Poll)

Function Executes serial polling.

Syntax :STATus:SPOLl?

Response <NR1>

Example :STATUS:SPOLL?→0

Description This is a dedicated command of the serial (RS-232) interface.

10.2.16 STORE Group

The commands in the STORE Group deal with the storing of the measured data. These commands can be used to make the same settings and inquiries as when the STORE DATA key on the front panel is pressed.

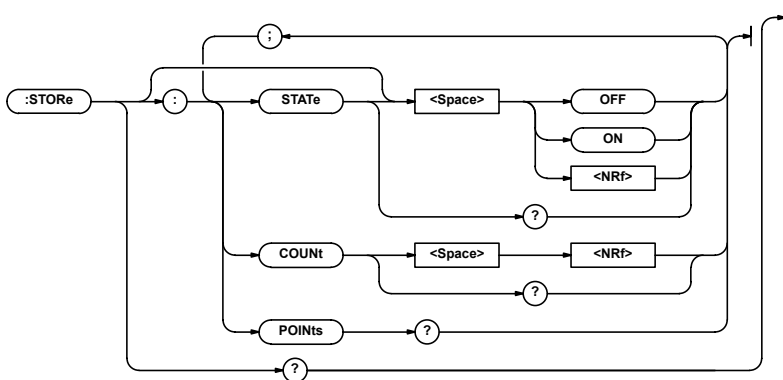

:STORE?

Function Queries all settings related to the storing of the measured data.

Syntax :STORE?

Example :STORE?→:STORE:STATE 0;COUNT 2000

:STORE:COUNT

Function Sets the number of data points to store or queries the current setting.

Syntax :STORE:COUNT {<NRF>}
:STORE:COUNT?
<NRF> = 1 to 2000

Example :STORE:COUNT 2000
:STORE:COUNT?→:STORE:COUNT 2000

:STORe:POINts?

Function	Queries the number of data points that are stored.
Syntax	:STORe:POINts?
Example	:STORe:POINts?→0
Response	<NR1> form
Description	Outputs the number of measured data points that are currently stored in the internal memory.

:STORe[:STATe]

Function	Sets the measured data store state (ON/OFF) or queries the current setting.
Syntax	:STORe[:STATe] {<Boolean>} :STORe:STATe?
Response	{1 0}
Example	:STORe:STATe ON :STORe:STATe?→:STORe:STATe 1
Description	<ul style="list-style-type: none"> • Executing the “:STORe[:STATe] ON” command sets the instrument in a store start ready state. The actual store operation is not executed at this point. Measured data are stored into the memory every time a trigger occurs after the instrument is switched to the measurement mode using the “:MEASure ON” command. • When the number of data points specified by the “:STORe:COUNT” command is stored, the “:STORe[:STATe]” is automatically turned OFF. Executing the “:STORe[:STATe] OFF” command will forcibly terminate the store operation. • If “:STORe[:STATe]” is turned ON when there are measured data already in the memory, all of the stored data are cleared. • If the “:RECall[:STATe]” is turned ON, “:STORe[:STATe]” cannot be turned ON. Attempting to do so will result in an error (831).

10.2.17 TRIGger Group

The commands in the TRIGger Group deal with the trigger mode, trigger delay, edge, and other settings. These commands can be used to make the same settings and inquiries as the “td” or “EdGE” menu accessible through the TRIG MODE or MISC key on the front panel. For details related to the manual trigger, see section 4.6.

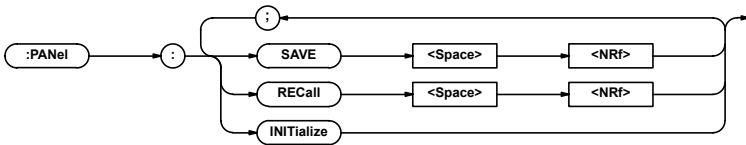

:TRIGger?

Function Queries all settings related to the trigger.
 Syntax :TRIGger?
 Example

- When the trigger mode is set to external trigger
 :TRIGGER?→:TRIGGER:MODE EXTERNAL;
 DELAY 0.0000;EDGE RISE
- When the trigger mode is set to manual trigger
 :TRIGGER?→:TRIGGER:MODE MANUAL;
 DELAY 0.0000
- When the trigger mode is set to internal trigger
 :TRIGGER?→:TRIGGER:MODE INTERNAL

:TRIGger:DELay

Function Sets the trigger delay or queries the current setting.
 Syntax :TRIGger:DELay{<Time>|MAX|MIN}
 :TRIGger:DELay?
 <Time> = 0 to 1s (Resolution 0.1 ms)
 MAX = 1s
 MIN = 0s
 Response <NR2> form
 Example :TRIGGER:DELAY 0S
 :TRIGGER:DELAY?→:TRIGGER:DELAY 0.0000
 Description The trigger delay is valid only when the trigger mode is set to external trigger or manual trigger.

:TRIGger:EDGE

Function Sets the trigger edge or queries the current setting.
 Syntax :TRIGger:EDGE {RISE|FALL}
 :TRIGger:EDGE?
 RISE = Rising edge
 FALL = Falling edge
 Response {RISE|FALL}
 Example :TRIGGER:EDGE RISE
 :TRIGGER:EDGE?→:TRIGGER:EDGE RISE
 Description The trigger edge is valid only when the trigger mode is set to external trigger.

:TRIGger:MODE

Function Sets the trigger mode (external/manual/internal) or queries the current setting.
 Syntax :TRIGger:MODE {INTERNAL|EXTERNAL|MANUAL}
 :TRIGger:MODE?
 EXTERNAL = External trigger mode
 MANUAL = Manual trigger mode
 INTERNAL = Internal trigger mode
 Response {INTERNAL|EXTERNAL|MANUAL}
 Example :TRIGGER:MODE EXTERNAL
 :TRIGGER:MODE?→:TRIGGER:MODE EXTERNAL

10.2.18 Common Command Group

The commands in the common group are defined in the IEEE 488.2-1992 and are independent of the instrument's functions. There are no front-panel keys that correspond to the commands in this group.

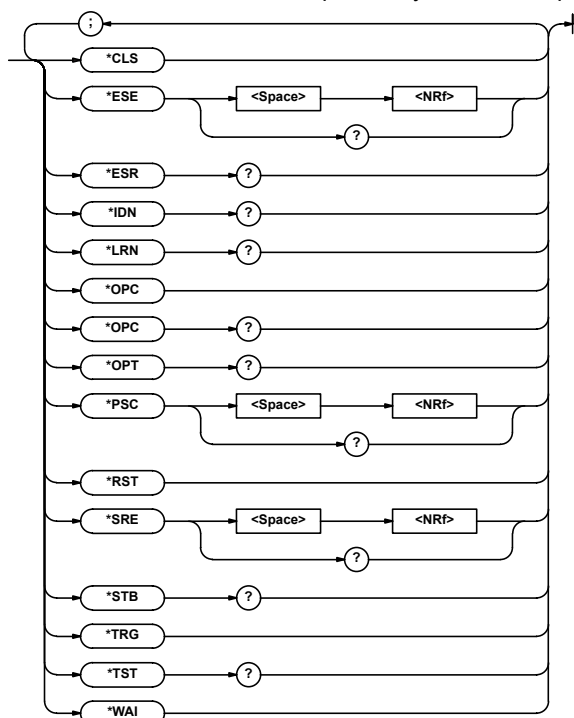

*CLS (Clear Status)

Function Clears the standard event register, extended event register, and error queue.

Syntax *CLS

Example *CLS

Description

- If the “*CLS” command is appended immediately after the program message terminator, the output queue is also cleared.
- For details regarding registers and queues, see section 10.3.

*ESE (standard Event Status Enable register)

Function Sets the standard event enable register or queries the current setting.

Syntax *ESE {<NRf>}

*ESE?

<NRf> = 0 to 255

Example *ESE 251

*ESE?→251

Description

- <NRf> is the sum of the bits expressed as a decimal number.

- In the above example, the standard event enable register is set to “11111011.” In other words, bit 2 of the standard event register is disabled so that even if a query error occurs, bit 5 (ESB) of the status byte register is not set to “1.”
- The default value is “*ESE 0” (all bits disabled).
- An “*ESE?” query will not clear the standard event enable register.
- For details regarding the standard event enable register, see page 10-38.

10.2 Commands

*ESR? (standard Event Status Register)

Function	Queries the standard event register and clears the register.
Syntax	*ESR?
Example	*ESR?→32
Description	<ul style="list-style-type: none">• The sum of the bits is returned as a decimal value.• This query can be used to check the type of event that occurred when a SRQ is in progress.• In the above example, the returned value of “32” indicates that the standard event register is set to “00100000.” In other words, the SRQ occurred due to a “command syntax error.”• An “*ESR?” query will clear the standard event register.• For details regarding the standard event enable register, see page 10-38.

*IDN? (IDeNtify)

Function	Queries the instrument model.
Syntax	*IDN?
Example	*IDN?→YOKOGAWA,755601,0,F1.01
Description	A reply is returned in the following form: <Manufacturer>, <Model>, <Serial number (always 0)>, <Firmware version>.

*LRN? (LeaRN)

Function	Queries current settings of the following groups: LIMit, DISPlay, RANGE, MTIME, TRIGger, CHECK, HANDler
Syntax	*LRN?
Example	*LRN?→:LIMIT:MODE PCNT;PCNT: REFERENCE 1.0000E+05;PLIMIT 9.99; DATA 0.00, 0.00;:DISPLAY:MODE PCNT;: RANGE 1.0E+05;MTIME NORMAL;TRIGGER: MODE EXTERNAL;DELAY 0.0000;EDGE RISE;: CHECK:MODE BEFORE;LEVEL 30;:HANDLER: EOM 0.0100

*OPC (OPeration Complete)

Function	Sets bit 0 of the standard event register (OPC) upon the completion of the specified overlap command.
Syntax	*OPC
Example	*OPC
Description	<ul style="list-style-type: none">• For the procedures regarding the use of the “*OPC” command for synchronization, see page 10-7.• An overlap command is specified using the “:COMMunicate:OPSE” command.• Proper operation is not guaranteed unless the “*OPC” command is placed at the end of the message.

*OPC? (OPeration Complete)

Function	Returns the ASCII code “1” upon the completion of the specified overlap command.
Syntax	*OPC?
Example	*OPC?→1
Description	<ul style="list-style-type: none">• For the procedures regarding the use of the “*OPC?” command for synchronization, see page 10-8.• An overlap command is specified using the “:COMMunicate:OPSE” command.• Proper operation is not guaranteed unless the “*OPC?” command is placed at the end of the message.

*OPT? (OPTion)

Function	Queries the installed options.
Syntax	*OPT?
Example	*OPT?→GP-IB,PRINTER
Description	<ul style="list-style-type: none">• Returns the existence of the <GP-IB interface> and <Centronics interface>.• An ASCII code “0” is returned, if neither of the options is installed.• The “*OPT?” command must be the last query in a program message. Otherwise, an error results.

*PSC (Power-on Status Clear)

Function	Sets whether or not to clear the following registers at power up or queries the current setting. The registers are cleared when a non-zero value is specified. Standard event enable register Extended event enable register Transition filter
Syntax	*PSC {<Nrf>} *PSC? <Nrf> = 0 (Does not clear the register), a non-zero value (Clears the register)
Example	*PSC 1 *PSC?→1
Description	For details regarding registers, see section 10.3.

*RST (ReSeT)

Function	Initializes the settings.
Syntax	*RST
Example	*RST
Description	<ul style="list-style-type: none">• For the initial values, see page 1-7. Setup information except for that related to communications is initialized.• Previously sent *OPC and *OPC? commands are also cleared.

***SRE (Service Request Enable register)**

Function	Sets the service request enable register or queries the current setting.
Syntax	*SRE {<NRf>} *SRE?
Example	<NRf> = 0 to 255 *SRE 239 *SRE?→175 (Because the setting for bit 6 (MSS) is ignored)
Description	<ul style="list-style-type: none"> • <NRf> is the sum of the bits expressed as a decimal number. • In the above example, the service request enable register is set to "11101111." In other words, bit 4 of the service request enable register is disabled so that bit 6 (MSS) of the status byte register is not set to "1" even when the output queue is not empty. • However, bit 6 (MSS) of the status byte register is the MSS bit, and is therefore ignored. • The default value is "*SRE 0" (all bits disabled). • A "*SRE?" query will not clear the service request enable register. • For details regarding the service request enable register, see pages 10-36 and 10-37.

***STB? (STatus Byte)**

Function	Queries the status byte register.
Syntax	*STB?
Example	*STB→4
Description	<ul style="list-style-type: none"> • The sum of the bits is returned as a decimal value. • Because the register is read without serial polling, bit 6 is the MSS bit, not RQS. • In the above example, the returned value of "4" indicates that the status byte register is set to "00000100." In other words, "the error queue is not empty" (an error occurred). • A "*STB?" query will not clear the status byte register. • For details regarding the status byte register see page 10-37.

***TRG (TRiGger)**

Function	Executes a manual trigger and makes one measurement.
Syntax	*TRG
Example	*TRG
Description	<ul style="list-style-type: none"> • This command is valid only when the ":TRIGger:MODE" is set to MANUAL. • The interface message GET (Group Execute Trigger) also achieves the same operation. • For details regarding measurements using the "*TRG" command, see page 10-12.

***TST? (TeST)**

Function	Performs a self test and queries the result.												
Syntax	*TST?												
Example	*TST?→0												
Description	<ul style="list-style-type: none"> • Performs an internal self-test, and returns the sum of the error codes as a test result. If no errors occur, a "0" is returned. This self-test is the same test that is performed at power-up. <table> <thead> <tr> <th>Test Item</th> <th>Error Code</th> </tr> </thead> <tbody> <tr> <td>• Check the minimum voltage level of the backup battery</td> <td>1</td> </tr> <tr> <td>• Check the checksum of the backup RAM (Settings other than those related to communications)</td> <td>2</td> </tr> <tr> <td>• Check the checksum of the backup RAM (Communication settings)</td> <td>4</td> </tr> <tr> <td>• Check the checksum of the backup RAM (SETUP file)</td> <td>8</td> </tr> <tr> <td>• Calibration data(EEPROM)</td> <td>16</td> </tr> </tbody> </table>	Test Item	Error Code	• Check the minimum voltage level of the backup battery	1	• Check the checksum of the backup RAM (Settings other than those related to communications)	2	• Check the checksum of the backup RAM (Communication settings)	4	• Check the checksum of the backup RAM (SETUP file)	8	• Calibration data(EEPROM)	16
Test Item	Error Code												
• Check the minimum voltage level of the backup battery	1												
• Check the checksum of the backup RAM (Settings other than those related to communications)	2												
• Check the checksum of the backup RAM (Communication settings)	4												
• Check the checksum of the backup RAM (SETUP file)	8												
• Calibration data(EEPROM)	16												

***WAI (WAI)t**

Function	Holds the subsequent command until the completion of the specified overlap operation.
Syntax	*WAI
Example	*WAI
Description	<ul style="list-style-type: none"> • For the procedures regarding the use of the "*WAI" command for synchronization, see page 10-7. • An overlap command is specified using the ":COMMunicate:OPSE" command.

10.3 Status Report

10.3.1 About the Status Report

<Status Report>

The figure shows the status report that is read by serial polling. This status report is an extended version of the status report defined in IEEE 488.2-1992.

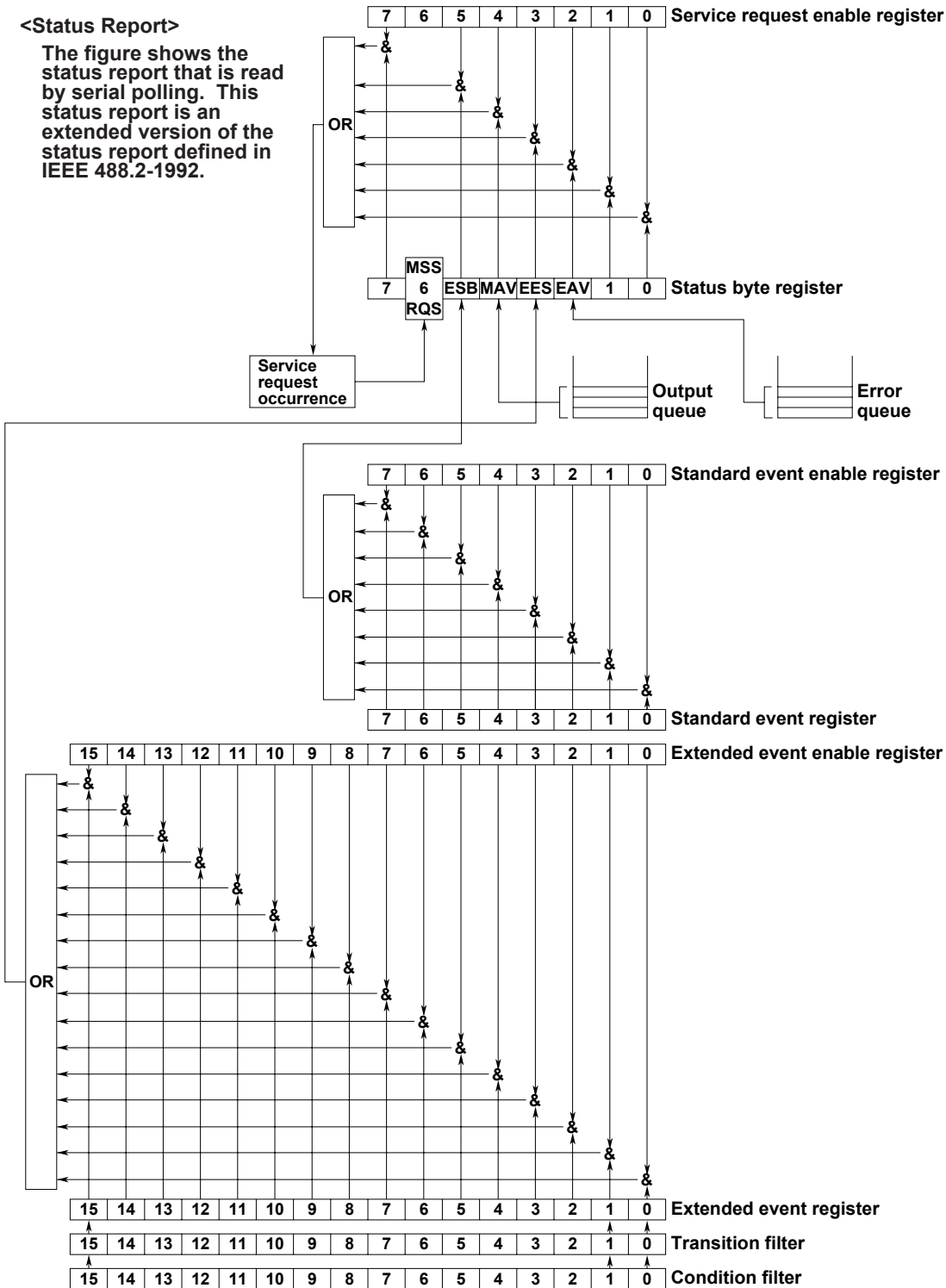

Summary of the Registers and Queues

Name	Function	Write	Read
Status byte		—	Serial polling (RQS), *STB?(MSS)
Service request enable register	Status byte mask	*SRE	*SRE?
Standard event register	Changes in device status	—	*ESR?
Standard event enable register	Standard event register mask	*ESE	*ESE?
Extended event register	Changes in device status	—	STATUS:EESR?
Extended event enable register	Extended event register mask	STATUS:EESE	STATUS:EESE?
Status register	Current device status	—	STATUS:CONDition?
Transition filter	Conditions that change the extended event register	STATUS:FILTer<x>	STATUS:FILTer<x>?
Output queue	Stores a response message to a query	All query commands	
Error queue	Stores the error No. and message	—	STATUS:ERRor?

Registers and Queues that Affect the Status Byte

Registers that affect the contents of the status byte are shown below.

Standard event register:	Sets bit 5 (ESB) of the status byte to "1" or "0."
Output queue:	Sets bit 4 (MAV) of the status byte to "1" or "0."
Extended event register:	Sets bit 3 (EES) of the status byte to "1" or "0."
Error queue:	Sets bit 2 (EAV) of the status byte to "1" or "0."

Enable Registers

Registers that are used to mask a bit so that the bit will not affect the status byte, even if it is set to 1, are shown below.

Status byte:	Mask the bits using the service request enable register.
Standard event register:	Mask the bits using the standard event enable register.
Extended event register:	Mask the bits using the extended event enable register.

Reading and Writing to the Registers

For example, the *ESE command is used to set the bits in the standard event enable register to 1's or 0's. The *ESE? command is used to query whether the bits in the standard event enable register are 1's or 0's. For details regarding these commands, see section 10.2.

10.3.2 Status Byte

Status byte



Bits 0, 1, and 7

Not used (always 0)

Bit 2 EAV (Error Available)

Set to "1" when the error queue is not empty. In other words, this bit is set to "1" when an error occurs. See page 10-40.

Bit 3 EES (Extend Event Summary Bit)

Set to "1" when the logical product of the extended event register and the corresponding event register is not "0." In other words, this bit is set to "1" when an event occurs inside the instrument. See page 10-39.

Bit 4 MAV (Message Available)

Set to "1" when the output queue is not empty. In other words, this bit is set to "1" when there are data to be transmitted. See page 10-40.

Bit 5 ESB (Event Summary Bit)

Set to "1" when the logical product of the standard event register and the corresponding event register is not "0." In other words, this bit is set to "1" when an event occurs inside the instrument. See page 10-39.

Bit 6 RQS (Request Service)/MSS (Master Status Summary)

Set to "1" when the logical AND of the status byte excluding Bit 6 and the service request enable register is not "0." In other words, this bit is set to "1" when the instrument is requesting service from the controller. RQS is set to "1" when the MSS bit changes from "0" to "1," and cleared when the MSS bit changes to "0."

Bit Masking

If you wish to mask a certain bit of the status byte so that it does not cause a SRQ, set the corresponding bit of the service request enable register to "0." For example, to mask bit 2 (EAV) so that service is not requested when an error occurs, set bit 2 of the service request enable register to "0." This is done using the *SRE command. The *SRE? request command can be used to query the service request enable register to check whether each bit is set to "1" or "0." For details regarding the *SRE command, see section 10.2.

10.3 Status Report

Status Byte Operation

A service request is issued when bit 6 of the status byte becomes a "1." Bit 6 is set to "1" when any of the other bits becomes a "1" (when the corresponding bit of the service request enable register is also set to "1"). For example, if an event occurs and the logical AND of the standard event register and the corresponding enable register becomes a "1", then bit 5 (ESB) is set to "1." At this point, if bit 5 of the service request enable register is "1," then bit 6 (MSS) is set to "1" causing the instrument to request service from the controller.

In addition, you can also check what type of event occurred by reading the contents of the status byte.

Reading the Status Byte

The following two methods are available to read the contents of the status byte.

- **Query using the *STB? command**

A *STB? query causes bit 6 to be a MSS bit.

Therefore, the MSS bit is read. No bits in the status byte are cleared after reading the status byte.

- **Serial polling**

Serial polling causes bit 6 to be a RQS bit. Therefore, the RQS bit is read. After reading the status byte, only the RQS bit is cleared. You cannot read the MSS bit when serial polling is used.

Clearing the Status Byte

There are no methods available that can forcibly clear all the bits of the status byte. The bits that are cleared for each operation are shown below.

- **When a query is made using the *STB? command**

None of the bits are cleared.

- **When serial polling is executed**

Only the RQS bit is cleared.

- **When a *CLS command is received**

Receiving the *CLS command will not clear the status byte itself, but the contents of the standard event register that affect the status byte. As a result, the corresponding bit of the status byte is cleared. Since the *CLS command does not clear the output queue, bit 4 (MAV) of the status byte is unaffected. However, if the *CLS command is received immediately after the program message terminator, the output queue is also cleared.

10.3.3 Standard event register

Standard event register

7	6	5	4	3	2	1	0
PON	URQ	CME	EXE	DDE	QYE	RQC	OPC

Bit 7 PON (Power ON)

Set to "1" when the instrument is turned ON.

Bit 6 URQ (User Request)

Not used (always 0)

Bit 5 CME (Command Syntax Error)

Set to "1" when there is an error in the command syntax.

Example: Misspelling of a command name, "9" exists in octal data

Bit 4 EXE (Execution Error)

Set to "1" when the command syntax is correct, but the command cannot be executed in the current state of the instrument.

Example: Parameter outside the range, Tried to print while measurement is in progress.

Bit 3 DDE (Device Dependent Error)

Set to "1" when a command cannot be executed for internal reasons other than a command syntax error and command execution error.

Bit 2 QYE (Query Error)

Set to "1" when a query command is transmitted, but the error queue is empty or the data are lost.

Example: No response data, Output queue overflowed and data were lost.

Bit 1 RQC (Request Control)

Not used (always 0)

Bit 0 OPC (Operation Complete)

Set to "1" when the operation specified by the *OPC command (see section 10.2) has been completed.

Bit Masking

If you wish to mask a certain bit of the standard event register so that it does not cause bit 5 of the status byte to change, set the corresponding bit of the standard event enable register to "0." For example, to mask bit 2 (QYE) so that the ESB bit is not set to "1" when a query error occurs, set bit 2 of the standard event enable register to "0." This is done using the *ESE command. The *ESE? request command can be used to query the standard event enable register to check whether each bit is set to "1" or "0." For details regarding the *ESE command, see section 10.2.

Standard Event Register Operation

Standard event register is a register for the eight types of events that occur inside the instrument. When any of the bits becomes a “1,” bit 5 of the status byte is set to “1” (when the corresponding bit of the standard event enable register is also set to “1”).

Example

1. A query error occurs.
2. Bit 2 (QYE) is set to “1.”
3. If bit 2 of the standard event enable register is a “1,” then bit 5 (ESB) of the status byte is set to “1.”

In addition, you can also check what type of event occurred in the instrument by reading the contents of the standard event register.

Reading the Standard Event Register

The *ESR? command can be used to read the contents of the standard event register. The register is cleared after it is read.

Clearing the Standard Event Register

The standard event register is cleared in the following three cases.

- When the contents of the standard event register are read using the *ESR command.
- When the *CLS command is received.
- When the instrument is powered up again.

10.3.4 Extended Event Register

The transition filter detects the changes of a particular bit of the status register and writes the result to the extended event register.

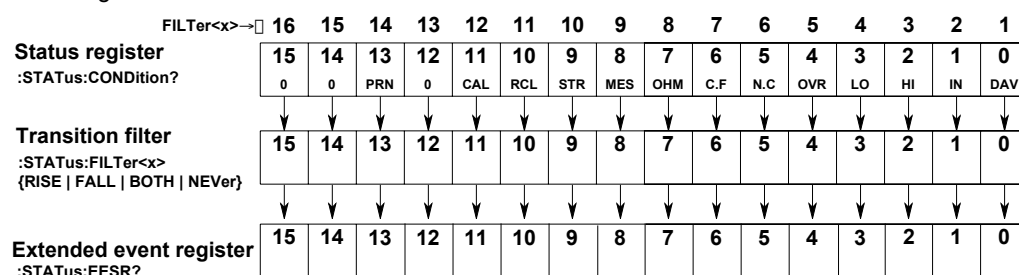

The meaning of each bit of the status register, that indicates the internal condition of the instrument, is as follows:

Bit 0	DAV (Data Available)	Set to “1” when there are data stored in the measurement data buffer.
Bit 1	IN	Set to “1” when the comparator result is “IN.”
Bit 2	HI	Set to “1” when the comparator result is “HI.”
Bit 3	LO	Set to “1” when the comparator result is “LO.”
Bit 4	OVR (OVer)	Set to “1” when an overrange occurs.
Bit 5	N.C (No Contact)	Set to “1” when a contact check error occurs.
Bit 6	C.F (Current Failure)	Set to “1” when abnormalities are detected in the test current.
Bit 7	OHM	Set to “1” when the unit of measurement is Ω .
Bit 8	MES (MESure& lock)	Set to “1” while the measurement is in progress (measurement mode).
Bit 9	STR (SToRe on)	Set to “1” while the measured data are being stored.
Bit 10	RCL (ReCaLI on)	Set to “1” while the measured data are being recalled.
Bit 12	CAL (CALibration mode)	Set to “1” when the instrument is being calibrated.
Bit 13	PRN (PRiNting)	Set to “1” while data are output via the Centronics interface.

The transition filter parameters detect changes in the specified bit (numerical suffix, 1 to 16) of the status register in the following manner and overwrite the extended event register.

RISE	Sets the specified bit of the extended event register to “1”, on a 0-to-1 change.
FALL	Sets the specified bit of the extended event register to “1”, on a 1-to-0 change.
BOTH	Sets the specified bit of the extended event register to “1”, on both 0-to-1 and 1-to-0 change.
NEVer	Always 0.

10.3.5 Output Queue and Error Queue

Output Queue

The output queue stores response messages for the queries. For example, when the controller sends a :READ? command requesting the output of measured data, data are stored in the output queue until they are read.

As shown in the figure below, data are stored in order and read from the oldest ones first. The output queue is also cleared for the following cases.

- when a new message is received from the controller.
- When a deadlock occurs (see page 10-2)
- When a device clear command (DCL or SDC) is received.
- When the power is turned ON again.

The *CLS command cannot be used to clear the output queue. Bit 4 (MAV) of the status byte can be used to check whether or not the output queue is empty.

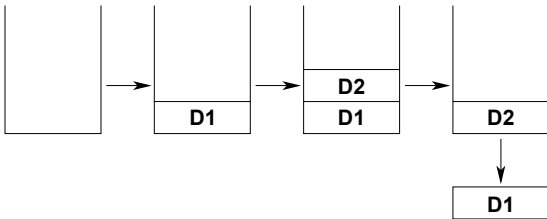

Error Queue

The error queue stores the error number and message when an error occurs. For example, if the controller sends an incorrect program message, the error number "113" and the message "Undefined header" are stored in the error queue when the error is displayed.

The STATUS:ERRor? query can be used to read the contents of the error queue. As with the output queue, the messages are read from the oldest ones first.

When the error queue overflows, the last message is replaced by the message "-350, Queue overflow."

The error queue is also cleared for the following cases.

- When the *CLS command is received.
- When the power is turned ON again.

Bit 2 (EAV) of the status byte can be used to check whether or not the error queue is empty.

10.4 ASCII Character Codes

	0	1	2	3	4	5	6	7
0	0 NUL	20 DEL	40 SP	60 0	100 @	120 P	140 '	160 p
1	1 SOH	21 DC1	41 !	61 1	101 A	121 Q	141 a	161 q
2	2 STX	22 DC2	42 "	62 2	102 B	122 R	142 b	162 r
3	3 ETX	23 DC3	43 #	63 3	103 C	123 S	143 c	163 s
4	4 EOT	24 DC4	44 \$	64 4	104 D	124 T	144 d	164 t
5	5 ENQ	25 NAK	45 %	65 5	105 E	125 U	145 e	165 u
6	6 ACK	26 SYN	46 &	66 6	106 F	126 V	146 f	166 v
7	7 BEL	27 ETB	47 ,	67 7	107 G	127 W	147 g	167 w
8	10 BS	30 CAN	50 (70 8	110 H	130 X	150 h	170 x
9	11 HT	31 EM	51)	71 9	111 I	131 Y	151 i	171 y
A	12 LF	32 SUB	52 *	72 :	112 J	132 Z	152 j	172 z
B	13 VT	33 ESC	53 +	73 ;	113 K	133 [153 k	173 {
C	14 FF	34 FS	54 ,	74 <	114 L	134 \	154 l	174
D	15 CR	35 GS	55 -	75 =	115 M	135]	155 m	175 }
E	16 SO	36 RS	56 .	76 >	116 N	136 ^	156 n	176 ~
F	17 SI	37 US	57 /	77 ?	117 O	137 _	157 o	177 DEL (RUBOUT)
	Address Command	Universal Command	Listener Address		Talker Address		Secondary Command	

Example

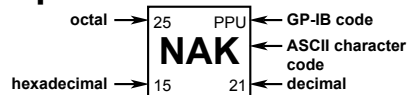

10.5 About the IEEE.488.2-1992 Standard

The GP-IB interface of the instrument conforms to the IEEE 488.2-1992 Standard. This standard specifies that the following 23 points be stated in the document. This section will describe these points.

- 1 Of the IEEE 488.1 interface functions, the subsets that are supported
See section 9.1, "GP-IB Interface Functions and Specifications."
- 2 The operation of the device when it is assigned an address outside the 0 to 30 range.
The address of this instrument cannot be set to an address outside the 0 to 30 range.
- 3 Reaction of the device when the user changes the address
The address is changed when a new address is set using the I/F key menu. The new address is valid until the next time it is changed.
- 4 Device settings at power-up. The commands that can be used at power-up.
Basically, the previous settings are used (settings that existed when the power was turned OFF). All commands can be used at power-up.
- 5 Message exchange options
 - a Input buffer size
1024 byte
 - b Queries that return multiple response messages
See the example of the commands given in section 10.2.
 - c Queries that create response data when the command syntax is being analyzed
All queries create response data when the command syntax is analyzed.
 - d Queries that create response data during reception
There are no queries of which the response data are created upon receiving a send request from the controller.
 - e Commands that have parameters that restrict one another
Some commands, such as the :LIMit:PCNT:PLIMit and [:DATA], have parameters that restrict unilaterally, but there are no commands that have parameters that mutually restrict one another.
- 6 Items that are included in the functional or composite header elements constituting a command.
See sections 10.1 and 10.2.
- 7 Buffer sizes that affect block data transmission
The output queue is expanded to the appropriate size when block data are transmitted.
- 8 A list of program data elements that can be used in equations and their nesting limitations
Equations cannot be used.
- 9 Syntax of the responses to queries
See the example of the commands given in section 10.2.
- 10 Communication between devices that do not follow the response syntax.
See section 9.5, "Switching to the Talk-only Mode."

- 11 Size of the response data block
4 to 10000((1 + 4) × 2000) bytes
- 12 A list of supported common commands
See section 10.2.18, “Common Command Group.”
- 13 Device condition after a successful calibration
The *CAL command is not supported.
- 14 The maximum length of block data that can be used for the *DDT trigger macro definition
Not supported.
- 15 The maximum length of the macro label for defining macros, the maximum length of block data that can be used for the macro definition, and the process when recursion is used in macro definitions
Macro functions are not supported.
- 16 Reply to the IDN? query
See section 10.2.18, “Common Command Group.”
- 17 The size of the storage area for protected user data for *PUD and *PUD? commands
*PUD and *PUD? are not supported.
- 18 The length of the *RDT and *RDT? resource names
*RDT and *RDT? are not supported.
- 19 The change in the status due to *RST, *LRN?, *RCL, and *SAV
*RST, *LRN?
See section 10.2.18, “Common Command Group.”
*RCL, *SAV
These common commands are not supported.
- 20 The extent of the self-test using the *TST? command
The self-test consists of the same tests that are performed at power-up. For details, see section 10.2.18, “Common Command Group.”
- 21 The structure of the extended return status
See section 10.3.
- 22 Whether each command is processed in an overlap fashion or sequentially
See section 10.1.5, “Synchronization with the Controller” and section 10.2.
- 23 The description of the execution of each command
See the functions of each command given in section 10.2.

11.1 Troubleshooting

Troubleshooting

- For corrective actions when a message appears on the screen, read the following pages.
- If servicing is required or if the instrument does not operate properly after taking the following corrective actions, contact your nearest YOKOGAWA dealer.

Problem	Check Item	Reference Page
Nothing is displayed when the power switch is turned ON.	Is the power cord securely connected to the power connector on the instrument? Is the power plug on the other end securely connected to the power outlet?	–
Displayed data are odd.	Is there a possibility that noise is affecting the measurement? Are the ambient temperature and humidity within the allowed range as stated in the specifications?	– 3-2
Cannot make measurements.	Is the instrument in the measurement mode?	4-2
Keys do not operate.	Is the REMOTE indicator turned OFF? Is the instrument in the SETUP mode? Is the HOLD signal of the handler interface inactive?	9-1 4-2, 5-1 5-1, 7-1
The instrument cannot be setup or controlled via the serial interface.	Are the communication specifications between the instrument and the controller properly matched?	8-1
The instrument cannot be setup or controlled via the GP-IB interface.	Does the GP-IP address assigned to the instrument match the address specified in the program? Are the electrical and mechanical specifications of the IEEE St'd 488.1-1987 satisfied?	9-6 9-2
Cannot print	Is the printer in the proper state (on-line) to allow printing?	–

11.2 Messages and Corrective Actions

Error Messages

If an error occurs during operation, an error code (example: *E.800*) may appear on the screen.

This section describes the meanings of the error messages and the corrective actions which they require.

For errors that occur while operating the instrument remotely via the communication interface, the “:STATus:ERRor?” query can be used to check the error code and message.

Example :STATus:ERRor? →800, "Cannot be excuted while running"

Error in communication command (-100 to -199)

Code	Message	Probable Cause/Corrective Action	Page
-102	Syntax error	There is a syntax error other than the codes listed below.	Chapter 10
-103	Invalid separator	Use a comma to separate the data.	10-1
-104	Data type error	Write using the correct data form.	10-5, 10-6
-105	GET not allowed.	–	–
-108	Parameter not allowed	Check the number of data points.	10-5, Section 10.2
-109	Missing parameter	Check the number of data points.	10-5, Section 10.2
-111	Header separator error	Use a space to separate the header and data.	10-1
-112	Program mnemonic too long	The length of a mnemonic (alphanumerical character string) must be less than or equal to 12 characters.	Section 10.2
-113	Undefined header	Check the header.	Section 10.2
-120	Numeric data error	A number is needed for the <NRf> form.	10-5
-123	Exponent too large	The absolute value of the exponent in the <NR3> form must be less than or equal to 32000.	10-5, Section 10.2
-124	Too many digits	The number of digits of the mantissa in the <NRf> form must be less than or equal to 255 excluding the preceding “0.”	10-5, Section 10.2
-128	Numeric data not allowed	Write in a data form other than the <NRf> form.	10-5, Section 10.2
-131	Invalid suffix	Check the unit and multiplier of the <resistance> and <time>.	10-5
-134	Suffix too long	Check the unit and multiplier of the <resistance> and <time>.	10-5
-138	Suffix not allowed	Units and multipliers other than those for <resistance> and <time> cannot be used.	10-5
-141	Invalid character data	Select character data from the selections available in {...}).	Section 10.2
-144	Character data too long	The length of character data is less than or equal to 12 characters.	Section 10.2
-148	Character data not allowed	Write in a data form other than character data form.	Section 10.2
-150	String data error	String data cannot be used.	Section 10.2
-158	String data not allowed	String data cannot be used.	Section 10.2
-161	Invalid block data	Block data cannot be used.	10-6, Section 10.2
-168	Block data not allowed	Block data cannot be used.	10-6, Section 10.2
-171	Invalid expression	Expression data cannot be used.	Section 10.2
-178	Expression data not allowed	Expression data cannot be used.	Section 10.2
-181	Invalid outside macro definition	Macro functions defined in IEEE488.2 are not supported.	–

Errors in communication execution (-200 to -299)

Code	Message	Probable Cause/Corrective Action	Page
-221	Setting conflict	Check the relevant setting values.	Section 10.2
-222	Data out of range	Check the setting range for data.	Section 10.2
-223	Too much data	Check the length of bytes of data.	Section 10.2
-224	Illegal parameter value	Check the setting range for data.	Section 10.2
-241	Hardware missing	Check the existence of options.	–

Errors in communication query (-400 to -499)

Code	Message	Probable Cause/Corrective Action	Page
-410	Query INTERRUPTED	Check the order of transmission and reception.	10-2
-420	Query UNTERMINATED	Check the order of transmission and reception.	10-2
-430	Query DEADLOCKED	The length of a program message including the <PMT> is less than or equal to 1024 bytes.	10-2
-440	Query UNTERMINATED after indefinite response	Do not specify a query after the *IDN? or *OPT? command.	–

Errors in System Operation (800 to 899)

Code	Message	Probable Cause/Corrective Action	Page
800	Cannot be executed while running	Stop the measurement (SETUP mode) before executing.	Chapter 4
801	Cannot be executed when HOLD is active	Turn OFF the HOLD signal before executing.	5-1, 7-1
810	Parameter out of range	Set a value within the range.	–
812	Cannot set this parameter in PCNT limit mode	Limit values cannot be set in Ω when the limit mode is set to %.	4-5
813	Cannot set this parameter in OHM limit mode	Limit values and reference value cannot be set when the limit mode is set to R.	4-7
814	Cannot set PCNT display mode in OHM limit mode	To change the measurement display to %, set the limit mode to % and set the reference value.	4-2, 4-3, 5-2
815	Lower limit value is larger than upper limit	Set the limits so that HI is greater than LO.	4-5, 4-7
830	No measured data has been stored	Store measured data before executing.	6-1
831	Cannot store measured data while recall is active	Turn OFF the recall function before executing.	6-1
832	Cannot recall measured data while store is active	Turn OFF the store function before executing.	6-1
850	Cannot be executed while printing	Terminate printing before executing.	6-3
860	Centronics printer error	Power up the printer again.	–
861	Centronics printer is off line	Set the printer to on-line.	–
862	Centronics printer is out of paper	Put paper in the printer.	–
864	Centronics cannot detect printer	Turn ON the printer. Check the connection.	–
870	Must be executed in adjust mode	Switch to the range adjustment mode before executing.	–
871	ZERO measure failure	Check the connection to the standard resistor.	–
872	FULL measure failure	Check the connection to the standard resistor. Check the input parameter value.	–
873	Cannot execute ZERO measure		–
874	Cannot write to EEPROM		–
875	Cannot change the adjusting range	When the full scale measurement of a range is performed properly, the range automatically increments by 1	11-8

11.2 Messages and Corrective Actions

Error in System Operation (901 to 905)

Code	Message	Probable Cause/Corrective Action	Page
900	ROM checksum error	Servicing is required	–
901	Backup lithium battery low	Servicing is required for battery replacement.	–
902	Setup param. checksum error (other than comm.)	Servicing is required	–
903	Setup param. checksum error (comm.)	Servicing is required	–
905	EEPROM checksum error	Servicing is required	–

If an error code in the range 902 to 905 is displayed at power-up, the error remains on the screen until a key is pressed. For system errors (900 to 905), the ":STATus:ERRor?" query cannot be used to inquire error codes and error messages.

Error in System Operation (Communications, 912)

Code	Message	Probable Cause/Corrective Action	Page
912	Fatal error in Communication-driver	Servicing is required	–

Warning (Communications, 5)

Code	Message	Probable Cause/Corrective Action	Page
5	*OPC/? Exists in message	Place the *OPC or *OPC? command at the end of the program message.	–

Miscellaneous (-350, -390)

Code	Message	Probable Cause/Corrective Action	Page
-350	Queue overflow	This error only occurs for the ":STATus:ERRor?" query. The error code does not appear on the instrument's display.	10-40
-390	Overrun error (RS232 only)	Lower the baud rate. This message sometimes appears if a command is sent during the [measurement time].	–

11.3 Self Test

Keys

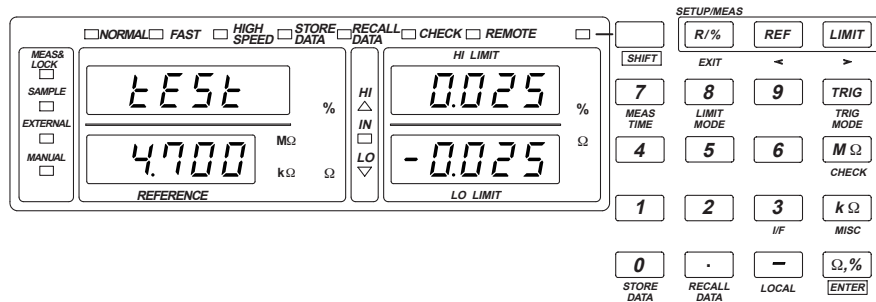

Procedure

The items that are specified or selected are confirmed when the ENTER ($\Omega, \%$) key is pressed. To exit from a menu in the middle of the operation, press the EXIT (R/%) key.

Switching to the SETUP mode

1. Press the $\Omega, \%$ key to switch to the SETUP mode. If the "MEAS & LOCK" indicator is off, this operation is not necessary.

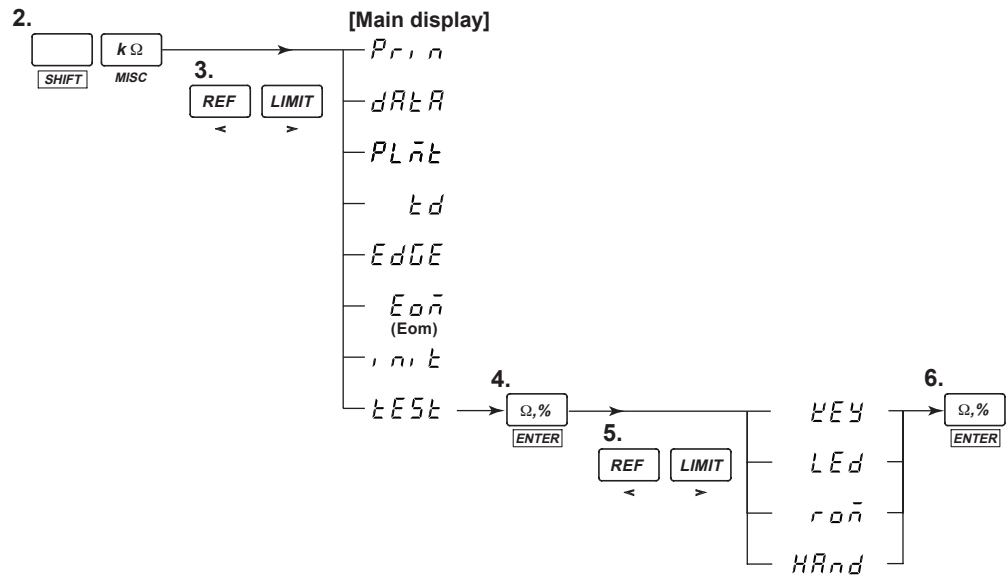

Key test

Select "KEY" at step 5. To cancel a key test that is in progress, press the  key.

LED test

Select "LEd" at step 5.

ROM version check

Select "rom" at step 5. Version information is displayed for approximately 1 s, and the display returns to the top menu of the SETUP mode.

Handler interface test

Select "HAnd" at step 5.

Explanation

The self-test can be performed on the following items. If any part of the test fails, contact your nearest YOKOGAWA dealer.

Key test

Tests whether or not the front panel keys are operating correctly. If the correct number corresponding to the pressed key (00 to 18 correspond to the SHIFT key to the Ω/% key excluding the R/% key) appears on the seven-segment display, the key is operating correctly.

Indicator test

Tests whether or not the seven-segment characters on the screen and other indicators are operating correctly. If all the LEDs turn ON at once, then each one in order, the test is indicates proper operation.

ROM version check

The Software ROM version used by the instrument can be checked.

Handler interface test

Tests whether or not the output signal of the handler interface is normal. The HI, IN, LO, NO CONTACT, EOM, and INDEX signals are activated in order. If the output of all signals is confirmed, the test is successful.

Note

- The key and indicator tests can be aborted in the middle of the test by pressing the EXIT(R/%) key.
 - ROM version and handler interface tests cannot be aborted in the middle of the test. Please wait until the test terminates.
-

11.4 Adjustments

To maintain high measurement accuracy, we recommend that the instrument be adjusted once a year.

Instruments to Prepare

Standard resistor

Nominal Value	Accuracy
1 Ω	± 50 ppm
10 Ω	± 25 ppm
100 Ω to 100 k Ω	± 15 ppm
1 M Ω	± 25 ppm
10 M Ω	± 50 ppm
100 M Ω	± 100 ppm

Recommended instrument: 4808 (Fluke), 2792 (YOKOGAWA)

Environment and Conditions while making the adjustment

Ambient temperature: $23 \pm 1^\circ\text{C}$

Relative humidity: 45 to 75%RH

Supply voltage: 100 V $\pm 5\%$

Frequency: (50/60 Hz) ± 1 Hz

Warm-up: At least 2 hours for the standard resistor and 60 minutes for this instrument before making the adjustment

Precautions while making adjustments

Connect the power cord of the instrument to a three-pole power outlet that has a protective grounding terminal.

Wiring Procedure

**When using Fluke's 4808
Instrument being adjusted**

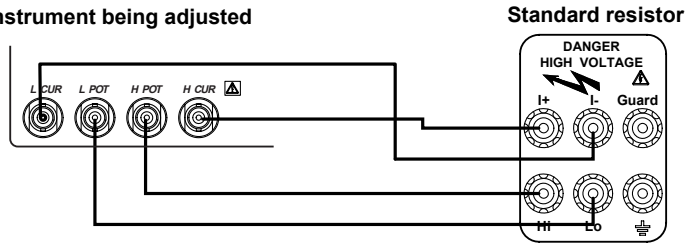

Note

Use shielded wires, and connect the shield to the Guard terminal of the 4808.

**When using 2792 (by YOKOGAWA)
Instrument being adjusted**

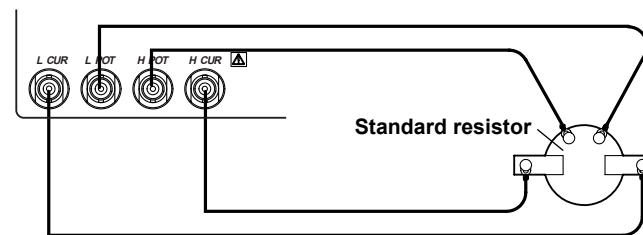

Shorted Input

Instrument being adjusted

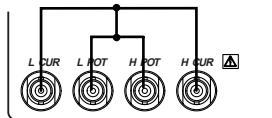

Procedure

1. Prepare and warm up the standard resistor.
2. Turn ON the power while pressing the $\Omega/\%$ key. Continue pressing the $\Omega/\%$ key until "AdJ" appears on the main display.
3. Pressing the ENTER key will cause "0.00000" (755611)^{*1} to blink.
4. Short the input as described in the section "Wiring Procedure, Shorted Input" and press the ENTER key.
The instrument makes a zero measurement for all ranges. If the measurement completes successfully, "1.00000" Ω (755611)^{*2} blinks on the main display. If the zero measurement fails, an error is displayed and the routine returns to step 3.
5. Connect a standard resistor of the nominal value that is displayed on the main display to the instrument.
6. Enter the resistance of the standard resistor using 5.5 digits, and press the ENTER key. On the 755601, entering the 5.5th digit will cause the left most digit to shift to the left and will no longer be displayed.
7. The measured value using the new adjusted value is displayed for approximately three seconds. Then, an [Ok] is displayed (after a full scale measurement of the relevant range) and the next range (10.0000 Ω , for 755611) blinks on the display.
8. Repeat steps 5 to 7 until the adjustment for the 100 M Ω range is complete.
9. After making the adjustment for the 100 M Ω range, "WritE" is displayed. When the ENTER key is pressed, the adjusted values are written to the EEPROM. Then, "AdJ" is displayed on the main display and the adjustment completes. Reboot the instrument.

Completing the adjustment in the middle of the range

5. Press the ENTER key when the adjustment range is blinking on the main display. "WritE" is displayed.
6. When the ENTER key is pressed, the adjusted values existing in the range previous to that which was blinking are written to the EEPROM and the adjustment terminates. Reboot the instrument.

Canceling the range adjustment

5. Press the EXIT(R/%) key when the adjustment range is blinking on the main display. The adjustment is aborted and "AdJ" is displayed. In this case, the adjusted values are not updated.

*1 "0.0000" Ω blinks for the 755601.

*2 "1.0000" Ω blinks for the 755601.

Explanation**Change in the value entry**

While entering values, the <(REF) and >(LIMIT) keys become backspace and clear keys, respectively.

Adjustment range

The adjustment ranges are as follows:

1 Ω , 10 Ω , 100 Ω , 1 k Ω , 10 k Ω , 100 k Ω , 1 M Ω , 10 M Ω , and 100 M Ω

Communication Commands Related to the Adjustment Method

The functions in the CALibrate group are valid only during the range adjustment mode. Read pages 10-1 to 10-4 carefully before executing commands in this group.

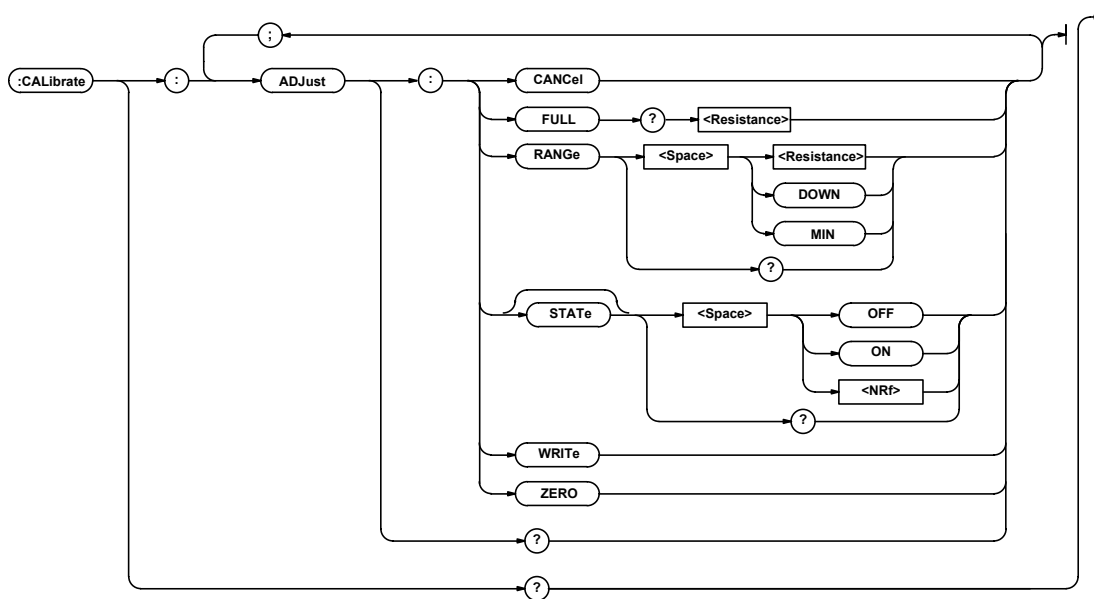

:CALibrate?

Function Queries all settings related to adjustments.
 Syntax :CALibrate?
 Example :CALIBRATE? →:CALIBRATE:ADJUST:STATE 1;
 RANGE 1.0E+05

:CALibrate:ADJust?

Function Queries all setting related to range adjustment.
 Syntax :CALibrate:ADJust?
 Example :CALIBRATE:ADJUST?
 →:CALIBRATE:ADJUST:STATE 1;
 RANGE 1.0E+05
 Description The response is the same as that of the
 “:CALibrate?” query.

:CALibrate:ADJust:CANCeL

Function Terminates the range adjustment without
 writing the adjusted values to the EEPROM.
 Syntax :CALibrate:ADJust:CANCeL
 Example :CALIBRATE:ADJUST:CANCEL
 Description This command is equivalent to the
 “:CALibrate:ADJust[:STATe] OFF” command.

:CALibrate:ADJust:FULL?

Function Executes the full scale measurement for the
 current range and determines the new gain
 adjustment value. At the same time, queries
 the value that is measured using the new
 adjusted value.
 Syntax :CALibrate:ADJust:FULL? {<Resistance>}
 <Resistance> = Resistance of the standard
 resistor
 0.00000 Ω to 120.000 MΩ (The setting
 resolution is 1/10 of the display
 resolution)
 Response <NR3> form
 Example :CALIBRATE:ADJUST:FULL? 100.001KOHM
 →1.00001E+05 (Normal)
 :CALIBRATE:ADJUST:FULL? 100.001KOHM
 →9.9E+37 (When an error occurred)
 Description

- If the result of the full scale measurement of the range is inappropriate, an error 872 occurs, and “9.9E+37” is returned as a response. In addition, the adjustment does not move to the next range.
- If the full scale measurement is completed successfully, the adjustment automatically moves to the next range. Therefore, if you wish to make another full scale measurement at the same range, issue the “:CALibrate:ADJust:RANGe DOWN” command to set the adjustment range back by one before making the measurement again.
- If the zero measurement “:CALibrate:ADJust:ZERO” has not been executed successfully, this command cannot be executed. Otherwise, an error 873 occurs.

:CALibrate:ADJust:RANge

Function	Sets the adjustment range or queries the current setting.
Syntax	:CALibrate:ADJust:RANge {<Resistance> DOWN MIN} :CALibrate:ADJust:RANge? <Resistance>=1, 10, 100, 1K, 10K, 100K, 1M, 10M, 100M (Ω) DOWN=One range below the current range (No change if the current range is 1 Ω) MIN=1 Ω
Response	<NR3> form
Example	:CALIBRATE:ADJUST:RANGE 100KOHM :CALIBRATE:ADJUST:RANGE? →:CALIBRATE:ADJUST:RANGE 1.0E+05
Description	<ul style="list-style-type: none"> The range adjustment starts at 1 Ω, and automatically moves to the next higher range every time the full scale measurement is made. Thus, this command cannot be used to specify a range that is higher than the current range. This command is used to redo a full scale measurement of a range.

:CALibrate:ADJust[:STATe]

Function	Starts or aborts the range adjustment or queries whether or not the range adjustment is in progress.
Syntax	:CALibrate:ADJust[:STATe] {<Boolean>} :CALibrate:ADJust:STATe? <Boolean>=ON(1) Starts the range adjustment. =OFF(0) Terminates the range adjustment without writing the adjusted values to the EEPROM.
Response	{1 0}
Example	:CALIBRATE:ADJUST:STATE ON :CALIBRATE:ADJUST:STATE? →:CALIBRATE:ADJUST:STATE 1
Description	The OFF(0) setting is equivalent to executing the ":CALibrate:ADJust:CANceL" command.

:CALibrate:ADJust:WRITe

Function	Writes the adjusted values to the EEPROM and terminates range adjustment.
Syntax	:CALibrate:ADJust:WRITe
Example	:CALIBRATE:ADJUST:WRITE
Description	This command cannot be executed unless new zero and gain values of at least one range are determined. If not, an error 874 occurs. The ":CALibrate:ADJust:RANge?" query can be used to check whether new adjusted values have been determined. If the response is "1.0E+00"(1 Ω range), then full standard measurement has not been performed on any of the ranges, and new adjusted values have not been determined.

:CALibrate:ADJust:ZERo

Function	Executes the zero measurement on all ranges at once to determine the new zero adjustment value.
Syntax	:CALibrate:ADJust:ZERo
Example	:CALIBRATE:ADJUST:ZERO
Description	If the result of the zero measurement is inappropriate, an error 871 occurs. Perform the zero measurement once at the beginning of the range adjustment sequence. Executing this command in the middle of the range adjustment will automatically set the range to 1 Ω . This command is used to redo the range adjustment from the beginning.

11.5 Replacing the Power Fuse



WARNING

- To prevent the possibility of fire, use only a fuse having the specified rating (voltage, current, and type).
 - Make sure to turn OFF the instrument and unplug the power cord before replacing the fuse.
 - Never short the fuse holder.
-

Specified Rating

The power fuse used on this instrument is specified as follows.

Maximum rated voltage: 250 V

Maximum rated current: 315 mA (100/120 V), 160 mA (220/240 V)

Type: Time lag

Standard: VDE/SEMKO/UL/CSA/SEV certified

Part number: A1345EF (100/120 V), A1342EF (220/240 V)

Replacement Procedures

Follow the procedures below to replace the power fuse.

1. Turn OFF the power switch.
2. Unplug the power cord from the power outlet.
3. Press the fuse holder section to the right of the power connector with a Philips screwdriver, for example, and turn it to the left in order to remove the fuse holder. Place a new fuse in the fuse holder, and place the fuse holder back in its original position.

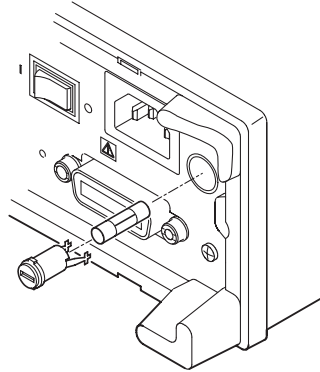

12.1 Input Specifications

Range

When the measurement display is in absolute values (R)

Range	Maximum Display		Resolution		Test Current
	755601	755611	755601	755611	
1 Ω	1.2000	1.20000	100 $\mu\Omega$	10 $\mu\Omega$	100 mA
10 Ω	12.000	12.0000	1 m Ω	100 $\mu\Omega$	100 mA
100 Ω	120.00	120.000	10 m Ω	1 m Ω	10 mA
1 k Ω	1.2000	1.20000	100 m Ω	10 m Ω	1 mA
10 k Ω	12.000	12.0000	1 Ω	100 m Ω	100 μA
100 k Ω	120.00	120.000	10 Ω	1 Ω	50 μA
1 M Ω	1.2000	1.20000	100 Ω	10 Ω	5 μA
10 M Ω	12.000	12.0000	1 k Ω	100 Ω	500 nA
100 M Ω	120.00	120.000	10 k Ω	1 k Ω	50 nA

When the measurement display in deviations (%)

• Percent limit (PLmt) is 9.99

Range of Reference Values Applied	Used Range	Display Range
0.0001 Ω to 1.0009 Ω	1 Ω	
1.001 Ω to 10.009 Ω	10 Ω	
10.01 Ω to 100.09 Ω	100 Ω	-99.999%
0.1001 k Ω to 1.0009 k Ω	1 k Ω	to 19.999%
1.001 k Ω to 10.009 k Ω	10 k Ω	(for 755611)* ¹
10.01 k Ω to 100.09 k Ω	100 k Ω	
0.1001 M Ω to 1.0009 M Ω	1 M Ω	
1.001 M Ω to 10.009 M Ω	10 M Ω	
10.01 M Ω to 120.00 M Ω	100 M Ω	

*¹ -99.99% to 19.99% for 755601.

• Percent limit (PLmt) is 99.9

Range of Reference Values Applied	Used Range	Display Range
0.001 Ω to 1.009 Ω	10 Ω	
1.01 Ω to 10.09 Ω	100 Ω	
10.1 Ω to 100.9 Ω	1 k Ω	-99.99%
0.101 k Ω to 1.009 k Ω	10 k Ω	to 199.99%
1.01 k Ω to 10.09 k Ω	100 k Ω	(for 755611)* ²
10.1 k Ω to 100.9 k Ω	1 M Ω	
0.101 M Ω to 1.009 M Ω	10 M Ω	
1.01 M Ω to 120.0 M Ω	100 M Ω	

*² -99.9% to 199.9% for 755601.

Accuracy (\pm (% of reading + digits))

For 755601 (1 digit = 0.01%, one year after adjustment)

Range	NORMAL	FAST	HIGH SPEED
1 Ω	0.02+2	0.02+3	0.02+5
10 Ω	0.02+1	0.02+2	0.02+4
100 Ω	0.02+1	0.02+2	0.02+4
1 k Ω	0.015+1	0.015+2	0.015+4
10 k Ω	0.015+1	0.015+2	0.015+4
100 k Ω	0.015+1	0.015+2	0.015+4
1 M Ω	0.02+1	0.1+2	0.1+4
10 M Ω	0.04+1	0.3+2	0.3+4
100 M Ω	0.2+2		

* Accuracy at 1 Ω range measuring 0.1 Ω or less (% of reading + Ω) is as follows.

One year after adjustment

NORMAL: 0.02+0.0002

FAST: 0.02+0.0003

HIGH SPEED: 0.02+0.0005

12.1 Input Specifications

For 755611 (1 digit = 0.001%)

- Accuracy 90 days after adjustment

Range	NORMAL	FAST	HIGH SPEED
1 Ω	0.012+10	0.012+20	0.012+30
10 Ω	0.01+3	0.01+10	0.01+20
100 Ω	0.008+3	0.008+10	0.008+20
1 kΩ	0.006+3	0.006+10	0.006+20
10 kΩ	0.006+3	0.006+10	0.006+20
100 kΩ	0.006+3	0.006+10	0.006+20
1 MΩ	0.01+4	0.01+20	0.01+40
10 MΩ	0.03+10	0.3+20	0.3+40
100 MΩ	0.2+20		

- Accuracy one year after adjustment

Range	NORMAL	FAST	HIGH SPEED
1 Ω	0.015+10	0.015+20	0.015+30
10 Ω	0.012+3	0.012+10	0.012+20
100 Ω	0.011+3	0.011+10	0.011+20
1 kΩ	0.009+3	0.009+10	0.009+20
10 kΩ	0.009+3	0.009+10	0.009+20
100 kΩ	0.009+3	0.009+10	0.009+20
1 MΩ	0.015+4	0.015+20	0.015+40
10 MΩ	0.04+10	0.3+20	0.3+40
100 MΩ	0.2+20		

Accuracy at 1 Ω range measuring 0.1 Ω or less (% of reading +Ω) is as follows.

90 days after adjustment

NORMAL: 0.012+0.0001
 FAST: 0.012+0.0002
 HIGH SPEED: 0.012+0.0003

One year after adjustment

NORMAL: 0.015+0.0001
 FAST: 0.015+0.0002
 HIGH SPEED: 0.015+0.0003

Accuracy under the following conditions.

- ±9.99% mode (10 times the digit error of the accuracy shown above for ±99.9% mode)
- 23±5°C
- Add a temperature coefficient at 5 to 18 and 28 to 40°C range.
- Temperature coefficient : ±[1/10 the measurement accuracy (the accuracy one year after adjustment)]/°C
- Only the NORMAL mode is specified for the 100 MΩ range
- Excludes influence from the lead wires

Conditions to satisfy the specifications

- Lead wire resistance of H_{CUR} and L_{CUR} × test current ≤ 1.5 V
- Lead wire resistance of H_{POT} and L_{POT} ≤ 1.5 Ω (1 Ω range)
 ≤ 30 Ω (other than 1 Ω range)

Maximum Common Mode Voltage

Between each measurement input terminal and case: 42 V_{peak}

12.2 Trigger Specifications

Trigger mode: INTERNAL, EXTERNAL, MANUAL

Trigger delay: Setting valid when the trigger mode is set to EXTERNAL or MANUAL
Setting range: 0 to 1000 ms (resolution: 0.1 ms)

Trigger edge: Select rising or falling edge
Setting valid only when the trigger mode is set to EXTERNAL

Trigger ignore time (Time until the next trigger becomes valid)

Types of Measurement Time	Trigger Input Ignore Time
NORMAL	Measurement time + 25 ms
FAST/HIGH SPEED	Measurement time + 10 ms (EOM pulse width of 0.1 ms, 5 ms, and 10 ms) Measurement time + 15 ms (EOM pulse width of 15 ms)

Auto Sampling (Only when the trigger mode is set to INTERNAL)

	Measurement Interval*
NORMAL	50 ms
FAST	20 ms
HIGH SPEED	10 ms

* Add 5 ms when the contact check is ON.

* Add 5 ms when the measurement range is 10 M Ω

* Add 50 ms when the measurement range is 100 M Ω

12.3 Measurement Time Specifications

Mode	Power Frequency	Measurement Time
NORMAL	60 Hz	19.9 ms
	50 Hz	23.2 ms
FAST		5.7 ms
HIGH SPEED		2.8 ms

- Automatically detects the power frequency at power-up.
- Measurement time : From the trigger input to the falling edge of the EOM signal (when the trigger mode is set to EXTERNAL)
- Add 2 ms when the contact check is ON (before measurement).
- Add 1 ms when the contact check is ON (after measurement).
- Add the trigger delay time if it is set.
- Add 4 ms when the measurement range is 10 M Ω .
- Add 50 ms when the measurement range is 100 M Ω

12.4 Contact Check Specifications

Item	Specifications
Check level setting range	1 to 30 Ω (resolution: 1 Ω)
Check time	2 ms
Execution timing	Select before or after the measurement
Test current	50 mA
When a contact check occurs	Display : “-nC-” Determination : HI Handler interface : NO CONTACT, HI output

12.5 Comparator Specifications

Setting Range

Parameter	Absolute Setting Range	Deviation Setting Range	
		Percent Limit: 9.99	Percent Limit 99.9
HI	0.0000 Ω to 1.2000 Ω (for 755611) ^{*1}	-9.999% to 9.999% ^{*3}	-99.99% to 99.99% ^{*4}
LO	0.0000 Ω to 1.2000 Ω (for 755611) ^{*2}	-9.999% to 9.999% ^{*3}	-99.99% to 99.99% ^{*4}

Set so that LO is less than or equal to HI

*1, *2 0.000 Ω to 1.200 Ω for 755601

*3 -9.99% to 9.99% for 755601

*4 -99.9% to 99.9% for 755601

Comparison

The signal output behavior of INDEX, EOM, NO CONTACT, HI, IN and LO signals vary depending on the trigger mode as follows.

When the trigger mode is set to EXTERNAL

INDEX:	Output when a trigger occurs regardless of the measurement result.
EOM:	Output once when the measurement completes regardless of the measurement result.
NO CONTACT:	Output when the measurement result is a contact check error (nC) or when abnormalities are detected in the test current (CF).
HI:	Output when the comparator result of the measured value is HI. Output also when the measurement result is an overrange (oL), contact check error (nC), or when abnormalities are detected in the test current.
IN:	Output when the comparator result of the measured value is IN.
LO:	Output when the comparator result of the measured value is LO.

When the trigger mode is set to MANUAL or INTERNAL

INDEX:	Not output (Stays at H).
EOM:	Not output (Stays at H).
NO CONTACT:	Output when the measurement result is a contact check error (nC) or when abnormalities are detected in the test current (CF). Output when the comparator result of the measured value is HI. Output also when the measurement result is an overrange (oL), contact check error (nC), or when abnormalities are detected in the test current.
IN:	Output when the comparator result of the measured value is IN.
LO:	Output when the comparator result of the measured value is LO.

12.6 Other Specifications

Item	Specifications
Memory function	Store up to 2000 data points of measured data.
Function used to detect abnormalities in the test current	Detects abnormalities in the test current during measurement. Display: “-CF-” Determination: HI Handler output: NO CONTACT, HI output

12.7 Handler Interface Specifications

Connector For details contact your nearest YOKOGAWA dealer

Signal Name

Pin No.	Signal Name	Active Condition	Input/Output	Function/Operation
1	HI	L	Output	L when the comparator result is HI.
2	IN	L	Output	L when the comparator result is IN.
3	LO	L	Output	L when the comparator result is LO.
4	NO CONTACT	L	Output	L when a contact check error occurs or when abnormalities are detected in the test current.
7	+12V	—	Output	Power supply
8	EXT TRIG	Specified edge	Input	External trigger signal
9	EOM	L	Output	L after the measurement is completed and after the output of the comparator result L ^{*1}
10	HOLD	L	Input	Key lock ^{*2}
11	INDEX	L	Output	H when trigger is input, L when data collection is completed L ^{*3}
14	COM	—	—	Common

*1 Select the pulse width from 0.1, 5, 10, 15 ms. The default setting is 10 ms.

*2 When active (L), the instrument switches to the measurement mode (trigger mode is set to EXTERNAL) regardless of the current mode (measurement/SETUP) and makes measurements. All keys except the R/% and STORE DATA keys are disabled (key lock). When the signal changes from L to H the key is enabled. Thus, the SETUP/MEAS key can be pressed to switch to the SETUP mode and make setting changes to the instrument.

*3 When contact check is ON (after measurement), the signal is set to L when the contact check is completed.

Input terminal (EXT TRIG, HOLD)

Input voltage:	LO level \leq 1 V HI level = 12 V or open
Input current (at LO level):	7 mA
Maximum input voltage:	12 V
Minimum pulse width:	100 μ s

Output terminal (HI, IN, LO, NO CONTACT, EOM, INDEX)

Output format:	Open collector
Isolation:	Photo coupler isolation
Rated output voltage:	LO level \leq 0.8 V
Maximum load current:	25 mA
Maximum load voltage:	30 V

Power supply (+12 V)

Maximum load current:	50 mA
-----------------------	-------

Maximum common mode voltage

Between each terminal (pin) and case: 42 V_{peak}

12.8 Communication Specifications

Serial (RS-232) Interface

Item	Specifications
Connector	For details, contact your nearest YOKOGAWA dealer.
Electrical specifications	Conforms to the EIA-574 standard (for the 9-pin interface of the EIA-232 (RS-232) standard)
Connection	Point-to-point
Communication	Full-duplex
Synchronization	Start-stop synchronization
Baud rate	Select from 1200, 2400, 4800, 9600, and 19200 bit/s
Start bit	1 bit (fixed)
Data length	7 or 8 bits
Parity	Even, odd, none
Stop bit	1 or 2 bits
Hardware handshaking	Select whether to fix the CA and CB signals to TRUE or use the signal for flow control
Software handshaking	select whether to use the X-ON and X-OFF signals to control the transmission data. X-ON (ASCII 11H) X-OFF (ASCII 13H)
Received buffer	256 bytes

GP-IB Interface (Option)

Item	Specifications
Electrical and mechanical spec.	Conforms to IEEE St'd 488.1-1987 (JIS C 1901-1992)
Interface Functions	SH1, AH1, T5, L4, SR1, RL1, PP0, DC1, DT1, C0, E1
Protocol	Conforms to IEEE St'd 488.2-1992
Code	ISO (ASCII) code
Mode	Addressable mode/Talk-only mode
Address	Select talker/listener addresses in the range 0 to 30
Remote mode clear	Remote mode can be cleared by pressing the LOCAL key except when the instrument has been set to Local Lockout mode by the controller.
Header	Select ON/OFF

Centronics Interface (Option)

Item	Specifications
Connector	For details, contact your nearest YOKOGAWA dealer.
Electrical specifications	Conforms to Centronics

12.9 General Specifications

Item	Specifications
Operating temperature range	5 to 40°C
Operating humidity range	20 to 80% R.H.
Storage temperature range	-25 to 60°C
Operating altitude	2000 m or less
Rated supply voltage	The supply voltage specified by the suffix code (100/120/220/240 V) \pm 10%, 50/60 Hz
Power consumption	25 VA maximum
Weight	Approx. 4 kg
Warm-up time	At least 30 minutes
External dimensions	Approx. 213 (W) \times 88 (H) \times 350 (D) mm (projections excluded)
Safety standard	Complying standard EN61010-1 Overvoltage Category (Installation Category)II ¹ Pollution degree 2 ² EN61010-2-030 Measurement category Other(O) ⁷

Item	Specifications
Emissions	<p>Complying standard EN61326-1 Class A EN55011 Class A, Group1 EMC Regulatory Arrangement in Australia and New Zealand EN 55011 Class A, Group 1 EN6100-3-2 EN6100-3-3 Korea Electromagnetic Conformity Standard (한국 전자파적합성기준) This is a Class A product. In a domestic environment this product may cause radio interference in which case the user may be required to take adequate measures.</p> <p>Cable condition</p> <ul style="list-style-type: none"> • Measurement input terminal Use a shielded cable for connection. Use a cable of length 1 m or less. For measurements in the 10-MΩ and 100-MΩ ranges, shield the resistor under measurement to the guard potential.*3 • TRIGGER IN terminal For connection, use a BNC cable that is better than or equivalent to the 1.5D-QEW BNC cable. *4 • HANDLER connector Use a shielded cable for connection. *5 • SERIAL (RS-232) connector Use an RS-232 shielded cable for connection.*5 • PRINTER connector Use a shielded cable for connection. *5
Immunity	<p>Complying standard EN61326-1 Table 2 *6</p> <ul style="list-style-type: none"> • Immunity influence Within the measured value $\pm 20\%$ of range • Test condition 100-MΩ range, resistance under measurement: 100 MΩ, measurement time: HIGH SPEED, trigger mode: EXTERNAL, contact check: bEF (before measurement) (The test was performed under the same cable condition as specified for emission.)

*1 Overvoltage Categories define transient overvoltage levels, including impulse withstand voltage levels.

Overvoltage Category I : Applies to equipment supplied with electricity from a circuit containing an overvoltage control device.

Overvoltage Category II: Applies to equipment supplied with electricity from fixed installations like a distribution board.

*2 Pollution Degree : Applies to the degree of adhesion of a solid, liquid, or gas which deteriorates withstand voltage or surface resistivity.

Pollution Degree 1: Applies to closed atmospheres (with no, or only dry, non-conductive pollution).

Pollution Degree 2: Applies to normal indoor atmospheres (with only non-conductive pollution).

*3 "Guard potential" refers to the electrical potential of the conductor on the outside of the BNC connector of the measurement input terminal.

*4 Use a cable of length 2 m or less.

*5 Use a cable of length 3 m or less.

*6 Immunity test requirements for equipment intended for use in industrial locations.

*7 The measurement category of this instrument signal input terminals is Other (O). Do not use it to measure the main power supply or for Measurement Categories II, III, and IV.

Measurement category Other (O) applies to measurement of circuits that are not directly connected to a main power supply. This category applies to measurement of secondary electric circuits in equipment across a transformer. The estimated transient overvoltage that may be applied to the this instrument signal input terminals is 1500 V.

Measurement category II applies to measurement of circuits, such as household electric appliances and portable electric tools, that are connected to low-voltage installations.

Measurement category III applies to measurement of facility circuits, such as distribution boards and circuit breakers.

Measurement category IV applies to measurement of power source circuits, such as entrance cables to buildings and cable systems, for low-voltage installations.

12.10 External Dimensions

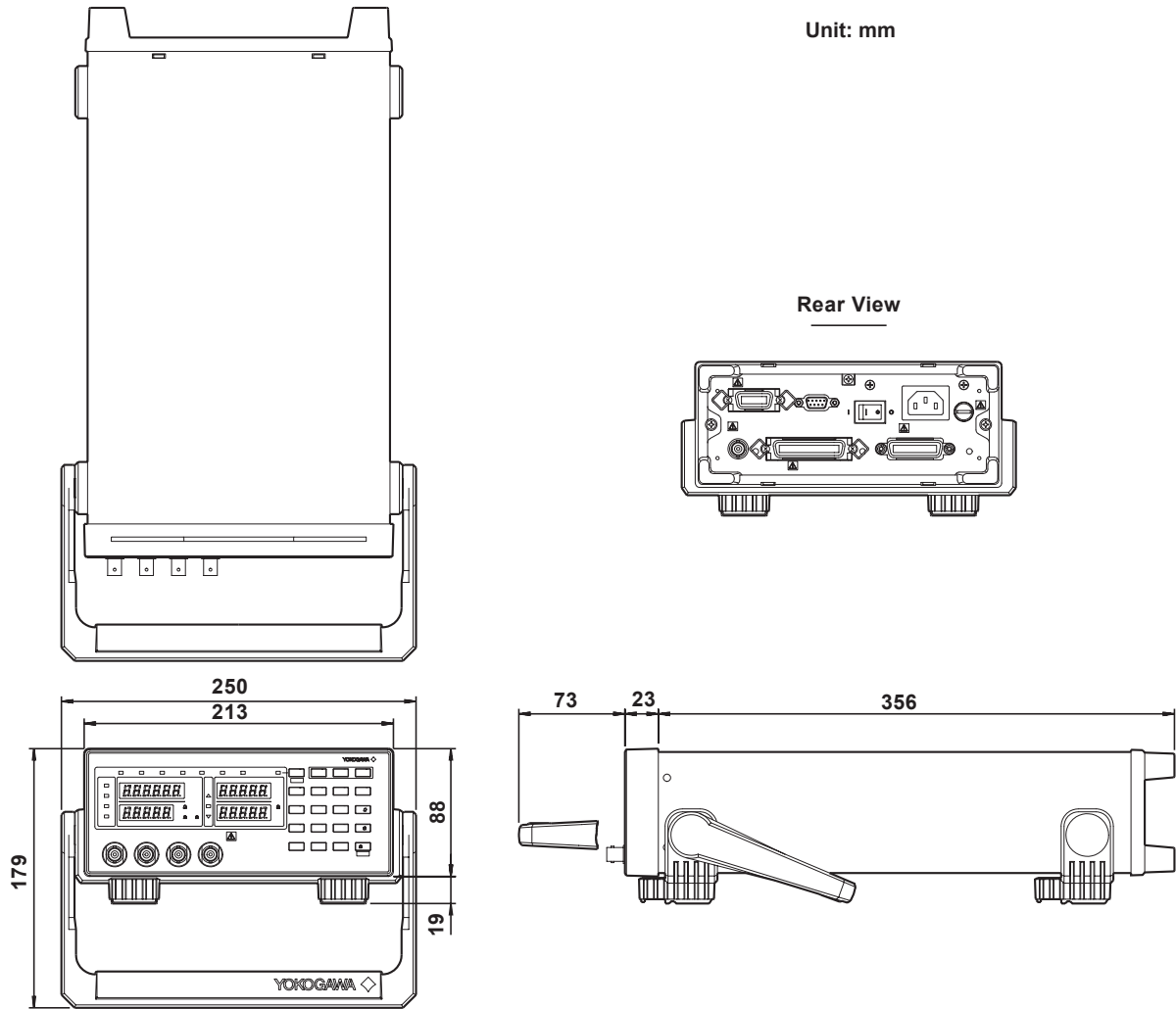

Unless specified otherwise, the tolerance is $\pm 3\%$. However, in cases of less than 10 mm, the tolerance is ± 0.3 mm.

Index

A

abbreviated form 10-4
absolute (R) mode 4-1
address 9-7
addressable mode 9-7
adjustment 11-7, 11-10

B

bar display 2-4
baud rate 8-1, 8-8
block data 10-6
block diagram 1-1
boolean 10-6

C

character data 10-6
check level 4-7
check time 12-4
comparator function 1-2, 4-5
contact check 10-15
contact check function 1-2, 4-7

D

data 10-5
data format 8-8
DCL 9-4
deadlock 10-2
deviation (%) mode 4-1
digital numbers and characters 1-4

E

edge 10-32
EOM 7-1, 7-5
error code 10-30, 11-2
error display 2-4, 5-1
error message 11-2
error queue 10-40
extended event enable register 10-29
extended event register 10-29, 10-39
EXTERNAL 4-11
external trigger input terminal 4-10

F

factory default settings 1-7, 6-7
FAST 4-8
fuse 11-12

G

GET 9-4
GTL 9-4

H

handler interface 1-3, 7-1, 10-18
handshaking method 8-4, 8-8
header 9-7
HI LIMIT 4-5
HI LIMIT display 2-1
HIGH SPEED 4-8

I

IFC 9-4
initial settings 1-7
initial values, a list of 1-7
initialize 6-7, 10-23, 10-34
interface message 9-4
INTERNAL 4-11

K

key test 11-6

L

limit mode 4-1, 10-20
limit value 4-5, 4-6, 10-20
listener 9-1
LLO 9-4
LO LIMIT 4-5
LO LIMIT display 2-1
local 8-1
LOCAL key 8-1
local lockout 10-16

Index

M

main display 2-1
MANUAL 4-11
maximum common mode voltage 12-2
maximum input voltage 12-5
maximum load current 12-5
maximum load voltage 12-5
measured data 10-25
measurement interval 4-11, 12-3
measurement mode 1-3, 5-1, 5-3, 10-22
measurement time 4-8, 4-11, 10-23, 12-3
menus, a list of 1-4
message 10-1
MODEL ii
multi-line message 9-4

N

NORMAL 4-8

O

output queue 10-40
overlap command 10-7
overlap enable register 10-17

P

percent limit 4-5
power cord iii, 3-3
power fuse 11-12
printer output 10-24
printing 6-4
program message 10-1
pulse width of the EOM signal 7-4

R

R/% key 5-3
range 4-3, 12-1
range adjustment 11-9, 11-10
recall 6-2, 10-26
reference display 2-1
reference value 4-2
register 10-6
remote 8-1
REMOTE indicator 8-1
REN 9-4
response data 10-2
response header 10-2
response message 10-2
ROM version 11-6

S

SDC 9-4
self test 10-28, 10-35, 11-5
sequential command 10-7
serial polling 9-4
SETUP mode 1-3, 4-1, 10-22
SPE 9-4
standard event enable register 10-33
standard event register 10-34
statistics 6-5, 10-27
status byte 10-37
status register 10-29, 10-39
status report 10-36
store 6-2, 10-30

T

talk-only 9-1
talk-only mode 9-8
talker 9-1
terminator 8-8
test current 12-4
timing chart 7-5
top menu 1-4
transition filter 10-30, 10-39
trigger 10-35
trigger delay 4-11, 10-32
trigger edge 4-11
trigger mode 1-2, 4-11, 10-32

U

uni-line message 9-4
upper-level query 10-4

W

wiring method 3-5