

# YPP6801 EXPLOSION-PROOF FEET & INCHES LEVEL METER



- 4-20 mA Input Loop-Powered
- 0.6" (15.2 mm) Feet and Inches Display
- Display up to 399 FT, 11 <sup>15</sup>/<sub>16</sub> IN
- Programmable for <sup>1</sup>/<sub>8</sub> or <sup>1</sup>/<sub>16</sub> Inch
- 20-Segment Tank Level Indicator
- 7 Alphanumeric Character, 0.4" (10.2 mm) Lower Display
- Lower Display for Tag, Volume, or Percent
- Through-Glass Button Programming
- 32-Point Linearization
- Open Collector Alarm Output
- Loop-Powered or External DC-Powered Backlight Standard
- HART® Protocol Transparent
- 3.0 V Drop (6.0 V with Backlight)
- Explosion-Proof, IP68, NEMA 4X Enclosure
- Operates from -40 to 75°C

**YOKOGAWA** ◆

2 Dart Road • Newnan, Georgia 30265  
770-253-7000 • 800-888-6400  
Fax: 770-251-2088 • [www.yokogawa-usa.com](http://www.yokogawa-usa.com)

## Disclaimer

The information contained in this document is subject to change without notice. Yokogawa makes no representations or warranties with respect to the contents hereof; and specifically disclaims any implied warranties of merchantability or fitness for a particular purpose.

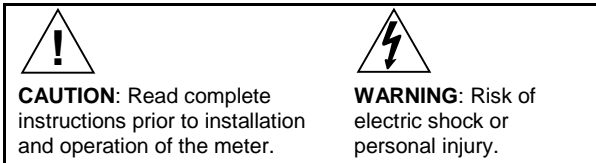

## Warning

- This product is not recommended for life support applications or applications where malfunctioning could result in personal injury or property loss. Anyone using this product for such applications does so at his/her own risk. Yokogawa Corporation of America shall not be held liable for damages resulting from such improper use.
- Failure to follow installation guidelines could result in death or serious injury. Make sure only qualified personnel perform the installation.
- Never remove the meter cover in explosive environments when the circuit is live.
- Cover must be fully engaged to meet flameproof/explosion-proof requirements.

## Limited Warranty

Yokogawa Corporation of America warrants this product against defects in material or workmanship for the specified period under "Specifications" from the date of shipment from the factory. Yokogawa's liability under this limited warranty shall not exceed the purchase value, repair, or replacement of the defective unit.

## Registered Trademarks

All trademarks mentioned in this document are the property of their respective owners.

© 2013 Yokogawa Corporation of America. All rights reserved.

[www.yokogawa-usa.com](http://www.yokogawa-usa.com)

## INTRODUCTION

The YPP6801 is a rugged, explosion-proof loop-powered indicator specifically designed for level applications in hazardous areas or in the harshest environmental conditions. The meter displays level in easy to read and understand feet, inches, and fractions of an inch; and a 20-segment tank level indicator. The lower display can show a custom unit or tag, percent full, or a second scale for the 4-20 mA input used to indicate volume.

The meter derives all of its power from the 4-20 mA loop. It is programmed using the four Through-Glass buttons, without removing the cover, and can be scaled with or without a calibration signal.

The upper display will read up to 399 ft – 11 15/16 inches. The alphanumeric volume/tag display will read up to 9,999,999. The alphanumeric display can also be programmed to show any combination of numbers and letters up to seven characters long for use as engineering units and/or the process identification tag. The backlight lets you see the display under any lighting condition and can be powered from either the 4-20 mA loop or from a separate DC power supply.

The enclosure is provided with two threaded conduit holes and integrated pipe or wall mounting slotted flanges.

## ORDERING INFORMATION

Model	Description
YPP6801-0K1	Explosion-Proof Loop-Powered Feet & Inches Level Meter

## Table of Contents

<b>INTRODUCTION</b> -----	<b>3</b>
<b>ORDERING INFORMATION</b> -----	<b>3</b>
<b>SPECIFICATIONS</b> -----	<b>6</b>
General -----	6
Input -----	7
Open Collector Output -----	7
Product Ratings and Approvals -----	8
Electromagnetic Compatibility -----	9
<b>SAFETY INFORMATION</b> -----	<b>9</b>
<b>INSTALLATION</b> -----	<b>10</b>
Unpacking -----	10
Pre-Installed Conduit/Stopping Plug -----	10
Mounting -----	11
Cover Jam Screw -----	11
Connections -----	11
Input Signal & Backlight Connections .....	13
External Acknowledge Connection .....	14
Open Collector Output Connections .....	15
<b>SETUP AND PROGRAMMING</b> -----	<b>16</b>
<b>Through-Glass Buttons</b> -----	<b>17</b>
Through-Glass Button Operation.....	17
Through-Glass Button Tips and Troubleshooting.....	17
<b>Buttons and Display</b> -----	<b>18</b>
<b>Main Menu</b> -----	<b>20</b>
Setting Numeric Values.....	21
<b>Setting Up the Meter (SETUP)</b> -----	<b>22</b>
Setup Menu Display Functions & Messages.....	23
Scaling the Meter (SCALE) .....	24
Selecting Inch Fraction Display Mode (FRACTN).....	25
Scaling the Tank Height Indicator (TANK HT) .....	25
Configuring the Lower Display (DISPLAY).....	26
<b>Advanced Features Menu (ADVANCE)</b> -----	<b>28</b>
Advanced Features Menu & Display Messages .....	29
Alarm Output (OUTPUT).....	31
Input Signal Filter (FILTER) .....	32
Volume Display Scaling (VOL SCAL).....	32
Level Input Live Signal Calibration (LVL CAL).....	33
Internal Calibration (ICAL).....	35
Level Input Multipoint Linearization (MULTIPT).....	36
Information (INFO).....	36
Setting Up the Password (PASSWORD).....	37
Locking the Meter.....	37

Making Changes to a Password Protected Meter .....	37
Disabling Password Protection .....	38
<b>OPERATION .....</b>	<b>39</b>
Front Panel Buttons Operation .....	39
Display Measurement Input Current (LOOP $\mu$ A) .....	40
Reset Meter to Factory Defaults .....	41
Factory Defaults & User Settings .....	42
<b>TROUBLESHOOTING .....</b>	<b>43</b>
Troubleshooting Tips .....	43
<b>MOUNTING DIMENSIONS .....</b>	<b>44</b>
<b>QUICK USER INTERFACE REFERENCE .....</b>	<b>46</b>
<b>EC DECLARATION OF CONFORMITY .....</b>	<b>47</b>

## Table of Figures

Figure 1. Connector Board .....	12
Figure 2. Input Connections without Backlight .....	13
Figure 3. Input Connections with Loop-Powered Backlight .....	13
Figure 4. Input Connections with Externally-Powered Backlight .....	14
Figure 5. External Alarm Reset/Acknowledge Connections .....	14
Figure 6. Connection to Device with Internal Pull-Up .....	15
Figure 7. Output Connections .....	15
Figure 8. Enclosure Dimensions – Front View .....	44
Figure 9. Enclosure Dimensions – Side Cross Section View .....	45

## SPECIFICATIONS

Except where noted all specifications apply to operation at +25°C.

### General

<b>DISPLAY</b>	Feet & Inches	0.60" (15.2 mm) high 0 to 399 <sup>FT</sup> 11 <sup>15</sup> / <sub>16</sub> <sup>IN</sup> 7-segment, programmable 1/16 or 1/8 fraction display
	Seven characters (Tag &/or Volume)	0.4" (10.2 mm) high 14-segment, 7-digits
	Tank Level Indicator	20-segments, F (Full) and E (Empty)
	Alarm Indication	HI and LO
	Backlight	White
<b>DISPLAY ASSIGNMENT</b>	Lower display may be assigned to custom unit or tag, volume, volume and tag, percent height, percent height and tag, or off.	
<b>DISPLAY UPDATE RATE</b>	Ambient > -25°C: 2 Updates/Second Ambient < -25°C: 1 Update/5 Seconds	
<b>OVERRANGE AND UNDERRANGE</b>	Level display flashes to 399 <sup>FT</sup> 11 <sup>15</sup> / <sub>16</sub> <sup>IN</sup> Volume display flashes 9999999 if overrange, -9999999 if underrange.	
<b>PROGRAMMING METHOD</b>	Four Through-Glass buttons when cover is installed. Four internal pushbuttons when cover is removed.	
<b>NOISE FILTER</b>	Programmable low (L <sub>□</sub> ), medium (M <sub>□</sub> ), high (H <sub>□</sub> ), or off (□F)	
<b>RECALIBRATION</b>	Recalibration is recommended at least every 12 months.	
<b>PASSWORD</b>	Programmable password restricts modification of programmed settings.	
<b>NON-VOLATILE MEMORY</b>	All programmed settings are stored in non-volatile memory for a minimum of ten years if power is lost.	
<b>NORMAL MODE REJECTION</b>	64 dB at 50/60 Hz	
<b>ENVIRONMENTAL</b>	Operating temperature range: -40 to 75°C Storage temperature range: -40 to 75°C Relative humidity: 0 to 90% non-condensing	
<b>CONNECTIONS</b>	Screw terminals accept 12 to 22 AWG wire	
<b>ENCLOSURE</b>	Explosion-proof die cast aluminum with glass window, corrosion resistant epoxy coating, color: green. NEMA 4X, 7, & 9, IP68. Two 3/4" NPT threaded conduit openings. One 3/4" NPT metal conduit plug with 12 mm hex key fitting installed.	

**MOUNTING** May be mounted directly to conduit. Two slotted flanges for wall mounting or NPS 1½" to 2½" or DN 40 to 65 mm pipe mounting. See Mounting Dimensions on page 44.

**OVERALL DIMENSIONS** 5.65" x 5.25" x 4.86" (W x H x D)  
(144 mm x 133 mm x 124 mm)

**WEIGHT** 5.00 lbs (80 oz, 2.27 kg)

**WARRANTY** 3 years parts and labor

## Input

**ACCURACY** ±0.03% of calibrated span ±1 count

**Input Range** 3 to 24 mA

**MULTI-POINT LINEARIZATION** 2 to 32 points, level and volume independently programmed.

**TEMPERATURE DRIFT** 50 PPM/°C from -40 to 75°C ambient

**CALIBRATION RANGE** An *Error* message will appear if input 1 and input 2 signals are too close together.

*Input Range: 4-20 mA*

*Input 1 & 2 Minimum Span: 0.10 mA*

**MAXIMUM VOLTAGE DROP** *Without Backlight or with Externally-Powered (DC Powered) Backlight: 3.0 VDC @ 20 mA*  
*With Loop-Powered Backlight: 6.0 VDC @ 20 mA*

**EQUIVALENT RESISTANCE** 150 Ω @ 20 mA without loop-powered backlight. 300 Ω @ 20 mA with loop-powered backlight.

**EXTERNALLY POWERED BACKLIGHT** *Voltage Range: 9-36 VDC*

<i>Supply Voltage</i>	9 VDC	12 VDC	24 VDC	36 VDC
<i>Maximum Power</i>	0.2 W	0.25 W	0.5 W	0.75 W

**INPUT OVERLOAD** Over current protection to 2 A max.

## Open Collector Output

**RATING** Isolated open collector, 30 VDC @ 150 mA max.

**ALARM OUTPUT** Assign to level or volume for high or low alarm trip point.

**DEADBAND** 0-100% FS, user selectable

**ACKNOWLEDGE** Front panel ENTER button and external RESET terminals resets output and screen indication.

---

## Product Ratings and Approvals

---

<b>FM</b>	Class I, Division 1, Groups B, C, D Class II, Division 1, Groups E, F, G Class III, Division 1; T6 Class I, Zone 1, AEx d IIC T6 Gb Zone 21, AEx tb IIIC T85°C Ta = -40°C to +75°C Enclosure: Type 4X & IP66 Certificate number: 3048884
<b>ATEX</b>	 II 2 G D Ex d IIC T6 Gb Ex tb IIIC T85°C Db IP68 Ta = -40°C to +75°C Certificate number: Sira 13ATEX1121X
<b>CSA</b>	Class I, Division 1, Groups B, C, D Class II, Division 1, Groups E, F, G Class III, Division 1; T6 Class I, Zone 1, Ex d IIC T6 Ta = -40°C to +75°C Enclosure: Type 4X & IP66 Certificate number: 2605742
<b>IECEX</b>	Ex d IIC T6 Gb Ex tb IIIC T85°C Db IP68 Ta = -40°C to +75°C Certificate number: IECEX SIR 13.0042X

---

### **Special Conditions for Safe Use:**

Use suitably certified and dimensioned cable entry device and/or plug. The equipment shall be installed such that the supply cable is protected from mechanical damage. The cable shall not be subjected to tension or torque. If the cable is to be terminated within an explosive atmosphere, then appropriate protection of the free end of the cable shall be provided.

### **Year of Construction**

This information is contained within the serial number with the first four digits representing the year and month in the YYMM format.

**For European Community:** The YPP6801 must be installed in accordance with the ATEX directive 94/9/EC, and the product certificate Sira 13ATEX1121X.



## Electromagnetic Compatibility

<b>EMISSIONS</b>	EN 61326:2006 Safety requirements for measurement, control, and laboratory use – Industrial Group 1 Class A ISM emissions requirements
Radiated Emissions	Class A
<b>IMMUNITY</b>	EN 61326:2006 Safety requirements for measurement, control, and laboratory use
ESD	±4 kV contact, ±8 kV air
RFI – Amplitude Modulated	80-1000 MHz @ 10 V/m, 1.4-2.0 GHz @ 3 V/m, 2.0-2.7 GHz @ 1 V/m, 80% AM (1 kHz)
EFT	±2 kV DC mains, ±1 kV other
Telco Surge	±1 kV
CRFI	3 V, 0.15-80 MHz, 1 kHz 80% AM

## SAFETY INFORMATION



### WARNINGS

- Read complete instructions prior to installation and operation of the meter.
- Installation and service should be performed only by trained service personnel. Service requiring replacement of internal components must be performed at the factory.
- Disconnect from supply before opening enclosure. Keep cover tight while circuits are alive. Conduit seals must be installed within 18" (450mm) of the enclosure.
- Verify that the operating atmosphere of the meter is consistent with the appropriate hazardous locations certifications.
- If the meter is installed in a high voltage environment and a fault or installation error occurs, high voltage may be present on any lead.

## INSTALLATION

**For Installation in USA:** The YPP6801 must be installed in accordance with the National Electrical Code (NEC) NFPA 70.

**For Installation in Canada:** The YPP6801 must be installed in accordance with the Canadian Electrical Code CSA 22.1. All input circuits must be derived from a CSA approved Class 2 source.

**For European Community:** The YPP6801 must be installed in accordance with the ATEX directive 94/9/EC and the product certificate Sira 13ATEX1121X.



Disconnect from supply before opening enclosure. Keep cover tight while circuits are alive. Conduit seals must be installed within 18" (450mm) of the enclosure.

Wiring connectors are accessed by opening the enclosure. To access electrical connectors, remove the 2 captive screws, then disconnect the ribbon cable from the display module and set the display module aside.

## Unpacking

Remove the meter from box. Inspect the packaging and contents for damage. Report damages, if any, to the carrier.

If any part is missing or the meter malfunctions, please contact your supplier or the factory for assistance.

## Pre-Installed Conduit/Stopping Plug

The YPP6801 is supplied with one pre-installed conduit plug for installations that do not require the use of both conduit entries. The conduit/stopping plug includes an internal hexagonal socket recess for removal. The pre-installed plug and its installation are included in the hazardous area approvals for the YPP6801.



In hazardous areas, conduit and conduit/stopping plugs require the application of non-setting (solvent free) thread sealant. It is critical that all relevant hazardous area guidelines be followed for the installation or replacement of conduit or plugs.

## Mounting

The YPP6801 has two slotted mounting flanges that may be used for pipe mounting or wall mounting. Alternatively, the unit may be supported by the conduit using the conduit holes provided.

Refer to *Mounting Dimensions*, page 44 for details.



**WARNING**

Do not attempt to loosen or remove flange bolts while the meter is in service.

## Cover Jam Screw

The cover jam screw should be properly installed once the meter has been wired and tested in a safe environment. The cover jam screw is intended to prevent the removal of the meter cover in a flameproof environment without the use of tools. Using a M2 hex wrench, turn the screw clockwise until the screw contacts the meter. Turn the screw an additional 1/4 to 1/2 turn to secure the cover. Caution: Excess torque may damage the threads and/or wrench.

## Connections



**WARNINGS**

- Static electricity can damage sensitive components.
- Observe safe handling precautions for static-sensitive components.
- Use proper grounding procedures/codes.
- If the meter is installed in a high voltage environment and a fault or installation error occurs, high voltage may be present on any lead or terminal.

To access the connectors, remove the enclosure cover and unscrew the two captive screws that fasten the display module. Disconnect the ribbon cable and remove the display module. Signal connections are made to a four-terminal connector in the base of the enclosure. Grounding connections are made to the two ground screws provided on the base – one internal and one external.

## Connections (continued)

<b>SIGNAL +</b>	4-20 mA signal input positive terminal connection
<b>SIGNAL -</b>	4-20 mA signal return/negative terminal connection when not using loop powered backlight.
<b>BACKLIGHT +</b>	+9-30 VDC when powering backlight from external supply.
<b>BACKLIGHT -</b>	4-20 mA signal return/negative terminal when using the installed loop powered backlight or ground/negative when powering backlight from external supply.
<b>OUTPUT+</b>	NPN open collector output positive.
<b>OUTPUT-</b>	NPN open collector output negative.
<b>RESET +</b>	Contact closure alarm acknowledge pullup to 3 VDC
<b>RESET-</b>	Contact closure alarm acknowledge ground/negative.

Refer to Figure 1 for terminal positions.



**WARNING** Observe all safety regulations. Electrical wiring should be performed in accordance with all agency requirements and applicable national, state, and local codes to prevent damage to the meter and ensure personnel safety.

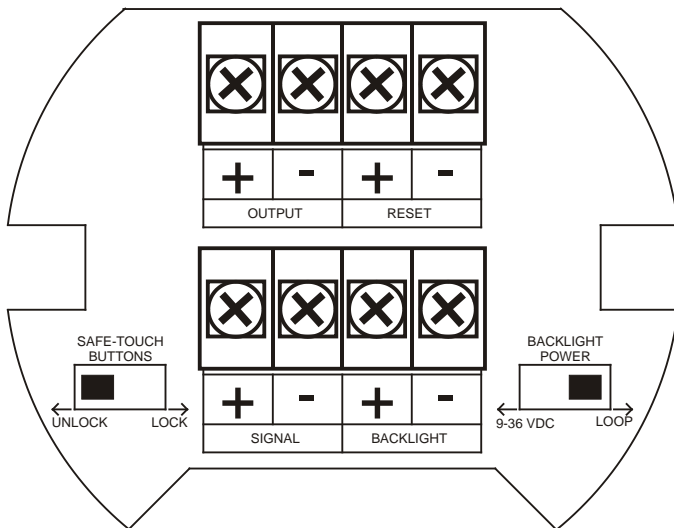
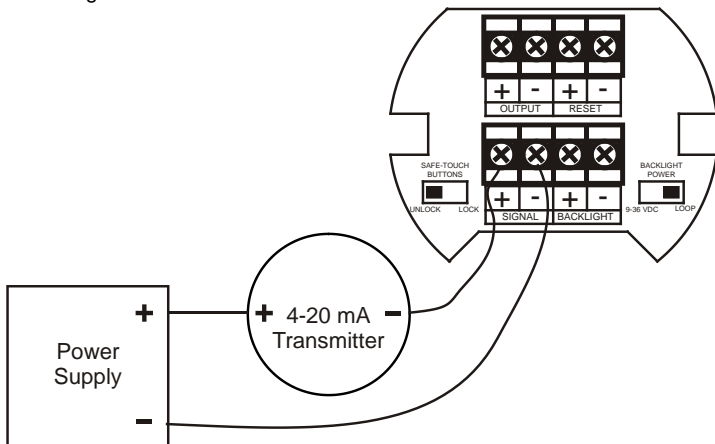

Figure 1. Connector Board

## Input Signal & Backlight Connections

Signal and backlight connections are made to a four-terminal connector mounted in the base of the enclosure. For installations without backlight, only the two signal terminals are connected. The 4-20 mA input with no backlight has a maximum voltage drop of 3 V and is wired as shown in Figure 2. The loop-powered backlight configuration requires a total maximum voltage drop of 6 V. The backlight is recommended for dim lighting conditions and is enabled when wired as shown in Figure 3 or Figure 4.



**Figure 2. Input Connections without Backlight**

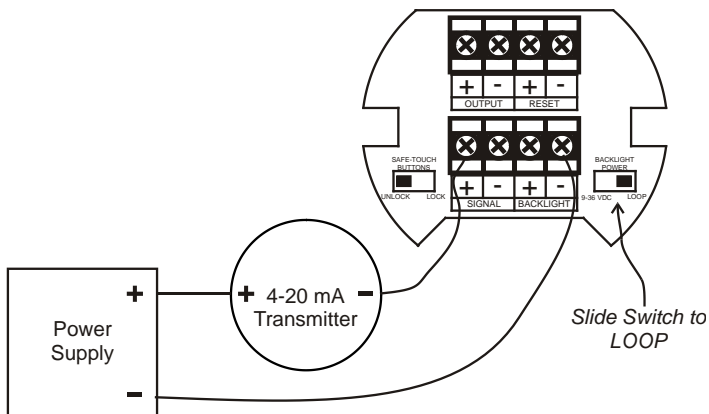

**Figure 3. Input Connections with Loop-Powered Backlight**

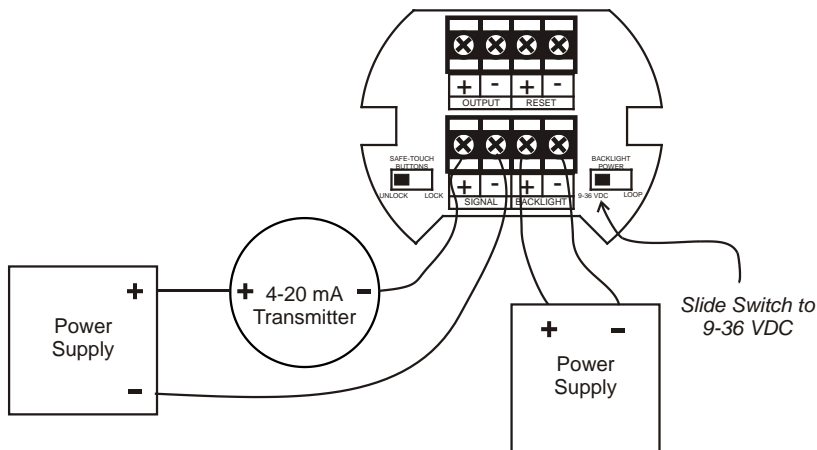
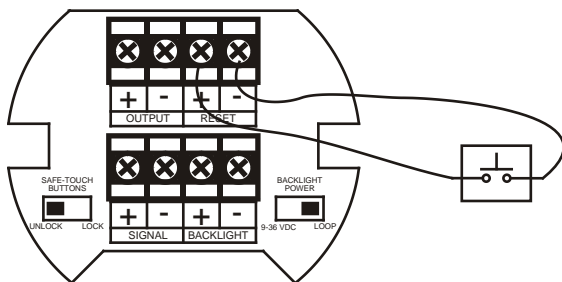

**Figure 4. Input Connections with Externally-Powered Backlight**

It is possible to use the same transmitter (signal loop) power supply for the externally powered backlight. The backlight circuit will draw 25 mA in addition to the loop circuit.

### External Acknowledge Connection

External acknowledge connections are made to two terminals labeled RESET. Connect to a contact closure source such as a relay or a pushbutton as shown in Figure 5.



**Figure 5. External Alarm Reset/Acknowledge Connections**

## Open Collector Output Connections

Output connections are made to two terminals labeled OUTPUT. Connect to an input device such as alarm indicator as shown in Figure 6, or drive a relay as shown in Figure 7.



To avoid damaging the YPP6801's amplifying components, use care not to wire incorrectly or exceed output ratings. A diode, such as 1N4000 series, will provide protection from relay transients.

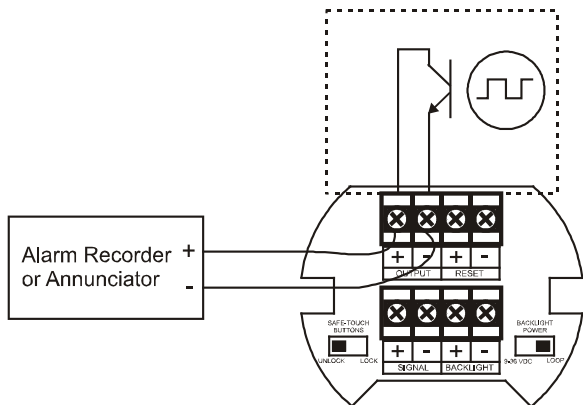

Figure 6. Connection to Device with Internal Pull-Up

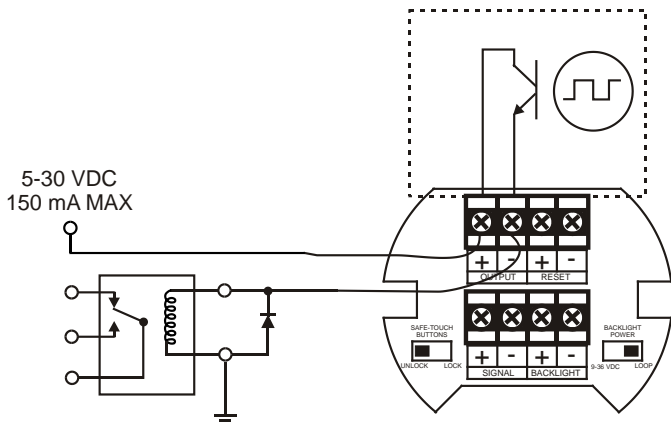

Figure 7. Output Connections

## SETUP AND PROGRAMMING

There is **no need to recalibrate** the meter when first received from the factory. The meter is **factory calibrated** prior to shipment. The calibration equipment is certified to NIST standards

### Overview

Setup and programming is done through the infrared Through-Glass buttons, or using the mechanical buttons when uncovered. There are two slide switches located on the connector board. One is used to select backlight power (if equipped) and the other is to lock or unlock the Through-Glass Buttons.

After all connections have been completed and verified, connect the ribbon cable to the display module, fasten the display module to the base, install enclosure cover, and then apply power.



## Through-Glass Buttons

The YPP6801 is equipped with four sensors that operate as through-glass buttons so that it can be programmed and operated without removing the cover (and exposing the electronics) in a hazardous area. These buttons can be disabled for security by selecting the LOCK setting on the Through-Glass Buttons switch located on the connector board in the base of the enclosure.

### Through-Glass Button Operation

To actuate a button, press and remove one finger to the glass directly over the marked button area. Remove finger to at least 4 inches away from the glass in between button activations. Through-Glass and mechanical buttons may be held to cycle through menus or digits in place of repeatedly pushing a button.

The sensors are disabled when a mechanical button is pressed and will automatically be re-enabled after 60 seconds of inactivity.

### Through-Glass Button Tips and Troubleshooting

The Through-Glass Buttons are designed to filter normal levels of ambient interference and to protect against false triggering, however it is recommended that the Through-Glass Buttons be turned off (slide Through-Glass Buttons switch to OFF) if there is an infrared interference source in line-of-sight to the display or if the buttons are not needed.

Through-Glass Button Tips:

- To the extent possible, install the display facing away from sunlight, windows, reflective objects and any sources of infrared interference.
- Keep the glass window clean.
- Tighten the cover securely.
- Use a password to prevent tampering.
- If the cover has not been installed and secured tightly, it may take a moment for the Through-Glass buttons to properly self calibrate when the cover is tightened.

**IMPORTANT**

Through-Glass buttons will not work if two or more buttons are detected as being pressed simultaneously. As a result, be careful to avoid triggering multiple buttons or reaching across one button location to press another.

## Buttons and Display



Button Symbol	Description
	Menu
	Right Arrow/ Reset
	Up Arrow/ Display
	Enter/ Alarm Acknowledge

Symbol	Description
FT	Feet
IN	Inches and Fractional Inches
F	Tank Full Indicator
E	Tank Empty Indicator
HI	High Alarm
LO	Low Alarm

**Menu Button**

- Press the **Menu** button to enter Programming Mode.
- Press the **Menu** button during Programming Mode to return to the previous menu selections.
- Hold the **Menu** button for 1.5 seconds at any time to exit Programming Mode and return to Run mode.
- Press and hold the **Menu** button for 3 seconds to access the *Advanced* features of the meter.

**Right / Reset Button**

- Press the **Right** arrow button to move to the next digit or decimal position during programming.
- Press **Right** to go backward through most selection menus.

**Up / Display Button**

- Press **Display** when in Run mode to display the loop input value in  $\mu\text{A}$ . The display will time out in 12 seconds. Press **Display** again to resume normal lower display operation (lower display will read **RESUME**).
- Press the **Up** arrow button to scroll forward through the menus, decimal point, or to increment the value of a digit.

**Enter Button**

- Press the **Enter** button to access a menu or to accept a setting.
- Press **Enter** to acknowledge alarm (if enabled).

## Main Menu

The main menu consists of the most commonly used functions: *Setup*, *Advanced*, and *Password*.

Press **MENU** button to enter Programming Mode then press the **Up Arrow** button to scroll through the main menu.

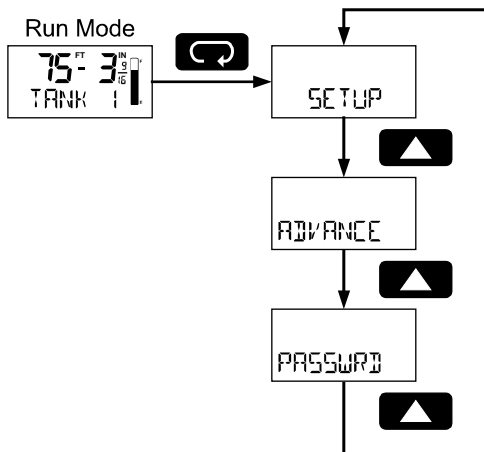

Hold **MENU**, at any time, to exit and return to Run Mode. Changes made to settings prior to pressing **ENTER** are not saved.

Press the **MENU** button during Programming Mode to return to the previous menu selections.

Changes to the settings are saved to memory only after pressing **ENTER**.

The display moves to the next menu every time a setting is accepted by pressing **ENTER**.

## Setting Numeric Values

The numeric values are set using the **RIGHT** and **UP** arrow buttons. Press **RIGHT** arrow to select next digit and **UP** arrow to increment digit.

The digit being changed blinks.

Press the **ENTER** button, at any time, to accept a setting.

Hold **MENU**, at any time, to exit and return to Run Mode. Changes made to settings prior to pressing **ENTER** are not saved.

Press the **MENU** button during Programming Mode to return to return to the previous menu selections.

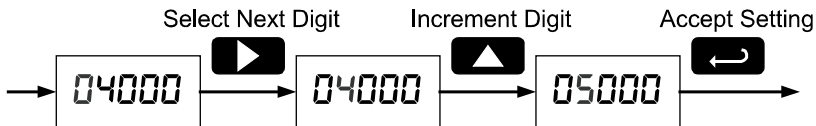

## Setting Up the Meter (SETUP)

The *Setup* menu is used to select:

1. Feet and inches display scale
2. Inch fraction display mode
3. Tank indicator full value
4. Bottom display selection

Press the **ENTER** button to access any menu or press **UP** arrow button to scroll through choices.

Hold **MENU**, at any time, to exit and return to Run Mode. Changes made to settings prior to pressing **ENTER** are not saved.

Press the **MENU** button during Programming Mode to return to return to the previous menu selections.

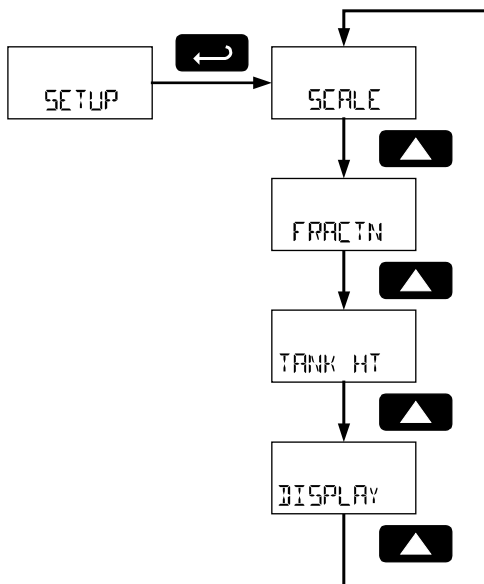

## Setup Menu Display Functions & Messages

The meter displays various functions and messages during setup, programming, and operation. The following table shows the *Setup* menu functions and messages in the order they appear in the menu.

Display	Parameter	Action/Setting
SETUP	<i>Setup</i>	Enter <i>Setup</i> menu
SCALE	<i>Scale</i>	Enter the <i>Scale</i> menu for feet and inches
INPUT 1	<i>Input 1</i>	Set input 1 value in $\mu\text{A}$
DISPLY 1	<i>Display 1</i>	Set display 1 feet and inches
INPUT 2	<i>Input 2</i>	Set input 2 value in $\mu\text{A}$
DISPLY 2	<i>Display 2</i>	Set display 2 feet and inches
SAVE P	<i>Save</i>	Save entered scale parameters
SPN ERR	<i>Span Error</i>	Scale point 1 and 2 span error
FRACTN	<i>Fraction</i>	Enter the <i>Program</i> menu
1/16LH	$1/16^{\text{th}}$	Set display for $1/16^{\text{th}}$ inch fractions
OFF	<i>Off</i>	Turn off inch fraction display
1/8LH	$1/8^{\text{th}}$	Set display for $1/8^{\text{th}}$ inch fractions
TANK HT	<i>Tank height</i>	Enter the <i>Tank Height Indicator</i> menu
DISPLAY	<i>Display</i>	Enter <i>Bottom Display</i> menu
TAG	<i>Tag</i>	Display a custom unit or tag
VOLUME	<i>Volume</i>	Display volume
VOL+TAG	<i>Volume + Tag</i>	Display volume and custom tag
PCT HT	<i>Percent Height</i>	Display percent height
PCT+TAG	<i>Percent Height + Tag</i>	Display percent height and custom tag

For instructions on how to program numeric values, see Setting Numeric Values on page 21.

## Scaling the Meter (SCALE)

The 4-20 mA input is scaled to display the process in feet and inches. To scale the meter, enter the values in micro-amps ( $\mu\text{A}$ ) for input 1, and then the corresponding feet and inches display value. Do the same for input 2.

*Note:  $4,000 \mu\text{A} = 4 \text{ mA}$ ,  $20,000 \mu\text{A} = 20 \text{ mA}$*

After entering the display 2 value, confirm the new scale by pressing **ENTER** at the Save menu.

A signal source is not needed to scale the meter; simply program the inputs and corresponding display values.

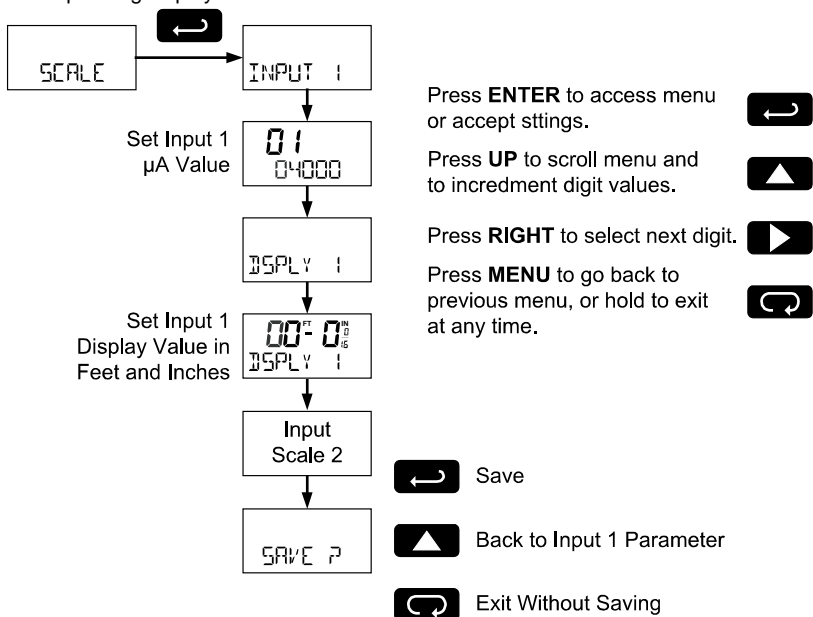

### Programming Note

When programming the left-most digit of the feet and inches display during *Display 1* and *Display 2* programming, a zero is represented by  $\frac{1}{8}$ . This left most zero character will not display during operation, and is only used when programming the left-most display digit.

For instructions on using multipoint scaling, see Level Input Multipoint Linearization (MULTIPOINT) on page 36.

For instructions on how to program numeric values see *Setting Numeric Values*, page 21.



### Minimum Input Span

The minimum input span is the minimum difference between input 1 and input 2 signals required to complete the calibration or scaling of the meter. The minimum span is 100  $\mu$ A.

### Scale Error Message (SPN ERR)

If the minimum span is not maintained, the meter will show a span error (SPN ERR) and revert to input 2, allowing the appropriate input signals to be applied.

### Selecting Inch Fraction Display Mode (FRACTN)

The display may be programmed to display fractions of an in 1/8<sup>th</sup> or 1/16<sup>th</sup> increments, or to show no fraction.

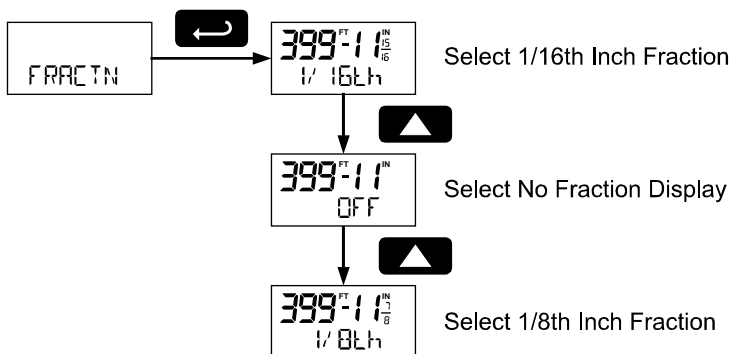

### Scaling the Tank Height Indicator (TANK HT)

The display includes a 20-segment tank height indicator. This menu sets full value, in feet and inches, for the tank height indicator.

This value may differ from the 20 mA (20,000  $\mu$ A) full-scale value programmed in the *Scale* menu. This is ideal for level transmitters that output less than 20 mA at the maximum height of the tank or pit.

As an example, when using a level transmitter that outputs 20 mA at 250 feet, the tank height indicator may be set for 100 feet, 0 inches. At 100 feet 0 inches on the display, the tank height indicator will show as full, even though the input is not 20 mA.

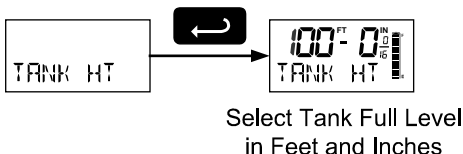

## Configuring the Lower Display (DISPLAY)

The lower display may be configured to display a custom tag (TAG), volume (VOLUME), volume and tag (VOL+TAG), percent of full height (PCT HT), or percent of full height and tag (PCT+TAG), or be blank (OFF).

A custom tag may be up to seven alphanumeric characters programmed for identification (e.g. TANK 3) or for engineering units (e.g. GALLONS).

Volume is a separate, second scale of the input process variable. This is configured in Volume Display Scaling (VOLSCALE) on page 32.

Percent full height shows the percent full of the tank height level indicator programmed in the Scaling the Tank Height Indicator (TANK HT) menu, on page 25.

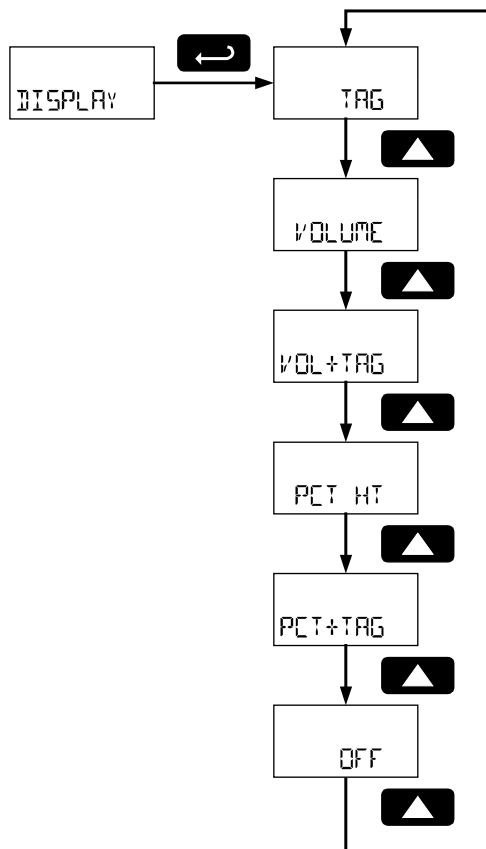

## Setting the TAG (TAG)

Any bottom display setting that includes a tag will require the tag to be entered.

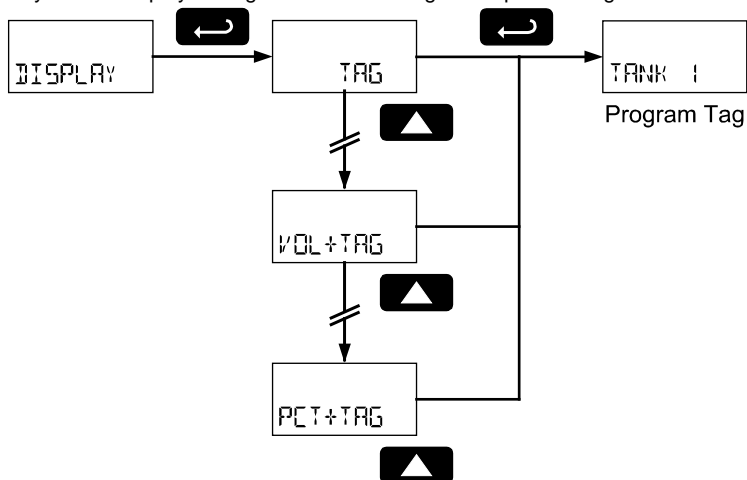

The fully alphanumeric values for the tag are set using the **RIGHT** button to select the digit, the **UP** and **RIGHT** arrow buttons to select the digit reading, and the **ENTER** button to confirm and select the next digit.

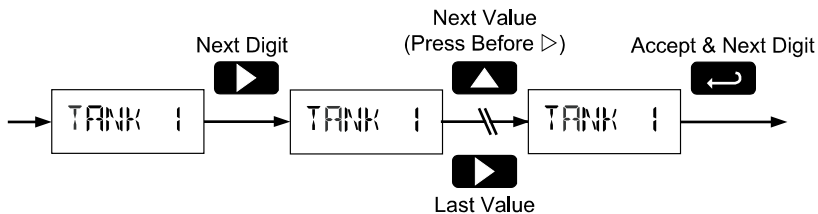

## Advanced Features Menu (ADVANCE)

To simplify the setup process, functions not needed for most applications are located in the *Advanced* features menu. Access the Advanced features menu by pressing **ENTER** at the *Advance* menu in the Main Menu defined on page 20.

The *Advanced* menu is used to select:

1. Open collector output configuration (OUTPUT)
2. Input filter (FILTER)
3. Volume display scale (VOLSCALE)
4. Live signal level display calibration (LVL CAL)
5. Internal Calibration (ICAL)
6. Multipoint linearization for level (MULTIPT)
7. Meter system information display (INFO)

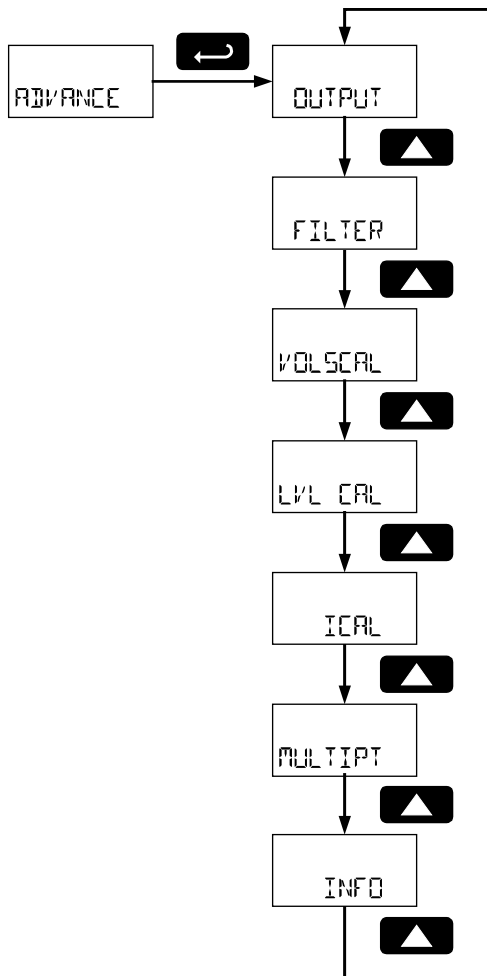

## Advanced Features Menu & Display Messages

The following table shows the *Advanced* features menu functions and messages in the order they appear in the menu.

Display	Parameter	Action/Setting
OUTPUT	<i>Output</i>	Enter output menu
OFF	<i>Off</i>	Disable output
ALARM	<i>Alarm Output</i>	Enter alarm output menu
LEVEL	<i>Level Alarm</i>	Assign alarm output to level
SET	<i>Set Point</i>	Set alarm set point
RESET	<i>Reset Point</i>	Set alarm reset point
VOLUME	<i>Volume Alarm</i>	Assign alarm output to volume
FILTER	<i>Filter</i>	Set noise filter
LO	<i>Filter Low</i>	Set noise filter to low setting
MED	<i>Filter Medium</i>	Set noise filter to medium setting
HI	<i>Filter High</i>	Set noise filter to high setting
OFF	<i>Filter Off</i>	Disable noise filter
VOLSCALE	<i>Volume Scale</i>	Scale the volume display
NO PTS	<i>Number of Points</i>	Set the number of points for volume scaling
INPUT 1	<i>Input 1</i>	Set volume input 1 on the level display
DISPLY 1	<i>Display 1</i>	Set volume display 1
INPUT 2	<i>Input 2</i>	Set volume input 2 on the level display
DISPLY 2	<i>Display 2</i>	Set volume display 2
SAVE P	<i>Save</i>	Save entered volume scale parameters
LVL CAL	<i>Level Calibration</i>	Calibrate the level display
INPUT 1	<i>Input 1</i>	Calibrate input 1 value
DISPLY 1	<i>Display 1</i>	Set display 1 feet and inches
INPUT 2	<i>Input 2</i>	Calibrate input 2 value
DISPLY 2	<i>Display 2</i>	Set display 2 feet and inches
SAVE P	<i>Save</i>	Save entered calibration parameters
ICAL	<i>Internal Calibration</i>	Enter internal reference calibration

Display	Parameter	Action/Setting
4mA	4 mA	Calibrate input at 4 mA
20mA	20 mA	Calibrate input at 20 mA
ERRSPAN	<i>Error Span</i>	Error with calibration point 1 and 2 span
MULTIPT	<i>Multipoint</i>	Set level display multipoint linearization
DISABLE	<i>Disable</i>	Disable multipoint linearization
ENABLE	<i>Enable</i>	Enable multipoint linearization
INFO	<i>Meter Information</i>	Show software number and version, or reset to factory defaults
SOFT	<i>Software</i>	Software number
VERSION	<i>Software Version</i>	Software version
DFLTSP	<i>Reset Defaults</i>	Restore factory default parameter settings

For instructions on how to program numeric values, see Setting Numeric Values on page 21.

## Alarm Output (OUTPUT)

The YPP6801 is equipped with an NPN open collector output that may be set up for high or low alarm trip point based on the feet and inches level display (LEVEL) or the volume scale (VOLUME). The output may be disabled by selecting OFF.

When the alarm is enabled for level, the HI and LO symbols are used and will flash, accompanied by a flashing level display. A tank height indicator segment will flash at the level the alarm is set to while the level indicator is at or above the alarm point.

When the alarm is enabled for volume, the HI and LO symbols are used and will flash, accompanied by a flashing bottom display.

To set a high alarm, program the set point above the reset point.

To set a low alarm, program the set point below the reset point.

To acknowledge an alarm, press the **ENTER** button once for acknowledge prompt and a second time to confirm. Acknowledging an alarm will turn off the alarm output and stop the display from flashing. The HI or LO symbol will remain until the alarm condition is cleared.

The alarm status will show on the display even if the output is not wired.

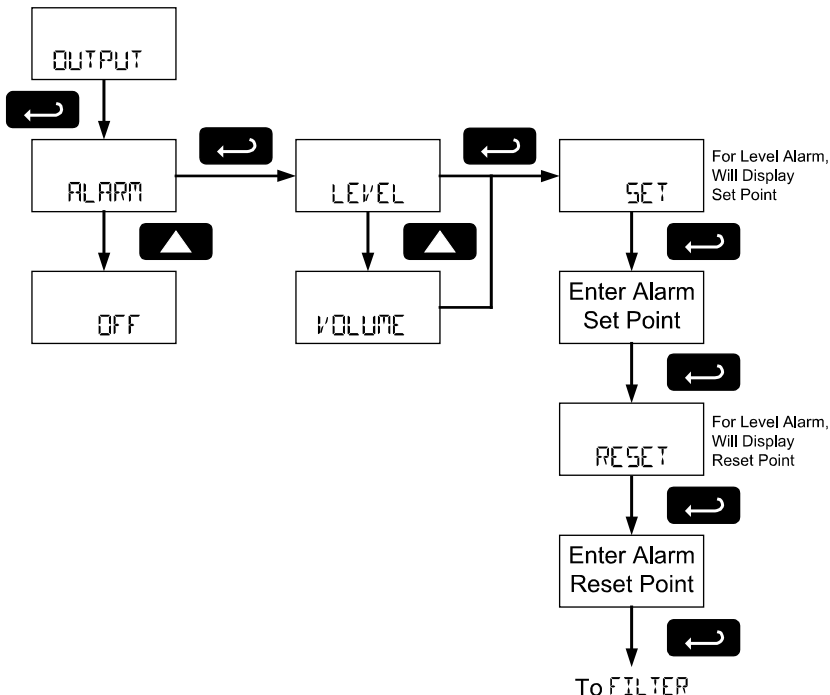

## Input Signal Filter (FILTER)

The noise filter is available for unusually noisy signals that cause an unstable process variable display. The noise filter averages the input signal over a certain period. The filter level can be set to low (L), medium (M), high (H), or off (OFF). The higher the filter setting, the longer the averaging time and so the longer the display may take to find its final value.

The filter contains a noise filter bypass feature so that while small variations in the signal will be filtered out, large, abrupt changes to the input signal are displayed immediately.

## Volume Display Scaling (VOLSCALE)

Volume may be scaled as a function of the feet and inches level display. It may use up to 32-point linearization. The multi-point linearization can be used to linearize the display for non-linear signals such as those from level transmitters used to measure volume in odd-shaped tanks.

To display the volume, select a bottom display including the volume display in the *Display* menu as shown in *Configuring the Lower Display (DISPLAY)* on page 26.



To scale the volume display, enter the level in feet and inches for input 1, and then the corresponding volume display value. Do the same for input 2.

After entering the display 2 value, confirm the new volume scale by pressing **ENTER** at the Save menu.

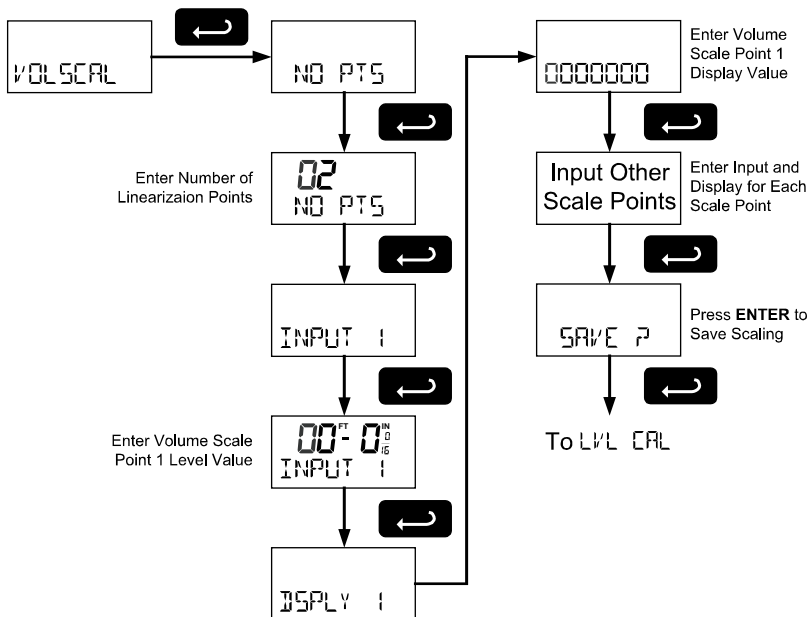

### Level Input Live Signal Calibration (LVL CAL)

The meter can be calibrated using a current source instead of scaling. This process will override previously programmed scaling of the feet and inches display.

The use of a calibrated signal source is strongly recommended.

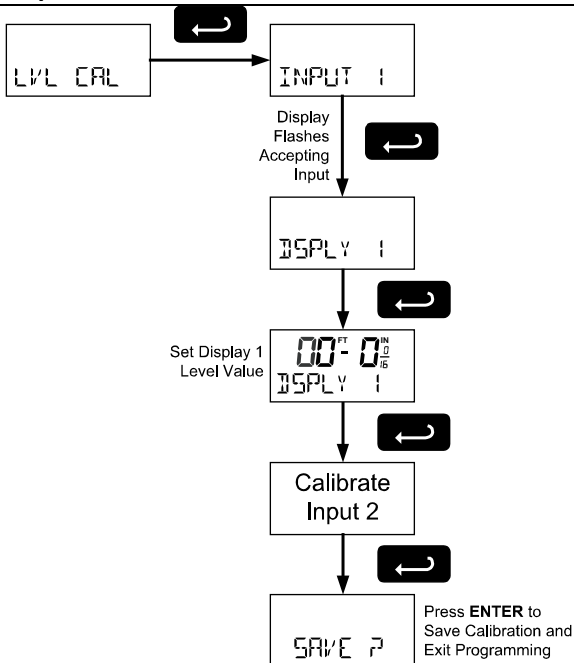

## Internal Calibration (ICAL)

There is **no need to recalibrate** the meter when first received from the factory. The meter is **factory calibrated** prior to shipment. The calibration equipment is certified to NIST standards

The internal calibration is the meter's master calibration that makes scaling the meter without a signal source possible. Use of a calibrated signal source is necessary to perform an internal calibration of the meter. Check calibration of the meter at least every 12 months. Incorrect calibration will affect the ability of the meter to properly read, scale, and display the input.

### Notes:

The signal source must have a full-scale accuracy of 0.002% or better between 4 and 20 mA in order to maintain the specified accuracy of the meter.

Allow the meter to warm up for at least 15 minutes before performing the calibration procedure.

Press and hold the **MENU** button for 5 seconds to enter the *Advanced* features menu. Press the **UP** arrow button to scroll to the *Internal Calibration* menu (ICAL) and press **ENTER**.

The meter displays 4 mR. Apply a 4.000 mA signal and press **ENTER**. The display flashes for a moment while the meter is accepting the signal.

After the signal is accepted, the meter displays 20 mR. Apply a 20.000 mA signal and press **ENTER**. The display flashes for a moment while the meter is accepting the signal.

### Calibration Error Message (ERRSPAN)

An error message indicates that the calibration process was not successful. After the error message is displayed, the meter will revert to the 4 mR calibration menu. The error message might be caused by inadvertently leaving the signal at the previous level or not maintaining the minimum span. Press the **MENU** button to cancel the current calibration process if necessary.

## Level Input Multipoint Linearization (MULTIPT)

This menu enables multipoint linearization for scaling and calibrating of the level display.

Setting **MULTIPT** to **ENABLE** will alter the level display *Scaling* (See *Scaling the Meter (SCALE)* on page 24) and *Level Calibration* (See *Level Input Live Signal Calibration (LVL CAL)* on page 33) menus to include a *Number of Points (NOPTS)* parameter before entering *Input 1*.

32-point linearization can be used to linearize the display for non-linear signals.

## Information (INFO)

The *Information* menu shows the software identification number and version number. To determine the software version of a meter:

Go to the *Information* menu (**INFO**) and press **ENTER** button.

Continue pressing **ENTER** to scroll through the software release number and software version.

Following the information display, the meter will exit the *Advanced* features menu and return to run mode.

## Setting Up the Password (PASSWORD)

The *Password* menu is used to program a five-digit password to prevent unauthorized changes to the programmed parameter settings. A password protected meter will display **LOCKED** when the **MENU** button is pressed.

### Locking the Meter

Enter the *Password* menu and program a five-digit password.

For instructions on how to program numeric values see Setting Numeric Values, page 21.

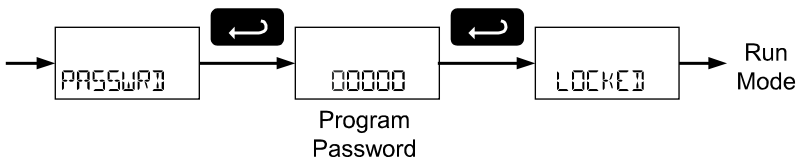

Record the password for future reference. If appropriate, it may be recorded in the space provided.

Model:	
Serial Number:	
Password:	— — — — —

## Making Changes to a Password Protected Meter

If the meter is password protected, the meter will display the message **LOCKED** when the Menu button is pressed. Press the Enter button while the message is being displayed and enter the correct password to gain access to the menu. After exiting the programming mode, the meter returns to its password protected condition.

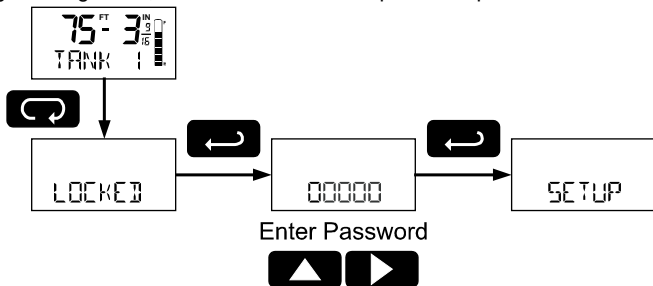

## Disabling Password Protection

To disable the password protection, access the *Password* menu and enter the correct password, as shown below.

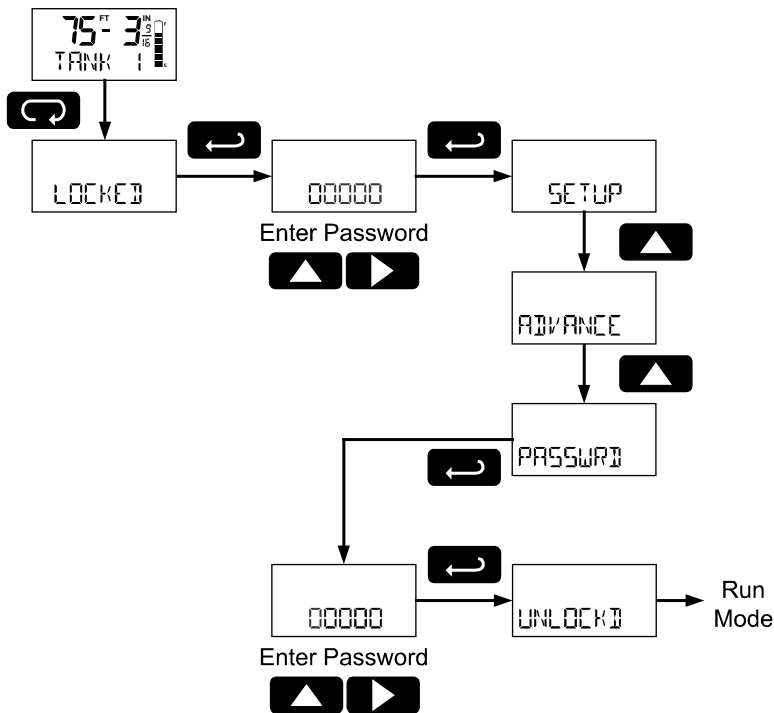

If the correct five-digit password is entered, the meter displays the message `UNLOCKED` (*unlocked*) and the protection is disabled until a new password is programmed.





If the password entered is incorrect, the meter displays the message `LOCKED` and returns to Run Mode. To try again, repeat the above procedure.

### Did you forget the password?

The password may be disabled by entering a master password. If you are authorized to make changes, enter the master password 50865 to unlock the meter.

## OPERATION

### Front Panel Buttons Operation

Button Symbol	Description
	Press to Enter or Exit Programming Mode
	Used During Programming Mode Only
	Press to Display Input Current in $\mu A$ Press to Resume Run Mode in Lower Display <i>Note: 1,000 <math>\mu A</math> = 1 mA</i>
	Press to Acknowledge Alarm (if Enabled)

## Display Measurement Input Current (LOOP $\mu$ A)

The measured input loop current may be displayed on the lower display. This is most often used to troubleshoot the installation.

To display the measured input loop current, press the **DISPLAY** button. The meter will display LOOP  $\mu$ A, followed by the measured input current in micro-amps ( $\mu$ A). The current display will remain for 10 seconds, and then the lower display will return to the normal run mode lower display as programmed in Configuring the Lower Display (DISPLAY) on page 26.

*Note:*  $1,000 \mu\text{A} = 1 \text{ mA}$

*Example:*  $4,000 \mu\text{A} = 4 \text{ mA}$

$20,000 \mu\text{A} = 20 \text{ mA}$

Press **DISPLAY** while displaying the input current to return to the normal operation. The meter will display RESUME followed by the run mode lower display.

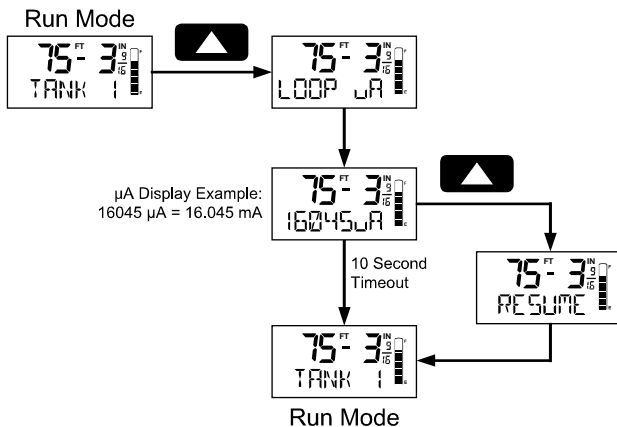



## Reset Meter to Factory Defaults

When the parameters have been changed in a way that is difficult to determine what's happening, it might be better to start the setup process from the factory defaults.

Instructions to load factory defaults:

Enter the *Advanced* features menu.

Press and hold **RESET** button when `INFO` is shown. For information on navigating to the *Information* menu, refer to *Advanced Features Menu* on page 28.

Press **ENTER** when `DEFAULTS?` prompt is flashing.

Note: If **ENTER** is not pressed within three seconds, the prompt will stop flashing return to run mode.

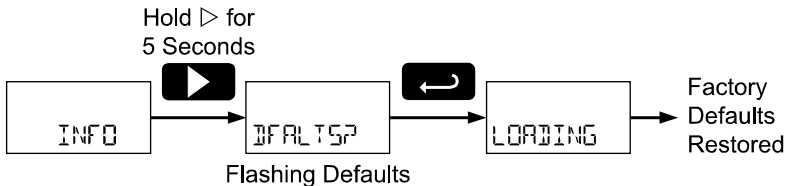

## Factory Defaults & User Settings

The following table shows the factory setting for most of the programmable parameters on the meter. Next to the factory setting, the user may record the new setting for the particular application.

Model: \_\_\_\_\_ S/N: \_\_\_\_\_ Date: \_\_\_\_\_

Parameter	Display	Default Setting	User Setting
<b>Basic Setup</b>			
Input 1	INPUT 1	4.000 mA	
Display 1	DISP L Y 1	00 <sup>ft</sup> 00 <sup>in</sup> 0/16	
Input 2	INPUT 2	20.00 mA	
Display 2	DISP L Y 2	100 <sup>ft</sup> 00 <sup>in</sup> 0/16	
Fraction	FRACTN	1/16th	
Tank Indicator Height	TANK HT	100 <sup>ft</sup> 00 <sup>in</sup> 0/16	
Display	DISP L A Y	Tag	
Tag	TAG	TANK 1	
<b>Advanced Features</b>			
Output	OUTPUT	Off	
Filter	FILTER	Low	
Volume Scale Number of Points	NO PTS	02	
Volume Scale Input 1	INPUT 1	00 <sup>ft</sup> 00 <sup>in</sup> 0/16	
Volume Display 1	DISP L Y 1	0	
Volume Scale Input 2	INPUT 2	100 <sup>ft</sup> 00 <sup>in</sup> 0/16	
Volume Display 2	DISP L Y 2	100,000	
Multipoint	MULTIPT	Disable	
<b>Password</b>			
Password	PASSWRD	00000 (unlocked)	

## TROUBLESHOOTING

The rugged design and the user-friendly interface of the meter should make it unusual for the installer or operator to refer to this section of the manual. If the meter is not working as expected, refer to the recommendations below.

### Troubleshooting Tips

Symptom	Check/Action
No display or faint display	Check input signal connections. Perform hard reset by shorting S+ and S-terminals.
Level display unsteady	Increase filter setting in <i>Advanced</i> menu.
Meter displays error message during calibration (ERRRR)	Check signal connections. Verify minimum input span requirements
Lever display flashing 399 <sup>ft</sup> 11 <sup>in</sup> .	Check input signal and scaling within range of 399 <sup>ft</sup> 11 <sup>in</sup> .
Meter flashes 9999999 or -999999	Check level display within volume scale range of 9999999 and -999999.
Display response is too slow	Check filter setting to see if it can be lowered to L□ or □FF.
If the display locks up or the meter does not respond at all	Perform hard reset by shorting S+ and S-terminals.
Backlight does not appear.	Backlight is intended for viewing assistance in dim lighting conditions. It may not be noticeable under good lighting conditions. Check connections are as shown in Figure 3 or Figure 4 on page 13.
Other symptoms not described above	Call Technical Support for assistance.
Through-Glass buttons do not respond	Mechanical buttons may have been pushed. The Through-Glass buttons will be re-enabled automatically 60 seconds after the last button push. If slide switch on connector board is in Lock position, switch to Unlock. Sunlight can interfere with the sensors. It is recommended to shield the window from sunlight while operating the buttons by standing so as to block direct sunlight.

## MOUNTING DIMENSIONS

All units: inches [mm]

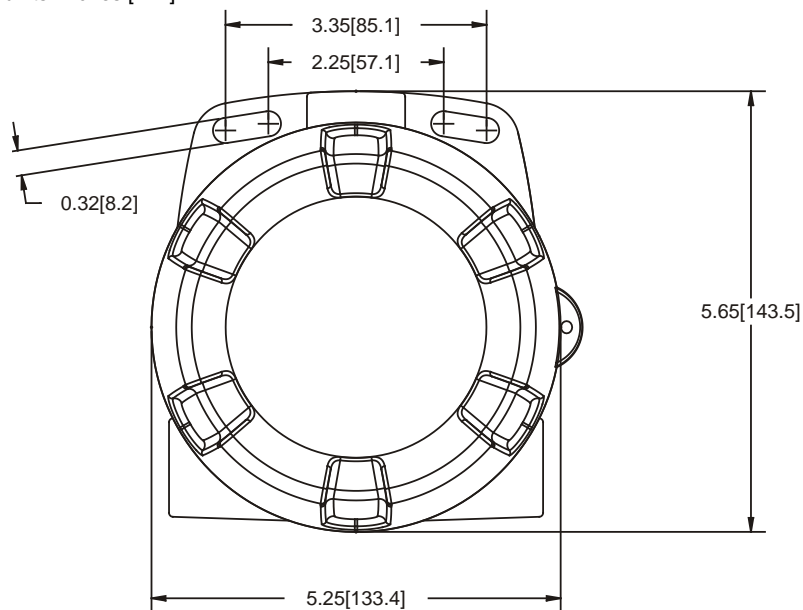

**Figure 8. Enclosure Dimensions – Front View**

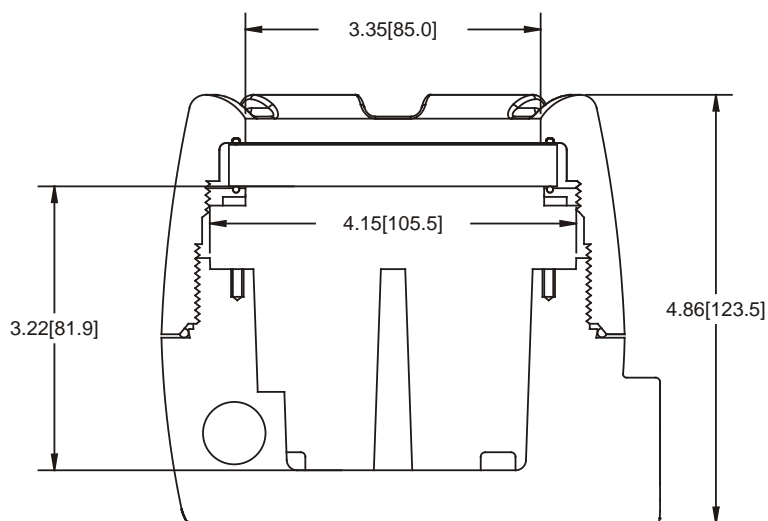
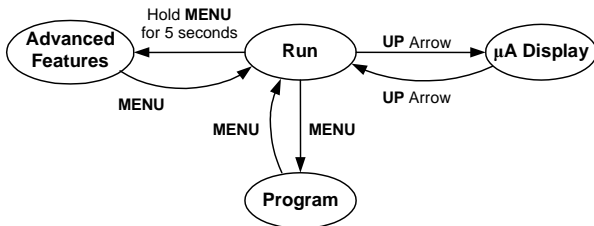

**Figure 9. Enclosure Dimensions – Side Cross Section View**

## QUICK USER INTERFACE REFERENCE

Pushbutton	Function
<b>MENU</b>	Go to programming mode or leave programming. Hold for 5 seconds to enter <i>Advanced</i> feature menu directly.
<b>RIGHT Arrow</b>	Move to next digit. Go to previous menu or alphanumeric character selection
<b>UP Arrow</b>	Move to next selection or increment digit. Go to or cancel $\mu\text{A}$ display mode.
<b>ENTER</b>	Accept selection/value and move to next selection. Acknowledge alarms.

### Operational Modes



### Main Menu

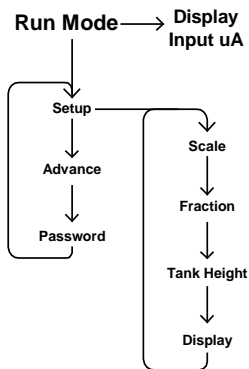

### Advanced Menu

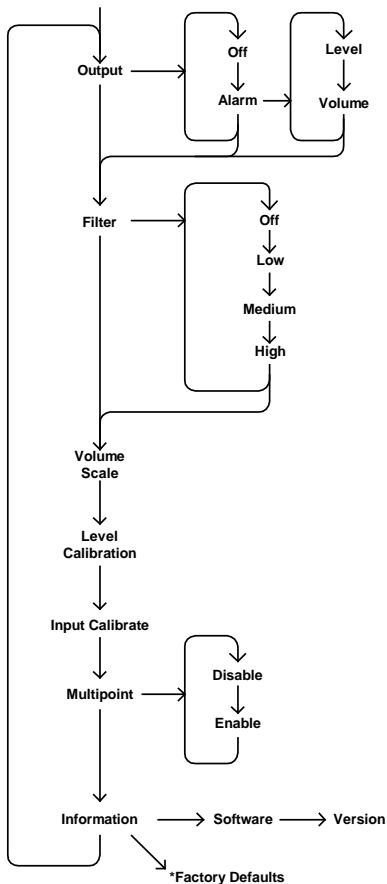

\*Access by holding **Right/Reset** for 3 seconds

# YOKOGAWA

## EC DECLARATION OF CONFORMITY

Issued in accordance with ATEX Directive 94/9/EC

Manufacturer: Yokogawa Corporation of America  
2 Dart Road

Newnan, Georgia 30265 USA

Device: YPP6801 Series Process Meter

Notified Body: Sira Certification Service, notified body no. 0518  
Rake Lane, Eccleston, Chester, CH4 9JN, England

EC Type Examination Certificate: Sira 13ATEX1121X

Quality Assurance Notification No.: ITS12ATEXQ7640

### Compliance with Standards:

EN 60079-0:2009

EN 60079-1:2007

EN 60079-31:2008

EN 61326:2006

IEC 61010-1:2010 & EN 61010-1:2010, including Group and National Differences as they apply for AU, CA, US and KR

### Product Markings:

 II 2 G D

Ex d IIC T6 Gb

Ex tb IIIC T85°C Db IP68

Tamb -40°C to +75°C

### Community Directives:

94/9/EC ATEX Directive

2004/108/EC EMC Directive

Company: Yokogawa Corporation of America

Date: 6/6/2013









YOKOGAWA 