

Temposonics®

Magnetostrictive Linear Position Sensors

ER CANopen Data Sheet

- Compact sensor model
- Operating temperature up to +75 °C (+167 °F)
- Ideal for flexible mounting

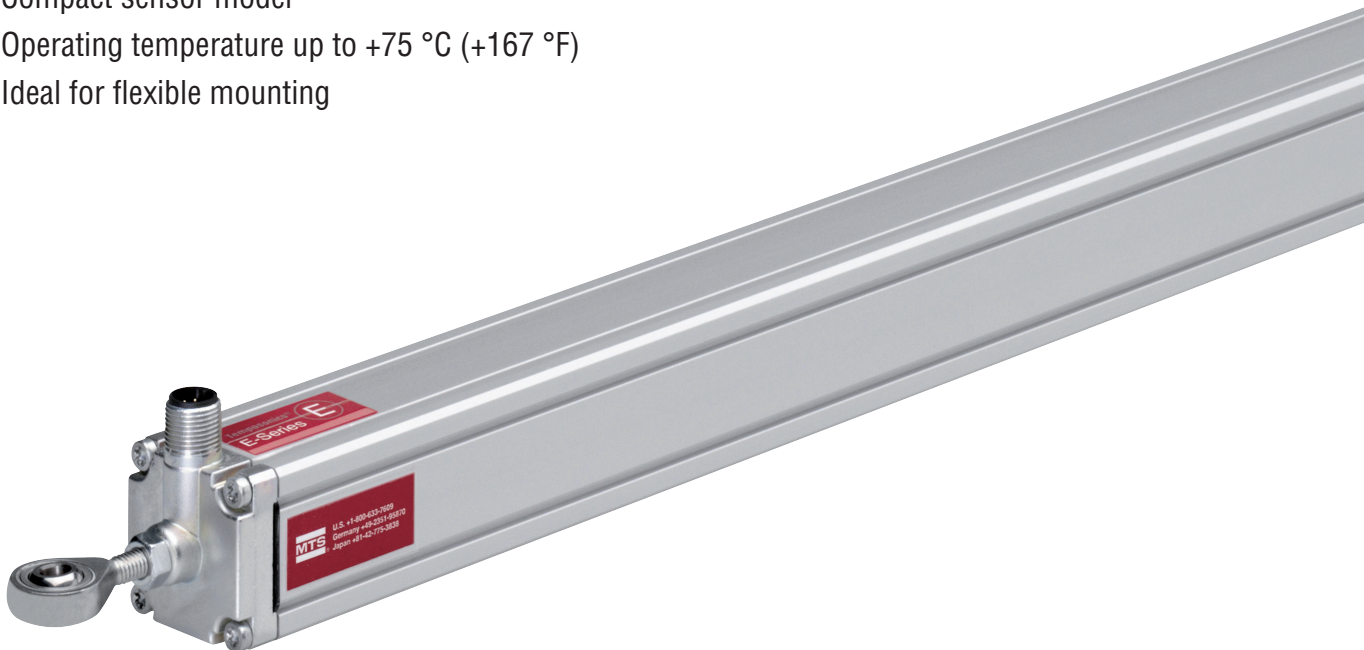

MEASURING TECHNOLOGY

The absolute, linear position sensors provided by MTS Sensors rely on the company's proprietary Temposonics® magnetostrictive technology, which can determine position with a high level of precision and robustness. Each Temposonics® position sensor consists of a ferromagnetic waveguide, a position magnet, a strain pulse converter and supporting electronics. The magnet, connected to the object in motion in the application, generates a magnetic field at its location on the waveguide. A short current pulse is applied to the waveguide. This creates a momentary radial magnetic field and torsional strain on the waveguide. The momentary interaction of the magnetic fields releases a torsional strain pulse that propagates the length of the waveguide. When the ultrasonic wave reaches the end of the waveguide it is converted into an electrical signal. Since the speed of the ultrasonic wave in the waveguide is precisely known, the time required to receive the return signal can be converted into a linear position measurement with both high accuracy and repeatability.

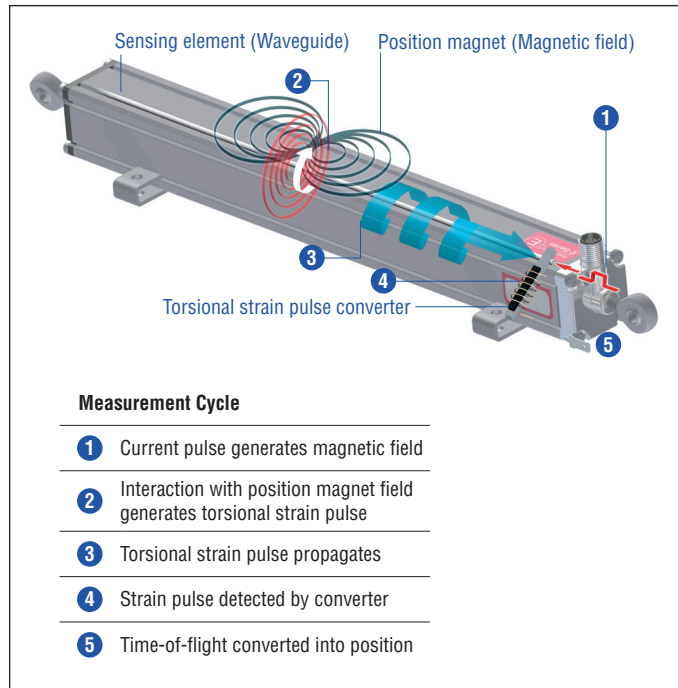

Fig. 1: Time-of-flight based magnetostrictive position sensing principle

ER SENSOR

Robust, non-contact and wear free, the Temposonics® linear position sensors provide the best durability and precise position measurement feedback in harsh industrial environments. Measurement accuracy is tightly controlled by the quality of the waveguide manufactured exclusively by MTS Sensors.

The Temposonics® ER has an aluminum rod-and-cylinder design where the rod can extend and retract from the sensor housing to measure linear position. Inside, a magnet is secured to the end of the rod and remains protected within the sensor electronics housing. Accessory rod ends are available for attaching the rod to the machine's moving part. The rod-and-cylinder sensor design can be installed in any orientation, and provides a convenient and versatile position feedback solution. Typical fields of applications are printing and paper industry, machine tools and plastics industry as well as control systems.



Fig. 2: Typical application: Paper industry

TECHNICAL DATA

Output	
Interface	CAN System ISO 11898
Data protocol	CANopen: CIA Standard DS 301 V3.0 / Encoder Profile DS 406 V3.1
Baud rate, kBit/s	1000 800 500 250 125
Cable length, m	< 25 < 50 < 100 < 250 < 500
Measured value	Position
The sensor will be supplied with ordered baud rate, changeable by customer via LSS	
Measurement parameters	
Resolution	10 µm, 20 µm
Cycle time	1 ms
Linearity	≤ ±0.02 % F.S. (minimum ±60 µm)
Repeatability	≤ ±0.005 % F.S. (minimum ±20 µm)
Operating conditions	
Operating temperature	-40...+75 °C (-40...+167 °F)
Humidity	90 % rel. humidity, no condensation
Ingress protection ^{1,2}	IP67 (if mating connectors are correctly fitted)
Shock test	100 g (single shock) IEC standard 60068-2-27
Vibration test	5 g / 10...2000 Hz IEC standard 60068-2-6 (resonance frequencies excluded)
EMC test	Electromagnetic emission according to EN 61000-6-3 Electromagnetic immunity according to EN 61000-6-2 The sensor meets the requirements of the EC directives and is marked with CE .
Magnet movement velocity	≤ 5 m/s
Design / Material	
Sensor electronics housing	Aluminum
Guided driving rod	Aluminum
Stroke length	50...1500 mm (2...60 in.)
Mechanical mounting	
Mounting position	Any
Mounting instruction	Please consult the technical drawings and the brief instructions (document number: 551684)
Electrical connection	
Connection type	M12 (5 pin) male connector
Operating voltage	+24 VDC (-15 / +20 %); UL recognition requires an approved power supply with energy limitation (UL 61010-1), or Class 2 rating according to the National Electrical Code (USA) / Canadian Electrical Code.
Ripple	≤ 0.28 V _{pp}
Current consumption	40...60 mA (depending on stroke length)
Dielectric strength	500 VDC (DC ground to machine ground)
Polarity protection	Up to -30 VDC
Overvoltage protection	Up to 36 VDC

1/ The IP rating is not part of the UL recognition

2/ The IP rating IP67 is only valid for the sensor electronics housing, as water and dust can get inside the profile

TECHNICAL DRAWING

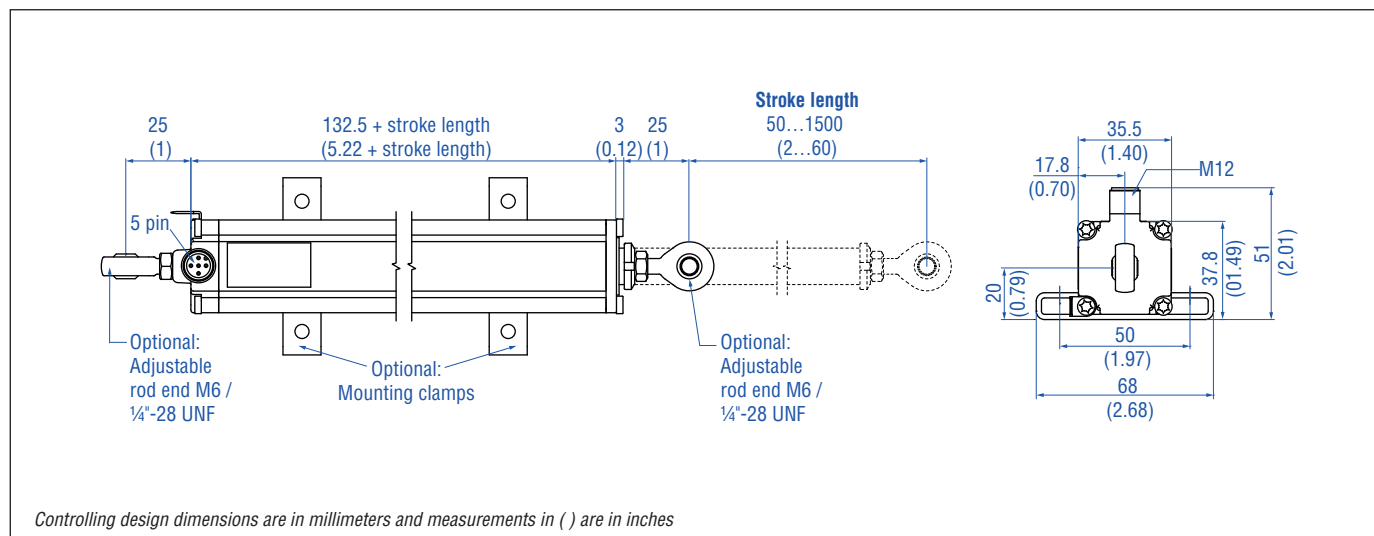

CONNECTOR WIRING

D34

M12 A-coded	Pin	Function
	1	Shield
	2	+24 VDC (-15 / +20 %)
	3	DC Ground (0 V)
	4	CAN_H
	5	CAN_L

FREQUENTLY ORDERED ACCESSORIES – Additional options available in our [Accessories Guide](#)  [551444](#)

Cable connectors³ **Cord sets**

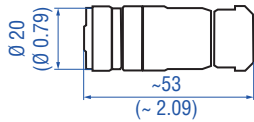
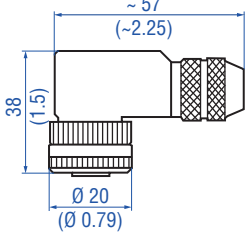
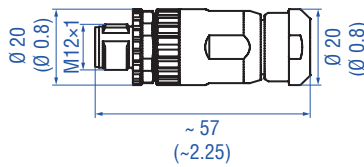
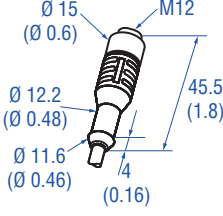
 <p>Ø 20 (Ø 0.79) ~53 (~2.09)</p>	 <p>~57 (~2.25) 38 (1.5) Ø 20 (Ø 0.79)</p>	 <p>Ø 20 (Ø 0.8) M12x1 ~57 (~2.25) Ø 20 (Ø 0.8)</p>	 <p>Ø 15 (Ø 0.6) M12 Ø 12.2 (Ø 0.48) Ø 11.6 (Ø 0.46) 45.5 (1.8) 1/4 (0.16)</p>
<p>M12 (5 pin) female, straight Part no. 370 677</p> <p>Housing: GD-Zn, Ni / IP67 Termination: Screw; max. 1.5 mm² Contact insert: CuZn Operating temperature: -30...+85 °C (-22...+185 °F) Cable Ø: 4...8 mm (0.16...0.31 in.) Fastening torque: 0.6 Nm</p>	<p>M12 (5 pin) female, angled Part no. 370 678</p> <p>Housing: GD-Zn, Ni / IP67 Termination: Screw; max. 0.75 mm² Contact insert: CuZn Operating temperature: -25...+85 °C (-13...+185 °F) Cable Ø: 5...8 mm (0.2...0.31 in.) Fastening torque: 1 Nm</p>	<p>M12 (5 pin) male, straight Part no. 561 665</p> <p>Housing: GD-Zn, Ni / IP67 Termination: Screw; max. 1.5 mm² Contact insert: CuZn Operating temperature: -30...+85 °C (-22...+185 °F) Cable Ø: 4...8 mm (0.16...0.31 in.) Fastening torque: 0.6 Nm</p>	<p>M12 (5 pin) female, straight Part no. 370 673</p> <p>Ingress protection: IP67 Cable: Shielded, pigtail end Cable length: 5 m (16.4 ft.)</p>

Cord sets **Connection accessories** **Mounting clamp**

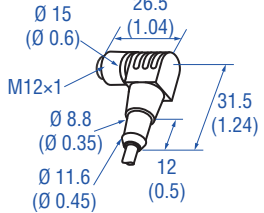
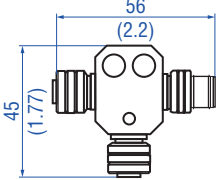
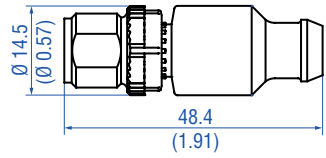
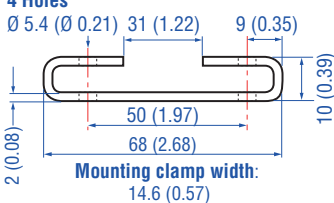
 <p>Ø 15 (Ø 0.6) 26.5 (1.04) M12x1 Ø 8.8 (Ø 0.35) Ø 11.6 (Ø 0.45) 31.5 (1.24) 12 (0.5)</p>	 <p>56 (2.2) 45 (1.77)</p>	 <p>Ø 14.5 (Ø 0.57) 48.4 (1.91)</p>	 <p>4 Holes Ø 5.4 (Ø 0.21) 31 (1.22) 9 (0.35) 2 (0.08) 50 (1.97) 68 (2.68) 10 (0.39) Mounting clamp width: 14.6 (0.57)</p>
<p>M12 (5 pin) female, angled Part no. 370 675</p> <p>Ingress protection: IP67 Cable: Shielded, pigtail end Cable length: 5 m (16.4 ft.)</p>	<p>M12 (5 pin) CANopen T-Connector Part no. 370 691</p> <p>Selfcuring coupling nut 2 × cable connector female 1 × cable connector male shielded</p>	<p>M12 (5 pin) CANopen bus terminator Part no. 370 700</p> <p>Housing: PUR Contact insert: Au</p>	<p>Mounting clamp Part no. 403 508</p> <p>Material: Stainless steel 1.4301/1.4305 (AISI 304/303)</p>

Rod end

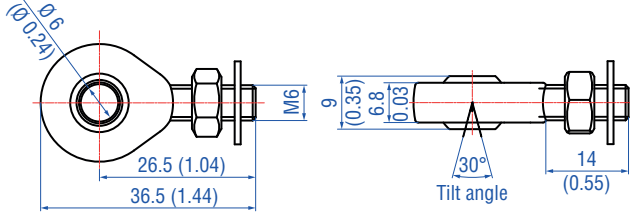
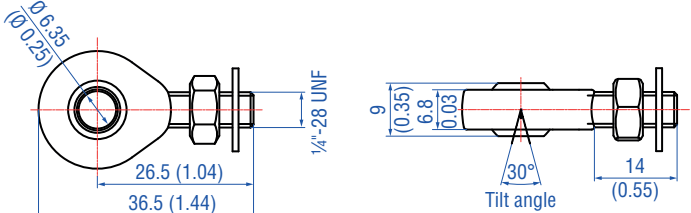
 <p>Ø 6 (Ø 0.24) M6 26.5 (1.04) 36.5 (1.44) 9 (0.35) 6.8 0.03 30° Tilt angle 14 (0.55)</p>	 <p>Ø 6.35 (Ø 0.25) 1/4"-28 UNF 26.5 (1.04) 36.5 (1.44) 9 (0.35) 6.8 0.03 30° Tilt angle 14 (0.55)</p>
<p>Rod end with M6 thread (for metric stroke length measurement) Part no. 254 210</p>	<p>Rod end with 1/4"-28 UNF thread (for US customary stroke length measurement) Part no. 254 235</p>

³ Follow the manufacturer's mounting instructions
Controlling design dimensions are in millimeters and measurements in () are in inches

ORDER CODE

1	2	3	4	5	6	7	8	9	10	11	12	13	14	15	16	17	18	19
E	R							D	3	4	1	C						1
a	b	c						d			e	f			g	h	i	

a	Sensor model
E R	Aluminum cylinder with a guided driving rod

b	Design
M	Inside thread M6 at end of rod (For metric stroke length measurement)
S	Inside thread 1/4"-28 UNF at end of rod (For US customary stroke length measurement)

c	Stroke length
X X X X M	0050...1500 mm
X X X X U	002.0...060.0 in.

Standard stroke length (mm)*

Stroke length	Ordering steps
50 ... 500 mm	25 mm
500...1500 mm	50 mm

Standard stroke length (in.)*

Stroke length	Ordering steps
2...22 in.	1.0 in.
22...60 in.	2.0 in.

d	Connection type
D 3 4	M12 (5 pin) male connector

e	Operating voltage
1	+24 VDC (-15 / +20 %)

f	Output
C 3 0 4	CANopen
C 4 0 4	CANopen (bus terminator)

g	Baud rate
1	1000 kBit/s
2	500 kBit/s
3	250 kBit/s
4	125 kBit/s

h	Resolution
4	10 µm
5	20 µm

i	Type
1	Standard

DELIVERY



Sensor

Accessories have to be ordered separately.

Select mounting accessories regarding your application:

- 1 or 2 rod ends M6 / 1/4"-28 UNF or / and
- 2 mounting clamps up to 1250 mm (50 in.) stroke length, 3 mounting clamps for 1500 mm (60 in.) stroke length

Manuals & Software available at:
www.mtssensors.com

* / Non standard stroke lengths are available; must be encoded in 5 mm / 0.1 in. increments

Document Part Number:
551341 Revision A (EN) 12/2016

Image reference:
Fig. 2: © Alterfalter - Fotolia.com

LOCATIONS

USA
MTS Systems Corporation
Sensors Division
3001 Sheldon Drive
Cary, N.C. 27513, USA
Tel. +1 919 677-0100
Fax +1 919 677-0200
info.us@mtssensors.com
www.mtssensors.com

JAPAN
MTS Sensors Technology Corp.
737 Aihara-machi,
Machida-shi,
Tokyo 194-0211, Japan
Tel. +81 42 775-3838
Fax +81 42 775-5512
info.jp@mtssensors.com
www.mtssensors.com

FRANCE
MTS Systems SAS
Zone EUROPARC Bâtiment EXA 16
16/18, rue Eugène Dupuis
94046 Creteil, France
Tel. +33 1 58 4390-28
Fax +33 1 58 4390-03
info.fr@mtssensors.com
www.mtssensors.com

GERMANY
MTS Sensor Technologie
GmbH & Co. KG
Auf dem Schüffel 9
58513 Lüdenscheid, Germany
Tel. +49 2351 9587-0
Fax +49 2351 56491
info.de@mtssensors.com
www.mtssensors.com

CHINA
MTS Sensors
Room 504, Huajing Commercial Center,
No. 188, North Qinzhou Road
200233 Shanghai, China
Tel. +86 21 6485 5800
Fax +86 21 6495 6329
info.cn@mtssensors.com
www.mtssensors.com

ITALY
MTS Systems Srl
Sensor Division
Via Camillo Golgi, 5/7
25064 Gussago (BS), Italy
Tel. +39 030 988 3819
Fax +39 030 982 3359
info.it@mtssensors.com
www.mtssensors.com

LEGAL NOTICES

MTS, Temposonics and Level Plus are registered trademarks of MTS Systems Corporation in the United States; MTS SENSORS and the MTS SENSORS logo are trademarks of MTS Systems Corporation within the United States. These trademarks may be protected in other countries. All other trademarks are the property of their respective owners. Copyright © 2016 MTS Systems Corporation. No license of any intellectual property rights is granted. MTS reserves the right to change the information within this document, change product designs, or withdraw products from availability for purchase without notice. Typographic and graphics errors or omissions are unintentional and subject to correction. Visit www.mtssensors.com for the latest product information.

