

EZ-SCREEN[®] LP Limited Function Safety Light Screen

Instruction Manual

Original Instructions
197310 Rev. B
17 February 2017
© Banner Engineering Corp. All rights reserved



197310

Contents

| | |
|---|----|
| 1 About This Document | 4 |
| 1.1 Important . . . Read This Before Proceeding! | 4 |
| 1.2 Use of Warnings and Cautions | 4 |
| 1.3 EU Declaration of Conformity (DoC) | 4 |
| 2 Introduction | 5 |
| 2.1 Features | 5 |
| 2.2 System Description | 5 |
| 2.2.1 Components | 6 |
| 2.2.2 How to Order | 6 |
| 2.3 Appropriate Applications and Limitations | 7 |
| 2.3.1 Appropriate Applications | 7 |
| 2.3.2 Examples: Inappropriate Applications | 8 |
| 2.4 Control Reliability: Redundancy and Self-Checking | 8 |
| 2.5 Operating Features | 8 |
| 3 Mechanical Installation | 10 |
| 3.1 Mechanical Installation Considerations | 10 |
| 3.2 Calculating the Safety Distance (Minimum Distance) | 10 |
| 3.2.1 Formula and Examples | 11 |
| 3.2.2 Examples | 12 |
| 3.3 Reducing or Eliminating Pass-Through Hazards | 12 |
| 3.4 Supplemental Safeguarding | 13 |
| 3.5 Other Considerations | 13 |
| 3.5.1 Adjacent Reflective Surfaces | 13 |
| 3.5.2 Use of Corner Mirrors | 14 |
| 3.5.3 Emitter and Receiver Orientation | 15 |
| 3.5.4 Installation of Multiple Systems | 16 |
| 3.6 Mounting System Components | 17 |
| 3.6.1 Mounting Hardware | 17 |
| 3.6.2 Sensor Mounting and Mechanical Alignment | 23 |
| 3.6.3 Mounting Dimensions and Defined Area | 24 |
| 4 Electrical Installation and Testing | 27 |
| 4.1 Routing Cordsets | 27 |
| 4.2 Initial Electrical Connections | 28 |
| 4.3 Initial Checkout Procedure | 28 |
| 4.3.1 Configuring the System for Initial Checkout | 28 |
| 4.3.2 Initial Power-Up | 28 |
| 4.3.3 Optical Alignment | 29 |
| 4.3.4 Optical Alignment Procedure with Mirrors | 30 |
| 4.3.5 Trip Test | 31 |
| 4.4 Electrical Connections to the Guarded Machine | 32 |
| 4.4.1 OSSD Output Connections | 32 |
| 4.4.2 FSD Interfacing Connections | 33 |
| 4.4.3 Machine Primary Control Elements | 34 |
| 4.4.4 Preparing for System Operation | 34 |
| 4.4.5 Sensor Interchangeability | 34 |
| 4.4.6 Commissioning Checkout | 35 |
| 4.5 Reference Wiring Diagrams | 36 |
| 4.5.1 Generic Emitter Wiring Diagram | 36 |
| 4.5.2 Generic Wiring—Self-checking Safety Module, Safety Controller, Safety PLC | 37 |
| 5 System Operation | 38 |
| 5.1 Security Protocol | 38 |
| 5.2 Status Indicators | 38 |
| 5.2.1 Emitter | 38 |
| 5.2.2 Receiver | 38 |
| 5.2.3 Receiver Status Indicator Operation - Trip Output | 38 |
| 5.3 Normal Operation | 39 |
| 5.3.1 System Power-Up | 39 |
| 5.3.2 Run Mode | 39 |
| 5.4 Periodic Checkout Requirements | 39 |
| 6 Troubleshooting and Maintenance | 40 |
| 6.1 Lockout Conditions | 40 |
| 6.2 Recovery Procedures | 40 |
| 6.2.1 Emitter Error Codes | 40 |

- 6.2.2 Receiver Error Codes 41
- 6.3 Electrical and Optical Noise 42
 - 6.3.1 Checking for Sources of Electrical Noise 43
 - 6.3.2 Checking for Sources of Optical Noise 43
- 6.4 Maintenance and Service 43
 - 6.4.1 Cleaning 43
 - 6.4.2 Replacement Parts 43
 - 6.4.3 Banner Engineering Corp Limited Warranty 43
 - 6.4.4 Warranty Service 44
 - 6.4.5 Manufacturing Date 44
 - 6.4.6 Disposal 44
- 7 Checkout Procedures 45
 - 7.1 Schedule of Checkouts 45
- 8 Specifications** 46
 - 8.1 Standard Emitter and Receiver Models—14 mm Resolution 46
 - 8.2 Standard Emitter and Receiver Models—25 mm Resolution 46
 - 8.3 General Specifications 47
 - 8.3.1 Emitter or Receiver Product Identification Label 47
 - 8.4 Emitter Specifications 47
 - 8.5 Receiver Specifications 48
- 9 Accessories 49
 - 9.1 Cordsets 49
 - 9.1.1 Connection Options 49
 - 9.1.2 RD to Flying Leads Cordsets 49
 - 9.1.3 Euro/M12 to Flying Leads Cordsets 49
 - 9.1.4 Splitter Cordsets 50
 - 9.1.5 Male M12/Euro to Female M12/Euro QD Cordsets 51
 - 9.1.6 DEE8-..D Adapter M12/Euro QD Cordsets 52
 - 9.1.7 Bulkhead Connector 52
 - 9.2 Interface Modules 52
 - 9.3 Contactors 53
 - 9.4 Muting Module 53
 - 9.5 Safety Controllers 53
 - 9.6 Snap-On Lens Shields 53
 - 9.7 EZ-LIGHT® for EZ-SCREEN® 54
 - 9.8 MSA Series Stands 54
 - 9.9 MSM Series Corner Mirrors 55
 - 9.10 SSM Series Corner Mirrors 55
 - 9.11 Accessory Mounting Bracket 56
 - 9.12 Alignment Aids 58
 - 9.13 Literature 58
- 10 Standards and **Regulations** 59
 - 10.1 Applicable U.S. Standards 59
 - 10.2 OSHA Regulations 59
 - 10.3 International/European Standards 59
 - 10.4 Contact Us 60
- 11 Glossary 61

1 About This Document

1.1 Important . . . Read This Before Proceeding!

It is the responsibility of the machine designer, controls engineer, machine builder, machine operator, and/or maintenance personnel or electrician to apply and maintain this device in full compliance with all applicable regulations and standards. The device can provide the required safeguarding function only if it is properly installed, properly operated, and properly maintained. This manual attempts to provide complete installation, operation, and maintenance instruction. *Reading the manual in its entirety is highly recommended.* Please direct any questions regarding the application or use of the device to Banner Engineering.

For more information regarding U.S. and international institutions that provide safeguarding application and safeguarding device performance standards, see [Standards and Regulations](#) on page 59.



WARNING: User Responsibility

The user is responsible to:

- Carefully read, understand, and comply with all instructions for this device.
- Perform a risk assessment that includes the specific machine guarding application. Guidance on a compliant methodology can be found in ISO 12100 or ANSI B11.0.
- Determine what safeguarding devices and methods are appropriate per the results of the risk assessment and implement per all applicable local, state, and national codes and regulations. See ISO 13849-1, ANSI B11.19, and/or other appropriate standards.
- Verify that the entire safeguarding system (including input devices, control systems, and output devices) is properly configured and installed, operational, and working as intended for the application.
- Periodically re-verify, as needed, that the entire safeguarding system is working as intended for the application.

Failure to follow any of these **responsibilities** may **potentially** create a dangerous **condition** that may lead to serious injury or death.

1.2 Use of Warnings and Cautions

The precautions and statements used throughout this document are indicated by alert symbols and must be followed for the safe use of the EZ-SCREEN LP Limited Function Safety Light Screen. Failure to follow all precautions and alerts may result in unsafe use or operation. The following signal words and alert symbols are defined as follows:

| Signal Word | Definition | Symbol |
|----------------|--|--------|
| WARNING | Warnings refer to potentially hazardous situations which, if not avoided, could result in death or serious injury. | |
| CAUTION | Cautions refer to potentially hazardous situations which, if not avoided, could result in minor or moderate injury. | |

These statements are intended to inform the machine designer and manufacturer, the end user, and maintenance personnel, how to avoid misapplication and effectively apply the EZ-SCREEN LP Limited Function Safety Light Screen to meet the various safeguarding application requirements. These individuals are responsible to read and abide by these statements.

1.3 EU Declaration of Conformity (DoC)

Banner Engineering Corp. herewith declares that the EZ-SCREEN LP Limited **Function** Safety Light Screen is in conformity with the provisions of the Machinery Directive 2006/42/EC and all essential health and safety requirements have been met.

Representative in EU: Peter Mertens, Managing Director Banner Engineering Europe. Address: Park Lane, Culliganlaan 2F, 1831 Diegem, Belgium.

2 Introduction

2.1 Features

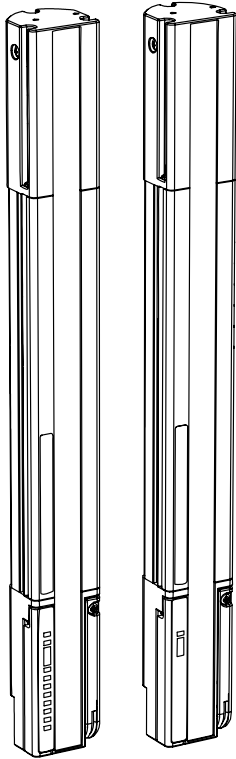

- A two-piece optoelectronic safeguarding device
- Creates a screen of synchronized, modulated infrared sensing beams that extend from end-to-end of the housing (no "dead" zone)
- Low-profile compact package for smaller production machines
- 14 mm or 25 mm resolutions
- Defined areas of 270 mm (10.6 in) or 550 mm (21.6 in)
- 100 mm to 4 m (4 in to 13 ft) sensing range
- Zone and Status indicators plus digital display to indicate number of beams blocked, detailed diagnostics
- FMEA tested to ensure control reliability
- Highly immune to EMI, RFI, ambient light, weld flash, and strobe light
- Safety PLC input compatible (per OSSD specifications)

2.2 System Description



Note: This manual refers to an emitter and its receiver, and their cabling, or a cascade of emitters and their receivers and their cabling as "a System".

Banner EZ-SCREEN LP emitters and receivers provide a redundant, microprocessor-controlled, opposed-mode optoelectronic "curtain of light", or "safety light screen". EZ-SCREEN LP typically is used for point-of-operation safeguarding, and is suited to safeguard a variety of machinery.

The EZ-SCREEN LP emitters have a row of synchronized modulated infrared (invisible) light-emitting diodes (LEDs) in a compact metal housing. Receivers have a corresponding row of synchronized photodetectors. The light screen created by the emitter and receiver is called the defined area; its width and height are determined by the length of the sensor pair and the distance between them. The low-profile housing provides maximum sensing within minimum space; its defined area (sensing area) is equivalent to the height of the housing. The maximum sensing range is 4 m (13 ft), which decreases if corner mirrors are used. The sensing area extends from end to end of the housing; there is no "dead zone." Specialty brackets allow easy mounting of cascaded sensors, without any loss of resolution between sensor pairs.

In typical operation, if any part of an operator's body (or any opaque object) of more than a pre-determined cross section is detected, the solid-state Output Signal Switching Device (OSSD) safety outputs turn OFF. These safety outputs are connected to the guarded machine's Final Switching Devices (FSDs) that control the machine primary control elements (MPCEs), which immediately stop the motion of the guarded machine.

Electrical connections (power, ground, inputs, and outputs) are made via M12 (Euro-style) quick-disconnects or unique RD (removable disconnect) cordsets, depending on model.

All models require a supply voltage of +24 V dc \pm 15%.

Both the emitter and the receiver feature 7-segment diagnostic displays and individual LEDs to provide continuous indication of operating status, configuration, and error conditions.

EZ-SCREEN LP is extensively FMEA (Failure Mode and Effects Analysis) tested to establish an extremely high degree of confidence that, when appropriately installed, no system component will (even if it should fail) cause a failure to danger.

2.2.1 Components

An EZ-SCREEN LP “System” refers to a compatible emitter and receiver (equal length and resolution; available separately or in pairs), and cordset(s) for each. It also refers to the emitters and receivers in a cascade, and their cabling. Mounting hardware is included with each emitter and receiver; special-purpose accessory brackets are also available, both for standalone pairs and for cascades.

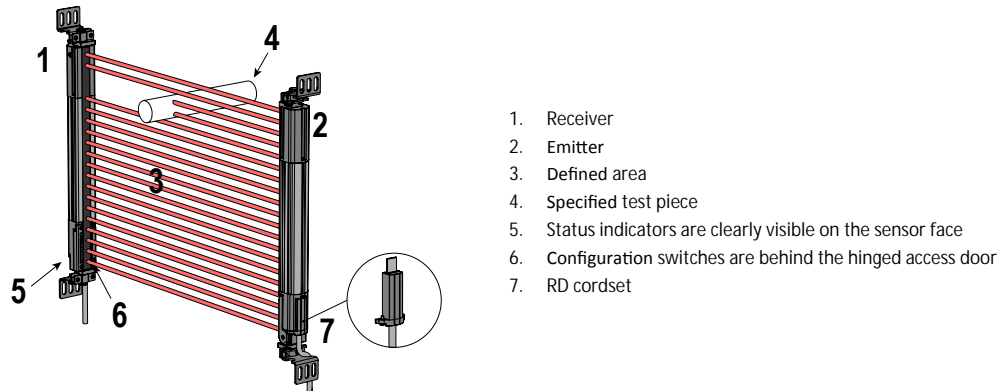

Figure 1. Banner EZ-SCREEN LP system: emitter, receiver, and two interconnecting cables

Models are listed with a factory installed 300 mm (1 ft) cable with 8-pin M12/Euro-style quick disconnect (QD) termination. The 13 mm (0.5 in) minimum bend radius for all cordset models accommodates low-clearance installations; cords can exit to left, right, or back of sensor, when mounting. The cabled QD option is useful to connect to splitter cables or other QD cordsets.



Cable pivots 180° as it exits the housing; bends to fit against perpendicular surfaces

Euro QD termination (pigtail); requires mating QD cordset for machine connection

Figure 2. EZ-SCREEN LP removable-disconnect (RD) cordsets

Standard models feature a yellow painted aluminum housing.

2.2.2 How to Order

1. Choose model, resolution (14 or 25 mm).
2. Choose an Emitter (E), a Receiver (R), or a Pair (P).
3. Choose the connection: 300 mm (12 in) cable with a 5-pin M12/Euro-Style QD or 300 mm (12 in) cable with a 8-pin M12/Euro-Style QD.
4. Choose one cordset for each sensor or two cordsets for a pair. See [Cordsets](#) on page 49.
 - M12/Euro Pigtail QD models for (example, SLPE..-270P8) require mating 8-pin M12/Euro QD cordsets, such as:
 - QDE cordset with flying leads
 - DEE2R double-ended cordset
 - CSB series splitter cordset

2.3 Appropriate Applications and Limitations



WARNING: Read this **Section** Carefully Before Installing the System

If all **mounting**, installation, interfacing, and checkout procedures are not followed properly, the Banner device cannot provide the protection for which it was designed. The user has the responsibility to ensure that all local, state, and national laws, rules, codes, or regulations relating to the installation and use of this control system in any particular application are satisfied. Ensure that all legal requirements have been met and that all technical installation and maintenance instructions contained in this manual are followed.

The user has the sole responsibility to ensure that this Banner device is installed and interfaced to the guarded machine by **Qualified Persons**¹, in accordance with this manual and applicable safety regulations.

The Banner EZ-SCREEN LP is intended for point-of-operation machine guarding and other safeguarding applications. It is the user's responsibility to verify whether the safeguarding is appropriate for the application and is installed, as instructed by this manual, by a Qualified Person.

The EZ-SCREEN LP ability to perform its safeguarding function depends upon the appropriateness of the application and upon its proper mechanical and electrical installation and interfacing to the guarded machine. If all **mounting**, **installation**, interfacing, and checkout procedures are not followed properly, the EZ-SCREEN LP cannot provide the **protection** for which it was designed.



CAUTION: Install System Only on Appropriate **Applications**

Banner EZ-SCREEN LP is for use only on machinery that can be stopped immediately after a stop signal is issued at any point in the machine's stroke or cycle, such as part-revolution clutched machines. Under no circumstances may the EZ-SCREEN LP be used on full-revolution clutched machinery or in unsuitable applications as those listed. If there is any doubt about whether or not your machinery is **compatible** with the EZ-SCREEN LP, contact Banner Engineering.

2.3.1 Appropriate Applications

EZ-SCREEN LP is typically used for, but is not limited to, the following applications:

- Small assembly equipment
- Automated production equipment
- Robotic work cells
- Molding presses
- Assembly and packaging machines
- Lean manufacturing systems

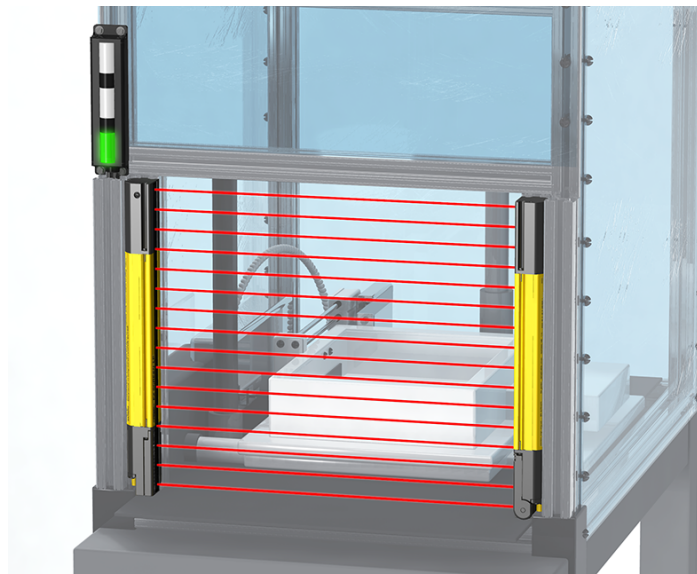

Figure 3. Typical Application

¹ A person who, by possession of a recognized degree or certificate of professional training, or who, by extensive knowledge, training and experience, has successfully demonstrated the ability to solve problems relating to the subject matter and work.

2.3.2 Examples: Inappropriate **Applications**

Do not use EZ-SCREEN LP in the following applications:

- With any machine that cannot be stopped immediately after a stop signal is issued, such as single-stroke (or full-revolution) clutched machinery
- With any machine with inadequate or inconsistent machine response time and stopping performance
- With any machine that ejects materials or component parts through the defined area
- In any environment that is likely to adversely affect photoelectric sensing efficiency. For example, corrosive chemicals or fluids or unusually severe levels of smoke or dust, if not controlled, may degrade sensing efficiency
- As a tripping device to initiate or reinitiate machine motion (PSDI applications), unless the machine and its control system fully comply with the relevant standard or regulation (see OSHA 29CFR1910.217, ANSI/NFPA 79, ANSI B11.19, ISO 12100, IEC 60204-1, IEC 61496-1, or other appropriate standard)

If an EZ-SCREEN LP is installed for use as a perimeter guard (where a pass-through hazard may exist, see [Reducing or Eliminating Pass-Through Hazards](#) on page 12), the dangerous machine motion can be initiated by normal means only after the safeguarded area is clear of individuals and the EZ-SCREEN LP has been manually reset.

2.4 Control Reliability: Redundancy and Self-Checking

Redundancy requires that EZ-SCREEN LP circuit components be backed up to the extent that, if the failure of a single component will prevent effective machine stopping action when needed, that component must have a redundant counterpart which will perform the same function. The EZ-SCREEN LP is designed with redundant microprocessors.

Redundancy must be maintained whenever the EZ-SCREEN LP is in operation. Because a redundant system is no longer redundant after a component has failed, EZ-SCREEN LP is designed to monitor itself continuously. A component failure detected by or within the self-checking system causes a stop signal to be sent to the guarded machine and puts the EZ-SCREEN LP into a Lockout condition.

A recovery from this type of Lockout condition requires:

- Replacement of the failed component (to restore redundancy)
- The appropriate reset procedure

The Diagnostic Display is used to diagnose causes of a Lockout condition. See [Troubleshooting and Maintenance](#) on page 40.

2.5 Operating Features

The sensing resolution is determined by the emitter and receiver model.



WARNING: Use of Trip/Latch Output

Application of power to the Banner device, the clearing of the defined area, or the reset of a Latch condition **MUST NOT** initiate dangerous machine motion. Machine control circuitry must be designed so that one or more initiation devices must be engaged (in a conscious act) to start the machine – in addition to the Banner device going into Run mode. Failure to follow these **instructions** may result in serious bodily injury or death.

Emitter Wiring Options— An EZ-SCREEN LP emitter can be connected either to its own power supply or to the receiver cable, color-for-color. The color-for-color wiring allows the emitter and receiver positions to be interchanged without rewiring.

Status Indicators—Status indicators on both the emitter and receiver are clearly visible on each sensor's front panel.

Emitter:

| Key | Description |
|-----|--|
| A | Status Indicator (Red/Green)—Shows whether power is applied or the device is in a lockout condition. |
| B | 7-segment Diagnostic Display—indicates specific error or configuration conditions. |

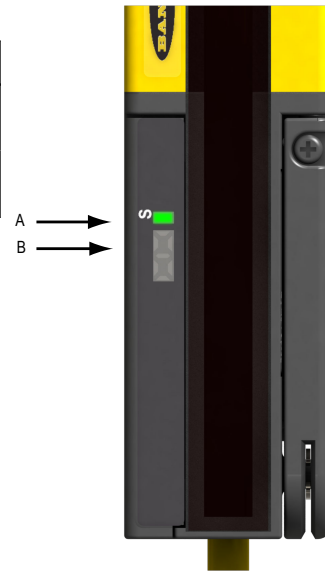

Figure 4. Emitter

Receiver:

1-Digit Diagnostic Display—indicates specific error, configuration conditions, or total number of blocked beams.

| Key | Description |
|-----|--|
| A | Reset indicator (Yellow)—shows System status: <ul style="list-style-type: none"> Run mode (ON) |
| B | Status indicator (Red/Green)—shows System status: <ul style="list-style-type: none"> Reduced Resolution enabled (flashing green) Outputs are ON or OFF (green ON or red ON) The System is in Lockout condition (flashing red) |
| C | 7-Segment Diagnostic Display |
| D | Zone indicators (Red/Green)—each shows status of approximately 1/8 of the total beams: <ul style="list-style-type: none"> Aligned and clear (green ON) Blocked and/or misaligned (red ON) |
| E | Zone 1 Indicator—indicates beam synchronization status |

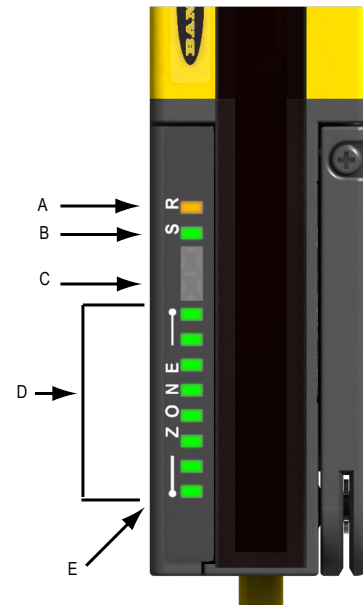

Figure 5. Receiver

3 Mechanical Installation

The EZ-SCREEN LP system performance as a safety guarding device depends on:

- The suitability of the application
- The proper mechanical and electrical installation and interfacing to the guarded machine



WARNING: Read this **Section** Carefully Before Installing the System

If all mounting, installation, interfacing, and checkout procedures are not followed properly, the Banner device cannot provide the protection for which it was designed. The user has the responsibility to ensure that all local, state, and national laws, rules, codes, or regulations relating to the installation and use of this control system in any particular application are satisfied. Ensure that all legal requirements have been met and that all technical installation and maintenance instructions contained in this manual are followed.

The user has the sole responsibility to ensure that this Banner device is installed and interfaced to the guarded machine by Qualified Persons², in accordance with this manual and applicable safety regulations.

3.1 Mechanical Installation Considerations

The two primary factors that influence the layout of the EZ-SCREEN LP system mechanical installation are the Safety Distance (Minimum Distance) (see [Calculating the Safety Distance \(Minimum Distance\)](#) on page 10) and the supplemental safeguarding/eliminating pass-through hazards (see [Reducing or Eliminating Pass-Through Hazards](#) on page 12). Other considerations include:

- Emitter and Receiver Orientation
- Adjacent Reflective Surfaces
- Use of Corner Mirrors
- Installation of Multiple Systems



WARNING: Position Components Carefully

The **emitter** and receiver must be **positioned** such that the hazard cannot be accessed by reaching over, under, around, or through the sensing **field**. Additional and supplemental guarding may be required.

3.2 Calculating the Safety Distance (Minimum Distance)

Safety Distance (Ds), also called Minimum Distance (S), is the minimum distance required between the defined area and the closest reachable hazard point. The distance is calculated so that when an object or a person is detected (by blocking a sensing beam), the EZ-SCREEN LP sends a stop signal to the machine, causing it to stop by the time the object or person can reach any machine hazard point.

The distance is calculated differently for U.S. and European installations. Both methods take into account several factors, including a calculated human speed, the total system stopping time (which itself has several components), and the depth penetration factor. After the distance has been determined, record the calculated distance on the Daily Checkout Card.



WARNING: Safety Distance (Minimum Distance)

The Banner emitters and receivers must be mounted at a distance from the nearest hazard such that an individual cannot reach the hazard before cessation of the hazardous motion or situation. This distance can be calculated using the formulas in this section, as described by ANSI B11.19 and ISO 13855, and must be greater than 100 mm (4 in) regardless of calculated value. Failure to establish and maintain the safety distance (minimum distance) may result in serious bodily injury or death.

Reduced Resolutions increases Dpf (or C). Increase the depth **penetration** factor to calculate proper minimum distance whenever Reduced **Resolution** is used. Always turn Reduced Resolution Off when the larger minimum object detection size is not required.

² A person who, by possession of a recognized degree or certificate of professional training, or who, by extensive knowledge, training and experience, has successfully demonstrated the ability to solve problems relating to the subject matter and work.

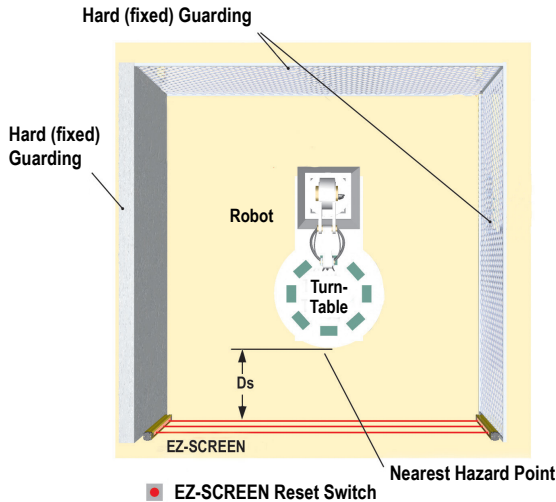

Figure 6. Safety distance (minimum distance) and hard (fixed) guarding

3.2.1 Formula and Examples

| U.S. Applications | European Applications |
|--|---|
| The Safety (Separation) Distance formula for U.S. applications: | The Minimum Distance formula for European applications: |
| $D_s = K \times (T_s + T_r) + D_{pf}$ | $S = (K \times T) + C$ |
| Ds the Safety Distance, in inches | S the Minimum Distance, in mm, from danger zone to light screen center line; minimum allowable distance is 100 mm (175 mm for non-industrial applications), regardless of calculated value |
| K 1600 mm per second (or 63 in per second), the OSHA 29CFR1910.217, and ANSI B11.19 recommended hand-speed constant (see Note 1 below) | K hand-speed constant (see Note 2 below); 2000 mm/s (for Minimum Distances ≤ 500 mm) 1600 mm/s (for Minimum Distances > 500 mm) |
| Ts the overall stop time of the machine (in seconds) from the initial stop signal to the final ceasing of all motion, including stop times of all relevant control elements (for example, IM-T-. Interface Modules) and measured at maximum machine velocity (see Note 3 below) | T the overall machine stopping response time (in seconds), from the physical initiation of the safety device and the machine coming to a stop (or the hazard removed). This can be broken down into two parts: Ts and Tr where T = Ts + Tr |
| Tr the maximum response time, in seconds, of the EZ-SCREEN LP emitter/ receiver pair (depending on model) | C the additional distance, in mm, based on intrusion of a hand or object towards the danger zone prior to actuation of a safety device. Calculate using the formula (in mm): |
| Dpf the added distance due to the depth penetration factor as prescribed in OSHA 29CFR1910.217, and ANSI B11.19 for U.S. applications. See Depth Penetration Factor (Dpf) table below or calculate using the formula (in mm): $D_{pf} = 3.4 \times (S - 7)$ where S is the resolution of the light curtain (for S ≤ 63 mm). | $C = 8 \times (d - 14)$ |
| | where d is the resolution of the light curtain (for d ≤ 40 mm), or use 850 mm for C. |

Table 1: Depth Penetration Factor (Dpf)

| Depth Penetration Factor (Dpf) | |
|--------------------------------|----------------|
| 14 mm Systems | 25 mm Systems |
| 24 mm (0.94 in) | 61 mm (2.4 in) |

Notes:

1. The OSHA-recommended hand speed constant K has been determined by various studies and, although these studies indicate speeds of 1600 mm/sec. (63 in./sec.) to more than 2500 mm/sec. (100 in./sec.), they are not conclusive determinations. Consider all factors, including the physical ability of the operator, when determining the value of K to be used.
2. The recommended hand speed constant K, derived from data on approach speeds of the body or parts of the body as stated in ISO 13855.
3. Ts is usually measured by a stop-time measuring device. If the machine manufacturer's specified stop time is used, at least 20% should be added to allow for possible clutch/ brake system deterioration. This measurement must take into account the slower of the two MPCE channels, and the response time of all devices or controls that react to stop the machine.



WARNING: Determine Correct Stop Time

Stop **time** (Ts) must include the response **time** of all devices or controls that react to stop the machine. If all devices are not included, the calculated safety distance (Ds or S) will be too short. This can lead to serious bodily injury or death. Be sure to include the stop time of all relevant devices and controls in your calculations.

If required, each of the two Machine Primary Control Elements (MPCE1 and MPCE2) must be capable of immediately stopping the dangerous machine motion, regardless of the state of the other. These two channels of machine control need not be identical, but the stop time performance of the machine (Ts, used to calculate the safety distance) must take into account the slower of the two channels.

3.2.2 Examples

Example: U.S. Applications, Model

| | | |
|-----|---|---|
| K | = | 63 in. per second (the hand speed constant set by OSHA) |
| Ts | = | 0.32 (0.250 second is specified by the machine manufacturer; plus 20% safety factor; plus 20 ms for interface module IM-T-9A response time) |
| Tr | = | 0.0105 seconds (the specified response time of an SLPP14-270 EZ-SCREEN LP) |
| Dpf | = | 0.94 in (14 mm resolution) |

Substitute the numbers into the formula as follows:

$$D_s = K \times (T_s + T_r) + D_{pf}$$

Mount the EZ-SCREEN LP emitter and receiver so that no part of the defined area will be closer than 21.8 inches to the closest reachable hazard point on the guarded machine.

Example: European Applications, Model

| | | |
|---|---|--|
| K | = | 1600 mm per second |
| T | = | 0.33 (0.250 second specified by machine manufacturer; plus 20% safety factor; plus 20 ms interface module response time), plus 0.0105 seconds (the specified SLPP14-270 response time) |
| C | = | $8 \times (14 - 14) = 0$ mm (14 mm resolution) |

Substitute the numbers into the formula as follows:

$$S = (K \times T) + C$$

Mount the EZ-SCREEN LP emitter and receiver so that no part of the defined area will be closer than 528 mm to the closest reachable hazard point on the guarded machine.

3.3 Reducing or **Eliminating** Pass-Through Hazards

A *pass-through* hazard is associated with applications where personnel may pass through a safeguard (which issues a stop command to remove the hazard), and then continues into the guarded area, such as in perimeter guarding. Subsequently, their presence is no longer detected, and the related danger becomes the unexpected start or restart of the machine while personnel are within the guarded area.

In the use of light screens, a pass-through hazard typically results from large safety distances calculated from long stopping times, large minimum object sensitivities, reach-over, reach-through, or other installation considerations. A pass-through hazard can be generated with as little as 75 mm (3 in) between the defined area and the machine frame or hard (fixed) guarding.

Eliminate or reduce pass-through hazards whenever possible. While it is recommended to eliminate the pass-through hazard altogether, this may not be possible due to machine layout, machine capabilities, or other application considerations.

One solution is to ensure that personnel are continually sensed while within the hazardous area. This can be accomplished by using supplemental safeguarding, such as described by the safety requirements in ANSI B11.19 or other appropriate standards.

An alternative method is to ensure that once the safeguarding device is tripped it will latch and will require a deliberate manual action to reset. This method of safeguarding relies upon the location of the reset switch as well as safe work practices and procedures to prevent an unexpected start or restart of the guarded machine.



WARNING: Use of the Banner device for Perimeter Guarding

If a Banner device is installed in an application that results in a pass-through hazard (for example, perimeter guarding), either the Banner device System or the Machine Primary Control Elements (MPCEs) of the guarded machine must cause a Latched response following an interruption of the defined area.

The reset of this Latched condition may only be achieved by actuating a reset switch that is separate from the normal means of machine cycle initiation.

Lockout/Tagout procedures per ANSI Z244.1 may be required, or additional safeguarding, as described by ANSI B11.19 safety requirements or other appropriate standards, must be used if a passthrough hazard cannot be eliminated or reduced to an acceptable level of risk. Failure to observe this warning may result in serious bodily injury or death.

3.4 Supplemental Safeguarding

As described in [Calculating the Safety Distance \(Minimum Distance\)](#) on page 10, the EZ-SCREEN LP must be properly positioned such that an individual cannot reach through the defined area and access the hazard point before the machine has stopped.

Additionally, the hazard cannot be accessible by reaching around, under, or over the defined area. To accomplish this, supplemental guarding (mechanical barriers, such as screens or bars), as described by ANSI B11.19 safety requirements or other appropriate standards, must be installed. Access will then be possible only through the defined area of the EZ-SCREEN LP System or through other safeguarding that prevents access to the hazard (see [Figure 7](#) on page 13).

The mechanical barriers used for this purpose are typically called "hard (fixed) guarding"; there must be no gaps between the hard (fixed) guarding and the defined area. Any openings in the hard (fixed) guarding must comply with the safe opening requirements of ANSI B11.19 or other appropriate standard.

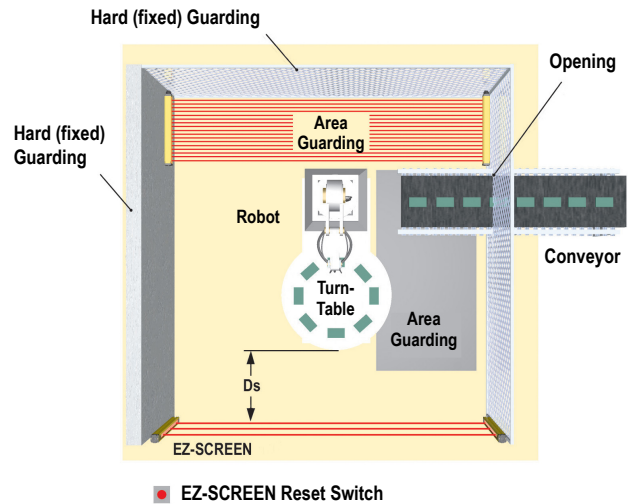

Figure 7. An example of supplemental safeguarding

[Figure 7](#) on page 13 shows an example of supplemental safeguarding inside a robotic work cell. The EZ-SCREEN LP, in conjunction with the hard (fixed) guarding, is the primary safeguard. Supplemental safeguarding (such as a horizontal-mounted safety light screen as an area guard) is required in areas that cannot be viewed from the reset switch (for example, behind the robot and the conveyor). Additional supplemental safeguarding may be required to prevent clearance or trapping hazards (for example, a safety mat as an area guard between the robot, the turntable, and the conveyor).



WARNING: The Hazard Must Be Accessible Only through the **Defined Area**

The installation of the EZ-SCREEN LP must prevent any individual from reaching around, under, over or through the defined area and into the hazard without being detected. Mechanical barriers (for example, hard (fixed) guarding) or supplemental safeguarding may be required to comply with this requirement, and is described by ANSI B11.19 safety requirements or other appropriate standards.

3.5 Other Considerations

3.5.1 Adjacent Reflective Surfaces



WARNING: Avoid **Installation** Near **Reflective** Surfaces

Avoid locating the defined area near a reflective surface; it could reflect sensing beam(s) around an object or person within the defined area, and prevent its detection by the EZ-SCREEN LP. Perform the trip test, as described in the manual, to detect such reflection(s) and the resultant optical short circuit. Failure to prevent **reflection** problems will result in incomplete guarding and could result in serious injury or death.

A reflective surface located adjacent to the defined area may deflect one or more beams around an object in the defined area. In the worst case, an optical short circuit may occur, allowing an object to pass undetected through the defined area.

This reflective surface may result from shiny surfaces or glossy paint on the machine, the workpiece, the work surface, the floor, or the walls. Beams deflected by reflective surfaces are discovered by performing the trip test and the periodic checkout procedures. To eliminate problem reflections:

- If possible, relocate the sensors to move the beams away from the reflective surface(s), being careful to maintain adequate separation distance
- Otherwise, if possible, paint, mask, or roughen the shiny surface to reduce its reflectivity
- Where these are not possible (as with a shiny workpiece or machine frame), determine the worst-case resolution resulting from the optical short circuit and use the corresponding depth penetration factor (Dpf or C) in the Safety Distance (Minimum Distance) formula; or mount the sensors in such a way that the receiver's field of view and/or the emitter's spread of light are restricted from the reflective surface
- Repeat the trip test (see *Trip Test* under *Initial Checkout Procedure* on page 28) to verify these changes have eliminated the problem reflection(s). If the workpiece is especially reflective and comes close to the defined area, perform the trip test with the workpiece in place

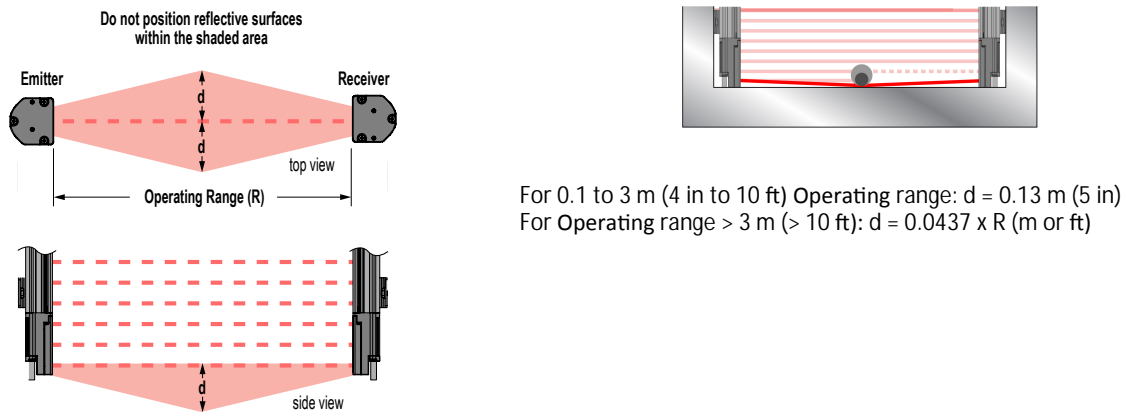

Figure 8. Adjacent Reflective Surfaces

At the midpoint of the defined area, a test piece (represented by the darker circle in *Figure 8* on page 14) with the specified system resolution does not cause a blocked condition due to an optical short circuit. Green Zone indicator lights are On and the OSSDs are On. Increasing the size of the test piece to block additional beams causes a blocked condition. The size of the test piece required to do this determines the actual resolution. Use the table below to calculate Dpf or Factor "C" when a shiny surface causes an optical short circuit.

| Test Piece Model | Resolution | Depth Penetration Factor for U.S. Applications | Factor "C" for European Applications |
|------------------|------------|--|--------------------------------------|
| STP-13 | 14 mm | 24 mm (1 in) | 0 mm |
| STP-2 | 19 mm | 41 mm (1.6 in) | 40 mm (1.6 in) |
| STP-16 | 25 mm | 61 mm (2.5 in) | 88 mm (3.5 in) |
| STP-14 | 30 mm | 78 mm (3 in) | 128 mm (5 in) |
| STP-4 | 32 mm | 85 mm (3.3 in) | 144 mm (5.7 in) |
| STP-17 | 34 mm | 92 mm (3.6 in) | 160 mm (6.3 in) |
| STP-1 | 38 mm | 106 mm (4.2 in) | 192 mm (7.6 in) |
| STP-3 | 45 mm | 129 mm (5 in) | 850 mm (33.5 in) |
| STP-8 | 51 mm | 150 mm (5.9 in) | 850 mm (33.5 in) |
| STP-5 | 58 mm | 173 mm (6.8 in) | 850 mm (33.5 in) |
| STP-15 | 60 mm | 180 mm (7 in) | 850 mm (33.5 in) |
| STP-12 | 62 mm | 187 mm (7.4 in) | 850 mm (33.5 in) |

3.5.2 Use of Corner Mirrors

EZ-SCREEN LP may be used with one or more corner mirrors. Mirrors are not allowed for applications that would allow undetected personnel access into the safeguarded area. The use of glass-surface corner mirrors reduces the maximum specified emitter/receiver separation by approximately 8 percent per mirror, as follows:

Table 2: SSM and MSM Series Glass-Surface Mirrors³—Maximum Emitter and Receiver Separation

| Number of Corner Mirrors | Max. Emitter / Receiver Separation | Sensor Models |
|--------------------------|------------------------------------|---|
| 1 | 3.7 m (12.1 ft) | 14 mm or 25 mm Resolution Models with 4 m (13 ft) Range |
| 2 | 3.4 m (11.2 ft) | |
| 3 | 3.1 m (10.3 ft) | |
| 4 | 2.8 m (9.2 ft) | |

If mirrors are used, the difference between the angle of incidence from the emitter to the mirror and from the mirror to the receiver must be between 45° and 120°. If placed at a sharper angle, an object in the light screen may deflect beam(s) to the receiver, preventing the object from being detected, also known as false proxing. Angles greater than 120° result in difficult alignment and possible optical short circuits.



WARNING: Avoid Retroreflective Installation

Do not install emitters and receivers in "retroreflective" mode, with less than a 45° angle of incidence, as shown. Sensing may be unreliable in this **configuration** and result in a serious bodily injury or death.

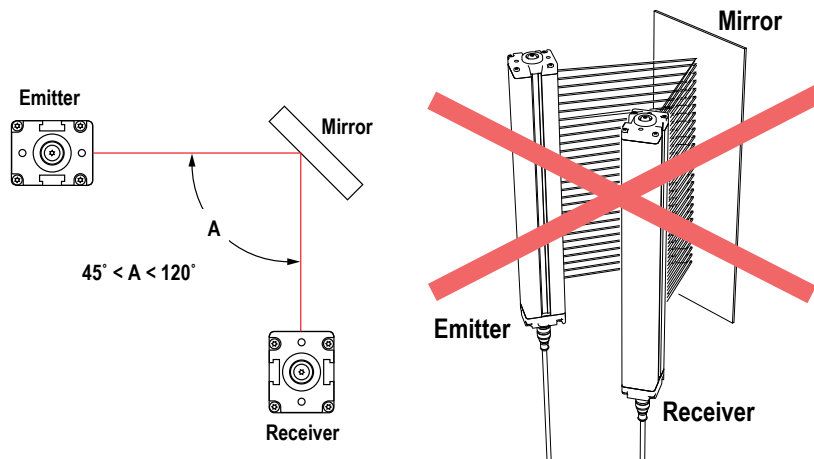

Figure 9. Using EZ-SCREEN LP sensors in a retroreflective mode

3.5.3 Emitter and Receiver Orientation

The emitter and receiver must be mounted parallel to each other and aligned in a common plane, with both machine interface cable ends pointing in the same direction. Never mount the emitter with its machine interface cable end oriented in the opposite direction of the cable end of the receiver. If this occurs, voids in the light screen may allow objects or personnel to pass through the defined area undetected.

The emitter and receiver may be oriented in a vertical or horizontal plane, or at any angle between horizontal and vertical, as long as they are parallel to each other and their cable ends point in the same direction. Verify that the light screen completely covers all access to the hazard point that is not already protected by hard (fixed) guarding or other supplemental guarding.



WARNING: Proper Orientation of System Emitters and Receivers

EZ-SCREEN LP emitters and receivers must be installed with their corresponding cabled ends pointing in the same direction (for example, both cabled ends facing up). Failure to orient them properly will impair the performance of the EZ-SCREEN LP System and will result in incomplete guarding, and could result in serious bodily injury or death.

³ See the specific mirror data sheet or www.bannerengineering.com for more information.

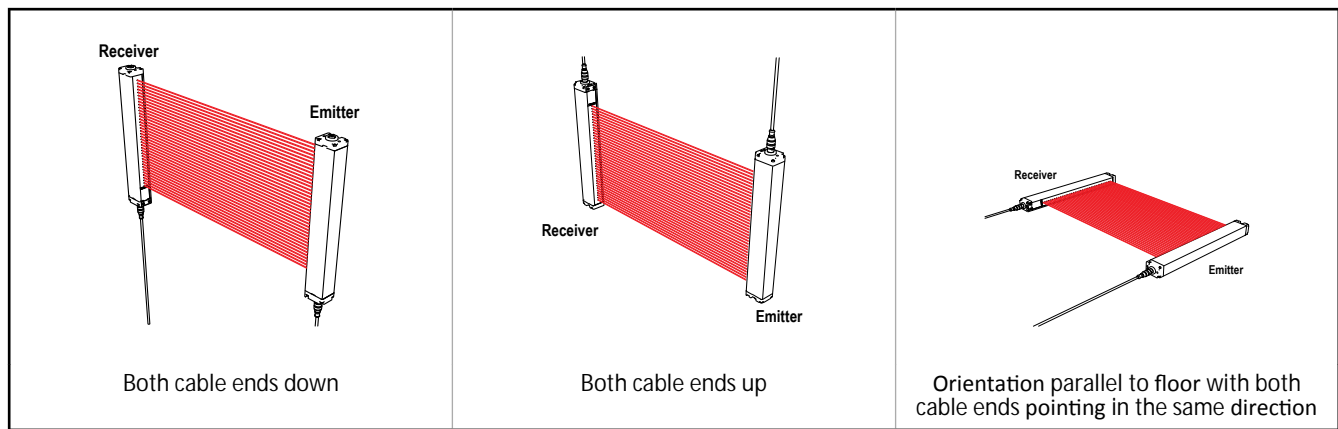

Figure 10. Examples of Correct Emitter/Receiver Orientation

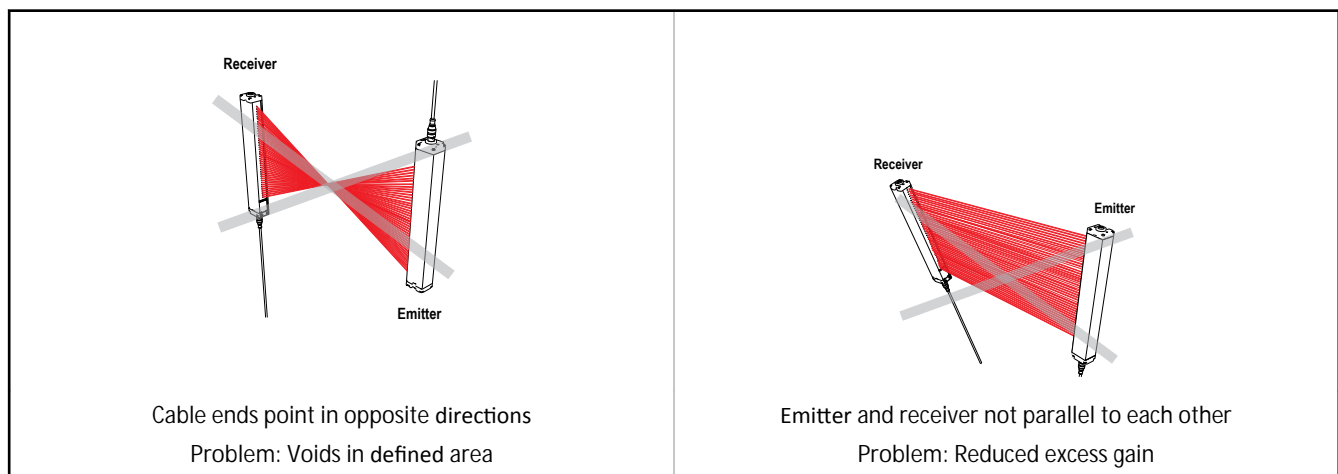

Figure 11. Examples of Incorrect Emitter/Receiver Orientation

3.5.4 Installation of Multiple Systems

Whenever two or more EZ-SCREEN LP emitter and receiver pairs are adjacent to one another, optical crosstalk may take place between the systems. To minimize optical crosstalk, alternate the positions of the emitters and receivers.

When three or more systems are installed in the same plane, optical crosstalk may occur between sensor pairs whose emitter and receiver lenses are oriented in the same direction. In this situation, eliminate optical crosstalk by mounting these sensor pairs exactly in line with each other within one plane, or by adding a mechanical barrier between the pairs.

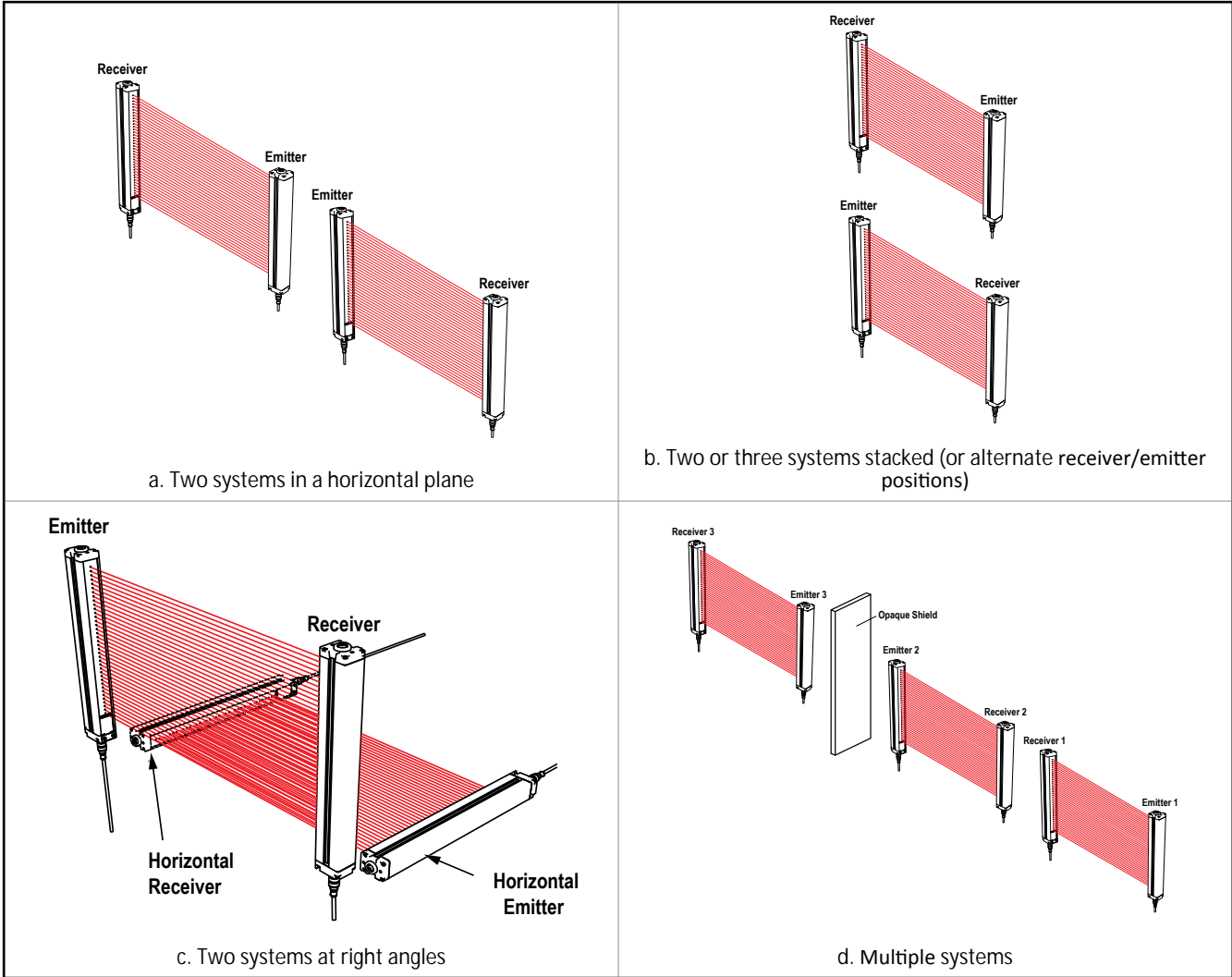

Figure 12. Installation of Multiple Systems



WARNING: Multiple Pairs of Sensors
Do not connect multiple pairs of sensors to one Interface Module (for example, IM-T-9A/-11A) or otherwise parallel OSSD outputs. **Connection of multiple OSSD safety outputs to a single device may result in serious bodily injury or death, and is prohibited.**

3.6 Mounting System Components

3.6.1 Mounting Hardware

Emitter/receiver pairs can be spaced from 0.1 m (4 in) to 4 m (13 ft) apart. This distance is reduced if corner mirrors are used. Each sensor is shipped with two end-cap brackets and at least two side-mount brackets. The supplied end-cap brackets allow 360° rotation. Side-mount brackets allow 30° rotation in one direction, and 10° in the other. Sidemount brackets may be mounted on either or both sides of the housing. If additional rotation is required, see the available accessory brackets.

Mounting the Optional LPA-MBK-10 End-Mount Brackets

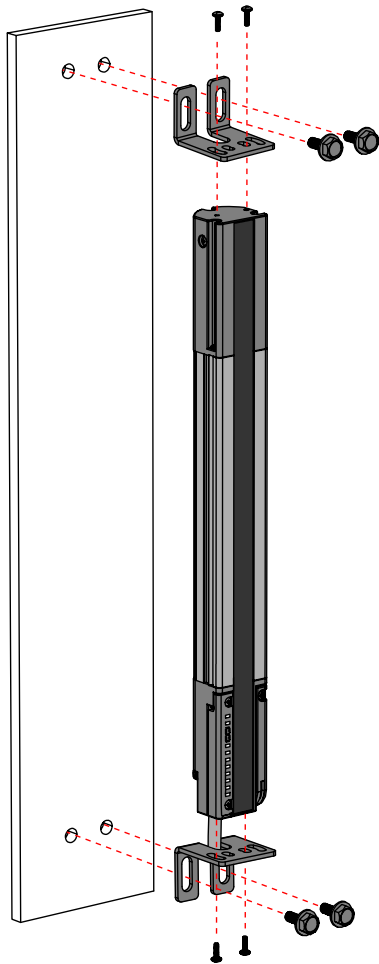

Figure 13. End-Mount Brackets

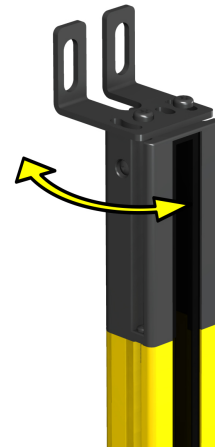

Figure 14. 360° Rotation

- Two brackets are supplied with the accessory kit.
- Brackets are designed to mount directly to MSA Series stands using the hardware supplied with the stands.
- See [Accessory Mounting Bracket](#) on page 56 for mounting bracket dimensions.



Important: The connector ends of both sensors must point in the same direction (see [Figure 10](#) on page 16). Loosely mount the brackets to the desired surface using the supplied M5 bolts and nuts, or user-supplied hardware. Brackets may face in or out, as desired.

1. From a common point of reference (ensuring the calculated minimum safety distance), measure to position the emitter and receiver in the same plane, with their midpoints directly opposite each other.
2. Attach the end-cap bracket plate to each end of the sensor, using the supplied M3 × 6 screws.
3. Position the emitter and receiver in their brackets, as shown in [Figure 10](#) on page 16. Loosely attach the front bracket plate to the bracket, at each end.
4. Verify that the sensor windows directly face each other. Measure from a reference plane, for example, a level building floor, to the same point(s) on the emitter and receiver to verify their mechanical alignment. Use a carpenter's level, a plumb bob, or the optional LAT-1 Laser Alignment Tool (see [Alignment Aids](#) on page 58) or check the diagonal distances between the sensors, to achieve mechanical alignment. Final alignment procedures are explained in [Initial Checkout Procedure](#) on page 28.
5. Tighten all fasteners.

Mounting the Optional LPA-MBK-11 End-Mount Brackets

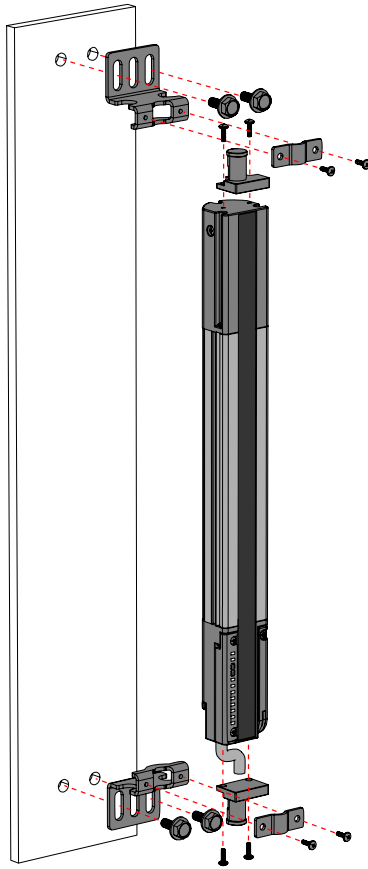

Figure 15. Optional End-Mount Brackets

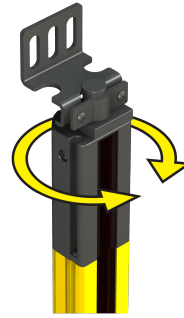

Figure 16. 360° Rotation

- Two brackets are supplied with the accessory kit.
- Brackets are designed to mount directly to MSA Series stands using the hardware supplied with the stands.
- See [Accessory Mounting Bracket](#) on page 56 for mounting bracket dimensions.



Important: The connector ends of both sensors must point in the same direction (see [Figure 10](#) on page 16). Loosely mount the brackets to the desired surface using the supplied M5 bolts and nuts, or user-supplied hardware. Brackets may face in or out, as desired.

1. From a common point of reference (ensuring the calculated minimum safety distance), measure to position the emitter and receiver in the same plane, with their midpoints directly opposite each other.
2. Attach the end-cap bracket plate to each end of the sensor, using the supplied M3x6 screws.
3. Position the emitter and receiver in their brackets, as shown in [Figure 10](#) on page 16. Loosely attach the front bracket plate to the bracket, at each end.
4. Verify that the sensor windows directly face each other. Measure from a reference plane, for example, a level building floor, to the same point(s) on the emitter and receiver to verify their mechanical alignment. Use a carpenter's level, a plumb bob, or the optional LAT-1 Laser Alignment Tool (see [Alignment Aids](#) on page 58) or check the diagonal distances between the sensors, to achieve mechanical alignment. Final alignment procedures are explained in [Initial Checkout Procedure](#) on page 28.
5. Tighten all fasteners.

Mounting the Optional LPA-MBK-12 Side-Mount Brackets

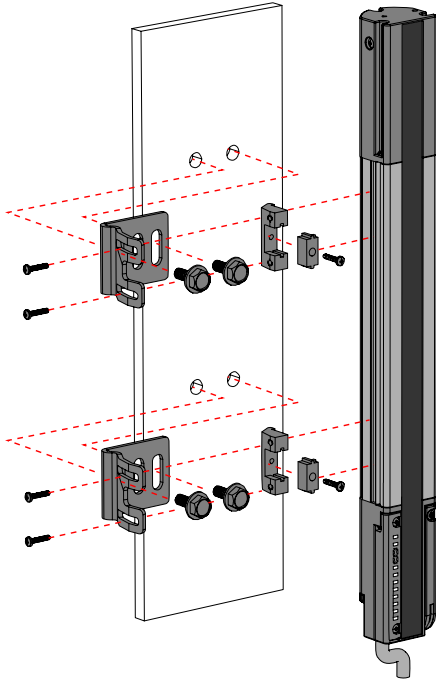

Figure 17. Side-Mount Brackets

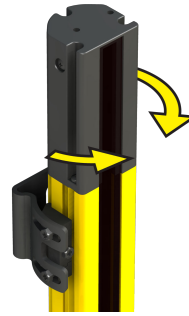

Figure 18. 360° Rotation

1. From a common point of reference (ensuring the calculated minimum safety distance), measure to locate the emitter and receiver in the same plane, with their midpoints directly opposite each other.



Important: The connector ends of both sensors must point in the same direction (see [Figure 10](#) on page 16).

2. Mount the emitter and receiver mounting brackets to the desired surface, using the supplied M5 bolts and nuts or user-supplied hardware.
3. Attach the 2-piece clamp to the sensor housing side channels (either side of the housing) at the appropriate locations, using the supplied M3x6 screws.
4. Attach the clamp to the bracket, using the supplied M5 screws.
5. Position the emitter and receiver windows directly facing each other. Measure from a reference plane, for example, a level building floor, to the same point(s) on the emitter and receiver to verify their mechanical alignment. Use a carpenter's level, a plumb bob, or the optional LAT-1 Laser Alignment Tool (see [Alignment Aids](#) on page 58) or check the diagonal distances between the sensors, to achieve mechanical alignment. Final alignment procedures are explained in [Initial Checkout Procedure](#) on page 28.
6. Tighten all fasteners.

Bracket Assembly Instructions

Final assembly (tightening) of the mounting bracket should be accomplished with a #1 Phillips screwdriver or 3/16 in. / 5 mm "thin-walled" nut driver to achieve the listed torque specifications. Sensors may be mounted with side-mount brackets, end-mount brackets, or a combination of both.

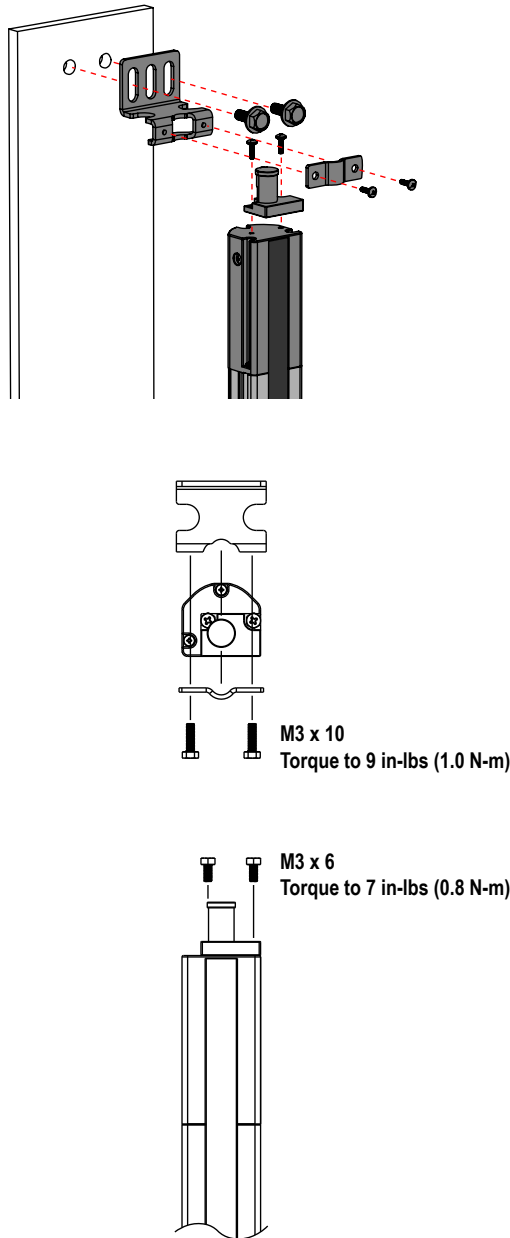

Figure 19. LPA-MBK-11 End-mount hardware attachment

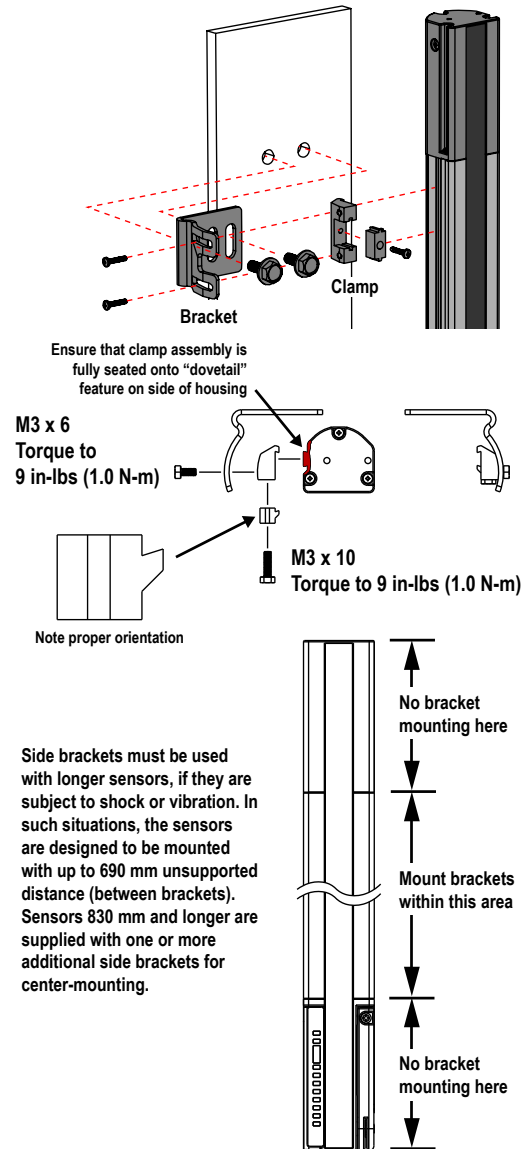
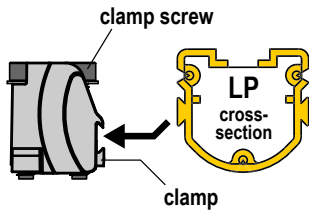

Figure 20. LPA-MBK-12 Side-mount hardware attachment

Installing and Mounting the Optional LPA-MBK-16 Side-Mount Bracket

Use the screwdriver provided with the EZ-SCREEN LP to access the DIP switches. Use a 3 mm hex driver to tighten the mounting bracket and achieve the listed torque specifications.

- 1 Adjust clamp screw to loosen or tighten clamp.



- 2 Slide inner bracket assembly into outer bracket groove.

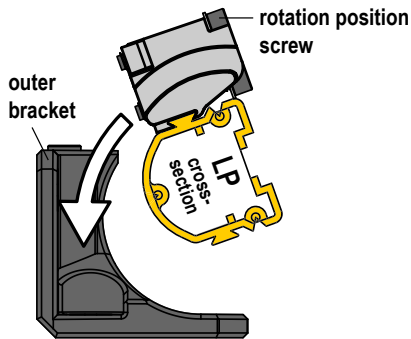

(Recommended: mount outer bracket to wall before Step 2 process)

- 3 With the light screen aligned, tighten rotation position screw to complete installation.

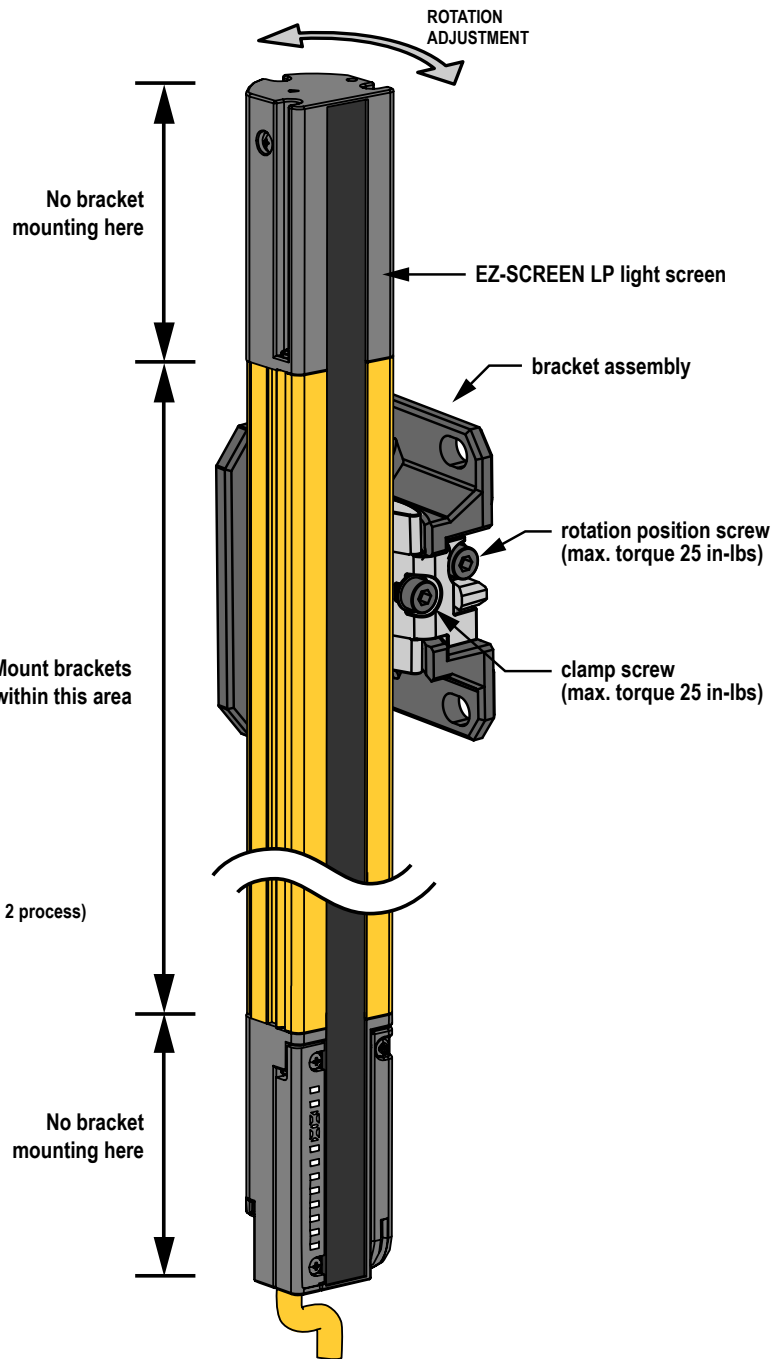
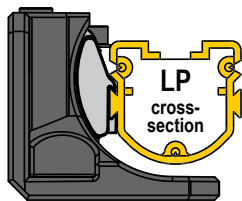

To mount the EZ-SCREEN LP:

1. Position the emitter and receiver windows directly facing each other.
2. Measure from a reference plane, for example, a level building floor, to the same point(s) on the emitter and receiver to verify their mechanical alignment. Use a carpenter's level, a plumb bob, or the optional LAT-1 Laser Alignment Tool (see [Alignment Aids](#) on page 58) or check the diagonal distances between the sensors, to achieve mechanical alignment. Final alignment procedures are explained in [Initial Checkout Procedure](#) on page 28.
3. Tighten all fasteners.

3.6.2 Sensor **M**ounting and Mechanical Alignment

Verify that:

- The emitter and receiver are directly opposite each other
- Nothing is interrupting the defined area
- The defined area is the same distance from a common reference plane for each sensor
- The emitter and receiver are in the same plane and are level/plumb and square to each other (vertical, horizontal, or inclined at the same angle, and not tilted front-to-back or side-to-side)

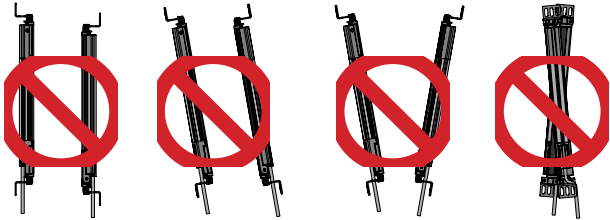
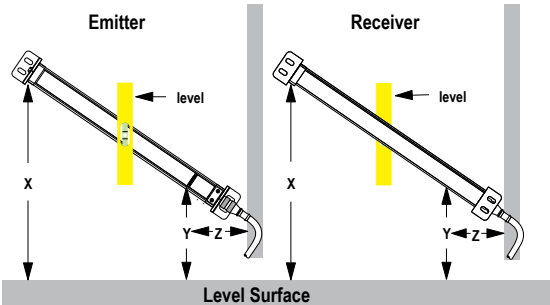
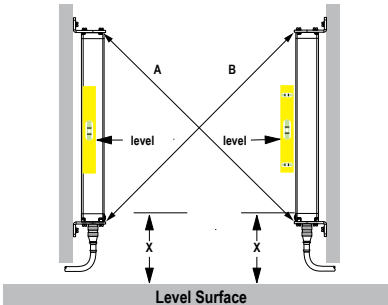

Figure 21. Incorrect Sensor Alignment



Angled or Horizontal **I**nstallations – verify that:

- Distance X at the emitter and receiver are equal
- Distance Y at the emitter and receiver are equal
- Distance Z at the emitter and receiver are equal from parallel surfaces
- Vertical face (the window) is level/plumb
- Defined area is square. Check diagonal measurements if possible; see Vertical Installations, on the right.



Vertical **I**nstallations – verify that:

- Distance X at the emitter and receiver are equal
- Both sensors are level/plumb (check both the side and face)
- Defined area is square. Check diagonal measurements if possible (Diagonal A = Diagonal B).

3.6.3 Mounting Dimensions and Defined Area

All measurements are listed in millimeters [inches], unless noted otherwise.

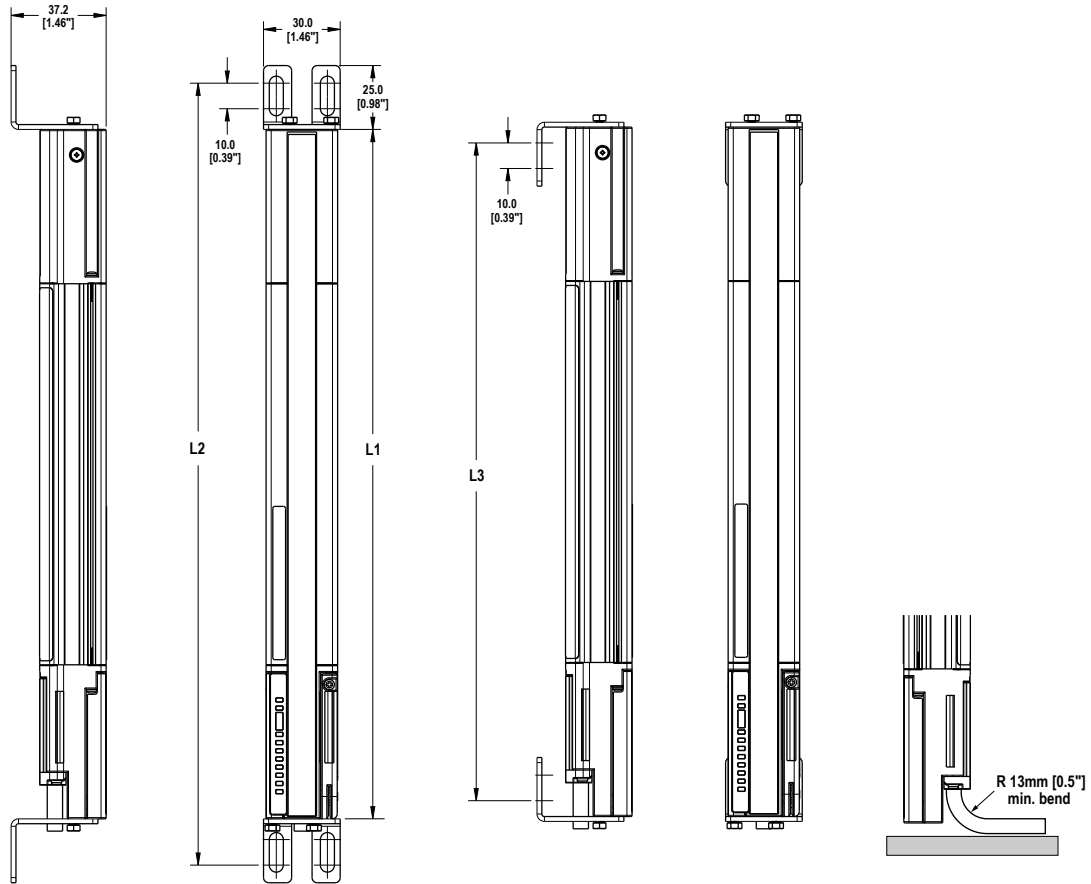

| Emitter / Receiver Model | Housing Length | | Distance Between Bracket Holes | | Defined Area ⁴ |
|--------------------------|------------------|------------------|--------------------------------|--------|---------------------------|
| | L1 | L2 | L3 | L3 | |
| SLPE...270.. | 270 mm (10.6 in) | 326 mm (12.8 in) | 258 mm (10.2 in) | 270 mm | |
| SLPE...550.. | 549 mm (21.6 in) | 605 mm (23.8 in) | 537 mm (21.1 in) | 550 mm | |

Figure 22. Emitter and receiver mounting dimensions and defined area

⁴ Nominal measurement

Optional End-Cap Brackets
LPA-MBK-10

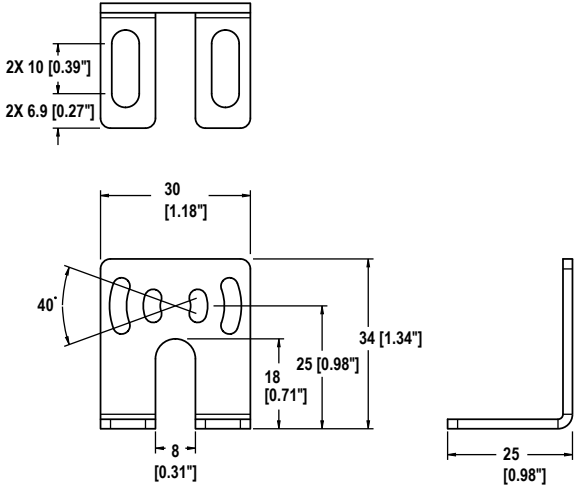

Optional End-Cap Brackets
LPA-MBK-11

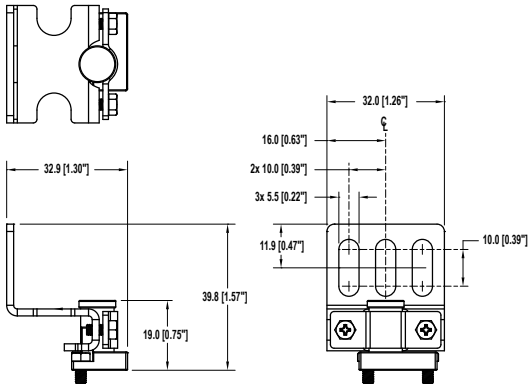
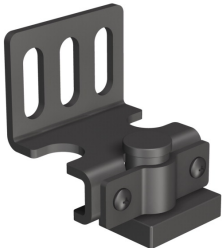

Optional Side-Mount Bracket
LPA-MBK-12

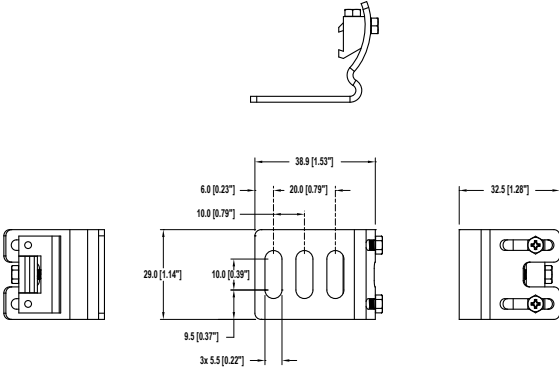
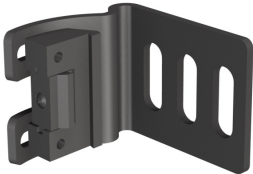

Figure 23. Included mounting bracket—dimensions (for emitter or receiver)

Optional Side-Mount Bracket
LPA-MBK-16

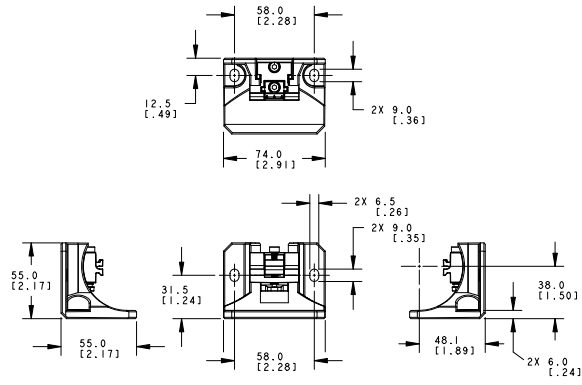
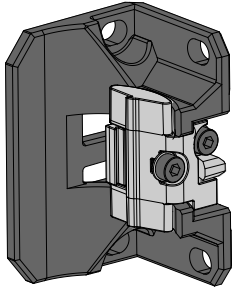

Figure 24. Optional mounting bracket—dimensions (for emitter or receiver)

4 Electrical Installation and Testing

The following are the main steps to electrically install the EZ-SCREEN LP components and interface with the guarded machine.



WARNING: Read this **Section** Carefully Before Installing the System

If all mounting, installation, interfacing, and checkout procedures are not followed properly, the Banner device cannot provide the protection for which it was designed. The user has the responsibility to ensure that all local, state, and national laws, rules, codes, or regulations relating to the installation and use of this control system in any particular application are satisfied. Ensure that all legal requirements have been met and that all technical installation and maintenance instructions contained in this manual are followed.

The user has the sole responsibility to ensure that this Banner device is installed and interfaced to the guarded machine by Qualified Persons⁵, in accordance with this manual and applicable safety regulations.

1. Routing cordsets and making initial electrical connections (see [Routing Cordsets](#) on page 27 and [Initial Electrical Connections](#) on page 28).
2. Apply power to each emitter/receiver pair (see [Initial Electrical Connections](#) on page 28).
3. Perform an Initial Checkout Procedure (see [Initial Checkout Procedure](#) on page 28).
4. Make all electrical interface connections to the guarded machine (see [Electrical Connections to the Guarded Machine](#) on page 32).
5. Perform a commissioning checkout procedure (see [Commissioning Checkout](#) on page 35).

4.1 Routing Cordsets

Attach the required cordsets to the sensors, and route the sensor cables to the junction box, electrical panel, or other enclosure in which the interface module, the redundant mechanically linked interposing relays, FSDs, or other safety-related parts of the control system are located. This must be done per local wiring code for low-voltage dc control cables and may require installation of electrical conduit. See [Cordsets](#) on page 49 for selection of Banner supplied cables.



Note: The machine interface cable must connect to the sensor end adjacent to the indicators, in order for the System to operate properly.

EZ-SCREEN LP is designed and manufactured to be highly resistant to electrical noise and to operate reliably in industrial settings. However, extreme electrical noise may cause a random Trip or Latch condition; in extreme cases, a Lockout is possible.

Emitter and receiver wiring is low voltage; routing the sensor wires alongside power wires, motor/servo wires, or other high voltage wiring may inject noise into the EZ-SCREEN LP System. It is good wiring practice, and sometimes may be required by code, to isolate emitter and receiver cables from high-voltage wires, avoid routing cables close to “noisy” wiring, and provide a good connection to earth ground.

Sensor cabling and any interconnect wiring should have an insulation temperature rating of at least 90 °C (194 °F).

For SLP..... sensors:

1. Slide the RD connector firmly into the housing's RD port.
2. Tighten the Phillips screws at the base of the connector to lock into place.

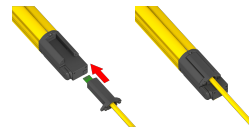

Table 3: Maximum machine interface cable length versus total load current (OSSDs + Aux)

| Maximum Machine Interface Cordset Length ⁶ | | | | | |
|---|-----------------|-----------------|-----------------|-----------------|----------------|
| Total Load Current (OSSD 1 + OSSD 2 + Aux Out) | | | | | |
| 0.1 A | 0.25 A | 0.5 A | 0.75 A | 1.0 A | 1.25 A |
| 78.9 m (259 ft) | 62.5 m (205 ft) | 46.6 m (153 ft) | 37.2 m (122 ft) | 30.8 m (101 ft) | 26.5 m (87 ft) |



Note: Emitter and receiver power (current) requirements are accounted for. The above values represent additional current draw that must be accounted for.

⁵ A person who, by possession of a recognized degree or certificate of professional training, or who, by extensive knowledge, training and experience, has successfully demonstrated the ability to solve problems relating to the subject matter and work.

⁶ RDLP-8..D or QDE-8..D model cordsets; may require multiple cables.



Note: Maximum cordset lengths are intended to ensure that adequate power is available to the EZ-SCREEN LP when the supply is operating at +20 V dc. Values in the previous table are worst case. Contact Banner Engineering if there are any questions.

4.2 Initial Electrical Connections



WARNING: Proper Electrical Hookup

Electrical hookup must be made by **Qualified Personnel** and must comply with NEC (National Electrical Code) and local standards. Make no more **connections** to the EZ-SCREEN LP System than are described in this manual. **Connection** of other wiring or equipment to the EZ-SCREEN LP System could result in serious bodily injury or death.

Lockout/tagout procedures may be required (refer to OSHA1910.147, ANSI Z244-1, ISO 14118, or the appropriate standard for controlling hazardous energy). Following relevant electrical standards and wiring codes, such as the NEC, NFPA79 or IEC60204-1, always connect the earth ground (green/yellow wire). Do not operate the EZ-SCREEN LP without an earth ground **connection**.

Make the electrical connections in the order described in this section. Do not remove end-caps; no internal connections are to be made. All connections are made through the RD or pigtail QD connections.

Emitter Cordset

EZ-SCREEN LP emitters have an 8-pin cordset, but not all conductors are used. The other wires are in place to allow a parallel connection (color-for-color) to the receiver cable, providing sensor interchangeability (or “swapability”); either sensor may be installed at either cordset connection. In addition to providing similar cabling, this wiring scheme is advantageous during installation, wiring, and troubleshooting.

Receiver Cordset

Do not connect any wires to the machine control circuits (OSSD outputs) at this **time**.

4.3 Initial Checkout Procedure

The initial checkout procedure must be performed by a **Qualified Person**. It must be performed only after configuring the System and after connecting the emitter and receiver.

The procedure is performed on two occasions:

- To ensure proper installation when the System is first installed
- To ensure proper System function whenever any maintenance or modification is performed on the System or on the machinery that is guarded by the System.

4.3.1 Configuring the System for Initial Checkout

For the initial checkout, the EZ-SCREEN LP System must be checked without power available to the guarded machine. Final interface connections to the guarded machine cannot take place until the light screen system has been checked out. This may require lockout/tagout procedures (refer to OSHA1910.147, ANSI Z244-1, ISO 14118, or the appropriate standard for controlling hazardous energy). The OSSD connections will be made after the initial checkout procedure has been successfully completed.

Verify that:

- Power has been removed from (or is not available to) the guarded machine and its controls or actuators
- The machine control circuit or the Safety/Interface Module is not connected to the OSSD outputs at this time (permanent connections will be made later)

4.3.2 Initial Power-Up

1. Inspect the area near the light screen for reflective surfaces, including work pieces and the guarded machine. Reflective surfaces may cause light beams to reflect around a person in the light screen, preventing the person from being detected and not stopping the machine motion (see [Adjacent Reflective Surfaces](#) on page 13).
2. Eliminate the reflective surfaces as much as possible by relocating, painting, masking, or roughening them. Remaining problem reflections will become apparent during the trip test.
3. Verify that power is removed from the EZ-SCREEN LP System and from the guarded machine and that the OSSD safety outputs are not connected.
4. Remove all obstructions from the light screen.
5. Leaving power to the guarded machine off, make power and earth ground connections on both the emitter and receiver cables (see [Reference Wiring Diagrams](#) on page 36).
6. Power up the EZ-SCREEN LP System only.
7. Verify that the input power is present to both the emitter and the receiver. At least one indicator on both the emitter and the receiver should be On and the start-up sequence should cycle.

8. Watch both the emitter and the receiver Status indicators, 7-segment displays, and the receiver Zone indicators to determine the light screen alignment status.
 - Lockout **Condition**—the emitter Status indicator is single-flashing Red; the receiver Status indicator is On Red, and the 7-segment display reads CH1. Proceed to [Troubleshooting and Maintenance](#) on page 40 for diagnostic information.
 - Receiver Lockout **Condition** —the receiver Status indicator is single-flashing Red, with Zone and Reset indicators Off. Proceed to [Troubleshooting and Maintenance](#) on page 40 for diagnostic information.
 - Normal **Operating Mode** (emitter)—The Status indicator is On Green.
 - Clear (Run) **Condition** (receiver)—The Status indicator is On Green (or flashing Green if reduced resolution is enabled), and the Reset indicator is On Yellow. All Zone indicators are On Green.
 - A Blocked **Condition** (receiver)—The Status indicator is On Red, the yellow Reset indicator is On, one or more Zone indicator(s) are On Red, identifying the location of the blocked beams, and the number of blocked beams is displayed. Proceed to [Optical Alignment](#) on page 29.



Note: If beam 1 is blocked, Zone indicator 1 is Red and all others are Off. Beam 1 provides the synchronization signal.

See [Operating Features](#) on page 8 for indicator and display information.

4.3.3 Optical Alignment



CAUTION: Ensure that no individuals are exposed to any hazard if the OSSD outputs turn ON when the emitter and receiver become aligned.

Verify the sensor mounting.

Verify the optimal alignment, adjusting the sensor rotation with the power On:

1. Verify that the emitter and the receiver are pointed squarely at each other. Use a straight edge (for example, a level) to determine the direction the sensor is facing. The sensor face must be perpendicular to the optical axis.

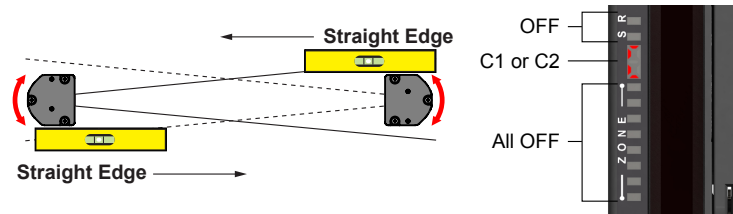

2. If the Channel #1 beam is not aligned, the Status and Zone 1 indicators are Red, the Reset indicator is yellow, and the 7-segment display sequentially indicates CH1. Zone indicators 2–8 are Off.

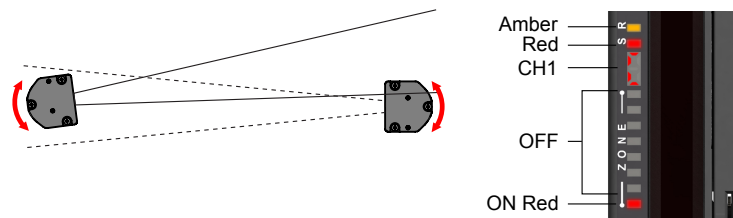

3. If the Green Status and Yellow Reset indicators are On, go to the next step. If not, rotate each sensor (one at a time) left and right until the Green Status indicator is On. (As the sensor rotates out of alignment, the Red Status indicator turns On). As more beams are aligned, the Zone indicators turn from Red to Green and the number of blocked beam indicators decreases.



Note: If the emitter Test input is open, the Diagnostic Display will indicate the total number of beams in the system (minus one) and all Zone indicators will be Red (except for 14-beam systems, where Zone 1 indicator is Green).

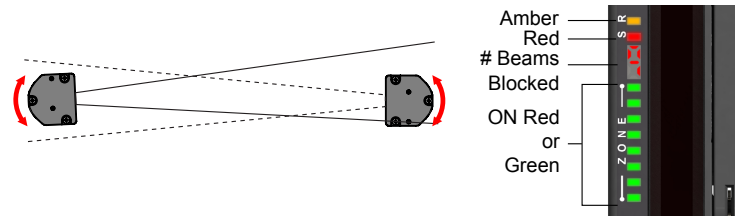

4. Optimize alignment and maximize excess gain.
 - a. Slightly loosen the sensor mounting screws.
 - b. Rotate one sensor left and right, noting the positions in each arc where the Status indicators turn Red (Blocked condition); repeat with the other sensor.
 - c. Center each sensor between those two positions.
 - d. Tighten the mounting screws, making sure to maintain the positioning as the screws are tightened.

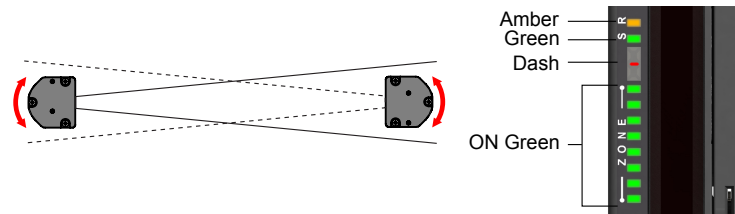

For situations where alignment is difficult, a LAT-1-LP Laser Alignment Tool can be used to assist or confirm alignment by providing a visible red dot along the sensor's optical axis.



Note: If at any time the Red Status indicator begins to flash steadily, the System has entered a Lockout condition. See [Troubleshooting and Maintenance](#) on page 40 for further information.

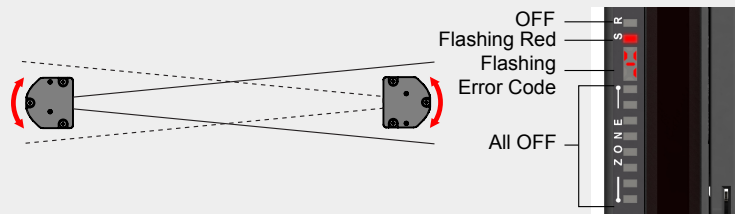

4.3.4 Optical Alignment Procedure with Mirrors

EZ-SCREEN LP sensors may be used with one or more corner mirrors for guarding more than one side of an area. The MSM-... and SSM-... rear-surface glass mirrors are rated at 85% efficiency. Thus, excess gain and sensing range are reduced when using mirrors; see Use of Corner Mirrors, under [Other Considerations](#) on page 13.

During any adjustments, allow only one individual to adjust any one item at any one time.

In addition to the standard optical alignment procedure, verify:

1. The emitter, receiver, and all mirrors are level and plumb.
2. The middle of the defined area and the center point of the mirrors are approximately the same distance from a common reference point, such as the same height above a level floor.
3. There are equal amounts of mirror surface above and below the defined area such that the optical beams are not passing below or above the mirror.



Note: A LAT-1-LP Laser Alignment Tool is very helpful by providing a visible red dot along the optical axis. See [Figure 25](#) on page 31 and Banner Safety Applications Note SA104 (p/n [57477](#)) for further information.

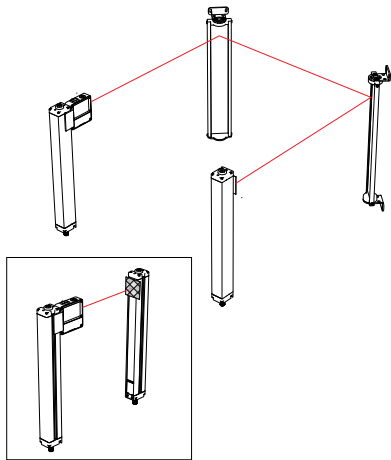

Figure 25. Optical alignment using the LAT-1-LP

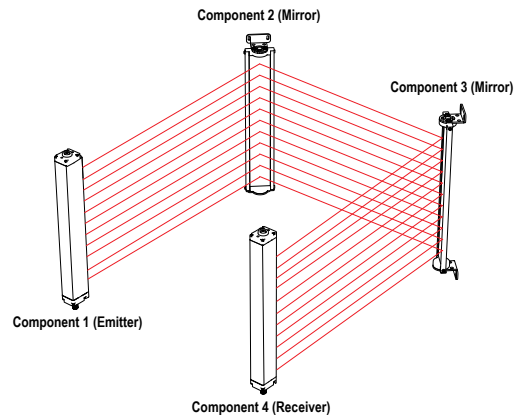

Figure 26. Corner Mirror Alignment

4.3.5 Trip Test

After optimizing the optical alignment and configuring fixed blanking and/or reduced resolution (if applicable), perform the trip test to verify the detection capability of the EZ-SCREEN LP System. This test also verifies correct sensor orientation, identifies optical short circuits, and verifies the expected resolution for applications using reduced resolution. After the installation has passed the trip test, the safety outputs may be connected and the commissioning checkout may be performed (initial installations only).



Note: Cascaded systems—To test a cascaded system, test each light screen individually, while monitoring the status indicator on the first (master) receiver in the cascade.

1. Select the proper test piece, supplied with the receiver.

Table 4: Appropriate Test Pieces for Trip Test

| 14 mm Resolution Models | 25 mm Resolution Models |
|-----------------------------------|-----------------------------------|
| 14 mm (0.55 in) dia. Model STP-13 | 25 mm (0.98 in) dia. Model STP-16 |

2. Verify that the System is in Run mode, the Green Status indicator is On (or flashing if reduced resolution is enabled), all Zone indicators are green, and the amber Status indicator is On. A manual reset may be required in Latch mode.
3. Pass the specified test piece through the defined area in three paths: near the emitter, near the receiver, and midway between the emitter and receiver.

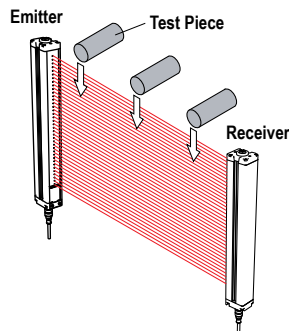

Figure 27. Trip Test

4. During each pass, while the test piece is interrupting the defined area, at least one Zone indicator must be Red. The Red Zone indicator must change with the **position** of the test piece within the **defined** area.
 - Trip Output Operation: The Status indicator must turn red and remain red for as long as the test piece remains in the defined area. If not, the installation has failed the trip test.

If all Zone indicators turn green or fail to follow the position of the test piece while it is within the defined area, the installation has failed the trip test. Check for correct sensor orientation, reflective surfaces, and unguarded areas created due to the use of Blanking. Do not continue until the situation is corrected.

When the test piece is removed from the defined area, in trip output operation, the green Status indicator must turn on (or flash green, if reduced resolution is enabled). In latch output operation, the Status indicator will remain red until a manual reset is performed (the amber Reset indicator will be flashing).



WARNING: If Trip Test Indicates a Problem

If the EZ-SCREEN LP System does not respond properly to the trip test, do not attempt to use the System. If this occurs, the System cannot be relied on to stop dangerous machine motion when a person or object enters the defined area. Serious bodily injury or death could result.

- If mirrors are used in the application: Test the defined area on each leg of the sensing path (for example, emitter to mirror, between mirror and receiver).

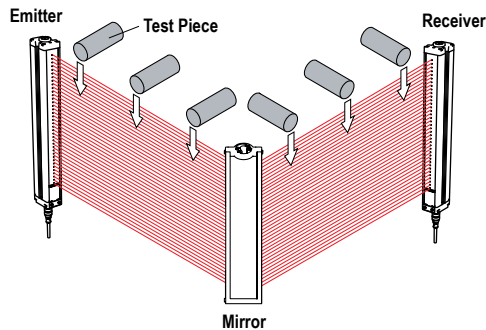

Figure 28. Trip Test with Corner Mirror

- If the EZ-SCREEN LP System passes all checks during the trip test, go on to [Electrical Connections to the Guarded Machine](#) on page 32.

4.4 Electrical Connections to the Guarded Machine

Verify that power has been removed from the EZ-SCREEN LP and the guarded machine. Make the permanent electrical connections as described in [OSSD Output Connections](#) on page 32 and [FSD Interfacing Connections](#) on page 33 as required by each individual application.

Lockout/tagout procedures may be required (refer to OSHA 1910.147, ANSI Z244-1, ISO 14118, or the appropriate standard for controlling hazardous energy). Follow relevant electrical standards and wiring codes, such as the NEC, NFPA79 or IEC 60204-1.

Supply power and external device monitoring (EDM) should already be connected. The EZ-SCREEN LP must also have been aligned and passed the Initial Checkout, as described in [Initial Checkout Procedure](#) on page 28.

The final connections to be made or verified are:

- OSSD outputs
- FSD interfacing



CAUTION: Shock Hazard

Always disconnect power from the Banner device and the guarded machine before making any connections or replacing any component. Use extreme **caution** to avoid electrical shock at all **times**.

4.4.1 OSSD Output Connections

Both the Output Signal Switching Device (OSSD) outputs must be connected to the machine control so that the machine's safety-related control system interrupts the circuit or power to the Machine Primary Control Element(s) (MPCE), resulting in a non-hazardous condition.

Final Switching Devices (FSDs) typically accomplish this when the OSSDs go to an OFF state.

Refer to the output specifications in the Receiver Specifications (see [Specifications](#) on page 46) and the warning below before making OSSD output connections and interfacing the EZ-SCREEN LP to the machine.

**WARNING: Interfacing of Both OSSDs**

Both OSSD (Output Signal Switching Device) outputs must be connected to the machine control so that the machine's safety-related control system interrupts the circuit to the machine primary control element(s), resulting in a non-hazardous condition.

Never wire an intermediate device(s) (for example, PLC, PES, or PC) that can fail in such a manner that there is the loss of the safety stop command, OR in such a manner that the safety function can be suspended, overridden, or defeated, unless accomplished with the same or greater degree of safety.

**WARNING: OSSD Interfacing**

To ensure proper operation, the Banner device output parameters and machine input parameters must be considered when interfacing the Banner device OSSD outputs to machine inputs. Machine control circuitry must be designed so that the maximum load resistance value is not exceeded and that the maximum specified OSSD Off-state voltage does not result in an On condition.

Failure to properly interface the OSSD Outputs to the guarded machine may result in serious bodily injury or death.

4.4.2 FSD Interfacing **Connections**

FSDs (Final Switching Devices) take many forms. The most common are forced-guided devices, mechanically linked relays, or interface modules. The mechanical linkage between the contacts allows the device to be monitored by the External Device Monitoring circuit for certain failures.

Depending on the application, the use of FSDs can facilitate controlling voltage and current that differs from the OSSD outputs of the EZ-SCREEN LP. FSDs can also be used to control an additional number of hazards by creating multiple safety stop circuits.

Protective Stop (Safety Stop) Circuits

A protective stop (safety stop) allows for an orderly cessation of motion for safeguarding purposes, which results in a stop of motion and removal of power from the MPCEs (assuming this does not create additional hazards). A protective stop circuit typically comprises a minimum of two normally open contacts from forced-guided, mechanically linked relays, which are monitored through External Device Monitoring to detect certain failures in order to prevent the loss of the safety function. Such a circuit can be described as a "safe switching point". Typically, protective stop circuits are either single-channel, which is a series connection of at least two normally open contacts; or dual-channel, which is a separate connection of two normally open contacts. In either method, the safety function relies on the use of redundant contacts to control a single hazard. If one contact fails On, the second contact arrests the hazards and prevents the next cycle from occurring.

The interfacing of the protective stop circuits must be accomplished so that the safety function cannot be suspended, overridden, or defeated, unless accomplished in a manner of the same or greater degree of safety as the machine's safety related control system that includes the EZ-SCREEN LP.

The normally open safety outputs from an interface module provide a series connection of redundant contacts that form protective stop circuits for use in either single-channel or dual-channel control.

Dual-Channel Control

Dual-channel control provides the ability to electrically extend the safe switching point beyond the FSD contacts. With proper monitoring, this method of interfacing is capable of detecting certain failures in the control wiring between the safety stop circuit and the MPCEs. These failures include a short-circuit of one channel to a secondary source of energy or voltage, or a loss of the switching ability of one of the FSD outputs. Such failures may lead to a loss of redundancy, or to a complete loss of safety, if not detected and corrected.

The possibility of a failure to the wiring increases as the physical distance between the FSD safety stop circuits and the MPCEs increases, as the length or the routing of the interconnecting wires increases, or if the FSD safety stop circuits and the MPCEs are located in different enclosures. For this reason, dual-channel control with EDM monitoring should be used in any installation where the FSDs are located remotely from the MPCEs.

Single-Channel Control

Single-channel control uses a series connection of FSD contacts to form a safe switching point. After this point in the machine's safety-related control system, failures can occur that would result in a loss of the safety function (such as a short-circuit to a secondary source of energy or voltage). For this reason, single-channel control interfacing should be used only in installations where FSD safety stop circuits and the MPCEs are mounted within the same control panel, adjacent to each other, and are directly connected to each other; or where the possibility of such a failure can be excluded. If this cannot be achieved, then dual-channel control should be used.

Methods to exclude the possibility of these failures include, but are not limited to:

- Physically separating interconnecting control wires from each other and from secondary sources of power
- Routing interconnecting control wires in separate conduit, runs, or channels
- Locating all elements (modules, switches, and devices under control) within one control panel, adjacent to each other, and directly connected with short wires
- Properly installing multi-conductor cabling and multiple wires through strain relief fittings. Over-tightening of a strain-relief can cause short-circuits at that point.

- Using positive-opening or direct-drive components, installed and mounted in a positive mode

4.4.3 Machine Primary Control Elements

A machine primary control element (MPCE) is an electrically powered element that directly controls the normal operation of a machine in such a way that it is the last element (in time) to function when machine operation is to be initiated or arrested (per IEC 61496-1). Examples include motor contactors, clutch/brakes, valves, and solenoids.

If monitoring contacts are not available or do not meet the design requirement of being forced-guided (mechanically linked), it is recommended you:

- Replace the devices so that they are capable of being monitored; or
- Incorporate the EDM function into the circuit as close to the MPCE as possible (for example, monitor the FSDs); and
- Employ the use of well-ried, tested, and robust components, and generally accepted safety principles, including fault exclusion, into the design and installation to either eliminate, or reduce to an acceptable (minimal) level of risk, the possibility of undetected faults or failures that can result in the loss of the safety function.

The principle of fault exclusion allows the designer to design out the possibility of various failures and justify it through the risk assessment process to meet the required level of safety performance, such as the requirements of Category 2, 3, or 4. See ISO 13849-1/-2 for further information.

4.4.4 Preparing for System Operation

After the initial trip test has been accomplished, and the OSSD safety outputs and EDM connections have been made to the machine to be controlled, the EZ-SCREEN LP is ready for testing in combination with the guarded machine.

The operation of the EZ-SCREEN LP with the guarded machine must be verified before the combined System and machine may be put into service. To do this, a Qualified Person must perform the Commissioning Checkout Procedure.

4.4.5 Sensor Interchangeability

The figures and table below illustrate a wiring option that provides sensor interchangeability (or swapability)—the ability to install either sensor at either QD connection.

The resulting installation provides the ability to swap the emitter and receiver position, similar to a popular feature of Banner MACHINE-GUARD™, MINI-SCREEN®, and MICROSCREEN® safety light screens. This wiring option provides advantages during installation, wiring, and troubleshooting.

To use this option, connect all emitter wires in parallel (color-for-color) to the receiver cable via individual wires or the CSB.. splitter cordset .

Model CSB.. splitter cordsets and DEE2R.. double-ended cordsets allow easy interconnection between an EZ-SCREEN LP receiver and emitter, providing a single homerun cordset.

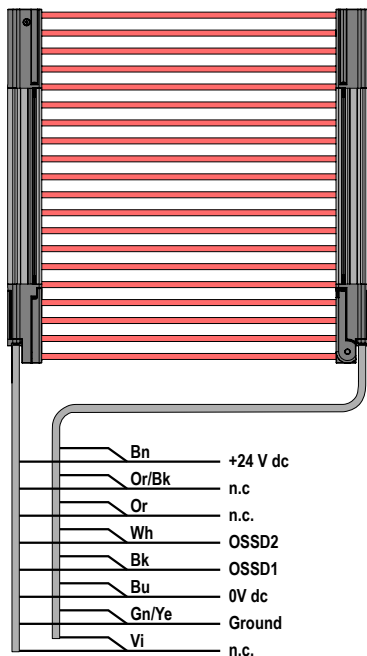

Figure 29. Individual Cordsets

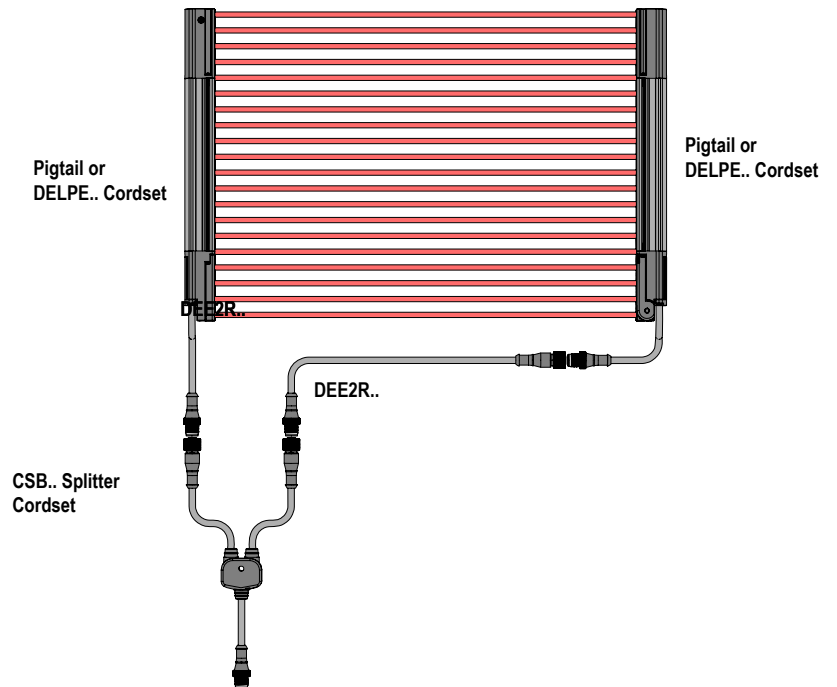

Figure 30. Splitter Cordsets

4.4.6 Commissioning Checkout

Perform this checkout procedure as part of the System installation after the System has been interfaced to the guarded machine, or whenever changes are made to the System (either a new configuration of the EZ-SCREEN LP or changes to the machine).



WARNING: Do Not Use Machine **Until** System Is Working Properly

If all of these checks cannot be **verified**, do not **attempt** to use the safety system that includes the Banner device and the guarded machine until the defect or problem has been corrected. **Attempts** to use the guarded machine under such **conditions** may result in serious bodily injury or death.

A Qualified Person must perform the procedure. Checkout results should be recorded and kept on or near the guarded machine as required by applicable standards.

To prepare the System for this checkout:

1. Examine the guarded machine to verify that it is of a type and design compatible with the EZ-SCREEN LP System. See [Examples: Inappropriate Applications](#) on page 8 for a list of misapplications.
2. Verify that the EZ-SCREEN LP is configured for the intended application.
3. Verify that the safety distance (minimum distance) from the closest danger point of the guarded machine to the defined area is not less than the calculated distance, per [Calculating the Safety Distance \(Minimum Distance\)](#) on page 10.
4. Verify that:
 - a) Access to any dangerous parts of the guarded machine is not possible from any direction not protected by the EZ-SCREEN LP System, hard (fixed) guarding, or supplemental safeguarding, and
 - b) It is not possible for a person to stand between the defined area and the dangerous parts of the machine, or
 - c) Supplemental safeguarding and hard (fixed) guarding, as described by the appropriate safety standards, are in place and functioning properly in any space (between the defined area and any hazard) which is large enough to allow a person to stand undetected by the EZ-SCREEN LP.
5. If used, verify that all reset switches are mounted outside and in full view of the guarded area, out of reach of anyone inside the guarded area, and that means of preventing inadvertent use is in place.
6. Examine the electrical wiring connections between the EZ-SCREEN LP OSSD outputs and the guarded machine's control elements to verify that the wiring meets the requirements stated in [Electrical Connections to the Guarded Machine](#) on page 32.
7. Inspect the area near the defined area (including work pieces and the guarded machine) for reflective surfaces (see [Adjacent Reflective Surfaces](#) on page 13). Remove the reflective surfaces if possible by relocating them, painting, masking or roughening them. Remaining problem reflections will become apparent during the Trip Test.
8. Verify that power to the guarded machine is Off. Remove all obstructions from the defined area. Apply power to the EZ-SCREEN LP System.
9. Observe the Status indicators and Diagnostic Display:
 - Lockout: Status flashing red; all others Off
 - Blocked: Status On red; one or more Zone indicators On red; Reset On amber
 - Clear: Status On green⁷; all Zone indicators On green; Reset On amber
10. A Blocked condition indicates that one or more of the beams is misaligned or interrupted. See the Alignment procedure in [Optical Alignment](#) on page 29 to correct this situation.
11. After the green and amber Status indicators are On, perform the trip test ([Trip Test](#) on page 31) on each sensing field to verify proper System operation and to detect possible optical short circuits or reflection problems. Do not **continue until** the EZ-SCREEN LP passes the trip test.



Important: Do not expose any individual to any hazard during the following checks.



WARNING: Before Applying Power to the Machine

Verify that the guarded area is clear of personnel and unwanted materials (such as tools) before applying power to the guarded machine. Failure to do so may result in serious bodily injury or death.

12. Apply power to the guarded machine and verify that the machine does not start up.
13. Interrupt (block) the defined area with the supplied test piece and verify it is not possible for the guarded machine to be put into motion while the beam(s) is blocked.
14. Initiate machine motion of the guarded machine and, while it is moving, use the supplied test piece to block the defined area. Do not attempt to insert the test piece into the dangerous parts of the machine. Upon blocking any beam, the dangerous parts of the machine must come to a stop with no apparent delay.
15. Remove the test piece from the beam; verify that the machine does not automatically restart, and that the initiation devices must be engaged to restart the machine.

⁷ The status indicator flashes green if reduced resolution is enabled.

16. Remove electrical power to the EZ-SCREEN LP. Both OSSD outputs should immediately turn Off, and the machine must not be capable of starting until power is re-applied to the EZ-SCREEN LP.
17. Test the machine stopping response time, using an instrument designed for that purpose, to verify that it is the same or less than the overall system response time specified by the machine manufacturer. A Banner Applications Engineer can recommend a suitable instrument.

Do not **continue operation until** the **entire** checkout procedure is complete and all problems are corrected.

4.5 Reference Wiring Diagrams

Other interfacing modules and solutions are available, see [Accessories](#) on page 49 and www.bannerengineering.com.



Note: For interfacing modules or remotely located safety I/O blocks where pin 5 of a 5-pin M12 QD is not earth ground, a 4-pin cordset where pin 5 is not physically present or is not electrically connected can be used (such as MQDEC-406SS double-ended cordset). In such situations, earth ground must be provided via the mounting brackets.

4.5.1 Generic **Emitter** Wiring Diagram

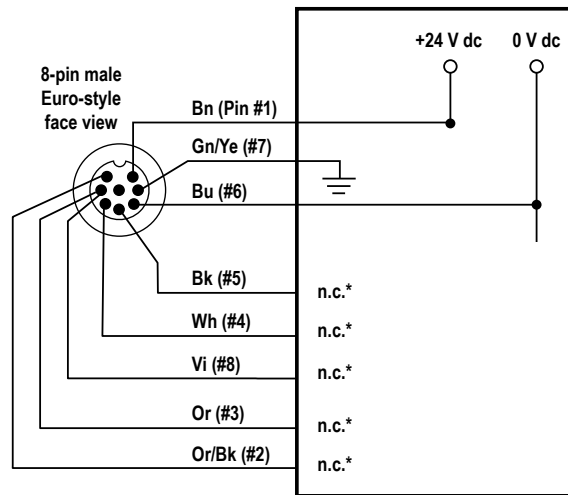

*NOTE: Pins 2, 3, 4 and 5 either are not connected, or are paralleled to same color wire from the 8-pin receiver cable.

Figure 31. Emitter—Generic hookup

4.5.2 Generic Wiring—Self-checking Safety Module, Safety Controller, Safety PLC

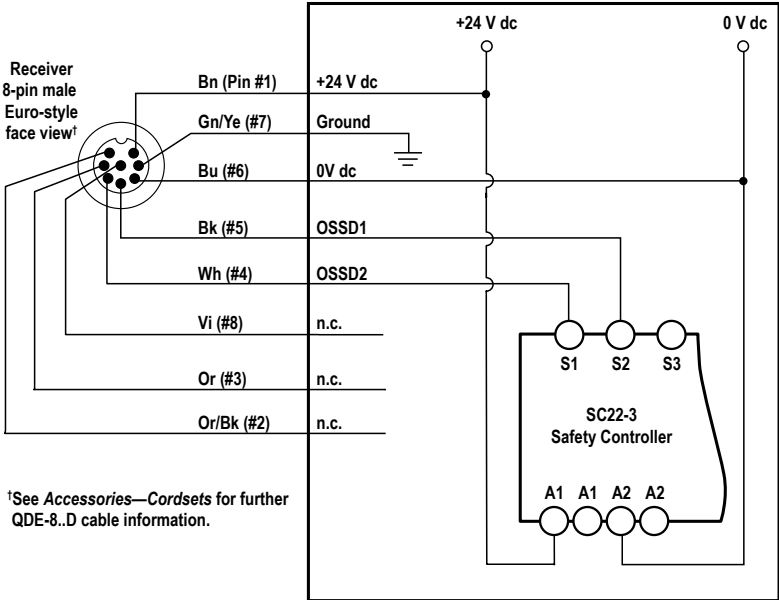

Figure 32. Generic wiring – self-checking Safety module, Safety Controller, Safety PLC (no monitoring, automatic reset)

5 System Operation

5.1 Security Protocol

Certain procedures for installing, maintaining, and operating the EZ-SCREEN LP must be performed by either Designated Persons or Qualified Persons.

A Designated Person is identified and designated in writing, by the employer, as being appropriately trained and qualified to perform system resets and the specified checkout procedures on the EZ-SCREEN LP. The Designated Person is empowered to:

- Perform manual resets and hold possession of the reset key
- Perform the Daily Checkout Procedure

A **Qualified** Person, by possession of a recognized degree or certificate of professional training, or by extensive knowledge, training, and experience, has successfully demonstrated the ability to solve problems relating to the installation of the EZ-SCREEN LP System and its integration with the guarded machine. In addition to everything for which the Designated Person is empowered, the Qualified Person is empowered to:

- Install the EZ-SCREEN LP System
- Perform all checkout procedures
- Make changes to the internal configuration settings
- Reset the System following a Lockout condition



5.2 Status Indicators

A variety of status indicators are clearly visible on each emitter and receiver face (see the introduction and [Optical Alignment](#) on page 29).

5.2.1 Emitter

A single bi-color Red/Green Status indicator shows whether power is applied, and whether the emitter is in a Run mode or a Lockout. A Diagnostic Display indicates a specific error code when the emitter is in Lockout; the display also momentarily indicates the scan code setting at power-up or when changed.

Table 5: Emitter Status Indicator Operation



| Operating Status | Status Indicator | 7-Segment Diagnostic Display |
|------------------|------------------|---|
| Power-up | Red Single Flash | Scan code flashes 3 times - sequentially  |
| Run Mode | Green |  |
| Lockout | Flashing Red | Displays error code (see Lockout Conditions on page 40) |

5.2.2 Receiver

A single bi-color red/green Status indicator shows when the OSSD outputs are On (green) or Off (red), or the System is in Lockout status (flashing red). An amber status indicator shows when the system is in Run mode or is waiting for a reset. The Diagnostic Display indicates a specific error code when the receiver is in Lockout. The Diagnostic Display also momentarily indicates the scan code setting at power-up or when changed.

Bi-color red/green Zone indicators that show whether a section of the defined area is aligned and clear, or is blocked and/or misaligned. All models have 8 Zone indicators, each of which indicates Blocked/Clear conditions for approximately 1/8 of the total light screen.

5.2.3 Receiver Status Indicator Operation - Trip Output

| Operating Mode | Reset Indicator | Status Indicator | Zone Indicators ⁸ | 7-Segment Diagnostic Display | OSSD Outputs |
|---------------------------------|-----------------|------------------|------------------------------|--|--------------|
| Power-up | Off | Single-Flash Red | All Single-Flash Red | Scan code flashes 3 times - sequentially  | Off |
| Alignment Mode - Beam 1 Blocked | Off | Red | Zone 1 Red, Others Off |  | Off |

⁸ If beam 1 is blocked, Zone indicators 2–8 will be Off, because beam 1 provides the synchronization signal for all the beams.

| Operating Mode | Reset Indicator | Status Indicator | Zone Indicators ⁸ | 7-Segment Diagnostic Display | OSSD Outputs |
|-------------------------------|-----------------|-------------------------------|------------------------------|---|--------------|
| Alignment Mode - Beam 1 Clear | Off | Red | Red or Green | Total number of blocked beams | Off |
| Run Mode - Clear | On | Solid Green or Flashing Green | All On Green |  | On |
| Run Mode - Blocked | On | Red | Red or Green | Total number of blocked beams | Off |
| Lockout | Off | Flashing Red | All Off | Displays error code (see Lockout Conditions on page 40) | Off |

5.3 Normal Operation

5.3.1 System Power-Up

When power is applied, each sensor conducts self-tests to detect critical internal faults, determine configuration settings, and prepare the EZ-SCREEN LP for operation. If either sensor detects a critical fault, scanning ceases, the receiver outputs remain Off and diagnostic information displays on the sensor's Diagnostic Display. If no faults are detected, the EZ-SCREEN LP automatically enters Alignment mode, and the receiver looks for an optical sync pattern from the emitter. If the receiver is aligned and receives the proper sync pattern, it enters Run mode and begins scanning to determine the blocked or clear status of each beam. No manual reset operation is required.

5.3.2 Run Mode

If any beams become blocked while the EZ-SCREEN LP is running, the receiver outputs turn Off within the stated EZ-SCREEN LP response time (see [General Specifications](#) on page 47). If all the beams then become clear, the receiver outputs come back On. No resets are needed. All required machine control resets are provided by the machine control circuit.

Internal Faults (Lockouts): If either sensor detects a critical fault, scanning ceases, the receiver outputs turn Off and diagnostic information displays on the sensor's Diagnostic Display. See [Lockout Conditions](#) on page 40 for resolution of error/fault conditions.

5.4 Periodic Checkout Requirements

To ensure continued reliable operation, the System must be checked out periodically.

At every **shift** change, power-up, and machine setup change, the Daily Checkout should be performed; this checkout may be performed by a Designated or Qualified Person.

Semi-annually, the System and its interface to the guarded machine should be thoroughly checked out; this checkout must be performed by a Qualified Person (see [Checkout Procedures](#) on page 45). A copy of these test results should be posted on or near the machine.

Whenever changes are made to the System (either a new configuration of the EZ-SCREEN LP System or changes to the machine), perform the Commissioning Checkout.



Note: Verify Proper Operation

The EZ-SCREEN LP can operate as it is designed only if it and the guarded machine are operating properly, both separately and together. It is the user's responsibility to verify this, on a regular basis, as instructed in [Checkout Procedures](#) on page 45. Failure to correct such problems can result in an increased risk of harm.

Before the System is put back into service, verify that the EZ-SCREEN LP System and the guarded machine perform exactly as outlined in the checkout procedures and any problem(s) are found and corrected.

⁸ If beam 1 is blocked, Zone indicators 2–8 will be Off, because beam 1 provides the synchronization signal for all the beams.

6 Troubleshooting and Maintenance

6.1 Lockout Conditions

A Lockout condition causes all of the EZ-SCREEN LP OSSD outputs to turn or remain Off, sending a stop signal to the guarded machine. Each sensor provides diagnostic error codes to assist in the identification of the cause(s) of lockouts (see *Receiver Error Codes* and *Emitter Error Codes*) or the Diagnostic Error Code label supplied in the documentation pack).

In addition, emitters internally monitor the infrared LEDs, and provide a health status indication whenever one of these components has degraded. The emitter will not lockout in this situation. Rather, the indication is intended to notify the user that the emitter should be replaced soon.

The following tables indicate a sensor lockout condition:

Table 6: Receiver Lockout Conditions

| | |
|---------------------------|-----------------------|
| Reset indicator | Off |
| Status indicator | Flashing Red |
| Zone indicators | Off |
| Diagnostic display | Error code (flashing) |



Table 7: Emitter Lockout Conditions

| | |
|---------------------------|-----------------------|
| Status indicator | Flashing Red |
| Diagnostic Display | Error code (flashing) |

6.2 Recovery Procedures







To recover from a Lockout condition, all errors must be corrected and power to the device cycled.

6.2.1 Emitter Error Codes









| Diagnostic Display ⁹ | Error Description | Cause of Error and Appropriate Action |
|---|--|---|
|  | Emitter Error This error can occur either due to excessive electrical noise or due to an internal failure. | <ul style="list-style-type: none"> Reset the emitter by cycling power If the error clears, perform the daily checkout procedure (per EZ-SCREEN Checkout Procedures: Shift and Daily Checkout Procedure; Daily Checkout Card). If the System checks out, resume operation. If the System fails, replace the emitter If the error continues, check the ground connection (see Cordsets on page 49) If the sensor has a good earth ground connection, check for electrical noise (see Electrical and Optical Noise on page 42) If the error persists, replace the emitter |
|  | Excessive Noise Error This error can occur due to excessive electrical noise. | <ul style="list-style-type: none"> Reset the emitter by cycling power If the error clears, perform the daily checkout procedure (per EZ-SCREEN Checkout Procedures: Shift and Daily Checkout Procedure; Daily Checkout Card). If the System checks out, resume operation. If the System fails, replace the emitter If the error continues, check the ground connection (see Cordsets on page 49) If the sensor has a good earth ground connection, check for electrical noise (see Electrical and Optical Noise on page 42) If the error persists, replace the emitter |
|  | Emitter LED Problem This is not an error. | This indication can occur due to a potential problem with an LED and is provided as an early warning indicator |
| "Axx"/"cxx", where "xx" are alpha-numeric characters | Advanced Diagnostics for the purpose of factory troubleshooting and repair; not intended for field troubleshooting. | If advanced diagnostic codes are inadvertently displayed, cycle power to the device to return to the standard error display |

⁹ Multiple-digit codes are sequential, followed by a pause.

6.2.2 Receiver Error Codes

| Diagnostic Display ¹⁰ | Error Description | Cause of Error and Appropriate Action |
|---|---|--|
|  | <p>Output Error</p> <p>Error is caused by:</p> <ul style="list-style-type: none"> • one or both outputs being shorted to a power supply (high or low) • by shorting OSSD 1 to OSSD 2 • by an overload (greater than 0.5 A) | <ul style="list-style-type: none"> • Disconnect the OSSD loads and reset the receiver. • If the error clears, the problem is in the OSSD load(s) or in the load wiring. • If the error continues with no load connected, replace the receiver. |
|  | <p>Reset Input Error</p> <p>This error occurs when the Reset switch is closed (or the wiring is shorted to +24 V) during power-up.</p> | <ul style="list-style-type: none"> • Verify that the reset switch is in the open position. • Reset the receiver per EZ-SCREEN Checkout Procedures: Shift and Daily Checkout Procedure. • If the error remains, disconnect the reset wire at pin 8; cycle power. • If the error clears, the problem is in the reset switch or in the wiring. • If the error continues when the reset wire is disconnected, replace the receiver. |
|  | <p>EDM Input Error</p> <p>Can occur for the following reasons:</p> <ul style="list-style-type: none"> • EDM wiring configuration does not match the EDM switch configuration • No connection to EDM connections • Both EDM inputs fail to respond within 250 ms of each other • Excessive noise on EDM inputs • Loose QD connection(s) | <ul style="list-style-type: none"> • Verify that the EDM configuration switches are set correctly and that the wiring is correct for the EDM type configured (see Machine Primary Control Elements on page 34). • Reset the receiver. • If the error continues, remove power to the guarded machine, disconnect the OSSD loads, disconnect the EDM input signals, configure EDM for No Monitoring (Machine Primary Control Elements on page 34) and conduct the Initial Checkout procedure in Initial Checkout Procedure on page 28. • If the error clears, the problem is in the external device contacts or wiring, or is a response-time problem of the external devices. Verify that the EDM wiring is correct and that the external devices meet the requirements described in Machine Primary Control Elements on page 34. • If the error continues, check for noise on the EDM inputs (see Electrical and Optical Noise on page 42). If error continues, replace the receiver |
|  | <p>Receiver Error</p> <p>This error can occur due to either excessive electrical noise or an internal failure.</p> | <ul style="list-style-type: none"> • Perform a reset per EZ-SCREEN Checkout Procedures: Shift and Daily Checkout Procedure. • If the error clears, perform a Daily Checkout procedure (per EZ-SCREEN Checkout Procedures: Shift and Daily Checkout Procedure; Daily Checkout Card) and if the System checks out, resume operation. If the System fails the Daily Checkout procedure, replace the receiver. • If the error continues, check the ground connection (pin 7). • If the sensor has a good earth ground connection to pin 7, perform the Initial Checkout procedure (per Initial Checkout Procedure on page 28). • If the error clears, check the external connections and configuration settings. • If the error continues, replace the receiver. |
|  | <p>DIP Switch Error</p> <p>This error can be caused by incorrect DIP switch settings or by changes to the DIP switch settings when the system is On.</p> | <ul style="list-style-type: none"> • Verify that the DIP switch settings are valid. Make any corrections necessary and perform a receiver reset. • If the error occurred due to a change of the DIP switch settings while the System was in Run mode, verify the switch settings and perform a receiver reset to resume operation with the new switch settings and modified System configuration. • If the error continues, replace the receiver. |
|  | <p>EDM1 Error</p> <p>This error can occur due to EDM 1 input signal failing to respond within 250 ms of the OSSDs changing state (On to Off).</p> | <ul style="list-style-type: none"> • Verify that the EDM wiring is correct and that the external devices meet the requirements described in Machine Primary Control Elements on page 34. • If the error continues, remove power to the guarded machine, disconnect the OSSD loads, disconnect the EDM input signals, configure EDM for No Monitoring (per Machine Primary Control Elements on page 34) and conduct the Initial Checkout procedure. • If the error clears, the problem is in the External Device contacts or wiring, or is a response-time problem of the external devices. Verify that the EDM wiring is correct and that the external devices meet the requirements described in Machine Primary Control Elements on page 34. • If the error continues, check for noise on the EDM inputs (see Electrical and Optical Noise on page 42). |

¹⁰ Multiple-digit codes are sequential, followed by a pause.

| Diagnostic Display ¹⁰ | Error Description | Cause of Error and Appropriate Action |
|---|---|--|
|  | EDM 2 Error EDM 2 configuration not valid (wiring or switch). | <ul style="list-style-type: none"> Verify that the EDM wiring is correct and that the external devices meet the requirements described in Machine Primary Control Elements on page 34 If the error continues, remove power to the guarded machine, disconnect the OSSD loads, disconnect the EDM input signals, configure EDM for no monitoring (per Machine Primary Control Elements on page 34) and conduct the initial checkout procedure. If the error clears, the problem is in the external device contacts or wiring, or is a response-time problem of the external devices. Verify that the EDM wiring is correct and that the external devices meet the requirements described in Machine Primary Control Elements on page 34. If the error continues, check for noise on the EDM inputs (see Electrical and Optical Noise on page 42). |
|  | Fixed Blanking Error This error occurs when beam(s) that have been blanked (programmed to ignore a fixed object) become clear when the object is removed or moved. | <ul style="list-style-type: none"> Reposition the object and perform a key reset (or cycle power). Re-program (teach) the fixed blanked object(s). |
|  | Programming Timeout Error This error occurs when the Fixed Blanking programming mode (teach) exceeds the ten-minute limit. | <ul style="list-style-type: none"> Re-program (teach) the fixed blanked object(s). |
|  | Cascade Configuration Error This error occurs when the configuration sequence is incorrectly followed, receiver(s) 2, 3 or 4 are configured, or receiver 1 is moved to a different position in the cascade. If this code appears for a noncascaded application, check EDM wiring. | <ul style="list-style-type: none"> The CSSI input channel(s) are shorted together or to another source of power or ground. Configure only the first receiver in the cascade (connected to the machine interface). All other receivers must be set for 2-channel EDM and trip output (T). Re-configure the first receiver to adapt System to changes or replacement of other receivers. <p> Note: In a cascaded System, all receivers are connected together, and all emitters are connected together.</p> |
|  | Excessive Noise Error – Reset Interface This error can occur due to excessive levels of electrical noise. | <ul style="list-style-type: none"> Perform a reset by cycling power. If the error clears, perform the daily checkout procedure (per EZ-SCREEN Checkout Procedures: Shift and Daily Checkout Procedure; Daily Checkout Card) and if the System checks out, resume operation. If the System fails the Daily Checkout procedure, replace the receiver. If the error continues, check the ground connection (pin 7). If the sensor has a good earth ground connection to pin 7, perform the Initial Checkout procedure (Trip Test on page 31). If the error clears, check for sources of electrical noise (see Electrical and Optical Noise on page 42). If the error continues, replace the receiver. |
|  | Excessive Noise Error – EDM Interface This error can occur due to excessive levels of electrical noise. | |
|  | Excessive Noise Error – Cascade Input This error can occur due to excessive levels of electrical noise. | |
|  | Cascade Input Simultaneity Operation of channels A and B mismatch > 3 seconds. | <ul style="list-style-type: none"> Check operation of Channel A and Channel B of cascade input. Cycle power or cycle the input. |
| "Axx"/"bxx"/"Fxx", where "xx" are alphanumeric characters | Advanced Diagnostics for the purpose of factory troubleshooting and repair; not intended for field troubleshooting. | If advanced diagnostic codes are inadvertently displayed, cycle power to the device. |

6.3 Electrical and Optical Noise

The EZ-SCREEN LP is designed and manufactured to be highly resistant to electrical and optical noise and to operate reliably in industrial settings. However, serious electrical and/or optical noise may cause a random Trip condition. In extreme electrical noise cases, a Lockout is possible. To minimize the effects of transitory noise, the EZ-SCREEN LP responds to noise only if the noise is detected on multiple consecutive scans.

If random nuisance Trips occur, check the following:

- Poor connection between the sensor and earth ground

¹⁰ Multiple-digit codes are sequential, followed by a pause.

- Optical interference from adjacent light screens or other photoelectrics
- Sensor input or output wires routed too close to noisy wiring

6.3.1 Checking for Sources of Electrical Noise

It is important that the light screen sensors have a good earth ground. Without this, the System can act like an antenna and random Trips and Lockouts can occur.

All EZ-SCREEN LP wiring is low voltage; running these wires alongside power wires, motor/servo wires, or other high-voltage wiring can inject noise into the EZ-SCREEN LP System. It is good wiring practice (and may be required by code) to isolate EZ-SCREEN LP wires from high-voltage wires.

1. Use the Banner model BT-1 Beam Tracker Alignment Aid (see [Accessories](#) on page 49) to detect electrical transient spikes and surges.
2. Cover the lens of the BT-1 with electrical tape to block optical light from entering the receiver lens.
3. Press the RCV button on the BT-1 and position the Beam Tracker on the wires going to the EZ-SCREEN LP or any other nearby wires.
4. Install proper transient suppression across the load to reduce the noise.

6.3.2 Checking for Sources of **Optical** Noise

1. Turn off the emitter or completely block the emitter.
2. Press the RCV button on the Banner BT-1 Beam Tracker Alignment Aid (see [Accessories](#) on page 49) and move it across the full length of the receiver's sensing window to check for light at the receiver.
3. If the BT-1's indicator lights, check for emitted light from other sources (other safety light screens, grids or points, or standard photoelectric sensors).

6.4 Maintenance and Service

6.4.1 Cleaning

EZ-SCREEN LP emitters and receivers are constructed of aluminum with a yellow painted finish and are rated IEC IP54. Lens covers are acrylic. Emitters and receivers are best cleaned using mild detergent or window cleaner and a soft cloth. Avoid cleaners containing alcohol, as they may damage the acrylic lens covers.

6.4.2 Replacement Parts

| Model | Description |
|-----------|--|
| STP-13 | 14 mm test piece (14 mm resolution systems) |
| STP-16 | 25 mm test piece (25 mm resolution systems) |
| DELPE-81D | Replacement for M12-terminated pigtail QD, as shipped with standard pigtail QD models; 8-conductor cable, 22 AWG; 0.3 m (1 ft) long; see Cordsets on page 49 for other lengths |

6.4.3 Banner Engineering Corp Limited Warranty

Banner Engineering Corp. warrants its products to be free from defects in material and workmanship for one year following the date of shipment. Banner Engineering Corp. will repair or replace, free of charge, any product of its manufacture which, at the time it is returned to the factory, is found to have been defective during the warranty period. This warranty does not cover damage or liability for misuse, abuse, or the improper application or installation of the Banner product.

THIS LIMITED WARRANTY IS EXCLUSIVE AND IN LIEU OF ALL OTHER WARRANTIES WHETHER EXPRESS OR IMPLIED (INCLUDING, WITHOUT LIMITATION, ANY WARRANTY OF MERCHANTABILITY OR FITNESS FOR A PARTICULAR PURPOSE), AND WHETHER ARISING UNDER COURSE OF PERFORMANCE, COURSE OF DEALING OR TRADE USAGE.

This Warranty is exclusive and limited to repair or, at the discretion of Banner Engineering Corp., replacement. IN NO EVENT SHALL BANNER ENGINEERING CORP. BE LIABLE TO BUYER OR ANY OTHER PERSON OR ENTITY FOR ANY EXTRA COSTS, EXPENSES, LOSSES, LOSS OF PROFITS, OR ANY INCIDENTAL, CONSEQUENTIAL OR SPECIAL DAMAGES RESULTING FROM ANY PRODUCT DEFECT OR FROM THE USE OR INABILITY TO USE THE PRODUCT, WHETHER ARISING IN CONTRACT OR WARRANTY, STATUTE, TORT, STRICT LIABILITY, NEGLIGENCE, OR OTHERWISE.

Banner Engineering Corp. reserves the right to change, modify or improve the design of the product without assuming any obligations or liabilities relating to any product previously manufactured by Banner Engineering Corp. Any misuse, abuse, or improper application or installation of this product or use of the product for personal protection applications when the product is identified as not intended for such purposes will void the product warranty. Any modifications to this product without prior express approval by Banner Engineering Corp will void the product warranties. All specifications published in this document are subject to change; Banner reserves the right to modify product specifications or update documentation at any time. Specifications and product information in English supersede that which is provided in any other language. For the most recent version of any documentation, refer to: www.bannerengineering.com.

6.4.4 Warranty Service

Contact Banner Engineering for troubleshooting of this device. Do not **attempt** any repairs to this Banner device; it contains no **field-replaceable** parts or components. If the device, device part, or device component is determined to be defective by a Banner Applications Engineer, they will advise you of Banner's RMA (Return Merchandise Authorization) procedure.



Important: If instructed to return the device, pack it with care. Damage that occurs in return shipping is not covered by warranty.

6.4.5 Manufacturing Date

Every EZ-SCREEN LP produced is marked with a code that defines the week and year of manufacture and manufacturing location. The code format (U.S. Standard format) is: YYWWL

- YY = year of manufacture, 2 digits
- WW = Week of manufacture, 2 digits
- L = Banner-specific code, 1 digit

Example: 1509H = 2015, week 9.

6.4.6 Disposal

Devices that are no longer in use should be disposed of according to the applicable national and local regulations.

7 Checkout Procedures

This section lists the schedule of checkout procedures and describes where each procedure is documented. Checkouts must be performed as described. Results should be recorded and kept in the appropriate place (for example, near the machine, and/or in a technical file).

7.1 Schedule of Checkouts

Checkout cards and this manual can be downloaded at <http://www.bannerengineering.com>.

| Checkout Procedure | When to Perform | Where to Find the Procedure | Who Must Perform the Procedure |
|------------------------|--|---|---------------------------------------|
| Trip Test | At Installation Any time the System, the guarded machine, or any part of the application is altered. | Trip Test on page 31 | Qualified Person |
| Commissioning Checkout | At Installation Whenever changes are made to the System (for example, either a new configuration of the EZ-SCREEN LP or changes to the guarded machine). | Commissioning Checkout on page 35 | Qualified Person |
| Shift/Daily Checkout | At each shift change Machine setup change Whenever the System is powered up During continuous machine run periods, this checkout should be performed at intervals not to exceed 24 hours. | Daily Checkout Card (Banner p/n 140045 for SLP.. stand-alone models) A copy of the checkout results should be recorded and kept in the appropriate place (for example, near or on the machine, in the machine's technical file). | Designated Person or Qualified Person |
| Semi-Annual Checkout | Every six months following System installation, or whenever changes are made to the System (either a new configuration of the EZ-SCREEN LP or changes to the machine). | Semi-Annual Checkout Card (Banner p/n 140047) A copy of the checkout results should be recorded and kept in the appropriate place (for example, near or on the machine, in the machine's technical file). | Qualified Person |

8 Specifications

8.1 Standard **Emitter** and Receiver Models—14 mm **Resolution**

Only standard yellow housing models are listed. Pigtail QD models (for example, SLPVAE14-270P8) have yellow PVC cable and black PVC QD overmold. For other models, see below.

See www.bannerengineering.com or call Banner Engineering for kit model numbering scheme.

Order one machine interface cordset for each emitter or receiver; see [Cordsets](#) on page 49.

| Defined Area | Models | | | Connection | Response Time | # Beams |
|--------------|----------------|----------------|-----------------------|---------------------------------|---------------|---------|
| | Emitter | Receiver | Emitter/Receiver Pair | | | |
| 270 mm | SLPVAE14-270P8 | SLPVAR14-270P8 | SLPVAP14-270P88 | 300 mm cable, 8-pin M12/Euro QD | 10.5 ms | 27 |
| | SLPVAE14-270P5 | SLPVAR14-270P5 | SLPVAP14-270P55 | 300 mm cable, 5-pin M12/Euro QD | | |
| 550 mm | SLPVAE14-550P8 | SLPVAR14-550P8 | SLPVAP14-550P88 | 300 mm cable, 8-pin M12/Euro QD | 16.5 ms | 55 |
| | SLPVAE14-550P5 | SLPVAR14-550P5 | SLPVAP14-550P55 | 300 mm cable, 5-pin M12/Euro QD | | |

Cabled QD models require mating cordsets with either an 8-pin M12/Euro-style connector (such as QDE-8..D, DEE2R-8..D, or CSB-M128..M1281; see [Cordsets](#) on page 49) or a 5-pin M12/Euro-style connector (such as QDE-5..D, or CSB-M125..M1251).

8.2 Standard **Emitter** and Receiver Models—25 mm **Resolution**

Only standard yellow housing models are listed. Pigtail QD models (for example, SLPVAE25-270P8) have yellow PVC cable and black PVC QD overmold. For other models, see below.

See www.bannerengineering.com or call Banner Engineering for kit model numbering scheme.

Order one machine interface cordset for each emitter or receiver; see [Cordsets](#) on page 49.

| Defined Area | Models | | | Connection | Response Time | # Beams |
|--------------|----------------|----------------|-----------------------|---------------------------------|---------------|---------|
| | Emitter | Receiver | Emitter/Receiver Pair | | | |
| 270 mm | SLPVAE25-270P8 | SLPVAR25-270P8 | SLPVAP25-270P88 | 300 mm cable, 8-pin M12/Euro QD | 8 ms | 14 |
| | SLPVAE25-270P5 | SLPVAR25-270P5 | SLPVAP25-270P55 | 300 mm cable, 5-pin M12/Euro QD | | |
| 550 mm | SLPVAE25-550P8 | SLPVAR25-550P8 | SLPVAP25-550P88 | 300 mm cable, 8-pin M12/Euro QD | 11 ms | 28 |
| | SLPVAE25-550P5 | SLPVAR25-550P5 | SLPVAP25-550P55 | 300 mm cable, 5-pin M12/Euro QD | | |

Cabled QD models require mating cordsets with either an 8-pin M12/Euro-style connector (such as QDE-8..D, DEE2R-8..D, or CSB-M128..M1281; see [Cordsets](#) on page 49) or a 5-pin M12/Euro-style connector (such as QDE-5..D, or CSB-M125..M1251).

8.3 General Specifications

Short Circuit Protection

All inputs and outputs are protected from short circuits to +24 V dc or dc common

Electrical Safety Class

III (per IEC 61140: 1997)

Safety Ratings

Type 4 per IEC 61496-1, -2
 Category 4 PL e per EN ISO13849-1
 SIL3 per IEC 61508; SIL CL3 per IEC 62061
 $PFH_d (1/hr) = 4 \times 10^{-9}$
 $MTTF_d (yrs) = 39$

Operating Range

0.1 m to 4 m (4 in to 13 ft) — Range decreases with use of mirrors and/or lens shields:

- Lens shields — approx 10% less range per shield
- Glass-surface mirrors — approx 8% less range per mirror

See the specific mirror datasheet for more information.

Resolution

14 mm or 25 mm, depending on model

Effective Aperture Angle (EAA)

Meets Type 4 requirements per IEC 61496-2, Section 5.2.9
 $\pm 2.5^\circ$ at 3 m

Operating Conditions

Temperature: 0 °C to +55 °C (+32 °F to +131 °F)
 Humidity: 95% maximum relative humidity (non-condensing)

Enclosure

Extruded aluminum housing with yellow polyester powder finish standard and well-sealed, rugged die-cast zinc end caps, acrylic lens cover, copolyester access cover

Optional clear anodized or static-dissipative nickel-plated finish available. Nickel-plated models also have static-dissipative acrylic lens cover and nickel-plated end caps.

Environmental Rating

IEC IP54

Shock and Vibration

Components have passed vibration and shock tests according to IEC 61496-1. This includes vibration (10 cycles) of 10-55 Hz at 0.35 mm (0.014 in) single amplitude (0.70 mm peak-to-peak) and shock of 10 g for 16 milliseconds (6,000 cycles).

Mounting Hardware

Emitter and receiver each are supplied with a pair of swivel endmounting brackets and two swivel side-mount brackets. Mounting brackets are 14-gauge/1.9 mm cold-rolled steel, black zinc finish.

Cables and Connections

See [Cordsets](#) on page 49 for recommended cables. If other cables are used with the EZ-SCREEN LP, the user must verify suitability of these cables for each application.

Certifications



8.3.1 Emitter or Receiver Product Identification Label

| | | | | |
|--|--|-------------------------|--|--|
| www.bannerengineering.com | M/N: SLPVAR14-270P8 | S/N: H00584011401201012 | SUPPLY: 24V dc +/- 15%, 0.150A dc max. | |
| RANGE: 0.1 - 4 m | TEMPERATURE RATING: 0 to 55 °C | ENCLOSURE RATING: IP54 | DEFINED AREA: 270mm | |
| RESOLUTION (RED, RES. OFF/ON): 14mm / 34mm | EFFECTIVE APERTURE ANGLE: $\leq 2.5^\circ$ at 3m | RESPONSE TIME: 10.5ms | OSSD RATING: $I_{max} = 0.5A$, $V_{on} > V_{in} - 1.5 V_{dc}$ | |
| SAFETY RATING: Type 4 per IEC 61496, EN ISO 13849-1 Cat. 4 PL e, SIL 3 per IEC 61508 | | | | |



The label is located on the back of the housing, near the cable end.

8.4 Emitter Specifications

Supply Voltage at the Device

24 V dc $\pm 15\%$ (use a SELV-rated power supply according to EN IEC 60950). The external voltage supply must be capable of buffering brief mains interruptions of 20 ms, as specified in IEC/EN 60204-1.

Residual Ripple

$\pm 10\%$ maximum

Supply Current

60 mA maximum

Status Indicators

One bi-color (Red/Green) Status Indicator: indicates operating mode, lockout or power Off condition

7-Segment Diagnostic indicator (1 digit): indicates proper operation, scan code, or error code

Wavelength of Emitter Elements

Infrared LEDs, 850 nm at peak emission

8.5 Receiver Specifications

Supply Voltage at the Device

24 V dc \pm 15% (use a SELV-rated power supply according to EN IEC 60950). The external voltage supply must be capable of buffering brief mains interruptions of 20 ms, as specified in IEC/EN 60204-1.

Residual Ripple

\pm 10% maximum

Supply Current (no load)

150 mA maximum, exclusive of OSSD1 and OSSD2 loads (up to additional 0.5 A each)

Response Time

Dependent on the number of sensing beams; see the models table for the number of beams and response time.

Recovery Time

Blocked to Clear (OSSDs turn On; varies with total number of sensing beams and whether Sync beam is blocked):

| Model | Beam 1 (Sync Beam) | All Other Beams |
|-------|--------------------|-----------------|
| 14 mm | 109 ms to 800 ms | 33 ms to 220 ms |
| 25 mm | 81 ms to 495 ms | 25 ms to 152 ms |

Output Signal Switching Devices (OSSDs)

Two redundant solid-state 24 V dc, 0.5 A max. sourcing OSSD (Output Signal Switching Device) safety outputs. (Use optional interface modules for ac or larger dc loads.)

ON-State voltage: \geq Vin-1.5 V dc

OFF-State voltage: 1.2 V dc max. (0 to 1.2 V dc)

Maximum load capacitance: 1.0 μ F

Minimum load inductance: 10 H

Leakage current: 0.50 mA maximum

OSSD test pulse width: 100 to 300 microseconds typical

OSSD test pulse period: 10 ms to 22 ms (varies with number of beams)

Switching current: 0 to 0.5 A

Status Indicators

Amber Reset Indicator: indicates whether the System is ready for operation or requires a reset

Bi-color (red/green) Status indicator: indicates general system and output status

Bi-color (red/green) Zone Status indicators: indicate condition (clear or blocked beam) of a defined group of beams

7-Segment Diagnostic indicator (1 digit): indicates proper operation, scan code, error code, or total number of blocked beams

Ambient Light Immunity

>10,000 lux at 5° angle of incidence

Strobe Light Immunity

Totally immune to one Federal Signal Corp. "Fireball" model FB2PST strobe

9 Accessories

Additional interfacing solutions and accessories continue to be added; refer to <http://www.bannerengineering.com> for a current list.

9.1 Cordsets

Machine interface cordsets provide power to the first emitter/receiver pair. Sensor interconnect cables provide power to subsequent emitters and receivers in the cascade. Cordsets typically have yellow PVC cables and black overmolds.

A removable disconnect (RD) is required to connect directly to the sensor housing. QD connectors are used for cable-to-cable interconnections and connections to other devices.

9.1.1 Connection Options



| For Models SLP.....P8 with a 300 mm 8-pin M12/Euro Pigtail QD | For Models SLP.....P5 with a 300 mm 5-pin M12/Euro Pigtail QD |
|---|--|
| Requires M12/Euro QD cordset: QDE, DEE2R, or CSM. | Requires M12/Euro QD cordset: QDE, DEE2R, or CSM. |
|  |  |

Figure 33. Connection Options

9.1.2 RD to Flying Leads Cordsets

Removable disconnect (RD) connector on one end; unterminated (cut to length) on other.

| Model Number | Length | Wire | Cordset Color Code | |
|-----------------------------------|-------------------|--|--------------------|-------------|
| For Emitters and Receivers | | | Color | Function |
| RDLP-815D | 4.6 m (15.1 ft) | 8-conductor cable, 22 AWG/0.33 mm ² | Brown | +24 V dc |
| RDLP-825D | 8 m (26.2 ft) | | Orange/Black | EDM 2 (Aux) |
| RDLP-850D | 15.3 m (50.2 ft) | | Orange | EDM 1 |
| RDLP-875D | 23 m (75.5 ft) | | White | OSSD 2 |
| RDLP-8100D | 30.5 m (100.1 ft) | | Black | OSSD 1 |
| | | | Blue | 0 V dc |
| | | Green/ Yellow | Gnd/Chassis | |
| | | | Violet | Reset |

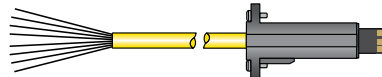

9.1.3 Euro/M12 to Flying Leads Cordsets

| M12/Euro QD connector on one end; unterminated (cut to length) on other to interface with guarded machine. PVC-jacketed overmold and cables. | | | |
|--|------------------|-----------------------------|---|
| Model | Length | Wire | Termination |
| For 8-Pin Emitters and Receivers | | | |
| QDE-815D | 4.5 m (15 ft) | 22 AWG/0.33 mm ² | 8-pin Euro-style female connector on one end; cut to length |
| QDE-825D | 7.6 m (24.9 ft) | | |
| QDE-830D | 9.1 m (30 ft) | | |
| QDE-850D | 15.2 m (49.8 ft) | | |

| M12/Euro QD connector on one end; unterminated (cut to length) on other to interface with guarded machine. PVC-jacketed overmold and cables. | | | |
|--|------------------|------|-------------|
| Model | Length | Wire | Termination |
| For 8-Pin Emitters and Receivers | | | |
| QDE-875D | 22.8 m (74.7 ft) | | |
| QDE-8100D | 30.4 m (99.7 ft) | | |

QDE-5..D 5-pin M12/Euro-style QD to **flying** lead cordsets—Use QDE-5... cordsets with sensors that have a 300 mm cable and 5-pin M12/Euro-style quick disconnect (models ending in P5). These cordsets have a M12/Euro-style QD connector on one end and are unterminated (cut to length) on the other end to interface with guarded machine. PVC jacketed overmold and cables.

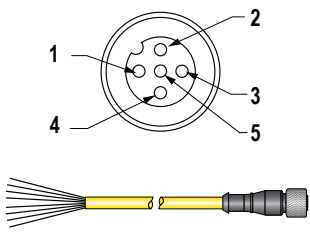
| Model | Length | Banner Cordset Pinout/Color Code | | | | M12 Connector (female face view) |
|-----------|-----------------|----------------------------------|-------|------------------|-------------------|---|
| | | Pin | Color | Emitter Function | Receiver Function |  |
| QDE-515D | 4.5 m (15 ft) | 1 | Brown | +24 V dc | +24 V dc | |
| QDE-525D | 7.6 m (25 ft) | 2 | White | no connection | OSSD2 | |
| QDE-550D | 15.2 m (50 ft) | 3 | Blue | 0 V dc | 0 V dc | |
| QDE-575D | 22.8 m (75 ft) | 4 | Black | no connection | OSSD1 | |
| QDE-5100D | 30.4 m (100 ft) | 5 | Gn/Ye | Gnd/Chassis | Gnd/Chassis | |

| Banner Cordset Pinout/Color Code | | | European M12 Specification ¹¹ | | | |
|----------------------------------|--------------|--------------|--|--------|--------------|---|
| Pin | Color | Function | Pin | Color | Function | Connector (female face view) |
| 1 | Brown | +24 V dc | 1 | White | +24 V dc |  |
| 2 | Orange/Black | EDM #2 (Aux) | 2 | Brown | EDM #2 (Aux) | |
| 3 | Orange | EDM #1 | 3 | Green | EDM #1 | |
| 4 | White | OSSD #2 | 4 | Yellow | OSSD #2 | |
| 5 | Black | OSSD #1 | 5 | Gray | OSSD #1 | |
| 6 | Blue | 0 V dc | 6 | Pink | 0 V dc | |
| 7 | Green/Yellow | Gnd/Chassis | 7 | Blue | Gnd/Chassis | |
| 8 | Violet | Reset | 8 | Red | Reset | |

9.1.4 Splitter Cordsets

Splitter cordsets are used for easy interconnection between an EZ-SCREEN LP receiver and its emitter, providing a single “homerun” cable. Model DEE2R-... double-ended cordsets may be used to extend the QD trunk or either branch. (Branch #1 and branch #2 cable sections are 300 mm/1 ft long.)

Model QDE-8..D or QDE-5..D single-ended cordsets may be used to extend the QD trunk for cut-to-length applications.

The 8-pin splitter cordsets allow for an easy interconnection between an 8-pin receiver and 8-pin emitter, and provide a single trunk cable for the optional interchangeable (“swappable”) connection.

¹¹ The European M12 Specification pin assignment and color codes are listed for reference only. Verify the suitability of these cables for an application.

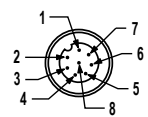
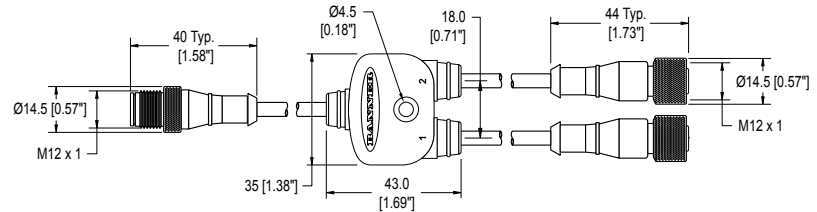
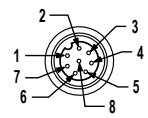
| 8-Pin Threaded M12/Euro-Style Splitter Cordsets—Flat Junction | | | |
|--|-----------------------------|-------------------|--|
| Model | Trunk (Male) | Branches (Female) | Pinout |
| CSB-M1280M1280 | No trunk | No branches | Male |
| CSB-M1281M1281 | 0.3 m (1 ft) | 2 x 0.3 m (1 ft) |  |
| CSB-M1288M1281 | 2.44 m (8 ft) | | |
| CSB-M12815M1281 | 4.57 m (15 ft) | | |
| CSB-M12825M1281 | 7.62 m (25 ft) | | |
| CSB-UNT825M1281 | 7.62 m (25 ft) Unterminated | | |
|  | | | Female |
| | | |  |
| | | | 1 = Brown 2 = Or/Bk 3 = Orange 4 = White 5 = Black 6 = Blue 7 = Grn/Ye 8 = Violet |

The 5-pin splitter cordsets allow for an easy interconnection between a 5-pin receiver and 5-pin emitter, and provide a single trunk cable for the optional interchangeable ("swapable") connection.

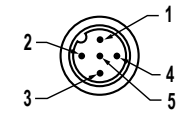
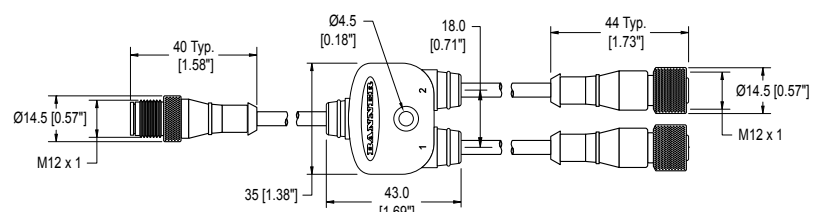
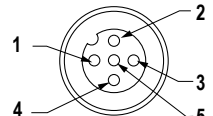
| 5-Pin Threaded M12/Euro-Style Splitter Cordsets—Flat Junction | | | |
|--|-----------------------------|-------------------|---|
| Model | Trunk (Male) | Branches (Female) | Pinout |
| CSB-M1251M1251 | 0.3 m (1 ft) | 2 x 0.3 m (1 ft) | Male |
| CSB-M1258M1251 | 2.44 m (8 ft) | |  |
| CSB-M12515M1251 | 4.57 m (15 ft) | | |
| CSB-M12525M1251 | 7.62 m (25 ft) | | |
| CSB-UNT525M1251 | 7.62 m (25 ft) Unterminated | | |
|  | | | |
| | | |  |
| | | | 1 = Brown 2 = White 3 = Blue 4 = Black 5 = Grn/Ye |

9.1.5 Male M12/Euro to Female M12/Euro QD Cordsets

Used for extending either the branch or trunk of a model CSB splitter cordset. M12/Euro-style connectors, female to male (rotateable). Overmold and cables are PVC-jacketed.

| Model | Length | Wire | Termination |
|------------|---------------|--|---|
| DEE2R-81D | 0.3 m (1 ft) | 8-conductor cable, 22 AWG/0.33 mm ² | M12/Euro QD fitting at each end, one male, one female |
| DEE2R-83D | 0.9 m (3 ft) | | |
| DEE2R-88D | 2.5 m (8 ft) | | |
| DEE2R-815D | 4.6 m (15 ft) | | |
| DEE2R-825 | 7.6 m (25 ft) | | |

| Model | Length | Wire | Termination |
|-------------|-----------------|------|-------------|
| DEE2R-830D | 9.1 m (30 ft) | | |
| DEE2R-850D | 15.2 m (50 ft) | | |
| DEE2R-875D | 22.9 m (75 ft) | | |
| DEE2R-8100D | 30.5 m (100 ft) | | |

9.1.6 DEE8-..D Adapter M12/Euro QD Cordsets

Used to convert the 8-pin M12/Euro style QD from the EZ-SCREEN LP to a 5-pin female M12/Euro QD for connection to a safety BUS gateway/node, a "smart" self-monitored safety module, safety controller, or safety PLC. Overmold and cables are PVC-jacketed.

| Model | Length | Wire | Pinout |
|-----------|---------------|--|--|
| DEE8-41D | 0.3 m (1 ft) | 4-conductor cable, 22 AWG/0.33 mm ² | <p>8-Pin Female to 5-Pin Male</p> <p>1 ↔ 1</p> <p>2 ↘</p> <p>3 ↘</p> <p>4 ↔ 2</p> <p>5 ↔ 3</p> <p>6 ↔ 4</p> <p>7 ↔ 5</p> <p>8</p> |
| DEE8-48D | 2.5 m (8 ft) | | |
| DEE8-415D | 4.6 m (15 ft) | | |
| DEE8-425D | 7.6 m (25 ft) | | |
| DEE8-51D | 0.3 m (1 ft) | 5-conductor cable, 22 AWG/0.33 mm ² | <p>DEE8-4..D cordsets do not have the pin 5 GND/chassis connection. GND/chassis connection should be made via the mounting hardware.</p> |
| DEE8-58D | 2.5 m (8 ft) | | |
| DEE8-515D | 4.6 m (15 ft) | | |
| DEE8-525D | 7.6 m (25 ft) | | |

9.1.7 Bulkhead Connector

Connector for panel connection of EZ-SCREEN LP emitter and receiver cables.

| Model | Connection | Dimensions |
|-----------|---|------------|
| PMEF-810D | 8-pin Euro-style female connector 3 m (10 ft) wires, cut to length (Banner color code); 22 AWG/0.33 mm ² | |

9.2 Interface Modules

IM-T-..A interface modules provide forced-guided, mechanically-linked relay (safety) outputs for the EZ-SCREEN LP System See Banner datasheet p/n [62822](#) for more information.

| Model | Description |
|----------|---|
| IM-T-9A | Interface module, 3 normally open (N.O.) redundant-output 6 amp contacts |
| IM-T-11A | Interface module, 2 normally open (N.O.) redundant-output 6 amp contacts, plus 1 normally closed (N.C.) auxiliary contact |

9.3 Contactors

The normally closed contacts are used in an external device monitoring (EDM) circuit. If used, two contactors per EZ-SCREEN LP System are required. See datasheet p/n [111881](#) for additional options and more information.

| Model | Description |
|------------------|--|
| 11-BG00-31-D-024 | 10 amp positive-guided contactor, 3 N.O., 1 N.C. |
| BF1801L024 | 18 amp positive-guided contactor, 3 N.O., 1 N.C. (N.C. contact rated at 10 amps) |

9.4 Muting Module

Provides the muting capability for the EZ-SCREEN LP. See Banner manuals p/n 63517 or 116390 for more information and additional cabling options.

| Model | Description |
|------------|---|
| MMD-TA-11B | DIN-mount Muting module |
| MMD-TA-12B | 2 N.O. safety outputs (6 amps), 2 or 4 muting inputs, SSI, override input; IP20; terminal connections |
| | 2 OSSD outputs, 2 or 4 muting inputs, SSI, override input; IP20; terminal connections |

9.5 Safety Controllers

| Model | Terminal Type | Description |
|-----------|----------------------|---|
| XS26-2xx | Screw-type terminals | Expandable Safety Controller. Ethernet and Display options available. 26 convertible I/Os and 2 Solid State Safety Outputs. |
| SC26-2xx | Screw-type terminals | Non-Expandable Safety Controller. Ethernet and Display options available. 26 convertible I/Os and 2 Solid State Safety Outputs. |
| SC22-3-S | Screw-type terminals | 10 Auxiliary outputs, includes external memory XM card |
| SC22-3-C | Clamp-type terminals | |
| SC22-3E-S | Screw-type terminals | 10 Auxiliary outputs, includes external memory XM card, plus EtherNet/IP and Modbus TCP, 32 virtual outputs |
| SC22-3E-C | Clamp-type terminals | |

9.6 Snap-On Lens Shields





Impact-resistant copolyester lens shields snap easily over entire length of sensor housing, protecting against metal cutting fluids and other chemicals. The lens shields are not sealed at the top and bottom, and decrease sensing range by approximately 15% when they are protecting both the emitter and receiver.

Order one per sensor.

| Sensor Model | Lens Shield Model | |
|---------------|-------------------|---|
| SLPVA..-270.. | LPSS-270 |  |
| SLPVA..-550.. | LPSS-550 | |

9.7 EZ-LIGHT® for EZ-SCREEN®

Provides clear, 360° indication of the of the EZ-SCREEN receiver's output status. Use with a CSB splitter cable and optional DEE2R double-ended cables. See data sheet p/n 121901 for more information.

| Models | Construction | Connector/LED Function/Inputs |
|--|--|---|
|  M18RGX8PQ8 ¹² | Nickel-plated brass housing, M18x1 thread; thermoplastic lens Fully encapsulated IP67 | 8-pin Euro-style Integral QD Red/Green indication follows OSSD output of the EZ-SCREEN receiver ON Red:—Power ON Beam Blocked or Lockout ON Green:—Power ON Beam Clear PNP (Sourcing) |
|  T18RGX8PQ8 | Thermoplastic polyester housing, thermoplastic lens Fully encapsulated IP67 | |
|  T30RGX8PQ8 | | |
|  K30LRGX8PQ8 | Polycarbonate housing, 30 mm thermoplastic dome, 22 mm base mount Fully encapsulated, IP67 | |
|  K50LRGX8PQ8 | Polycarbonate housing, 50 mm thermoplastic dome, 30 mm base mount Fully encapsulated, IP67 | |
|  K80LRGX8PQ8 | Polycarbonate housing, 50 mm thermoplastic dome, flat or DIN mount Encapsulated electronics, IP67 | |

9.8 MSA Series Stands

- Provides mounting T-slots with 20 mm dimension between slots
- Base included. Available without a base by adding the suffix NB to the model number (for example, MSA-S42-1NB).

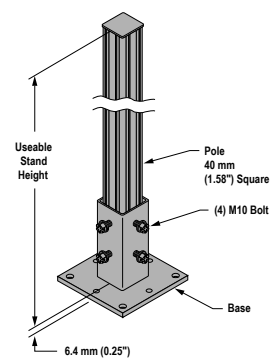
| Stand Model | Pole Height | Useable Stand Height | Overall Stand Height | |
|-------------|------------------|----------------------|----------------------|--|
| MSA-S24-1 | 610 mm (24 in) | 483 mm (19 in) | 616 mm (24.25 in) |  |
| MSA-S42-1 | 1067 mm (42 in) | 940 mm (37 in) | 1073 mm (42.25 in) | |
| MSA-S66-1 | 1676 mm (66 in) | 1550 mm (61 in) | 1682 mm (66.25 in) | |
| MSA-S84-1 | 2134 mm (84 in) | 2007 mm (79 in) | 2140 mm (84.25 in) | |
| MSA-S105-1 | 2667 mm (105 in) | 2667 mm (100 in) | 2673 mm (105.25 in) | |

¹² Available in a kit that includes one M18 EZ-LIGHT, one SMB18A mounting bracket, and hardware for mounting to the side channel of an EZ-SCREEN housing (kit model number EZA-M18RGX8PQ8).

9.9 MSM Series Corner Mirrors

- Compact for light-duty applications
- Rear-surface glass mirrors are rated at 85% efficiency. The total sensing range decreases by approximately 8% per mirror. See mirror data sheet p/n 43685 or <http://www.bannerengineering.com> for further information.
- Mounting brackets may be inverted from the positions shown (flanges pointing "inward" instead of "outward," as shown). When this is done, dimension L1 decreases by 57 mm.
- MSAMB adapter bracket kit included with each MSA stand.

| Mirror Model | Defined Area Length | Reflective Area Y | Mounting L1 | Mounting L2 | |
|--------------|---------------------|-------------------|-------------------|------------------|---|
| MSM8A | 150 mm (5.9 in) | 267 mm (10.5 in) | 323 mm (12.7 in) | 292 mm (11.5 in) | <p>The diagram shows a corner mirror assembly with a vertical reflective surface. Key dimensions are labeled: L1 is the total mounting height, L2 is the mounting height excluding the top bracket, Y is the reflective area height, 53.8 mm (2.12") is the top bracket height, 72.9 mm (2.87") is the mounting base width, and 50.8 mm (2.00") is the mounting base height. It also indicates 'M4 x 10 mm Screw (8 supplied)'.</p> |
| MSM12A | 300 mm (11.8 in) | 356 mm (14 in) | 411 mm (16.2 in) | 381 mm (15 in) | |
| MSM20A | 450 mm (17.7 in) | 559 mm (22 in) | 615 mm (24.2 in) | 584 mm (23 in) | |
| MSM24A | 600 mm (23.6 in) | 660 mm (26 in) | 716 mm (28.2 in) | 686 mm (27 in) | |
| MSM32A | 750 mm (29.5 in) | 864 mm (34 in) | 919 mm (36.2 in) | 889 mm (35 in) | |
| MSM36A | 900 mm (35.4 in) | 965 mm (38 in) | 1021 mm (40.2 in) | 991 mm (39 in) | |
| MSM44A | 1050 mm (41.3 in) | 1168 mm (46 in) | 1224 mm (48.2 in) | 1194 mm (47 in) | |
| MSM48A | 1200 mm (47.2 in) | 1270 mm (50 in) | 1326 mm (52.2 in) | 1295 mm (51 in) | |

9.10 SSM Series Corner Mirrors

- Robust for heavy-duty applications
- Extra wide for use with long-range optical safety systems
- Rear-surface glass mirrors are rated at 85% efficiency. The total sensing range decreases by approximately 8% per mirror. See mirror datasheet p/n 61934 or www.bannerengineering.com for further information.
- Stainless steel reflective surface models are also available. See datasheet p/n 67200.
- Robust construction, two mounting brackets and hardware included.
- EZA-MBK-2 adapter bracket is required for use with MSA Series stand, refer to the mounting bracket accessories list.
- Brackets may be inverted from the positions shown, decreasing dimension L1 by 58 mm (2.3 in).





| Mirror Model ¹³ | Defined Area Length | Reflective Area Y | Mounting 1 | Mounting L2 | |
|----------------------------|---------------------|-------------------|-------------------|-------------------|--|
| SSM-200 | 150 mm (5.9 in) | 200 mm (7.9 in) | 278 mm (10.9 in) | 311 mm (12.2 in) | |
| SSM-375 | 300 mm (11.8 in) | 375 mm (14.8 in) | 486 mm (19.1 in) | 453 mm (17.8 in) | |
| SSM-550 | 450 mm (17.7 in) | 550 mm (21.7 in) | 661 mm (26.0 in) | 628 mm (24.7 in) | |
| SSM-675 | 600 mm (23.6 in) | 675 mm (26.6 in) | 786 mm (31.0 in) | 753 mm (29.6 in) | |
| SSM-825 | 750 mm (29.5 in) | 825 mm (32.5 in) | 936 mm (36.9 in) | 903 mm (35.6 in) | |
| SSM-975 | 900 mm (35.4 in) | 975 mm (38.4 in) | 1086 mm (42.8 in) | 1053 mm (41.5 in) | |
| SSM-1100 | 1050 mm (41.3 in) | 1100 mm (43.3 in) | 1211 mm (47.7 in) | 1178 mm (46.4 in) | |
| SSM-1275 | 1200 mm (47.2 in) | 1275 mm (50.2 in) | 1386 mm (54.6 in) | 1353 mm (53.3 in) | |
| SSM-1400 | 1350 mm (53.1 in) | 1400 mm (55.1 in) | 1511 mm (59.5 in) | 1478 mm (58.2 in) | |
| SSM-1550 | 1500 mm (59.0 in) | 1550 mm (61.0 in) | 1661 mm (65.4 in) | 1628 mm (64.1 in) | |
| SSM-1750 | 1650 mm (65.0 in) | 1750 mm (68.9 in) | 1861 mm (73.3 in) | 1828 mm (72.0 in) | |
| SSM-1900 | 1800 mm (70.9 in) | 1900 mm (74.8 in) | 2011 mm (79.2 in) | 1978 mm (77.9 in) | |

9.11 Accessory Mounting Bracket

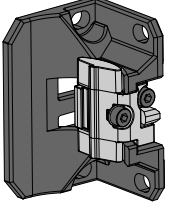

Contact Banner Engineering for more information.

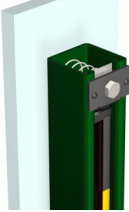
| Model | Description | |
|------------|---|--|
| LPA-MBK-10 | <ul style="list-style-type: none"> • End-mount bracket • 14 ga (1.9 mm) steel, black zinc plated | |
| LPA-MBK-11 | <ul style="list-style-type: none"> • End-mount bracket • 360° rotation • 14 ga (1.9 mm) steel, black zinc plated | |
| LPA-MBK-12 | <ul style="list-style-type: none"> • Side-mount bracket • +10° / -30° rotation • 14 ga (1.9 mm) steel, black zinc plated | |
| LPA-MBK-13 | <ul style="list-style-type: none"> • Adaptor for side-mount bracket LPA-MBK-12 • Reorients sensor rotation by 90° (+10° / -30°) • 14 ga (1.9 mm) steel, black zinc plated • Includes 1 bracket and hardware | |

¹³ Stainless steel reflective surface models are available by adding model number suffix "-S" (for example, SSM-375-S); range reduction for these models is approximately 30% per mirror. See datasheet p/n 67200.

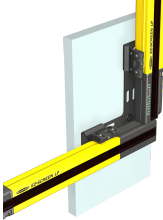
| Model | Description | |
|--------------|---|--|
| LPA-MBK-16 | <ul style="list-style-type: none"> Side-mounting bracket provides a mounting option that is fully adjustable (lateral and +15/-20° rotational) from the face of the sensor and allows "no blind zone" mounting with minimal or no "gaps" in detection Zinc diecast Includes 1 bracket and hardware Order two or three LPA-MBK-16 brackets per sensor |  |
| LPA-MBK-20 | <ul style="list-style-type: none"> Universal adapter bracket for mounting to engineered/slotted aluminum framing (for example, 80/20™, Bosch) Retrofit for Banner MS/US/MG; clearance for M4 and M6 hardware Use with LPA-MBK-11, -12, or -13 12 ga (2.66 mm) steel, black zinc plated Includes 1 bracket and hardware |  |
| LPA-MBK-22 | <ul style="list-style-type: none"> End-cap bracket for mounting sensor inside Unistrut® metal framing; uses end-cap plates from bracket LPA-MBK-11 Fits Unistrut P1000 size, with M6 or 1/4" channel nuts 14 ga (1.90 mm) steel, black zinc plated; diecast zinc clamps Includes 2 brackets and hardware |  |
| LPA-MBK-Pxxx | <ul style="list-style-type: none"> L-shaped bracket for one emitter or receiver protects sensor from weld flash, impact. Sized to match sensor length; replace "xxx" in model number with sensor size (for example, LPAMBK- P270 for use with sensor SLP.-270.); bracket studs mate with side-mount brackets LPA-MBK-12, included with sensor. Corner notch accommodates cable routing. +10°/ -30° sensor rotation 12 ga (2.66 mm) steel, black zinc plated or painted Includes 1 bracket and hardware |  |

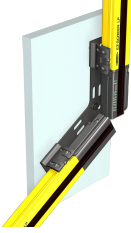
| Model | Description | |
|------------|--|---|
| LPA-MBK-21 | <ul style="list-style-type: none"> Pivoting "L" bracket system for two cascaded emitters or receivers; uses clamps from sidemount bracket LPA-MBK-12. Order one per cascaded joint; set includes two brackets. Adjustable 90° to 180° orientation; resolution is 25 mm at < 135°, 28 mm at 120°, and 32 mm at 90° configuration. (Resolution between sensors at the pivot point can be as large as 32 mm.) +10°/ -30° sensor rotation 14 ga (1.9 mm) steel, black zinc plated Cascade brackets join two sensors. Each model number is one set of 2 (mirror image) brackets and hardware. |  |
| LPA-MBK-90 | <ul style="list-style-type: none"> Fixed angled "L" bracket for two cascaded emitters or receivers; uses clamps from sidemount bracket LPA-MBK-12. Order one per cascaded joint; set includes two brackets. Fixed 90° orientation; maintains 25 mm resolution between sensor pairs +10°/ -30° sensor rotation 14 ga (1.9 mm) steel, black zinc plated Cascade brackets join two sensors. Each model number is one set of 2 (mirror image) brackets and hardware. |  |

| Model | Description | |
|-------------|---|---|
| LPA-MBK-120 | <ul style="list-style-type: none"> Fixed angled "L" bracket for two cascaded emitters or receivers; uses clamps from sidemount bracket LPA-MBK-12. Order one per cascaded joint; set includes two brackets. Fixed 120° orientation; maintains 25 mm resolution between sensor pairs +10°/ -30° sensor rotation 14 ga (1.9 mm) steel, black zinc plated Cascade brackets join two sensors. Each model number is one set of 2 (mirror image) brackets and hardware. |  |
| LPA-MBK-135 | <ul style="list-style-type: none"> Fixed angled "L" bracket for two cascaded emitters or receivers; uses clamps from sidemount bracket LPA-MBK-12. Order one per cascaded joint; set includes two brackets. Fixed 135° orientation; maintains 25 mm resolution between sensor pairs +10°/ -30° sensor rotation 14 ga (1.9 mm) steel, black zinc plated Cascade brackets join two sensors. Each model number is one set of 2 (mirror image) brackets and hardware. |  |
| LPA-MBK-180 | <ul style="list-style-type: none"> Fixed inline (straight) bracket for two cascaded emitters or receivers; uses clamps from sidemount bracket LPA-MBK-12. Order one per cascaded joint; set includes two brackets. Fixed 180° orientation; maintains 25 mm resolution between sensor pairs +10°/ -30° sensor rotation 14 ga (1.9 mm) steel, black zinc plated Cascade brackets join two sensors. Each model number is one set of 2 (mirror image) brackets and hardware. |  |

9.12 Alignment Aids

| Model | Description | |
|---------------|---|---|
| LAT-1-LP | Self-contained visible-beam laser tool for aligning any EZ-SCREEN LP emitter/receiver pair. Includes retroreflective target material and mounting clip. |  |
| LPA-LAT-2 | Replacement adaptor (clip) hardware for EZ-SCREEN LP models | |
| LPA-LAT-1 | Clip-on retroreflective LAT target | |
| BRT-THG-2-100 | 2 inch retroreflective tape, 100 ft | |
| BT-1 | Beam Tracker | |

9.13 Literature

The following documentation is supplied with each EZ-SCREEN LP receiver. Additional copies are available at no charge; contact Banner Engineering or visit www.bannerengineering.com.

| Part Number | Description |
|-------------|--|
| 197310 | EZ-SCREEN LP Limited Function Safety Light Screen Instruction Manual |
| 140045 | Checkout Procedure Card (Daily)—Stand-Alone Systems |
| 140047 | Checkout Procedure Card (Semi-Annual) |
| 147360 | EZ-SCREEN LP Bracket Supplement |

10 Standards and Regulations

The list of standards below is included as a convenience for users of this Banner device. Inclusion of the standards below does not imply that the device complies specifically with any standard, other than those specified in the Specifications section of this manual.

10.1 Applicable U.S. Standards

| | |
|--|---|
| ANSI B11.0 Safety of Machinery, General Requirements, and Risk Assessment | ANSI B11.15 Pipe, Tube, and Shape Bending Machines |
| ANSI B11.1 Mechanical Power Presses | ANSI B11.16 Metal Powder Compacting Presses |
| ANSI B11.2 Hydraulic Power Presses | ANSI B11.17 Horizontal Extrusion Presses |
| ANSI B11.3 Power Press Brakes | ANSI B11.18 Machinery and Machine Systems for the Processing of Coiled Strip, Sheet, and Plate |
| ANSI B11.4 Shears | ANSI B11.19 Performance Criteria for Safeguarding |
| ANSI B11.5 Iron Workers | ANSI B11.20 Manufacturing Systems |
| ANSI B11.6 Lathes | ANSI B11.21 Machine Tools Using Lasers |
| ANSI B11.7 Cold Headers and Cold Formers | ANSI B11.22 Numerically Controlled Turning Machines |
| ANSI B11.8 Drilling, Milling, and Boring | ANSI B11.23 Machining Centers |
| ANSI B11.9 Grinding Machines | ANSI B11.24 Transfer Machines |
| ANSI B11.10 Metal Sawing Machines | ANSI/RIA R15.06 Safety Requirements for Industrial Robots and Robot Systems |
| ANSI B11.11 Gear Cutting Machines | ANSI NFPA 79 Electrical Standard for Industrial Machinery |
| ANSI B11.12 Roll Forming and Roll Bending Machines | ANSI/PMMI B155.1 Package Machinery and Packaging-Related Converting Machinery — Safety Requirements |
| ANSI B11.13 Single- and Multiple-Spindle Automatic Bar and Chucking Machines | |
| ANSI B11.14 Coil Slitting Machines | |

10.2 OSHA Regulations

OSHA Documents listed are part of: Code of Federal Regulations Title 29, Parts 1900 to 1910

OSHA 29 CFR 1910.212 General Requirements for (Guarding of) All Machines

OSHA 29 CFR 1910.147 The Control of Hazardous Energy (lockout/tagout)

OSHA 29 CFR 1910.217 (Guarding of) Mechanical Power Presses

10.3 International/European Standards

| | |
|---|---|
| ISO 12100 Safety of Machinery – General Principles for Design — Risk Assessment and Risk Reduction | IEC 60204-1 Electrical Equipment of Machines Part 1: General Requirements |
| ISO 13857 Safety Distances . . . Upper and Lower Limbs | IEC 61496 Electro-sensitive Protection Equipment |
| ISO 13850 (EN 418) Emergency Stop Devices, Functional Aspects – Principles for Design | IEC 60529 Degrees of Protection Provided by Enclosures |
| ISO 13851 (EN 574) Two-Hand Control Devices – Functional Aspects – Principles for Design | IEC 60947-1 Low Voltage Switchgear – General Rules |
| IEC 62061 Functional Safety of Safety-Related Electrical, Electronic and Programmable Control Systems | IEC 60947-5-1 Low Voltage Switchgear – Electromechanical Control Circuit Devices |
| ISO 13849-1 Safety-Related Parts of Control Systems | IEC 60947-5-5 Low Voltage Switchgear – Electrical Emergency Stop Device with Mechanical Latching Function |
| ISO 13855 (EN 999) The Positioning of Protective Equipment in Respect to Approach Speeds of Parts of the Human Body | IEC 61508 Functional Safety of Electrical/Electronic/Programmable Electronic Safety-Related Systems |
| ISO 14119 (EN 1088) Interlocking Devices Associated with Guards – Principles for Design and Selection | |

10.4 Contact Us

Corporate Headquarters

Address:
Banner Engineering Corporate
9714 Tenth Avenue North
Minneapolis, Minnesota 55441, USA

Phone: +1 763 544 3164
Website: www.bannerengineering.com

Europe

Address:
Banner Engineering EMEA
Park Lane Culliganlaan 2F
Diegem B-1831, Belgium

Phone: +32 (0)2 456 0780
Website: www.bannerengineering.com/eu
Email: mail@bannerengineering.com

Turkey

Address:
Banner Engineering Turkey
Barbaros Mah. Uphill Court Towers A Blok D:49
34746 Batı Ataşehir İstanbul Türkiye

Phone: +90 216 688 8282
Website: www.bannerengineering.com.tr
Email: turkey@bannerengineering.com.tr

India

Address:
Banner Engineering India Pune Head Quarters
Office No. 1001, 10th Floor Sai Capital, Opp. ICC Senapati Bapat Road
Pune 411016, India

Phone: +91 (0) 206 640 5624
Website: www.bannerengineering.co.in
Email: salesindia@bannerengineering.com

Mexico

Address:
Banner Engineering de Mexico Monterrey Head Office
Edificio VAO Av. David Alfaro Siqueiros No.103 Col. Valle Oriente C.P.66269
San Pedro Garza Garcia, Nuevo Leon, Mexico

Phone: +52 81 8363 2714 or 01 800 BANNERE (toll free)
Website: www.bannerengineering.com.mx
Email: mexico@bannerengineering.com

Brazil

Address:
Banner do Brasil
Rua Barão de Teffé nº 1000, sala 54
Campos Eliseos, Jundiaí - SP, CEP.: 13208-761, Brasil

Phone: +1 763 544 3164
Website: www.bannerengineering.com.br
Email: brasil@bannerengineering.com

China

Address:
Banner Engineering Shanghai Rep Office
Xinlian Scientific Research Building Level 12, Building 2
1535 Hongmei Road, Shanghai 200233, China

Phone: +86 212 422 6888
Website: www.bannerengineering.com.cn
Email: sensors@bannerengineering.com.cn

Japan

Address:
Banner Engineering Japan
Cent-Urban Building 305 3-23-15 Nishi-Nakajima Yodogawa-Ku
Osaka 532-0011, Japan

Phone: +81 (0)6 6309 0411
Website: www.bannerengineering.co.jp
Email: mail@bannerengineering.co.jp

Taiwan

Address:
Banner Engineering Taiwan
8F-2, No. 308 Section 1, Neihu Road
Taipei 114, Taiwan

Phone: +886 (0)2 8751 9966
Website: www.bannerengineering.com.tw
Email: info@bannerengineering.com.tw

11 Glossary

A

ANSI (American **National Standards Institute**)

Acronym for the American National Standards Institute, an association of industry representatives that develops technical standards (including safety standards). These standards comprise a consensus from a variety of industries on good practice and design. ANSI standards relevant to application of safety products include the ANSI B11 Series, and ANSI/RIA R15.06. See [Standards and Regulations](#) on page 59.

Auto Power-Up

A safety light screen system feature that enables the system to be powered up into Run mode (or recover from a power interruption) without requiring a manual reset.

B

Blanking

A programmable feature of a safety light screen system which allows the light screen to ignore certain objects located within the defined area. See [Floating Blanking](#) and [Reduced Resolution](#).

Blocked **Condition**

A condition that occurs when an opaque object of sufficient size blocks/interrupts one or more light screen beams. When a blocked condition occurs, OSSD1 and OSSD2 outputs simultaneously turn off within the system response time.

Brake

A mechanism for stopping, slowing, or preventing motion.

C

Cascade

Series connection (or "daisy-chaining") of multiple emitters and receivers.

CE

Abbreviation for "Conformité Européenne" (French translation of "European Conformity"). The CE mark on a product or machine establishes its compliance with all relevant European Union (EU) Directives and the associated safety standards.

Clutch

A mechanism that, when engaged, transmits torque to impart motion from a driving member to a driven member.

Control Reliability

A method of ensuring the performance integrity of a control system or device. Control circuits are designed and constructed so that a single failure or fault within the system does not prevent the normal stopping action from being applied to the machine when required, or does not create unintended machine action, but does prevent initiation of successive machine action until the failure is corrected.

CSA

Abbreviation for Canadian Standards Association, a testing agency similar to Underwriters Laboratories, Inc. (UL) in the United States. A CSA-certified product has been type-tested and approved by the Canadian Standards Association as meeting electrical and safety codes.

D

Defined Area

The "screen of light" generated by a safety light screen system, defined by the height and the safety distance (minimum distance) of the emitter and receiver. When the defined area is interrupted by an opaque object of a specified cross section, a Trip or Latch condition results.

Designated Person

A person or persons identified and designated in writing, by the employer, as being appropriately trained and qualified to perform a specified checkout procedure.

E

Emitter

The light-emitting component of a safety light screen system, consisting of a row of synchronized modulated LEDs. The emitter, together with the receiver (placed opposite), creates a "screen of light" called the defined area.

External Device Monitoring (EDM)

A means by which a safety device (such as a safety light screen) actively monitors the state (or status) of external devices that may be controlled by the safety device. A lockout of the safety device will result if an unsafe state is detected in the external device. External device(s) may include, but are not limited to: MPCEs, captive contact relays/contactors, and safety modules.

F

Failure to Danger

A failure which delays or prevents a machine safety system from arresting dangerous machine motion, thereby increasing risk to personnel.

Final Switching Device (FSD)

The component of the machine's safety-related control system that interrupts the circuit to the machine primary control element (MPCE) when the output signal switching device (OSSD) goes to the OFF-state.

Fixed Blanking

A programming feature that allows a safety light screen system to ignore objects (such as brackets or fixtures) which will always be present at a specific location within the defined area. The presence of these objects will not cause the system's safety outputs (for example, Final Switching Devices) to trip or latch. If any fixed objects are moved within or removed from the defined area, a Lockout condition results.

Floating Blanking

See *Reduced Resolution*.

FMEA (Failure Mode and Effects Analysis)

A testing procedure by which potential failure modes in a system are analyzed to determine their results or effects on the system. Component failure modes that produce either no effect or a Lockout condition are permitted; failures which cause an unsafe condition (a failure to danger) are not. Banner safety products are extensively FMEA tested.

G

Guarded Machine

The machine whose point of operation is guarded by the safety system.

H

Hard (Fixed) Guard

Screens, bars, or other mechanical barriers affixed to the frame of the machine intended to prevent entry by personnel into the hazardous area(s) of a machine, while allowing the point of operation to be viewed. The maximum size of the openings is determined by the applicable standard, such as Table O-10 of OSHA 29CFR1910.217, also called a "fixed barrier guard."

Harm

Physical injury or damage to the health of people, which may result through direct interaction with the machine or through indirect means, as a result of damage to property or to the environment.

Hazard Point

The closest reachable point of the hazardous area.

Hazardous Area

An area that poses an immediate or impending physical hazard.

I

Internal Lockout

A Lockout condition that is due to an internal safety system problem. Generally, indicated by the red Status indicator LED (only) flashing. Requires the attention of a Qualified Person.

K

Key Reset (Manual Reset)

A key-operated switch used to reset a safety light screen system to Run mode following a Lockout condition, or to enable machine operation following a Latch condition. Also refers to the act of using the switch.

L

Latch Condition

The response of the safety light screen safety outputs (for example, OSSDs) when an object equal to or greater than the diameter of the specified test piece enters the defined area. In a Latch condition, safety outputs simultaneously de-energize and open their contacts. The contacts are held (latched) open until the object is removed from the defined area and a manual reset is performed. A latching output is used most often in perimeter guarding applications. (See Trip Condition.)

Lockout Condition

A safety light screen condition that is automatically attained in response to certain failure signals (an internal lockout). When a Lockout condition occurs, the safety light screen's safety outputs turn Off; the failure must be corrected and a manual reset is required to return the system to Run mode.

M

Machine Primary Control Element (MPCE)

An electrically powered element, external to the safety system, which directly controls the machine's normal operating motion in such a way that the element is last (in time) to operate when machine motion is either initiated or arrested.

Machine Response Time

The time between the activation of a machine stopping device and the instant when the dangerous parts of the machine reach a safe state by being brought to rest.

Minimum Object Sensitivity (MOS)

The minimum-diameter object that a safety light screen system can reliably detect. Objects of this diameter or greater will be detected anywhere in the defined area. A smaller object can pass undetected through the light if it passes exactly midway between two adjacent light beams. Also known as MODS (Minimum Object Detection Size). See also Specified Test Piece.

Muting

The automatic suspension of the safeguarding function of a safety device during a non-hazardous portion of the machine cycle.

O

Off State

The state in which the output circuit is interrupted and does not permit the flow of current.

On State

The state in which the output circuit is complete and permits the flow of current.

OSHA (Occupational Safety and Health Administration)

A U.S. Federal agency, Division of the U.S. Department of Labor, that is responsible for the regulation of workplace safety.

OSSD

Output Signal Switching Device. The safety outputs that are used to initiate a stop signal.

P

Part-Revolution Clutch

A type of clutch that may be engaged or disengaged during the machine cycle. Part-revolution clutched machines use a clutch/brake mechanism, which can arrest machine motion at any point in the stroke or cycle.

Pass-Through Hazard

A pass-through hazard is associated with applications where personnel may pass through a safeguard (which issues a stop command to remove the hazard), and then continues into the guarded area, such as in perimeter guarding. Subsequently, their presence is no longer detected, and the related danger becomes the unexpected start or restart of the machine while personnel are within the guarded area.

Point of Operation

The location of a machine where material or a workpiece is positioned and a machine function is performed upon it.

PSDI (Presence-Sensing Device Initiation)

An application in which a presence-sensing device is used to actually start the cycle of a machine. In a typical situation, an operator manually positions a part in the machine for the operation. When the operator moves out of the danger area, the presence sensing device starts the machine (no start switch is used). The machine cycle runs to completion, and the operator can then insert a new part and start another cycle. The presence sensing device continually guards the machine. Single-break mode is used when the part is automatically ejected after the machine operation. Double-break mode is used when the part is both inserted (to begin the operation) and removed (after the operation) by the operator. PSDI is commonly confused with "Trip Initiate." PSDI is defined in OSHA CFR1910.217. Banner safety light screen systems may not be used as PSDI devices on mechanical power presses, per OSHA regulation 29 CFR 1910.217.

Q

Qualified Person

A person who, by possession of a recognized degree or certificate of professional training, or who, by extensive knowledge, training and experience, has successfully demonstrated the ability to solve problems relating to the subject matter and work.

R

Receiver

The light-receiving component of a safety light screen system, consisting of a row of synchronized phototransistors. The receiver, together with the emitter (placed opposite), creates a "screen of light" called the defined area.

Reduced Resolution

A feature that allows a safety light screen system to be configured to produce an intentionally disabled light beam(s) within the light screen, which increases the minimum object sensitivity. The disabled beam(s) appears to move up and down ("float") in order to allow the feeding of an object through the defined area at any point without tripping the safety outputs (for example, OSSDs) and causing a Trip or Latch condition. Sometimes called "Floating Blanking."

Reset

The use of a manually operated switch to restore the safety outputs to the On state from a lockout or a Latch condition.

Resolution

See *Minimum Object Sensitivity*

S

Self-Checking (Circuitry)

A circuit with the capability to electronically verify that all of its own critical circuit components, along with their redundant backups, are operating properly. Banner safety light screen systems and safety modules are self-checking.

Separation Distance (Safety Light Screen)

The minimum distance required to allow the machine's hazardous motion to stop completely, before a hand (or other object) can reach the nearest hazard point. Measured from the midpoint of the defined area to the nearest hazard point. Factors that influence minimum separation distance include the machine stop time, the light screen system response time, and the light screen minimum object detection size.

Specified Test Piece

An opaque object of sufficient size used to block a light beam to test the operation of a safety light screen system. When inserted into any part of the defined area, it will place a system into a Trip or Latch condition. Banner supplies specified test pieces with each system. See also *Minimum Object Sensitivity*.

Supplemental Guarding

Additional safeguarding device(s) or hard guarding, used to prevent a person from reaching over, under, through or around the primary safeguard or otherwise accessing the guarded hazard.

T

Test Piece

An opaque object of sufficient size used to block a light beam to test the operation of a safety light screen system.

Trip Condition

The response of the safety outputs (for example, OSSDs) of a safety light screen system when an object equal to or greater than the diameter of the specified test piece enters the defined area. In a Trip condition, the OSSDs simultaneously de-energize. A Trip condition clears (resets) automatically when the object is removed from the defined area. (See *Latch Condition*.)

Trip Initiate

The resetting of a safeguard causing the initiation of machine motion or operation. Trip Initiate is not allowed as a means to initiate a machine cycle per NFPA 79 and ISO 60204-1, and is commonly confused with PSDI.

U

UL (Underwriters Laboratory)

A third-party organization that tests products for compliance with appropriate standards, electrical codes, and safety codes. Compliance is indicated by the UL listing mark on the product.

Index

I

initial power-up 28

L

LEDs

emitter 38

receiver 38

light-emitting diodes 38

See also LEDs