

# Global Network

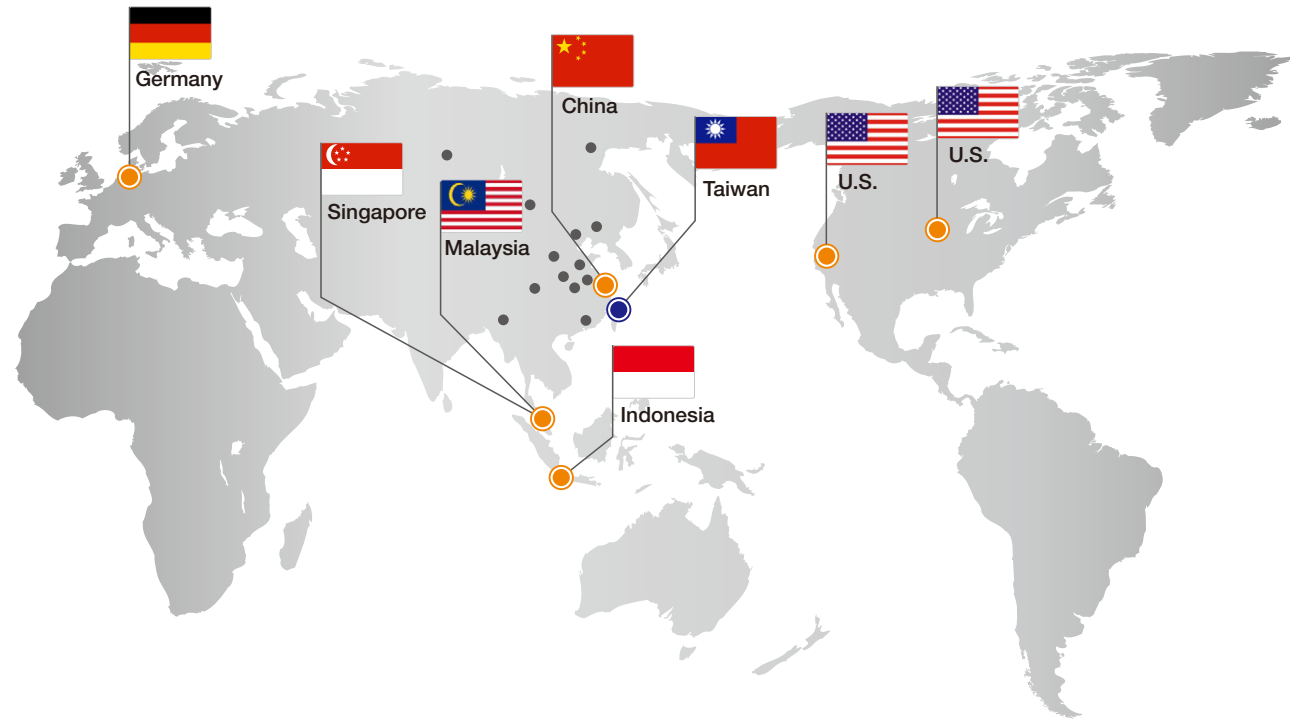

## Asia

- Taiwan**  
**FineTek Co., Ltd. - Taipei Head Quarter**  
 No.16, Tzuchiang St., Tucheng Industrial Park  
 New Taipei City 236, Taiwan  
 TEL: 886-2-2269-6789  
 FAX: 886-2-2268-6682  
 EMAIL: info@fine-tek.com
- China**  
**Fine automation Co., Ltd. - Shanghai Factory**  
 No.451 DuHui Rd, MinHang District, Shanghai,  
 China 201109  
 TEL: 86-21-6490-7260  
 EMAIL: info.sh@fine-tek.com
- Singapore**  
**FineTek Pte Ltd. - Singapore Office**  
 No. 60 Kaki Bukit Place, #07-06 Eunos  
 Techpark 2 Lobby B, Singapore 415979  
 TEL: 65-6452-6340  
 EMAIL: info.sg@fine-tek.com
- Indonesia**  
**FineTek Co., Ltd. - Indonesia Office**  
 Ruko Golden 8 Blok H No.40  
 Gading Serpong, Tangerang, Indonesia  
 TEL: 62 (021)-2923-1688  
 EMAIL: info.id@fine-tek.com
- Malaysia**  
**FineTek Co., Ltd. - Malaysia Office**  
 8-05, Plaza Azalea, Persiaran Bandaraya,  
 Seksyen 14, 40000 Shah Alam, Selangor, Malaysia  
 TEL: 603-5524-7168  
 EMAIL: info.my@fine-tek.com

## North America

- California, U.S.**  
**Aplus Finetek Sensor Inc. - US Office**  
 355 S. Lemon Ave, Suite D, Walnut,  
 CA 91789  
 TEL: 1 909 598 2488  
 FAX: 1 909 598 3188  
 EMAIL: info@aplusfine.com
- Illinois, U.S.**  
**Aplus Finetek Sensor Inc.**  
 TEL: 1 815 632-3132  
 FAX: 1 815 716 8464  
 EMAIL: info@aplusfine.com

## Europe

- Germany**  
**FineTeK GmbH - Germany Office**  
 Frankfurter Str. 62, OG D-65428  
 Ruesselsheim, Germany  
 TEL: +49-(0)6142-17608-0  
 FAX: +49-(0)6142-17608-20  
 EMAIL: info@fine-tek.de



Distributor:

08-EST-B3-EP, 04/27/2017



## EST Grain Silo Temperature & Level Monitoring System



www.fine-tek.com

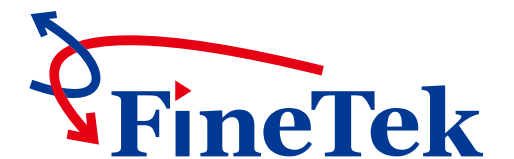



# System Introduction



Temperature is a key factor for maintaining grain quality in a grain storage system. When the grain has suffered from deterioration, corrosion or pest and disease damage, the temperature is increased inevitably. If precise temperature information of the grain can be mastered, an air conditioning system can be more efficiently controlled to achieve high efficient energy management. For silo management, an EST system can measure grain temperature in silo and measure stored grain level synchronously, thereby not only instantly tracking and recording grain conditions, recording historical records, but also providing optimal grain storage quality monitoring.

The EST can be matched with the HubLink hub series, and employs an RS485 communication interface to transmit information to a central control room or a human-machine interface via wire or wirelessly. The EST is matched with MMS-TLA silo information and integrated with monitoring software, so that a user can easily monitor dual information, both the temperature and grain level in the silo, through a remote computer, thereby performing grain storage management with the utmost convenience and efficiency.

## Content

System Architecture	3
EST110 multi-point temperature sensor	5
EST120 2 in 1 grain temperature & level monitoring transmitter	7
MMS-TLA Materials Management System	9
IPC Industrial Computer	11
HubLink 1-wire / HubLink RS485	13
Wireless System Architecture	15
Application Example	17
System Selection Guide	21
RCU2 Remote Control Unit	23
Order Information	25



# System Architecture



## Wireless System

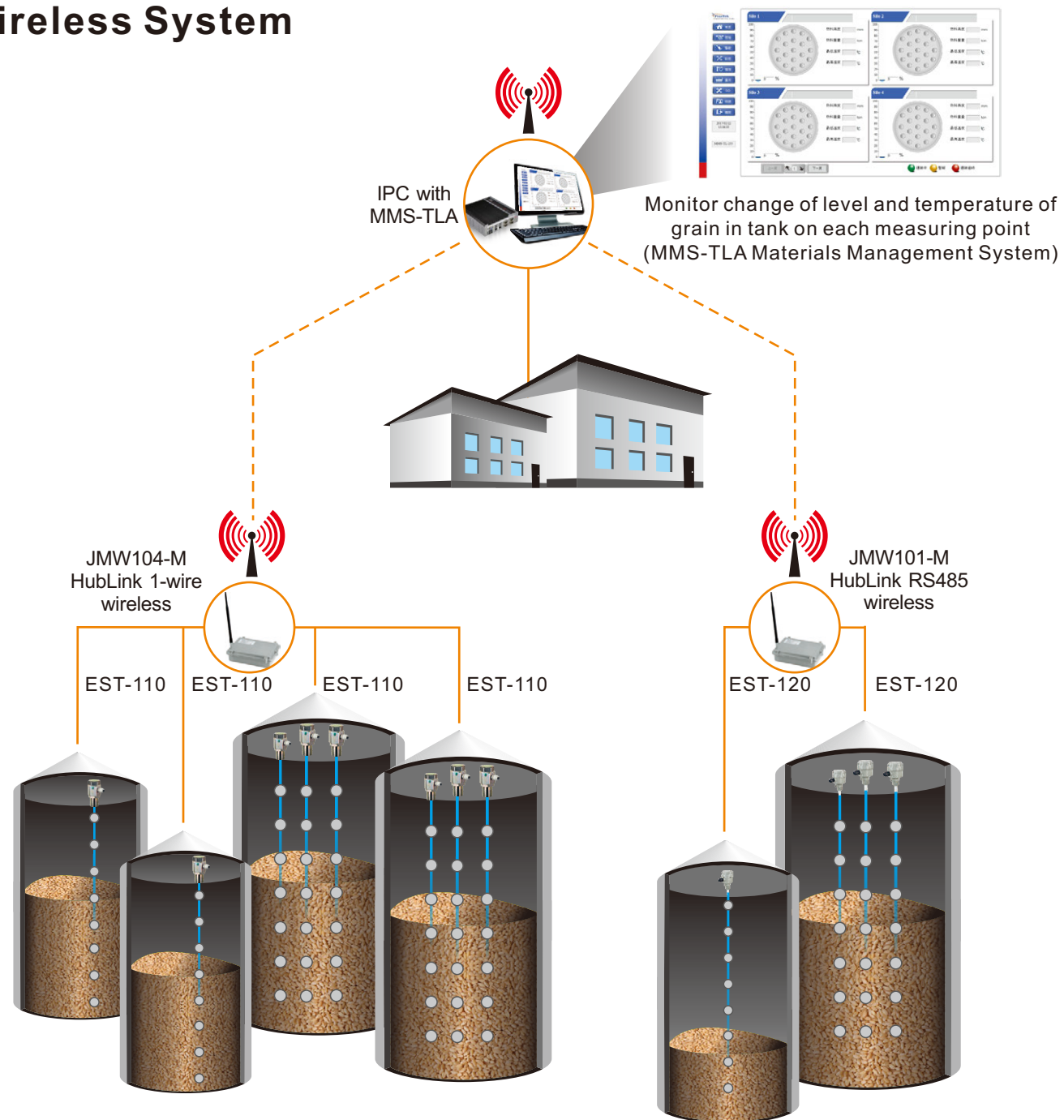

(Wireless system, please refer P15 for more details)

## Wired System

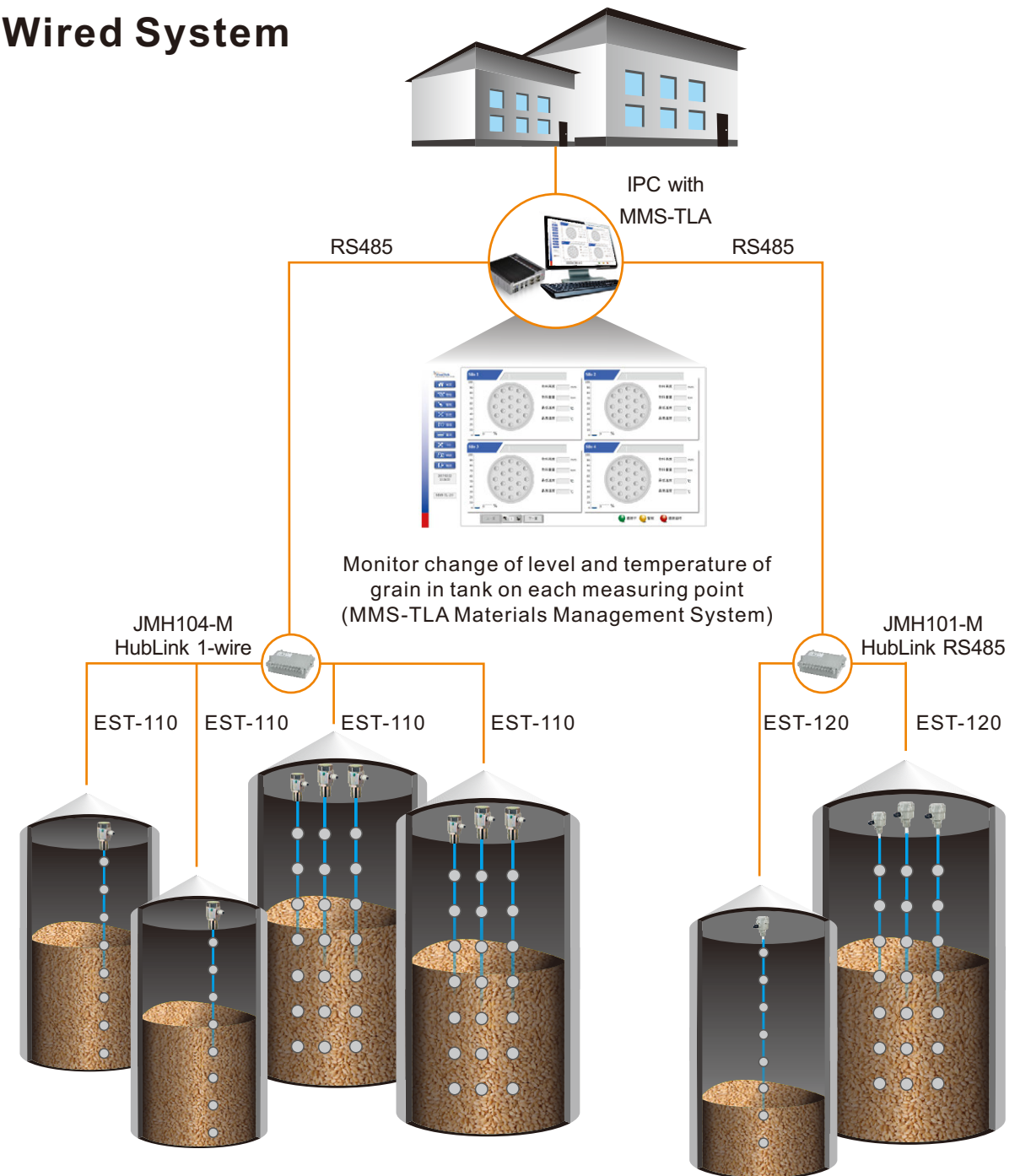



# EST110

## multi-point temperature sensor

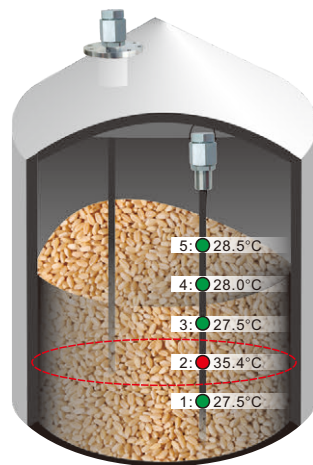

### System Introduction

EST110 multi-point temperature sensor wire can measure temperature of grain in different positions of the silo in real time, to record condition of the grain and provide you the optimal monitoring of grain storage quality. Relative to the traditional silo, manual temperature measurement is time-consuming and arduous. The temperature measured by EST110 is digital signal, which can output RS485 communication mode through matching with HubLink 1-wire to transmit information to the central control room or human-machine interface. The user can easily know the grain temperature in the silo only from the remote end and conduct the most efficient grain storage management.

### Features

- Reinforced steel cable design can effectively resist the impact of grain and prolong service life of the product.
- Provide multi-point temperature measurement to help managers cope with food more swiftly.
- Detect whether there is fungus produced or activities of insects, to maintain food quality.
- Provide real-time monitoring of silo temperature for practitioners in food, fodder and grain, to help long-term storage.
- Prevent qualitative change of grain in the silo and fire disaster due to smolder.
- Temperature measurement position can be customized according to customer's requirements, which can be hung outside or built in the silo.

### Specifications

Measurement range	-10~85°C
Resolution	0.1 °C
Accuracy	± 0.5 °C
LengthMax.	Max. 30 m
Quantity of sensors	Max. 30 PCS
Position of sensors	One sensor is built in every meter
Cable material	Coated with PVC, inner ring is copper wire (Standard)
Tensile load	PVC: 3000 Kgf, PE: 4000 Kgf
IP rating	IP67
Housing Material	SS41 Low-carbon steel
Outgoing cable diameter	φ4~8mm

Hublink 1-wire is requirement (combination)

### Dimension

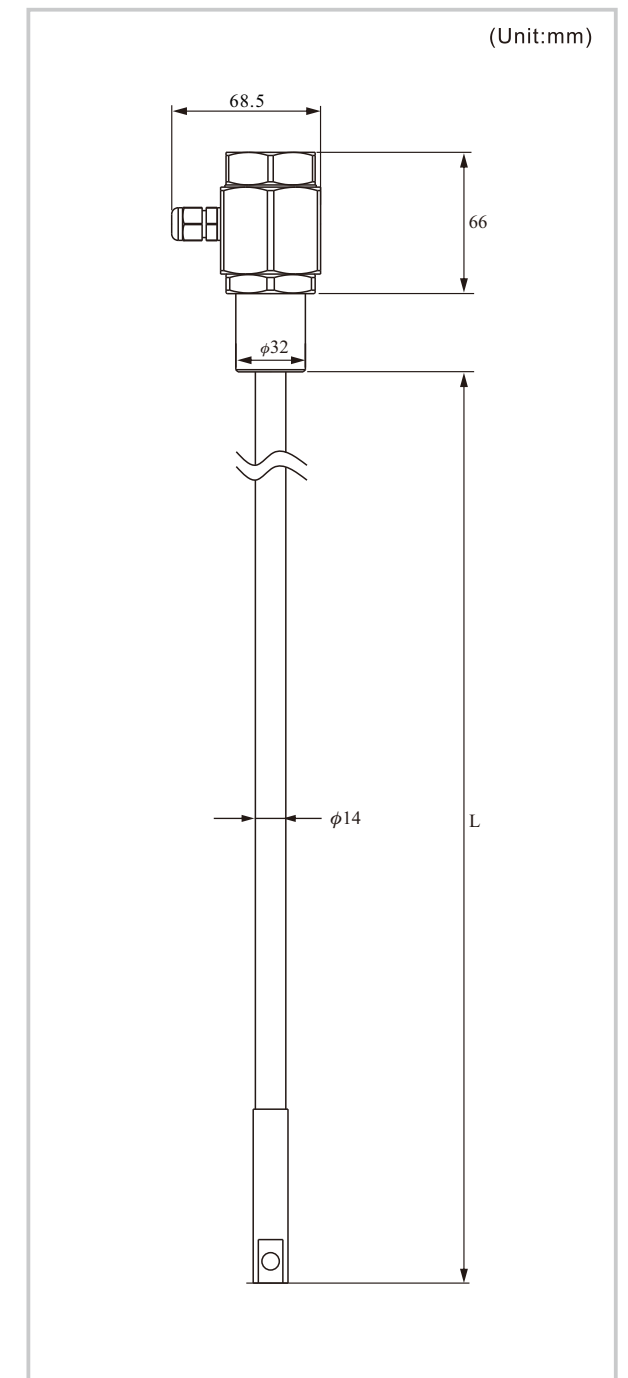

# EST120 2 in 1 grain temperature & level monitoring transmitter

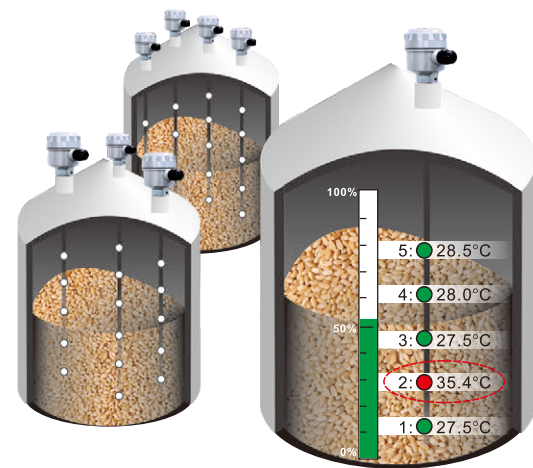

## Introduction

For silo management, users must install temperature sensing wire and grain level sensor separately in the past to get the information of temperature and grain level. EST120 two-in-one silo temperature and grain level meter can synchronously measure grain temperature and level in the silo, to track and record grain condition, so as to provide you the optimal grain storage quality monitoring. EST120 adopts the RS485 communication interface, to transmit information to the central control room or human-machine interface. Users can monitor dual information of grain temperature and level in the silo from the far end, to conduct the most convenient and efficient grain storage management.

## Features

- Unique in the industry, EST120 transmitter integrated with simultaneous monitoring of grain level and temperature.
- Steel cable design can effectively resist the impact of grain and prolong service life of the product.
- Provide real-time multipoint temperature measurement to help managers cope with food more swiftly.
- Detect whether there is fungus produced or there are activities of insects, to maintain food quality and facilitate long-term storage.
- Prevent qualitative change of grain in the silo and fire disaster due to smolder.
- Temperature measurement can be customized according to customer's requirements.
- Any two points of EST120 are in simple calibration mode of grain level.
- The product uses open main current communication interface RS485. The system user can install the device on any system having the communication interface.

## Specifications

Power input	9 ~ 30 Vdc
Measurement range	-10~85 °C
Resolution	0.1 °C
Accuracy	± 0.5 °C
Length	Max.30 m
Quantity of sensors	Max.30 PCS
Position of sensor	Resolution
Sampling speed	Grain level measurement: ≤1sec Temperature measurement: ≤1sec/node
Non-linearity of grain level	± 1 % FS
Output interface	RS485; Baud Rate:9600~57600 bps
Material of junction box	Aluminum alloy (ADC-12)
Outgoing cable diameter	φ5.5~11.2 mm
Cable material	Coated with PVC, inner ring is copper wire
Tensile load	PVC: 3000 Kgf, PE: 4000 Kgf
IP rating	IP 67

## Dimension

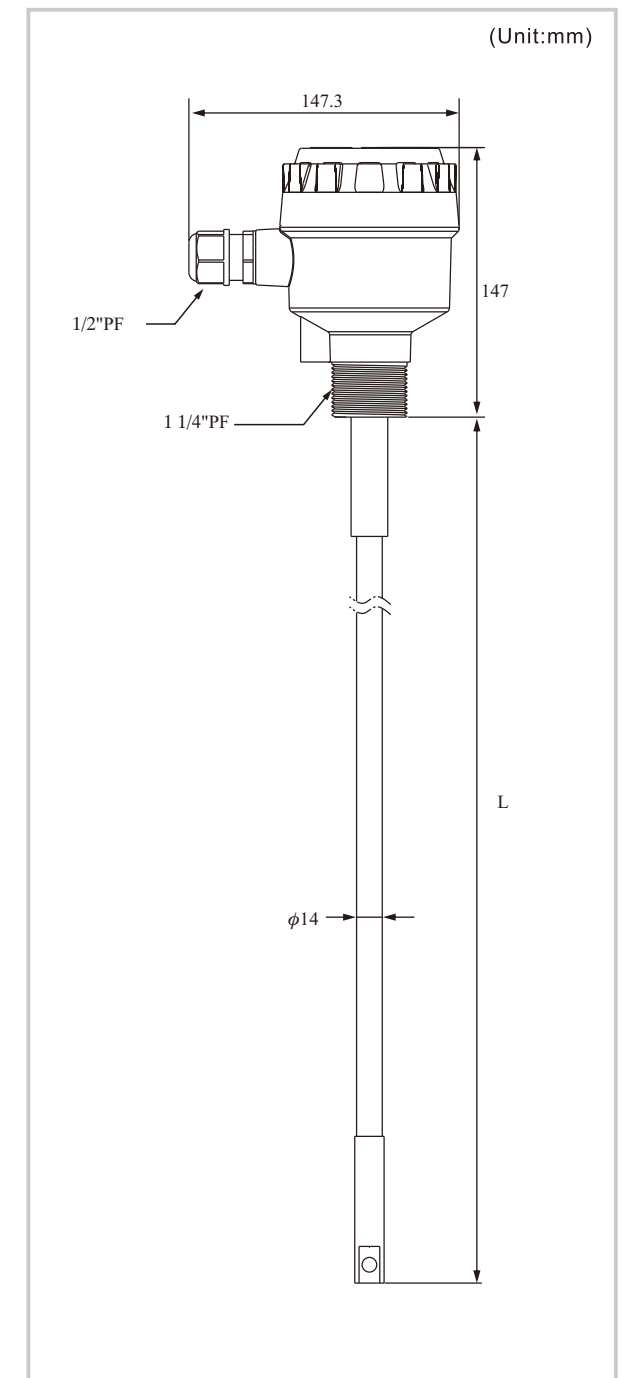



# MMS-TLA Materials Management System



## Software (MMS-TLA)



### System Requirements

- Central processing unit (CPU) P4 1GHz above
- Memory RAM 512MB above
- Operating system Microsoft Windows 2000 above
- At least 1GB idle hardware space for database
- RS232 or USB

### Introduction

MMS-TLA intelligent grain silo temperature and level management system is a set of PC software, which can replace measurement and record manually and operating method is through configuration of electricity meter and switch. It can be widely applied to industries such as rice milling, flour, fodder, food, low temperature unhulled rice and grain crop as well as grain level environment that needs measurement of multi-point temperature. It is applicable to temperature and grain level detection in tank and barrel of general power, particle and block. MMS-TLA can monitor temperature change of the silo all the time, to prevent abnormal temperature, so as to avoid damage to the grain. It can also effectively manage entry, stock and sales of grain, to reduce operating cost, so as to increase profit and improve customers' competitiveness.

### Features

- Set Item: Tank number, tank name, device number, device model, HubLink 1-Wire general setting, grain high level alarm, grain low level alarm, high temperature alarm, low temperature alarm, series port setting, connection timeout setting, selection of multiple tank types and related parameters corresponding to sizes, alarm sending mode, alarm information receiving mode and account setting and SMTP email server setting, etc.
- Display Item: Tank name, grain percentage, grain weight, minimum temperature, maximum temperature, current temperature of each measuring point of a sensing device, temperature change of a certain sensing device's certain measuring point on that day and history information review, etc.
- Alarm Item: Grain high/low level alarm, high/low temperature alarm and connection timeout, etc.
- Report Output: History information is transformed to text or Excel format.
- Alarm Mode: Display it on the screen on the spot and utilize e-mail to transmit alarm information to preset receivers through regional Intranet or Internet.
- Account Setting: Set the account for rights of Supervisor or Operator.

### Home

User can view all information of each tank in page mode, including high/ low alarm, material height, ratio of remaining material, material weight, sensing weight status, material selection, tank measurement, and motor indication etc.

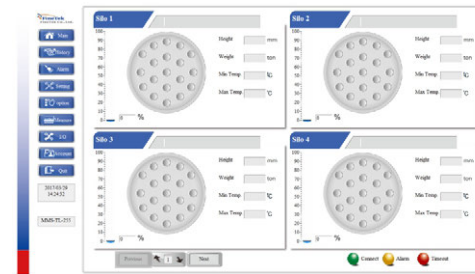

### History Chart

User can observe all historical messages and transfer data in .txt or EXCEL format standard, let user can analyze data in Windows system.

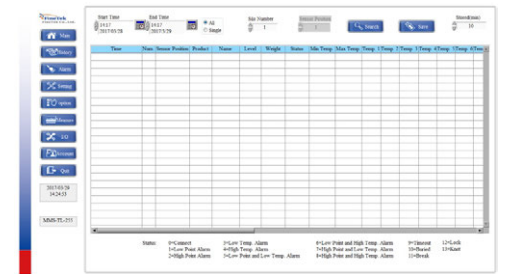

### Material Management

Daily information can be checked and examined the import /outport material time. Equips with automatic scaling function and mouse point sliding function, let user easy to find the critical point.

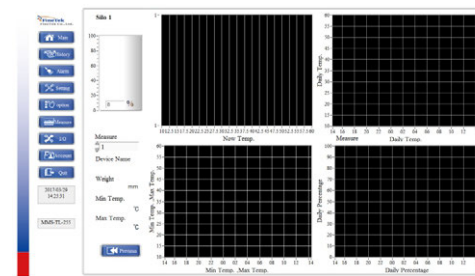

### Alarm Setting

This function supports user to get real-time message to predetermined mail message recipients and field operator get the alarm message dialog window at the same time. It save the communication between the field and manage center while the critical situation occurred.

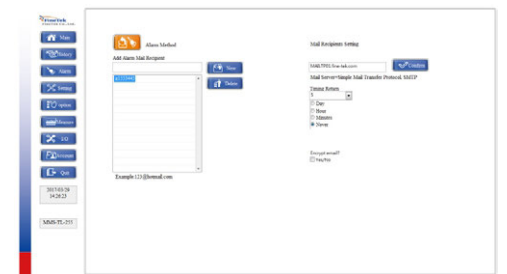

### I/O Setting

Relay output for level or temperature.

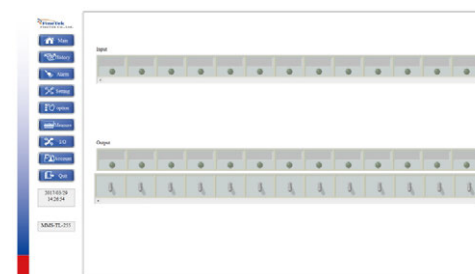

### Configuration

Can set parameters of each device, including: Silo number, Comport, Product, Type, Density etc.

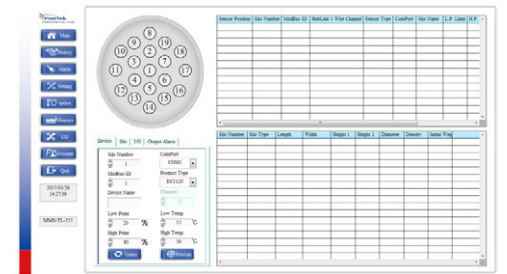



# IPC Industrial Computer



## IPC (Industrial PC)



### Features

- Intel® Dual Core D2550 1.86 GHz processor
- 8 COM model: 6 x RS-232, 2 x RS-232/422/485
- 6 x USB 2.0
- Dual PCIe GbE LAN for high-speed network applications

### Specifications

Model Name		TANK-600-D2550
Chassis	Color	Black C + Silver
	Dimensions (WxDxH)	193.4 x 200 x 57 mm
	System Fan	Fanless
	Chassis Construction	Aluminum alloy
Motherboard	CPU	Intel® D2550 1.86 GHz dual-core processor
	Chipset	Intel® NM10
	System Memory	On-board DDR3 4GB
Storage	Hard Drive	1 x 2.5" SATA HDD Bay
I/O interfaces	USB 2.0	6
	Ethernet	2 x RJ-45 Realtek 8111E GbE LAN
	RS-232	6 COM: 6 x DB-9 16 COM: 14 x RS-232 by DB-78
	RS-422/485	2 x RS-232/422/485 by DB-9
	Display	1 x VGA
	Resolution	VGA: Up to 2048 x 1536 @ 75Hz
	Audio	1 x Line-out, 1 x Mic-in
Expansions	PCIe Mini	1 x Full Size (Support mSATA) 1 x Half size
	Power Input	DC Jack : 9~36V DC
Power	Power Consumption	12V@2.2A (Intel® Atom™ D2550 with 4GB DDR3 memory)
	Mounting	VESA 100, DIN-Rail
Reliability	Operating Temperature	-20°C ~70°C with air flow (SSD), 5% ~ 95%, non-condensing
	Operating Shock	Half-sine wave shock 5G, 11ms, 3 shocks per axis
	Operating Vibration	MIL-STD-810F 514.5C-2 (with SSD)
	Weight (Net/Gross)	2.2 Kg / 3 Kg
	Safety / EMC	CE/FCC
OS	Supported OS	Microsoft® Windows®7

### Front View

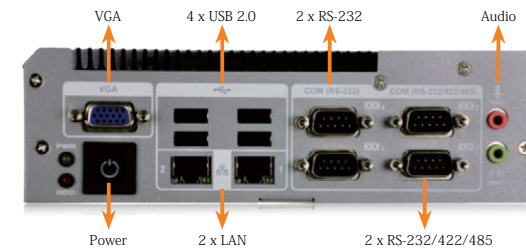

### Rear View

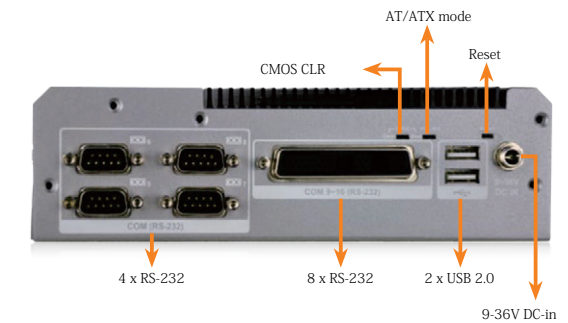

### Dimension

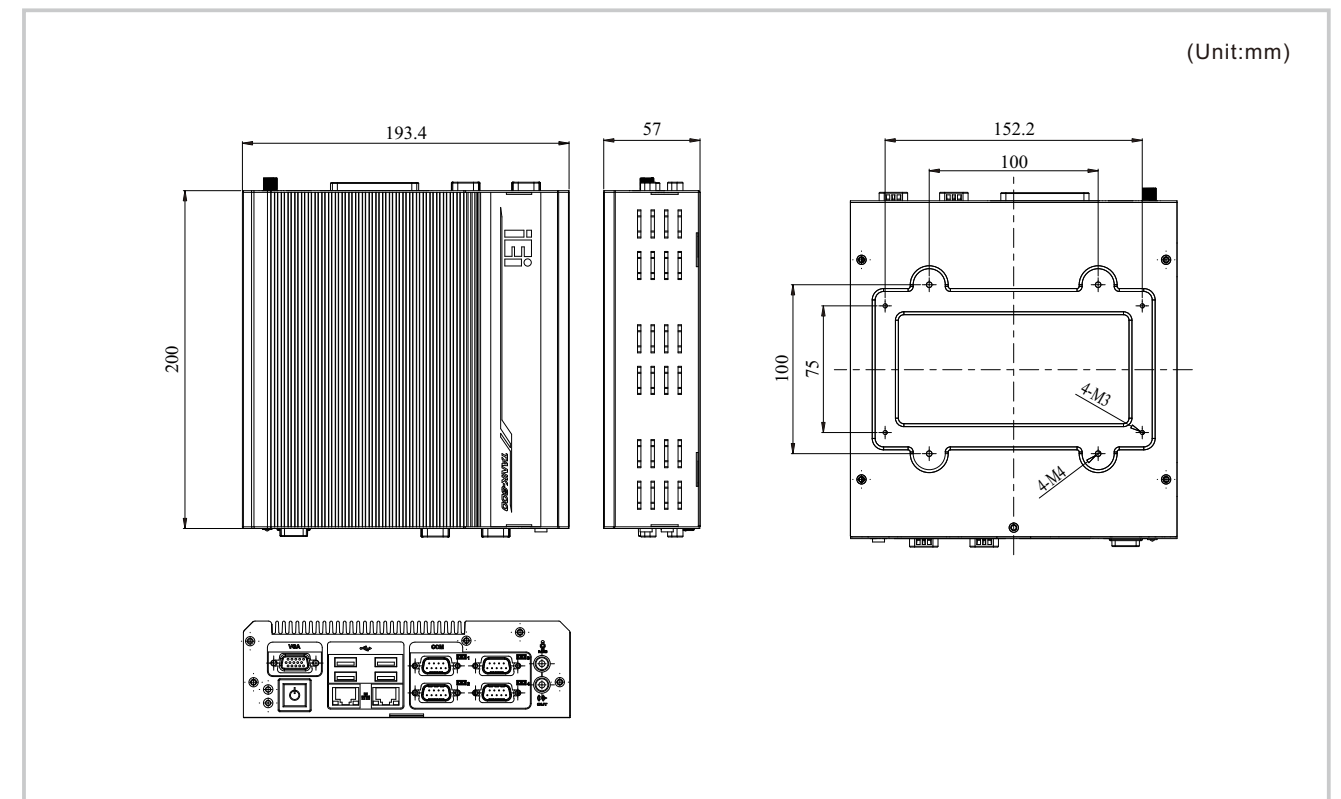

# HubLink 1-wire / HubLink RS485



## HubLink 1-wire

(Unit:mm)

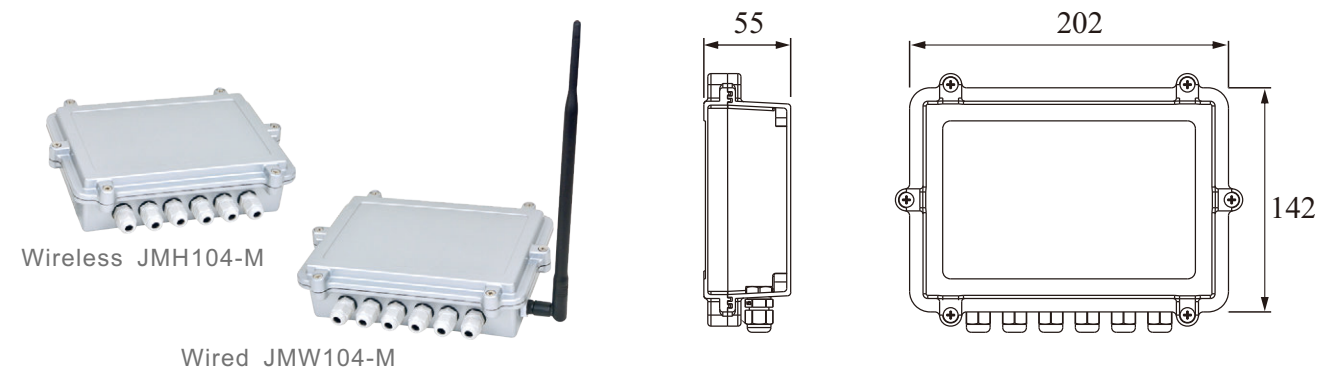

(combine with EST110 multi-point temperature sensor)

### Introduction

It extends and connects to the sensor through wired way, which can connect 4 sets of EST110 1-Wire communication modes. Each sensor has an independent connection, which can prevent the whole system from crashing due to a particular equipment failure, so as to make users capable of maintaining multiple equipment more easily. 1-wire digital signal can be transformed to RS485 to make MMS-TLA silo temperature and grain level management system or PLC read and use.

### Specifications

Supply voltage	10~30Vdc
Ambient temperature	-40~80°C
Connection port	Max.4
Housing	Aluminum alloy (ADC-12)
Communication interface	RS-485
RS-485 baud rate	9600~115200
IP rating	IP67

## HubLink RS485

(Unit:mm)

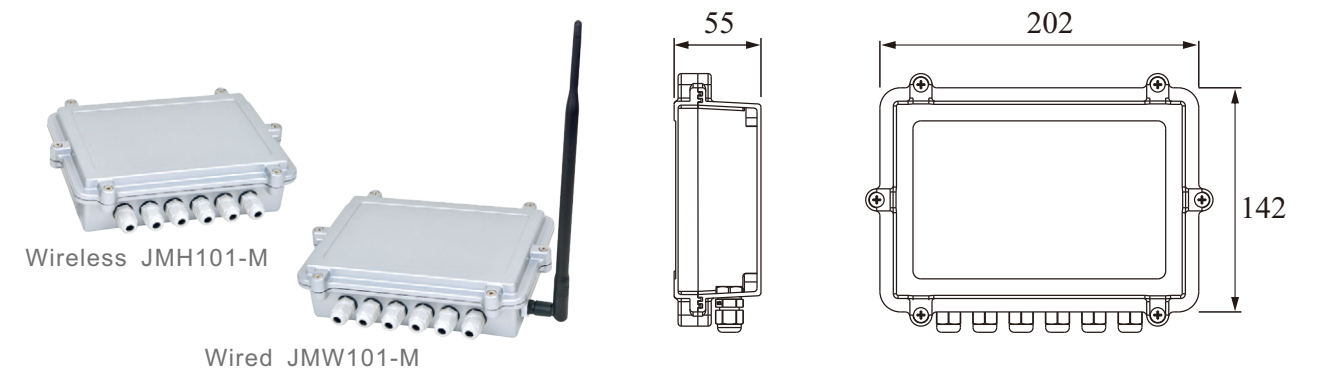

(combine with EST120 2 in 1 grain temperature & level monitoring transmitter)

### Introduction

It integrates 4 sets of signals with RS485 communication mode to make wiring more convenient and clear. Each port is independent, which can prevent the whole system from crashing due to a particular equipment failure, to make users capable of maintaining multiple equipments more easily. 4 sets of 4-wire type connection ports also supply 24VDC power for external device.

### Specifications

Power input	10~30Vdc
Current input	2A
Power output	10~30Vdc
Current output	400 mA / CH (under power input and current of 2A)
Output	RS-485
Input	Four sets of RS-485 (each set is independent and isolated)
Baud rate	1200~57600
Working temperature	-40~80°C
Electrostatic protection	IEC61000-4-2 ESD 8kV Air, 4kV contact
IP rating	IP67



# Wireless System Architecture

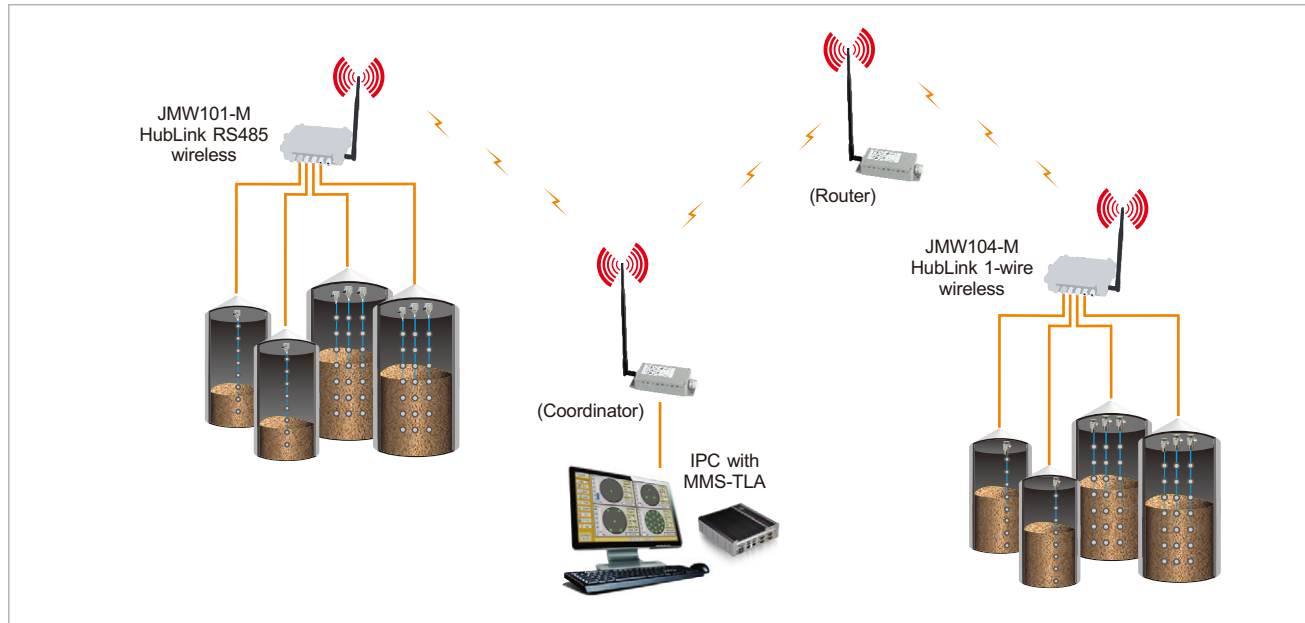

HubLink Wireless uses wireless to transmit RS485 signal, help customer reduce cable and maintenance costs.

## Coordinator / Router

### Coordinator

P/N: JMW10-CX

Coordinator receives signal from HubLink or Router, then sends to PC or PLC via RS485 interface, MMS software reads and displays the measured data

### Router

P/N: JMW10-RX

Router increases transmission distance when the wireless signal strength from Hublink to Coordinator is not strong enough due to long distance. Router receives data from HubLink, then enhance and forward signal to Coordinator. then enhance and forward signal to Coordinator.



### Specification

Output communication	RS485
Input communication	HubLink RS485: Rs485 HubLink 1-wire: 1-wire signal
RS-485 baud rate	9600/19200/38400 57600/115200
Storage temp.	-40~80°C
Operating temp.	-40~80°C
Static electricity protection	IEC61000-4-2 ESD 8kV Air 4kV contact
Power Input	10V~30V
IP rating	IP67

### Wireless Communication

Operating frequency Range	2405 MHz ~ 2480 MHz
Number of channels	16 CH
Channel spacing	5 MHz
Date transmission rate	250 kbps
Sensitivity	-100 dBm (PER ≤ 1%)
Transmission range	Max. 2Km

### Specification

RS-485 baud rate	9600/19200/38400 57600/115200
Storage temp.	-40~80°C
Operating temp.	-40~80°C
Static electricity protection	IEC61000-4-2 ESD 8kV Air 4kV contact
Dimension	146 X 66 X 30 mm
Power Input	10V~30V
IP rating	IP67

### Wireless Communication

Operating frequency Range	2405 MHz ~ 2480 MHz
Number of channels	16 CH
Channel spacing	5 MHz
Date transmission rate	250 kbps
Sensitivity	-100 dBm (PER ≤ 1%)
Transmission range	Max. 2Km
Antenna specification	3.5mm SMA Female



# Application Example



## Case 1: EST110

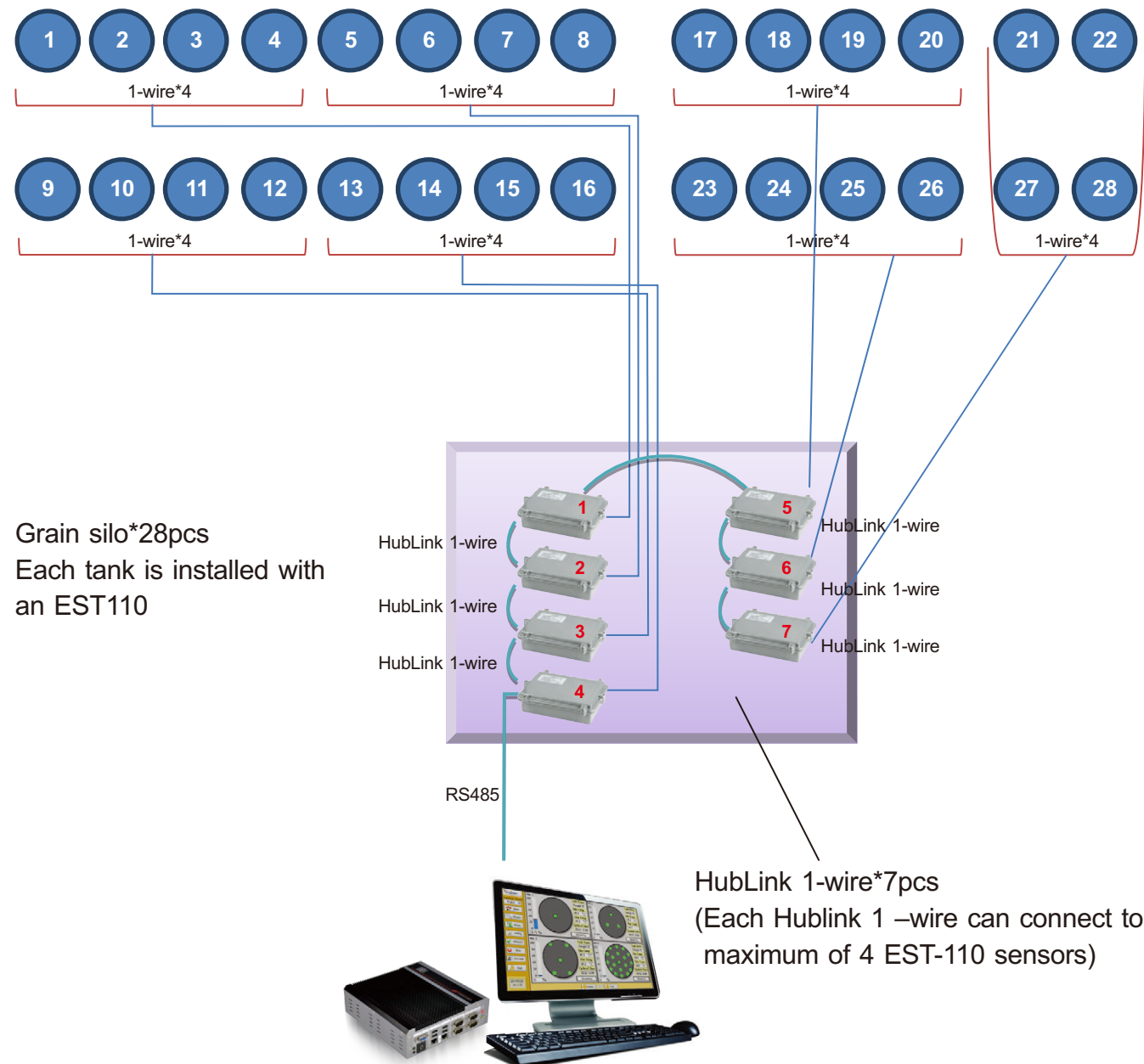

## Case 2: EST120

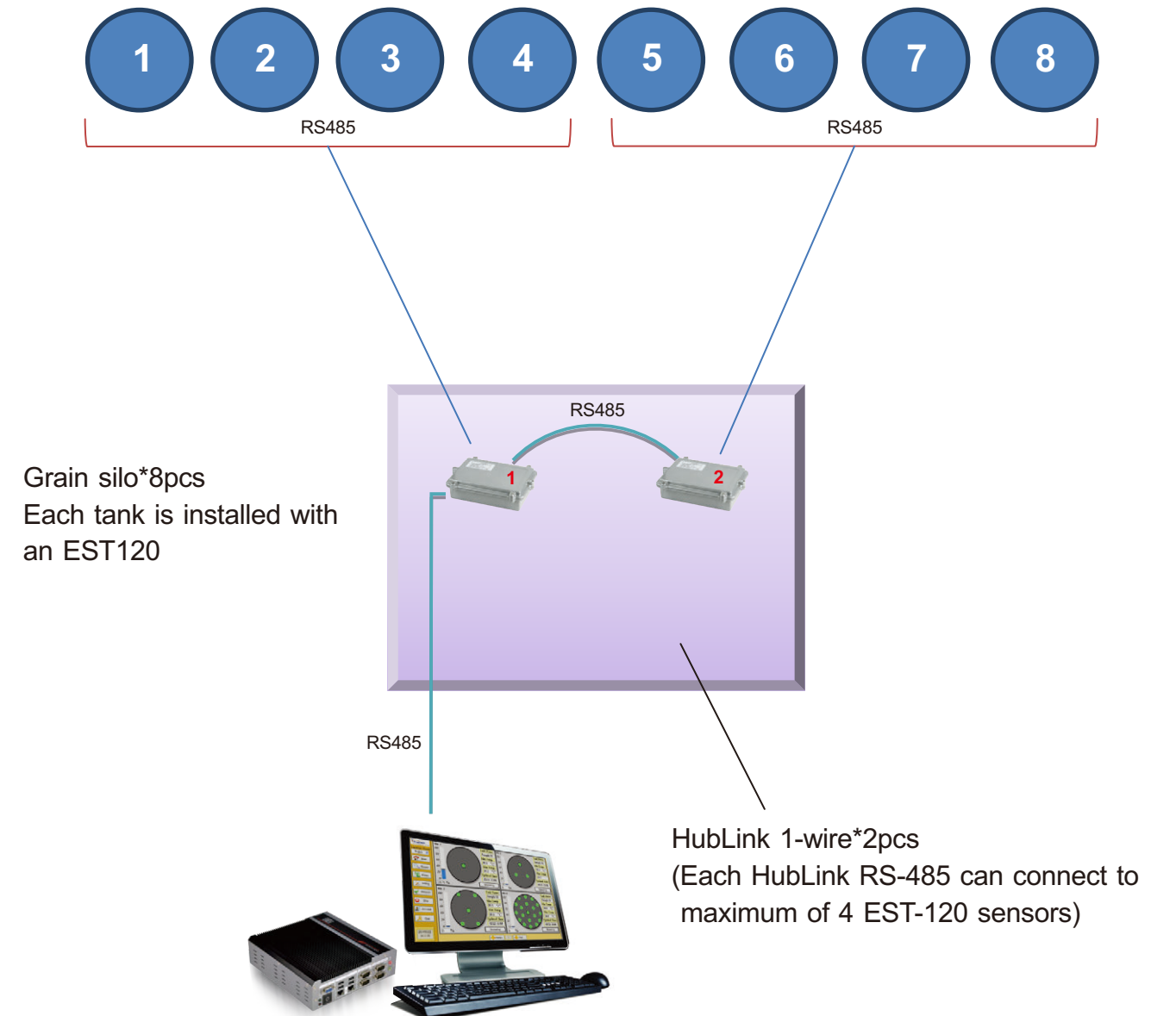



# Application Example

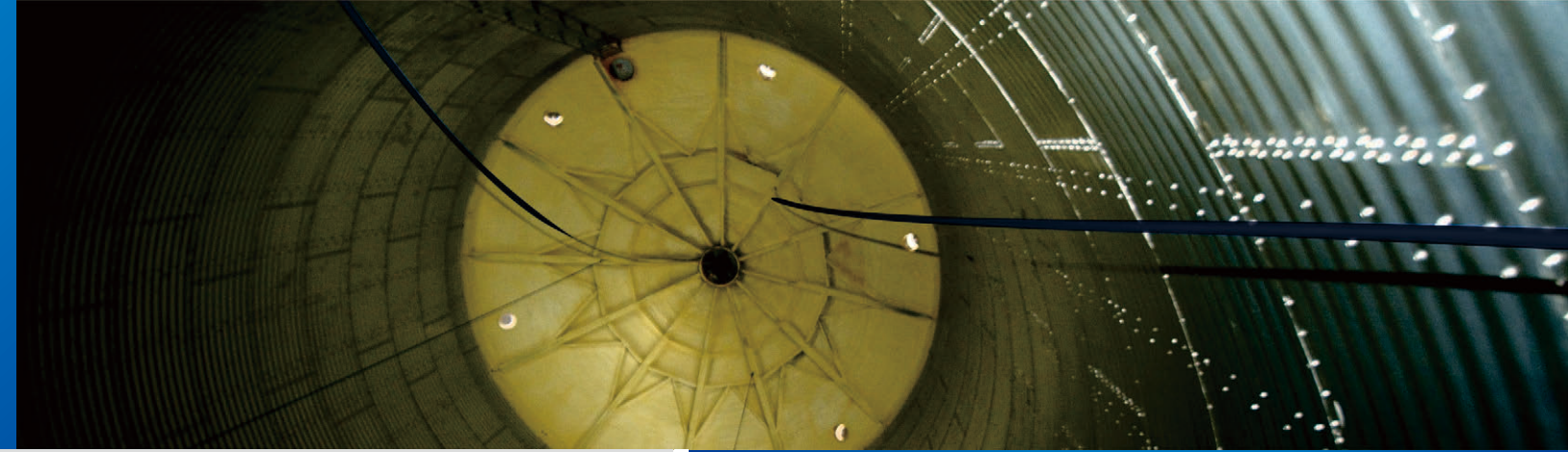

## Case 3: EST110+EST120

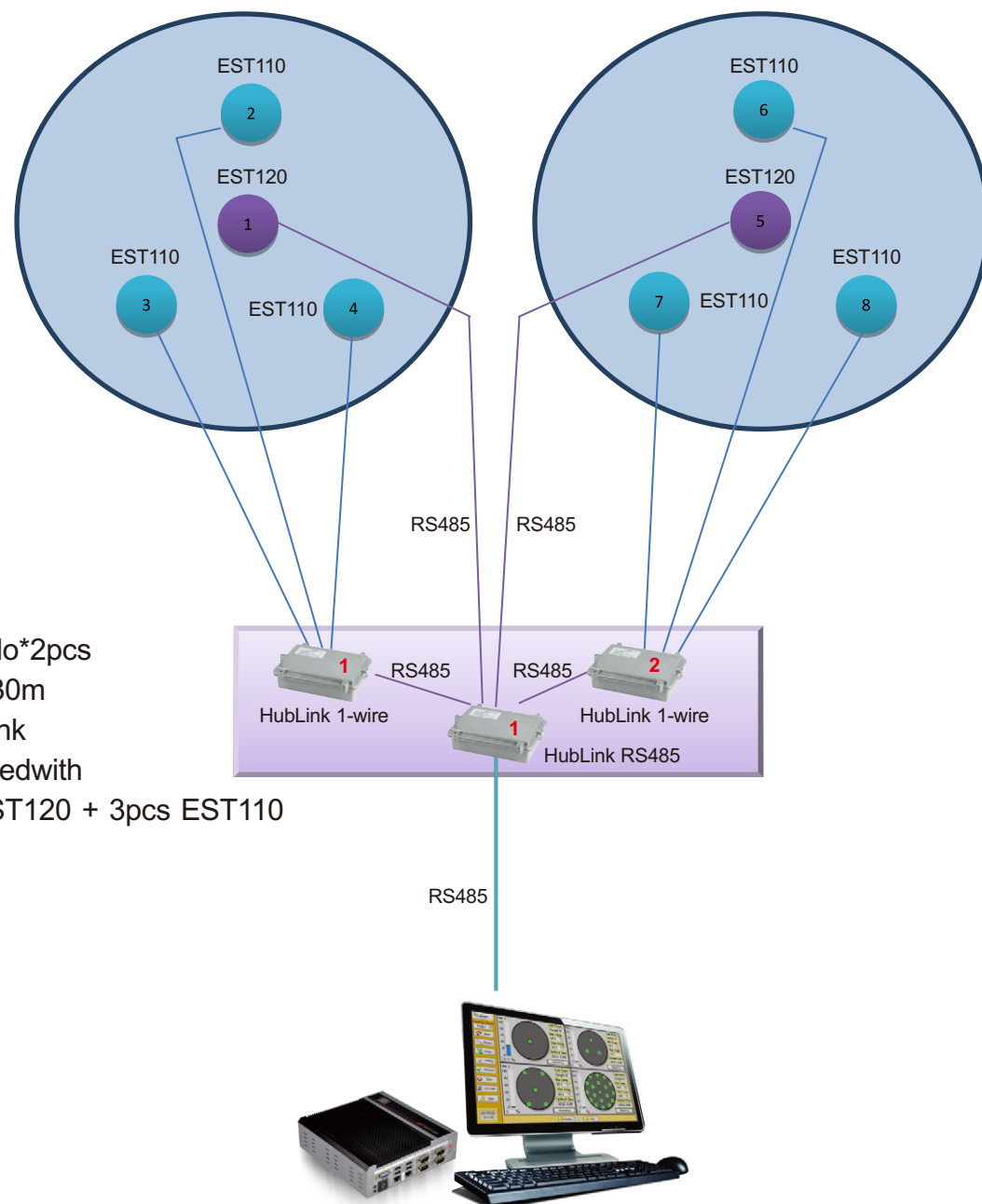

## Successful stories

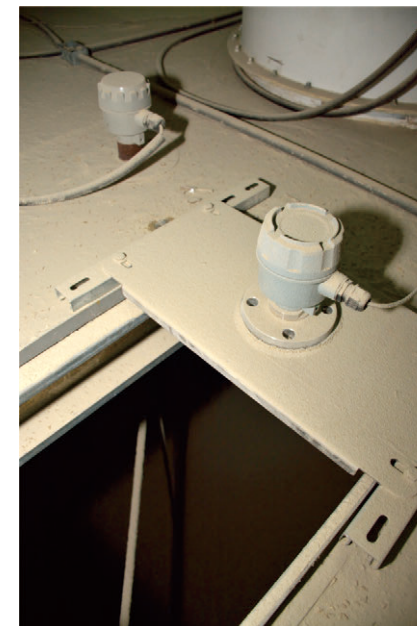

▲ EST120



▲ HubLink RS485



▲ HubLink 1-wire



▲ EST120



▲ EST110



# System Selection Guide

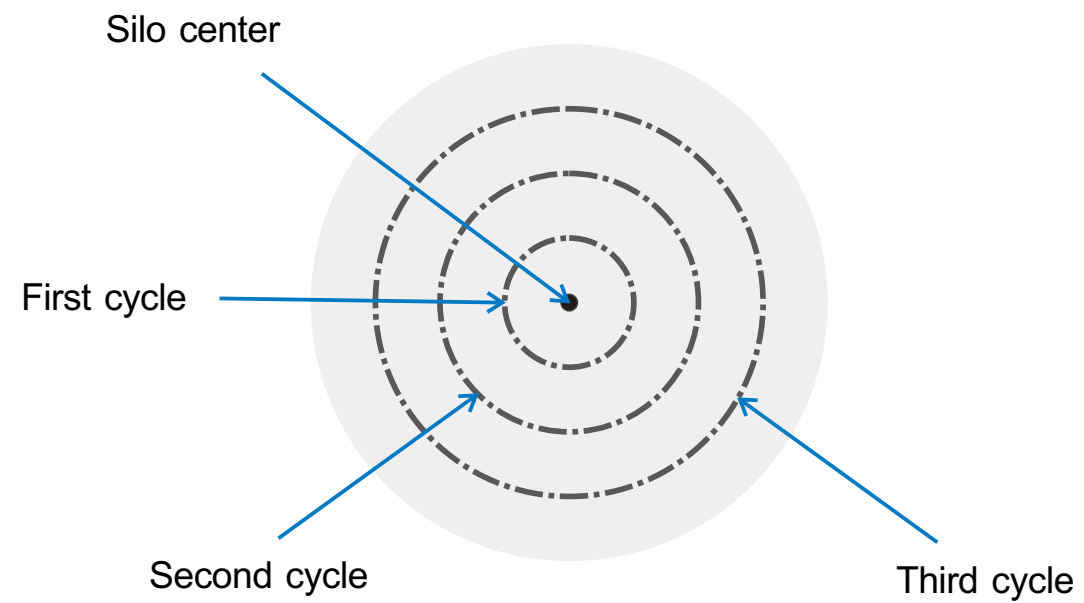
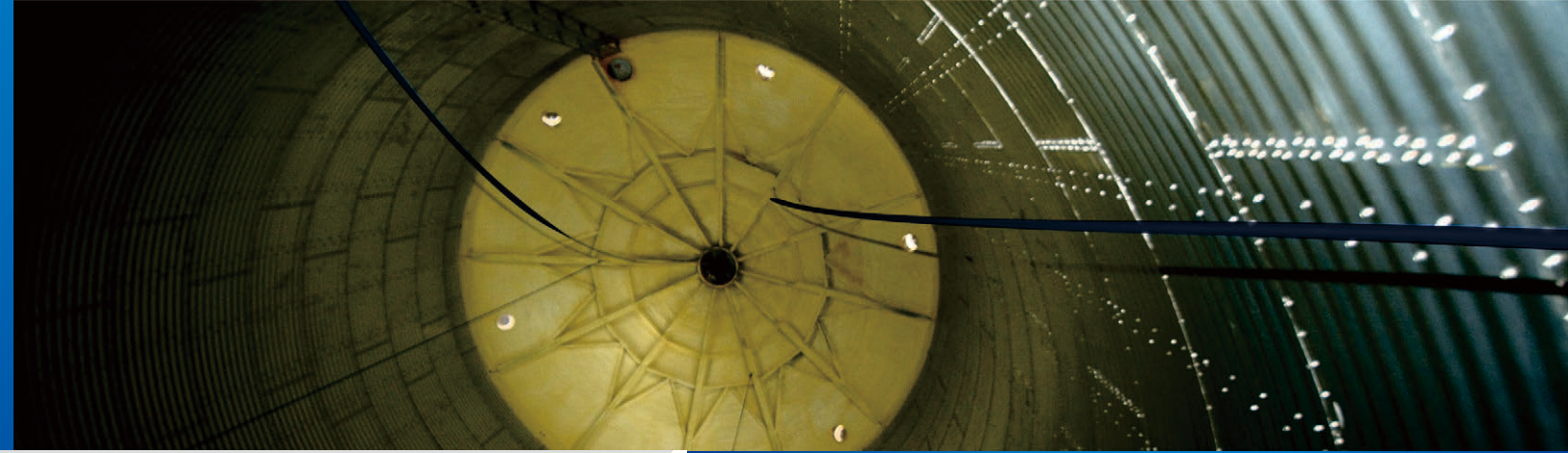

If the silo is bigger than 8 meters in diameter, we suggest the customer follows our guide of sensor number and sensor installation position to guarantee system can totally monitor temperature change of material inside the silo.

Silo diameter	EST sensor number	Silo center	First cycle			Second cycle			Third cycle		
			Radius (m)	Quantity	Interval angle	Radius (m)	Quantity	Interval angle	Radius (m)	Quantity	Interval angle
4	1	1									
6	1	1									
8	3	0	2.3	3	120						
10	3	0	2.5	3	120						
12	4	1	3.3	3	120						
14	6	1	4.7	5	72						
16	7	1	5.6	6	60						
18	8	1	6	7	51						
20	11	0	2.5	3	120	7.5	8	45			
22	12	0	2.8	3	120	8.2	9	40			
24	13	0	3	3	120	9	10	36			
26	17	1	5.3	6	60	10.6	10	36			
28	19	1	6.6	6	60	10.6	12	30			
30	22	0	2.6	3	120	7.5	7	51	12.8	12	30
36	29	0	2.5	3	120	8.5	10	36	14.5	16	22.5
40	34	1	5.6	5	72	11.3	10	36	17	18	20



# RCU2 Remote Control Unit



## Introduction

Remote Control Unit 2 (RCU2) is the solution for small and medium system with total sensor less than 8. RCU2 can be located on the wall at desired installation location, provide the display screen with touch user interface. The control unit is intuitive and convenient with the easy-to-use touch screen. RCU2 read data from sensor via RS485 interface, display on the screen, and can transmit to PC also.

## Features

- Easy-to-use touch screen, simple operation
- Using Microcomputer control, the operation time is more accurate
- Remote monitoring and control with long distance
- Anti-electric shock designed box, protect components inside
- RS485 communication interface (Modbus protocol)
- Integrated memory storage, can record data up to 90 days
- User Setting is available

## Specification

Power supply	100~220Vac,50/60Hz
Display	7 inches (800*480) TFT LCD
Touch panel	Resistive Touch
Voltage output	24Vdc (Maximum of 1A current output)
RAM	128 MB memory storage, 64MB RAM (record data up to 90 days)
Junction box dimensions	296*281*158 mm
Operating temp.	0°C to 50°C(20°C to 50°C Optional)
Storage temp.	-20~60°C
IP rate	IP 65
Maximum input sensors	8 sensors
Input/Output interface	Comport*2 (COM1 : RS232 、COM2 : RS485 2W/4W)



# Order Information



## EST110 multi-point temperature sensor

EST110-0030-10-30

Connection

	Size		Specification
Flange	E: 1-1/2"	I: 4"	M: 5kg/cm <sup>2</sup>
	F: 2"	J: 5"	N: 10kg/cm <sup>2</sup>
	G: 2-1/2"	K: 6"	O: 150Lbs
	H: 3"		P: 300Lbs

SS: Special connection  
 00: No flange  
 88: Hanging hook (ETB-0030)  
 99: Adjustable rotation angle mechanism (ETB-0040)

Length (Unit:m)

- 01: 1m(min.)
- 02: 2m
- ⋮
- 30: 30m(max.)

Sensor interval

- 05: One sensor every 0.5m
- 10: One sensor every 1m (std.)
- 15: One sensor every 1.5m
- 20: One sensor every 2.0m
- ⋮
- 95: One sensor every 9.5m (max.)

Sensor amount

- 01: 1PCS
- 02: 2PCS
- ⋮
- 30: 30PCS(max.)

## EST120 2 in 1 grain temperature & level monitoring transmitter

EST120-FM30-10-30

Connection

	Size		Specification
Flange	E: 1-1/2"	I: 4"	M: 5kg/cm <sup>2</sup>
	F: 2"	J: 5"	N: 10kg/cm <sup>2</sup>
	G: 2-1/2"	K: 6"	O: 150Lbs
	H: 3"		P: 300Lbs
Screw	3: 1-1/4"		R: PF(G) U: NPT

SS: Special connection  
 88: Hanging hook (ETB-0031)  
 99: Adjustable rotation angle mechanism (ETB-0041)

Length (Unit:m)

- 01: 1m(min.)
- 02: 2m
- ⋮
- 30: 30m(max.)

Sensor interval

- 05: One sensor every 0.5m
- 10: One sensor every 1m (std.)
- 15: One sensor every 1.5m
- 20: One sensor every 2.0m
- ⋮
- 95: One sensor every 9.5m (max.)

Sensor amount

- 01: 1PCS
- 02: 2PCS
- ⋮
- 30: 30PCS(max.)



# Order Information

## IPC contains MMS-TLA

- ETB-0001** IPC (traditional Chinese WIN7)  
+ MMS-TL  
+ RS485-USB converter (YTXPUSB485-T)
- ETB-0003** IPC(English WIN7)  
+ MMS-TL  
+ RS485-USB converter (YTXPUSB485-T)
- ETB-0005** IPC(simplified Chinese WIN7)  
+ MMS-TL  
+ RS485-USB converter (YTXPUSB485-T)

## HubLink

- JMH104-M** HubLink 1-wire
- JMW104-M** HubLink 1-wire wireless
- JMH101-M** HubLink RS485
- JMW101-M** HubLink RS485 wireless
- JMW10-CX** Coordinator
- JMW10-RX** Router

## RCU2 Remote Control Unit

RCU-2  0-

- Sensor type
  - 0: EST110 multi-point temperature sensor
  - 1: EST120 2 in 1 grain temperature & level monitoring transmitter
- Communication
  - 1: RS485
  - 2: Wireless
- Operating temperature
  - 0: Standard Type (0~50°C / 32~122°F)
  - 1: Lower Temperature Type (-20~50°C / -40~122°F)

## Accessories

