**User's
Manual**

**YFGW610
Field Wireless Media Converter**

IM 01W02D02-01EN

YFGW610 Field Wireless Media Converter

IM 01W02D02-01EN

This document contains important information for using YFGW610 Field Wireless Media Converter properly and safely. Please read this document thoroughly before using this product.

The configuration of the field wireless system is described in the User's Manual of YFGW410 Field Wireless Management Station (IM 01W02D01-01EN); read that document first.

CONTENTS

Introduction	i
Safety Precautions	ii
Copyright and Trademark Notices	vi
Information of User's Manual Revision	vii

Part-A. FUNCTIONS OF YFGW610

A1. Introduction.....	A1-1
A2. System Configuration.....	A2-1
A3. Function Configuration	A3-1
A4. Names of Parts	A4-1
A4.1 Front view	A4-1
A4.2 Side view	A4-1
A4.3 Rear view.....	A4-2
A4.4 Top view	A4-3
A5. LED Indications	A5-1
A6. Operational Element	A6-1
A7. Checking the Product	A7-1

Part-B. Installation

B1.	System Installation Specifications.....	B1-1
B2.	Power Supply and Grounding	B2-1
B2.1	Power Supply	B2-1
B2.2	Grounding.....	B2-2
B3.	Mounting	B3-1
B3.1	Mounting Direction	B3-1
B3.2	Mounting of DIN Rails.....	B3-2
B3.3	Installation of YFGW610.....	B3-3
B4.	Power, ground, and network cable connection	B4-1
B4.1	Connection Terminals and Communication Interface.....	B4-1
B4.2	Power Supply Cable Connection	B4-2
B4.3	Grounding.....	B4-6
B4.4	Network Cable Connection.....	B4-9
B5.	Explosion Protected Wiring	B5-1
B6.	Settings.....	B6-1

Part-C. Maintenance

C1.	Routine Maintenance	C1-1
C2.	Adding and replacing devices	C2-1
C3.	Maintenance in Hazardous Area.....	C3-1
C4.	Parts with Defined Life Spans.....	C4-1

Part-D. Troubleshooting

Part-E. Specifications

E1.	Standard Specification	E1-1
E2.	Model and Suffix Codes.....	E2-1
E3.	External Dimensions.....	E3-1

Introduction

■ Regarding This User's Manual

- **This manual should be provided to the end user. Please recommend end users to keep this manual at hand and refer to it as needed.**
- **Before use, read this manual thoroughly to comprehend its contents.**
- **The purpose of the User's Manual is to describe details of functions provided in this product, not to warrant the product's suitability to the specific purposes of customers.**
- **No part of this manual may be reproduced in any form without Yokogawa's written permission.**
- **The contents of this manual may be changed without prior notice.**
- **All reasonable effort has been made to ensure the accuracy of the contents of this manual. However, if any errors or omissions are found, please inform any of sales offices listed on the back cover or your local distributor.**
- **Special specifications are not described.**
- **Please note that this User's Manual may not be revised for any specification changes, construction changes or operating part changes that are not considered to affect function or performance.**

Safety Precautions



NOTE

Be sure to read the safety precautions for this product described in “YFGW610 Field Wireless Media Converter Read Me First (IM 01W02D02-11EN)”.
This instrument has been tested and certified as being explosion protected type. Be sure to read safety precautions and explosion protected type specifications described in “YFGW610 Field Wireless Media Converter Read Me First (IM 01W02D02-11EN)” before the installation and operation of this instrument.

■ Safety, Protection, and Modification of the Product

- The following symbols are used in the product and User’s Manual to indicate that there are precautions for safety:



WARNING

Indicates a potentially hazardous situation which, if not avoided, could result in death or serious injury.



CAUTION

Indicates a potentially hazardous situation which, if not avoided, may result in minor or moderate injury or physical damage. It may also be used to alert against unsafe practices.



IMPORTANT

Indicates that operating the hardware or software in this manner may damage it or lead to system failure.



NOTE

Draws attention to information essential for understanding the operation and features.

TIP Indicates additional information. Indicates additional information.

SEE ALSO Indicates a reference source.

- ⊕ Indicates a protective grounding terminal. Before using the product, ground the terminal.
- ⊥ Indicates a functional grounding terminal. Before using the product, ground the terminal.
- == Indicates a DC supply

■ Warranty

- **The warranty terms of this instrument are described in the quotation. We will make any repairs that may become necessary during the guarantee period free of charge.**
- **Please contact our sales office or your local distributor if this instrument requires repair.**
- **If the instrument is faulty, contact us with complete details about the problem and the length of time it has been faulty, and state the model and serial number. We would appreciate the inclusion of drawings or additional information.**
- **The results of our examination will determine whether the product will be repaired free of charge or on an at-cost basis.**

■ The guarantee will not apply in the following cases:

- **Damage due to negligence or insufficient maintenance on the part of the customer.**
- **Problems or damage resulting from handling, operation or storage that violates the intended use and specifications.**
- **Problems resulting from using or performing maintenance on the instrument in a location that does not comply with the installation location specified by Yokogawa.**
- **Problems or damage resulting from repairs or modifications not performed by Yokogawa or someone authorized by Yokogawa.**
- **Problems or damage resulting from inappropriate installation after delivery.**
- **Problems or damage resulting from disasters such as fires, earthquakes, storms, floods, or lightning strikes and external causes.**

■ Warranty and Disclaimer

- Yokogawa assumes no responsibilities for this product except as stated in the warranty.
- Yokogawa shall have neither liability nor responsibility to any person or entity with respect to any direct or indirect loss or damage arising from using the product or any defect of the product that Yokogawa can not predict in advance.

■ Notes on Hardware

● Appearance and Accessories

Check the following when you receive the product:

- Appearance
- Standard accessories

Contact our sales representative or your local distributor if the product's coating has come off or any accessories are missing.

● Model and Suffix Codes

The name plate on the product states the model and suffix codes. Compare them with those in the general specification to make sure the product is the correct one. If you have any questions, contact our sales office or your local distributor.

■ Cautions for Safely Using the Device

● EMC Conformity Standards

EN 61326-1 Class A, Table 2, EN 61000-6-2, EN 55011 Class A, Group 1

* This instrument is a Class A product, and is designed for use in industrial environments. Please use this instrument in industrial environments only.

■ About Laser

YFGW610-C is compliant with IEC 825-1 Class 1 and CDRH 21-CFR 1040 Class 1 eye safety requirements.



CAUTION

- To avoid eye injury although, please do not see a light source.
-

Copyright and Trademark Notices

■ All Rights Reserved

The copyrights of the media and this manual are reserved.

No part of this manual may be transferred, sold, distributed (including delivery via a commercial PC network or the like), or registered or recorded on video tape or other media.

■ Trademark Acknowledgments

- Ethernet is a registered trademark of XEROX Corporation.
- All other company and product names mentioned in this User's Manual are trademarks or registered trademarks of their respective companies.
- We do not use TM and ® to indicate trademarks or registered trademarks in this User's Manual.

Information of User's Manual Revision

Material Name : YFGW610 Field Wireless Media Converter

Material Number : IM 01W02D02-01EN

Edition	Date	Page	Revised Item
1st Edition	September 2012		New Issue
2nd Edition	March 2016	Introduction ii A7-1 B4-6 B5-1, C3-1, E1-1 E2-1	Revise description about safety precautions Add IM 01W02D02-11EN(Read Me First) Add description about the tightening torque of the frame ground M4 screw. Revise description about explosion protected type product and CE Conformity.
3rd Edition	March 2018	Introduction v B1-1 Part E all	Add "About Laser" Add "Safety Conformity Standards" Update Specifications Modify alert symbol mark and signal word

Part-A. FUNCTIONS OF YFGW610

A1. Introduction

Read the User's Manual (IM 01W02D01-01EN) of YFGW410 Field Wireless Management Station (hereafter simply referred to as YFGW410) before this manual.

YFGW610 Field Wireless Media Converter (hereafter simply referred to as YFGW610) converts the signals between 100BASE-TX (metal network cable) and 100BASE-FX (optical network cable) and is used when the wiring between the Field Wireless Management Station and the Field Wireless Access Point is placed outdoors or covers a long distance.

YFGW610, installed near of YFGW410, converts the optical network connection of YFGW510/YFGW520 Field Wireless Access Point (hereafter simply referred to as YFGW510/YFGW520) to the metal network connection.

For detail of YFGW510 specifications, refer to GS 01W02E01-01EN. For detail of YFGW520 specifications, refer to GS 01W02E02-01EN.

A2. System Configuration

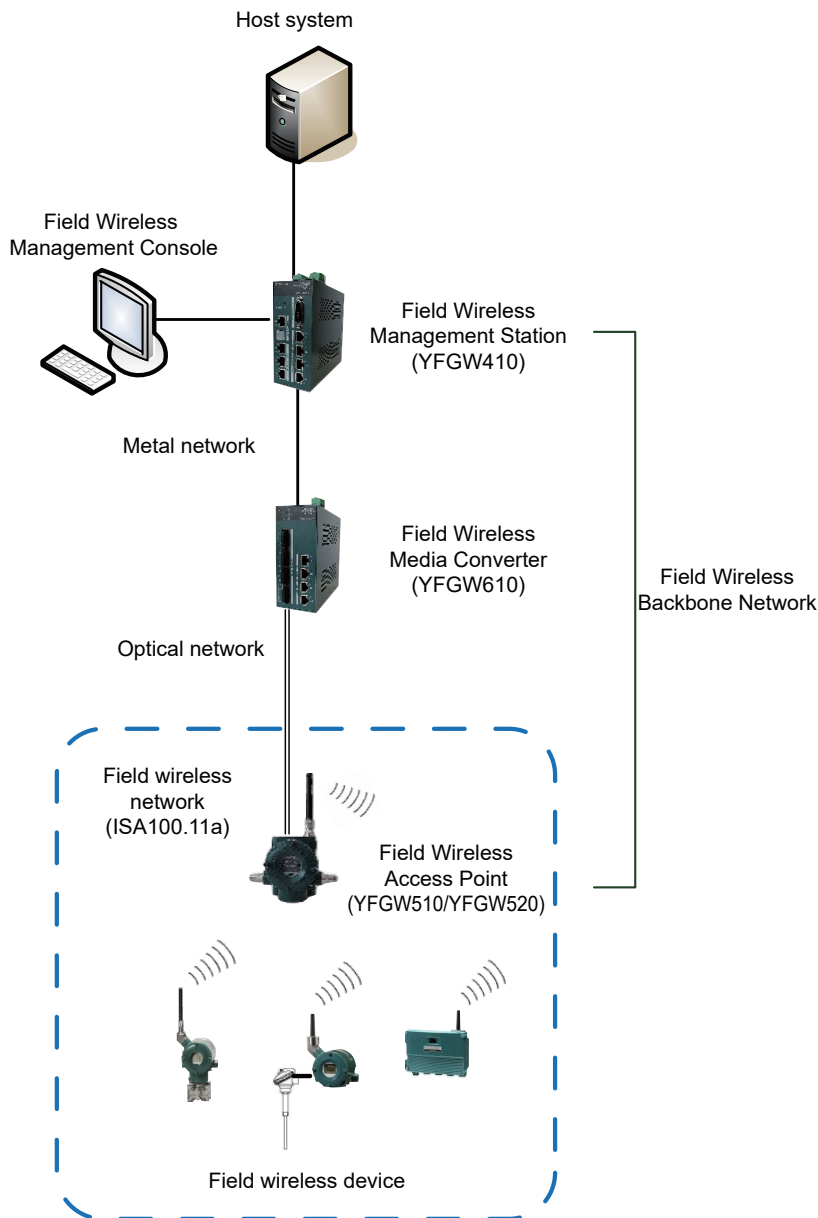

FA0201

Figure A2-1 Example of system configuration

YFGW610 is installed near YFGW410 in the field wireless backbone, and converts the optical network connection of YFGW510/YFGW520 to the metal network connection for YFGW410.

A3. Function Configuration

The block diagram below describes the communication interface functions of YFGW610.

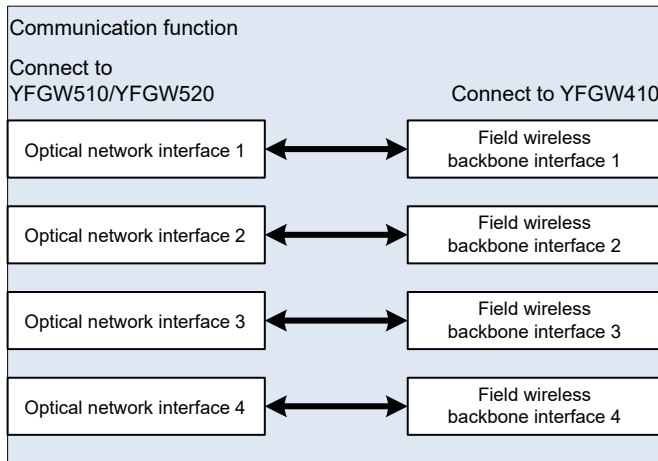

FA0301

Figure A3-1 YFGW610 communication interface functions

Conversion is carried out between interfaces with the same number.
When install or replace, YFGW610 is unnecessary to configure itself.

A4. Names of Parts

A4.1 Front view

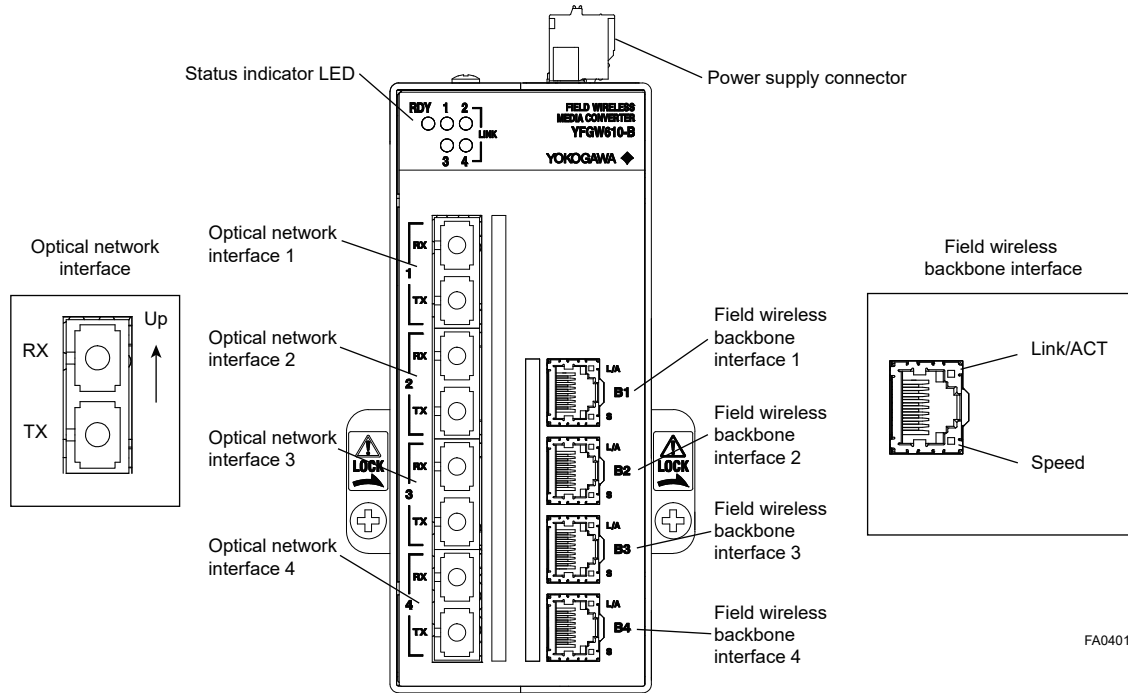

FA0401

Figure A4-1 Front view

There are 13 LEDs on the front face: one status indicator LED and four status indicator LEDs for the optical network interface are on the top, and four pairs of status indicator LEDs (for Link/ACT and Speed status) are incorporated in the field wireless backbone interface.

A4.2 Side view

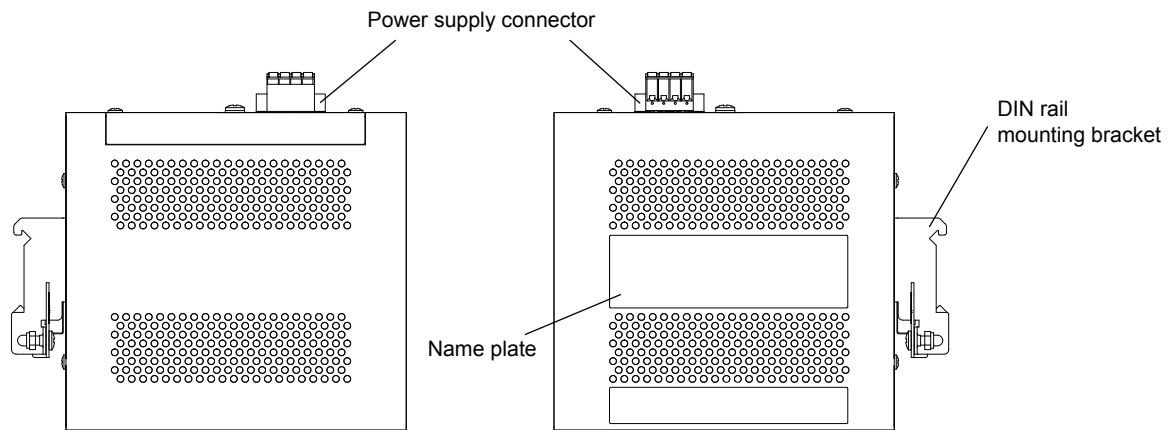

FA0402

Figure A4-2 Side view

There are no terminals or parts to operate on either side except for the air inlets for cooling. Place the product at a sufficient distance from other devices so that these inlets are not blocked. For details, see B3 Installation.

A4.3 Rear view

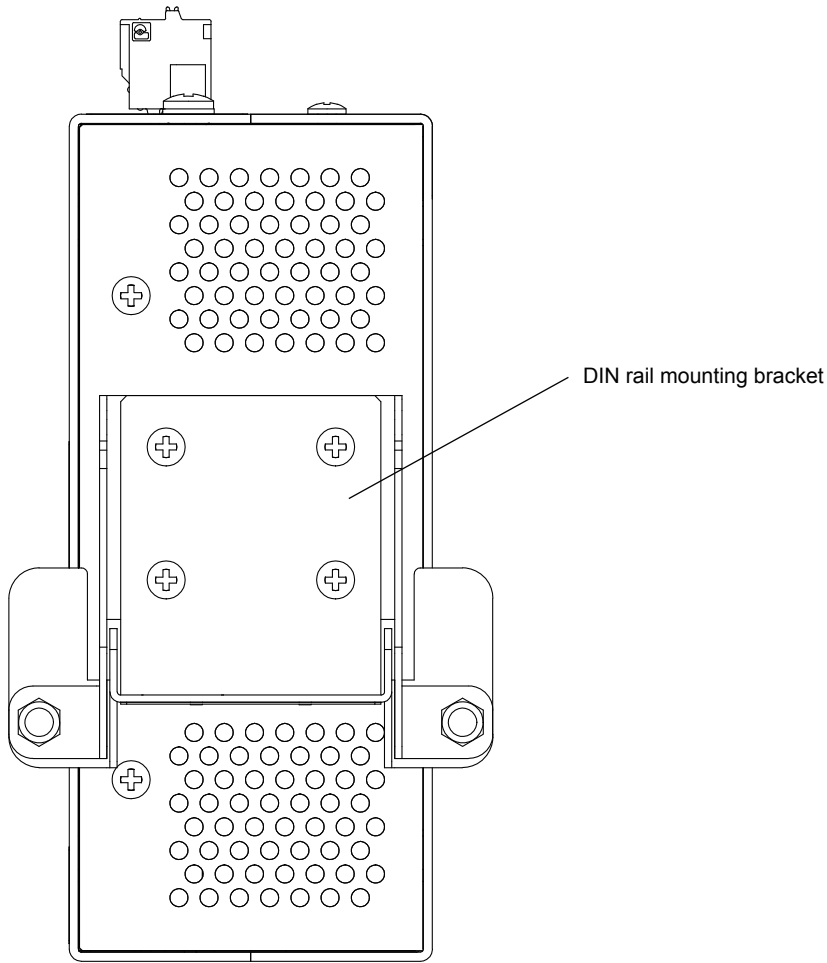

FA0403

Figure A4-3 Rear view

On the back of YFGW610, there is a mounting bracket to mount to a DIN rail. YFGW610 supports DIN rail mounting alone.

A4.4 Top view

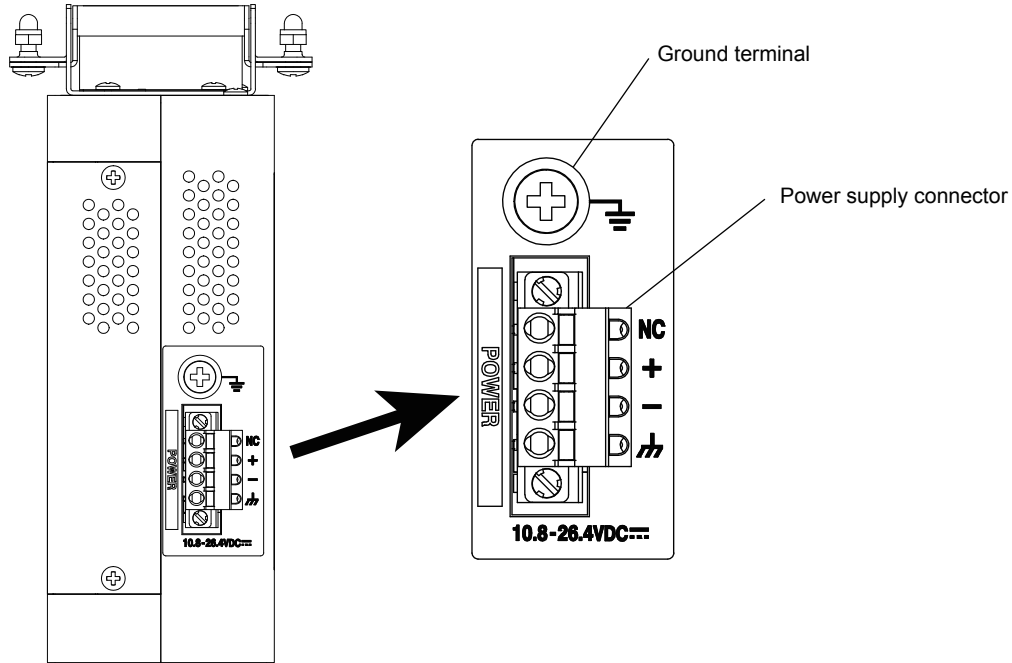

FA0404

Figure A4-4 Top view

There are power supply connectors and a ground terminal on the top of YFGW610.

The spring terminals, which are the main components of the power supply connector to connect external wiring, are fixed by fastening the two screws of the terminals in the sockets of the housing.

A5. LED Indications

The LED indications are as follows.

Table A5-1 LED indications

LED		Function
RDY		Indicates the status of YFGW610
LINK	1	Indicates the status of optical network interface 1
	2	Indicates the status of optical network interface 2
	3	Indicates the status of optical network interface 3
	4	Indicates the status of optical network interface 4
Link/ACT Speed (RJ-45 connector)	1	Indicates the status of field wireless backbone interface 1
	2	Indicates the status of field wireless backbone interface 2
	3	Indicates the status of field wireless backbone interface 3
	4	Indicates the status of field wireless backbone interface 4

The meanings of respective indications of the status indicator LED are as follows.

Table A5-2 Status indicator LED

Indication	Status	Description
Orange	Booting	
Green	Normal operation	
Red	Abnormal operation	Abnormal hardware operation

The meanings of respective indications of the status indicator LED for the optical network interface are as follows.

Table A5-3 Status indicator LED for optical network interface

Indication	Status
Green	Enable optical communication
OFF	No signals detected

The meanings of respective indications of the status indicator LED for the field wireless backbone interface are as follows.

Table A5-4 Status indicator LED for field wireless backbone network interface

Indication		Status
Link/ACT	Green	Link up
	Green blink	Communicating
	OFF	Link down
Speed	Green	100BASE-TX communicating
	OFF	10BASE-T communicating

A6. Operational Element

YFGW610 does not have any switches or buttons that can be mechanically operated from the outside of the housing.

A7. Checking the Product

When you receive YFGW610, please check that the product specifications match your order, all items are included, and there is no damage, stains, or other problems.

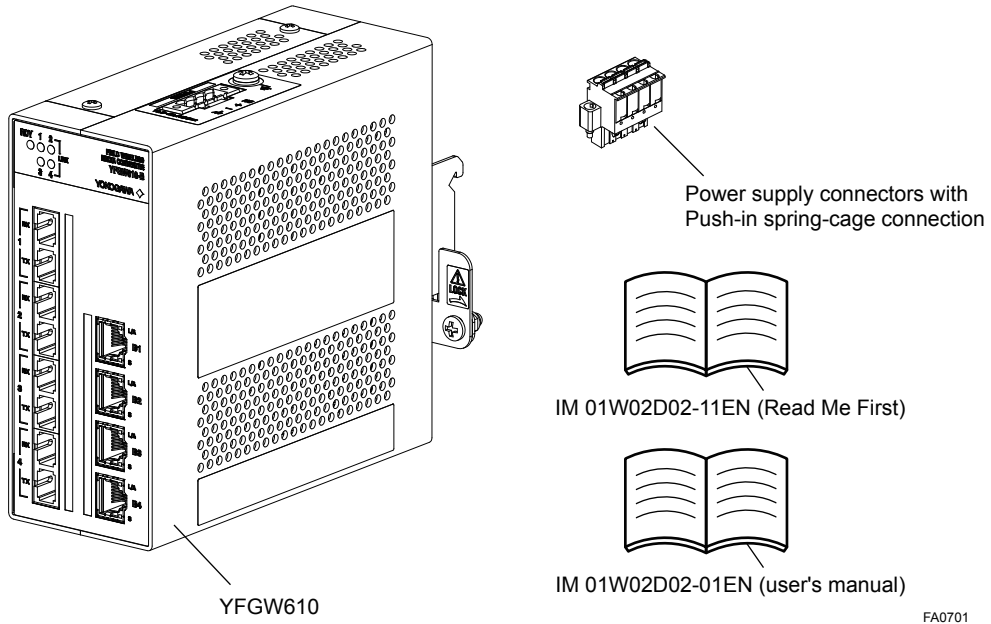

Figure A7-1 Checking the product

FA0701

Part-B. Installation

This section describes the installation of YFGW610.

Use YFGW610 in the following procedure.

1. Installation of YFGW610
2. Wiring of the power supply, ground and network cable

B1. System Installation Specifications

The system must be installed in an appropriate environment to ensure stable system operation.

The following defines the detailed specifications of YFGW610 installation environment.

Table B1-1 System installation specifications

Item		Specifications	Applicable standards
Ambient temperature	Operating	-40 to 65°C	
	Transport /storage	-40 to 85°C	
Ambient humidity	Operating	5 to 95% relative (without condensing)	
	Transport /storage	5 to 95% relative (without condensing)	
Temperature gradient	Operating	Within +/-10°C per hour	JEIDA 29 Class B
	Transport /storage	Within +/-20°C per hour	
Protection class		IP20	IEC529
Vibration resistance		0.15 mm P-P (5 to 58 Hz)	IEC68-2-6
		1 G (58 to 150 Hz)	
Impact resistance		15 G 11 ms (de-energized, with half-sine wave pulse in three directions)	IEC68-2-27
Altitude		Up to 3000 meters	
Noise level	Electric field	3 V/m or less (80 MHz to 1 GHz)	
	Electrostatic discharge	4 kV or less (contact discharge), 8 kV or less (aerial discharge)	
Grounding		Class D grounding (100 ohms or less)	
Cooling		Natural cooling	
Mounting		Mounted on DIN rails	
Power supply	Voltage range	10.8 to 26.4 V DC	The equipment shall not be operated outside the range.
	Rated voltage	24 V DC	
	Allowable ripple	Less than 1% p-p	
Power consumption		10 W	



IMPORTANT

- The temperature specification during operation indicates the criterion of the temperature at the air intake of the bottom portion of modules. Do not block ventilation holes, as it may hinder the air-cooling capabilities of the unit. When installing YFGW610 in a cabinet, note that the temperature specification is not in respect to the ambient temperature of the cabinet. Provide cooling fans in the cabinet if needed.
- Avoid exposing YFGW610 to direct sunlight.
- Prevent condensation under any circumstance.
- The dust level of the room should not exceed 0.3 mg/m³. Under any circumstance, avoid iron flakes, carbon particles, or any other type of dust that are conductive.
- Avoid existence of corrosive gases such as hydrogen sulfide, sulfurous acid gas, chlorine, and ammonia.

■ YFGW610 Vibration Criteria

Ensure that if the frequency of vibration at the installation location is 58 Hz or less, the total amplitude is maintained less than 0.15 mm. If the vibration frequency is greater than 58 Hz, find allocation that will meet the following condition:

$$\text{Acceleration (m/s}^2\text{)} = 2\pi^2 \times A \times F^2 \times 10^{-3} < 9.8 (=1 \text{ G})$$

where

A : Total amplitude (mm)

F : Frequency (Hz)

The range of allowable total amplitudes is shown below.

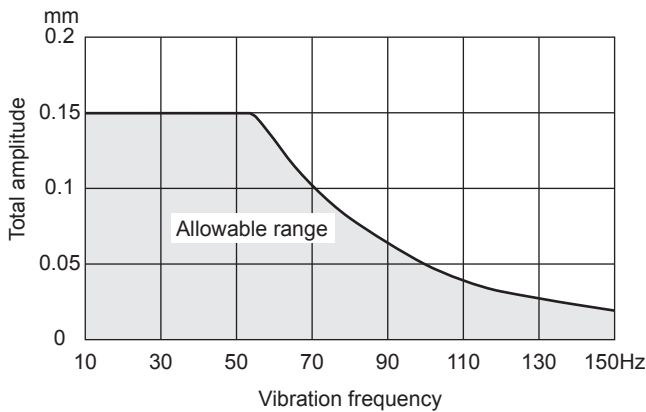

■ Radio Device Noise to YFGW610

The following shows general requirements when using a radio device such as transceivers; however, as a general rule, close the cabinet door when using a radio device:

- Transceivers that have 3 W of output power or less should be at least 1 m away. Transceivers that have 10 W of output power or less should be at least 2 m away.
- Radio devices that have 1 W of output power or less including cellular phones and cordless phones should be at least 1 m away.
- The field wireless device radio output is about 10 mW. There is no impact for YFGW610, but keep to 1 m than the same way as the 1 W output radio device.

B2. Power Supply and Grounding

A reliable power supply is required to ensure stable YFGW610 operations.

B2.1 Power Supply

Connect the power source to the power supply connector on the top of YFGW610.

SEE ALSO

For power supply and current consumption of YFGW610, also see "GS 01W02D02-01EN".

Inrush current

When the power is turned on, inrush current may run into the device. As shown in the table below, this current is, even though short-lived, significantly larger (10 times or more) than the steady state current. Make sure that the power supply and protector can endure the inrush current.

Item	Specifications	Remarks
Inrush current	30 A, 2 msec or less	At 26.4 V DC

SEE ALSO

For wiring of the power supply, see "B4.2 Power Supply Cable Connection."



IMPORTANT

- If the power fails when downloading the system configuration data from YFGW410 or YFGW510/YFGW520 to field wireless devices by using the Field Wireless Management Console, the configuration data may be destroyed. (However, the system configuration data will not be destroyed even if the power fails during normal system operation.)
- To avoid such a problem, supply the power source from the permanent power supply unit.



NOTE

- YFGW610 does not have a power switch. Provide a breaker or switch for the external power line to turn on/off the device.
- The overcurrent protection circuit of the power supply, it is recommended to use the automatic-recover type with the reverse L-shaped.

B2.2 Grounding

Appropriate grounding is necessary for the stable operation of YFGW610. Class D grounding (the third class grounding) with the ground resistance of 100 ohms or less is necessary. To connect the ground cable to YFGW610 directly, use the frame ground (FG) terminal on the top side of the housing.

SEE
ALSO For grounding of YFGW610, see "B4.3 Grounding."

B3. Mounting

Mount YFGW610 on the DIN rails being secured to the general-purpose instrumentation board or others. No other type of mounting is allowed.

B3.1 Mounting Direction

YFGW610 is cooled down by natural air flow. Install it correctly.

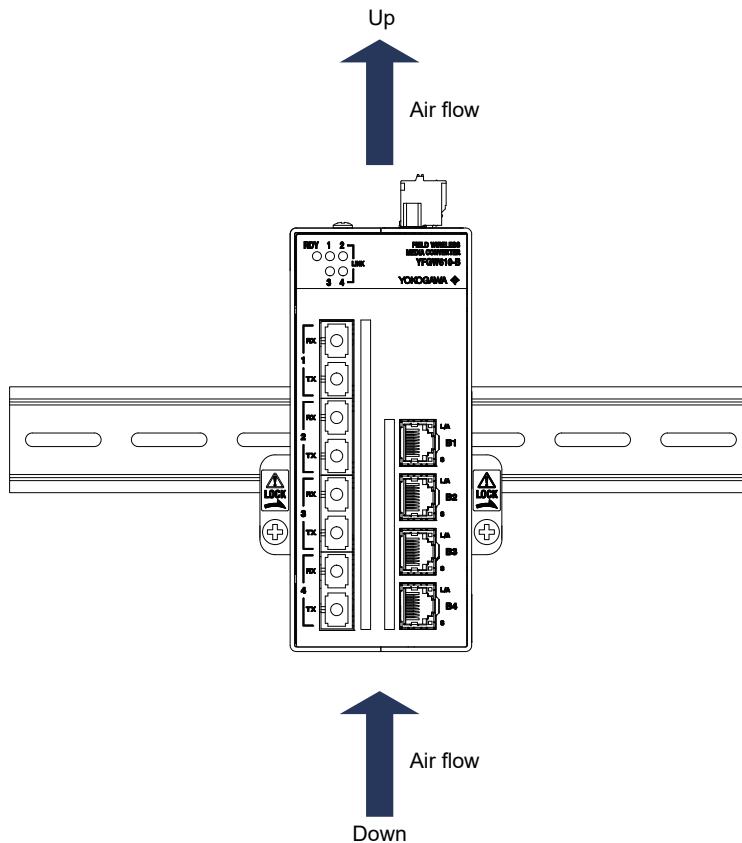

FB0301

Figure B3-1 Mounting direction



IMPORTANT

- Before installing or removing YFGW610, be sure to turn its power supply off.
- Install the device to allow smooth air flow through the ventilation holes.
- To allow smooth air flow for natural cooling, secure at least 150 mm between the device's top panel and other devices. Be also sure to leave at least 100 mm between the device's bottom and other devices.
- To allow smooth routing of power supply and network cables and to avoid heat from adjacent devices, leave at least 50 mm between the device's each side and other devices.
- Keep YFGW610 away from direct sunlight.

B3.2 Mounting of DIN Rails

First, install the DIN rails on the general-purpose instrumentation board or the cabinet wall. Secure the DIN rails by tightening the appropriate number of screws. Be careful that the rails do not get bent or deformed due to the weight of YFGW610 or cable tension.

To securely ground YFGW610, insert an insulation bushing between the DIN rails and mounting panel and tighten the screws. Insulate the DIN rails from the metal surface of the mounting panel.

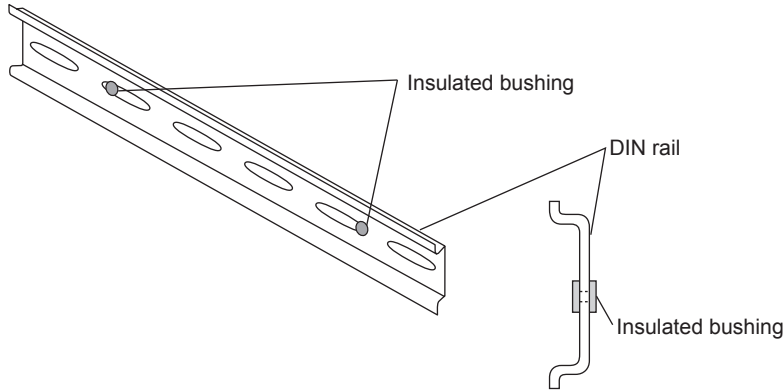

B3.3 Installation of YFGW610

1. Loosen the screws at both sides of the DIN rail mounting bracket (located on the rear panel), by rotating these screws in the reverse direction from the “Lock” position. The screws do not drop even when fully loosened.
2. As shown in Figure B3-2, hook the top edge of the DIN rail mounting bracket onto the top of the DIN rail, and return YFGW610 back to the horizontal position. Then, hook the bottom edge of the mounting bracket onto the bottom of the DIN rail.
3. Tighten the screws at both ends of the DIN rail mounting bracket, by rotating them toward the “Lock” position. Tighten screws securely to ensure there is no clearance between YFGW610 and the DIN rails.
4. To remove YFGW610, follow the procedure described above in reverse. Loosen the screws by three turns.

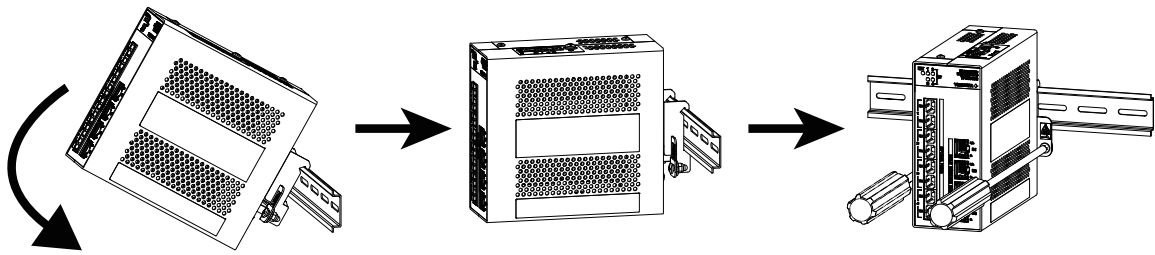

FB0302

Figure B3-2 Mounting of YFGW610 on DIN rail

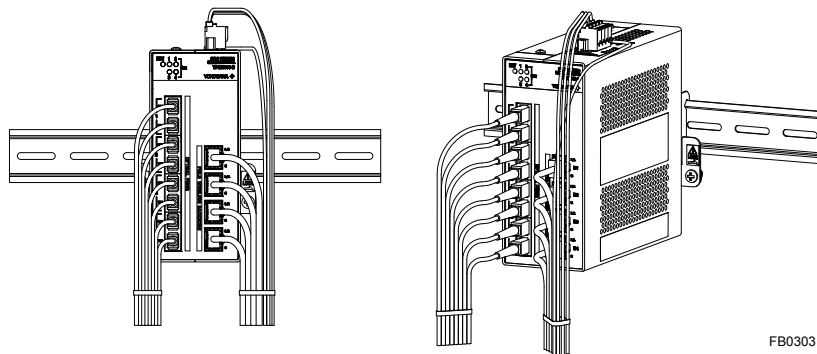

FB0303

Figure B3-3 Mounting example of YFGW610 on DIN rail

B4. Power, ground, and network cable connection

This section explains the power, ground, and network cable connection to YFGW610.

B4.1 Connection Terminals and Communication Interface

Connect cables as follows;

Power supply cable: to the spring terminals of YFGW610

Ground cable (with a ring-type crimp terminal): to the ground terminal by using the screw

Metal network cable conforming to the 100BASE-TX standard, terminated with an RJ-45 connector: to the field wireless backbone interface

Optical network cable conforming to the 100BASE-FX standard, terminated with an SC connector: to the optical network interface

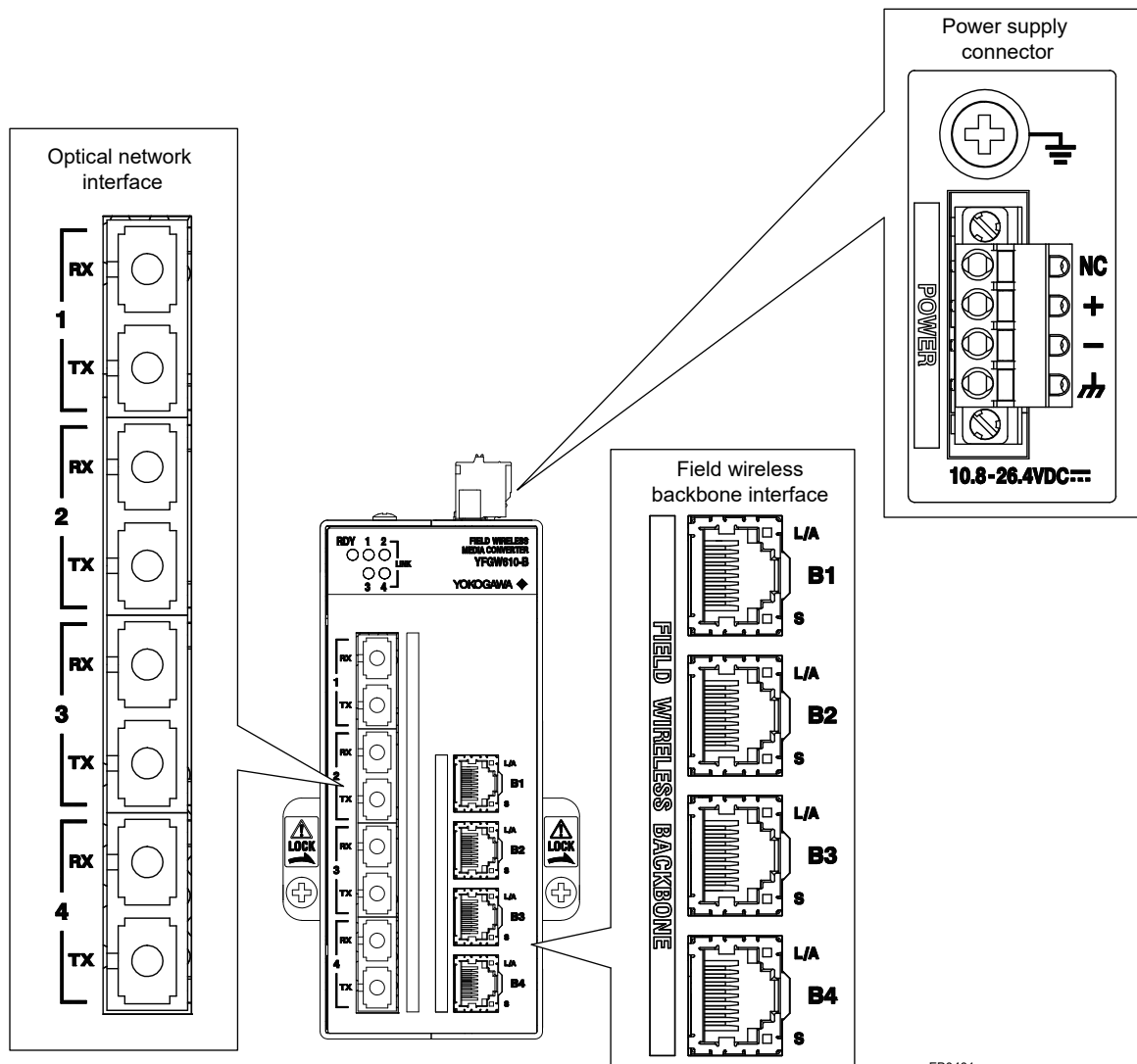

Figure B4-1 Connection terminals and communication interfaces

FB0401

B4.2 Power Supply Cable Connection

YFGW610 has a 4-pin power connector (with a spring terminal; Phoenix Contact's FKC 2.5/4-STF) and the socket on the device itself. The spring terminal is secured by two screws at both ends. You can separate the terminal from the socket by loosening these screws.

If you have enough space for cabling at the top and side panels of YFGW610, leave the spring terminals on YFGW610 (as shown in Figure B4-2) and connect the positive and negative power lines as indicated.

If there is insufficient space, separate the spring terminals from the socket, route the cables, and put it back to the housing.



NOTE

- Be careful to connect the power supply cable with correct polarity
- YFGW610 does not have a power switch. Provide a breaker or switch for the external power line to turn on/off the device.

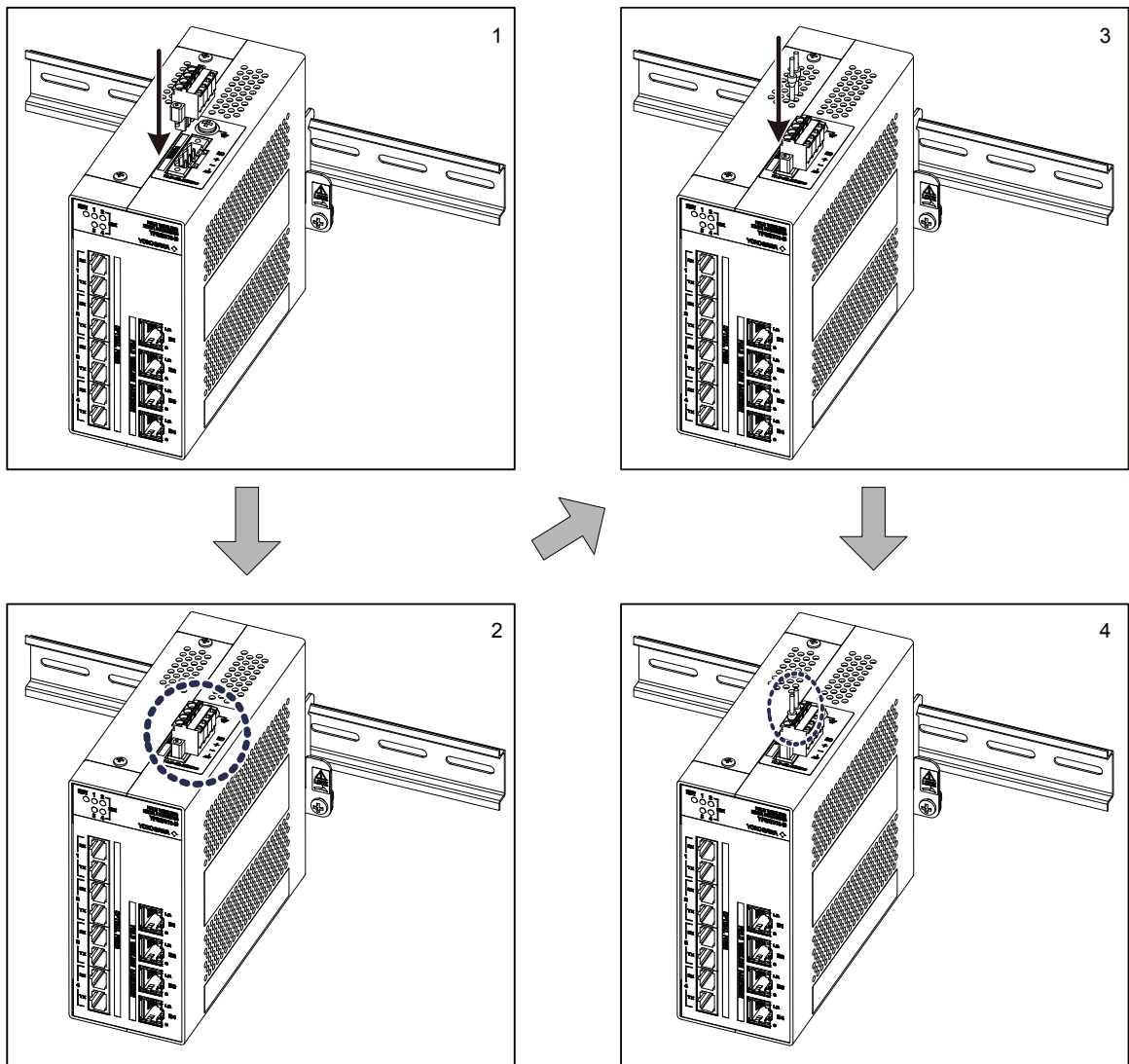

FB0402

Figure B4-2 Power supply cable connection procedure

To disconnect the power supply cable from the spring terminal, push down the orange areas around the cable inlet and pull out the power supply cable from the socket.

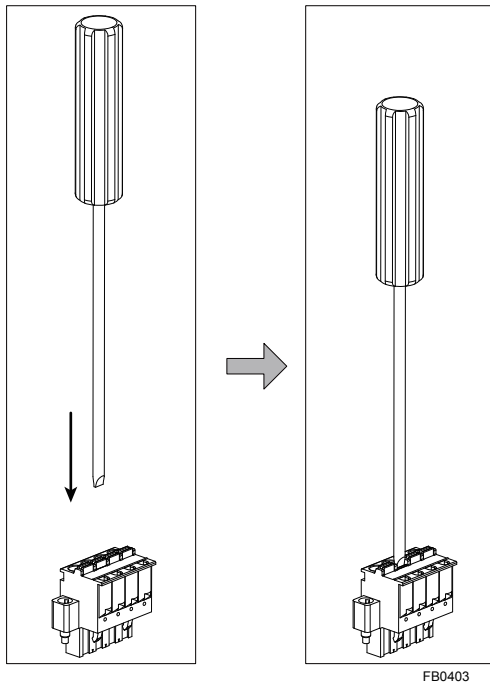

Figure B4-3 Disconnecting the power supply cable

● Applicable cables

Insulated cables for industrial equipment such as;

- 600 V polyvinyl chloride insulated wires (IV); JIS C3307
- Polyvinyl chloride insulated wires for electrical apparatus (KIV); JIS C3316
- 600 V grade heat-resistant polyvinyl chloride insulated wires (HIV); JIS C3317
- Heatproof vinyl insulated wires VW-1 (UL1015/UL1007)
- Control cables (vinyl insulated vinyl sheath cable) (CVV); JIS C3401

● Wire Size

- Without sleeve: 0.2 mm² to 3.3 mm² (AWG24 to 12)
- With sleeve: 0.2 mm² to 2.5 mm² (AWG24 to 14)

● **Wiring to spring terminals: 1 (without sleeve)**

- When using a solid conductor, strip the insulated cover and connect it.
Strip the solid conductor by 10 mm.
- When using a stranded conductor, strip the insulated cover and twist and connect it.
Strip the stranded conductor for 10 mm.

Never solder the stranded conductor when connecting cables.

Be careful not to cause the loosely stranded conductor to come in contact with adjacent terminals or others. Insert the cable leads into the terminal block securely.

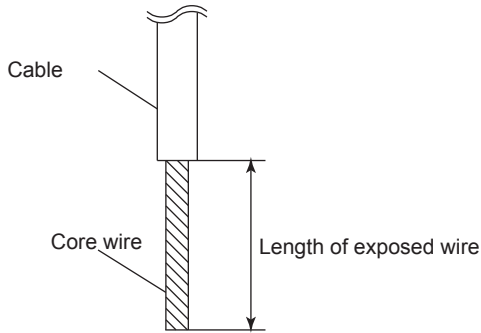

● **Wiring to spring terminals: 2 (with sleeve)**

The sleeve can prevent cable leads from untwist when you connect the cable. Select a sleeve to match the cable size. If the length of cable leads does not match the length of sleeve (l_2), strip the cable to the correct length. Strip the cable for a length so that the core wire slightly extends from the metal tube of the sleeve. If this causes the length of the metal tube of the sleeve to be slightly shorter than the stripping length, this is no problem.

The wiring cables and applicable sleeves are listed in the table below.

Use the same manufacturer for sleeves and tools.

Example of tool: Phoenix Contact's CRIMPFOX 6

For details on sleeves and crimp tools, contact to Phoenix Contact Inc.

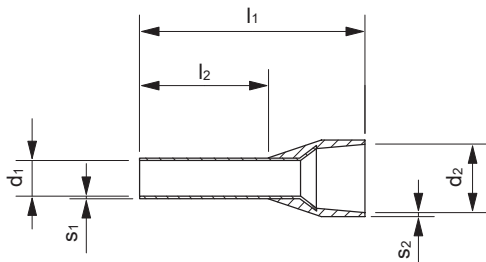

Table B4-1 List of power supply cables

Cable			Dimensions (mm)						Phoenix Contact's type
Section area (mm ²)	AWG	Strip length (mm)	l ₁	l ₂	d ₁	S ₁	d ₂	S ₂	
0.25	24	10	10.5	6.0	0.8	0.15	2.0	0.25	AI 0.25-6 BU
0.34	22	10	10.5	6.0	0.8	0.15	2.0	0.25	AI 0.34-6 TQ
		10	12.5	8.0	0.8	0.15	2.0	0.25	AI 0.34-8 TQ
0.5	20	10	12.0	6.0	1.1	0.15	2.5	0.25	AI 0.5-6 WH
		10	14.0	8.0	1.1	0.15	2.5	0.25	AI 0.5-8 WH
		10	16.0	10.0	1.1	0.15	2.5	0.25	AI 0.5-10 WH
0.75	18	10	12.0	6.0	1.3	0.15	2.8	0.25	AI 0.75-6 GY
		10	14.0	8.0	1.3	0.15	2.8	0.25	AI 0.75-8 GY
		10	16.0	10.0	1.3	0.15	2.8	0.25	AI 0.75-10 GY
1.0	18	10	12.0	6.0	1.5	0.15	3.0	0.3	AI 1-6 RD
		10	14.0	8.0	1.5	0.15	3.0	0.3	AI 1-8 RD
		10	16.0	10.0	1.5	0.15	3.0	0.3	AI 1-10 RD
1.5	16	10	12.0	6.0	1.8	0.15	3.4	0.3	AI 1.5-6 BK
		10	14.0	8.0	1.8	0.15	3.4	0.3	AI 1.5-8 BK
		10	18.0	10.0	1.8	0.15	3.4	0.3	AI 1.5-10 BK
2.5	14	10	14.0	8.0	2.3	0.15	4.2	0.3	AI 2.5-8 BU
		10	16.0	10.0	2.3	0.15	4.2	0.3	AI 2.5-10 BU

**NOTE**

- Use the same manufacturer for sleeves and tools.
- Use sleeve tools that match the wire thickness.
- Insert the wire to be connected completely into the pressure clamp terminal and attach it securely.
- Secure the cable to cable clamps, etc. so that the weight of the cable applied to the terminal is minimized.

B4.3 Grounding

Secure grounding is required to ensure stable YFGW610 operations. YFGW610 has two ground terminals: the frame ground (FG) terminal secured by the M4 screw at the side of the power connector, and the ground terminal at the power supply spring terminal.

Connect the ground leads from the frame ground (FG) terminal to the ground. Connect the cable shield or others to the power supply spring terminal. The internal wiring of YFGW610 housing is connected as shown in the following figure.

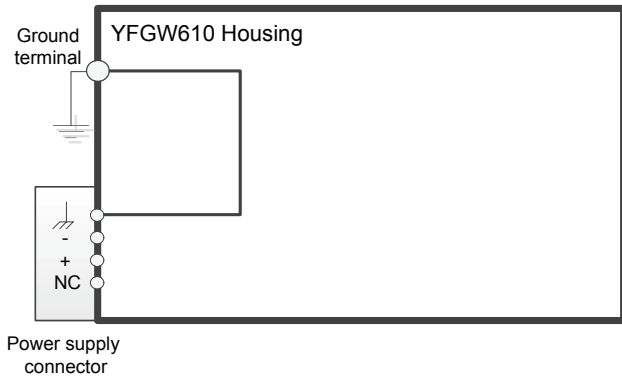

FB0404

Figure B4-4 Internal connection of the ground terminal

To ensure stable grounding, use the insulation bushings or others and functionally insulate the entire board or DIN rails with the device from the metal surface of external cabinet, rack and others. Then, connect the leads from YFGW610 to the ground. Directly connect the leads from the FG terminal screw to the Class D grounding with the 100 ohms or less grounding resistance. To connect the ground cable to YFGW610 directly, use the frame ground (FG) terminal (M4 screw) on the top side of the main body. Secure the M4 screws at a tightening torque of 1.2 to 1.5 Nm. Do not share the ground leads with other devices.

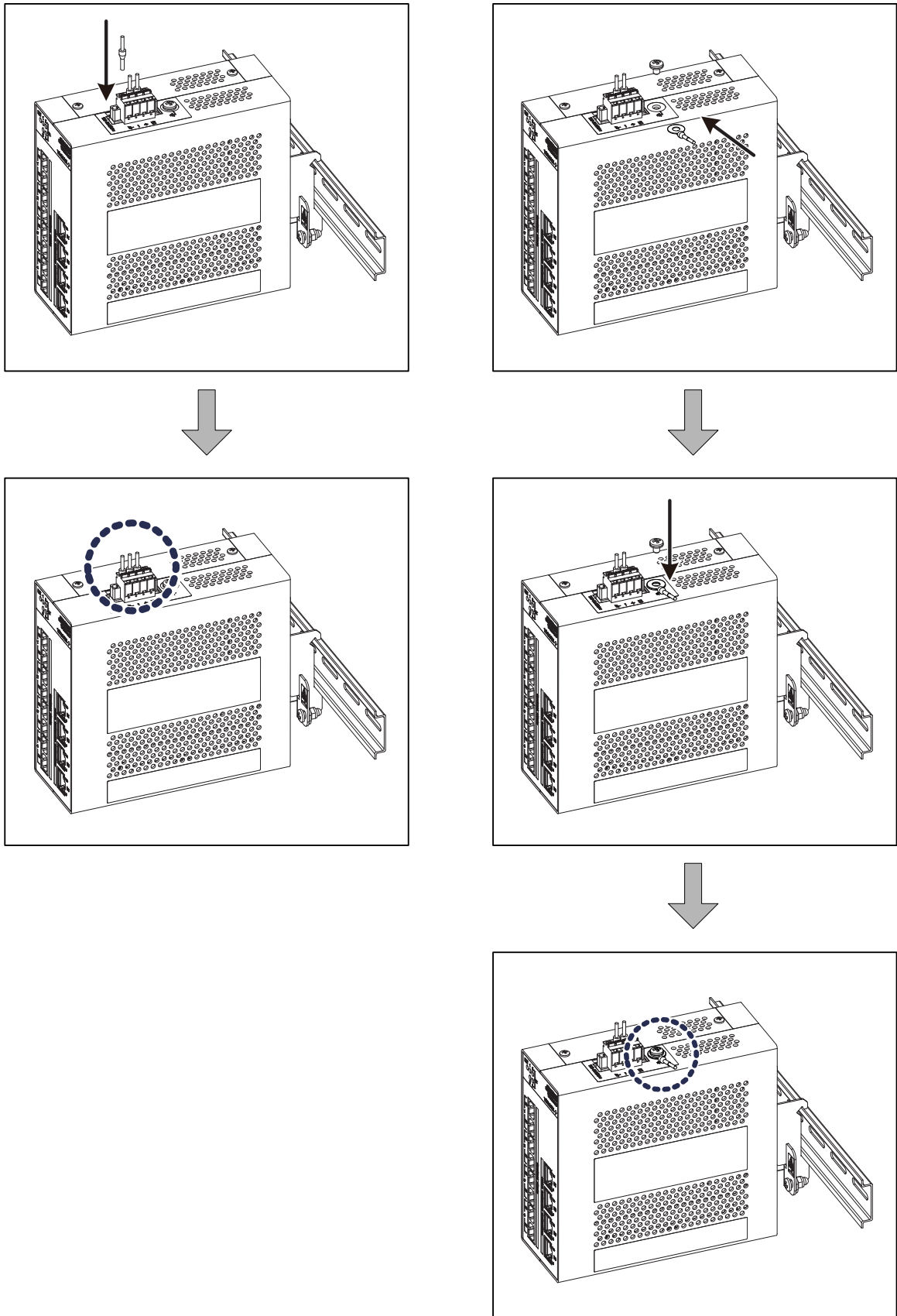

FB0405

Figure B4-5 Grounding terminal connection procedure

- **Applicable cables**

Insulated wires for industrial equipment

Examples:

- 600 V polyvinyl chloride insulated wires (IV): JIS C3307
- Polyvinyl chloride insulated wires for electrical apparatus (KIV): JIS C3316
- 600 V grade heat-resistant polyvinyl chloride insulated wires (HIV): JIS C3317
- Heatproof vinyl insulated wires VW-1 (UL1015/UL1007)

- **Wire Size**

Core: 2 mm² to 2.6 mm² (AWG14 to 13)

- **Termination**

Use a ring tongue terminal for M4 terminals: with an insulation sleeve

B4.4 Network Cable Connection

■ Field wireless backbone (YFGW410 side) wiring

Connect the 100BASE-TX conforming to metal network cable, terminated with an RJ-45 connector, to the field wireless backbone interface (YFGW410 side) on the right side of the front panel of YFGW610.

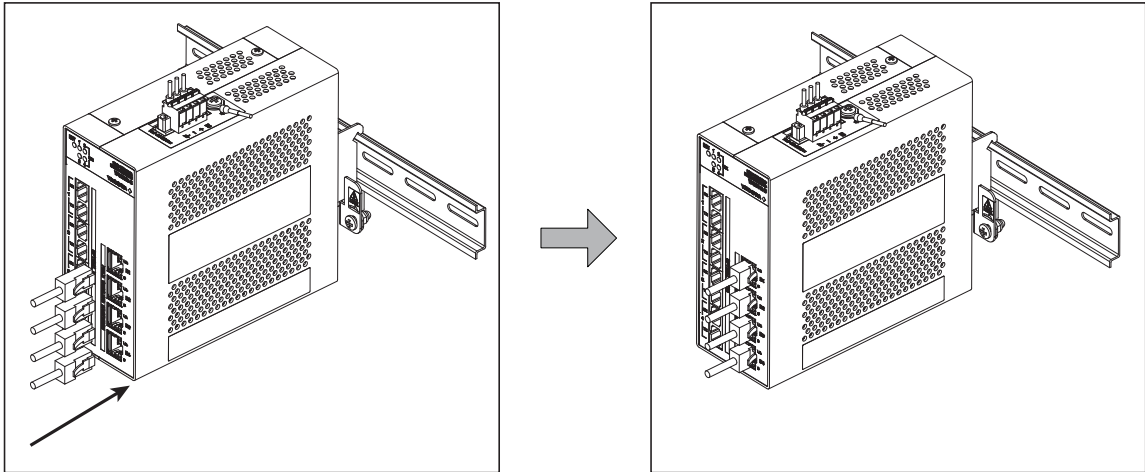

FB0406

Figure B4-6 Metal network wiring

■ Optical network (YFGW510/YFGW520 side) wiring

To the optical network interface (YFGW510/YFGW520 side) on the left side of the front face of YFGW610, connect an optical network cable conforming to the 100BASE-FX standard, terminated with a SC connector.

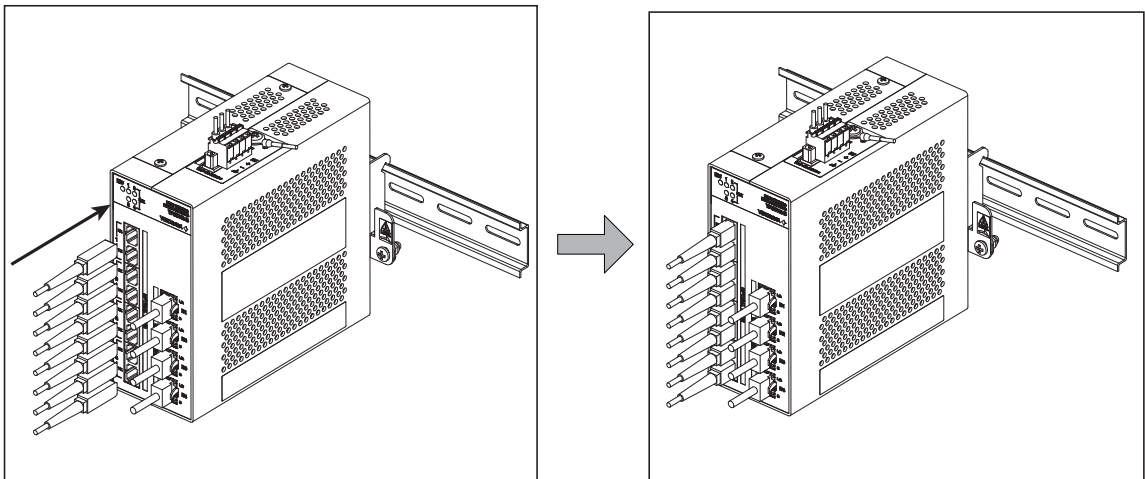

FB0407

Figure B4-7 Optical network wiring

B5. Explosion Protected Wiring

Be sure to read the precautions for the explosion protected type product including wiring described in “YFGW610 Field Wireless Media Converter Read Me First (IM 01W02D02-11EN)”.

B6. Settings

There are no setting elements in YFGW610. After properly wiring the power supply, ground and network cable, turn on YFGW610.

If the RDY display does not turn green, see C. Maintenance.

Part-C. Maintenance

Details of routine maintenance, addition, or replacement of YFGW610 are described in “E. Maintenance” of the User’s Manual of YFGW410 (IM 01W02D01-01EN); read that document first.

C1. Routine Maintenance

Check whether there are any alarms or abnormal information in any host system that monitors the status of field wireless devices, and if any information on device errors is displayed on the Field Wireless Management Console. Although the device information of YFGW610 is not displayed on the console, communication errors in other devices may be due to malfunction of YFGW610.

For checking procedures or troubleshooting, see “E. Maintenance” of the User’s Manual of YFGW410 (IM 01W02D01-01EN).

For YFGW610 maintenance, check the device installation status as well as the operation status of field wireless system components.

Check the installation status of YFGW610, power supply cable and network cable connection status, and stain status.

If YFGW610 becomes dirty or dusty, wipe with a soft cloth moistened with water or mild soap.

C2. Adding and replacing devices

For details on how to add or replace devices, see “E. Maintenance” of the User’s Manual of YFGW410 (IM 01W02D01-01EN).

C3. Maintenance in Hazardous Area



NOTE

Please be sure to read “YFGW610 Field Wireless Media Converter Read Me First (IM01W02D02-11EN)” for the precautions including maintenance and repair of the explosion-protected type product.

To carry out maintenance, check the power supply, ground and network cable for looseness.

Explosion protected instruments must retain their intended properties before and after maintenance. Otherwise, hazardous conditions can arise. Be sure to consult with Yokogawa for any repair and alteration.

For other field wireless network components, see the User’s Manual of the relevant device.

C4. Parts with Defined Life Spans

YFGW610 does not include any parts with defined life spans, which need to be replaced.

Read the following descriptions of parts with defined life spans.



NOTE

Notes regarding parts with defined life spans

- The term “Parts with defined life spans” refers to parts that are expected to wear out or break down within 10 years from the initial use under normal use and storage. Therefore, parts with expected life spans of 10 or more years are excluded here.
 - The recommended replacement cycle is the cycle indicated for preventive maintenance. It provides no guarantee against the accidental failures.
 - The recommended replacement cycle is merely a guideline. The actual replacement cycle depends on the usage status (ambient temperature, ambient atmosphere).
 - The recommended replacement cycle is subject to change according to the actual results in the field and other factors.
-

Part-D. Troubleshooting

This section describes the troubleshooting procedures to follow when a malfunction is identified in YFGW610 by the investigation described in “F1. Field Wireless System” in YFGW410 User’s Manual (IM 01W02D01-01EN).

On the front face of YFGW610, there are five status indicator LEDs (RDY, LINK-1, LINK-2, LINK-3, and LINK-4), and four pairs of LEDs (Link/ACT and Speed) in RJ-45 connectors.

■ Displaying the status of YFGW610

The relation between the status of the RDY LED and the status of YFGW610 is as follows.

Table D-1 Relation between the status of RDY LED and the status of YFGW610

LED	Power off	Starting up	Normal	Abnormal
RDY	OFF	Orange	Green	Red

If this LED is lit in red or off while energizing, YFGW610 may be broken. Replace the product.

■ Communication status

Other LEDs indicate the status of each communication interface. If any LED indicates abnormal status, check the wiring and the housing. If there is any problem in YFGW610, replace it.

Part-E. Specifications

E1. Standard Specification

■ COMMUNICATION INTERFACE

ITEM		Field Wireless Back-bone Specifications	Optical Network Specifications	
Communication Interface	Standard	100BASE-TX *1	100BASE-FX *2	
	Transmission Speed	100 Mbps	100 Mbps	
	Connector	RJ-45	SC connector [1pole x 2]	
	Cable Type	Category 5	Multimode Fiber *3	Single mode Fiber *4
	Wavelength	–	1300nm	
	Maximum Length	100 m	2000 m	5000 m
	Number of Ports	4 ports	4 ports	
	Port Name	B1, B2, B3, B4	1, 2, 3, 4	
	Protection	Surge	–	
	Port Connection	B1-1, B2-2, B3-3, B4-4 (fixed)		

*1: Connected to YFGW410.

*2: Connect to YFGW510/YFGW520. In outdoor wiring, it is recommended to use optical fiber cables with a nonmetallic tension member.

*3: Core diameter / cladding diameter 50/125 μm core or 62.5 / 125 μm can be used.

*4: ITU-T G.652 compliant products can be used.

■ Installation Environment

Temperature Range:

Operating: -40 to +65°C (altitude : up to 3000 m)

Storage: -40 to +85°C

Humidity Range:

Operating: 5 to 95 %RH (non-condensation)

Storage: 5 to 95 %RH (non-condensation)

Temperature gradient:

Operating: ±10°C/h or less

Storage: ±20°C/h or less

Power Supply:

Rated voltage : 24 V DC

Voltage Range *1 : 10.8 to 26.4 V DC

*1: The equipment shall not be operated outside the range.

Momentary Power Failure : Instant Disconnection

DC Power Supply Ripple Ratio : 1%_{p-p} or less

Power Dissipation:

Max. 10 W

Degrees of Protection:

IP20

Vibration resistance:

0.15 mm P-P (5~58 Hz), 1 G (58~150 Hz)

Shock resistance:

15 G 11 ms (de-energized, with half-sine wave pulse in three directions)

Noise resistance:

Electric field : 3 V/m or less (80 MHz~1 GHz)

Electrostatic discharges: 4 kV or less (contact discharge), 8 kV or less (aerial discharge)

Grounding:

Class D grounding with the grounding resistance of 100 Ω or less is necessary. (no sharing ground with others)

Cooling:

Natural Air Cooling

■ Regulatory Compliance Statements

CE Conformity:

- EMC Directive: EN 61326-1 Class A Table 2, EN 55011 Class A Group 1, EN 61000-6-2

- RoHS Directive: EN 50581

- Other Normative Standards: EN 61010-1 (Indoor use only) EN 60825-1 *1

*1: This standard is only applied to the product whose suffix of Output signal is -C.

Safety Requirements:

CSA-C22.2 No. 61010-1 (Indoor use only)

■ Physical Specifications

Housing Material:

Aluminum alloy plate with polyester, mint-green paint (Munsell 5.6BG 3.3/2.9 or its equivalent)

External Dimension:

150 x 60 x 140 mm (not include projection)

Weight:

Approx. 1.0 kg

Mounting:

DIN RAIL Mounting

E2. Model and Suffix Codes

MODEL AND SUFFIX CODES

Model	Suffix Code		Descriptions
YFGW610		Field Wireless Media Converter
General Specifications	Output signal	-B	100BASE-FX(Multimode Fiber)
		-C	100BASE-FX(Single mode Fiber) *1
	Manual Language	0	Japanese
		1	English
	Mounting Bracket	D	DIN RAIL Mounting
—	A	Always A	
—	A	Always A	
Option Codes	/□ Optional Specifications		

*1: Only applicable for connection with YFGW520.

OPTIONAL SPECIFICATIONS (For Explosion Protected Types)

Item	Specification	Code
Factory Mutual (FM)	Nonincendive Approval *1	—
ATEX	Type n declaration *2 Applicable Standard: EN 60079-0: 2012+A11:2013, EN 60079-15:2010 II 3 G Ex nA IIC T4 Gc X Amb. Temp.(Tamb): -40 to 65°C Altitude: up to 3000 m	KN27
Canadian Standards Association (CSA)	Nonincendive Approval *1	—
IECEX	Type n Approval *2	—

*1: To be compliant with these standards, the YFGW610 hardware needs to be installed in a lockable metal cabinet.

*2: To be compliant with these standards, the YFGW610 hardware needs to be installed in a lockable metal cabinet of IP54 or higher protection rating.

E3. External Dimensions

Unit : mm (approx. inch)

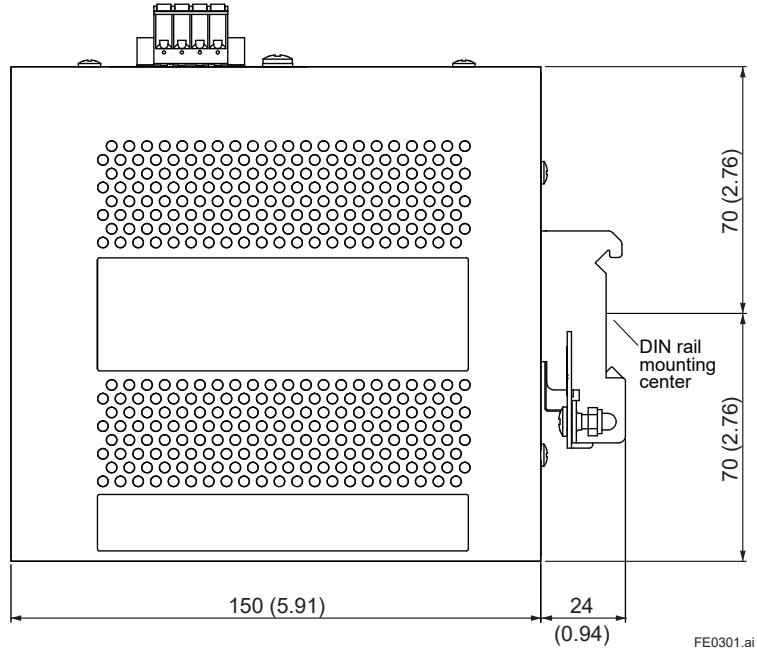
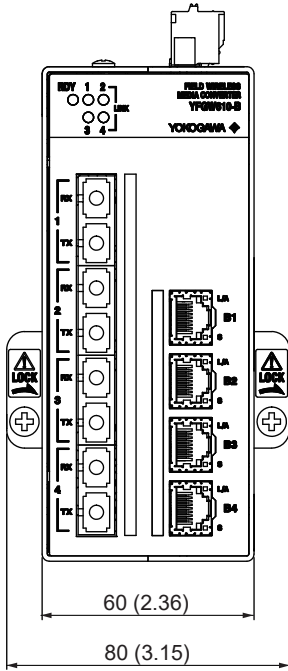
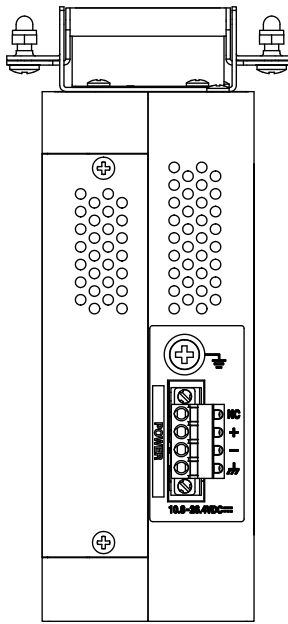

FE0301.ai