

Please read through this User's Manual before use for correct handling.
Please keep this User's Manual for future reference.

CAUTIONARY NOTES FOR SAFE USE OF THE PRODUCT

This User's Manual should be carefully read before installing and operating the product. Please keep this User's Manual for future reference. The related manuals and general specifications are shown in the table below.

Doc. Name	Doc. Number
Model MA7D Distributor (User's Manual)	IM 77J04A07-02E (This manual)
Model MA7D Distributor (General Specifications)	GS 77J04A07-02E

User's manuals in the above table are essential parts of the product; keep it in a safe place for future reference.

This manual is intended for the following personnel;

- Engineers responsible for installation, wiring, and maintenance of the equipment.
- Personnel responsible for normal daily operation of the equipment.

The following symbol is used on the product and in this manual to ensure safe usage.



WARNING

Calls attention to actions or conditions that could cause serious or fatal injury to the user, and indicates precautions that should be taken to prevent such occurrences.



CAUTION

Calls attention to actions or conditions that could cause injury to the user or damage to the instrument or property and indicates precautions that should be taken to prevent such occurrences.

CHECKING PRODUCT SPECIFICATIONS AND PACKAGE

(1) Checking the Model and Product Specifications

Check that the model and specifications indicated on the nameplate attached to the main unit are as ordered.

(2) Packaged Items

Check that the packing carton contains the following items:

- MA7D: 1
- Spacer (used for DIN rail mounting): 1
- User's Manual (this manual: IM 77J04A07-02E): 1 copy

GENERAL

This plug-in type distributor is used in combination with a two-wire type transmitter to convert the transmitter's 4 to 20 mA DC signals into 4 to 20 mA DC current or 1 to 5 V DC voltage signals.

MODEL AND SUFFIX CODES

Model	Suffix codes	Description
MA7D	-A x x -x /x	Distributor
Input signal	-A	4 to 20 mA DC Transmitter power supply: 25.25±0.25 V DC
Output-1 signal	A 6	4 to 20 mA DC 1 to 5 V DC
Output-2 signal	A 6	4 to 20 mA DC 1 to 5 V DC
Power supply	-3	24 V DC ±10%
	-4	100-130 V AC/DC *1
	-5	200-240 V AC *2
Option	/SN	No socket (with socket if not specified)
	/CO	Coating
	/FB	Fuse bypass

*1 Operating range: 85 to 150 V AC/DC

*2 Operating range: 170 to 264 V AC

1. MOUNTING METHOD



CAUTION

- Plug/disconnect the main unit into/from the socket vertically to the socket face. Otherwise the terminals may bend and it may cause bad contact.
- The converter shall not tilt 5 degrees or more in either direction when installed.
- When the converter is not connected to the socket, it is necessary to protect the socket against ingress of dust to the connector part.
- Keep this product in a conductive bag when plugged out, during transport or storage.

1.1 Wall Mounting

Remove the stoppers (top and bottom) from the product and pull out the main unit from the socket. Fix the socket on the wall using two M4 screws. Next, insert the main unit into the socket and fasten the main unit with the stoppers (top and bottom).

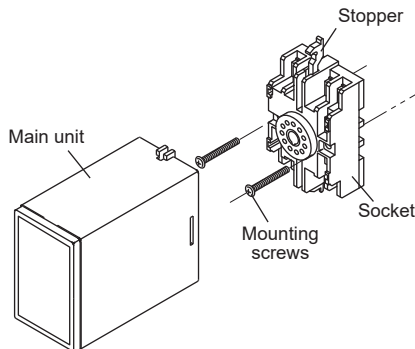

<Mounting Dimensions>

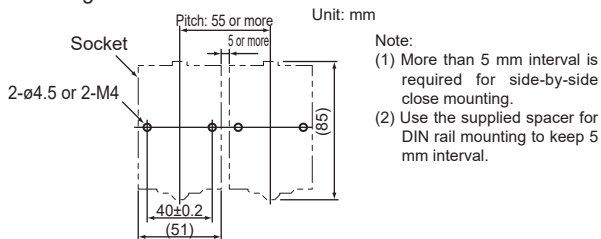

1.2 DIN Rail Mounting

Insert a DIN rail into the upper part of the DIN rail groove on the rear of the socket, and then slide the slide lock at the lower part of the socket upwards until the socket is fixed into position as shown below.

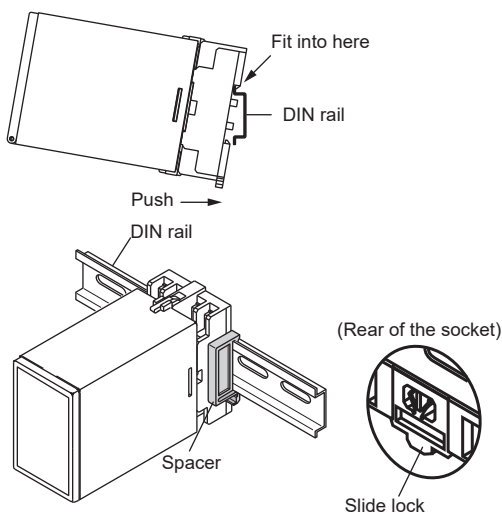

1.3 Using a Duct

When using a wiring duct, install the duct at least 20 mm away from the top and bottom faces of the main unit.

2. INSTALLATION LOCATIONS

- Avoid the following environments for installation locations: Areas with vibrations, corrosive gases, dust, water, oil, solvents, direct sunlight, radiation, a strong electric field, and/or a strong magnetic field, direct radiant heat, wind, temperature fluctuation, 2000 m or more above sea level.
- If there is any risk of a surge being induced into the power line and/or signal lines due to lightning or other factors, a dedicated lightning arrester should be used as protection for both this unit and a field-installed device.
- Operating temperature/humidity range: 0 to 50°C (0 to 40°C for multiple mounting)/5 to 90%RH (no condensation)
 - * If the previous model (style S3.xx earlier) is installed together, the ambient temperature is 0 to 40°C.
- Continuous vibration: (at 5 to 9 Hz) Half amplitude of 3 mm or less (at 9 to 150 Hz) 9.8m/s² or less, 1 oct/min for 90 minutes each in the three axis directions
- Impact: 98 m/s² or less, 11 ms, 3 axes, 6 directions, 3 times each
- Install in a place where rigidity is secured.

3. EXTERNAL WIRING



WARNING

- To avoid the risk of an electric shock, turn off the power supply and use a tester or similar device to ensure that no power is supplied to a cable to be connected, before carrying out wiring work.
- Do not operate the product in the presence of flammable or explosive gases or vapors. To do so is highly dangerous.
- Use of the product ignoring the specifications may cause overheating or damage. Before turning on the power, ensure the following:
 - Power supply voltage and input signal value applied to the product should meet the required specifications.
 - The external wiring to the terminals and wiring to ground are as specifications.

Wiring should be connected to the terminals on the socket of the product. The terminals for external connections are of M3.5 screws. Use crimp-on terminal lugs for connections to the terminals.

- Recommended cables: A nominal cross-sectional area of 0.5 mm² or thicker for signal cables, and that of 1.25 mm² or thicker for power cables.

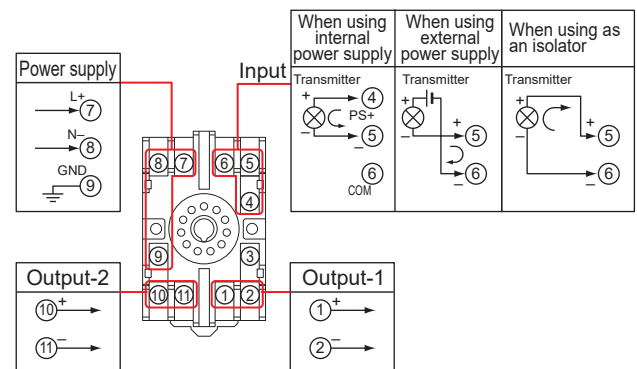

CAUTION

- The power line and input/output signal lines should be installed away from noise-generating sources. Other wise accuracy cannot be guaranteed.
- Make sure to earth ground the ground terminal through minimum resistance. The length and thickness of the grounding cable should be as short and thick as possible. Directly connect the lead from the ground terminal (terminal no. 9) of the product to the ground. Do not carry out daisy-chained inter-ground terminal wiring.
- The product is sensitive to static electricity; exercise care in operating it. Before you operate the product, touch a nearby metal part to discharge static electricity.

4. PART NAMES OF FRONT PANEL

The figure below shows the MA7D with its front panel (cover) being open.

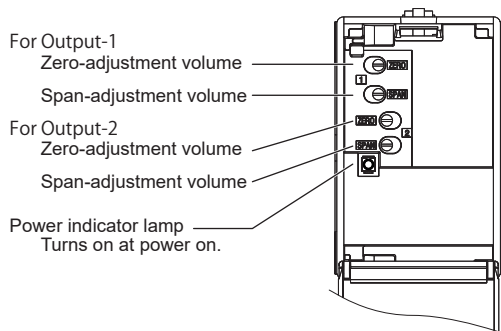

5. MAINTENANCE

The product starts running immediately when the power is turned on; however, it needs 10 to 15 minutes of warm-up before it meets the specified performance.

5.1 Calibration Apparatus

- A DC voltage/current standard (Yokogawa GS200 or the equivalent)
- A digital multimeter (Yokogawa DM7560 or the equivalent)
- A precision resistor of $250\ \Omega \pm 0.01\%$, 1 W

5.2 Calibration Procedure

- (1) Connect the instruments as shown below. First adjust the output-1 signal and then the output-2 signal.
 - (2) Use the DC voltage/current standard and apply input signals equivalent to 0, 25, 50, 75, and 100% of the input span to the product. Check to see the corresponding output voltages are 0, 25, 50, 75, and 100% respectively and within the specified accuracy rating. "R" is used for current output.
- If the output signals are out of the accuracy rating range, adjust the output signal level using the zero and span adjustment volumes on front face of the product.

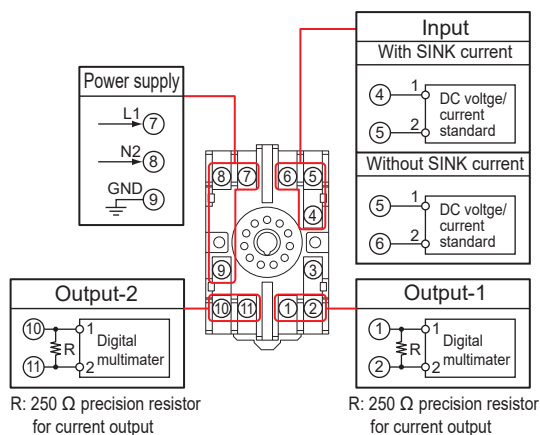

6. TRANSPORT AND STORAGE CONDITIONS

- Temperature: -25 to 70°C
- Temperature change rate: 20°C per hour or less
- Humidity: 5 to 95%RH (no condensation)



CAUTION

Keep this product in a conductive bag when plugged out, during transport or storage.

