

Customer Maintenance Parts List

EJX510A, EJX530A, EJX610A, and EJX630A Absolute and Gauge Pressure Transmitters

DPharp **EJX**™

• Applicable models and style code

Models	Style code
EJX510A, EJX530A	S2
EJX610A, EJX630A	S1

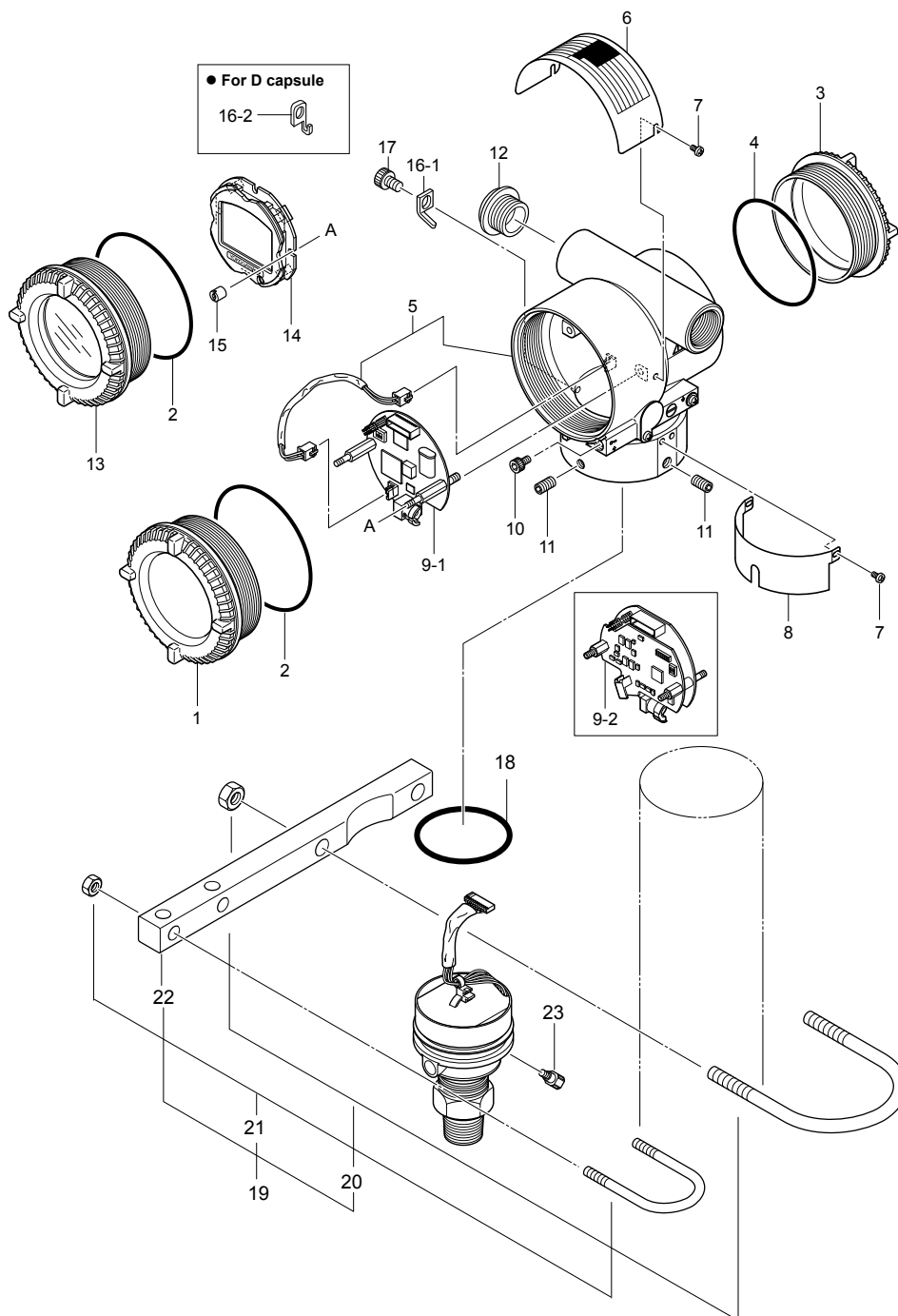

Item	Part No.	Qty	Description
1	Below F9913TJ F9913VP F9913SC F9913SD F9913CJ F9913DP	1	Cover (Note 1) Cast-aluminum alloy Cast-aluminum alloy (Option code /PR) ASTM CF-8M ASTM CF-8M (Option code /PR) Cast-aluminum alloy with corrosion resistance properties Cast-aluminum alloy with corrosion resistance properties (Option code /PR)
2	Below F9341JP F9900GS	1	O-ring Buna-N Fluoro-rubber (Option code /HE)
3	Below F9913TA F9913VF F9913SA F9913SB F9913CA F9913DF	1	Cover (Note 1) Cast-aluminum alloy Cast-aluminum alloy (Option code /PR) ASTM CF-8M ASTM CF-8M (Option code /PR) Cast-aluminum alloy with corrosion resistance properties Cast-aluminum alloy with corrosion resistance properties (Option code /PR)
4	Below F9910LE F9900GR	1	O-ring Buna-N Fluoro-rubber (Option code /HE)
5	—	1	Case Assembly for amplifier housing code 1 (see Table 1 and Table 2)
6	—	1	Name Plate
7	Below F9900RG F9900RR F9900RE	4	Screw For cast-aluminum alloy case assembly, 316 SST For ASTM CF-8M case assembly, 316 SST
8	F9900RE	1	Tag Plate, 316 SST
9-1	Below F9920BE F9920BC F9920BN F9920BM	1	CPU Assembly (Note 2) For BRAIN protocol version For BRAIN protocol version (Option code /AL) For HART 5/7 protocol version (Note 3) (Note 4) For HART 5/7 protocol version (Option code /AL) (Note 3) (Note 4)
9-2	Below F9921AB	1	CPU Assembly (Note 2) For FOUNDATION Fieldbus protocol version with the device revision 5 (Note 4) (Note 5)
10	F9900RP	2	Bolt for Option code /KF22, /KU22, /SF2, /SU2, /NF2, or /JF3
11	Below F9900GC F9900RH	2	Screw SUSXM7 316 SST (for ASTM CF-8M case assembly, or Option code /HC)
12	Below F9900GQ F9900GY F9900GP F9900GX G9612EB F9900GL F9900GK F9900GN	1	Plug For G1/2, Cast-aluminum alloy For G1/2, Cast-aluminum alloy, option code /HE For M20, Cast-aluminum alloy For M20, Cast-aluminum alloy, option code /HE For 1/2 NPT, 304 SST For G1/2, 316 SST For M20, 316 SST For 1/2 NPT, 316 SST
13	Below F9913JA F9913JX F9913KA F9913KX F9913JZ F9913JY F9913KZ F9913KY F9913GA F9913GX F9913HA F9913HX	1	Cover Assembly (Note 1) Cast-aluminum alloy Cast-aluminum alloy (Option code /PR) Cast-aluminum alloy (Option code /HE) Cast-aluminum alloy (Option code /PR and /HE) ASTM CF-8M ASTM CF-8M (Option code /PR) ASTM CF-8M (Option code /HE) ASTM CF-8M (Option code /PR and /HE) Cast-aluminum alloy with corrosion resistance properties Cast-aluminum alloy with corrosion resistance properties, option code /PR Cast-aluminum alloy with corrosion resistance properties, option code /HE Cast-aluminum alloy with corrosion resistance properties, option code /PR and /HE
14	Below F9920LU F9920LV	1	LCD Board Assembly Without range-setting switch With range-setting switch
15	F9342MK	2	Mounting Screw

} For integral indicator

(Note 1) Not applicable for option code /X2.

(Note 2) Applicable for general use type. In case of explosionproof type, consult Yokogawa local office.

(Note 3) This CPU assembly is available for both HART protocol revisions, but is shipped with setting of HART protocol revision 5.
Change the revision number by editing the parameter before using it when HART protocol revision 7 is required.

(Note 4) Not applicable for option code /DG1, /DG6, or /EE.

(Note 5) Not applicable for the device revision 4 or earlier.

Item	Part No.	Qty	Description
16-1	F9900GE	1	Plate (for A, B, or C capsule), 316 SST
16-2	F9940WG	1	Hook (for D capsule), 316 SST
17	F9900RJ	1	Bolt, 316 or 316L SST
18	Below F9900GH F9900GT	1	O-ring Buna-N Fluoro-rubber O-ring, option code /HE
19	F9900SJ	1	Bracket Assembly, 316 SST and ASTM CF-8M
20	F9900SN	1	U-Bolt/Nut Assembly, 316 SST
21	F9900SK	1	U-Bolt/Nut Assembly, 316 SST
22	F9900SF	1	Bracket, ASTM CF-8M
23	F9940WF	1	Pipe Assembly (for A, B, or C capsule)

■ Case Assembly Part Number *1

● For BRAIN or HART protocol version

Table 1. Case Assembly Parts Number (Item 5)

Description		Electrical Connection	Case Assembly Part Number (Item 5)			
			G1/2 1 pc.	G1/2 2 pcs.	1/2NPT 2 pcs.	M20 2 pcs.
Without Lightning Protector	Without Status Output		F9918JA	F9918LA	F9918NA	F9918QA
	With Status Output (Option code /AL)		F9918JB	F9918LB	F9918NB	F9918QB
With Lightning Protector (Option code /A)	Without Status Output		F9318JC	F9318LC	F9318NC	F9318QC
	With Status Output (Option code /AL)		F9918JD	F9918LD	F9918ND	F9918QD

● For FOUNDATION Fieldbus protocol version

Table 2. Case Assembly Parts Number (Item 5)

Description		Electrical Connection	Case Assembly Part Number (Item 5)			
			G1/2 1 pc.	G1/2 2 pcs.	1/2NPT 2 pcs.	M20 2 pcs.
Without Lightning Protector			F9918KA	F9918MA	F9918PA	F9918RA
With Lightning Protector (Option code /A)			F9918KC	F9918MC	F9918PC	F9918RC

*1: Applicable for general use type. In case of explosionproof type, consult Yokogawa local office.
Not applicable for Option code /X2, /HE, or /HC.