

EJX910A and EJX930A Multivariable Transmitters

IM 01C25R01-01E



EJX910A and EJX930A

Multivariable Transmitters

IM 01C25R01-01E 19th Edition

Contents

1.	Introduction.....	1-1
	■ Regarding This Manual.....	1-2
	■ Trademarks	1-2
1.1	Safe Use of This Product	1-3
1.2	Warranty.....	1-4
2.	About the EJX Multivariable Transmitter.....	2-1
2.1	Features	2-1
2.2	Initial Check and Installation Procedure	2-1
2.3	Flow Calculation (except Modbus Communication Type)	2-3
2.4	Auto Compensation Mode (except Modbus Communication Type).....	2-3
	2.4.1 Configuration Procedure for Auto Compensation Mode	2-4
2.5	Basic Mode (except Modbus Communication Type)	2-4
	2.5.1 Configuration Procedure for Basic Mode	2-6
	2.5.2 Calculation of the Basic mode parameters.....	2-7
3.	Handling Cautions.....	3-1
3.1	Model and Specifications Check.....	3-1
3.2	Unpacking.....	3-1
3.3	Storage	3-2
3.4	Selecting the Installation Location	3-2
3.5	Pressure Connection.....	3-2
3.6	Waterproofing of Cable Conduit Connections	3-2
3.7	Restrictions on Use of Radio Transceivers	3-3
3.8	Insulation Resistance and Dielectric Strength Test.....	3-3
3.9	Installation of an Explosion-Protected Instrument	3-3
	3.9.1 FM Approval.....	3-4
	3.9.2 CSA Certification.....	3-5
	3.9.3 ATEX Certification.....	3-6
	3.9.4 IECEx Certification.....	3-8
3.10	EMC Conformity Standards.....	3-10
3.11	Pressure Equipment Directive (PED)	3-10
3.12	Safety Requirement Standards	3-11
3.13	EU-RoHS Directive	3-11

4.	Component Names	4-1
5.	Installation.....	5-1
5.1	Precautions	5-1
5.2	Mounting	5-1
5.2.1	How to install the position adjustable bracket.....	5-2
5.3	Changing the Process Connection.....	5-4
5.4	Swapping the High/Low-pressure Side Connection.....	5-4
5.4.1	Rotating Pressure-detector Section 180°	5-4
5.4.2	Using the Communicator	5-5
5.5	Rotating Transmitter Section.....	5-5
5.6	Changing the Direction of Integral Indicator	5-6
6.	Installing Impulse Piping	6-1
6.1	Impulse Piping Installation Precautions	6-1
6.1.1	Connecting Impulse Piping to a Transmitter.....	6-1
6.1.2	Routing the Impulse Piping.....	6-2
6.2	Impulse Piping Connection Examples	6-4
7.	Wiring.....	7-1
7.1	Wiring Precautions	7-1
7.2	Selecting the Wiring Materials.....	7-1
7.3	Types of Output.....	7-1
7.4	Connection	7-2
7.4.1	Power Supply Wiring Connection	7-2
7.4.2	External Indicator Connection	7-2
7.4.3	Communicator Connection.....	7-2
7.4.4	Check Meter Connection	7-2
7.4.5	External Temperature Connection.....	7-2
7.5	Wiring	7-3
7.5.1	Loop Configuration	7-3
7.5.2	Wiring Installation.....	7-4
7.6	RTD Cable Connection	7-5
7.6.1	Connecting Shielded Cable with Cable Gland (External temperature input code: -1, -2, -3, and -4)	7-5
7.6.2	Connecting Shielded Cable for Conduit Use (External temperature input code: -B, -C, and -D).....	7-8
7.6.3	Removing Shielded Cable with Cable Gland (External temperature input code: -1, -2, -3, and -4)	7-8
7.6.4	Removing Shielded Cable for Conduit Use (External temperature input code: -B, -C, -D).....	7-8
7.6.5	Cable Connection RTD Terminal Box Side.....	7-9
7.7	Grounding.....	7-9

8.	Operation	8-1
8.1	Preparation for Starting Operation	8-1
8.2	Zero Point Adjustment	8-2
8.2.1	Adjusting Zero Point for Differential Pressure	8-2
8.2.2	Adjusting Zero Point for Static Pressure.....	8-3
8.2.3	Adjusting Zero Point for External Temperature.....	8-3
8.3	Starting Operation	8-4
8.4	Shutting Down the Transmitter	8-4
8.5	Venting or Draining Transmitter Pressure-detector Section	8-4
8.5.1	Draining Condensate	8-5
8.5.2	Venting Gas.....	8-5
9.	Maintenance	9-1
9.1	Overview	9-1
9.2	Calibration Instruments Selection	9-1
9.3	Calibration	9-1
9.3.1	Pressure and Static Pressure	9-1
9.3.2	External Temperature (RTD).....	9-2
9.4	Disassembly and Reassembly	9-3
9.4.1	Replacing the Integral Indicator	9-4
9.4.2	Replacing the CPU Board Assembly	9-5
9.4.3	Cleaning and Replacing the Capsule Assembly	9-5
9.4.4	Replacing the Process Connector Gaskets.....	9-7
9.4.5	Cleaning/replacing the bug screen(Option Code /BS)	9-7
9.5	Troubleshooting.....	9-8
9.5.1	Basic Troubleshooting	9-8
9.5.2	Troubleshooting Flowcharts.....	9-9
9.5.3	Alarms and Countermeasures.....	9-11
10.	General Specifications	10-1

Revision Information

1. Introduction

Thank you for purchasing the DPharp EJX multivariable transmitter.

Your EJX multivariable Transmitter was precisely calibrated at the factory before shipment. To ensure both safety and efficiency, please read this manual carefully before you operate the instrument.



NOTE

- This manual mainly describes the hardware configurations of EJX multivariable transmitter. For information on the software configuration and operation, please refer to IM 01C25R02-01E for the HART communication type, IM 01C25R03-01E for FOUNDATION Fieldbus communication type and IM 01C25R05-01EN for Modbus communication type. When using the EJX multivariable transmitter for the Safety Instrumented System application, please refer to the Appendix 1 of HART communication manual (IM 01C25R02-01E) and follow the instructions and procedures described there.

For the specifications, external dimensions, and model, suffix and option codes of each product, please refer to the General Specifications sheet as listed below.

To ensure correct use of this instrument, read both the hardware and software manuals thoroughly before use. All the documents as listed below can be downloaded from the website of Yokogawa. (Website address: <https://www.yokogawa.com/solutions/products-platforms/field-instruments/>)

- This manual covers the EJX910A and EJX930A multivariable transmitter, whose style codes are as described in the following table. Unless otherwise stated, the illustrations in this manual are of the EJX910A multivariable transmitter. Users of the EJX930A should bear in mind that certain features of their instrument will differ from those shown in the illustrations of the EJX910A.

Model	Style code
EJX910A	S2
EJX930A	S1

Instruction manuals for EJX Multivariable transmitters are composed of the following documents.

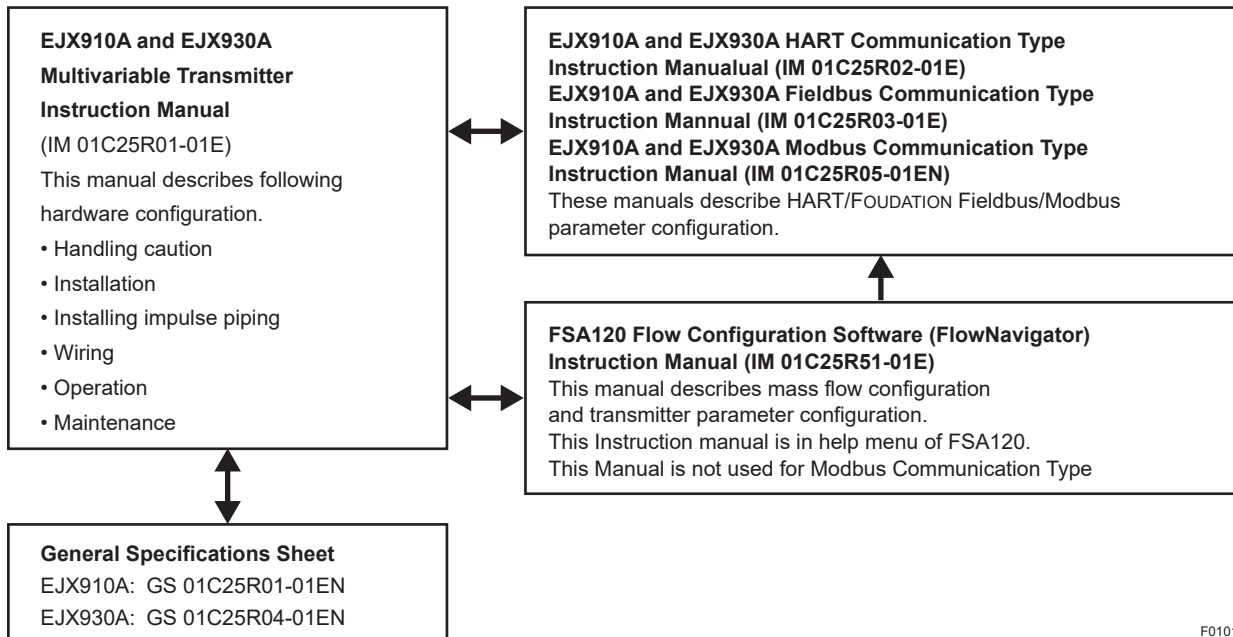

F0101.ai

■ Regarding This Manual

- This manual should be provided to the end user.
- This manual and the identification tag attached on the packing box are essential parts of the product. Please keep them in a safe place for future reference.
- The contents of this manual are subject to change without prior notice.
- All rights reserved. No part of this manual may be reproduced in any form without Yokogawa’s written permission.
- Yokogawa makes no warranty of any kind with regard to this manual, including, but not limited to, implied warranty of merchantability and fitness for a particular purpose.
- If any question arises or errors are found, or if any information is missing from this manual, please inform the nearest Yokogawa sales office.
- The specifications covered by this manual are limited to those for the standard type under the specified model number break-down and do not cover custom-made instruments.
- Please note that changes in the specifications, construction, or component parts of the instrument may not immediately be reflected in this manual at the time of change, provided that postponement of revisions will not cause difficulty to the user from a functional or performance standpoint.
- Yokogawa assumes no responsibilities for this product except as stated in the warranty.
- If the customer or any third party is harmed by the use of this product, Yokogawa assumes no responsibility for any such harm owing to any defects in the product which were not predictable, or for any indirect damages.
- The following safety symbols are used in this manual:



WARNING

Indicates a potentially hazardous situation which, if not avoided, could result in death or serious injury.



CAUTION

Indicates a potentially hazardous situation which, if not avoided, may result in minor or moderate injury. It may also be used to alert against unsafe practices.



IMPORTANT

Indicates that operating the hardware or software in this manner may damage it or lead to system failure.



NOTE

Draws attention to information essential for understanding the operation and features.

⎓ Direct current

⏏ Functional grounding terminal

■ Trademarks

- ‘DPharp’, ‘EJX’, ‘FieldMate’ and ‘FlowNavigator’ are registered trademarks of Yokogawa Electric Corporation. Company names and product names used in this material are registered trademarks or trademarks of their respective owners.
- In this manual, trademarks or registered trademarks are not marked with TM or ®.

1.1 Safe Use of This Product

For the safety of the operator and to protect the instrument and the system, please be sure to follow this manual's safety instructions when handling this instrument. If these instructions are not heeded, the protection provided by this instrument may be impaired. In this case, Yokogawa cannot guarantee that the instrument can be safely operated. Please pay special attention to the following points:

(a) Installation

- This instrument may only be installed by an engineer or technician who has an expert knowledge of this device. Operators are not allowed to carry out installation unless they meet this condition.
- With high process temperatures, care must be taken not to burn yourself by touching the instrument or its casing.
- Never loosen the process connector nuts when the instrument is installed in a process. This can lead to a sudden, explosive release of process fluids.
- When draining condensate from the pressure detector section, take appropriate precautions to prevent the inhalation of harmful vapors and the contact of toxic process fluids with the skin or eyes.
- When removing the instrument from a hazardous process, avoid contact with the fluid and the interior of the meter.
- All installation shall comply with local installation requirements and the local electrical code.

(b) Wiring

- The instrument must be installed by an engineer or technician who has an expert knowledge of this instrument. Operators are not permitted to carry out wiring unless they meet this condition.
- Before connecting the power cables, please confirm that there is no current flowing through the cables and that the power supply to the instrument is switched off.

(c) Operation

- Wait 5 min. after the power is turned off, before opening the covers.

(d) Maintenance

- Please carry out only the maintenance procedures described in this manual. If you require further assistance, please contact the nearest Yokogawa office.
- Care should be taken to prevent the build up of dust or other materials on the display glass and the name plate. To clean these surfaces, use a soft, dry cloth.

(e) Explosion Protected Type Instrument

- Users of explosion proof instruments should refer first to section 3.9 (Installation of an Explosion Protected Instrument) of this manual.
- The use of this instrument is restricted to those who have received appropriate training in the device.
- Take care not to create sparks when accessing the instrument or peripheral devices in a hazardous location.

(f) Modification

- Yokogawa will not be liable for malfunctions or damage resulting from any modification made to this instrument by the customer.

(g) Product Disposal

- The instrument should be disposed of in accordance with local and national legislation/regulations.

(h) Authorized Representative in EEA and the importer into the EU/EEA market

- In relation to the CE Marking, The authorised representative for this product in the EEA (European Economic Area) is:
Yokogawa Europe B.V.
Euroweg 2, 3825 HD Amersfoort, The Netherlands
and the importer for this product into the EU/EEA market via the YOKOGAWA sales channel is:
Yokogawa Europe B.V.
Euroweg 2, 3825 HD Amersfoort, The Netherlands

(i) Control of Pollution Caused by the Product

- This is an explanation for the product based on "Control of Pollution caused by Electronic Information Products" in the People's Republic of China.

電子情報製品汚染制御管理弁法 (中国版RoHS)

产品中有害物质或元素的名称及含量

型号	部件名称	有害物质					
		铅 (Pb)	汞 (Hg)	镉 (Cd)	六价铬 (Cr (VI))	多溴联苯 (PBB)	多溴二苯醚 (PBDE)
EJX/EJA-E/ EJA/EJA-A Series 差压 / 压力变送器	壳体	×	○	○	○	○	○
	膜盒组件	×	○	○	○	○	○
	基板组件	×	○	○	○	○	○
	电源连接线	×	○	○	○	○	○
○ : 表示该部件的所有均质材料中的有害物质的含量均在 GB/T26572 标准中所规定的限量以下。 × : 表示至少该部件的某些均质材料中的有害物质的含量均在 GB/T26572 标准中所规定的限量以上。							



环保使用期限 :

该标识适用于 SJ/T11364 中所述, 在中华人民共和国销售的电子电气产品的环保使用期限。

注) 该年数为“环保使用期限”, 并非产品的质量保证期。

1.2 Warranty

- The warranty shall cover the period noted on the quotation presented to the purchaser at the time of purchase. Problems occurring during the warranty period shall basically be repaired free of charge.
- If any problems are experienced with this instrument, the customer should contact the Yokogawa representative from which this instrument was purchased or the nearest Yokogawa office.
- If a problem arises with this instrument, please inform us of the nature of the problem and the circumstances under which it developed, including the model specification and serial number. Any diagrams, data and other information you can include in your communication will also be helpful.
- The party responsible for the cost of fixing the problem shall be determined by Yokogawa following an investigation conducted by Yokogawa.
- The purchaser shall bear the responsibility for repair costs, even during the warranty period, if the malfunction is due to:
 - Improper and/or inadequate maintenance by the purchaser.
 - Malfunction or damage due to a failure to handle, use, or store the instrument in accordance with the design specifications.
 - Use of the product in question in a location not conforming to the standards specified by Yokogawa, or due to improper maintenance of the installation location.
 - Failure or damage due to modification or repair by any party except Yokogawa or an approved representative of Yokogawa.
 - Malfunction or damage from improper relocation of the product in question after delivery.
 - Reason of force majeure such as fires, earthquakes, storms/floods, thunder/lightening, or other natural disasters, or disturbances, riots, warfare, or radioactive contamination.

2. About the EJX Multivariable Transmitter

This chapter gives an overview of the functions and the installation of the EJX Multivariable transmitter. For details on specific procedures, refer to the corresponding chapter.

2.1 Features

• Multi Sensing Function

The EJX multivariable transmitter has a Multi Sensing function that enables a single transmitter to measure differential pressure, static pressure, and external temperature. Mass flow measurement instruments can calculate and output the flow value using these three measured variables except Modbus Communication Type. The FSA120 flow configuration software (FlowNavigator) is used to configure mass flow calculation.

• Simultaneous Analog Output and Pulse Output (HART communication type)

The EJX multivariable transmitter has one analog output for the output of single measured variables. With digital communications, all of these variables can be output simultaneously.

In addition to analog output, pulse output is provided as a standard function of the EJX multivariable transmitter. It can perform both types of output simultaneously. Pulse output is used for total flow, flow rate, and alarm status.

2.2 Initial Check and Installation Procedure

Figure 2.2 is a flowchart showing the basic sequence for installing and wiring an EJX Multivariable Transmitter.

Refer to the specified chapter for the details of each procedure.

Flow configuration can be performed at the following stages:

- (1) On the bench, before installation.
- (2) In the field, after installation.



IMPORTANT

Before performing flow configuration in the field, make sure the installation location meets all safety requirements.

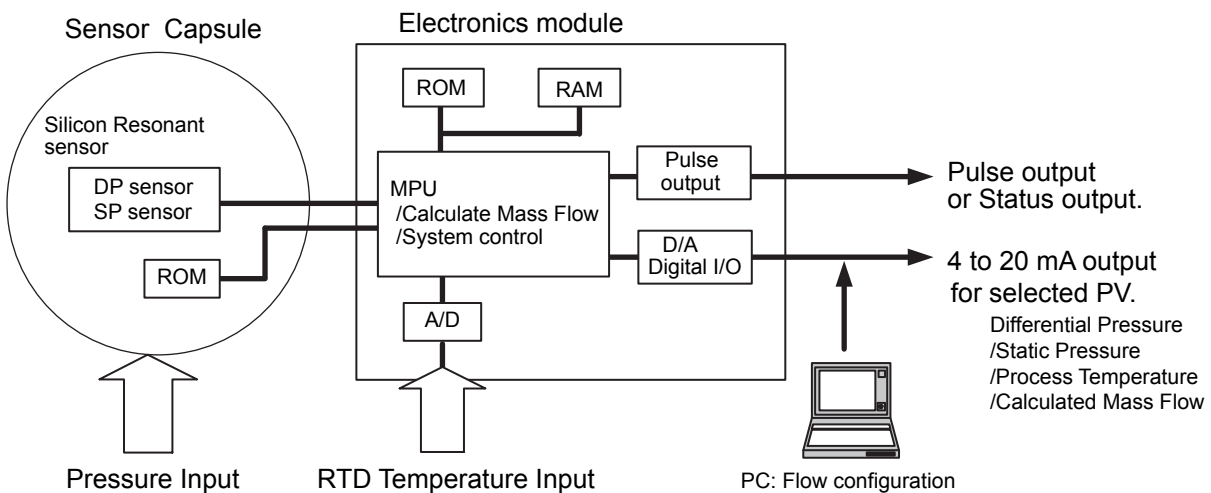
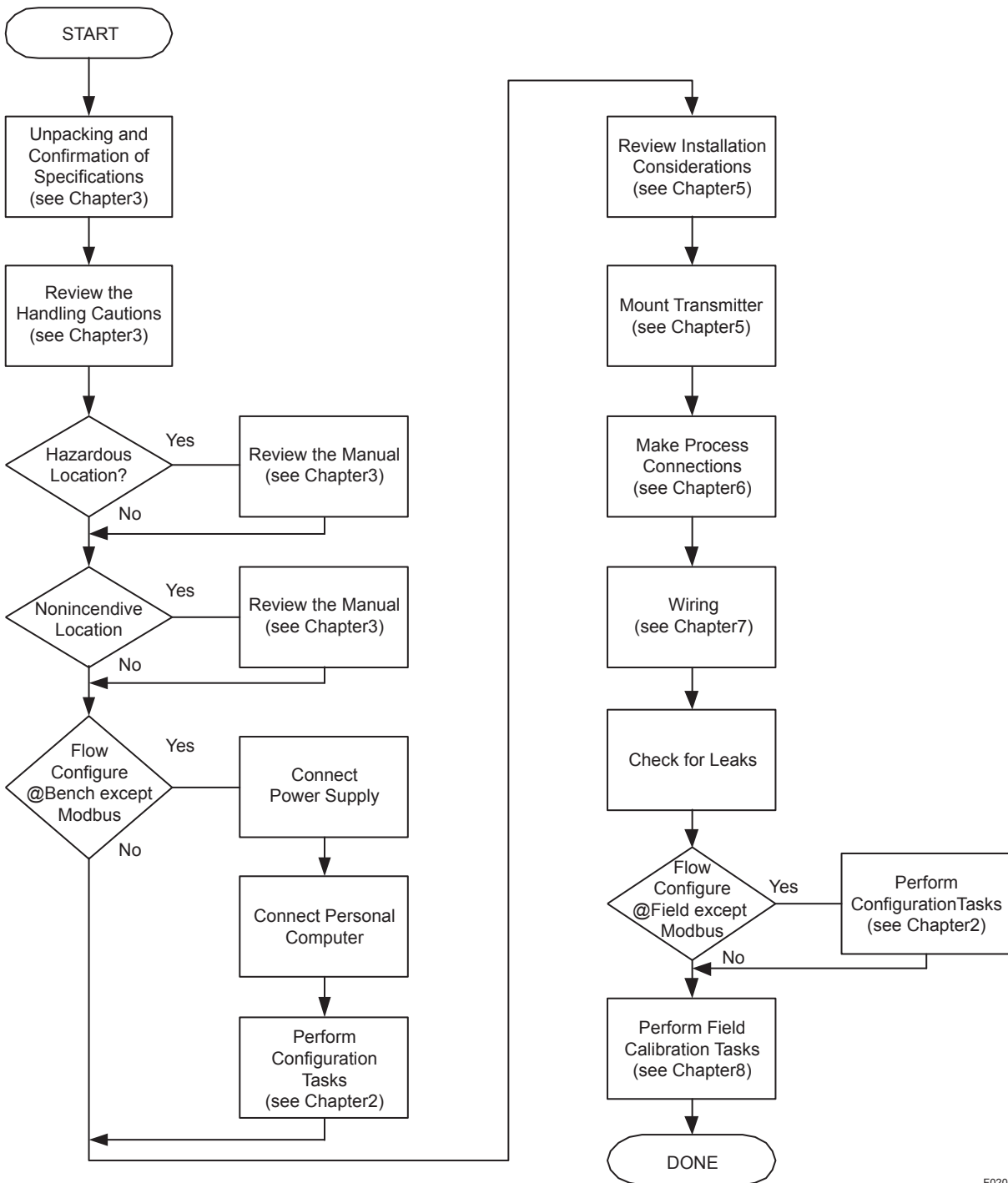

Figure 2.1 Block Diagram of EJX Multivariable Transmitter System (HART communication type)



F0202.ai

Figure 2.2 Installation Flowchart

2.3 Flow Calculation (except Modbus Communication Type)

There are two flow calculation modes: auto compensation mode and basic mode.

The FlowNavigator is required to configure auto compensation mode.
(Please refer to IM 01C25R51-01E for FSA120.)

Sections 2.4 and 2.5 give an overview of the two calculation functions and explain how to configure them.

2.4 Auto Compensation Mode (except Modbus Communication Type)

Configuration of the fluid physical properties and the primary device can be performed from an FlowNavigator dialog window. In auto compensation mode, all flow factors for flow calculation are dynamically compensated to an optimum value with a high level of accuracy. The flow factors that are automatically compensated are discharge coefficient, diameter of primary device, upstream internal pipe diameter, gas expansion factor, density, and viscosity.

Based Mass Flow Equation [In case of Orifice]

$$Q_m = \frac{C}{\sqrt{(1-\beta^4)}} \epsilon \frac{\pi}{4} d^2 \sqrt{2\Delta P \rho}$$

C, β, ε, d and ρ are dynamically compensated flow factor.

- Q_m: Mass Flow
- C: Discharge coefficient
- β: Diameter ratio
- ε: Expansion factor
- d: Diameter of primary device
- ΔP: Differential Pressure
- ρ: Density of fluid

Volume Flow Equation

$$Q_v = Q_m / \rho$$

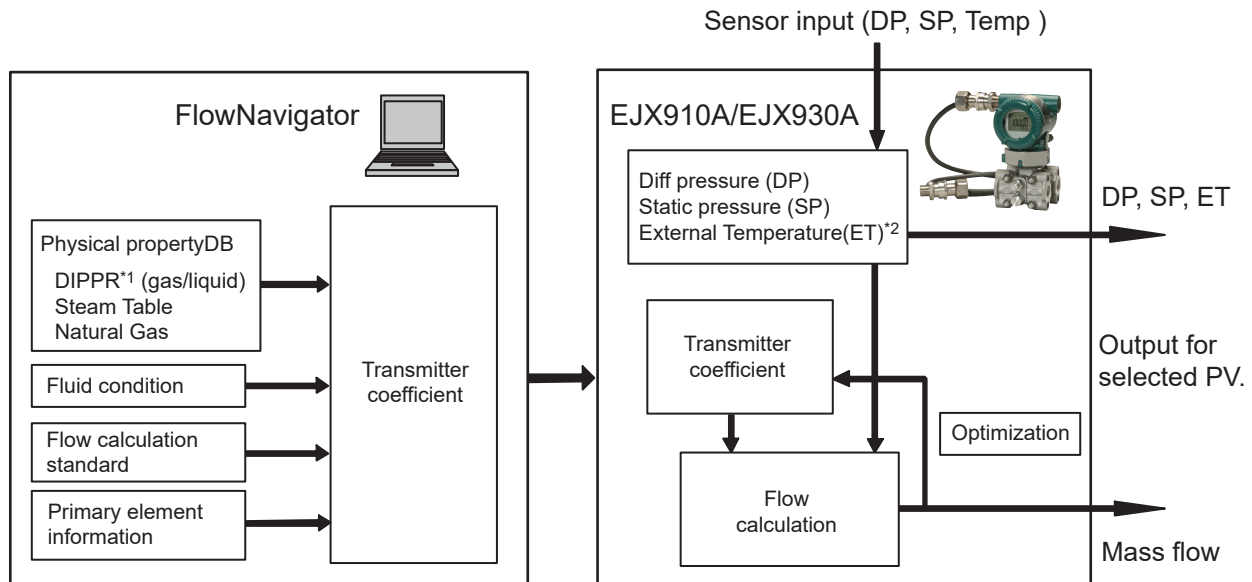

*1: AIChE, DIPPR (Design Institute for Physical Properties) is a registered trademark of American Institute of Chemical Engineers.

*2: External temperature is calculated from static pressure by using the built-in steam table when the saturated steam mode (ET Fixed = Saturated Steam) is set. This mode is only available in HART communication type device revision 12 or later.

F0203.ai

Figure 2.3 Auto Compensation Mode Block Diagram

2.4.1 Configuration Procedure for Auto Compensation Mode

The FlowNavigator is required to configure auto compensation mode. Following shows the procedures for HART communication type.

Before starting the configuration procedure, have on hand all data on the fluid and the primary devices.

- (1) Have ready a power supply, a personal computer, a HART modem, and the FSA120 Flow Configuration Software. (FlowNavigator)
- (2) Install the mass flow configuration software on the personal computer.
- (3) Connect the EJX multivariable transmitter to the power supply.



NOTE

Configuration can be done when the RTD is not connected, but alarm number 03 will be displayed on the indicator.

- (4) Connect the HART modem to the personal computer and connect its clips to the supply terminals on the transmitter.
- (5) Perform flow configuration.
- (6) Execute flow simulation using the HART HHT or the FlowNavigator to confirm the configured flow parameters.
When executing the simulation, it is necessary to connect the RTD or mock resistance (about 100Ω) to the transmitter.
Input the differential pressure, static pressure, and temperature values and confirm that the desired flow is obtained.
When the saturated steam mode (ET Fixed = Saturated Steam) is set, mass flow value is calculated from external temperature which is calculated by static pressure by using the built-in steam table instead of measuring or simulating external temperature. This mode is only available in device revision 12 or later.
User flow parameters (flow settings information input by FSA120 FlowNavigator) can be stored on the transmitter when the device revision is 12 or later.
- (7) Remove the HART modem from the transmitter.
- (8) Turn off the power supply.



NOTE

- (1) Refer to the following instruction manuals for more detailed explanation.
Setting with the HART HHT:
IM01C25R02-01E.
Setting with the Fieldbus configuration tool:
IM01C25R03-01E.
Setting with the FlowNavigator:
IM01C25R51-01E.
- (2) For the flow configuration in the field after installation, perform only steps 4 to 7.

2.5 Basic Mode (except Modbus Communication Type)

In the case of Basic mode, flow operation and density compensation are performed conventionally with the flow factors manually input.

The flow rate is calculated using the constant flow factor.

Density is compensated as follows according to the selection of gas or liquid.

Gas: Compensation as ideal gas by temperature and pressure.

Liquid: Compensation by temperature.

Select the operational expression according to the fluid type and unit category, as shown in Table 2.1.

Table 2.1 Flow Operational Expression for Basic Mode

Fluid type	Flow unit Category	Kfactor [In case of Orifice]	Flow
Liquid	Mass Flow	$Kfactor = \pi/4 \times Nc \times C / \sqrt{1-\beta^4} \times \epsilon \times d^2 \times \sqrt{2 \times \rho b}$	$Qm, Qv \text{ or } Qv_norm$ $= \underline{Kfactor} \times \sqrt{\Delta P \times (1 + \underline{Temp K1} \times (T - T_b))}$
	Normal · Standard Volume Flow	$Kfactor = \pi/4 \times Nc \times C / \sqrt{1-\beta^4} \times \epsilon \times d^2 \times \sqrt{2 \times \rho b} / \rho_{norm}$	
	Volume Flow	$Kfactor = \pi/4 \times Nc \times C / \sqrt{1-\beta^4} \times \epsilon \times d^2 \times \sqrt{2 / \rho b}$	
Gas	Mass Flow	$Kfactor = \pi/4 \times Nc \times C / \sqrt{1-\beta^4} \times \epsilon \times d^2 \times \sqrt{2 \times \rho b \times 1/K}$	$Qm \text{ or } Qv_norm$ $= \underline{Kfactor} \times \sqrt{\Delta P \times T_b / T \times SP / SPb}$
	Normal · Standard Volume Flow	$Kfactor = \pi/4 \times Nc \times C / \sqrt{1-\beta^4} \times \epsilon \times d^2 \times \sqrt{2 \times \rho b \times 1/K} / \rho_{norm}$	
	Volume Flow	$Kfactor = \pi/4 \times Nc \times C / \sqrt{1-\beta^4} \times \epsilon \times d^2 \times \sqrt{2 / (\rho b \times 1/K)}$	$Qv = \underline{Kfactor} \times \sqrt{\Delta P \times T / T_b \times SPb / SP}$

*1 == Custom setting Parameter

T0201.ai

Table 2.2 Symbols

#	Symbol	Description
1	Qm	Mass Flow
2	Qv	Volume Flow
3	Qv_norm	Normal·Standard Volume Flow
4	Nc	Unit convert factor
5	Kfactor	Basic flow Calculation factor
6	C	Discharge Coefficient
7	ε	Expansion Factor
8	β	Diameter Ratio
9	d	Diameter of orifice
10	Δp	Differential Pressure (Transmitter Setting unit)
11	ρb	Base Density on Tb, SPb Condition
12	ρnorm	Density on Normal, Standard condition
13	Tb	Reference temperature unit: K
14	T	Temperature unit: K
15	SPb	Reference static pressure unit: kPa abs
16	SP	Static Pressure unit: kPa abs
17	Temp K1	The density rate of change per temperature 1degC of a density base value (value which set 100% to 1) For volume flow: set 0.
18	K	Compressibility factor

Flow Unit Category

Table 2.3 Mass Flow Unit (HART communication type)

Unit	LCD	Communication
grams per second	g/s	←
grams per minute	g/m	g/min
grams per hour	g/h	←
kilograms per second	kg/s	←
kilograms per minute	kg/m	kg/min
kilograms per hour	kg/h	←
kilograms per day	kg/d	←
metric tons per minute	t/m	t/min
metric tons per hour	t/h	←
metric tons per day	t/d	←
pounds per second	lb/s	←
pounds per minute	lb/m	lb/min
pounds per hour	lb/h	←
pounds per day	lb/d	←
short tons per minute	STon/m	STon/min
short tons per hour	STon/h	←
short tons per day	STon/d	←
long tons per hour	LTon/h	←
long tons per day	LTon/d	←

Table 2.4 Normal-Standard Volume Flow Unit (HART communication type)

Unit	LCD	Communication
normal cubic meter per hour	Nm3/h	←
normal liter per hour	NL/h	←
standard cubic feet per minute	SCFM	←
standard liter per hour	SL/h	←
standard liter per minute	SL/m	SL/min
standard liter per second	SL/s	←
normal cubic meter per day	Nm3/d	←
standard cubic feet per day	SCFD	←
standard cubic feet per hour	SCFH	←
standard cubic feet per second	SCFS	←
standard cubic meter per day	Sm3/d	←
standard cubic meter per hour	Sm3/h	←
thousand standard cubic feet per day	MSCFD	←
million standard cubic feet per day	MMSCFD	←

Table 2.5 Volume Flow Unit (HART communication type)

Unit	LCD	Communication
cubic feet per minute	CFM	←
gallons per minute	GPM	←
liters per minute	L/m	L/min
imperial gallons per minute	IGal/m	Impgal/min
cubic meter per hour	M3/h	←
gallons per second	gal/s	←
million gallons per day	Mgal/d	←
liters per second	L/s	←
million liters per day	ML/d	←
cubic feet per second	CFS	←
cubic feet per day	ft3/d	←
cubic meters per second	M3/s	←
cubic meters per day	M3/d	←
imperial gallons per hour	IGal/h	Impgal/h
imperial gallons per day	IGal/d	Impgal/d
cubic feet per hour	CFH	←
cubic meters per minute	m3/m	m3/min
barrels per second	bbbl/s	←
barrels per minute	bbbl/m	bbbl/min
barrels per hour	bbbl/h	←
barrels per day	bbbl/d	←
gallons per hour	gal/h	←
imperial gallons per second	IGal/s	Impgal/s
liters per hour	L/h	←
gallons per day	gal/d	←

2.5.1 Configuration Procedure for Basic Mode

Either a communicator or the mass flow configuration software is required to carry out configuration in basic mode.

Calculation of the basic mode parameters is necessary to perform configuration. Following shows the procedures for HART communication type.

- (1) Have ready a power supply, a personal computer, a HART modem and the FSA120 EJX-MV Configuration DTM.
- (2) Install the flow configuration software on the personal computer.
This is not necessary if only the HART communicator is used for configuration.
- (3) Connect the EJX multivariable transmitter to the power supply.



NOTE

Even when the RTD is not connected and alarm number 03 is displayed on the indicator, setting can be performed.

- (4) Connect the HART communicator or the HART modem to the transmitter.
- (5) Perform flow configuration.
- (6) Execute flow simulation with the HART HHT or the FSA120 software in order to confirm the configured flow parameters.
When the simulation is carried out, it is necessary to connect the RTD or mock resistance (about 100Ω) to the transmitter. Input the differential pressure, static pressure, and temperature values and then confirm that the desired flow has been obtained.
When the saturated steam mode (ET Fixed = Saturated Steam) is set, mass flow value is calculated from external temperature which is calculated by static pressure by using the built-in steam table instead of measuring or simulating external temperature. This mode is only available in device revision 12 or later.
- (7) Remove the HART communicator or the HART modem from the transmitter.
- (8) Turn off the power supply.



NOTE

- (1) Refer to the following instruction manuals for more detailed explanation.
 Setting with the HART HHT:
 IM01C25R02-01E.
 Setting with the Fieldbus configuration tool:
 IM01C25R03-01E.
 Setting with the FSA120: IM01C51R01-01E.
- (2) For the flow configuration in the field after installation, perform only steps 4 to 7.

2.5.2 Calculation of the Basic mode parameters

There are two methods for the calculation of the Basic mode parameters.

Method 1: Calculating the Kfactor by flow parameters

Method 2: Calculating the Kfactor by means of the flow condition

Method 1. Calculating the Kfactor by flow parameters. [In case of Orifice]

- (1) Selection of the flow equation
 Select the desired operational expression according to the fluid type and the flow unit category shown in Table 2.1.
- (2) Confirming the unit
 The unit to be used in this calculation is as follows:
 Differential pressure: Pa
 Static Pressure: kPa abs
 Temperature: K
 The dimension of the pressure unit Pa are $M \cdot L^{-1} \cdot S^{-2}$
 Where M: mass (kg)
 L: Length (m)
 S: Time (s)
- (3) Preparation of flow parameters for Kfactor calculation
 Each parameter must be expressed in the following units.
 d: m,
 pb and pnorm: kg/m^3
 C, β , ϵ and K has no dimensions

- (4) Calculation of the unit conversion coefficient Nc
 The flow rate value does not change automatically when a flow unit parameter is set for the transmitter, and is always output as kg/s (mass flow), m^3/s (volume flow), Nm^3/s (Normal volume flow.)
 In order to obtain a value in your designated unit, it is necessary to set Nc.
 Nc is a conversion coefficient for the flow and DP unit that is designated to be used.
- (5) Selection of the Kfactor equation and calculation
 Select the Kfactor expression according to the fluid type and the unit category shown in Table 2.1.
 Calculate the Kfactor using the parameters and the expression.
- (6) Downloading flow parameter to a transmitter
 Input Kfactor, Tb, SPb and TempK 1 to the transmitter using either a Communication tool or FlowNavigator.
 Use the unit of “ $kg/m^3/degC$ ” for TempK1



IMPORTANT

If either the setting of flow unit or differential pressure unit is changed, Kfactor and Nc must be recalculated.

Example 1: Calculation of Nc

(1) When flow unit is changed.

$$Nc = (\text{kg/s}) / (\text{Mass Flow unit in use})$$

Table 2.6 Example of Calculated Nc by Flow Unit

Flow unit	Calculation of Nc	Nc
kg/s	(kg/s) / (kg/s) = (1kg/1s) / (1kg/1s)	1
kg/h	(kg/s) / (kg/h) = (1kg/1s) / (1kg/3600s)	3600
lb/s	(kg/s) / (lb/s) = (1kg/1s) / (0.4535924kg/1s)	2.204623
lb/h	(kg/s) / (lb/h) = (1kg/1s) / (0.4535924kg/3600s)	7936.648

(2) When differential pressure unit is changed.

$$Nc = \sqrt{(\text{Differential pressure unit}) / (\text{Pa})}$$

Table 2.7 Example of Calculated Nc by Differential Pressure Unit

Δp unit	Calculation of Nc	Nc
Pa	$\sqrt{(\text{Pa}) / (\text{Pa})} = \sqrt{(1\text{Pa}) / (1\text{Pa})}$	$\sqrt{1} = 1$
kPa	$\sqrt{\text{kPa}/\text{Pa}} = \sqrt{1000\text{Pa} / 1\text{Pa}}$	$\sqrt{1000} = 31.62278$
inH2O@68degF	$\sqrt{\text{inH2O}@68\text{degF} / \text{Pa}} = \sqrt{248.6406\text{Pa} / 1\text{Pa}}$	$\sqrt{248.6406} = 15.76834$

T0202.ai

(3) When both flow unit and differential pressure unit are changed.

$$Nc = (\text{kg/s}) / (\text{Mass Flow unit of use}) \times \sqrt{(\text{Differential pressure unit of use}) / (\text{Pa})}$$

Example 2: Calculation of Kfactor [In case of Orifice]

Qm unit = kg/s, Differential pressure unit = kPa

$$\begin{aligned} K\text{factor} &= \pi/4 \times Nc \times C / \sqrt{1 - \beta^4} \times \epsilon \times d^2 \times \sqrt{2 \times \rho b \times 1 / K} \\ &= 0.7853982 \times 31.62278 \times 0.6043 / \sqrt{1 - 0.1296} \times 0.984 \times 0.03162^2 \times \sqrt{2 \times 1.250380 \times 1 / 1} \\ &= 0.02502868 \\ &\approx 0.02503 \end{aligned}$$

Table 2.8 Flow Parameter of Example

Symbol	Value	Description
C	0.6043	Discharge coefficient Orifice Corner Taps [ISO5167-1 1991] ReD 1×10 ⁶
ε	0.984	Expansion factor β=0.6, Δρ=50,000 Pa, SP=1,000,000 Pa abs, κ=1.399502
β	0.6	Diameter ratio
d	0.03162 m	Bore of orifice
D	0.0527 m	Pipe diameter
ρb	1.250380 kg/m ³	Base Density on Tb, SPb Condition (NITROGEN 101,325 Pa abs 273.15 K)
Tb	273.15 K(0 degC)	Reference temperature unit: K
SPb	101.325 kPa abs	Reference static pressure unit: kPa abs
K	1	Compressibility factor
π/4	0.7853982	
Nc	31.62278	Unit convert factor when DP unit is kPa $\sqrt{\text{kPa}/\text{Pa}} = \sqrt{1000\text{Pa} / 1\text{Pa}} = 31.62278$

T0203.ai

Example 3: Calculation of Qm

$\Delta p = 50\text{kPa}$, $SP = 500\text{kPa abs}$, $T = 293.15\text{K}$

$$\begin{aligned} Q_m(\text{kg/s}) &= K_{\text{factor}} \times \sqrt{\Delta p \times (T_b / T) \times (SP / SP_b)} \\ &= 0.02503 \times \sqrt{50 \times (273.15 / 293.15) \times (500 / 101.325)} \\ &= 0.3795 \text{ (kg/s)} \end{aligned}$$

Method 2. Calculating the Kfactor by means of the flow condition.

Flow condition; DP, SP, SPb, T, Tb, and TempK1

- (1) Selection of the flow equation
Select a desired operational expression according to the fluid type and the flow unit category shown in Table 2.1.
- (2) Confirming the units
The unit to be used in the flow calculation is as follows.
Static Pressure : kPa abs
Temperature : K
Regardless of the actual setting of the unit for these items in the transmitter, the above units are used for calculation.
The flow and the differential pressure are calculated using the unit set to the transmitter.
- (3) Preparation of parameters for calculation
All parameters use the units which are shown at (2).
- (4) Calculation of the Kfactor
Calculate the Kfactor by using the parameters prepared at (3) and flow expression selected at (1).
- (5) Downloading flow parameter to transmitter.
Input Kfactor, Tb, SPb, and TempK1(liquid) to the transmitter by a communication tool or EJXMVTool.

**IMPORTANT**

If either the setting of flow unit or differential pressure unit is changed, Kfactor must be recalculated.

Example: Kfactor Calculation

Table 2.9 Flow Condition Example

Symbol	Value	Description
Qm	3011.76 (lb/h)	
Δp	201.0935 inH2O@68degF	Differential pressure
Tb	273.15 K	Reference temperature unit: K
SPb	101.325 kPa abs	Reference static pressure unit: kPa abs
T	293.15 K	Temperature unit: K
SP	500 kPa abs	Static pressure unit: kPa abs

$$\begin{aligned}
 \text{Kfactor} &= \text{Qm}(\text{lb/h}) / \sqrt{\Delta p \times (\text{Tb} / \text{T}) \times (\text{SP} / \text{SPb})} \\
 &= 3011.76 / \sqrt{201.0935 \times (273.15 / 293.15) \times (500 / 101.325)} \\
 &= 99.0464
 \end{aligned}$$

Table 2.10 For HART Communicator (Function : Basic Flow Calc)

Symbol	HART Parameter name	Item
Kfactor	Flow Calc Fixed	Calcuration fixation value of flow
SPb	Ref SP	Reference static pressure
Tb	Ref Temp	Reference pressure
TempK1	Temp K1	The first in temperature correction coefficient for liquid For volume flow: set 0.

3. Handling Cautions

This chapter provides important information on how to handle the transmitter. Read this carefully before using the transmitter.

EJX Series transmitters are thoroughly tested at the factory before shipment. When taking delivery of an instrument, visually check them to make sure that no damage occurred during shipment.

Also check that all transmitter mounting hardware shown in figure 3.1 is included. If the transmitter is ordered without the mounting bracket and the process connector, the transmitter mounting hardware will not be included. When the option code /BS is specified, a process connector for Low pressure side will not be attached. After checking the transmitter, carefully repack it in its box and keep it there until you are ready to install it.

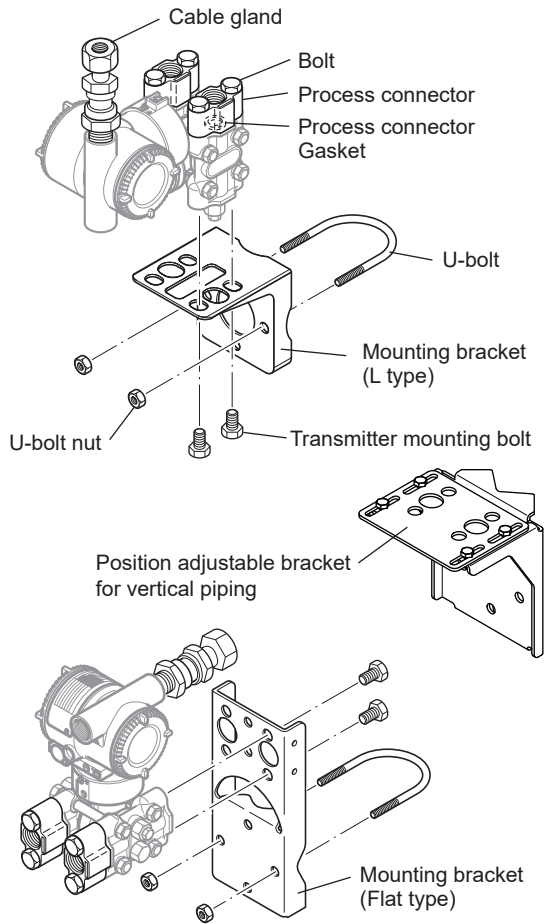

F0301.ai

Figure 3.1 Transmitter Mounting Hardware

3.1 Model and Specifications Check

The model name and specifications are written on the name plate attached to the case.

- Except Modbus Communication Type

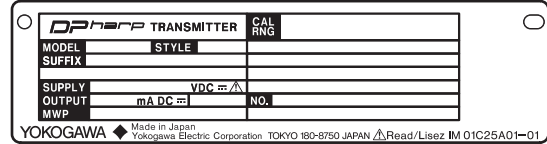

- Modbus Communication Type

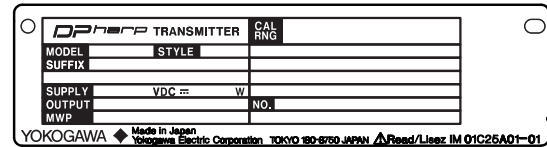

- For FOUNDATION Fieldbus communication type, refer to IM 01C25R03-01E.

F0302.ai

Figure 3.2 Name Plate

3.2 Unpacking

Keep the transmitter in its original packaging to prevent it from being damaged during shipment. Do not unpack the transmitter until it reaches the installation site.

3.3 Storage

The following precautions must be observed when storing the instrument, especially for a long period.

- (a) Select a storage area which meets the following conditions:
- It is not exposed to rain or subject to water seepage/leaks.
 - Vibration and shock are kept to a minimum.
 - It has an ambient temperature and relative humidity within the following ranges.

Ambient temperature:

–40* to 85°C without integral indicator

–30* to 80°C with integral indicator

* –15°C when /HE is specified.

Relative humidity:

0% to 100% R.H.

Preferred temperature and humidity:

approx. 25°C and 65% R.H.

- (b) When storing the transmitter, repack it carefully in the packaging that it was originally shipped with.
- (c) If the transmitter has been used, thoroughly clean the chambers inside the cover flanges, so that there is no process fluid remaining inside. Before placing it in storage, also make sure that the pressure-detector is securely connected to the transmitter section.

3.4 Selecting the Installation Location

The transmitter is designed to withstand severe environmental conditions. However, to ensure that it will provide years of stable and accurate performance, take the following precautions when selecting the installation location.

- (a) Ambient Temperature
Avoid locations subject to wide temperature variations or a significant temperature gradient. If the location is exposed to direct sunlight or radiant heat from plant equipment, provide adequate shade, thermal insulation and/or ventilation.
- (b) Ambient Atmosphere
Do not install the transmitter in a corrosive atmosphere. If this cannot be avoided, there must be adequate ventilation as well as measures to prevent the leaking of rain water and the presence of standing water in the conduits.

- (c) Shock and Vibration
Although the transmitter is designed to be relatively resistant to shock and vibration, an installation site should be selected where this is kept to a minimum.
- (d) Installation of Explosion-protected Transmitters
An explosion-protected transmitters is certified for installation in a hazardous area containing specific gas types. See subsection 3.9 "Installation of an Explosion-Protected Transmitters."

3.5 Pressure Connection



WARNING

- Never loosen the process connector bolts when an instrument is installed in a process. The device is under pressure, and a loss of seal can result in a sudden and uncontrolled release of process fluid.
- When draining toxic process fluids that have condensed inside the pressure detector, take appropriate steps to prevent the contact of such fluids with the skin or eyes and the inhalation of vapors from these fluids.

The following precautions must be observed in order to safely operate the transmitter under pressure.

- (a) Make sure that all the process connector bolts are tightened firmly.
- (b) Make sure that there are no leaks in the impulse piping.
- (c) Never apply a pressure higher than the specified maximum working pressure.

3.6 Waterproofing of Cable Conduit Connections

Apply a non-hardening sealant to the threads to waterproof the transmitter cable conduit connections. (See figure 7.8, 7.9 and 7.10)

3.7 Restrictions on Use of Radio Transceivers



IMPORTANT

Although the transmitter has been designed to resist high frequency electrical noise, if a radio transceiver is used near the transmitter or its external wiring, the transmitter may be affected by high frequency noise pickup. To test this, start out from a distance of several meters and slowly approach the transmitter with the transceiver while observing the measurement loop for noise effects. Thereafter use the transceiver outside the range where the noise effects were first observed.

3.8 Insulation Resistance and Dielectric Strength Test

Since the transmitter has undergone insulation resistance and dielectric strength tests at the factory before shipment, normally these tests are not required. If the need arises to conduct these tests, heed the following:

- (a) Do not perform such tests more frequently than is absolutely necessary. Even test voltages that do not cause visible damage to the insulation may degrade the insulation and reduce safety margins.
- (b) Never apply a voltage exceeding 500 V DC (100 V DC with an internal lightning protector) for the insulation resistance test, nor a voltage exceeding 500 V AC (100 V AC with an internal lightning protector) for the dielectric strength test.
- (c) Before conducting these tests, disconnect all signal lines from the transmitter terminals. The procedure for conducting these tests is as follows:

• Insulation Resistance Test

- 1) Short-circuit the following terminals:
For Modbus, four terminals of "SUPPLY +, SUPPLY -, A, and B" in the terminal box. For except Modbus, three terminals of "SUPPLY +, SUPPLY -, and PULSE +" in the terminal box.
- 2) Turn OFF the insulation tester. Then connect the insulation tester plus (+) lead wire to the shorted SUPPLY terminals and the minus (-) leadwire to the grounding terminal.

- 3) Turn ON the insulation tester power and measure the insulation resistance. The voltage should be applied as briefly as possible to verify that the insulation resistance is at least 20 MΩ.
- 4) After completing the test and being very careful not to touch exposed conductors disconnect the insulation tester and connect a 100 kΩ resistor between the grounding terminal and the short-circuiting SUPPLY terminals. Leave this resistor connected at least one second to discharge any static potential. Do not touch the terminals while it is discharging.

• Dielectric Strength Test

- 1) Short-circuit the following terminals:
For Modbus, four terminals of "SUPPLY +, SUPPLY -, A, and B" in the terminal box. For except Modbus, three terminals of "SUPPLY +, SUPPLY -, and PULSE +" in the terminal box.
- 2) Turn OFF the dielectric strength tester. Then connect the tester between the shorted SUPPLY terminals and the grounding terminal. Be sure to connect the grounding lead of the dielectric strength tester to the ground terminal.
- 3) Set the current limit on the dielectric strength tester to 10 mA, then turn ON the power and gradually increase the test voltage from '0' to the specified voltage.
- 4) When the specified voltage is reached, hold it for one minute.
- 5) After completing this test, slowly decrease the voltage to avoid any voltage surges.

3.9 Installation of an Explosion-Protected Instrument



WARNING

For FOUNDATION Fieldbus explosion protected type, please refer to IM 01C25R03-01E.

If a customer makes a repair or modification to an intrinsically safe or explosionproof instrument and the instrument is not restored to its original condition, its intrinsically safe or explosionproof construction may be compromised and the instrument may be hazardous to operate. Please contact Yokogawa before making any repair or modification to an instrument.



CAUTION

This instrument has been tested and certified as being intrinsically safe or explosionproof. Please note that severe restrictions apply to this instrument's construction, installation, external wiring, maintenance and repair. A failure to abide by these restrictions could make the instrument a hazard to operate.



WARNING

Maintaining the safety of explosionproof equipment requires great care during mounting, wiring, and piping. Safety requirements also place restrictions on maintenance and repair. Please read the following sections very carefully.



WARNING

The range setting switch must not be used in a hazardous area.



WARNING

Make sure to apply necessary protections on the external temperature input cable, so as to avoid damages leading to an earth fault.



IMPORTANT

All the blind plugs which accompany the EJX transmitters upon shipment from the factory are certified by the applicable agency in combination with the EJX series transmitters. The plugs which are marked with the symbols "◇ Ex" on their surfaces are certified only in combination with the EJX series transmitters.

3.9.1 FM Approval

a. FM Explosionproof Type

Caution for FM explosionproof type.

Note 1. EJX multivariable transmitter with optional code /FF1 are applicable for use in hazardous locations.

- Applicable Standard: FM3600, FM3615, FM3810, NEMA 250, ANSI/UL 61010-1, ANSI/UL 61010-2-30
- Explosionproof for Class I, Division 1, Groups B, C and D.
- Dust-ignitionproof for Class II/III, Division 1, Groups E, F and G.
- Enclosure: Type 4X
- Temperature Class: T6
- Ambient Temperature: -40 to 60°C
- Supply Voltage: 42 V dc max.
32 V dc max. (FOUNDATION Fieldbus type)
9 to 30 V dc, 250 mW (RS485 Modbus Communication Type)
- Output signal: 4 to 20 mA
15 mA (FOUNDATION Fieldbus type)
RS485 Modbus (RS485 Modbus Communication Type)

Note 2. Wiring

- All wiring shall comply with National Electrical Code ANSI/NFPA70 and Local Electrical Codes.
- When installed in Division 1, "FACTORY SEALED, CONDUIT SEAL NOT REQUIRED."

Note 3. Operation

- Keep the "WARNING" nameplate attached to the transmitter.
WARNING: OPEN CIRCUIT BEFORE REMOVING COVER. FACTORY SEALED, CONDUIT SEAL NOT REQUIRED. INSTALL IN ACCORDANCE WITH THE USERS MANUAL IM 01C25.
- Take care not to generate mechanical sparking when accessing to the instrument and peripheral devices in a hazardous location.

Note 4. Maintenance and Repair

- The instrument modification or parts replacement by other than authorized representative of Yokogawa Electric Corporation is prohibited and will void Factory Mutual Explosionproof Approval.

3.9.2 CSA Certification

a. CSA Explosionproof Type

Caution for CSA explosionproof type.

Note 1. EJX multivariable transmitter with optional code /CF1 are applicable for use in hazardous locations:

- Certificate: 2014354
 - Applicable Standard: C22.2 No.0, C22.2 No.0.4, C22.2 No.0.5, C22.2 No.25, C22.2 No.30, C22.2 No.94, C22.2 No.61010-1, C22.2 No.60079-0, C22.2 No.61010-2-030, C22.2 No.60079-1
- [For CSA C22.2]
- Explosion-proof for Class I, Groups B, C and D.
 - Dustignition-proof for Class II/III, Groups E, F and G.
 - Enclosure: Type 4X
 - Temperature Code: T6...T4
- [For CSA E60079]
- Flameproof for Zone 1, Ex d IIC T6...T4
 - Enclosure: IP66 and IP67
 - Maximum Process Temperature: 120°C (T4), 100°C (T5), 85°C (T6)
 - Ambient Temperature: -50* to 75°C (T4), -50* to 80°C (T5), -50* to 75°C (T6)
* -15°C when /HE is specified.

- Power Supply: 42 V dc max. (HART Communication Type)
9 to 30 V dc, 250 mW (RS485 Modbus Communication Type)
32 V dc max. (FOUNDATION Fieldbus type)
- Output signal: 4 to 20 mA (HART Communication Type)
RS485 Modbus (RS485 Modbus Communication Type)
15 mA (FOUNDATION Fieldbus type)

Note 2. Wiring

- All wiring shall comply with Canadian Electrical Code Part I and Local Electrical Codes.
- In hazardous location, wiring shall be in conduit as shown in the figure.
- WARNING: A SEAL SHALL BE INSTALLED WITHIN 50cm OF THE ENCLOSURE.
UN SCELLEMENT DOIT ÊTRE INSTALLÉ À MOINS DE 50cm DU BOÎTIER.

- WARNING: WHEN INSTALLED IN CL.I, DIV 2, SEAL NOT REQUIRED.
UNE FOIS INSTALLÉ DANS CL I, DIV 2, AUCUN JOINT N'EST REQUIS.

Note 3. Operation

- WARNING: AFTER DE-ENERGIZING, DELAY 5 MINUTES BEFORE OPENING.
APRÈS POWER-OFF, ATTENDRE 5 MINUTES AVANT D'OUVRIER.
- WARNING: WHEN AMBIENT TEMPERATURE $\geq 65^{\circ}\text{C}$, USE THE HEAT-RESISTING CABLES $\geq 90^{\circ}\text{C}$.
QUAND LA TEMPÉRATURE AMBIANTE $\geq 65^{\circ}\text{C}$, UTILISEZ DES CÂBLES RÉSISTANTES À LA CHALEUR $\geq 90^{\circ}\text{C}$.
- Take care not to generate mechanical sparking when accessing to the instrument and peripheral devices in a hazardous location.

Note 4. Maintenance and Repair

- The instrument modification or parts replacement by other than authorized representative of Yokogawa Electric Corporation and Yokogawa Corporation of America is prohibited and will void Canadian Standards Explosionproof Certification.

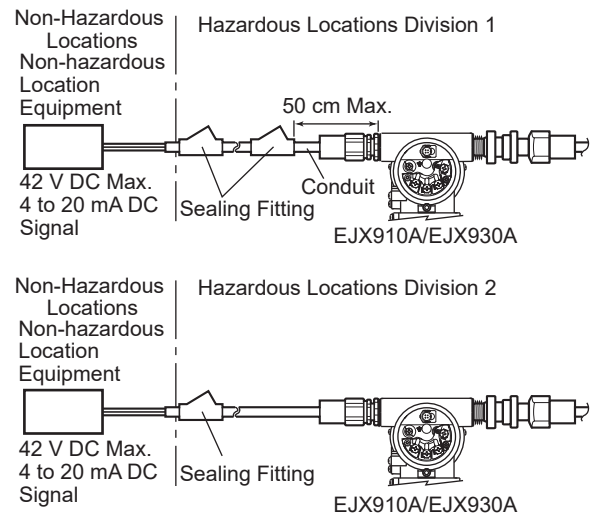

F0304.ai

3.9.3 ATEX Certification

ATEX Certification

(1) Technical Data

a. ATEX Flameproof Type

Caution for ATEX flameproof type.

- Note 1. EJX Series pressure transmitters with optional code /KF22 for potentially explosive atmospheres:
- No. KEMA 07ATEX0109 X
 - Applicable Standard: EN IEC 60079-0, EN 60079-1, EN 60079-31
 - Type of Protection and Marking Code: Ex db IIC T6...T4 Gb, Ex tb IIIC T85°C Db
 - Group: II
 - Category: 2G, 2D
 - Enclosure: IP66 / IP67
 - Temperature Class for gas-proof: T6, T5, and T4
 - Ambient Temperature for gas-proof: -50 to 75°C (T6), -50 to 80°C (T5), and -50 to 75°C (T4)
 - Process Temperature (Tp.) for gas-proof: -50 to 85°C (T6), -50 to 100°C (T5), and -50 to 120°C (T4)
 - Maximum Surface Temperature for dust-proof: T85°C (Tamb.: -30* to 75°C, Tp.: -30* to 85°C)
* -15°C when /HE is specified.

Note 2. Electrical Data

- Power Supply: 42 V dc max. (HART Communication Type)
9 to 30 V dc, 250 mW (RS485 Modbus Communication Type)
- Output signal: 4 to 20 mA (HART Communication Type)
RS485 Modbus (RS485 Modbus Communication Type)
32 V dc max. (FOUNDATION Fieldbus type)

Note 3. For combined approval types

- Once a device of multiple approval type is installed, it should not be re-installed using any other approval types. Apply a permanent mark in the check box of the selected approval type on the certification label on the transmitter to distinguish it from unused approval types.

Note 4. Installation

- All wiring shall comply with local installation requirement.
- Cable glands, adapters and/or blanking elements with a suitable IP rating shall be of Ex d IIC/Ex tb IIIC certified by ATEX and shall be installed so as to maintain the specific degree of protection (IP Code) of the equipment.
- In order to prevent the earthing conductor from loosening, the conductor must be secured to the terminal, tightening the screw with appropriate torque. Care must be taken not to twist the conductor.

Note 5. Operation

- WARNING: AFTER DE-ENERGIZING, DELAY 5 MINUTES BEFORE OPENING. WHEN THE AMBIENT TEMP. ≥ 65°C, USE HEAT-RESISTING CABLE AND CABLE GLAND ≥ 90°C.
- Take care not to generate mechanical sparking when accessing to the instrument and peripheral devices in a hazardous location.

Note 6. Maintenance and Repair

- Warning: When maintenance and repair are performed, confirm the following conditions and then perform works. Confirm the power supply is cut off and the voltage of power supply terminal is not supplied.
- Only personnel authorized by Yokogawa Electric Corporation can repair the equipment in accordance with the relevant standards: IEC / EN 60079-19 (Equipment repair, overhaul and reclamation) and IEC / EN 60079-17 (Electrical installation inspection and maintenance); otherwise the certification will be voided.

Note 7. Special Conditions for Safe Use

WARNING

- Electrostatic charge may cause an explosion hazard. Avoid any actions that cause the generation of electrostatic charge, such as rubbing with a dry cloth on coating face of the product.
- In the case where the enclosure of the Pressure Transmitter is made of aluminium, if it is mounted in an area where the use of category 2D apparatus is required, it shall be installed in such a way that the risk from electrostatic discharges and propagating brush discharges caused by rapid flow of dust is avoided.
- The fasteners used to fasten the transmitter enclosure onto the sensor capsule is special fastener, and the property class of it is A2-50 (A4-50) or more.
- For transmitters with a membrane made of titanium, ignition hazard due to impact and friction on the membranes shall be avoided.
- Maximum Surface Temperature for dust-proof: T85°C (Tamb.: -30* to 75°C, Tp.: -30* to 85°C)
* -15°C when /HE is specified.

(2) Electrical Connection

A mark indicating the electrical connection type is stamped near the electrical connection port.

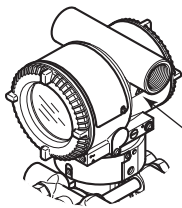

Location of the mark

F0307.ai

(3) Name Plate

- Name plate
- HART Communication Type

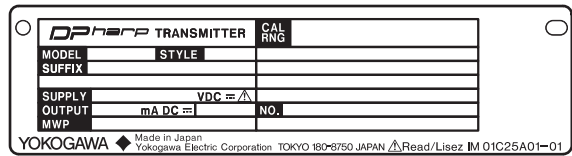

- Modbus Communication Type

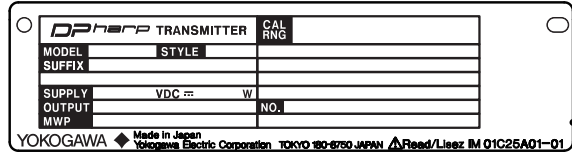

- For FOUNDATION Fieldbus communication type, refer to IM 01C25R03-01E.

- Tag plate for flameproof type

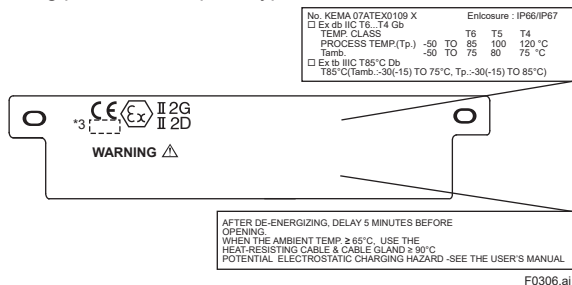

MODEL: Specified model code.
 STYLE: Style code
 SUFFIX: Specified suffix code.
 SUPPLY: Supply voltage (HART Communication Type)
 Supply voltage and Power (Modbus Communication Type)
 For FOUNDATION Fieldbus communication type, refer to IM 01C25R03-01E.

OUTPUT: Output signal.
 MWP: Maximum working pressure.
 CAL RNG: Specified calibration range.
 NO.: Serial number and year of production*1.
 TOKYO 180-8750 JAPAN:
 The manufacturer name and the address*2.

*1: The first number in the second block of "NO." column is the last one number of the production year.

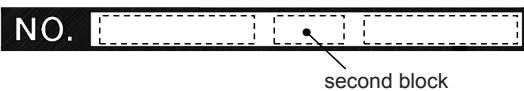

NO. 91K819857 132 7
 ↑
 The year 2011

*2: "180-8750" is a zip code which represents the following address.
 2-9-32 Nakacho, Musashino-shi, Tokyo Japan

*3: The identification number of Notified Body.

3.9.4 IECEx Certification

a. IECEx Flameproof Type (/SF2)

Caution for IECEx flameproof type.

Note 1. EJX multivariable transmitter with optional code /SF2 are applicable for use in hazardous locations:

- No. IECEx CSA 07.0008
- Applicable Standard: IEC60079-0:2011, IEC60079-1:2007-4
- Flameproof for Zone 1, Ex d IIC T6...T4 Gb
- Enclosure: IP66 and IP67
- Maximum Process Temperature: 120°C (T4), 100°C (T5), 85°C (T6)
- Ambient Temperature: -50 to 75°C (T4), -50 to 80°C (T5), -50 to 75°C (T6)
- Power Supply: 42 V dc max. (HART Communication Type) 9 to 30 V dc, 250 mW (RS485 Modbus Communication Type) 32 V dc max. (FOUNDATION Fieldbus type)
- Output signal: 4 to 20 mA (HART Communication Type) RS485 Modbus (RS485 Modbus Communication Type) 15 mA (FOUNDATION Fieldbus type)

Note 2. Wiring

- In hazardous locations, the cable entry devices shall be of a certified flameproof type, suitable for the conditions of use and correctly installed.
- Unused apertures shall be closed with suitable flameproof certified blanking elements.

Note 3. Operation

- WARNING: AFTER DE-ENERGIZING, DELAY 5 MINUTES BEFORE OPENING.
- WHEN THE AMBIENT TEMP. ≥ 65°C, USE HEAT-RESISTING CABLE AND CABLE GLAND ≥ 90°C.
- Take care not to generate mechanical sparking when accessing to the instrument and peripheral devices in a hazardous location.
- Electrostatic charge may cause an explosion hazard. Avoid any actions that cause the generation of electrostatic charge, such as rubbing with a dry cloth on coating face of the product.

Note 4. Maintenance and Repair

- The instrument modification or parts replacement by other than authorized representative of Yokogawa Electric Corporation is prohibited and will void IECEx Certification.
- Electrical Connection
A mark indicating the electrical connection type is stamped near the electrical connection port. These marks are as followed.

Screw Size	Marking
ISO M20 × 1.5 female	△ M
ANSI 1/2 NPT female	△ N or △ W

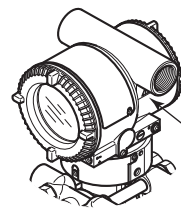

Location of the mark

F0308.ai

b. IECEx Flameproof type (/SF22)

Caution for IECEx flameproof type.

Note 1. EJX/EJA-E Series pressure transmitters with optional code /SF22 are applicable for use in hazardous locations:

- No. IECEx DEK 14.0046X
- Applicable Standard: IEC60079-0, IEC60079-1, IEC 60079-31
- Type of Protection and Marking Code: Ex db IIC T6...T4 Gb Ex tb IIIC T85°C Db
- Enclosure: IP66/IP67
- Temperature Class for gas-proof: T6, T5, and T4
- Ambient Temperature for gas-proof: -50 to 75°C (T6), -50 to 80°C (T5), and -50 to 75°C (T4)
- Process Temperature (Tp.) for gas-proof: -50 to 85°C (T6), -50 to 100°C (T5), and -50 to 120°C (T4)
- Maximum Surface Temperature for dust-proof: T85°C (Tamb.: -30* to 75°C, Tp.: -30* to 85°C)
* -15°C when /HE is specified.

Note 2. Electrical Data

- Supply voltage: 42 V dc max. 32 V dc max. (FOUNDATION Fieldbus type) 9 to 30 V dc, 250 mW (RS485 Modbus Communication Type)

- Output signal: 4 to 20 mA, 15 mA (FOUNDATION Fieldbus type) RS485 Modbus (RS485 Modbus Communication Type)

Note 3. For combined approval types Once a device of multiple approval type is installed, it should not be re-installed using any other approval types. Apply a permanent mark in the check box of the selected approval type on the certification label on the transmitter to distinguish it from unused approval types.

Note 4. Installation

- All wiring shall comply with local installation requirement.
- In order to prevent the earthing conductor from loosening, the conductor must be secured to the terminal, tightening the screw with appropriate torque. Care must be taken not to twist the conductor.
- Cable glands, adapters and/or blanking elements with a suitable IP rating shall be of Ex d IIC/Ex tb IIIC certified by IECEx and shall be installed so as to maintain the specific degree of protection (IP Code) of the equipment.
- Electrical Connection
A mark indicating the electrical connection type is stamped near the electrical connection port. These marks are as followed.

Screw Size	Marking
ISO M20 × 1.5 female	△ M
ANSI 1/2 NPT female	△ N or △ W

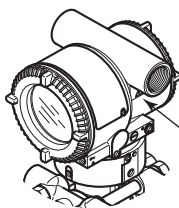

Location of the mark

F0308.ai

Note 5. Operation

- Keep the “WARNING” label at the transmitter.
- WARNING:
- AFTER DE-ENERGIZING, DELAY 5 MINUTES BEFORE OPENING. WHEN THE AMBIENT TEMP. ≥ 65°C, USE HEAT-RESISTING CABLE AND CABLE GLAND ≥ 90°C.

- Take care not to generate mechanical sparking when accessing to the instrument and peripheral devices in a hazardous location.

Note 6. Maintenance and Repair

- WARNING:
- When maintenance and repair are performed, confirm the following conditions and then perform works Confirm the power supply is cut off and the voltage of power supply terminal is not supplied.
- Only personnel authorized by Yokogawa Electric Corporation can repair the equipment in accordance with the relevant standards: IEC 60079-19 (Equipment repair, overhaul and reclamation) and IEC 60079-17 (Electrical installation inspection and maintenance); otherwise the certification will be voided.

Note 7. Specific Conditions of Use

- WARNING:
- Electrostatic charge may cause an explosion hazard. Avoid any actions that cause the generation of electrostatic charge, such as rubbing with a dry cloth on coating face of the product.
- The flame paths differ from the standard values in IEC 60079-1. Repair of the equipment is only allowed when done by the manufacturer or an authorized representative.
- The fasteners used to fasten the transmitter enclosure onto the sensor capsule is special fastener, and the property class of it is A2-50(A4-50) or more.
- For transmitters with a membrane made of titanium, ignition hazard due to impact and friction on the membranes shall be avoided.
- Maximum Surface Temperature for dust-proof: T85°C (Tamb.: -30* to 75°C, Tp.: -30* to 85°C)
* -15°C when /HE is specified.

3.10 EMC Conformity Standards

EN 61326-1 Class A, Table 2

EN 61326-2-3

EN 61326-2-5 (for Fieldbus)

Immunity influence during the test

Differential pressure: Output shift is specified within $\pm 1\%$ of 1/10 Max span.

Static pressure: Output shift is specified within $\pm 2\%$ of 1 MPa span.

External temperature: Output shift is specified within $\pm 5^\circ\text{C}$.

Status Output Line*: Continues to operate without reversal.

*: in case of output signal code E and J.

Mass flow rate: Output shift is specified within $\pm 3\%$ of 1/10 flow range.

Condition for EMC test for FOUNDATION Fieldbus type: The shield of the cable and the case are connected with a capacitor of 10 nF.



CAUTION

- This instrument is a Class A product, and it is designed for use in the industrial environment. Please use this instrument in the industrial environment only.
- To meet EMC regulations, Yokogawa recommends that customers run signal wiring through metal conduits or use shielded twisted-pair cabling when installing EJX series transmitters in a plant.

3.11 Pressure Equipment Directive (PED)

(1) General

- EJX series pressure transmitters are categorized as piping under the pressure accessories section of directive 2014/68/EU, which corresponds to Article 4, Paragraph 3 of PED, denoted as Sound Engineering Practice (SEP).
- EJX910A-□M, EJX910A-□H, EJX930A-□M, and EJX930A-□H can be used above 200 bar and therefore considered as a part of a pressure retaining vessel where category III, Module H applies. These models with option code /PE3 conform to that category.

(2) Technical Data

- Models without /PE3
Article 4, Paragraph 3 of PED, denoted as Sound Engineering Practice (SEP).
- Models with /PE3
Module: H
Type of Equipmen: Pressure Accessory-Vessel
Type of fluid: Liquid and Gas
Group of fluid: 1 and 2

Model	Capsule code	PS*1 (bar)	V(L)	PS.V (bar.L)	Category*2
EJX910A	L	160	0.01	1.6	Article 4, Paragraph 3 (SEP)
	M, H	250	0.01	2.5	
EJX910A with code /PE3	M, H	250	0.01	2.5	III
EJX930A	M, H	500	0.01	5.0	Article 4, Paragraph 3 (SEP)
EJX930A with code /PE3	M, H	500	0.01	5.0	III

*1: PS is maximum pressure for vessel itself based on Pressure Equipment Directive 2014/68/EU. Refer to General specification for maximum working pressure of a transmitter.

*2: Referred to Table 1 covered by ANNEX II of EC Directive on Pressure Equipment Directive 2014/68/EU

(3) Operation**CAUTION**

- The temperature and pressure of fluid should be maintained at levels that are consistent with normal operating conditions.
- The ambient temperature should be maintained at a level that is consistent with normal operating conditions.
- Please take care to prevent water hammer and the like from inducing excessive pressures in pipes and valves. If phenomena are likely, install a safety valve or take some other appropriate measure to prevent pressure from exceeding PS.
- Take appropriate measures at the device or system level to protect transmitters if they are to be operated near an external heat source.

3.12 Safety Requirement Standards

Applicable standard: EN 61010-1, EN 61010-2-30, C22.2 No.61010-1, C22.2 No.61010-2-030

(1) Pollution Degree 2

“Pollution degree” describes the degree to which a solid, liquid, or gas which deteriorates dielectric strength or surface resistivity is adhering. “2” applies to normal indoor atmosphere. Normally, only non-conductive pollution occurs. Occasionally, however, temporary conductivity caused by condensation must be expected.

(2) Installation Category I

“Overvoltage category (Installation category)” describes a number which defines a transient overvoltage condition. It implies the regulation for impulse withstand voltage. “ I ” applies to electrical equipment which is supplied from the circuit when appropriate transient overvoltage control means (interfaces) are provided.

(3) Indoor/Outdoor use**3.13 EU-RoHS Directive**

Applicable standard: EN IEC 63000

Applicable production sites are shown below. The condition of the RoHS compliant production sites are as follows:

Japan, Germany, Saudi Arabia, India, USA

The production sites can be confirmed by the serial number shown in the frame of “NO.” in the name plate of the product.

Serial numbers (9 letters): **AA**nnnnnnnn

AA: Identification code of production site

Japan: Use “91” or “90”

USA: Use “U1”

Germany: Use “D1”

Saudi Arabia: Use “Y3”

India: Use “Y1”

4. Component Names

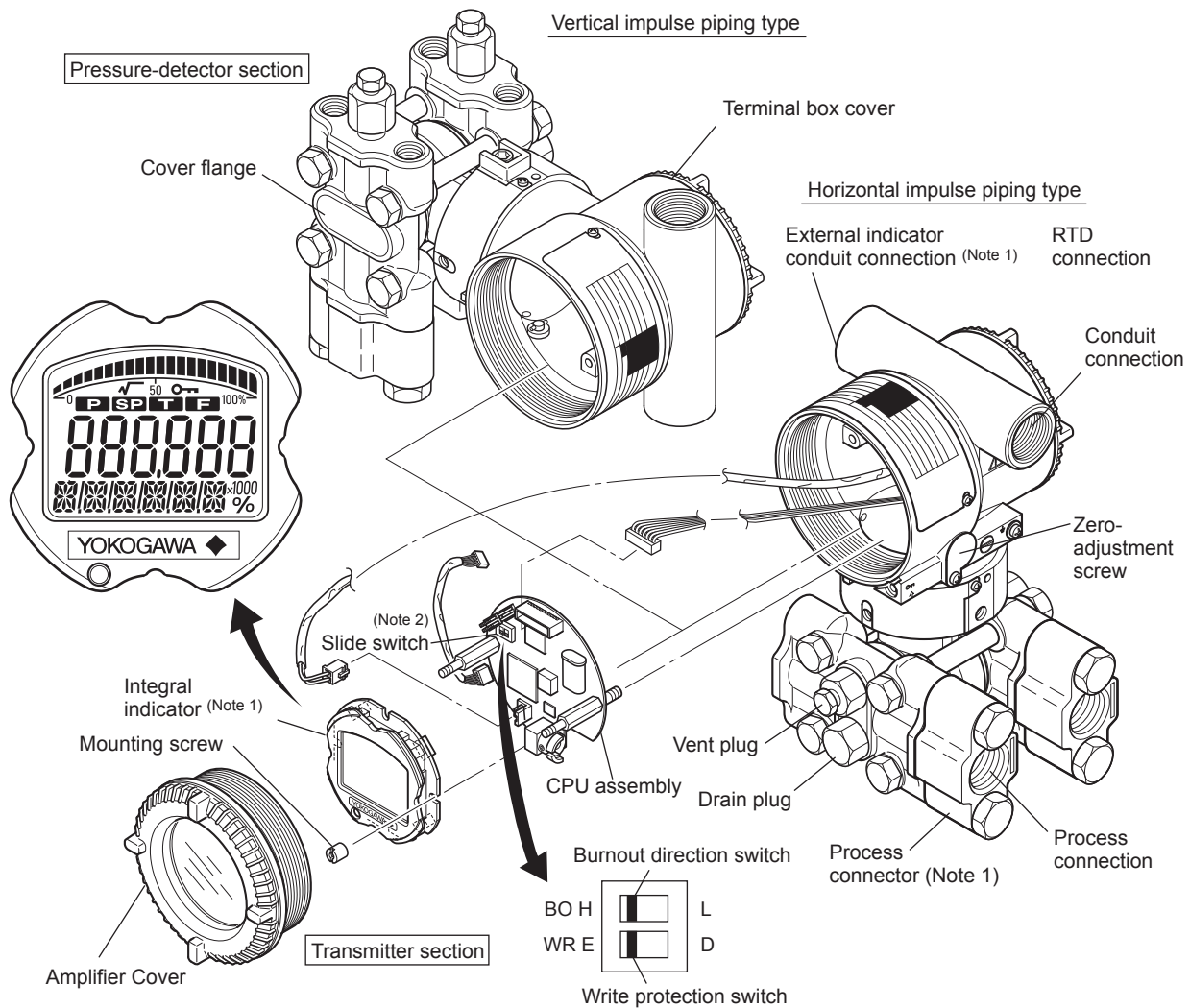

Burnout direction switch (BO)			Hardware write protection switch (WR)		
Burnout Direction Switch Position	H E	L D	H E	L D	H E
Burnout Direction	HIGH		LOW		Write Protection
			NO (Write enabled)	YES (Write disabled)	

F0401.ai

Note 1: See General Specifications sheet of each product for details. When the option code /BS is specified, a process connector for Low pressure side will not be attached.

Note 2: Applicable for HART communication type. Set the switches as shown in the figure above to set the burn-out direction and write protection. The Burnout switch is set to the H side for delivery (unless option code /C1 or /C2 is specified in the order), and the hardware write protection switch is set to E side. The setting of the switches can be confirmed via communication. An external zero adjustment screw can only be enabled by communication. To enabled the screw, set a parameter before activating the hardware write protect function. See each communication manual.

Note 3: An external zero point adjustment had been disabled by factory setting.

Figure 4.1 Component Names (Eg. HART Communication Type)

Table 4.1 Display Symbol

Display Symbol	Meaning of Display Symbol
▲	The output signal being zero-adjusted is increasing.
▼	The output signal being zero-adjusted is decreasing.
◻	Write protect function is enabled.

T0401.ai

5. Installation

5.1 Precautions

Before installing the transmitter, read the cautionary notes in section 3.4, "Selecting the Installation Location." For additional informations and limitations according to the selected model, suffix and option codes, please find information in each General Specifications sheet.



IMPORTANT

- When welding piping during construction, take care not to allow welding currents to flow through the transmitter.
- Do not step on this instrument after installation.

5.2 Mounting

- The transmitter is shipped with the process connection, according to the ordering specifications. To change the orientation of the process connections, refer to section 5.3.
- With differential pressure transmitters, the distance between the impulse piping connection ports is usually 54 mm (figure 5.1). By changing the orientation of the process connector, the dimension can be changed to 51 mm or 57 mm.
- The transmitter can be mounted on a nominal 2-inch pipe using the mounting bracket supplied, as shown in figure 5.2 and 5.3. The transmitter can be mounted on either a horizontal or a vertical pipe.
- When mounting the bracket on the transmitter, tighten the (four) bolts that hold the transmitter with a torque of approximately 39 N·m {4kgf·m}.

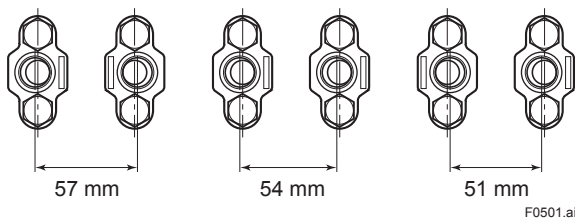
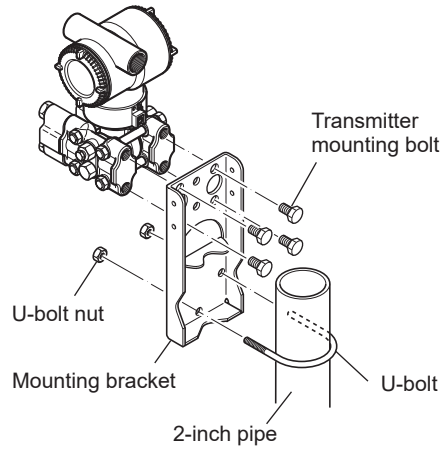
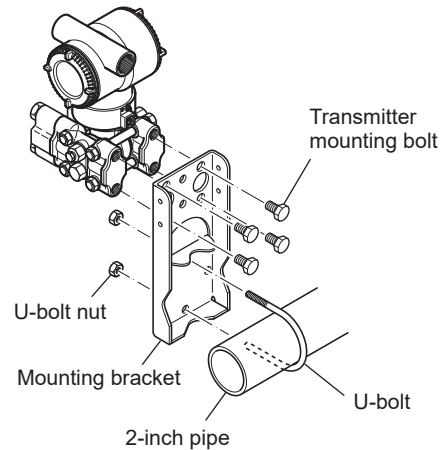

Figure 5.1 Process Connector Impulse Piping Connection Distances for multivariable Transmitters

Vertical pipe mounting



Horizontal pipe mounting



F0502.ai

Figure 5.2 Transmitter Mounting (Horizontal Impulse Piping Type)

Vertical pipe mounting (Process connector upside) Vertical pipe mounting (Process connector downside)

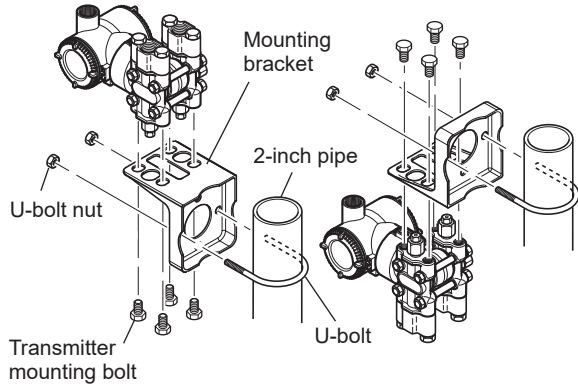

■ In the case of position adjustable bracket

Vertical pipe mounting (Process connector upside) Vertical pipe mounting (Process connector downside)

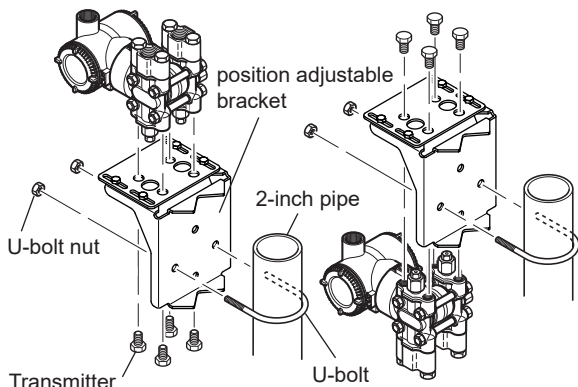

F0503.ai

Figure 5.3 Transmitter Mounting (Vertical Impulse Piping Type)

5.2.1 How to install the position adjustable bracket

The procedures for mounting the transmitter with the position adjustable bracket (L type) are described below. (See figure 5.4)

- (1) Securely fix the transmitter and the position adjustable plate using the transmitter mounting bolts. Tighten the transmitter mounting four bolts with a torque of approximately 39 N·m {4 kgf·m}.
- (2) Attach the bracket to the 2-inch pipe while adjusting the height to the process piping.
- (3) Loosen the position adjustment screw and slide the position adjustable plate on the bracket to align the position of the 2-inch pipe and the process piping.* 1
- (4) Tighten each of the position adjustment four bolts to firmly fix the position adjustable plate and the bracket. After fixing, check that it does not move.

Process connection upside

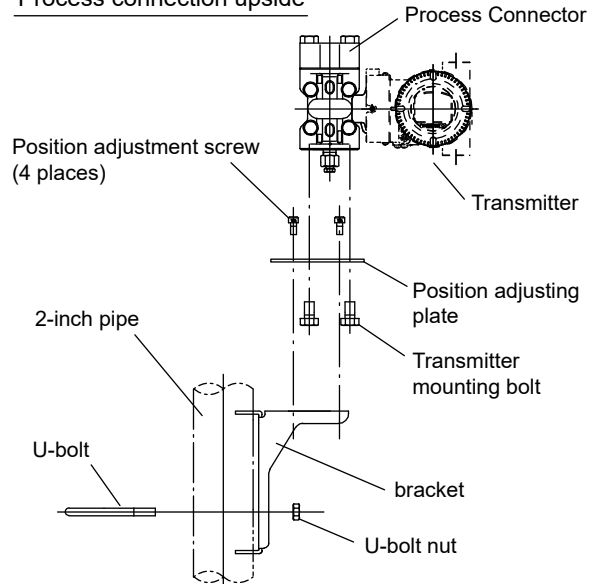

Process connection downside

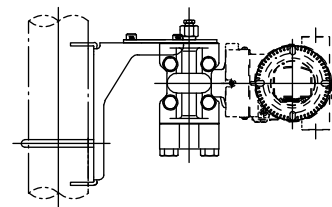

Mount the bracket in the direction as described in the figure.

F0509.ai

Figure 5.4 Mounting with the position adjustable bracket

- *1: The position adjustment plate can be adjusted in the range of 75 to 132 mm depending on the mounting direction to the bracket. The adjustment range varies depending on the model and specifications. (See figures 5.5 to 5.6)
- *2: When the EJX930A specified as “process connector downside”, the position adjustment plate can be used only in the inverted state shown in figure 5.6.

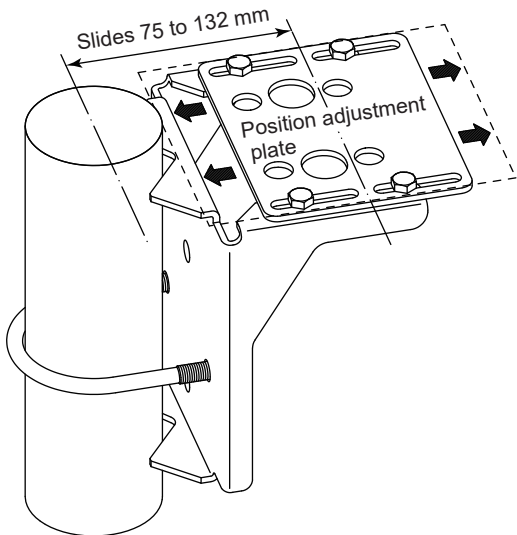

F0510.ai

Figure 5.5 Adjustable range of the plate

	The state of the plate seen from the above	The state of the plate seen from the side (EJX910A)	
Plate in minimum position (75 mm)			
Plate in maximum position (110 mm)			
Inverted plate in maximum position (132 mm)			

F0511.ai

Figure 5.6 The adjustable range by the mounting direction of the plate

5.3 Changing the Process Connection

The transmitter is shipped with the process connection specified at the time of ordering. To change the process connection, the drain (vent) plug must be repositioned.

To reposition a drain (vent) plug, use a wrench to slowly and gently unscrew it. Then, remove and remount it on the opposite side. Wrap sealing tape around the drain (vent) plug threads (*1 in the figure below), and apply a lubricant to the threads of the drain (vent) screw(s) (*2 below). To tighten the drain (vent) plugs, apply a torque of 34 to 39 N·m {3.5 to 4 kgf·m}. Process connector bolts are to be tightened uniformly to a torque of 39 to 49 N·m {4 to 5 kgf·m}.

Vertical impulse piping type Horizontal impulse piping type

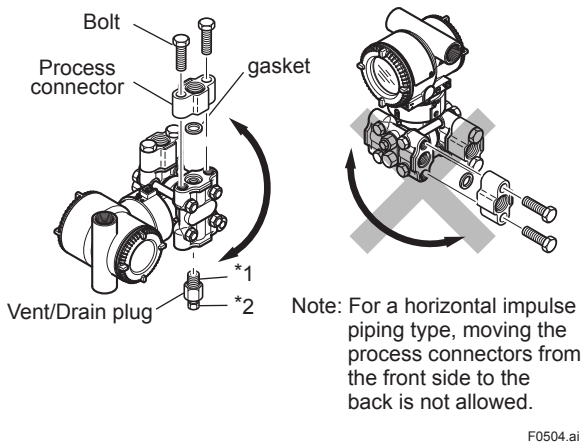

Figure 5.7 Changing Process Connection

5.4 Swapping the High/Low-pressure Side Connection

5.4.1 Rotating Pressure-detector Section 180°

This procedure can be applied only to a transmitter with a vertical impulse piping type.

The procedure below can be used to turn the pressure detector assembly 180°. Perform this operation in a maintenance shop with the necessary tools laid out and ready for use, and then install the transmitter in the field after making the change.

- 1) Use an Allen wrench (JIS B4648, nominal 2.5 mm) to remove the two setscrews at the joint between the pressure-detector section and transmitter section.
- 2) Leaving the transmitter section in position, rotate the pressure-detector section 180°.
- 3) Tighten the two setscrews to fix the pressure-detector section and transmitter section together (at a torque of 1.5 N·m).

Reposition the process connector and drain (vent) plugs to the opposite side as described in subsection 4.3.

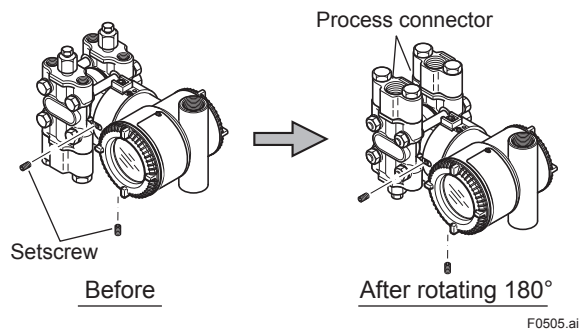

Figure 5.8 Before and After Modification

5.4.2 Using the Communicator

With a communicator, you can change which process connection is used as the high-pressure side without mechanically rotating the pressure-detector section 180 as described in subsection 5.4.1. To change, call parameter 'H/L swap' for HART Communication and select REVERSE (right side: low pressure; left side: high pressure) or select NORMAL to change back to normal (right side: high pressure; left side: low pressure). For other communication type except HART Communication Type, refer to each communication manuals.

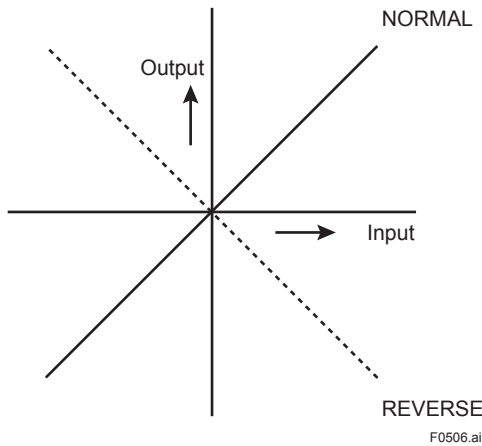

Figure 5.9 Input/Output Relationship



IMPORTANT

Since the H/L label plate on the capsule assembly will remain unchanged, use this function only when you cannot switch the impulse piping. If the 'H/L SWAP' parameter setting is changed, the input/output relationship is reversed as shown in figure 5.9; be sure this is understood by all.

5.5 Rotating Transmitter Section

The transmitter section can be rotated approximately 360° and can be fixed at any angle within the above range. (The direction of the rotation is depending on the configuration of the instrument.) Note that there is a stopper which prevents the transmitter section from being rotated more than 360°.

- 1) Remove the two setscrews that fasten the transmitter section and capsule assembly, using the Allen wrench.
- 2) Rotate the transmitter section slowly and stop it at designated position.
- 3) Tighten the two setscrews to a torque of 1.5 N·m.



WARNING

In the case of the explosion-proof/flameproof type transmitter, do not rotate the transmitter part in the hazardous area while the transmitter is energized.



IMPORTANT

Do not rotate the transmitter section more than the above limit.

Vertical impulse piping type

Pressure-detector section

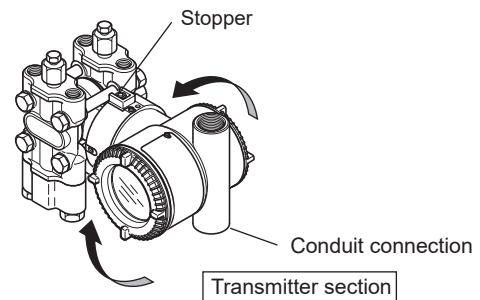

Horizontal impulse piping type

Transmitter section

Conduit connection

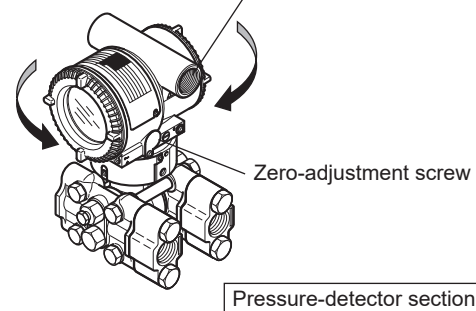

F0507.ai

Figure 5.10 Rotating Transmitter Section (Left Side High Pressure Type)

5.6 Changing the Direction of Integral Indicator



IMPORTANT

Always turn OFF power, release pressure and remove a transmitter to non-hazardous area before disassembling and reassembling an indicator.

An integral indicator can be installed in the following three directions. Follow the instructions in section 9.4 for removing and attaching the integral indicator.

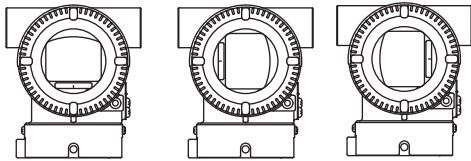

F0508.ai

Figure 5.11 Integral Indicator Direction

6. Installing Impulse Piping

6.1 Impulse Piping Installation Precautions

The impulse piping that connects the process outputs to the transmitter must convey the process pressure accurately. If, for example, gas collects in a liquid-filled impulse line, or the drain for a gas-filled impulse line becomes plugged, it will not convey the pressure accurately. Since this will cause errors in the measurement output, select the proper piping method for the process fluid (gas, liquid, or steam). Pay careful attention to the following points when routing the impulse piping and connecting the impulse piping to a transmitter.

6.1.1 Connecting Impulse Piping to a Transmitter

(1) Check the High and Low Pressure Connections on the Transmitter (figure 6.1)

Symbols “H” and “L” have been placed on the capsule assembly to indicate high and low pressure side. With differential pressure transmitters, connect the high pressure side impulse line to the “H” side, and the low pressure side impulse line to the “L” side.

When the option code /BS is specified, impulse piping cannot be connected to the “L” side.

Differential Pressure Transmitter

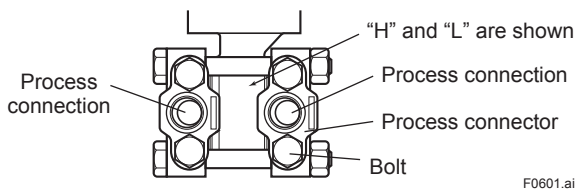

Figure 6.1 “H” and “L” Symbols on a Capsule Assembly

(2) Changing the Process Connector Piping Connections (figure 5.1)

The impulse piping connection distances can be changed between 51 mm, 54 mm and 57 mm by changing the orientation of the process connectors. This is convenient for aligning an impulse line with a process connectors.

(3) Tightening the Process Connector Mounting Bolts

After connecting an impulse line, tighten the process connector mounting bolts uniformly.

(4) Removing the Impulse Piping Connecting Port Dustproof Cap

The impulse piping connecting port on the transmitter is covered with a plastic cap to keep out dust. This cap must be removed before connecting the line. (Be careful not to damage the threads when removing this cap. Never insert a screwdriver or other tool between the cap and port threads to remove the cap.)

(5) Connecting the Transmitter and 3-Valve Manifold

A 3-valve manifold consists of two stop valves to block process pressure and an equalizing valve to equalize the pressures on the high and low pressure sides of the transmitter. Such a manifold makes it easier to disconnect the transmitter from the impulse piping, and is convenient when adjusting the transmitter zero point.

There are two 3-valve manifold types: the pipe-mounting type and the direct-mounting type; care should be taken with respect to the following points when connecting the manifold to the transmitter.

■ Pipe-Mounting Type 3-Valve Manifold (figure 6.2)

- 1) Screw nipples into the connection ports on the transmitter side of the 3-valve manifold, and into the impulse piping connecting ports on the process connectors. (To maintain proper sealing, wind sealing tape around the nipple threads.)
- 2) Mount the 3-valve manifold on the 2-inch pipe by fastening a U-bolt to its mounting bracket. Tighten the U-bolt nuts only lightly at this time.
- 3) Install the pipe assemblies between the 3-valve manifold and the process connectors and lightly tighten the ball head lock nuts. (The ball-shaped ends of the pipes must be handled carefully, since they will not seal properly if the ball surface is scratched or otherwise damaged.)

- 4) Now tighten the nuts and bolts securely in the following sequence:
 Process connector bolts → transmitter-end ball head lock nuts → 3-valve manifold ball head lock nuts → 3-valve manifold mounting bracket U-bolt nuts

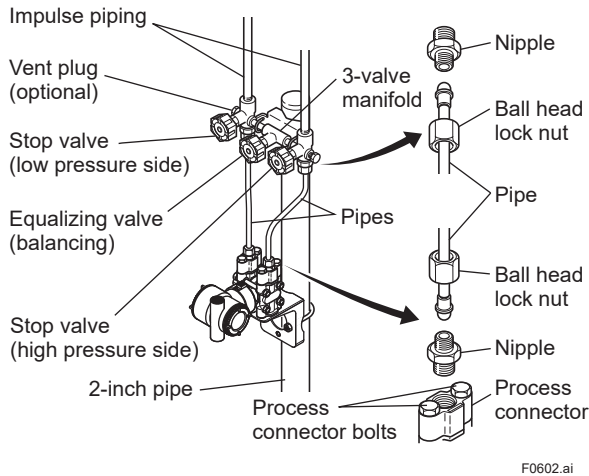

F0602.ai

Figure 6.2 3-Valve Manifold (Pipe-Mounting Type)

■ Direct-Mounting Type 3-Valve Manifold (figure 6.3)

- 1) Mount the 3-valve manifold on the transmitter. (When mounting, use the two gaskets and the four bolts provided with the 3-valve manifold. Tighten the bolts evenly.)
- 2) Mount the process connectors and gaskets on the top of the 3-valve manifold (the side on which the impulse piping will be connected).

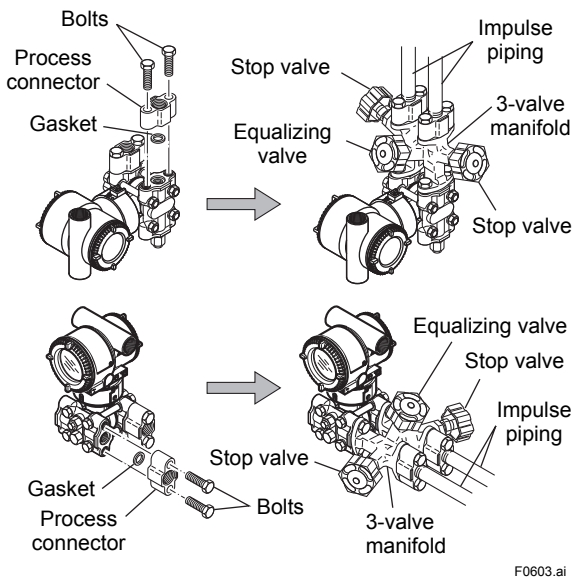

F0603.ai

Figure 6.3 3-Valve Manifold (Direct-Mounting Type)



NOTE

After completing the connection of the transmitter and 3-valve manifold, be sure to CLOSE the low pressure and high pressure stop valves, OPEN the equalizing valve, and leave the manifold with the equalizing valve OPEN.

You must do this in order to avoid overloading the transmitter from either the high or the low pressure side when beginning operation.

This instruction must also be followed as part of the startup procedure (chapter 8.)

6.1.2 Routing the Impulse Piping

(1) Process Pressure Tap Angles

If condensate, gas, sediment or other extraneous material in the process piping gets into the impulse piping, pressure measurement errors may result. To prevent such problems, the process pressure taps must be angled as shown in figure 6.4 according to the kind of fluid being measured.



NOTE

- If the process fluid is a gas, the taps must be vertical or within 45° either side of vertical.
- If the process fluid is a liquid, the taps must be horizontal or below horizontal, but not more than 45° below horizontal.
- If the process fluid is steam or other condensing vapor, the taps must be horizontal or above horizontal, but not more than 45° above horizontal.

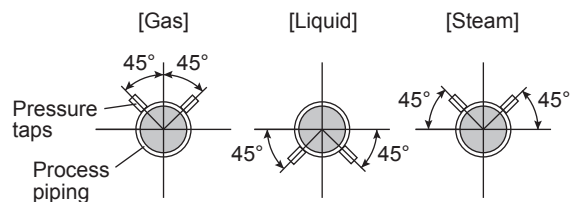

F0604.ai

Figure 6.4 Process Pressure Tap Angle (For Horizontal Piping)

(2) Position of Process Pressure Taps and Transmitter

If condensate (or gas) accumulates in the impulse piping, it should be removed periodically by opening the drain (or vent) plugs. However, this will generate a transient disturbance in the pressure measurement, and therefore it is necessary to position the taps and route the impulse piping so that any extraneous liquid or gas generated in the leadlines returns naturally to the process piping.

- If the process fluid is a gas, then as a rule the transmitter must be located higher than the process pressure taps.
- If the process fluid is a liquid or steam, then as a rule the transmitter must be located lower than the process pressure taps.

(3) Impulse Piping Slope

The impulse piping must be routed with only an upward or downward slope. Even for horizontal routing, the impulse piping should have a slope of at least 1/10 to prevent condensate (or gases) from accumulating in the pipes.

(4) Temperature Difference Between Impulse Lines

If there is a temperature difference between the high and low impulse lines, the density difference of the fluids in the two lines will cause an error in the measurement pressure. When measuring flow, impulse lines must be routed together so that there is no temperature difference between them.

(5) Condensate Pots for Steam Flow Measurement

If the liquid in the impulse piping repeatedly condenses or vaporizes as a result of changes in the ambient or process temperature, this will cause a difference in the fluid head between the high pressure and low pressure sides. To prevent measurement errors due to these head differences, condensate pots are used when measuring steam flow.

(6) Preventing Wind Speed Effects in Very Low Differential Pressure Measurement



IMPORTANT

When using a differential pressure transmitter to measure very low pressures (draft pressure), the low pressure connection port is left open to atmospheric pressure (the reference pressure). Any wind around the differential pressure transmitter will therefore cause errors in the measurement. To prevent this, it will be necessary either to enclose the transmitter in a box, or to connect an impulse line to the low pressure side and insert its end into a wind-excluding pot (cylindrical with a base plate).

(7) Preventing Freezing

If there is any risk that the process fluid in the impulse piping or transmitter could freeze, use a steam jacket or heater to maintain the temperature of the fluid.



NOTE

After completing the connections, close the valves on the process pressure taps (main valves), the valves at the transmitter (stop valves), and the impulse piping drain valves, so that condensate, sediment, dust and other extraneous material cannot enter the impulse piping.

6.2 Impulse Piping Connection Examples

Figure 6.5 shows examples of typical impulse piping connections. Before connecting the transmitter to the process, study the transmitter installation location, the process piping layout, and the characteristics of the process fluid (corrosiveness, toxicity, flammability, etc.), in order to make appropriate changes and additions to the connection configurations.

Note the following points when referring to these piping examples.

- The high pressure connecting port on the transmitter is shown on the right (as viewed from the front).
- The transmitter impulse piping connection is shown for a vertical impulse piping connection configuration in which the direction of connection is either upwards or downwards.
- If the impulse line is long, bracing or supports should be provided to prevent vibration.
- The impulse piping material used must be compatible with the process pressure, temperature, and other conditions.
- A variety of process pressure tap valves (main valves) are available according to the type of connection (flanged, screwed, welded), construction (globe, gate, or ball valve), temperature and pressure. Select the type of valve most appropriate for the application.

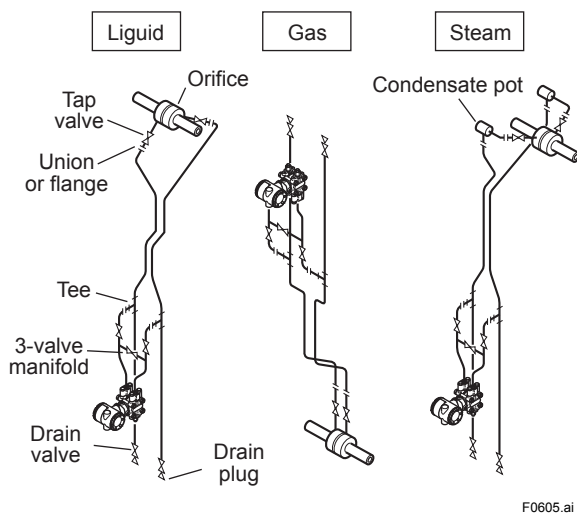

Figure 6.5 Impulse Piping Connection Example

7. Wiring

7.1 Wiring Precautions



IMPORTANT

- The information in the sections from 7.2 through 7.5 (except for 7.5.2) is specific to HART communication type. Refer to IM01C25R03-01E for FOUNDATION Fieldbus protocol type or IM 01C25R05-01EN for Modbus Communication Type.
- Lay wiring as far as possible from electrical noise sources such as large capacity transformers, motors, and power supplies.
- Remove the electrical connection dust cap (plug) before wiring.
- All threaded parts must be treated with waterproofing sealant. (A non-hardening silicone group sealant is recommended.)
- To prevent noise pickup, do not pass signal and power cables through the same ducts.
- Explosion-protected instruments must be wired in accordance with specific requirements (and, in certain countries, legal regulations) in order to preserve the effectiveness of their explosion-protected features.
- The terminal box cover is locked by an Allen head bolt (a shrouding bolt) on ATEX flameproof type transmitters. When the shrouding bolt is driven clockwise using an Allen wrench, it goes in. The cover lock can then be released and the cover can be opened by hand. See subsection 8.4 “Disassembly and Reassembly” for details.
- Plug and seal an unused conduit connection.
- Do not turn on power until all wirings including RTD finished.

7.2 Selecting the Wiring Materials

- Use stranded leadwires or cables which are the same as or better than 600 V grade PVC insulated wire or its equivalent.
- Use shielded wires in areas that are susceptible to electrical noise.
- In areas with higher or lower ambient temperatures, use appropriate wires or cables.
- In environment where oils, solvents, corrosive gases or liquids may be present, use wires or cables that are resistant to such substances.
- It is recommended that crimp-on solderless terminal lugs (for 4 mm screws) with insulating sleeves be used for leadwire ends.

7.3 Types of Output

Table 7.2 shows the wiring example according to the output types.

(1) Analog Output (4 to 20 mA DC)

This instruments uses the same two wires for both, the signal and power supply. A DC power supply is required in a transmission loop. The total leadwire resistance including the instrument load and power distributor (supplied by the user) must conform to a value in the permissible load resistance range. Refer to figure below.

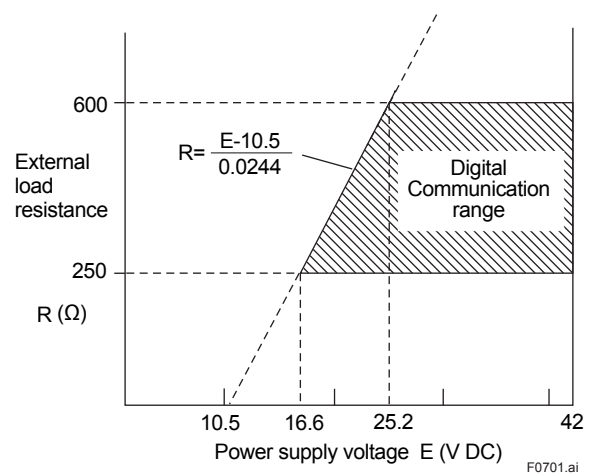

Figure 7.1 Relation between Power Supply Voltage and Load Resistance (4 to 20 mA DC Output)

(2) Pulse output and Alarm, Status Output

This instruments uses three wires between the converter and the power supply.

A DC power and load resistance are required, and pulse output is connected to a totalizer or an electric counter.

Low level of the pulse output is 0 to 2V. No communication is possible over a transmission line.

(3) Simultaneous Analog-Pulse Output

When using the simultaneous analog-pulse output mode, the communicable distance of the transmission line is restricted on the wiring method.

Table 7.2 shows the examples of connection for this output mode.

IMPORTANT

For pulse output and the simultaneous analog-pulse output, use the load resistance. Refer to Table 7.2.

7.4 Connection

7.4.1 Power Supply Wiring Connection

IMPORTANT

Connecting with the commercial AC power supply will damage the device. Be sure to use the DC power supply in the predetermined range.

Table 7.2 shows the wiring example according to the output types.

7.4.2 External Indicator Connection

Connect wiring for external indicators to the CHECK A (+) and SUPPLY – terminals.

(Note) Use a external indicator whose internal resistance is 10Ω or less.

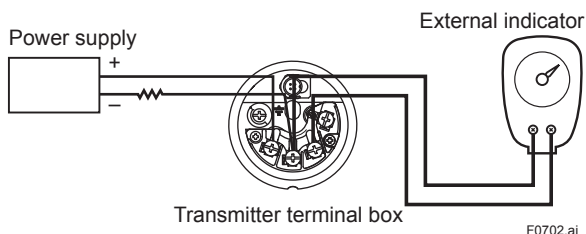

Figure 7.2 External Indicator Connection

7.4.3 Communicator Connection

Connect the HART Hand Held Terminal (HHT) to the SUPPLY + and – terminals.

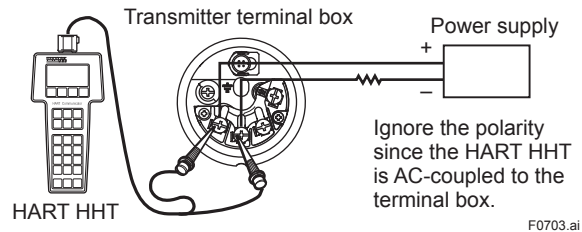

Figure 7.3 HART HHT Connection

7.4.4 Check Meter Connection

Connect the check meter to the CHECK A (+) and SUPPLY – terminals. (Use hooks.)

- A 4 to 20 mA DC output signal from the CHECK A (+) and SUPPLY – terminals.

(Note) Use a check meter whose internal resistance is 10 or less.

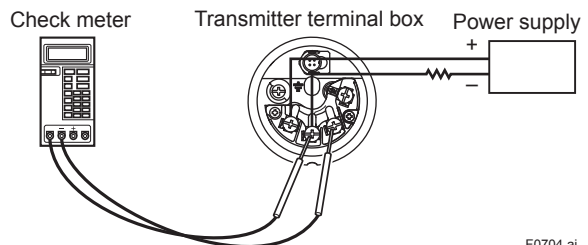

Figure 7.4 Check Meter Connection

7.4.5 External Temperature Connection

Connect the RTD cable assembly to the Juck Terminal.

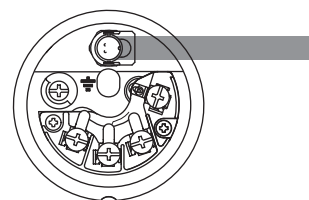

Figure 7.5 External temperature Connection

7.5 Wiring

7.5.1 Loop Configuration

(1) General-use Type and Flameproof Type

- **Analog Output**

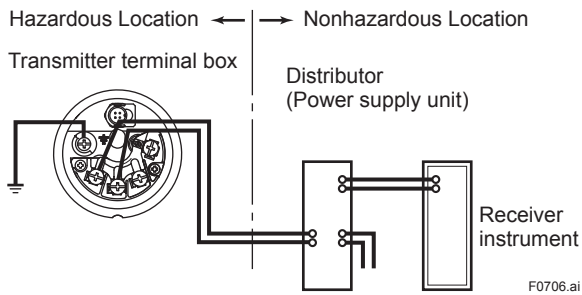

- **Pulse output and Alarm, Status Output or Simultaneous Analog-Pulse Output**

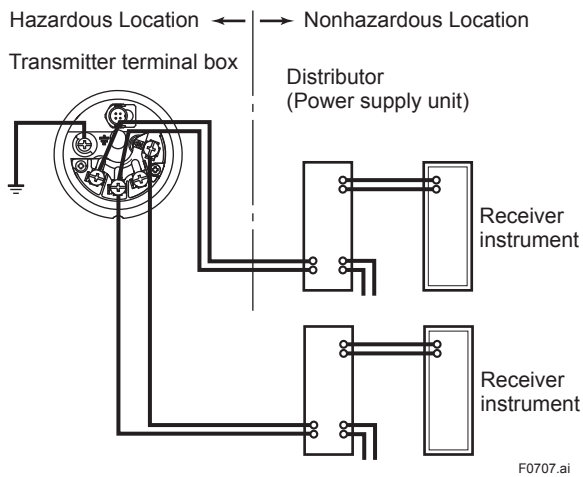
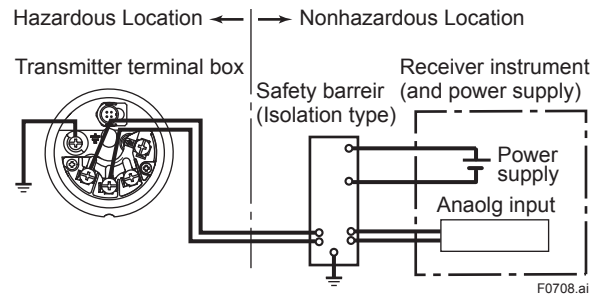

Figure 7.6 Connection between Transmitter and Distributor

(2) Intrinsically Safe Type

With the intrinsically safe type, a safety barrier must be included in the loop. Followings are wiring examples.

- **Analog Output**



- **Simultaneous Analog-Pulse Output**

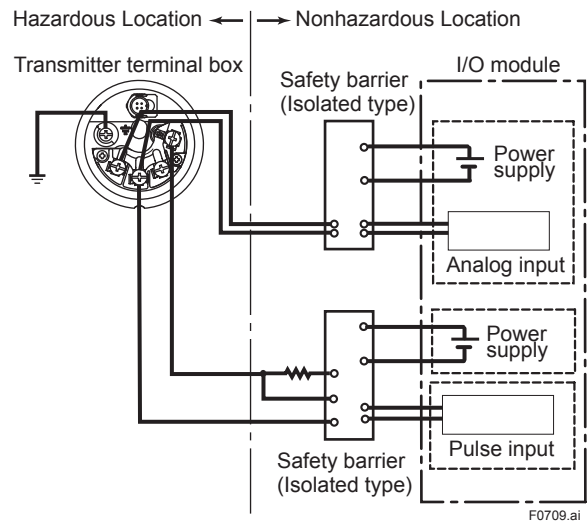

Figure 7.7 Connection between Transmitter, barrier and receiver

7.5.2 Wiring Installation

(1) General-use Type and Intrinsically Safe Type

With the cable wiring, use a metallic conduit or waterproof glands.

- Apply a non-hardening sealant to the terminal box connection port and to the threads on the flexible metal conduit for waterproofing.

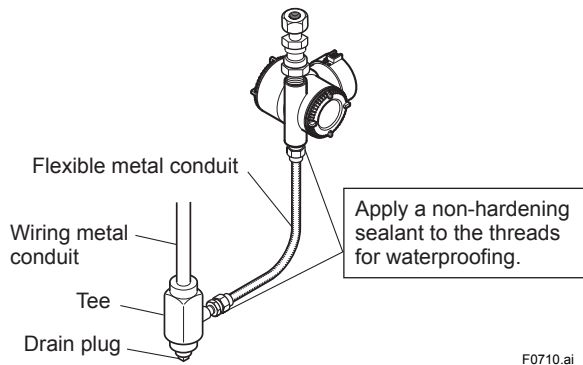

F0710.ai

Figure 7.8 Typical Wiring Using Flexible Metal Conduit

(2) Flameproof Type

Wire cables through a flameproof packing adapter, or use a flameproof metal conduit.

- Wiring cable through flameproof packing adapter.
 - Apply a non-hardening sealant to the terminal box connection port and to the threads on the flameproof packing adapter for waterproofing.

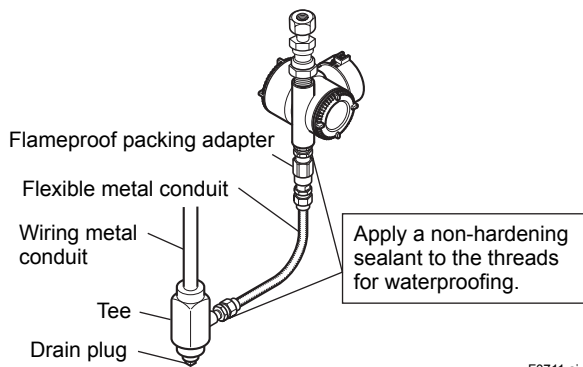

F0711.ai

Figure 7.9 Typical Cable Wiring Using Flameproof Packing Adapter

- Flameproof metal conduit wiring
 - A seal fitting must be installed near the terminal box connection port for a sealed construction.
 - Apply a non-hardening sealant to the threads of the terminal box connection port, flexible metal conduit and seal fitting for waterproofing.

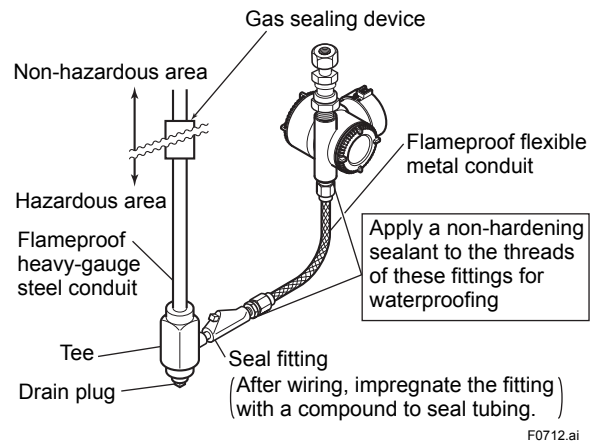

F0712.ai

Figure 7.10 Typical Wiring Using Flameproof Metal Conduit

7.6 RTD Cable Connection

Connection of the RTD cable is always required to measure external temperature. Follow the procedures below to connect and disconnect a cable when a cable gland or a conduit is used.

7.6.1 Connecting Shielded Cable with Cable Gland (External temperature input code: -1, -2, -3, and -4)

CAUTION

- When the option code: PF22, PF23, NF2, NF21, UF1, GF11, GF12, GU11 or GU12 is selected, cable glands for RTD cable are not attached.
- For these option, prepare the cable gland conform to the cable of $\varnothing 8.5\text{mm}$ diameter. In the case to insert the RTD cable into cable gland from the side of RTD connector, inner diameter of the cable gland must be larger than $\varnothing 13\text{mm}$. If the inner diameter of selected cable gland is smaller than $\varnothing 13\text{mm}$, insert the RTD cable from the opposite side of the RTD connector before laying RTD cable.

- RTD connection components: EJX multivariable transmitter, two cable glands, and RTD cable. Two cable glands are attached.

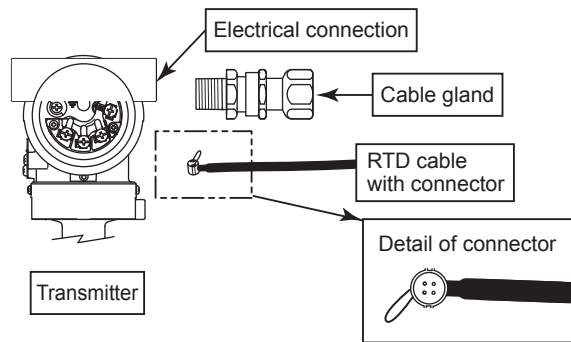

F0713.ai

- Magnified view of the RTD connector in the transmitter's terminal box.

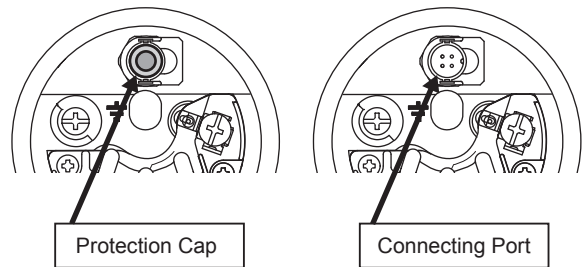

F0714.ai

The RTD cable connecting port is covered with a cap to keep out dust. The cap should not be removed until you are ready to install the cable.

CAUTION

Input/output signal is non-isolated.
Do not turn on power supply until you complete all the wiring work.

■ In the case of electrical connection code 2 (1/2NPT female) or 4 (M20 female).

- Components for the cable gland
The cable gland assembly consists of an entry, seal, running coupler, and backnut. Confirm that the seal is attached inside the entry and that the thread size of the cable gland is the same as that for the RTD electrical connection.

1/2NPT Type

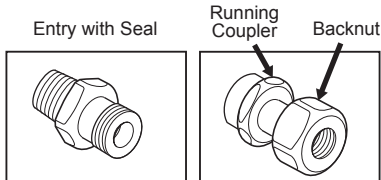

M20 Type

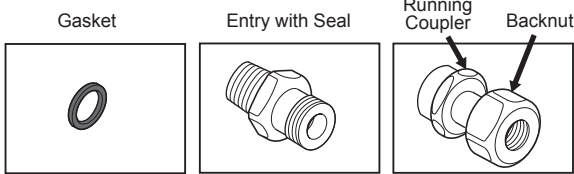

Procedure

- (1) Pass the RTD cable through the cable gland from the cable end of the wire rods side (opposite side of RTD connector).

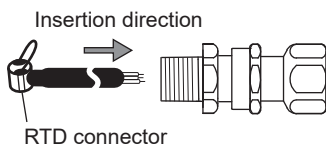

F0729.ai

- (2) Remove the protection cap over the transmitter electrical connection and install the entry on the electrical connection. Note that a non-hardening sealant should be applied to the threads for a 1/2 NPT connection and a gasket should be used for an M20 connection.

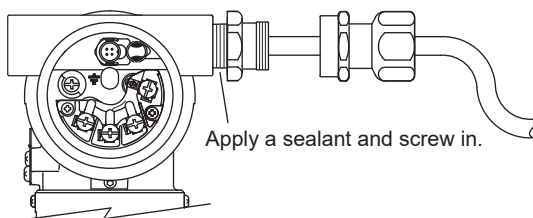

F0716.ai

- (3) Insert the RTD cable and firmly plug its connector into the connecting port in the transmitter's terminal box.

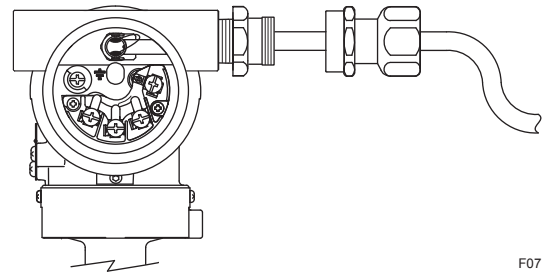

F0718.ai

- (4) Align the running coupler on the entry.

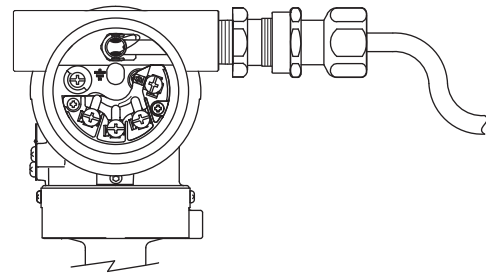

F0719.ai

- (5) Turn the running coupler until the seal in the entry comes into contact with the RTD cable.

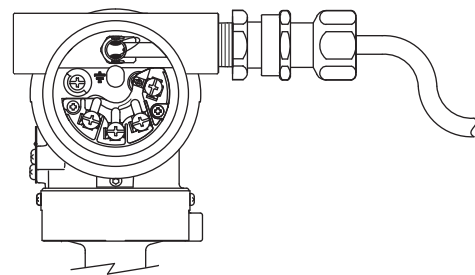

F0720.ai

- (6) Rotate the running coupler another half turn to securely tighten the seal on the RTD cable.
- (7) Use a protection conduit, if necessary. In this case, insert the cable through the conduit and attach it to the Backnut.

CAUTION

After the cable is secured as explained above, do not tighten the running coupler any further; to do so could damage the RTD connection. Do not pull the cable or subject it to excessive mechanical shock.

■ In the case of electrical connection code F (G1/2 female).

- Components for the cable gland
The cable gland assembly consists of an adapter body, packing box, rubber packing, washer, gland, clamp ring, clamp nut, union coupling, and union cover.
Refer to (2) and (3) shown below.
RTD cable gland is accompanied by two kinds of rubber packing.
Since the outside diameter of the RTD cable is 8.5 mm, use the rubber packing with identification mark "16 8-10" on it.

 **NOTE**

The RTD cable can not let through the cable gland from the connector side.
Insert the cable through the cable gland from the wire rods side (opposite side of RTD connector) before laying the cable.

Procedure

- (1) Disassemble the cable gland: loosen the all parts
- (2) Remove the protection cap on the RTD electrical connection and RTD connecting port, and screw the adapter body to the RTD electrical connection.
Screw the adapter body into the RTD electrical connection until the O-ring touches the RTD electrical connection (at least 6 full turns), and firmly tighten the lock nut by the wrench.

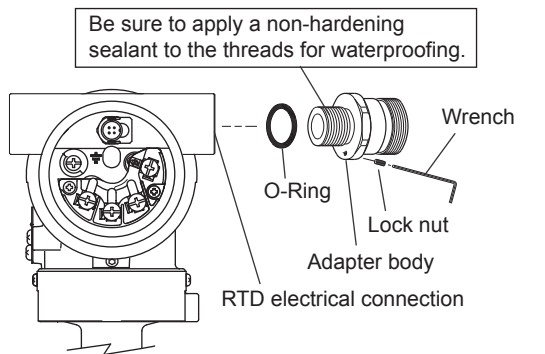

F0726.ai

- (3) Insert the RTD cable in order of a packing box, rubber packing, washer, gland, clamp ring, clamp nut, union coupling, union cover from the cable end of the wire rods side (opposite side of RTD connector).
Since the internal diameter of rubber packing has restriction, RTD connector can not pass through it, please keep this order.

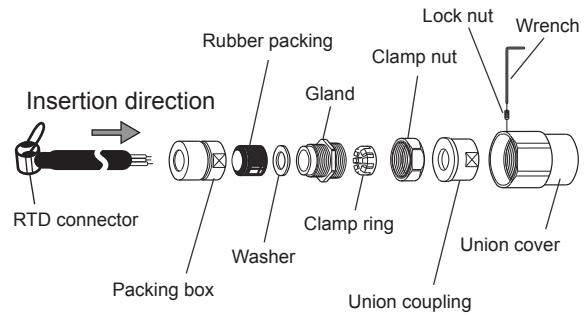

F0727.ai

- (4) Secure the RTD cable to the packing box by screwing the gland into the packing box at the position where the distance from the connector tip of the RTD cable to the packing box will be 56.5 ± 1 mm.
Tighten approximately 1 more turn surely after the cable can not move.
The quantity of this tightening is very important. It leads to wiring disconnection fault when tighten too much.
After that, tighten the clamp nut.

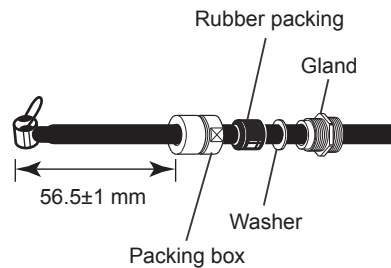

F0728.ai

- (5) Insert the RTD cable and firmly plug its connector into the connecting port in the transmitter's terminal box.
- (6) Screw the union cover to the adaptor body which has fixed to the RTD electrical connection at procedure (2).
Screw the union cover at least 6 full turns, and tighten the rock nut.
- (7) If the conduit piping is necessary, screw the conduit to the union coupling after passing the RTD cable through the conduit.
- (8) Finally, confirm whether the connector is plugged surely.

 **CAUTION**

After the cable is plugged as explained above, do not pull the cable or subject it to excessive mechanical shock.
Finally, please remember to confirm whether the connector is plugged surely.

7.6.2 Connecting Shielded Cable for Conduit Use (External temperature input code: -B, -C, and -D)

- RTD connection components: EJX multivariable transmitter and RTD cable

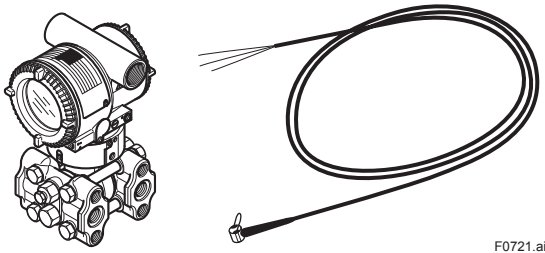

F0721.ai

Procedure

- (1) Remove the protection cap protecting the RTD electrical connection and insert the RTD cable.

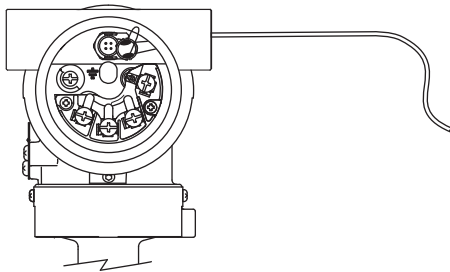

F0722.ai

- (2) Remove the cap protecting the connecting port. Then insert the RTD cable and firmly plug the connector into the connecting port in the transmitter's terminal box.
- (3) Insert the cable through the conduit and attach it to the RTD electrical connection.

 **CAUTION**

Do not pull the cable or subject it to excessive mechanical shock.

7.6.3 Removing Shielded Cable with Cable Gland (External temperature input code: -1, -2, -3, and -4)

- (1) By pulling out the string attached to the connector, carefully unplug the connector from the transmitter's connecting port.
- (2) In the case of using 1/2NPT Type or M20 Type cable gland, remove the running coupler and backnut assembly by turning the running coupler.
In the case of using G1/2 Type cable gland, loosen the lock nut screwed into the union cover and remove the union cover. RTD cable can be pulled out together with the packing box. Loosen the clamp nut and the gland if necessary.
- (3) Pull the RTD cable out carefully.
- (4) In the case of 1/2NPT Type or M20 Type cable gland, remove the entry from the RTD electrical connection by turning the entry before (3).
In the case of G1/2 Type cable gland, loosen the lock nut screwed into the adapter body and remove the adapter body.



NOTE

In the case of G1/2 Type cable gland, remove the rubber packing, washer, gland, clamp ring, clamp nut, union coupling and union cover from the opposite side of RTD connector in order to take out the cable gland from the RTD cable.

7.6.4 Removing Shielded Cable for Conduit Use (External temperature input code: -B, -C, -D)

- (1) By pulling out the string attached to the connector, slowly unplug the connector from the transmitter's connecting port.
- (2) Remove the conduit from the RTD electrical connection.
- (3) Pull the RTD cable out through the RTD electrical connection.

7.6.5 Cable Connection RTD Terminal Box Side

EJX multivariable transmitter RTD I/F is for 3-wire Type RTD, Pt100.

Heed the following when wiring an RTD of the 2- or 4-wire type.

 **NOTE**

Please note that a temperature error will occur when you use a 2-wire RTD because of wiring resistance.

Please do not ground the shield on the RTD side of the cable.

 **CAUTION**

Please use only the cables provided with this instrument.

When wiring, be sure not to damage the cable's insulation or its core.

All the cable cores must have sufficient insulation around them.

Do not let the signal line contact the shield line.

Do not allow the shield line or the signal line to come the earth potential voltage.

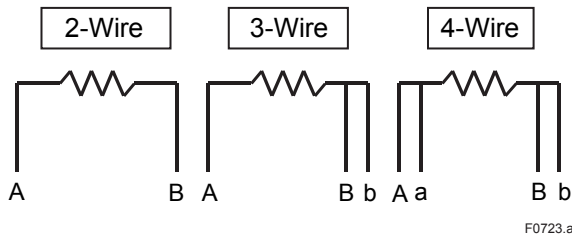

Figure 7.11 The Method of Wiring for the RTD Side

Table 7.1 The Method of Wiring for the RTD Side RTD Terminal

RTD Terminal	A	a	B	b
2-Wire	White	–	Blue1 and Blue2	–
3-Wire	White	–	Blue1	Blue2
4-Wire	White	open	Blue1	Blue2

 **NOTE**

The color display in the table shows the white line of the cable.

The cable color could change depending on the cable type.

Blue1 and blue2 allow changing places.

For 2-wire Type, connect either which is blue1 or blue2, and give other side as OPEN.

7.7 Grounding

Grounding is always required for the proper operation of transmitters. Follow the domestic electrical requirements as regulated in each country. For a transmitter with a built-in lightning protector, grounding should satisfy ground resistance of 10Ω or less.

Ground terminals are located on the inside and outside of the terminal box. Either of these terminals may be used.

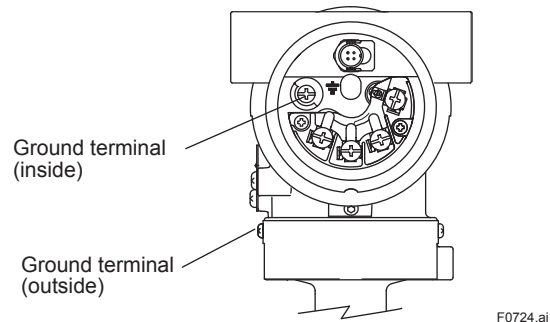
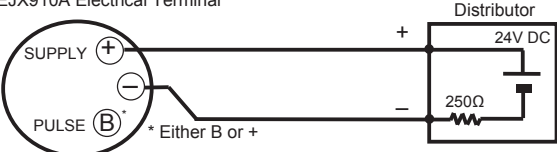
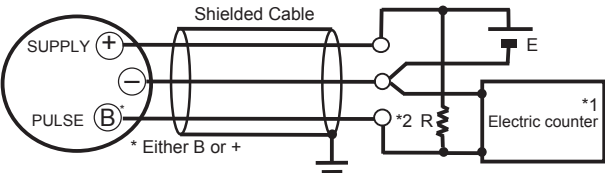
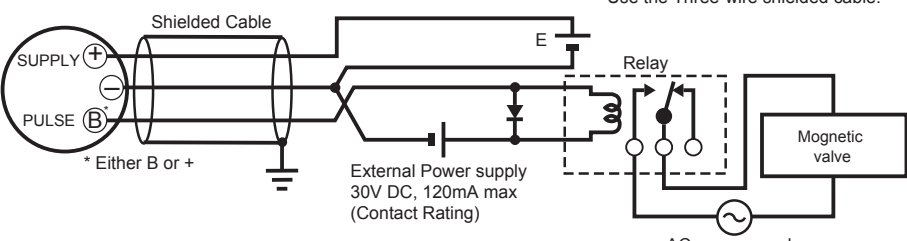
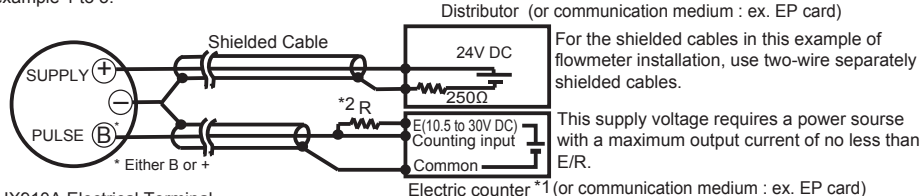
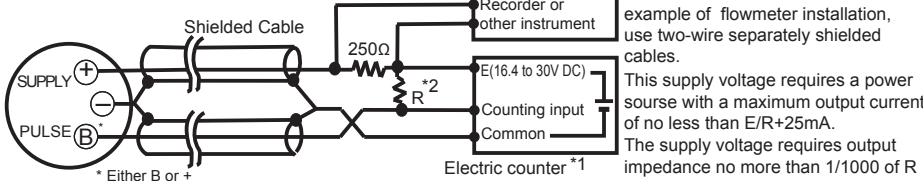
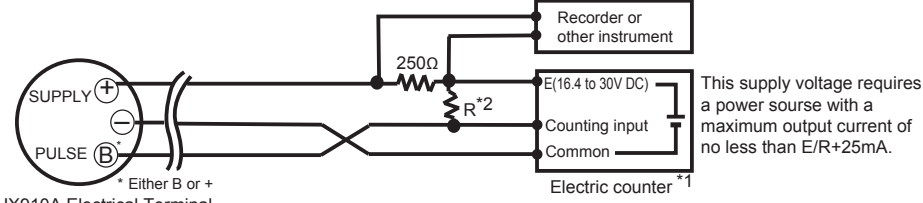

Figure 7.12 Ground Terminals (Eg. HART Communication Type)

**Table 7.2 The connection example for simultaneous analog and pulse and alarm, status output.
(For HART communication type)**

Connection	Description
<p>Analog Output</p> <p>In this case, Communication is possible (up to a distance of 2km when a CEV cable is used.)</p>	<p>EJX910A Electrical Terminal</p>  <p>* Either B or +</p>
<p>Pulse Output</p> <p>In this case, No communication is possible.</p>	<p>EJX910A Electrical Terminal</p> <p>Use the Three-wire shielded cable.</p>  <p>* Either B or +</p>
<p>Status Output</p> <p>In this case, No communication is possible.</p>	<p>EJX910A Electrical Terminal</p> <p>Use the Three-wire shielded cable.</p>  <p>* Either B or +</p> <p>External Power supply 30V DC, 120mA max (Contact Rating)</p> <p>AC power supply</p>
<p>Simultaneous Analog -Pulse Output *3</p> <p>Example 1 In this case, Communication is possible (up to a distance of 2km when a CEV cable is used).</p> <p>Example 2 In this case, Communication is possible (up to a distance of 200m when a CEV cable is used) and R = 1kΩ).</p> <p>Example 3 In this case, No communication is possible (when shielded cable is not used).</p>	<p>When analog and pulse output are used, the length of communication line is subjected to wiring conditions. Refer to example 1 to 3.</p> <p>Distributor (or communication medium : ex. EP card)</p>  <p>* Either B or +</p> <p>For the shielded cables in this example of flowmeter installation, use two-wire separately shielded cables.</p> <p>This supply voltage requires a power source with a maximum output current of no less than E/R.</p> <p>EJX910A Electrical Terminal</p>  <p>* Either B or +</p> <p>For the shielded cables in this example of flowmeter installation, use two-wire separately shielded cables.</p> <p>This supply voltage requires a power source with a maximum output current of no less than E/R+25mA.</p> <p>The supply voltage requires output impedance no more than 1/1000 of R (load resistance).</p> <p>EJX910A Electrical Terminal</p>  <p>* Either B or +</p> <p>This supply voltage requires a power source with a maximum output current of no less than E/R+25mA.</p>
<p>The range of load resistance R for the pulse output.</p>	<p>The load resistance of pulse output should be used to 1kΩ, 2W.</p> <p>If no translation of the pulse output possible by the cable length or the frequency of the pulse output, the load resistance should be selected by calculation as shown below.</p> $\frac{E (V)}{120} \leq R (k\Omega) \leq \frac{0.1}{C (\mu F) \times f (kHz)}$ <p>Example of CEV cable capacitance ≈ 0.1μF/km</p> $P (mW) = \frac{E^2 (V)}{R (k\Omega)}$ <p>Where E = Supply voltage (V) f = Frequency of pulse output (kHz) R = Value of load resistance (kΩ) C = Cable capacitance (μF) P = Power ratio of the load resistance (mW)</p>

*1: To avoid the influence of external noise, use an electric counter which fits to the pulse frequency.
*2: Resistor is not necessary in case of an electric counter which can receive contact pulse signal directly.
*3: When using analog and pulse output simultaneously, the HART communication may be influenced by noise comparing analog output only. Take countermeasure for noise shown above, e.g. use shield cable etc.

8. Operation



IMPORTANT

The information of transmitter configuration in the chapter 8 is specific to HART Communication type. For other Communication type except HART Communication Type, refer to each communication manuals.

8.1 Preparation for Starting Operation

This section describes the operation procedure for the EJX multivariable transmitter as shown in figure 8.1 (vertical impulse piping type, high-pressure connection: right side) when measuring the liquid flow rate.



NOTE

Check that the process pressure tap valves, drain valves, and 3-valve manifold stop valves on both the low pressure and high pressure sides are closed, and that the 3-valve manifold equalizing valve is opened.

- (a) Follow the procedures below to introduce process pressure into the impulse piping and transmitter.

■ Multivariable Transmitters

- 1) Open the low pressure and high pressure tap valves to fill the impulse piping with process liquid.
- 2) Slowly open the high pressure stop valve to fill the transmitter pressure-detector section with process liquid.
- 3) Close the high pressure stop valve.
- 4) Gradually open the low pressure stop valve and completely fill the transmitter pressure-detector section with process liquid.
- 5) Close the low pressure stop valve.
- 6) Gradually open the high pressure stop valve. At this time, equal pressure is applied to the low and high pressure sides of the transmitter.
- 7) Check that there are no liquid leaks in the impulse piping, 3-valve manifold, transmitter, or other components.

Venting Gas from the Transmitter Pressure-detector Section

- Since the piping in the example of figure 8.1 is constructed to be self-venting, no venting operation is required. If it is not possible to make the piping self-venting, refer to subsection 8.5 for instructions. Leave the equalizing valve open even after venting gas.
- (b) Turn ON power and connect the communicator. Open the terminal box cover, and connect the communicator to the SUPPLY + and – terminals.
 - (c) Using the communicator, confirm that the transmitter is operating properly. Check parameter values or change the setpoints as necessary.

See IM 01C25R02-01E (HART communication) for communicator operation.

If the transmitter is equipped with an integral indicator, its indication can be used to confirm that the transmitter is operating properly.

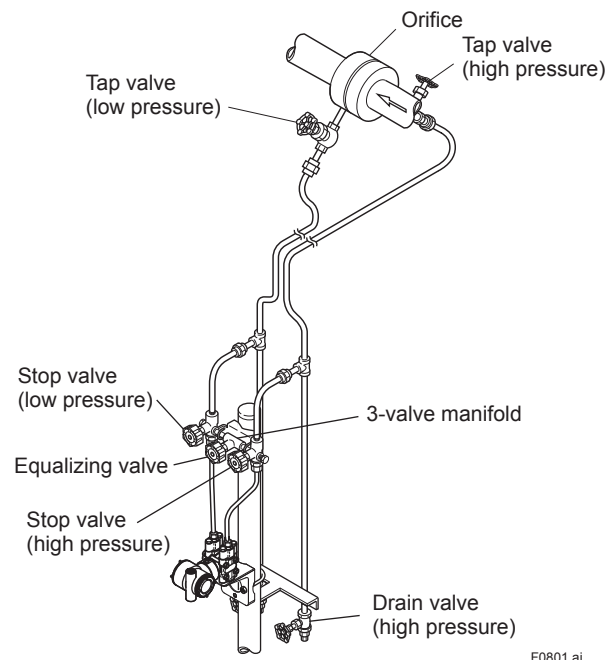

F0801.ai

Figure 8.1 Liquid Flow Measurement

■ **Confirming that Transmitter is Operating Properly**

Using the HART communicator

- If the wiring system is faulty, 'No device found at address O Poll' or communication error' appears on the display.
- If the transmitter is faulty, 'error message' appears on the display.

Using the integral indicator

- If the wiring system is faulty, the display stays blank.
- If the transmitter is faulty, an error code is displayed.



Self-diagnostic error on the integral indicator (Faulty transmitter)

F0802.ai

Figure 8.2 Integral Indicator with Error Code



NOTE

If any of the above errors are indicated on the display of the integral indicator or the communicator, refer to subsection 9.5.2 for the corrective action.

■ **Verify and Change Transmitter Parameter Setting and Values**

The parameters related to the following items are set at factory as specified in order.

- Calibration range
- Software damping (optional)

Other parameters like following are shipped with the default setting.

- Low-cut
- Process alarm setting
- Write protection

To confirm or change the values, see IM 01C25R02-01E or 01C25R03-01E.

8.2 Zero Point Adjustment

After completing preparations for operating the transmitter, adjust the zero point.

Zero point adjustment can be done by turning the transmitter's zero-adjustment screw or by using the communicator. This section describes the procedure for the zero-adjustment screw. For the communicator procedure, see the communication manual.



IMPORTANT

Do not turn off the power to the transmitter immediately after performing a zero point adjustment. Powering off within 30 seconds of performing this procedure will return the zero point to its previous setting.



NOTE

Before performing this adjustment, make sure that the external zero adjustment function has been enabled by a parameter setting. External zero adjustment function only to the differential pressure signal.

To check the output signal, use a digital multimeter, calibrator, or communicator.

8.2.1 Adjusting Zero Point for Differential Pressure

Before adjusting zero point, make sure that the equalizing valve is open.

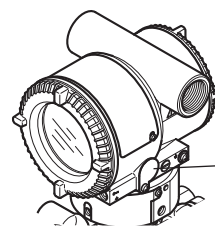

Zero-adjustment screw cover

F0803.ai

Figure 8.3 External Zero Adjustment Screw

The zero-adjustment screw is located inside the cover.

Use a slotted screwdriver to turn the zero-adjustment screw. Equalize the transmitter, then turn the screw clockwise to increase the output or counterclockwise to decrease the output. The zero point adjustment can be made with a resolution of 0.01% of the setting range. The degree of zero adjustments varies with the screw turning speed; turn the screw slowly to make a fine adjustment, quickly to make a rough adjustment.

8.2.2 Adjusting Zero Point for Static Pressure

Zero point adjustment for static pressure can be adjusted with the HART Communicator or FlowNavigator.

(1) When you can obtain the Low Range Value from the actual measured value of 0% (0 MPa pressure);

Apply zero pressure in % to the transmitter. After obtaining a stable pressure, adjust the zero point.

(2) When you cannot obtain the Low Range Value from the actual measured value of 0%;

Adjust the transmitter output to the actual measured value obtained by a highly accurate master meter such as digital manometer.

Example:
 Range: 0 to 16 MPa abs
 Actual measured value: 2.000 MPa abs
 Transmitter s output: 2.1 MPa abs
 Lower SP trim deviation
 (SP Manual Lower Pt): - 0.3 MPa abs

1. Device setup
 ↓
2. Diag/Service
 ↓
3. Calibration
 ↓
4. SP sensor trim
 ↓
1. SP trim

1

EJX-MV:YOKOGAWA
 SP trim mode:
 1 Off
 2 Auto, Lower Pt
 3 Auto, Upper Pt
 4 Manual Lower Pt
 5 Manual Upper Pt
 [ABORT] [ENTER]

[↓] ×3
 [F4]

ENTER (F4)

2 SP for trim is 2.1000
 Master meter shows 2.0 MPa abs
 <Calculation of error value>
 = 2.0-2.1
 = -0.1
 < Calculation of correction value>
 = The deviation value for SP zero adjustment
 + error value for SP zero adjustment
 = (-0.3)+(-0.1)
 =-0.4

EJX-MV:YOKOGAWA
 SP for trim 0.2100
 manual, Lower Pt
 -0.3000 MPa
 -0.4
 [DEL] [ABORT] [ENTER]

'-0.4'
 [F4]

(ENTER)

F0804.ai

8.2.3 Adjusting Zero Point for External Temperature

Zero point adjustment for external temperature can be adjusted by the HART Communicator or FlowNavigator.

As defined the reference resistor value table of the thermometer resistor (RTD), obtain resistance value corresponding to 0%, and use the obtained resistance as the input value, then deliver it to the transmitter by means of a variable resistor.

Measure the resulting output signal with the voltmeter (digital multimeter), and check the output value relative to the input value.

Zero point can be adjusted by the HART Communicator's easy key operation.

8.3 Starting Operation

After completing the zero point adjustment, follow the procedures below to start operation. Steps 1) and 2) are specific to the differential pressure transmitters.

- 1) Close the equalizing valve.
- 2) Gradually open the low pressure stop valve.
This places the transmitter in an operational condition.
- 3) Confirm the operating status. If the output signal exhibits wide fluctuations (hunting) due to periodic variation in the process pressure, use the communicator to dampen the transmitter output signal. Confirm the hunting using a receiving instrument or the integral indicator, and set the optimum damping time constant.
- 4) After confirming the operating status, perform the following.



IMPORTANT

- Remove the communicator from the terminal box, and confirm that none of the terminal screws are loose.
- Close the terminal box cover and the amplifier cover. Screw each cover in tightly until it will not turn further.
- There are two covers that must be locked on the ATEX Flameproof type transmitters. An Allen head bolt (shrouding bolt) under the edge of each cover is used to lock the cover. When the shrouding bolt is driven counterclockwise with an Allen wrench, the bolt rotates upward and locks the cover. (See section 9.4.) After locking the covers, confirm that they are secure and cannot be opened by hand.
- Tighten the zero-adjustment cover mounting screw to secure the cover.

8.4 Shutting Down the Transmitter

Shut down the transmitter as follows. Steps 2) and 3) are specific to the differential pressure transmitters.

- 1) Turn off the power.
- 2) Close the low pressure stop valve.
- 3) Open the equalizing valve.
- 4) Close the high pressure stop valve.
- 5) Close the high pressure and low pressure tap valves.



NOTE

- Whenever shutting down the transmitter for a long period, remove any process fluid that is in the transmitter pressure-detector section.
- The equalizing valve must be left OPEN.

8.5 Venting or Draining Transmitter Pressure-detector Section

Since this transmitter is designed to be self-draining and self-venting with vertical impulse piping connections, neither draining nor venting will be required if the impulse piping is configured appropriately for self-draining or self-venting operation.

If condensate (or gas) collects in the transmitter pressure-detector section, the measured pressure may be in error. If it is not possible to configure the piping for self-draining (or self-venting) operation, you will need to loosen the drain (vent) screw on the transmitter to completely drain (vent) any stagnated liquid (gas.)

However, since draining condensate or bleeding off gas disturbs the pressure measurement, this should not be done when the loop is in operation.



WARNING

Since the accumulated liquid (or gas) may be toxic or otherwise harmful, take appropriate care to avoid contact with the body, or inhalation of vapors.

8.5.1 Draining Condensate

- 1) Gradually open the drain screw or drain plug and drain the transmitter pressure-detector section. (See figure 8.4)
- 2) When all accumulated liquid is completely removed, close the drain screw or drain plug.
- 3) Tighten the drain screw to a torque of 10 N·m, and the drain plug to a torque of 34 to 39 N·m.

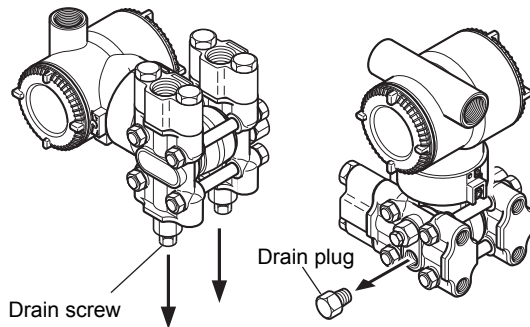

When you loosen the drain screw or drain plug, the accumulated liquid will be expelled in the direction of the arrow.

F0805.ai

Figure 8.4 Draining the Transmitter

8.5.2 Venting Gas

- 1) Gradually open the vent screw to vent gas from the transmitter pressure-detector section. (See figure 8.5)
- 2) When the transmitter is completely vented, close the vent screw.
- 3) Tighten the vent screw to a torque of 10 N·m.

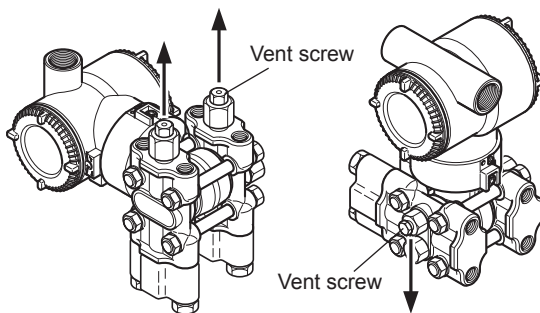

When you loosen the vent screw, the gas escapes in the direction of the arrow.

F0806.ai

Figure 8.5 Venting the Transmitter

9. Maintenance

9.1 Overview



WARNING

Since the accumulated process fluid may be toxic or otherwise harmful, take appropriate care to avoid contact with the body or inhalation of vapors when draining condensate or venting gas from the transmitter pressure-detector section and even after dismounting the instrument from the process line for maintenance.

Maintenance of the transmitter is easy due to its modular construction. This chapter describes the procedures for calibration, adjustment, and the disassembly and reassembly procedures required for component replacement.

Transmitters are precision instruments. Please carefully and thoroughly read the following sections for information on how to properly handle them while performing maintenance.



IMPORTANT

- As a rule, maintenance of this transmitter should be done in a shop that has all the necessary tools.
- The CPU assembly contains sensitive parts that can be damaged by static electricity. Take precautions such as using a grounded wrist strap when handling electronic parts or touching the board circuit patterns. Also be sure to place the removed CPU assembly into a bag with an antistatic coating.

9.2 Calibration Instruments Selection

Table 9.1 lists the instruments that can be used to calibrate a transmitter. When selecting an instrument, consider the required accuracy level. Exercise care when handling these instruments to ensure they maintain the specified accuracy.

9.3 Calibration

Use the procedure below to check instrument operation and accuracy during periodic maintenance or troubleshooting.

9.3.1 Pressure and Static Pressure.

- 1) Connect the instruments as shown in figure 9.1 and warm up the instruments for at least five minutes.



IMPORTANT

- Do not perform the calibration procedure until the transmitter is at room temperature.
 - To adjust the transmitter for highest accuracy, make adjustments with the power supply voltage and load resistance including leadwire resistances set close to the conditions under which the transmitter is installed.
 - If the measurement range 0% point is 0 kPa or shifted in the positive direction (suppressed zero), the reference pressure should be applied as shown in the figure. If the measurement range 0% point is shifted in the negative direction (elevated zero), the reference pressure should be applied using a vacuum pump.
- 2) Apply reference pressures of 0%, 25%, 50%, 75%, and 100% of the measurement range to the transmitter. Calculate the errors (differences between digital voltmeter readings and reference pressures) as the pressure is increased from 0% to 100% and is decreased from 100% to 0%, and confirm that the errors are within the required accuracy.

9.3.2 External Temperature (RTD)

Using a thermometer resistor as input, calibration of the temperature transmitter is carried out via a 3-core wire connection.

As defined the reference resistor value table of the thermometer resistor (RTD), obtain resistance values corresponding to 0, 25, 50, 75 or 100% of the span, and use the obtained resistance as the input value, then deliver it to the temperature transmitter by means of a variable resistor. Measure the resulting output signal with the voltmeter (digital multimeter) and check the output value relative to the input value.

If the output signal deviates from the given range of accuracy when a given input signal is delivered, adjust the output using the handheld terminal. For details of how to adjust the output, refer to the additional references, "HART communication type" IM 01C25R02-01E and the instruction manual for each terminal.

Table 9.1 Instruments Required for Calibration

Name	Yokogawa-recommended Instrument	Remarks
Power supply	Model SDBT or SDBS distributor	4 to 20 mA DC signal
Load resistor	Model 2792 standard resistor [250 Ω ±0.005%, 3 W]	
	Load adjustment resistor [100 Ω ±1%, 1 W]	
Voltmeter	Model 2501 A digital multimeter Accuracy (10V DC range): ±(0.002% of rdg + 1 dgt)	
Digital manometer	Model MT220 precision digital manometer 1) For 10 kPa class Accuracy: ±(0.015% of rdg + 0.015% of F.S.) for 0 to 10 kPa ±(0.2% of rdg + 0.1% of F.S.) for -10 to 0 kPa 2) For 130 kPa class Accuracy: ±0.02% of rdg for 25 to 130 kPa ±5 digits for 0 to 25 kPa ±(0.2% of rdg + 0.1% of F.S.) for -80 to 0 kPa 3) For 700 kPa class Accuracy: ±(0.02% of rdg + 3 digits) for 100 to 700 kPa ±5 digits for 0 to 100 kPa ±(0.2% of rdg + 0.1% of F.S.) for -80 to 0 kPa 4) For 3000 kPa class Accuracy: ±(0.02% of rdg + 10 digits) for 0 to 3000 kPa ±(0.2% of rdg + 0.1% of F.S.) for -80 to 0 kPa 5) For 130 kPa abs class Accuracy: ±(0.03% of rdg + 6 digits) for 0 to 130 kPa abs	Select a manometer having a pressure range close to that of the transmitter.
Pressure generator	Model 7674 pneumatic pressure standard for 200 kPa {2 kgf/cm ² }, 25 kPa {2500 mmH ₂ O} Accuracy: ±0.05% of F.S.	Requires air pressure supply.
	Dead weight gauge tester 25 kPa {2500 mmH ₂ O} Accuracy: ±0.03% of setting	Select the one having a pressure range close to that of the transmitter.
Pressure source	Model 6919 pressure regulator (pressure pump) Pressure range: 0 to 133 kPa {1000 mmHg}	Prepare the vacuum pump for negative pressure ranges.
Variable resistor	279301 type 6-dial variable resistor (accuracy: ±0.005%)	For calibration of thermometer resistor (RTD) input

Note: The above table contains the instruments capable of performing calibration to the 0.2% level. Since special maintenance and management procedures involving traceability of each instrument to higher-level standards are required for calibration to the 0.1% or higher level, there may be difficulties in calibration to this level in the field. For calibration to the 0.1% level, contact Yokogawa representatives from which the instrument was purchased or the nearest Yokogawa office.

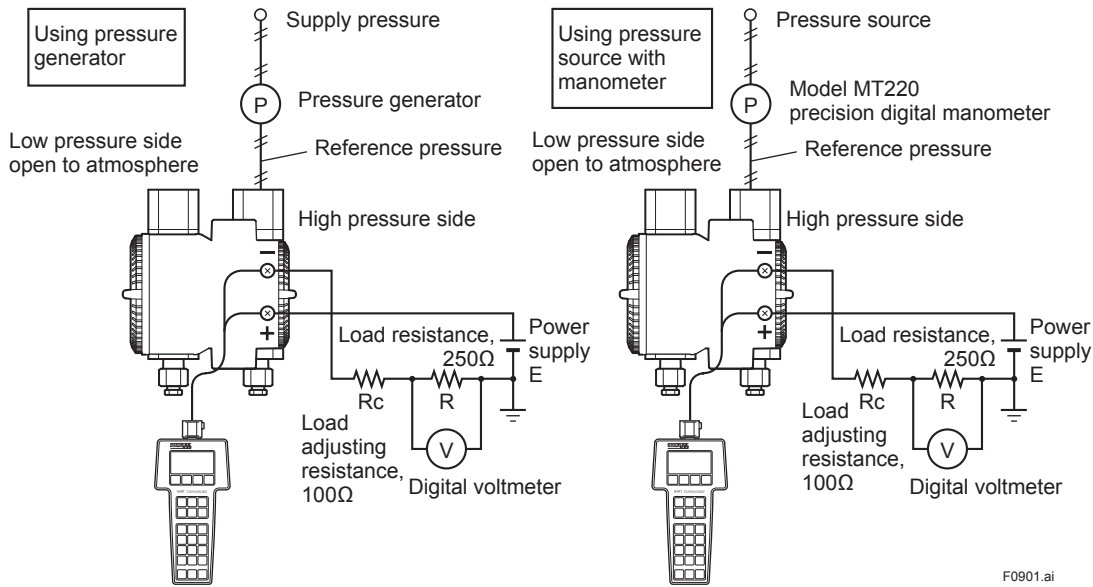

Figure 9.1 Instrument Connections for Differential Pressure (HART communication type)

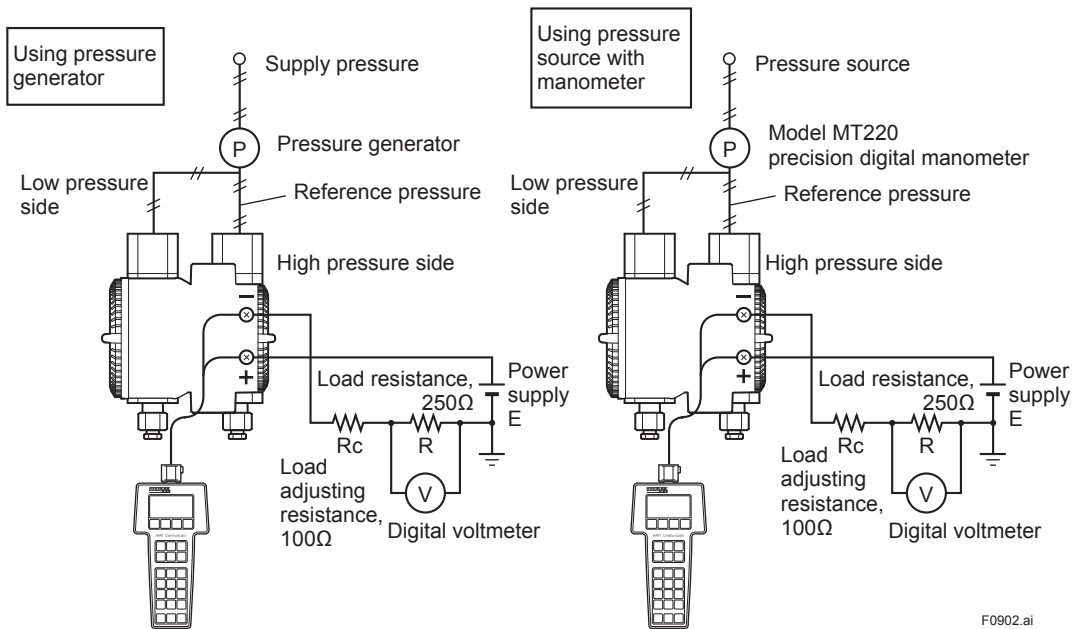

Figure 9.2 Instrument Connections for Static Pressure (HART communication type)



NOTE

Apply pressure to H side and L side evenly.

9.4 Disassembly and Reassembly

This section describes procedures for disassembly and reassembly for maintenance and component replacement.

Always turn OFF power and shut off and release pressures before disassembly. Use proper tools for all operations. Table 9.2 shows the tools required.

Table 9.2 Tools for Disassembly and Reassembly

Tool	Quantity	Remarks
Phillips screwdriver	1	JIS B4633, No. 2
Slotted screwdriver	1	
Allen wrenches	3	JIS B4648 One each, nominal 3, 4, 6 and 2.5 mm Allen wrenches ASME B18.3. One nominal 1/4 inch Allen wrenches (in case of 1/4NPT bug screen)
Wrench	1	Width across flats, 17 mm
Torque wrench	1	
Adjustable wrench	1	
Socket wrench	1	Width across flats, 16 mm
Socket driver	1	Width across flats, 5.5 mm
Tweezers	1	

CAUTION

Precautions for ATEX Flameproof Type Transmitters

- Flameproof type transmitters must be, as a rule, removed to a non-hazardous area for maintenance and be disassembled and reassembled to the original state.
- On the flameproof type transmitters the two covers are locked, each by an Allen head bolt (shrouding bolt). When a shrouding bolt is driven clockwise by an Allen wrench, it is going in and cover lock is released, and then the cover can be opened. When a cover is closed it should be locked by a shrouding bolt without fail. Tighten the shrouding bolt to a torque of 0.7 N·m.

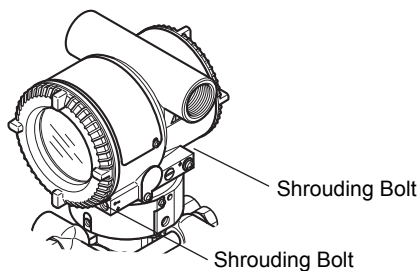

Figure 9.3 Shrouding Bolts

F0903.ai

9.4.1 Replacing the Integral Indicator

CAUTION

Cautions for Flameproof Type Transmitters

Users are prohibited by law from modifying the construction of a flameproof type transmitter. This would invalidate the agency approval for the use of the transmitter in a rated area. It follows that the user is prohibited from using a flameproof type transmitter with its integral indicator removed, or from adding an integral indicator to a transmitter. If such modification is absolutely required, contact Yokogawa.

This subsection describes the procedure for replacing an integral indicator. (See figure 9.4)

■ Removing the Integral Indicator

- 1) Remove the cover.
- 2) While supporting the integral indicator with one hand, loosen its two mounting screws.
- 3) Dismount the LCD board assembly from the CPU assembly.
When doing this, carefully pull the LCD board assembly straight forward so as not to damage the connector pins between it and the CPU assembly.

■ Attaching the Integral Indicator

- 1) Align both the LCD board assembly and CPU assembly connectors and engage them.
- 2) Insert and tighten the two mounting screws.
- 3) Replace the cover.

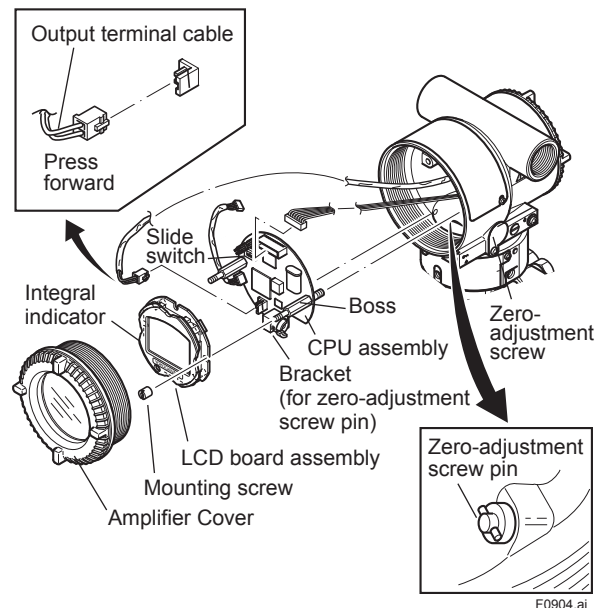

Figure 9.4 Removing and Attaching LCD Board Assembly and CPU Assembly (HART Communication Type)

F0904.ai

9.4.2 Replacing the CPU Board Assembly

This subsection describes the procedure for replacing the CPU assembly. (See figure 9.4)

■ Removing the CPU Assembly

- 1) Remove the cover. If an integral indicator is mounted, refer to subsection 9.4 and remove the indicator.
- 2) Turn the zero-adjustment screw to the position (where the screw head slot is horizontal) as shown in figure 9.4.
- 3) Disconnect the output terminal cable (cable with brown connector at the end) and RTD input terminal cable (cable with blue connector at the end). When doing this, lightly press the side of the CPU assembly connector and pull the cable connector to disengage.
- 4) Use a socket driver (width across flats, 5.5mm) to loosen the two bosses.
- 5) Carefully pull the CPU assembly straight forward to remove it.
- 6) Disconnect the flat cable (cable with white connector at the end) that connects the CPU assembly and the capsule.



NOTE

Be careful not to apply excessive force to the CPU assembly when removing it.

■ Mounting the CPU Assembly

- 1) Connect the flat cable (with white connector) between the CPU assembly and the capsule.
- 2) Connect the output terminal cable (with brown connector) and RTD input terminal cable (with blue connector).



NOTE

Make certain that the cables do not get pinched between the case and the edge of the CPU assembly.

- 3) Align and engage the zero-adjustment screw pin with the groove on the bracket on the CPU assembly. Then insert the CPU board assembly straight onto the post in the amplifier case.

- 4) Tighten the two bosses. If the transmitter is equipped with an integral indicator, refer to subsection 9.4.1 to mount the indicator.



NOTE

Confirm that the zero-adjustment screw pin is placed properly in the groove on the bracket prior to tightening the two bosses. If it is not, the zero-adjustment mechanism will be damaged.

- 5) Replace the cover.

9.4.3 Cleaning and Replacing the Capsule Assembly

This subsection describes the procedures for cleaning and replacing the capsule assembly. (See figure 9.5.)



CAUTION

Cautions for Flameproof Type Transmitters

Users are prohibited by law from modifying the construction of a flameproof type transmitter. If you wish to replace the capsule assembly with one of a different measurement range, contact Yokogawa.

The user is permitted, however, to replace a capsule assembly with another of the same measurement range. When doing so, be sure to observe the following.

- The replacement capsule assembly must have the same part number as the one being replaced.
- The section connecting the transmitter and capsule assembly is a critical element in preservation of flameproof performance, and must be checked to verify that it is free of dents, scratches, and other defects.
- After completing maintenance, be sure to securely tighten the setscrews that fasten the transmitter section and pressure-detector section together.

■ **Removing the Capsule Assembly**



IMPORTANT

Exercise care as follows when cleaning the capsule assembly.

- Handle the capsule assembly with care, and be especially careful not to damage or distort the diaphragms that contact the process fluid.
- Do not use a chlorinated or acidic solution for cleaning.
- Rinse thoroughly with clean water after cleaning.

- 1) Remove the CPU assembly as shown in subsection 9.4.2.
- 2) Remove the two setscrews that connect the transmitter section and pressure-detector section.
- 3) Remove the hexagon-head screw and the stopper.
- 4) Separate the transmitter section and pressure-detector section.
- 5) Remove the nuts from the four flange bolts.
- 6) While supporting the capsule assembly with one hand, remove the cover flange.
- 7) Remove the capsule assembly.
- 8) Clean the capsule assembly or replace with a new one.

■ **Reassembling the Capsule Assembly**

- 1) Insert the capsule assembly between the flange bolts, paying close attention to the relative positions of the H (high pressure side) and L (low pressure side) marks on the capsule assembly.
Replace the two capsule gaskets with new gaskets.
- 2) Install the cover flange on the high pressure side, and use a torque wrench to tighten the four nuts uniformly to a torque shown below.

Model	EJX910A
Torque(N·m) {kgf·m}	17 {1.7}

Model	EJX930A	
Bolts & nuts material code	G, C	J
Torque(N·m) {kgf·m}	90 {9.2}	110 {11.2}

- 3) After the pressure-detector section has been reassembled, a leak test must be performed to verify that there are no pressure leaks.
- 4) Reattach the transmitter section to the pressure-detector section.
Reattach the stopper with the hexagon-head screw.
- 5) Tighten the two setscrews. (Tighten the screws to a torque of 1.5 N·m)
- 6) Install the CPU assembly according to subsection 9.4.2.
- 7) After completing reassembly, adjust the zero point and recheck the parameters.

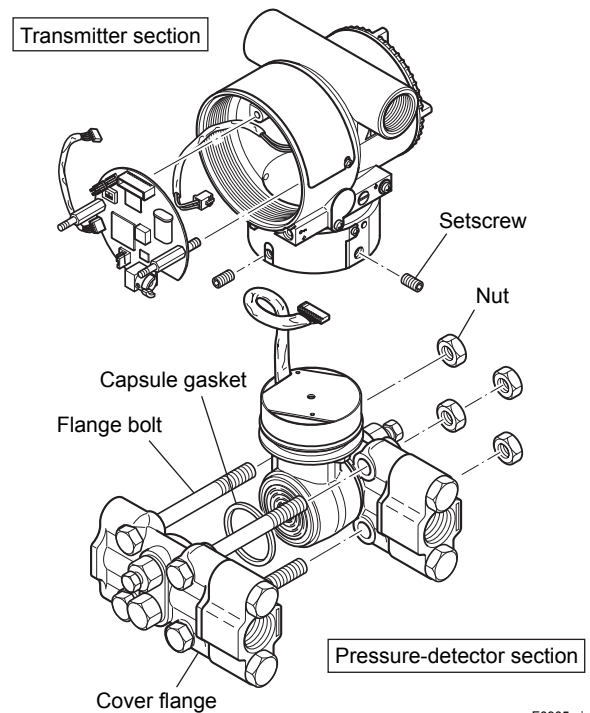

Figure 9.5 Removing and Mounting the Pressure-detector Section



IMPORTANT

If you remove the vent/drain plugs when disassembling EJX930A transmitter, install the plugs again before reassembling the cover flanges with the capsule assembly.

9.4.4 Replacing the Process Connector Gaskets

This subsection describes process connector gasket replacement. (See figure 9.6)

- (a) Loosen the two bolts, and remove the process connectors.
- (b) Replace the process connector gaskets.
- (c) Remount the process connectors. Tighten the bolts securely and uniformly to a torque of 39 to 49 N·m {4 to 5 kgf·m}, and verify that there are no pressure leaks.

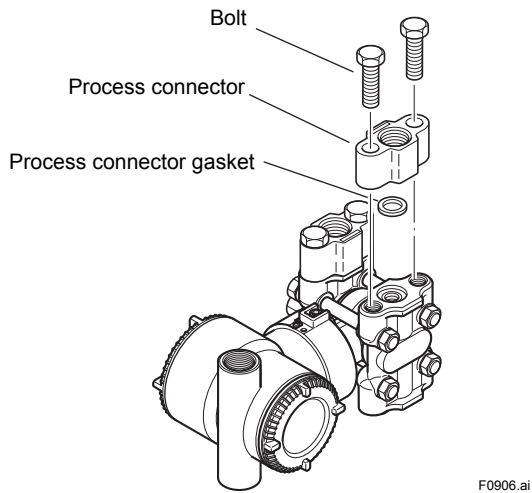

Figure 9.6 Removing and Mounting the Process Connector

9.4.5 Cleaning/replacing the bug screen (Option Code /BS)

The procedures for cleaning and replacing the bug screen are described below. (See figure 9.7)

- (1) Loosen the bug screen (one screw) with a Allen wrench (JIS B4648 Nominal 6 or ASME B18.3 Nominal 1/4 *1 *2).
- (2) Clean or replace the bug screen. (Tighten with a torque of approximately 3 N·m)

- *1: For EJX910A with the process connection code 0, 1 or 2, use a allen wrench (JIS B4648 No. 6).
- *2: For EJX910A with the process connection code 3, 4, or 5, use a allen wrench (ASME B18.3 Nominal 1/4).

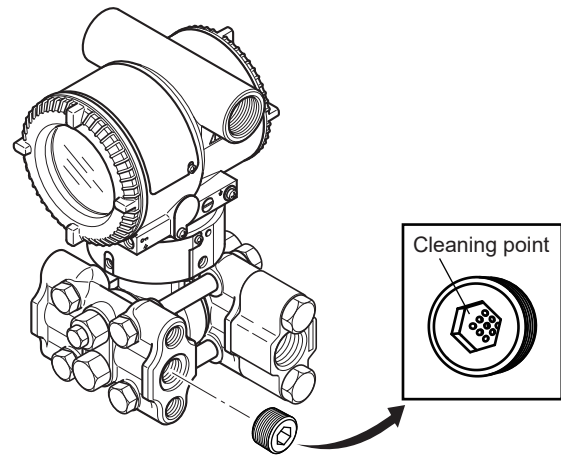

Figure 9.7 Remove/Install a bug screen



IMPORTANT

Keep the following in mind when cleaning the bug screen:

- Do not use chlorine or acidic solutions for cleaning.
- After cleaning, rinse with clean water and dry until the water is completely drained.

9.5 Troubleshooting

If any abnormality appears in the measured values, use the troubleshooting flow chart below to isolate and remedy the problem. Since some problems have complex causes, these flow charts may not identify all. If you have difficulty isolating or correcting a problem, contact Yokogawa service personnel.

9.5.1 Basic Troubleshooting

First determine whether the process variable is actually abnormal or a problem exists in the measurement system.

If the problem is in the measurement system, isolate the problem and decide what corrective action to take.

This transmitter is equipped with a self-diagnostic function which will be useful in troubleshooting, and the transmitter equipped with an integral indicator will show an alarm code as a result of self-diagnosis.

See subsection 9.5.3 for the list of alarms. See also each communication manual.

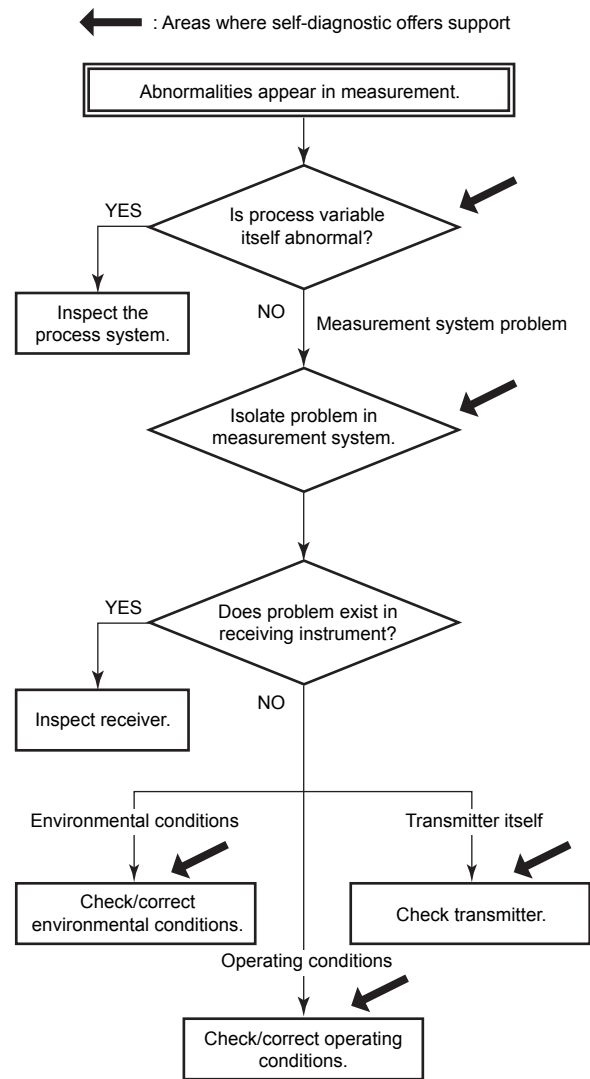

F0907.ai

Figure 9.8 Basic Flow and Self-Diagnostics

9.5.2 Troubleshooting Flowcharts

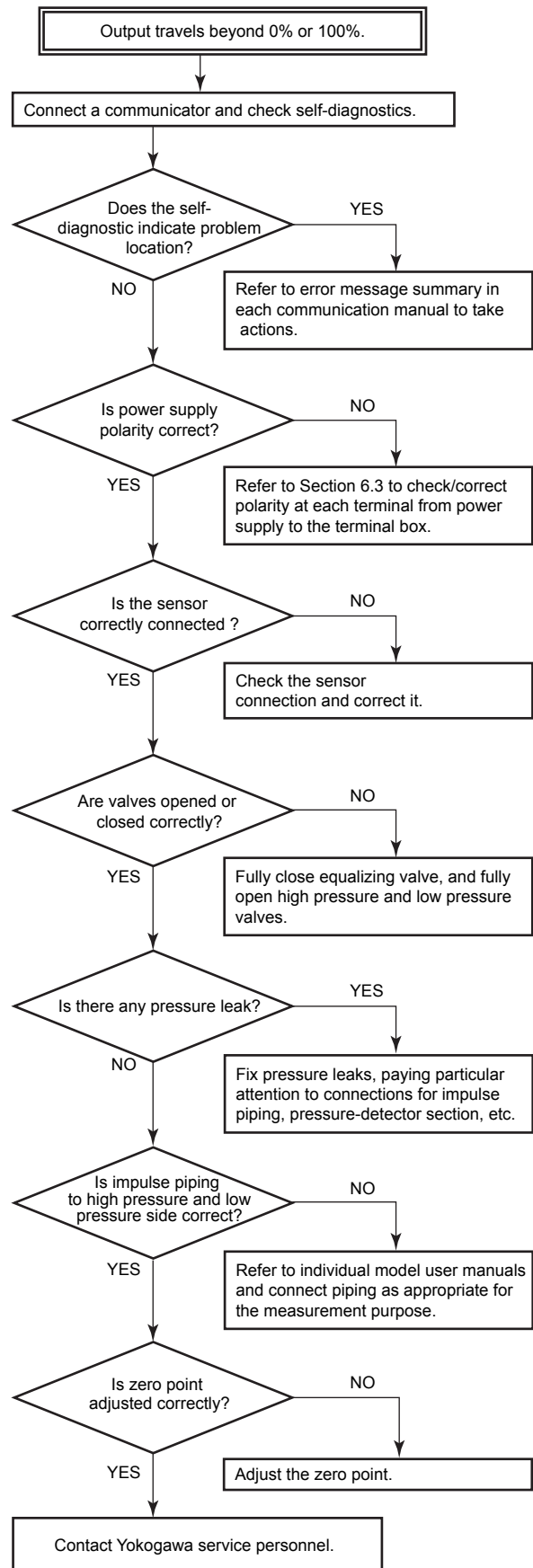
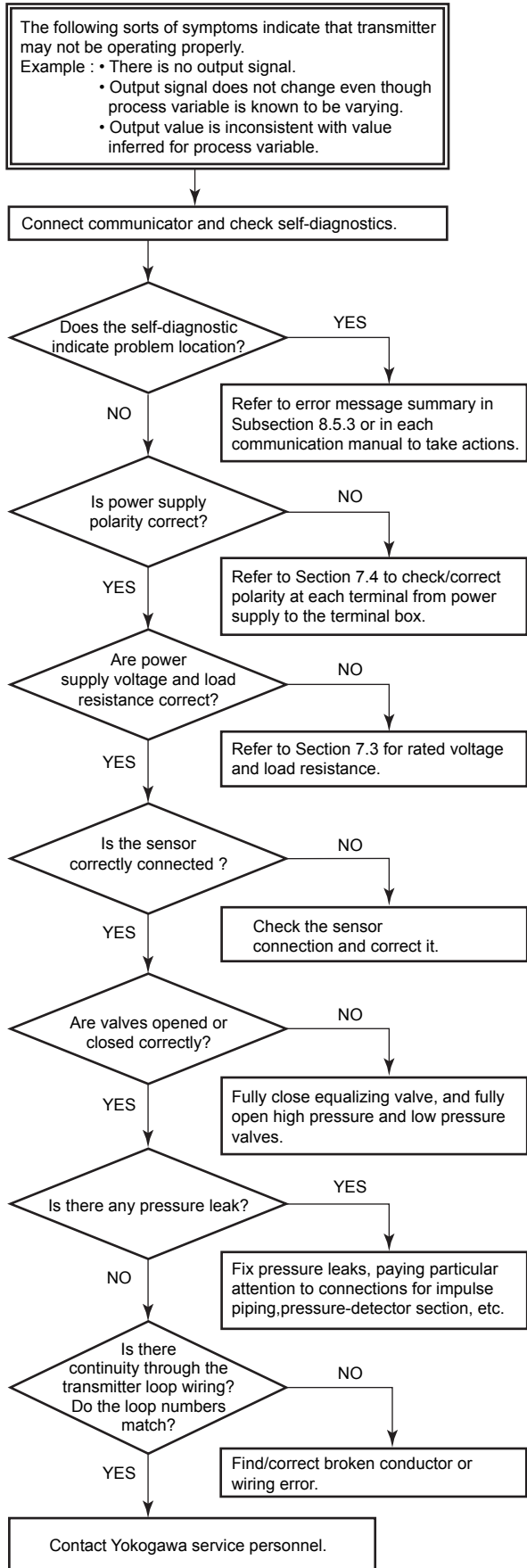

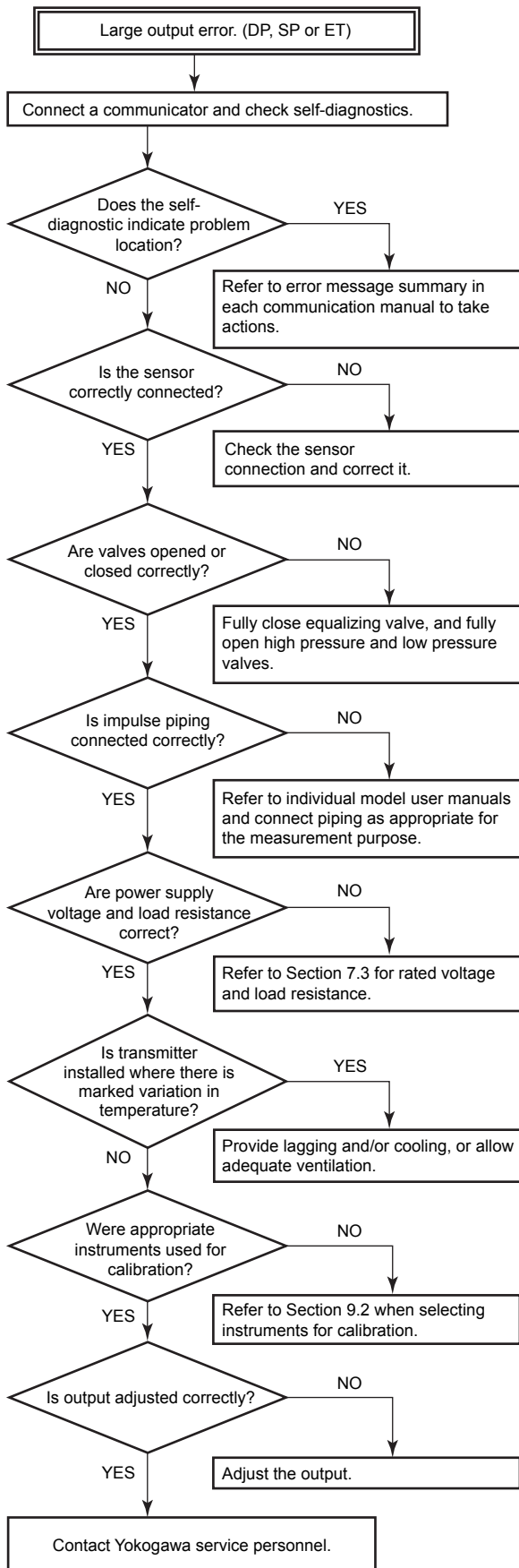

F0910.ai

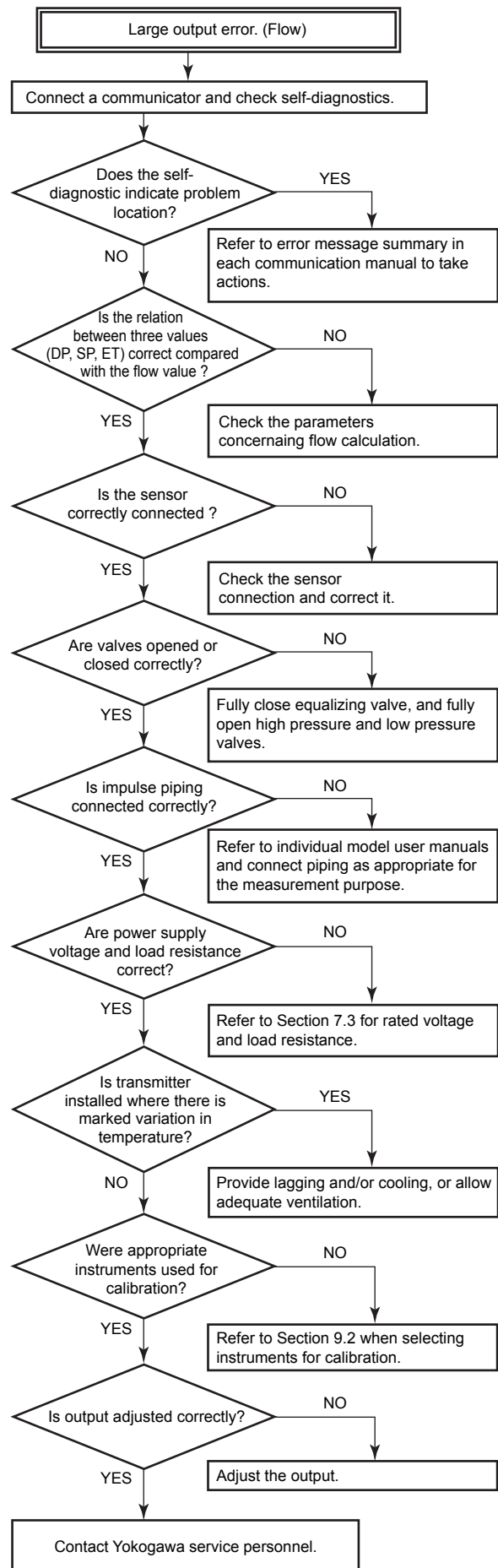

F0911.ai

9.5.3 Alarms and Countermeasures

Table 9.3 Alarm Message Summary (HART communication type)

Integral indicator	HART communicator display	Cause	4-20mA Output operation during error	Countermeasure	Status group	
AL. 01 CAP.ERR	P sensor error	Sensor problem.	Outputs the signal (High or Low) set with burnout direction switch. [status output: undefined]	Replace capsule if the error recurs after the transmitter is restarted.	1	
	CT sensor error	Capsule temperature sensor problem.		Replace capsule.		
	Cap EEPROM error	Capsule EEPROM problem.				
AL. 02 AMP.ERR	AT sensor error	Amplifier temperature sensor problem.			Replace amplifier.	2
	Amp EEPROM error	Amplifier EEPROM problem.				
	CPU board error	Amplifier problem.				
	AD Converter error	A/D Converter problem.				
AL. 03 ET.ERR	ET sensor error	External temperature sensor disconnection.		Check external temperature sensor.	4	
—	No device ID	No device ID is found.	Continues to operate and output.		2	
AL. 10 PRESS	P outside limit	Input is outside measurement range limit of capsule.	When PV is Pres Output AO upper limit or AO Lower limit.	Check input or replace capsule when necessary.	3	
AL. 11 ST. PRSS	SP outside limit	Static pressure exceeds limit.	When PV is SP Output AO upper limit or AO Lower limit.			
AL. 12 CAP.TMP	CT outside limit	Capsule temperature is outside range (–50 to 130°C).	Continues to operate and output.			
AL. 13 AMP.TMP	AT outside limit	Amplifier temperature is outside range (–50 to 95°C).	When PV is ET Output AO upper limit or AO Lower limit.	Use heat insulation or make lagging to keep temperature within range.	3	
AL. 14 EXT. TMP	ET outside limit	External temperature is outside range.				
AL. 15 EXT. TMP	OHM outside limit	External temperature sensor resistance is out specification.				
AL. 16 PLS	PLS outside limit	Pulse output is out specification.	Continues to operate and output.	Check settings and change them.		
AL. 30 PRS.RNG	P over range	Differential pressure exceeds specified range.	When PV is Pres. Outputs the signal (High or Low) set with burnout direction switch. Low:–1.25%, High:110%	Check input and range setting, and change them as needed.	4	
AL. 31 SP. RNG	SP over range	Static pressure exceeds specified range.	When PV is SP Outputs the signal (High or Low) set with burnout direction switch. Low:–1.25%, High:110%			
AL. 32 F. RNG	F over range	Flow exceeds specified range.	When PV is Flow Outputs the signal (High or Low) set with burnout direction switch. Low:–1.25%, High:110%			
AL. 33 ET. RNG	ET over range	External temperature exceeds specified range.	When PV is ET Outputs the signal (High or Low) set with burnout direction switch. Low:–1.25%, High:110%			

Integral indicator	HART communicator display	Cause	4-20mA Output operation during error	Countermeasure	Status group	
AL. 41 F.HI	F high alarm	Input flow exceeds specified threshold.	Continues to operate and output.	Check input.	5	
AL. 42 F.LO	F low alarm					
AL. 35 P.HI	P high alarm	Input pressure exceeds specified threshold.				
AL. 36 P.LO	P low alarm					
AL. 37 SP.HI	SP high alarm	Input static pressure exceeds specified threshold.				
AL. 38 SP.LO	SP low alarm					
AL. 43 ET.HI	ET high alarm	Input external temperature exceeds specified threshold.				
AL. 44 ET.LO	ET low alarm					
AL. 50 P. LRV	Illegal P LRV	Specified value is outside of setting range.	Holds at the output value that existed immediately before the error occurred.	Check settings and change them as needed.	6	
AL. 51 P. URV	Illegal P URV					
AL. 52 P. SPN	Illegal P SPAN					
AL. 53 P. ADJ	P SPAN trim err		Continues to operate and output.	Adjust settings and change them as needed.		
	P ZERO trim err					
AL. 54 SP. RNG	Illegal SP LRV		Holds at the output value that existed immediately before the error occurred.	Check settings and change them as needed.		
	Illegal SP URV					
	Illegal SP SPAN					
AL. 55 SP. ADJ	SP SPAN trim err		Continues to operate and output.	Adjust settings and change them as needed.		7
	SP ZERO trim err					
AL. 56 ET. RNG	Illegal ET SPAN	Holds at the output value that existed immediately before the error occurred.	Check settings and change them as needed.	8		
AL. 57 ET. ADJ	ET SPAN trim err	Continues to operate and output.	Adjust settings and change them as needed.	7		
	ET ZERO trim err					
AL. 58 FL. ADJ	F set outside Range	Specified value is outside of setting range.	Holds at the output value that existed immediately before the error occurred.	Check settings and change them as needed.	8	
AL. 59 PLS.ADJ	PLS set err	Specified value is outside of setting pulse output.	Normal calculation.		7	
AL. 79 OV. DISP	(None)	Displayed value exceeds limit.	Continues to operate and output.		—	

Integral indicator	HART communicator display	Cause	4-20mA Output operation during error	Countermeasure	Status group
AL.87 FLG. HI	FT high alarm	Flange temperature exceeds a preset upper limit.	It depends on the Diag Out Option setting.	Check the heater failure.	9
AL.87 FLG. LO	FT low alarm	Flange temperature is below a preset lower limit.	Off: Continue to operate and output. Burnout: Outputs AO upper limit or AO lower limit. Fall back: Outputs Diag Out Fixed Val.	Check the capsule temp. and Amplifier temp. Adjust Flg Temp Coef.	
AL.88 INVR.DP	Invalid Ref DP	Differential pressure/ pressure fluctuation does not reach the reference level required to blockage detection so that no blockage detection is carried out.	Continue to operate and output.	Check process condition.	
AL.88 INVR.SL	Invalid Ref SPL	Low-pressure-side fluctuation does not reach the reference fluctuation level required to blockage detection.			
AL.88 INVR.SH	Invalid Ref SPH	High-pressure-side fluctuation does not reach the reference fluctuation level required to blockage detection.			
AL.88 INVR.F	Invalid Ref F	BlkF can not be used for blockage detection for some reasons.			
AL.89 ILBD.OV	ILBD over range	Appointed the diagnosis range outside.		Check process condition.	
AL.89 B BLK	B Blocking	B Blocking (both-side blockage) is detected.	It depends on the Diag Out Option setting. Off: Continue to operate and output. Burnout: Outputs AO upper limit or AO lower limit. Fall back: Outputs Diag Out Fixed Val.	Check process condition.	10
AL.89 H BLK	H Side Blocking	High-pressure-side blockage is detected.			
AL.89 L BLK	L Side Blocking	Low-pressure-side blockage is detected.			
AL.89 H LRG	Large Fluct H	Pressure fluctuation amplitude of high-pressure side is large.			
AL.89 L LRG	Large Fluct L	Pressure fluctuation amplitude of low-pressure side is large.			
AL.89 A BLK	A Blocking	A Blocking (single-side blockage) is detected.			
AL. 90 SIM	Simulate Mode	Under Simulation Mode.	Simulate input output.	Check Simulation Mode.	5
—	ET Fixed Mode	Under Temperature Fix Mode. PV is ET	Temp. Output Fix at 4mA.	Leave from Temperature Fix Mode.	7

10. General Specifications

Please refer to the following General Specifications list for the specifications, model, suffix and option codes, and external dimensions of each product.

The General Specifications can be downloaded from the website of Yokogawa.

Website address: <https://www.yokogawa.com/solutions/products-platforms/field-instruments/>

■ General Specifications List

Model	Document Title	Document No.
EJX110A	Differential Pressure Transmitter	GS 01C25B01-01EN
EJX120A	Differential Pressure Transmitter	GS 01C25B03-01EN
EJX130A	Differential Pressure Transmitter	GS 01C25B04-01EN
EJX210A	Flange Mounted Differential Pressure Transmitter	GS 01C25C01-01EN
EJX310A	Absolute Pressure Transmitter	GS 01C25D01-01EN
EJX430A	Gauge Pressure Transmitter	GS 01C25E01-01EN
EJX440A	Gauge Pressure Transmitter	GS 01C25E02-01EN
EJX510A, EJX530A	Absolute and Gauge Pressure Transmitters	GS 01C25F01-01EN
EJX610A, EJX630A	Absolute and Gauge Pressure Transmitters	GS 01C25F05-01EN
EJX118A	Diaphragm Sealed Differential Pressure Transmitter	GS 01C25H01-01EN
EJX118A	Diaphragm Sealed Differential Pressure Transmitter (Inner Diaphragm type)	GS 01C25H01-11EN
EJX438A	Diaphragm Sealed Gauge Pressure Transmitter	GS 01C25J03-01EN
EJX438A	Diaphragm Sealed Gauge Pressure Transmitter (Inner Diaphragm type)	GS 01C25J03-11EN
EJX115A	Low Flow Transmitter	GS 01C25K01-01EN
EJX910A	Multivariable Transmitter	GS 01C25R01-01EN
EJX930A	Multivariable Transmitter	GS 01C25R04-01EN
EJXC50A, EJXC40A, EJAC50E, C20FE, C20FW, C10FR, EJXC80A, EJAC80E, C81FA, C82FA, C81FD, C82FD, C30SW, C30SE, C80FW, C80FE, EJXC81A, EJAC81E, C70SE, C70SW	Diaphragm Seal System	GS 01C25W01-01EN
EJXC40A	Digital Remote Sensor	GS 01C25W05-01EN
EJX110A, EJX130A	Differential Pressure Transmitter High Damping Capsule (Option Code: /HD)	GS 01C25V01-01EN
EJX110A	Differential Pressure Transmitters High Damping Capsule (General) (Option Code: /HD2)	GS 01C25V02-01EN
EJX-A, EJA-E	Explosion Protected Type and Marine Certificate Type	GS 01C25A20-01EN
EJA110E	Differential Pressure Transmitter	GS 01C31B01-01EN
EJA120E	Differential Pressure Transmitter	GS 01C31B03-01EN
EJA130E	Differential Pressure Transmitter	GS 01C31B04-01EN
EJA210E	Flange Mounted Differential Pressure Transmitter	GS 01C31C01-01EN
EJA310E	Absolute Pressure Transmitter	GS 01C31D01-01EN
EJA430E	Gauge Pressure Transmitter	GS 01C31E01-01EN
EJA440E	Gauge Pressure Transmitter	GS 01C31E02-01EN
EJA510E, EJA530E	Absolute Pressure Transmitter and Gauge Pressure Transmitter	GS 01C31F01-01EN
EJA118E	Diaphragm Sealed Differential Pressure Transmitter	GS 01C31H01-01EN
EJA118E	Diaphragm Sealed Differential Pressure Transmitter (Inner Diaphragm type)	GS 01C31H01-11EN
EJA438E	Diaphragm Sealed Gauge Pressure Transmitter	GS 01C31J03-01EN
EJA438E	Diaphragm Sealed Gauge Pressure Transmitter (Inner Diaphragm type)	GS 01C31J03-11EN
EJA115E	Low Flow Transmitter	GS 01C31K01-01EN
EJAC60E, EJA560E	Hygienic Adapter System (Fluidless Type) Hygienic Gauge Pressure Transmitter (Fluidless Type)	GS 01C31Y01-01EN
EJA110E, EJA130E	Differential Pressure Transmitter High Damping Capsule (Option Code: /HD)	GS 01C31V01-01EN
EJA110E	Differential Pressure Transmitters High Damping Capsule (General) (Option Code: /HD2)	GS 01C31V02-01EN

If you cannot find it on our website, please contact YOKOGAWA office.

Revision Information

- Title : EJX910A and EJX930A
Multivariable Transmitters
- Manual No. : IM 01C25R01-01E

Edition	Date	Page	Revised Item
1st	May 2005	—	New publication
2nd	June 2006	— 1-1 2-7 3-3 3-5 3-6 7-1 7-3 10-1 10-3 10-6 10-8 and 10-9 10-11	Add information for FOUNDATION fieldbus protocol type. Add comments for fieldbus in 'NOTE' 2.5.2 Correct errors in the formula. Correct errors in Table 2.8 3.9 Add WARNING for fieldbus and external temperature input cable. 3.9.3 Add CENELEC ATEX intrinsically safe type. 3.10 Correct errors. 3.11 Revise information for PED. 3.12 Section added. 7.1 Add note for fieldbus type in 'IMPORTANT' notice. 7.5.1 Add (2)Intrinsically Safe Type. 10.1 Add information and note for fieldbus type. Add information of L capsule. Delete information related to the auto compensation function. 10.2 Add code for FOUNDATION fieldbus type, L capsule, bottom process connection and a bracket. 10.3 Add /KS2, /T12 and /PE3. 10.4 Add dimensions for bottom process connection. Add note for fieldbus type.
3rd	Feb. 2008	— General 2-4 to 2-7 3-3 to 3-7 3-7 10-2 and 10-4 10-5 10-7 and 10-8 10-10 and 10-11	Change of the style code. Change the figure of amplifier housing. 2 Remove FSA210 and add FSA120. 3.9 Add applicable standard and certificate number for each approval. 3.9.4 Add IECEx flameproof type (/SF2). 10.1 Remove FSA210 and add FSA120. 10.2 Add new suffix codes for 316 SST blind plugs and brackets. 10.3 Add /KS25 and /SF2. 10.4 Revise external dimensions.
4th	Aug. 2008	3-8 10-7 10-8	3.10 Add caution for EMC. 10.3 Add /FS15. 10.3 Add the description of Process Sealing Certification to /CF1.
5th	Mar. 2009	— 3-6	Add model EJX930A. 3.9.3 Add /KU2.
6th	Aug. 2009	10-5 to 10-7 10-8 to 10-10 10-12 to 10-14	10.2 Revise material statement. 10.3 Add optional code /KU21 and /A1. 10.4 Correct the dimension of the cable gland with 1/2 NPT connections.
7th	Apr. 2010	2-5 3-1 3-4 to 3-9 7-4 to 7-6 9-11 10-4 10-8 to 10-9 10-10 10-12 to 10-14	2.5 Add Unit for Device Revision 2. 3.3 Add limitation of ambient temperature for /HE. 3.9 Add limitation of ambient temperature for /HE. 7.6.1 Change the figure of cable gland. 9.5.3 Add ILBD alarms. 10.1 Add material for cover O-rings. 10.3 Add limitation of ambient temperature for /HE. 10.3 Add /HE and /DG6. 10.4 Correct the dimension of the cable gland with M20 connections.

Edition	Date	Page	Revised Item
8th	Aug. 2011	1-1, 2-3 and 10-4 2-4 3-9 7-8 10-1 to 10-4 10-5, 10-6, 10-9 and 10-11	1, 2.3, 2.4, 10.1 Change FSA120 product name. 2.4.1 Change FSA120 product name. 2.5 Correct the Kfactor equation of Basic Mode. 3.9.3 Update explanation of Name Plate. 7.7 Add the note when using analog and pulse output simultaneously. 10.1 Corresponds to output signal code J (HART 5/HART 7 protocol). Add analog output status at process abnormality (Option code /DG6). Change FSA120 product name. 10.2, 10.3 Corresponds to output signal code J (HART 5/HART 7 protocol).
9th	Mar. 2012	3-3 7-5 to 7-6 10-5 10-6 to 10-7 10-9 to 10-10	3.9 Add note for blind plugs. 7.6.1, 7.6.3 Add the procedure for electrical connection code F (G1/2 female). 10.1 Change the Specification of "Degree of Protection" and "Name plate and tag". 10.2 Add the electrical connection code F, 5 and A. Delete the mounting bracket code G. 10.3 Update the description. Add the Explosion Protected Optional Specification for EJJ930A (FS15, KS2, CF1, SF2).
10th	Aug. 2012	3-1 3-5 to 3-9 10-9 to 10-10	3.1 Change the name plate picture. 3.9.3 Revise the contents of ATEX flameproof approval and type n declaration. 10.3 Replace /KF21 and /KU21 with /KF22 and /KU22.
11th	June 2013	— 9-3 10-10 10-13 to 10-15	EJXMVTool → FlowNavigator 9.3.2 Error correction. 10.3 Change ATEX intrinsically safe to /KS26 from /KS25. 10.4 Add note for shrouding bolt.
12th	Nov. 2013	—	Add information for Modbus protocol type.
13th	June 2014	1-2 3-11 7-1 to 7-10 7-2 10-14 to 10-16 10-17	1. Add note for symbols. 3.12 Update safety requirement standard. 7. Revise drawings and symbols for terminal. 7.4.1 Add note for power supply. 10.4 Revise a part of dimension for horizontal piping use. Change terminal drawing.
14th	Oct. 2014	3-4 to 3.6 3-10 10-5 10-11	3.9.1 to 3.9.3 Add /V1F. Add "RS485. 3.9.4 Add EPL code. Revise applicable standard. Add note for electro static charge. Add electrical connection. Add standard for PROFIBUS. 10.1 Add EMI specification. 10.3 Revise the description for SF2. Add /V1F.
15th	July 2015	1-2 1-3 3-1 3-4 to 3-6, 3-9 3-5 3-8 3-8 3-10 3-11 10-5 10-7, 10-8 10-9 10-10, 10-11	Add trademark statement. 1.1 Add (g) and (h). 3.1 Replace Figure 3.2. Delete /V1F. 3.9.2 Add "No.61010-2-030." 3.9.3 Delete c. 3.9.3 (6) Replace nameplate. Delete type n tag plate. 3.10 Add EN 61326-2-5. 3.12 Add C22.2 standards. 10.1 Add information for EMC conformity standards. 10.2 Add material for mounting bracket code D and K. 10.2 Delete #. 10.3 Delete KU22 and V1F. Delete *3 for SF2.

Edition	Date	Page	Revised Item
16th	Jan. 2018	3-1,5-2, 6-2, 10-14, 10-16 1-1 to 1-3 2-4, 2-6, 2-7 3-6 to 3-7 3-9 3-10 10-5 10-11	Update L bracket. Reflect Manual Changes. (Regarding this manual and 1.1(i). Add [In case of orifice]. Update ATEX flameproof. Delete ATEX i.s. Update PED. (97/23/EC → 2014/68/EU) Add "3.13 EU RoHS Directive." Add EU RoHS Directive. Add local certificate option codes.
17th	Feb. 2020	1-1 1-5 3-4 3-9 5-4 7-4 10-10 to 10-12	1. Add instructions and items in NOTE and the diagram. Delete 1.3 ATEX Documentation. 3.9.1 a Update Applicable standard. 3.10 Move descriptions for testing from 10.1. 5.5 Modify the descriptions. Add WARNING. 7.6.1 Add CAUTION for cable glands. 10.3 Add note about codes. Delete details from approval codes. Add NF21, PF23 and UN.
18th	July 2021	3-6 3-7 3-7 3-10 10-1	3.9.3 a Update applicable standard. Add Note 3 and 6. Update the description for Note 4 and 7 3.9.3 (2) Delete screw size and marking. Delete WARNING. 3.9.3 (3) Update tag plates. 3.13 Change EU RoHS Directive. 10. Delete the description for general specifications and add the General Specifications list.
19th	Oct. 2022	1-3 2-3, 2-4, 2-6 3-1 3-8 3-11 5-2 6-1 7-6 9-7	1.1 (h) Change description for Authorized Representative in EEA and the importer into the EU/EEA market. 2.4, 2.4.1, 2.5,1 Add description for DevRev12 new functon. 3 Add description for option /BS12 and position adjustable bracket. 3.9.4 Add description for option /SF22. 3.13 Add national production site for EU RoHS. 5.2 Add the way of installation for positon adjustable bracket. 6.1.1 Add description for oprion /BS. 7.6 Change the way of RTD connection. 9.4.5 Add description for option /BS.