

Quick Start Guide

Introduction

The iVu TG Gen2 Image Sensor is used to monitor labels, parts, and packaging for type, size, orientation, shape, and location. The sensor has an integrated or remote color touch screen display making installation, setup and configuration easy without requiring a PC.

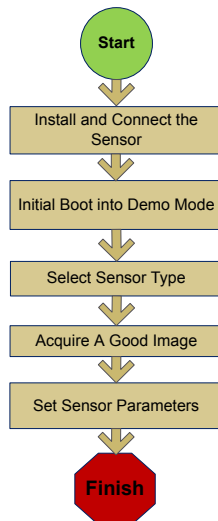

Quick Start Overview

This guide is designed to help you set up and install the iVu TG. It provides an overview of the sensor and illustrates how to set up the sensor to inspect a label, part, or packaging. The flow chart to the left provides an overview of the process.

Use of this document assumes familiarity with pertinent industry standards and practices.

For complete information on programming, performance, troubleshooting, dimensions, and accessories, please refer to the documentation listed below. This documentation is available on the Product CD or at www.bannerengineering.com. Search for the part number to view the documentation.

- *iVu TG Gen2 with Integrated Display* (datasheet; P/N 180757)
- *iVu TG Gen2 for use with Remote Display* (datasheet; P/N 180758)
- *iVu TG Gen2 Instruction Manual* (P/N 179043)

In addition, the sensor includes integrated Help.



WARNING: Not To Be Used for Personnel Protection

Never use this device as a sensing device for personnel protection. Doing so could lead to serious injury or death. This device does not include the self-checking redundant circuitry necessary to allow its use in personnel safety applications. A sensor failure or malfunction can cause either an energized or de-energized sensor output condition.



CAUTION: Electrostatic Discharge

Avoid the damage that electrostatic discharge (ESD) can cause to the Sensor.

Always use a proven method for preventing electrostatic discharge when installing a lens or attaching a cable.

Installing and Connecting the Sensor

The iVu TG sensor requires a bracket for mounting. Three brackets are available from Banner. The brackets allow the sensor to be mounted either perpendicular to the part or at an adjustable angle.

Thread three M4 x 4mm screws through the bracket into the mounting holes in the bottom of the sensor. Tighten all three screws.



Table 1: iVu Brackets



Cable Connections for iVu TG with Integrated Display

The cable connections on the iVu TG sensor are shown below, and the power I/O connections (B) are defined in [Table 2](#) on page 2.



- A USB Connector
- B Power I/O Connector



NOTE: Micro video lens model shown. C-Mount model connections are identical.

Table 2: Power I/O Connections

Pin #	Wire Color	Description	Direction
1	White	Output 1	Output
2	Brown	10-30V dc	Input
3	Green	Output 2	Output
4	Yellow	Strobe Out (5V dc only)	Output
5	Gray	Remote Teach	Input
6	Pink	External Trigger	Input
7	Blue	Common (Signal Ground)	Input
8	Red	Ready	Output

Cable Connections for the iVu TG with a Remote Display

The cable connections on the iVu TG sensor are shown below, and power I/O connections (B) are defined in [Table 3](#) on page 2.

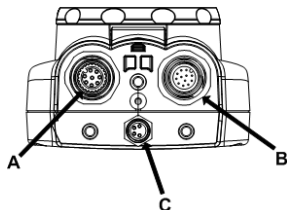

- A Remote Display Connector
- B Power I/O Connector
- C USB Connector



NOTE: Micro video lens model shown. C-Mount model connections are identical.

Table 3: Power I/O Connections

Pin #	Wire Color	Description	Direction
1	White	Output 1	Output

Pin #	Wire Color	Description	Direction
2	Brown	10-30V dc	Input
3	Green	Output 2	Output
4	Yellow	Strobe Out (5V dc only)	Output
5	Gray	Remote Teach	Input
6	Pink	External Trigger	Input
7	Blue	Common (Signal Ground)	Input
8	Red	Ready	Output
9 – 12	multiple	Not used	N/A

Demo Mode

The first time you power up the iVu TG sensor, it starts in Demo Mode and allows you to choose whether to stay in Demo Mode or exit to Live Mode. Demo Mode uses stored images and inspection parameters that demonstrate how the sensor is set up without having to worry about focus, lighting, or triggers. In this mode, you can learn how to make adjustments while working with the different sensor types and observing how the adjustments affect the sensor results. When you exit Demo Mode, the sensor reboots into its normal operating mode with default settings.

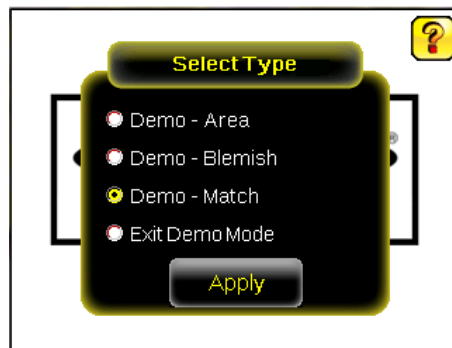

NOTE: You may return to Demo Mode any time by going to Main Menu > System > Sensor Type and selecting Demo Mode.

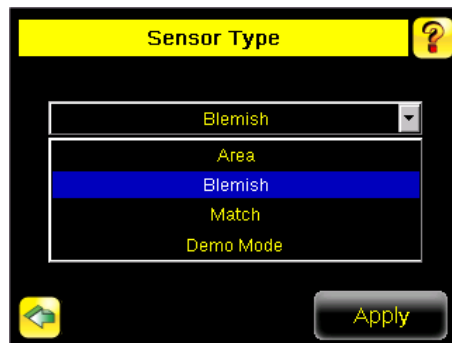

Sensor Types

The iVu TG sensor includes three Sensor Types:

- Area Sensor
- Blemish Sensor
- Match Sensor

Selecting a Sensor Type

When you exit Demo Mode, the sensor reboots with a single inspection with a Match sensor type by default. To change the Sensor Type:

1. Go to Main Menu > System > Sensor Type

This displays the Sensor Type menu options.

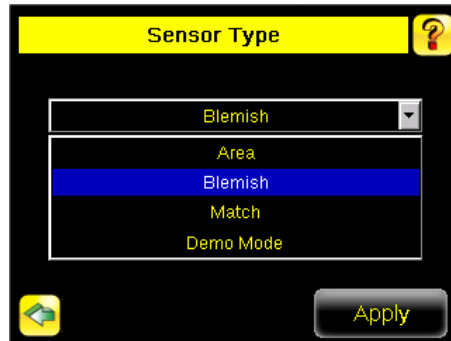

2. Select either Area , Blemish, or Match.

Main Menu

The Main Menu has four sections:

- Inspection—to modify inspection settings
- Imager—to run the Auto Exposure routine and to make adjustments to functions like exposure, gain, and strobe
- System—to select the sensor Type and to manage the device
- Logs—to configure and view System and Inspection Logs

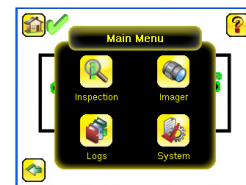

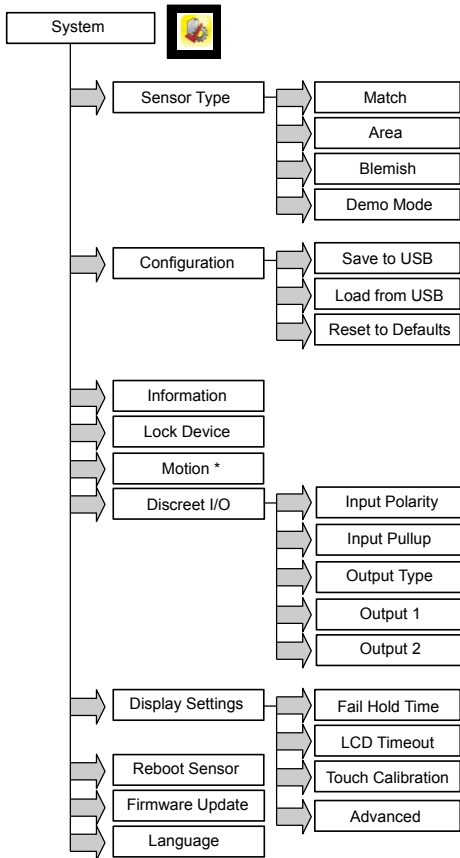

*When Sensor Type = Area or Blemish

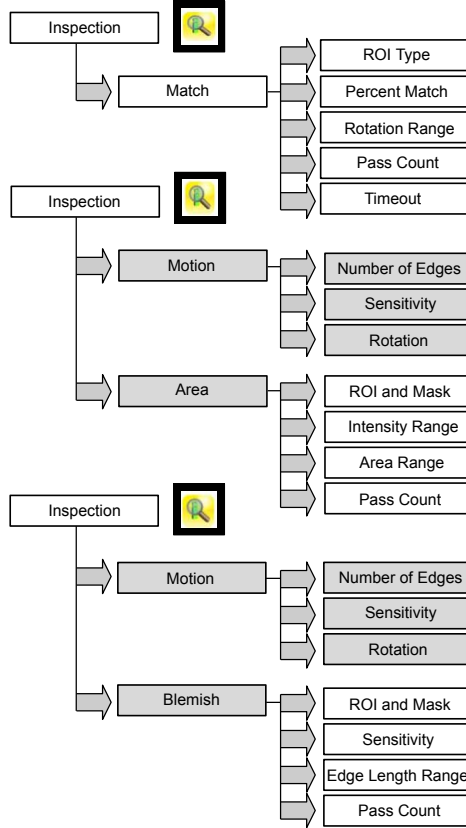

Menu items in gray only display if Motion is Enabled

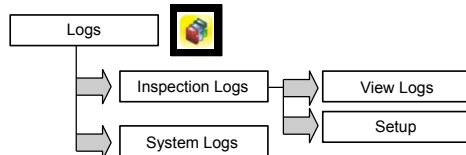
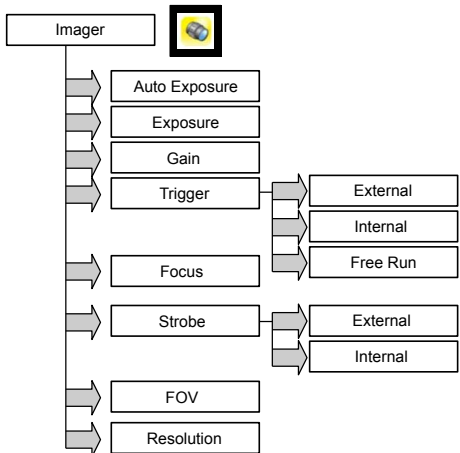



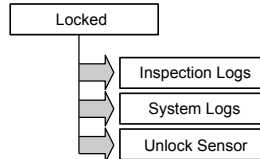



















Locked Sensor Menu Options





Icon Reference







Action Icons

Icon	Description
	The Main Menu icon is displayed on the bottom-left corner of the sensor display on the Home screen. It provides access to sub-menus that are used to set up the sensor.

Icon	Description
	The Inspection menu icon is located on the the Main Menu, and provides access to parameters that need to be set for the current and all stored inspections.
	The Imager menu icon is on the Main Menu, and lists parameters that affect the characteristics of the captured image.
	The System menu icon is on the Main Menu, and is used to manage the sensor.
	The Logs menu icon is on the Main Menu, and is used to set up, view, and save Inspection, Communications, and System Logs.
	The Home Screen icon is displayed in the upper-left corner of the sensor display when viewing menus and parameter screens in the Main Menu. It is used to quickly return to the Home Screen.
	The Display Annotations icon is one of three icons displayed in the upper-left corner of the sensor while monitoring inspections on the Home Screen. Click this icon to highlight features that the sensor finds.
	The Hide Annotations icon is one of three icons displayed in the upper-left corner of the sensor while monitoring inspections on the Home Screen. Click this icon to disable highlighting.
	The Show Statistics icon is one of three icons displayed in the upper-left corner of the sensor while monitoring inspections. Click this icon to show inspection results and input parameters.
	The Hide Log Timestamps icon is one of the icons displayed in the upper-left corner of the Logs screen. Click this icon to hide the time stamp for the Logs.
	The Show Log Timestamps icon is one of the icons displayed in the upper-left corner of the Logs screen. Click this icon to show the time stamp for the Logs.
	The Go Back icon is located on the lower-left of the screen while working in the Main Menu. The Go Back icon is used to return to the previous screen or menu.
	The Help button is located in the upper-right of the screen and provides context-sensitive help for each screen.
	The Manual Trigger icon is located on the lower-right of the sensor display on the Home screen and is used to manually capture a new image.
	The Save icon is used to save data to USB drive, and is available at the bottom of screens such as the Logs screens.
	The Touch Calibration screen displays the Touch Calibration point at various locations on the screen. Every time the icon displays, the user taps the center of the icon to calibrate the screen.
	The Zoom Out icon is located on the right of the screen and is used to reduce magnification of the image being displayed.
	The Zoom In icon is located on the right of the screen and is used to magnify the image being displayed.
	The Intensity Selector is located on the left of the of the Intensity Range screen and is used to select the shade of one of the objects of interest.
	The Decrement icon decreases the currently displayed parameter value by one interval. To quickly decrement the value, press and hold the icon.
	The Increment icon increases the currently displayed parameter value by one interval. To quickly increment the value, press and hold the icon. In the Sort tool, this icon is used to indicate one of the ten storage locations for patterns.
	The Add Mask icon displays on the left side of the screen when masking is enabled. Press to add a mask to the currently selected sensor.
	The Delete Mask icon displays on the left side of the screen when a mask is selected. Press to delete a mask from the currently selected sensor.

Icon	Description
	The Circular Mask icon displays on the left side of the screen when a mask is selected. Press to cycle through and select a Circular, Elliptical, or Rectangular-shaped mask.
	The Elliptical Mask icon displays on the left side of the screen when a mask is selected. Press to cycle through and select a Circular, Elliptical, or Rectangular-shaped mask.
	The Rectangular Mask icon displays on the left side of the screen when a mask is selected. Press to cycle through and select a Circular, Elliptical, or Rectangular-shaped mask.

Display Icons

Icon	Description
	The Inspection Passed icon is located in the upper-left of the screen, and indicates that the last inspection passed its test conditions.
	One of the possible Inspection Failed icons located in the upper-left of the screen, it indicates that the last inspection failed.
	One of the possible Sensor Failed icons located in the Inspection Statistic table, it indicates that the sensor failed because the number of objects exceeded the test count.
	One of the possible Sensor Failed icons located in the Inspection Statistic table, it indicates that the sensor failed because there were fewer objects than specified by the test count.
	One of the possible Sensor Failed icons located in the Inspection Statistic table, it indicates that the sensor failed because the inspection timed out.
	One of the possible Inspection Failed icons located in the upper-left of the screen, it indicates that the sensor is in fail hold mode.
	The Sensor Locked icon is located in the upper-left of the screen, and indicates that the sensor is in a locked state. If no icon is displayed, the sensor is unlocked.

Acquiring a Good Image

The iVu Series sensor needs to capture a good image of each part to ensure that it correctly passes good parts and fails bad parts.

- Go to Main Menu > Imager > Auto Exposure to run the Auto Exposure routine.
- Check the lighting.
 - Make sure that the lighting is constant and consistent (unchanging over time, no shadows or hot spots).
 - Capture the shape and form of the target object with lighting that optimizes its contrast and separates it from the background. Depending on the target, this may mean the integral ring light is not the best choice and other Banner lights should be considered.
 - Adjust the mounting angle to provide the clearest image of the part features you are monitoring. The mounting bracket lets you easily position and adjust the sensor on your line.
- If needed, go to Main Menu > Imager > Auto Exposure to run the Auto Exposure routine a second time or adjust Gain and Exposure manually:
 - Main Menu > Imager > Gain

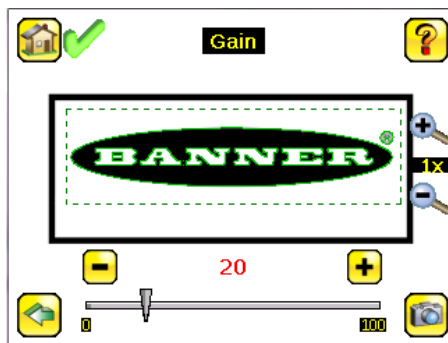

- Main Menu > Imager > Exposure

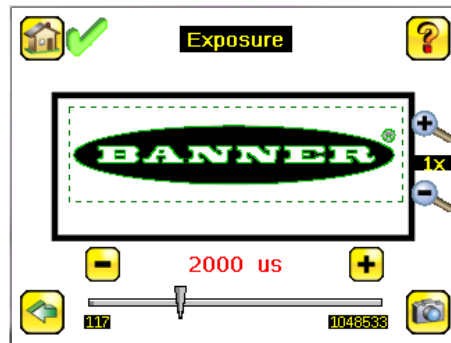

4. Go to Main Menu > Imager > Focus to adjust the focus while monitoring the Focus Number:

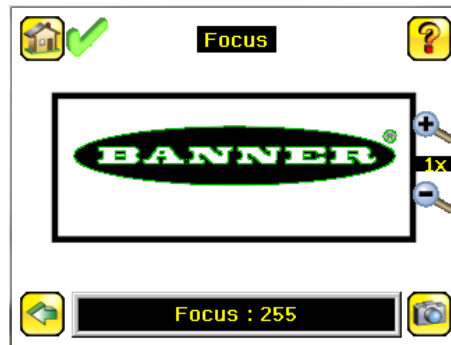

Adjust the Focus on a Micro Video Lens Model

1. Use the supplied 1/16 in. hex key to loosen the Focusing Window locking screw (D), then adjust focus on the iVu Series sensor using the clear Focusing Window (B).
2. Adjust focus while monitoring the focus number. To ensure the best image, adjust the focus until the Focus Number peaks.



NOTE: Turning the Focusing Window counter-clockwise focuses on closer objects, while turning the Focusing Window clockwise focuses on more distant objects.



3. After the best image has been acquired, lock the focusing window.

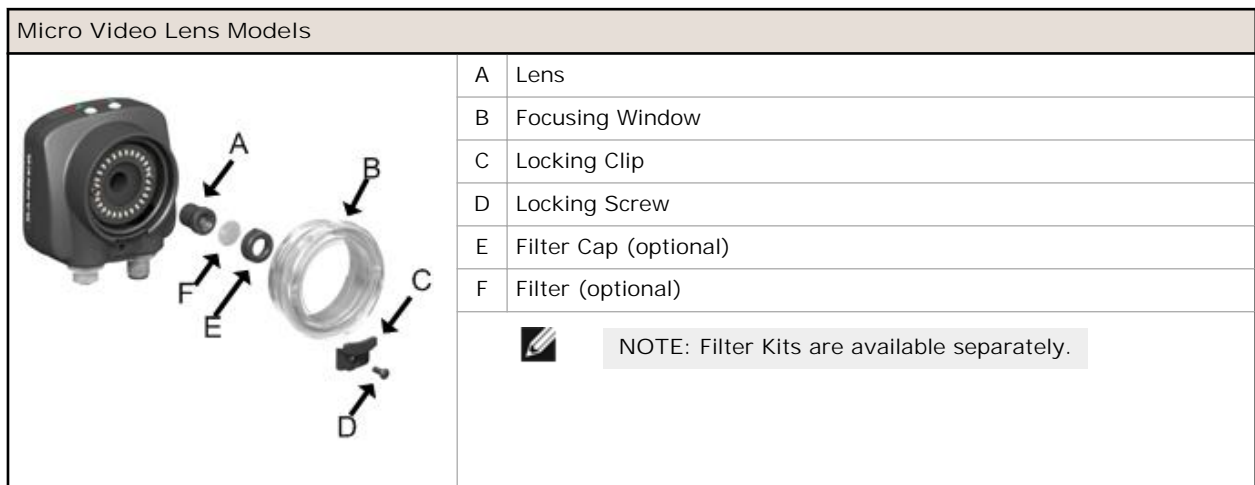

Adjust the Focus on a C-Mount Lens Model

1. Remove the Lens Enclosure.
2. Adjust focus while monitoring the focus number. To ensure the best image, adjust the focus until the Focus Number peaks.
3. Replace the Lens Enclosure on the camera.

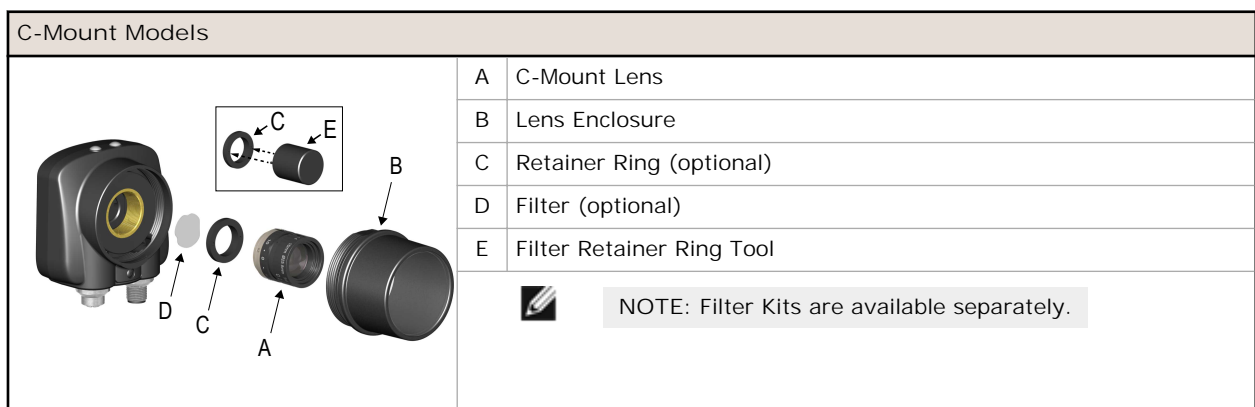

Banner Engineering Corp Limited Warranty

Banner Engineering Corp. warrants its products to be free from defects in material and workmanship for one year following the date of shipment. Banner Engineering Corp. will repair or replace, free of charge, any product of its manufacture which, at the time it is returned to the factory, is found to have been defective during the warranty period. This warranty does not cover damage or liability for misuse, abuse, or the improper application or installation of the Banner product.

THIS LIMITED WARRANTY IS EXCLUSIVE AND IN LIEU OF ALL OTHER WARRANTIES WHETHER EXPRESS OR IMPLIED (INCLUDING, WITHOUT LIMITATION, ANY WARRANTY OF MERCHANTABILITY OR FITNESS FOR A PARTICULAR PURPOSE), AND WHETHER ARISING UNDER COURSE OF PERFORMANCE, COURSE OF DEALING OR TRADE USAGE.

This Warranty is exclusive and limited to repair or, at the discretion of Banner Engineering Corp., replacement. IN NO EVENT SHALL BANNER ENGINEERING CORP. BE LIABLE TO BUYER OR ANY OTHER PERSON OR ENTITY FOR ANY EXTRA COSTS, EXPENSES, LOSSES, LOSS OF PROFITS, OR ANY INCIDENTAL, CONSEQUENTIAL OR SPECIAL DAMAGES RESULTING FROM ANY PRODUCT DEFECT OR FROM THE USE OR INABILITY TO USE THE PRODUCT, WHETHER ARISING IN CONTRACT OR WARRANTY, STATUTE, TORT, STRICT LIABILITY, NEGLIGENCE, OR OTHERWISE.

Banner Engineering Corp. reserves the right to change, modify or improve the design of the product without assuming any obligations or liabilities relating to any product previously manufactured by Banner Engineering Corp.