

Drawings

EJA438E Diaphragm Sealed Pressure Transmitter (Transmitter body section)



SD 01C31J03-01EN

[Style: S1, S2]

Unit: mm (approx. inch)

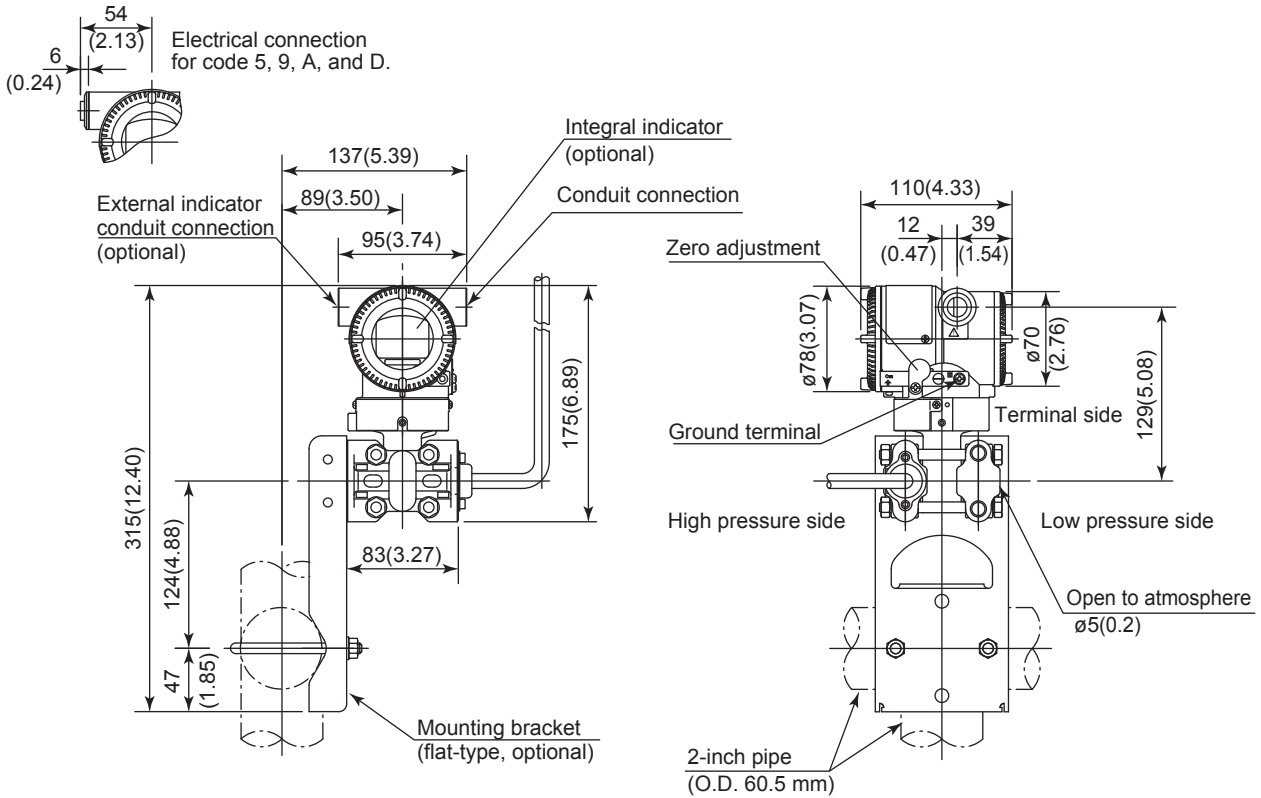

*1: When electrical connection code 7 or C is selected, a blind plug is protruded up to 8 mm from the conduit connection.

- **Terminal Configuration**

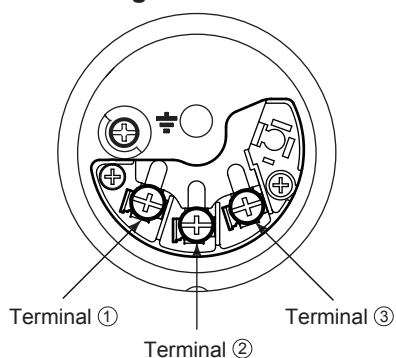

- **Terminal Wiring for 4 to 20 mA output, FOUNDATION Fieldbus and PROFIBUS PA communication types**

| | | | |
|--------|---|---|--|
| SUPPLY | + | ① |] Power supply and output terminals |
| | - | ② | |
| CHECK | + | ③ |] External indicator (ammeter) terminals*1,2 |
| | - | ② | |
| | | | ⏏ Ground terminal |

*1: When using an external indicator or check meter, the internal resistance must be 10 Ω or less.

*2: Not available for FOUNDATION Fieldbus and PROFIBUS PA communication types.

- **Terminal Wiring for 1 to 5 V output**

| | | | |
|--------|---|---|---|
| SUPPLY | + | ① |] Power supply terminals |
| | - | ② | |
| VOUT | + | ③ |] 1 to 5 V DC with HART communication terminals |
| | - | ② | |
| | | | ⏏ Ground terminal |

Three or four wire connection. For four wire connection, both supply and signal lines use SUPPLY - terminal.