**User's
Manual**

**YFGW510
Field Wireless Access Point**

IM 01W02E01-01EN

YFGW510 Field Wireless Access Point

IM 01W02E01-01EN 4th Edition

This document contains important information about using the YFGW510 Field Wireless Access Point properly and safely. Please read this document thoroughly before using this product.

The configuration of the field wireless system is described in the User's Manual of the YFGW410 Field Wireless Management Station (IM 01W02D01-01EN). Read that document first.

CONTENTS

Introduction	i
Safety Precautions	ii
About Radio Wave.....	ii
Documentation Conventions.....	iii
Information of Revision.....	iv

PART-A. OVERVIEW OF FIELD WIRELESS SYSTEM

A1. Introduction.....	A1-1
A2. System Configuration.....	A2-1

PART-B. FUNCTIONS OF YFGW510

B1.	Functions of YFGW510	B1-1
B2.	Structure and Parts of YFGW510.....	B2-1
B2.1	Front View	B2-1
B2.2	Rear View	B2-2
B2.3	Side View.....	B2-4
B3.	LED Display Function	B3-1
B4.	Mechanical Operating Parts.....	B4-1
B5.	Checking the Product	B5-1

PART-C. INSTALLATION

C1.	Installation Environment	C1-1
C2.	Power Supply and Grounding	C2-1
C2.1	Power Supply	C2-1
C2.2	Grounding.....	C2-1
C3.	Requirements for Installation	C3-1
C3.1	Requirements for Installation Locations.....	C3-1
C3.2	Notes on Installation.....	C3-2
C4.	Mounting	C4-1
C5.	Wiring.....	C5-1
C5.1	Power Supply Cable Connection	C5-1
C5.2	Grounding Cable Connection.....	C5-3
C5.3	Network Cable Connection	C5-5
C5.3.1	Metal Network Cable Connection	C5-5
C5.3.2	Optical Network Cable Connection.....	C5-6
C5.4	Installation and Wiring of Antenna.....	C5-8
C5.4.1	Mounting ISA100.11a Antenna to YFGW510	C5-8
C5.4.2	Remote Installation and Wiring of ISA100.11a Antenna	C5-9
C5.4.3	Installation and Wiring of Wireless LAN Antenna	C5-13
C6.	Explosion Proof Wiring.....	C6-1

PART-D. SETUP

D1.	Initial Configuration	D1-1
D2.	Setup Tool	D2-1
D2.1	System Requirements	D2-1
D2.1.1	Hardware	D2-1
D2.1.2	Software	D2-1
D2.1.3	Connection Example.....	D2-2
D2.2	Installation Procedure	D2-3
D2.2.1	Driver for Infrared Adapter	D2-3
D2.2.2	Field Wireless Access Point Setup Tool.....	D2-4
D3.	Configuration Method.....	D3-1
D3.1	Window Design	D3-1
D3.2	Display/Edit Mode Switching.....	D3-2
D3.3	Backbone Interface.....	D3-4
D3.4	Maintenance	D3-6
D3.5	Setting of Wireless LAN 1 (WLAN C1)	D3-8
D3.6	Setting of Wireless LAN 2 (WLAN C2)	D3-11
D3.7	Setting of WLAN Redundancy.....	D3-12
D3.8	Version Information	D3-13

PART-E. OPERATION AND MAINTENANCE

E1.	Routine Maintenance	E1-1
E2.	Additions and Replacements.....	E2-1
E3.	Maintenance in Hazardous Areas.....	E3-1
E4.	Components Having Defined Life Spans	E4-1

PART-F. TROUBLESHOOTING

F1.	Status Information.....	F1-1
F2.	Status Indication and Responsive Measures	F2-1

PART-G. SPECIFICATIONS

G1.	Standard Specifications	G1-1
G1.1	Communication Interface Specifications.....	G1-1
G1.2	General Specifications	G1-2
G1.3	Regulatory Compliance Statements.....	G1-3
G2.	Model, Suffix Codes and Option Codes.....	G2-1
G3.	External Dimensions.....	G3-1
G3.1	100BASE-TX/100BASE-FX Model	G3-1
G3.2	Wireless LAN Single Model	G3-3
G3.3	Wireless LAN Redundant Model	G3-5

Introduction

This document describes the YFGW510 Field Wireless Access Point, which is a core component of field wireless networks. conforming to ISA100.11a, a wireless communication standard for industrial automation that was drawn up by the International Society of Automation (ISA). Outline, setup, settings, start-up, operation and maintenance of the entire field wireless system including the field wireless network and field wireless backbone are described in the User's Manual of the YFGW410 Field Wireless Management Station (IM 01W02D01-01EN). Read that document first.

Safety Precautions



IMPORTANT

Read the safety precautions for this product that are described in YFGW510 Field Wireless Access Point Read Me First (IM 01W02E01-11EN).

About Radio Wave



IMPORTANT

Read the safety precautions for this product that are described in YFGW510 Field Wireless Access Point Read Me First (IM 01W02E01-11EN).



IMPORTANT

- This product is equipped with a wireless module which is designated as a certification of construction type as a wireless facility for 2.4 GHz band low-power data communication system of the Radio Act.
Refer to G1.3 Regulatory Compliance Statements for detail.
Due to the designated certification of construction type, users may be subject to legal punishment in case of:
 - Disassembling or modifying the wireless module or antenna in this instrument
 - Peeling off the certification label attached to the wireless module in this instrument
 - RF Transmitter Power
The factory default settings of RF transmitter power is depends on the antenna type for ISA100.11a.
ISA100.11a antenna code: 1
RF transmitter power is 7.9 dBm (9.9 dBm EIRP with +2 dBi antenna)
ISA100.11a antenna code: A
RF transmitter power is 0.9 dBm (9.9 dBm EIRP with +9 dBi antenna)
RF transmitter power depends on the region and the antenna type. In order for the wireless output of an antenna to get the maximum which the area permits, adjustment by service of Yokogawa is required.
 - Microwave ovens and other industrial, scientific and medical equipment, as well as local wireless stations (license required) and specific low-power wireless stations (license not required) for identifying mobile objects used in the production line of a factory, use the same frequency band as this product. Prevent interference with other wireless stations.
 - Check that local wireless stations and specific low-power wireless stations are not being used in the vicinity before using this product.
 - If this product causes radio interference in a local wireless station used for identifying mobile objects, change the working frequency or stop the emission of radio waves immediately. For details on how to prevent radio interference, contact our service office.
 - Although this product has been designed to resist high frequency electrical noise, if a radio transceiver is used near the transmitter or its external wiring, the transmitter may be affected by high frequency noise pickup. To test this, start out from a distance of several meters and slowly approach the transmitter with the transceiver while observing the measurement loop for noise effects. Thereafter use the transceiver outside the range where the noise effects were first observed.
-

Documentation Conventions

■ Typographical Convention

The following typographical conventions are used throughout this document:

● Conventions commonly used throughout this document

Character string to be entered

The characters to be entered are shown in one-byte characters as follows:

Example:

```
FIC100.SV=50.0
```

“△”Mark

Indicates a space between character strings to be entered.

Example:

```
.AL △ PIC010 △ -SC
```

Character string enclosed by brackets ({ })

Indicates an option that can be omitted.

Example:

```
.PR △ TAG {△. Sheet name}
```

● Conventions used to show key or button operations:

Characters enclosed by brackets ([])

Characters enclosed by brackets within any description on a key or button operation, indicate either a key on the HIS (Human Interface Station) keyboard, a key on the operation keyboard, a button name on a window, or an item displayed on a window.

Example:

To perform the function, press the [OK] key.

Characters enclosed by angle-brackets (<>)

Characters enclosed by angle-brackets show the title of the screen during explanation of the software operation.

■ Symbols

The symbols used in this document are described in YFGW510 Field Wireless Access Point Read Me First (IM 01W02E01-11EN).

■ Drawing Conventions

Some drawings may be partially emphasized, simplified or omitted for the convenience of description.

Some screen images depicted in the user's manual may have different display positions or character types (e.g., upper/lower case). Also note that some of the images contained in this user's manual are display examples.

Information of Revision

Document Name: YFGW510 Field Wireless Access Point

Document Number: IM 01W02D01-01EN

Edition	Date	Page	Revised Item
1st	August 2012	–	New Issue
2nd	February 2013	– C5-9 C5-13	Procedure of installing remote antennas is revised by changing the antenna bracket. C5.4.2 figure and procedure of fastening remote ISA100.11 a antenna are updated C5.4.3 figure and procedure of fastening Wireless LAN antennas are updated
3rd	March 2016	– D2-1	Add ATEX/IECEX Flameproof Certification. Support OS list is updated.
4th	February 2018	C5-3 G1-3	Add a warning message about grounding. Update CE Conformity.

PART-A. OVERVIEW OF FIELD WIRELESS SYSTEM

A1. Introduction

Read the User's Manual (IM 01W02D01-01EN) of the YFGW410 Field Wireless Management Station (hereafter simply referred to as YFGW410) before reading this document.

The YFGW510 Field Wireless Access Point (hereafter simply referred to as YFGW510) is a core component of field wireless networks based on ISA100.11a, a wireless communication standard for industrial automation. YFGW510 serves as an access point and forms the wireless backbone network for the YFGW410 and the YFGW610 Field Wireless Media Converter (hereafter simply referred to as YFGW610).

A2. System Configuration

This chapter describes the configuration for the field wireless system including YFGW510.

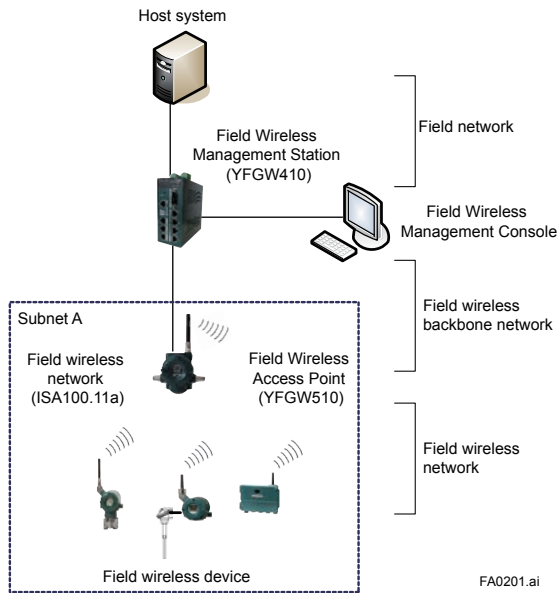

Figure A2-1 Minimum configuration

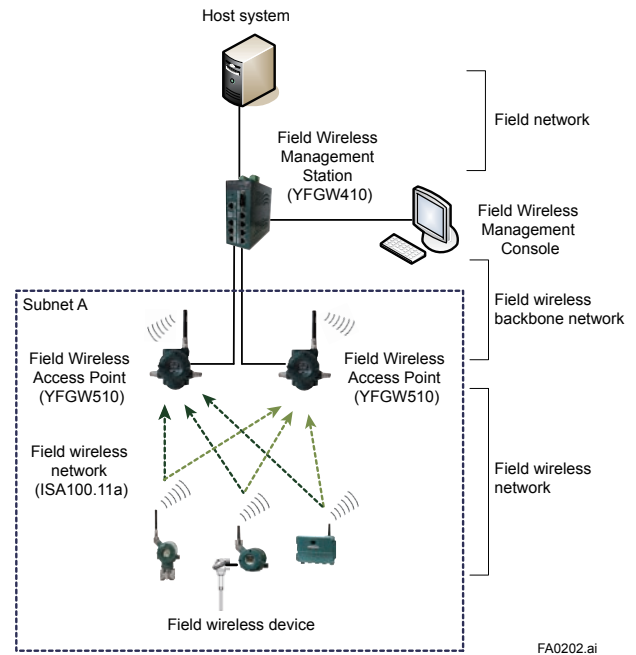
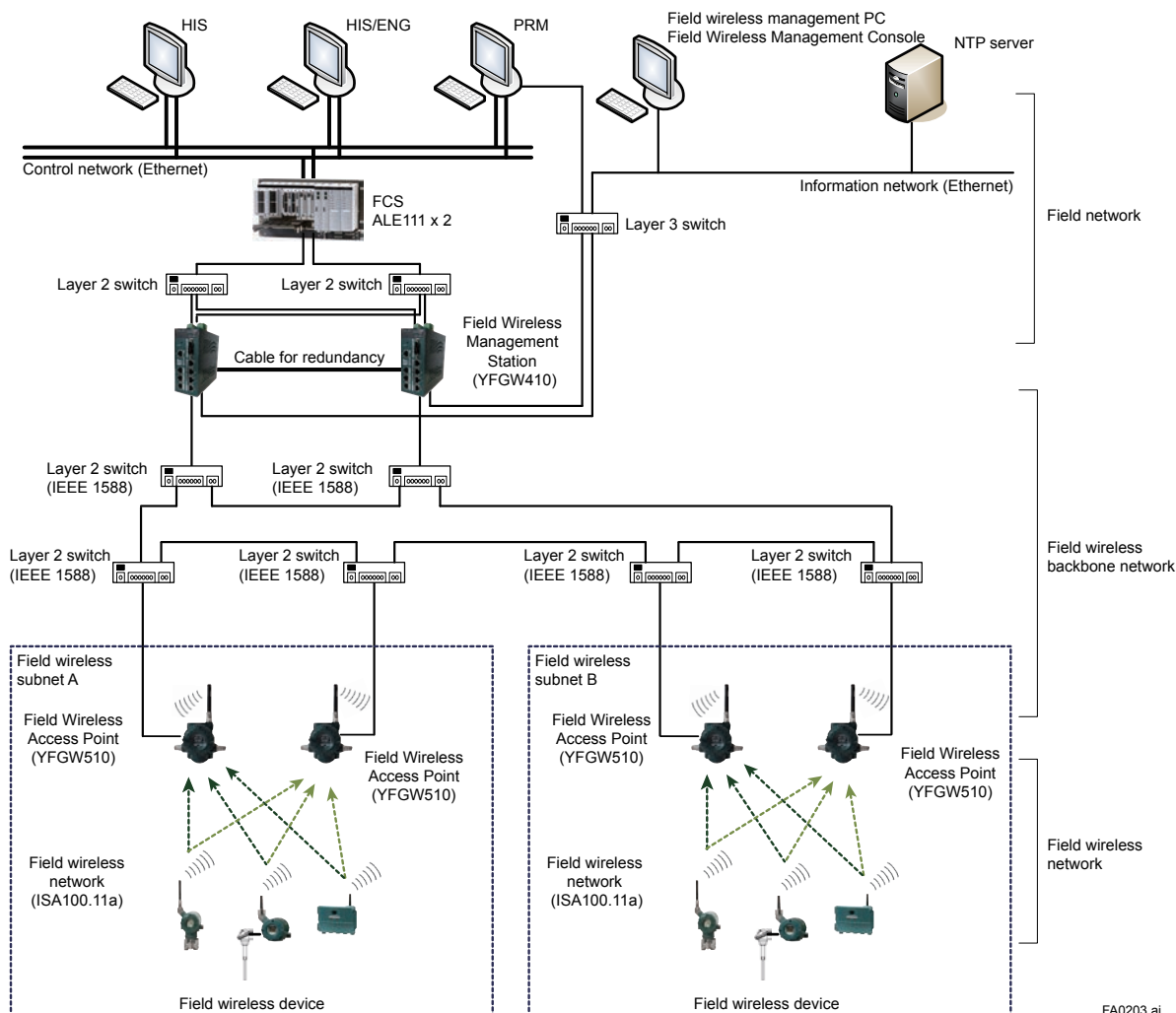

Figure A2-2 YFGW510-redundant configuration

Figure A2-1 shows the minimum configuration with a single YFGW510, and Figure A2-2 shows the YFGW510-redundant configuration supported the Duocast technology (each field wireless device communicates with two YFGW510s).

The field wireless backbone network consists of the YFGW410, the YFGW510 and the YFGW610. Any of the following connection methods can be selected.

1. Metal network connection (100BASE-TX)
2. Optical fiber network connection (100BASE-FX)
YFGW610 must be installed between YFGW510 and YFGW410 for optical fiber network connection to convert it to metal network connection.
3. Wireless LAN connection
Recommended access points for wireless LAN must be installed between YFGW510 and YFGW410 for wireless LAN connection to convert it to metal network connection.
For recommended wireless LAN access points, see the User's Manual of YFGW410 (IM 01W02D01-01EN).



FA0203.ai

Figure A2-3 YFGW410/YFGW510-redundant configuration

Figure A2-3 shows the YFGW410/YFGW510-redundant system configuration.

The Layer 2 switch between YFGW410 and YFGW510 must support the rapid spanning tree protocol (RSTP) to prevent network loops, and the IEEE1588v2 (precision time protocol).

For recommended Layer 2 switches, see the User's Manual of YFGW410 (IM 01W02D01-01EN).

As shown above, field wireless networks can be built with various system configurations.

PART-B. FUNCTIONS OF YFGW510

B1. Functions of YFGW510

The following block diagrams show communication functions of YFGW510 for each model.

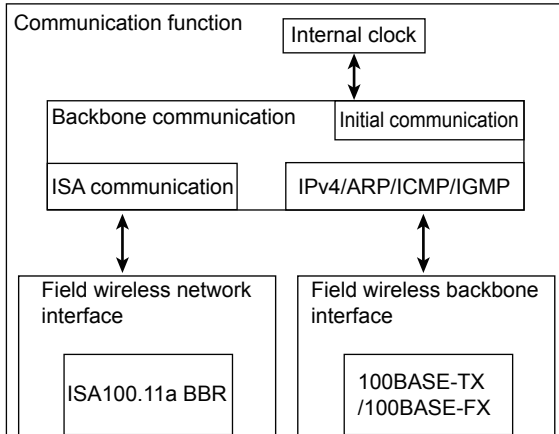

FB0101.ai

Figure B1-1 100BASE-TX/100BASE-FX model

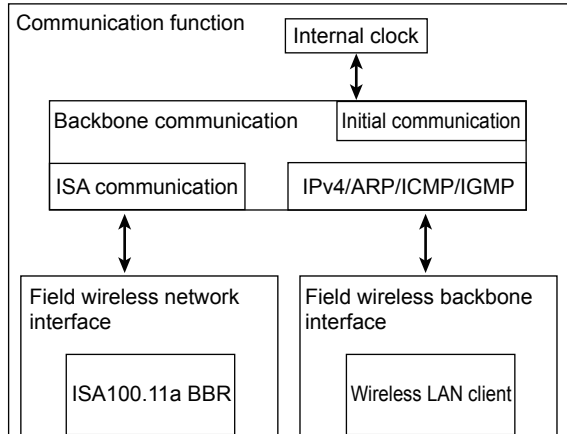

FB0102.ai

Figure B1-2 Wireless LAN single model

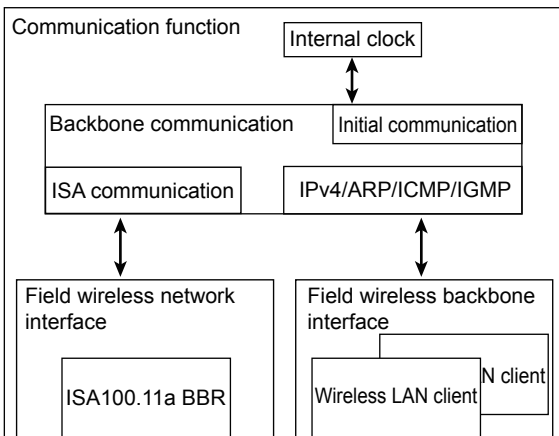

FB0103.ai

Figure B1-3 Wireless LAN redundant model

As shown above, the functions of the field wireless backbone interface differ depending on model.

YFGW510 with the 100BASE-FX model is equipped with a media converting board for metal network/optical fiber network. The metal network cable and optical fiber network cable cannot be used at the same time.

In the wireless LAN client model, neither metal network cable nor optical fiber network cable can be used. Wireless LAN client model indicates both of the wireless LAN single model and the wireless LAN redundant model.

YFGW510 with the wireless LAN redundant model uses either wireless LAN port as a communication path. For the selection of a wireless LAN port and the conditions for switching communication paths, see D3.7 Setting of WLAN Redundancy.

ISA100.11a BBR of the field wireless network interface is for the field wireless communication.

Initial communication shown in the block diagram is the function of setting parameters. It communicates to the Field Wireless Access Point Setup Tool via an infrared port through the glass window on the front face of YFGW510.

B2. Structure and Parts of YFGW510

B2.1 Front View

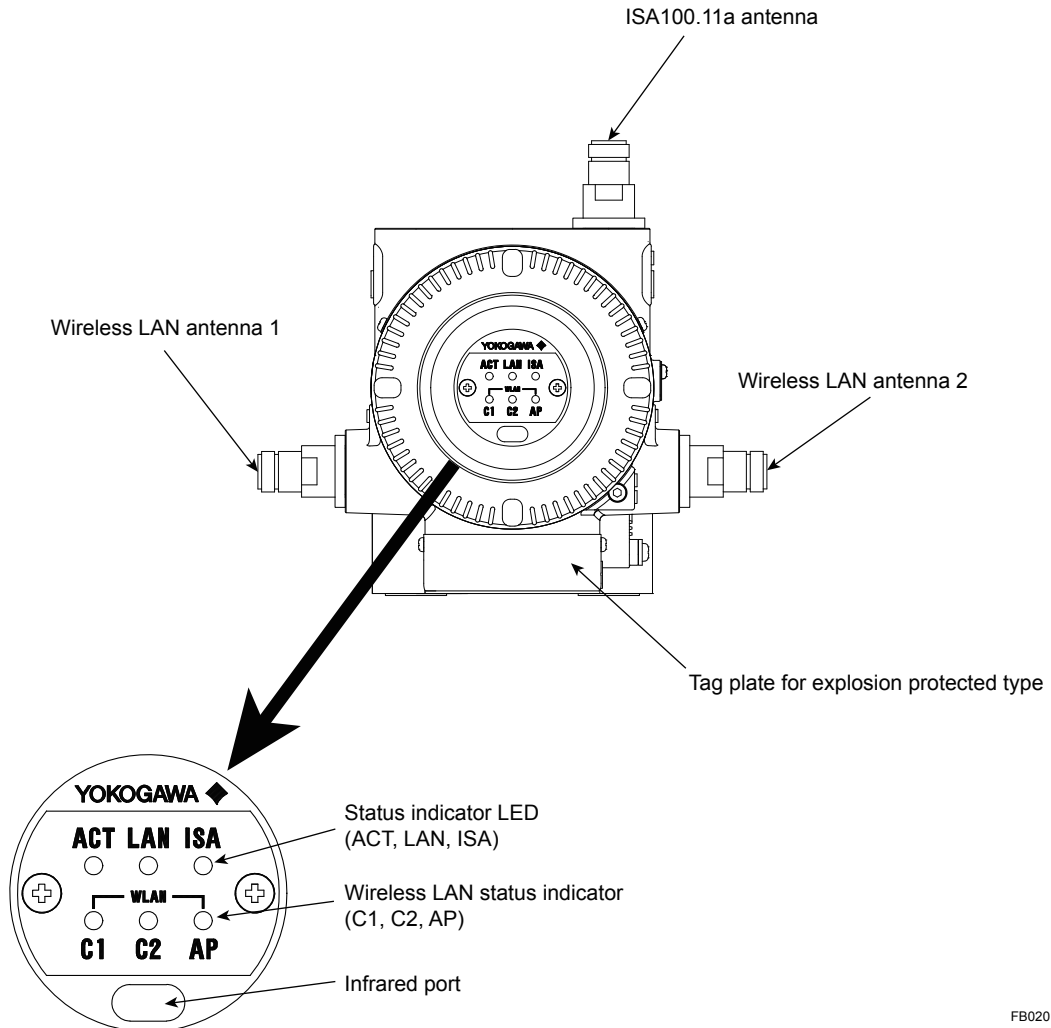

FB0201.ai

Figure B2-1 Front view

One to three antenna connectors are provided, depending on the model. For all models, the ISA100.11a antenna connector is on top. The wireless LAN antenna connector 1 on the left side of the housing is for the wireless LAN single model and the antenna connector 2 is added on the right side for the wireless LAN redundant model.

The ISA100.11a antenna can be directly mounted on the connector, or remotely connected by using an extension cable. The wireless LAN antenna(s) must be placed vertically and more than 1 m apart from the ISA100.11a antenna. Thus, they must be connected by using antenna extension cables.

YFGW510 does not have any switches or buttons that can be mechanically operated from the outside of the housing.

B2.2 Rear View

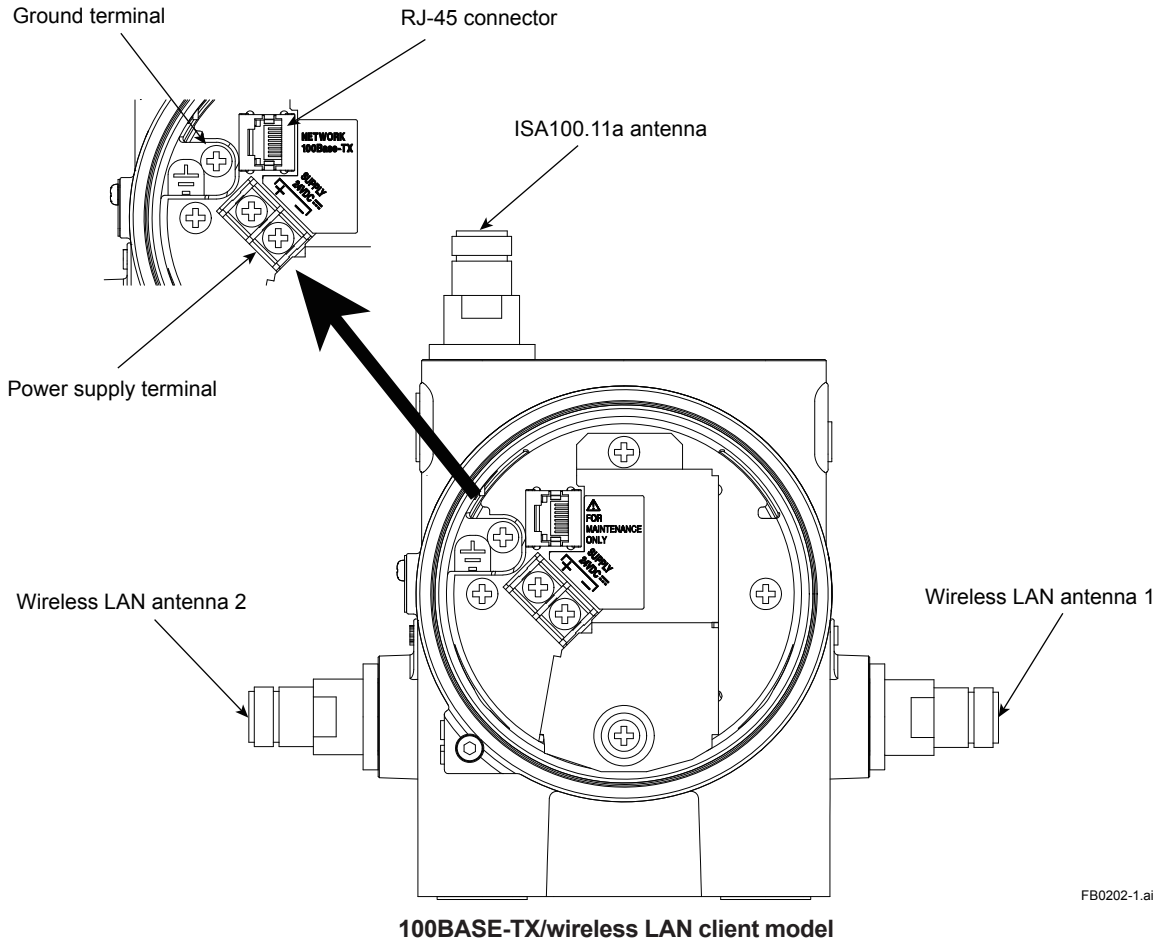

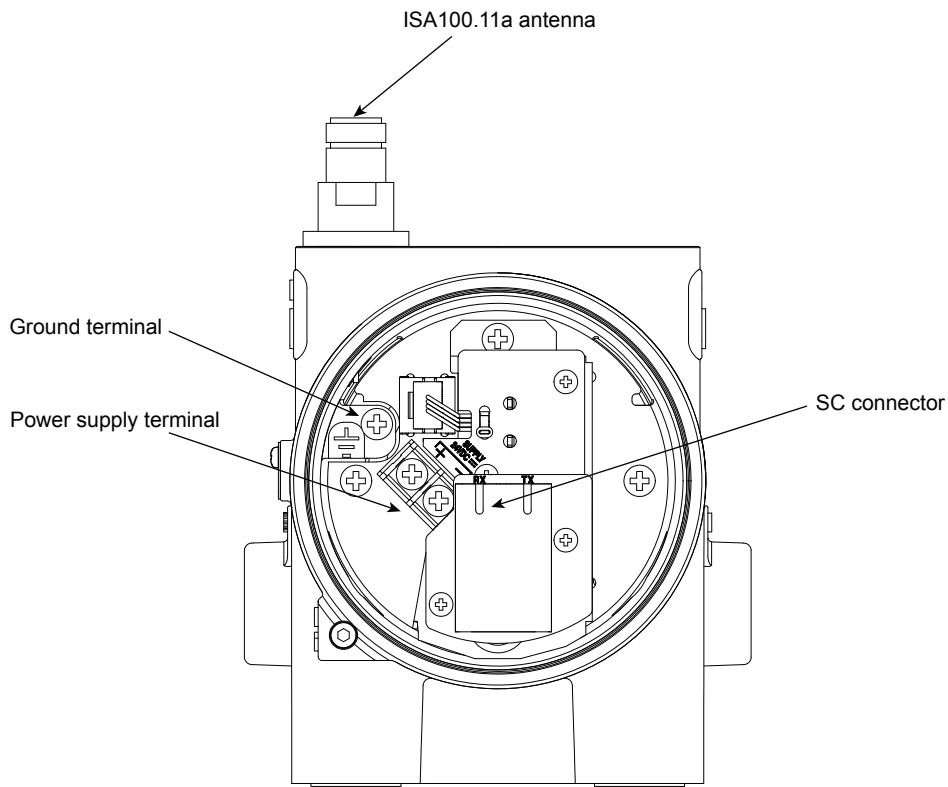

100BASE-FX model

FB0202-2.ai

Figure B2-2 Rear view of YFGW510

The power supply cable, grounding cable and communication cable are connected on the back face of YFGW510. The electrical connection is provided on the bottom.

In the 100BASE-FX model, a media converter module is added to the 100BASE-TX model.

Although the RJ-45 connector is provided in the wireless LAN client model, it is for maintenance only and cannot be used for communication.

B2.3 Side View

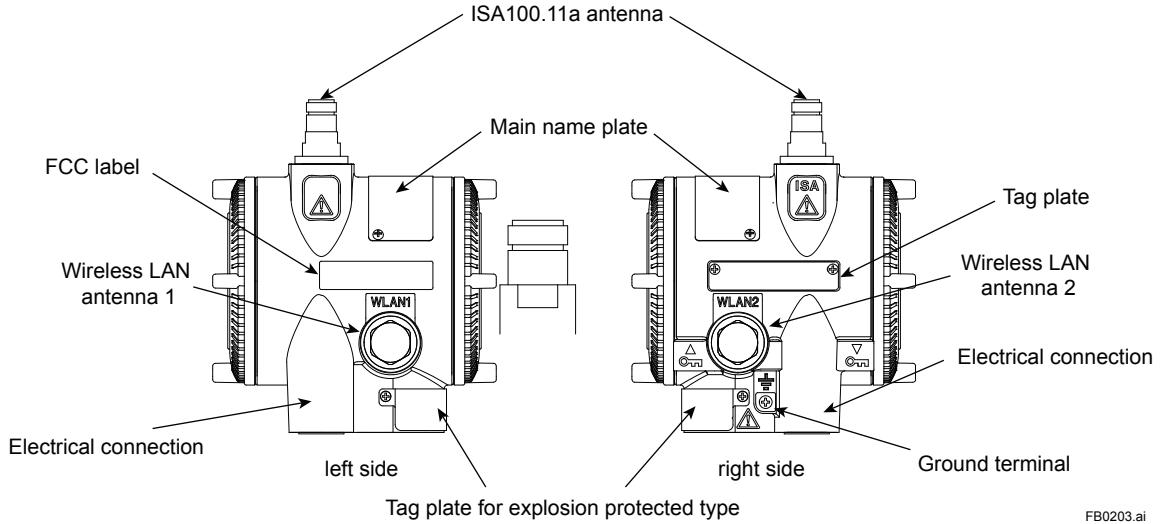

FB0203.ai

Figure B2-3 Side view of YFGW510

The wireless LAN antenna connector(s) are equipped on the side(s) only for wireless LAN client model.

B3. LED Display Function

- The functions of the status indicator LED on the front face are as follows.

LED	Function
ACT	Display the status of YFGW510
LAN	Display the status of the communication interface (100BASE-TX/100BASE-FX)
ISA	Display the status of ISA100.11a antenna
C1	Display the status of wireless LAN antenna 1
C2	Display the status of wireless LAN antenna 2
AP	Not used for YFGW510

■ Displaying the operation status

The relation of the operation status and LED status is as follows.

LED	Power off	Starting up	Connect- ing	Normal	Mainte- nance	Abnormal
ACT	OFF	Orange	Orange blink	Green	Red blink	Red

Details of the device status are as follows.

Status	Description
Power off	Power supply is OFF.
Starting up	Power supply is turned on and initializing the device.
Connecting	Startup has completed and try to connect to the network.
Normal	The results of the self-diagnosis (communication, operation) are normal.
Maintenance	Setting parameters. Communicates to the Field Wireless Access Point Setup Tool via an infrared port.
Abnormal	Any of the results of the self-diagnosis (communication, operation) is abnormal.

■ Displaying the communication status

The relation of the communication status and LED status is as follows.

LED	Power off	Starting up	Signal search	Link down	Link up	Commu- nicating	Mainte- nance	Abnor- mal
LAN	OFF	OFF	N/A	OFF	Green	Green blink	OFF	Red
ISA	OFF	OFF	N/A	N/A	Green	Green blink	OFF	Red
WLAN-C1	OFF	OFF	Orange blink	OFF	Green blink	Green	OFF	Red
WLAN-C2	OFF	OFF	Orange blink	OFF	Green blink	Green	OFF	Red
WLAN-AP	—	—	—	—	—	—	—	—

B4. Mechanical Operating Parts

YFGW510 does not have any switches or buttons that can be mechanically operated from outside of the housing.

B5. Checking the Product

When you receive YFGW510, please check that the product specifications match your order, all items are included and that there is no damage, stains or other problems.

■ Main unit

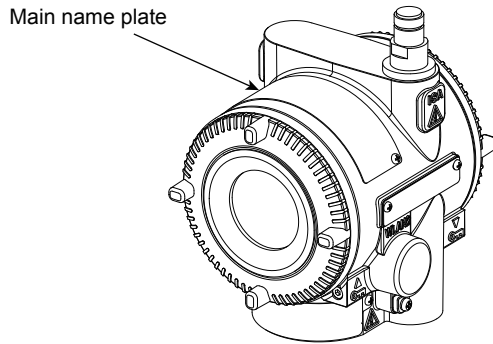

FB0501.ai

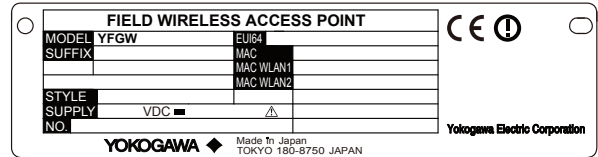

FB0502.ai

■ Standard accessories

- **Manual (IM01W02E01-11EN YFGW510 Field Wireless Access Point Read Me First)**

When specified manual language as an english.

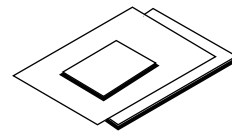

FB0503.ai

- **Software media (F9195TA)**

When specified software media as DVD-ROM.

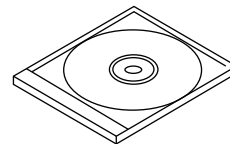

FB0504.ai

- **Mounting bracket**

When models with the mounting bracket specified.

- **ISA100.11a antenna**

When specified integral antenna 2dBi.

- **Wireless LAN antenna 1 mounting kit**

When specified remote antenna 2dBi, antenna cable 3m with mounting bracket.

- **Wireless LAN antenna 2 mounting kit**

When specified remote antenna 2dBi, antenna cable 3m with mounting bracket.

PART-C. INSTALLATION

This part describes installation for YFGW510.

Follow the steps below to use of the product.

1. Installation of YFGW510
2. Wiring of the power supply, grounding cable, signal cables and mounting/wiring of antenna(s)

C1. Installation Environment

YFGW510 should be installed in appropriate conditions to ensure its stable operation.

The table below shows details of the installation environment for YFGW510.

Item		Environment	Note
Power supply	Rated voltage	24 V DC	
	Voltage range	10 to 26.4 V DC	
	Momentary power failure	1 ms or less (instant disconnection)	
	Ripple ratio	1%p-p or less	
Terminal		M4 screw terminal (power supply and ground)	
Maximum power consumption		3.5 W	
Grounding		Class D grounding (100 Ω or less)	No sharing with other devices
Temperature range	Operating	-40 to 65°C	
	Transport/storage	-40 to 85°C	
Humidity range	Operating	5 to 95% RH (No condensation)	
	Transport/storage	5 to 95% RH (No condensation)	
Temperature gradient	Operating	±10°C/h or less	JEIDA29 class B
	Transport/storage	±20°C/h or less	
Protection degree		IP66	IEC529
Vibration resistance		Displacement amplitude: 0.21 mm (10 to 60 Hz)	
		Acceleration amplitude: 3 G (60 to 2000 Hz)	
Shock resistance		50 G 11 ms (de-energized, with half-sine wave pulse in three directions)	IEC68-2-27
Altitude		3000 m or less	
Noise resistance	Electric field	3 V/m or less (80 MHz to 1 GHz)	
	Electrostatic discharge	4 kV or less (contact discharge), 8 kV or less (aerial discharge)	
Cooling		Natural air cooling	
Mounting		2-inch pipe	With dedicated brackets



IMPORTANT

- Avoid exposing the YFGW510 to direct sunlight.
- Avoid iron flakes, carbon particles, or any other type of dust that are conductive.
- Avoid existence of corrosive gases such as hydrogen sulfide, sulfurous acid gas, chlorine, and ammonia.

**IMPORTANT**

This product is equipped with a wireless module which is designated as a certification of construction type as a wireless facility for 2.4 GHz band low-power data communication system of the Radio Act.

Refer to G1.3 Regulatory Compliance Statements for detail.

Before use, confirm that the location of installation satisfies the above standard.

**IMPORTANT**

- Microwave ovens and other industrial, scientific and medical equipment, as well as local wireless stations (license required) and specific low-power wireless stations (license not required) for identifying mobile objects used in the production line of a factory, use the same frequency band as this product. Prevent interference with other wireless stations.
 - Check that local wireless stations and specific low-power wireless stations are not being used in the vicinity before using this product.
 - If this product causes radio interference in a local wireless station used for identifying mobile objects, change the working frequency or stop the emission of radio waves immediately. For details on how to prevent radio interference, contact our service office.
-

**WARNING**

- To satisfy degree of protection provided by enclosure IP66, apply suitable devices to the electrical connection port.
-

C2. Power Supply and Grounding

An appropriate power supply is necessary for the stable operation of YFGW510.

C2.1 Power Supply

Connect the power source to the power supply terminal in the device.

SEE ALSO For details of the power supply and power consumption of YFGW510, see C1. Installation Environment.

Inrush Current

When starting up, inrush current may run into the device. As shown in the table below, this current is, even though short-lived, significantly larger (10 times or more) than the steady state current. Make sure that the power supply and protector can endure the inrush current.

Item	Specification	Remarks
Inrush current	8 A (5 ms or less)	At 26.4 V DC

SEE ALSO For details of power supply wiring, see C5.1 Power Supply Cable Connection.



IMPORTANT

YFGW510 does not have a power switch. Provide a breaker or switch for the power line to turn ON/OFF the device.

- Configuration data may be corrupted if a power failure occurs during download to YFGW410, YFGW510 and field wireless devices. Configuration data is not corrupted even if a power failure occurs at the time of the usual operation.
- Please supply the power from the permanent power supply to avoid.

C2.2 Grounding

Appropriate grounding is necessary for the stable operation of YFGW510. Class D grounding (the third class grounding) with the grounding resistance of 100 Ω or less is necessary. To connect the grounding cable to YFGW510 directly, use the ground terminal on the right side of the housing.

SEE ALSO For details of ground wiring, see C5.2 Grounding Cable Connection.

C3. Requirements for Installation

C3.1 Requirements for Installation Locations

The installation of YFGW510 and field wireless devices must meet the following conditions:

- The field wireless equipment should be mounted in the place where no obstacle exists around the antenna. Especially, YFGW510 should be mounted in the condition that no obstacle exists around the antenna.
- If there is a pipe for mounting or plumbing in the direction except for the communication partners, the antenna should be more than 30 cm apart from them.
- When the wireless LAN antenna or field wireless antenna do not meet above requirements, use an extension cable to place the antenna where radio waves will not be affected by obstacles.
- All antennas must be in the upright position.
- The antenna of field wireless equipment must be installed at least 1.5 m above the ground (floor)
- The YFGW510 should be installed at a location as close as possible to the center of the field wireless network.
- Ensure that the field wireless devices that are located within the wireless communication range are within the line of sight of each other. In the star topology, the YFGW510 must meet this condition.

C3.2 Notes on Installation

Pay attention to the following points at the installation of YFGW510 and field wireless devices.

■ Installation Location

This device is designed to work under the severe environmental condition. However, it is necessary to pay attention to the following conditions for the stable and long-term precise operation.

● Exposure to Direct Sunlight

If the device is placed at a location that may be exposed to direct sunlight, it is necessary to make the insulation measure. However, the antenna must be covered with the material which does not block the radio wave.

● Ambient Temperature

Avoid locations subject to wide temperature variations or a significant temperature gradient. If the location is exposed to radiant heat from plant equipment, provide adequate thermal insulation and/or ventilation. Do not install the device in a location where high temperature and high humidity may last for a long time.

● Ambient Atmosphere

Do not install the device in a corrosive atmosphere. If this cannot be avoided, there must be adequate ventilation as well as measures to prevent the rain water from penetrating or remaining in the conduits.

● Vibration and Impact

Although the device is designed to be resistant to vibration and impact, an installation site should be selected where vibration and impact are kept to a minimum.

■ Installation of Explosion Proof Compliant Device

The explosion proof compliant equipment can be installed in the hazardous area of specific gases. This device must be installed in accordance with the regulations of the country where the device is installed.

- Installation: Check that the ambient temperature is not beyond the limit.
- Wiring: Put all the power cables in protective ducts. If possible, also put the network cables (optical fiber cable or metal cable) in protective ducts.
- Maintenance: After confirming that there is no dangerous gas in the ambience, open the housing or protective ducts.

C4. Mounting

Mount YFGW510 on the 2-inch pipe, placed vertically or horizontally, using the dedicated bracket. Make sure that the 2-inch pipe, the device, connectors or cables will be interfered each other, because YFGW510 is accessed through its four or six sides. YFGW510 does not support any other mounting method.

■ Mounting on vertical pipe (Communications interface: 100BASE-TX/100BASE-FX)

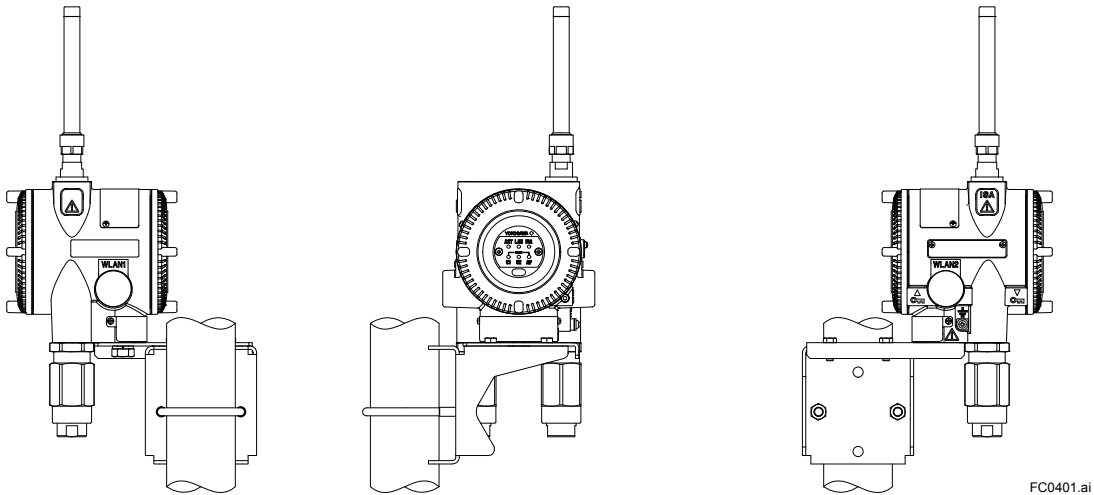

Figure C4-1 Mounting on vertical pipe (Communications interface: 100BASE-TX/100BASE-FX)

Assemble the bracket and attach YFGW510 to the bracket. Fasten it to the pipe using the U-bolts.

For wiring procedure using cable connectors, see the section on wiring.

■ **Mounting on vertical pipe (Communications interface: Wireless LAN client)**

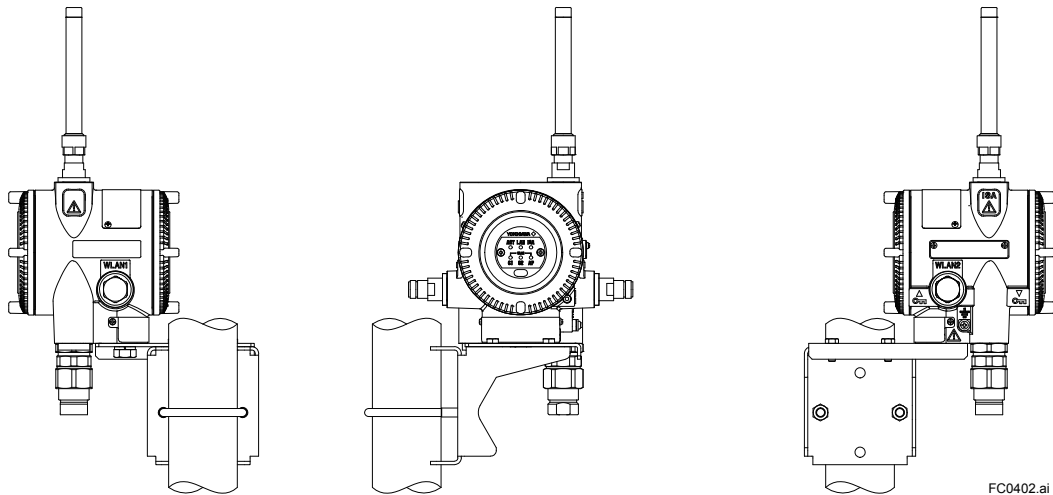

Figure C4-2 Mounting on vertical pipe (Communications interface: Wireless LAN client)

When used for the wireless LAN single model, YFGW510 is equipped only with the connector for wireless LAN antenna on the left side of the housing.

Assemble the bracket and attach YFGW510 to the bracket. Fasten it to the pipe using the U-bolts.

For wiring procedure using cable connectors, see the section on wiring.

The wireless LAN antenna(s) must be placed away from the ISA100.11a antenna, using an extension cable. For details, see the section on antenna installation

■ **Mounting on horizontal pipe (Communications interface: 100BASE-TX/100BASE-FX)**

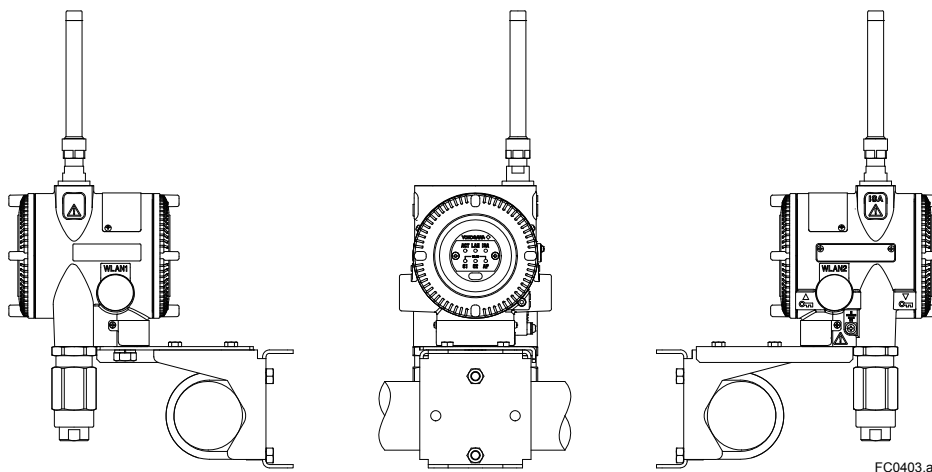

Figure C4-3 Mounting on horizontal pipe (Communications interface: 100BASE-TX/100BASE-FX)

Assemble the bracket and attach YFGW510 to the bracket. Fasten it to the pipe using the U-bolts.

For wiring procedure using cable connectors, see the section on wiring.

■ **Mounting on horizontal pipe (Communications interface: Wireless LAN client)**

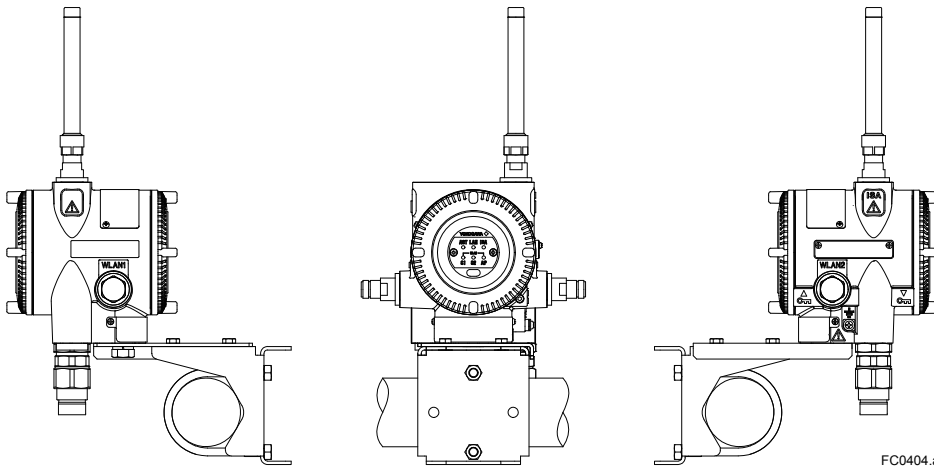

Figure C4-4 Mounting on horizontal pipe (Communications interface: Wireless LAN client)

For use with the wireless LAN single model, YFGW510 is equipped only with the connector for a wireless LAN antenna on the left side of the housing.

Assemble the bracket and attach YFGW510 to the bracket. Fasten it to the pipe using the U-bolts.

For wiring procedure using cable connectors, see the section on wiring.

The wireless LAN antenna(s) must be placed away from the ISA100.11a antenna, using an antenna extension cable. For details, see the section on antenna installation.

C5. Wiring

This chapter describes connection of the power supply cable, grounding cable and network cable to the installed YFGW510, mounting of antennas and cable connection.

- With the cable wiring to the electrical connection port, use a metallic conduit or waterproof glands.
- Apply a non-hardening sealant to the electrical connection port and to the threads on the metal conduit for waterproofing.
- There must be measures to prevent the rain water from penetrating or remaining in the conduits.
- Use cables with a 70°C rating or higher for explosion-proof devices.
- Explosion-proof device must be wired in compliance with related laws and regulations.

C5.1 Power Supply Cable Connection

This section describes power supply cable wiring.

● Wiring

Pull the power supply cable into the device through the power cable ground. Connect the power supply cable to the power supply terminal in the device.

● Recommended power supply capacity

Output voltage range: 12 to 24V DC (Supplied from power supply to YFGW510)

Output capacity: 10 W or more *

* When starting up YFGW510, an inrush current flows as described in C2.1 Power Supply. Make sure that the power source has current output capacity at least three times normal current consumption and enough to withstand the inrush current as described below.

● Inrush current

When power is turned on, an input current flows, which is higher than its normal state. See C2.1 Power Supply about inrush current. Ensure that the power supply and protective devices can withstand this current.

● Cable (Insulated for industrial equipment)

Examples

- 600 V polyvinyl chloride insulated wires (IV): JIS C3307
- Polyvinyl chloride insulated wires for electrical apparatus (KIV): JIS C3316
- 600 V grade heat-resistant polyvinyl chloride insulated wires (HIV): JIS C3317
- Heatproof vinyl insulated wires VW-1 (UL1015/UL1007)

Wire size

- Core: AWG14 to 13 (2 to 2.6 mm²)

Terminal treatment

- Ring terminal for M4: With insulation covers

● **Power supply cable connection procedure**

1. Insert the power supply cable through the power supply cable gland into the housing.
2. Screw the cable gland into the housing to fasten it.
3. Connect the + cable to the + terminal and the – cable to the – terminal.
4. For shielding the power supply cable, connect the grounding cable to the ground terminal next to the power supply terminal.

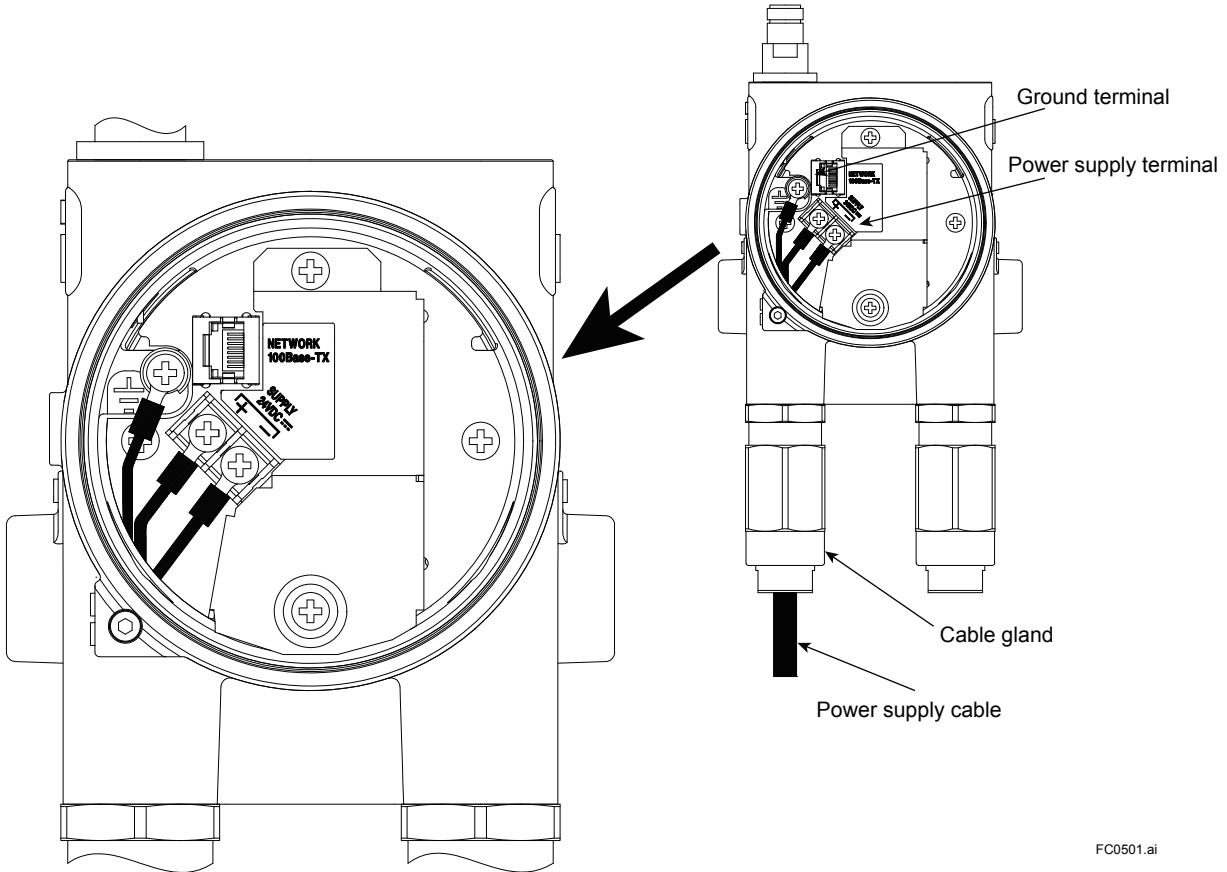

Figure C5-1 Connecting power supply cable

FC0501.ai

C5.2 Grounding Cable Connection

This section describes ground wiring.

Class D grounding (the third class grounding) with the grounding resistance of 100 Ω or less is necessary. To connect the grounding cable to YFGW510 directly, use the ground terminal on the right side of the housing. Do not share the ground wiring with other devices.



WARNING

Proper grounding is necessary to maintain the function and performance of this product. When the grounding is inadequate, the equipment may be damaged. Refer to TI 01W01A58-01EN for details of grounding method and precautions.

- Use a grounding cable of AWG 14 (2 mm²) or more between the grounding electrode and the grounding terminal of this product, and connect with the shortest route.
- Use a grounding cable of AWG 11 (4 mm²) or more and ring tongue terminal for M4 terminal between the grounding terminal of the arrester and grounding electrode, and connect with the shortest route via external grounding terminal of this product.
- Select the grounding cable that has a structure of adequately protects against mechanical damage, chemical or electrical degradation, electrodynamic force and thermodynamic force for connection of the grounding electrode and the ground terminal of this product or arrester.



IMPORTANT

The explosion proof compliant device always needs the grounding.

● Applicable Cable (Insulated wire for industrial equipment)

Examples:

- 600 V polyvinyl chloride insulated wires (IV): JIS C3307
- Polyvinyl chloride insulated wires for electrical apparatus (KIV): JIS C3316
- 600 V grade heat-resistant polyvinyl chloride insulated wires (HIV): JIS C3317
- Heatproof vinyl insulated wires VW-1 (UL1015/UL1007)

Wire size

- Core: AWG14 to 13 (2 to 2.6 mm²)

Terminal treatment

- Ring terminal for M4: With insulation covers

● **Connection of Cable**

Connect the grounding cable to the ground terminal of YFGW510.
The ground terminal is located at the bottom on the right side of the housing.

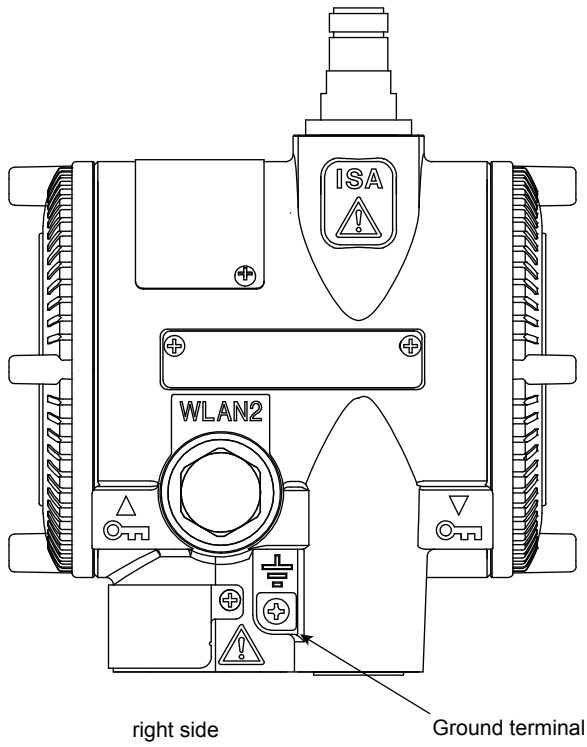

FC0502.ai

Figure C5-2 Connecting grounding cable

C5.3 Network Cable Connection

C5.3.1 Metal Network Cable Connection

- **Caution for use with metal network cable**

The metal network cable is intended for indoor wiring. In outdoor wiring, it is recommended the optical network cable in order to eliminate the influence of electromagnetic noise due to lightning and keep transmission distance. An optical fiber network cable is recommended if outdoor wiring is required because of transmission range and influence of electromagnetic noise due to lightning or other similar factors.

- **Cable**

Item	Specification
	Metal network cable
Standard	100BASE-TX
Connector	RJ-45 *
Cable	Category 5 or higher
Transmission range	100 m (Max.)

* RJ-45 connector attaching to the YFGW510-side end of the cable is larger than the cable gland hole. The RJ-45 does not go through the gland. Follow wiring procedures as described below.

- **Metal network cable connection procedure**

Connect the metal network cable using the following procedure.

1. Insert the metal network cable through the YFGW510 network cable gland. Be sure to use a 100BASE-TX cable.
2. Insert the cable through the communications connection and screw in the cable gland.
3. Crimp the RJ-45 connector to the end of the cable.
4. Connect the RJ-45 connector of the cable to the YFGW510.

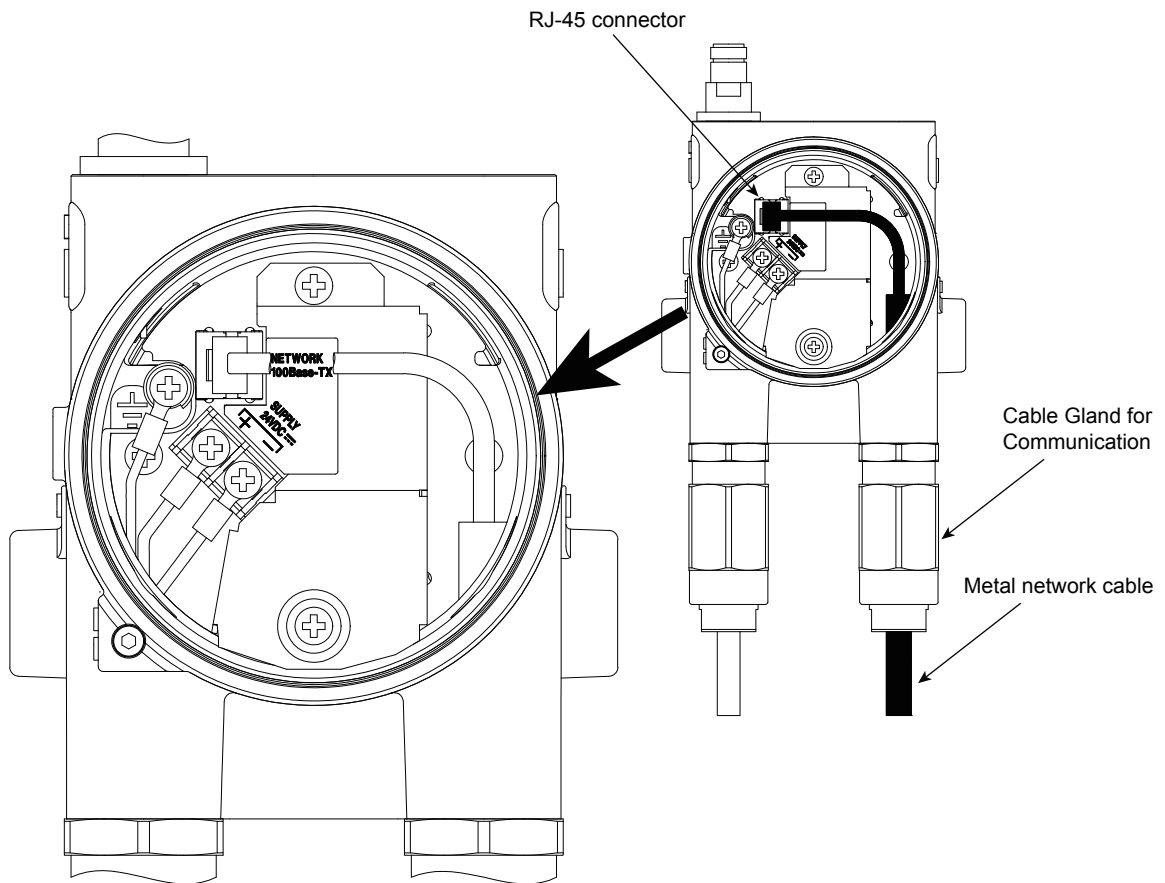

FC0503.ai

Figure C5-3 Connecting metal network cable

C5.3.2 Optical Network Cable Connection

● Cable

Item	Specification
	Optical network cable
Standard	100BASE-FX
Connector	SC connector (1-pole × 2)*
Cable	Multimode fiber (wavelength: 1300 nm) 50/125 μm or 62.5/125 μm The inner tension member must be nonmetal, such as FRP.
Transmission range	2 km (Max.)

* A double ferrule SC connector does not go through the connection hole. Be sure to use a short-boot SC connector.



IMPORTANT

To connect YFGW410 and YFGW510 using an optical network cable, the YFGW610 is required for YFGW410. YFGW610 is used for conversion between 100BASE-TX and 100BASE-FX.

● **Optical network cable connection procedure**

Connect the optical network cable in the following procedure.

1. Insert the optical network cable through the YFGW510 network cable gland.
2. Insert the connector through the YFGW510 connection and screw in the cable gland.
3. Connect the optical network cable to the SC connector of the device. Do not bend the optical network cable at a sharp angle.
4. The optical network cable consists of a pair of wires. One wire is used for sending signals and the other for receiving signals (TX/RX). The polarity of the YFGW510 SC connector is indicated on the connector label. If polarity is indicated on the optical network cable, follow the indication. If not, the wires can be connected to either port. The polarity can be easily changed on YFGW610.

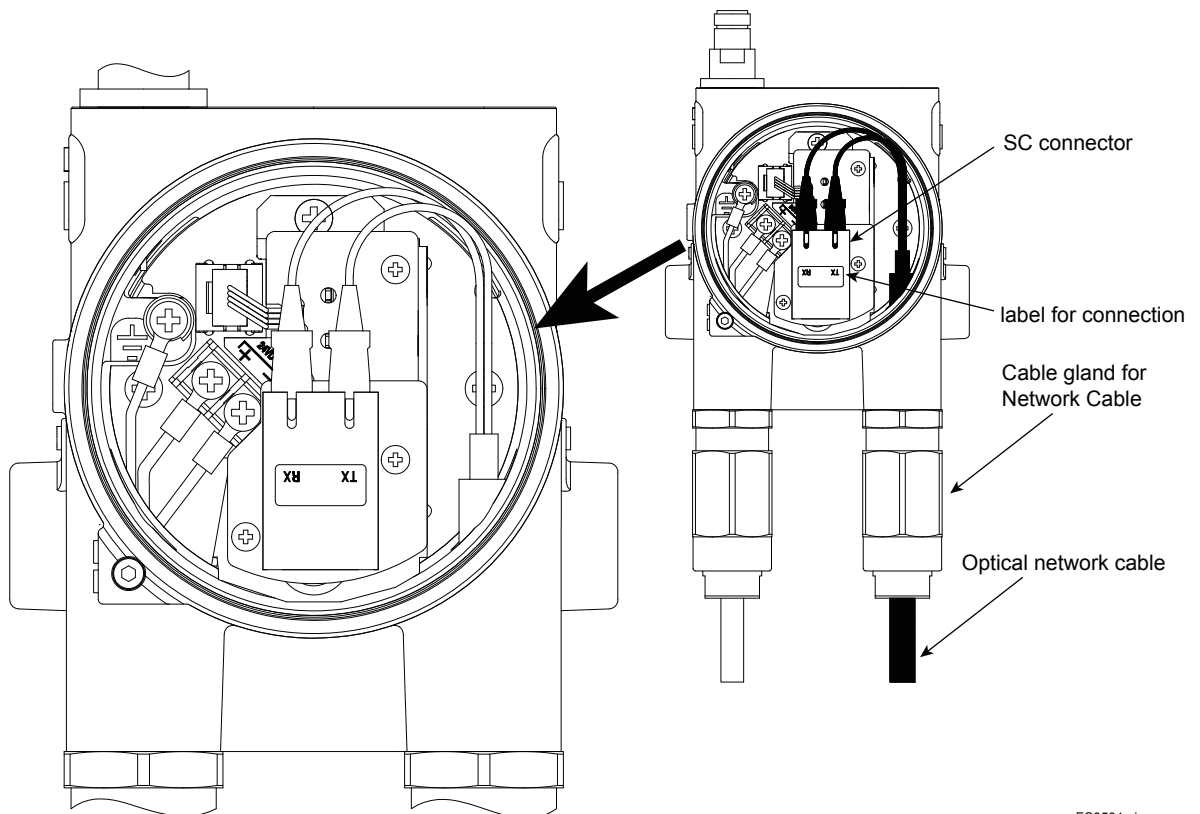

FC0504.ai

Figure C5-4 Connecting optical network cable

C5.4 Installation and Wiring of Antenna

This section describes mounting of antennas to YFGW510, and installation of remote antennas and their wiring.

C5.4.1 Mounting ISA100.11a Antenna to YFGW510

This section explains the procedure for mounting the ISA100.11a antenna directly into the connector on top of the device.

Screw the antenna into the antenna connector on the top of the device. Ensure that the antenna is properly mounted. Protect the connector with tape to increase resistance to environmental impact.

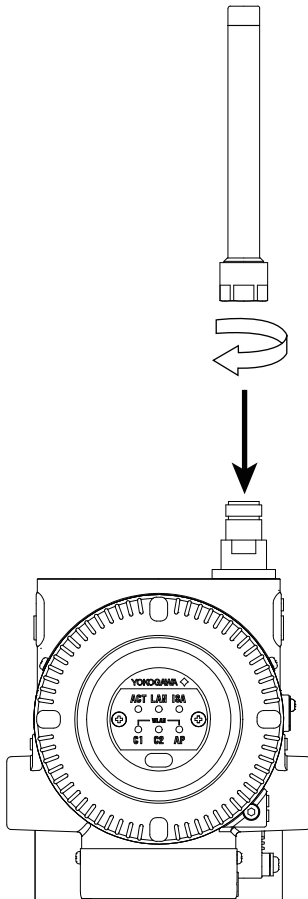

FC0505.ai

Figure C5-5 Mounting ISA100.11a antenna connector

● Antenna mounting procedure

1. Turn counter-clockwise the cover of the antenna connector on the top of YFGW510 to remove.
2. Mount the provided antenna into the antenna connector. Tighten the antenna connector with a torque of 2 to 3 N•m.
3. Protect the joint of the antenna and connector with tape.
 - Clean the connection to be protected.
 - Wind the butyl rubber self-bonding tape around the connection. See the manual of the tape about the winding.
 - To protect the butyl rubber self-bonding tape from the environment such as ultraviolet rays and so on, wind vinyl tape (or a vinyl type self-bonding tape) on it.

- **Tape**

- Butyl rubber self-bonding tape
- Vinyl tape or a vinyl type self-bonding tape

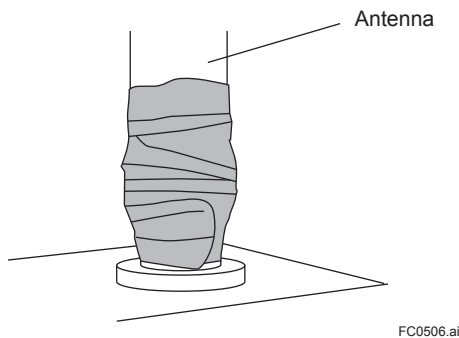

Figure C5-6 Sealing of antenna connector



IMPORTANT

The ISA100.11a antenna connector for the YFGW510 supports 2 dBi standard antennas only. A high-gain antenna, available as an optional accessory, must be installed as a remote antenna with an antenna extension cable, as described in the next section.

C5.4.2 Remote Installation and Wiring of ISA100.11a Antenna

This section explains the procedure for installing the ISA100.11a antenna away from YFGW510, using an antenna extension cable.

■ Installing the antenna

Install the antenna in an appropriate location for wireless communication, referring to C3.1 Requirements for Installation Locations. Make sure that the mounting of the antenna on a 2-inch pipe has enough strength to withstand strong winds and vibrations. The antenna must be kept upright.

- **Fastening the antenna**

Fasten the antenna to the pipe using the brackets provided with the antenna extension cable.

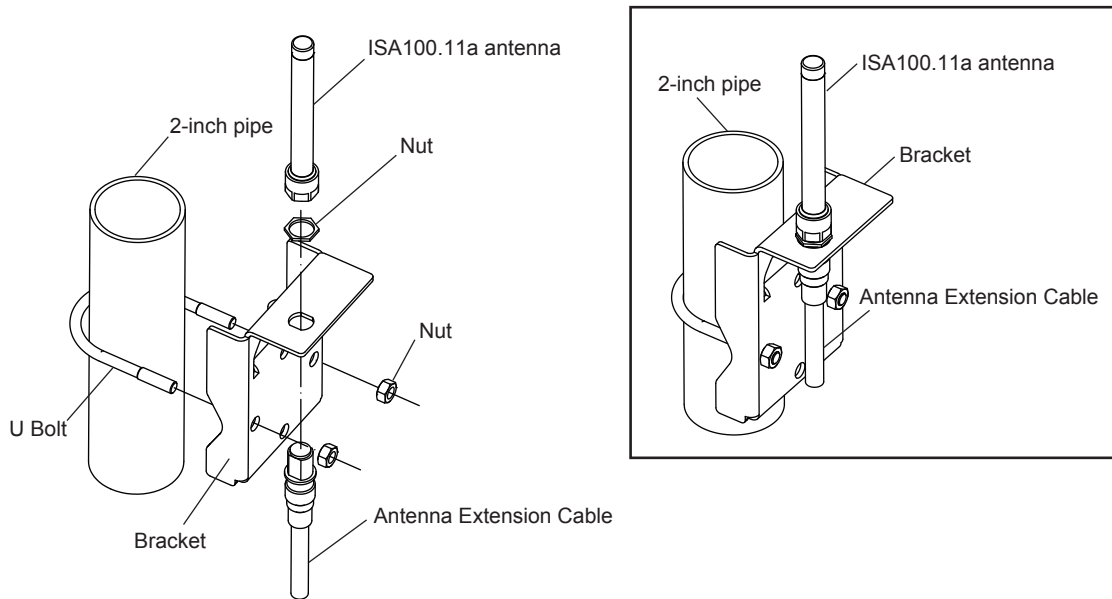

FC0507.ai

Figure C5-7 Fastening remote antenna

● **Mounting procedure of antenna**

1. Fix the bracket by U-bolt and nut to 2-inch pipe.
2. Fix the antenna extension cable to the bracket using the provided nut with a torque of 6 to 7 N·m as shown in the Figure C5-7. Use the nut which is attached to the antenna extension cable.
3. Screw the antenna into the antenna connector of the antenna extension cable on the bracket.
Tighten the antenna connector with a torque of 2 to 3 N·m.
4. Protect the connection with a tape as necessary. For details of the protection, see “C5.4.1 Mounting ISA100.11a antenna to YFGW510”.

■ **Antenna wiring and improvement of environment resistance**

● **Specification for antenna extension cable
(Only by order of option)**

- Specification: 8D-SFA(PE)
- Outside diameter: 11.1 mm
- Minimum bend radius: 67 mm (when fixing)
167 mm (when wiring)
- Cable end treatment: N type connector, one end is male and the other is female.

* “When fixing” shows the bending radius for fixing (the state is maintained for a long time). “When wiring” shows the bending radius while checking the wiring position. This bending radius is set larger than that for fixing in order to prevent damage to the cable because the cable is likely to be repeatedly bent when checking the final wiring position.

● **Wiring of antenna extension cable**

1. Use the provided antenna extension cable to connect the antenna connector with the remote antenna. Tighten the connector of the antenna extension cable with a torque of 2 to 3 N·m. Refer to the specification about the limitation of bend radius when fixing or wiring.
2. When using two antenna extension cables, the provided surge protective device should be inserted between these cables.
3. Before the wiring work, confirm the polarities (male/female) of the connectors of antenna, antenna extension cable, and surge protective device.
Tighten the connector of the antenna extension cable with a torque of 2 to 3 N·m.

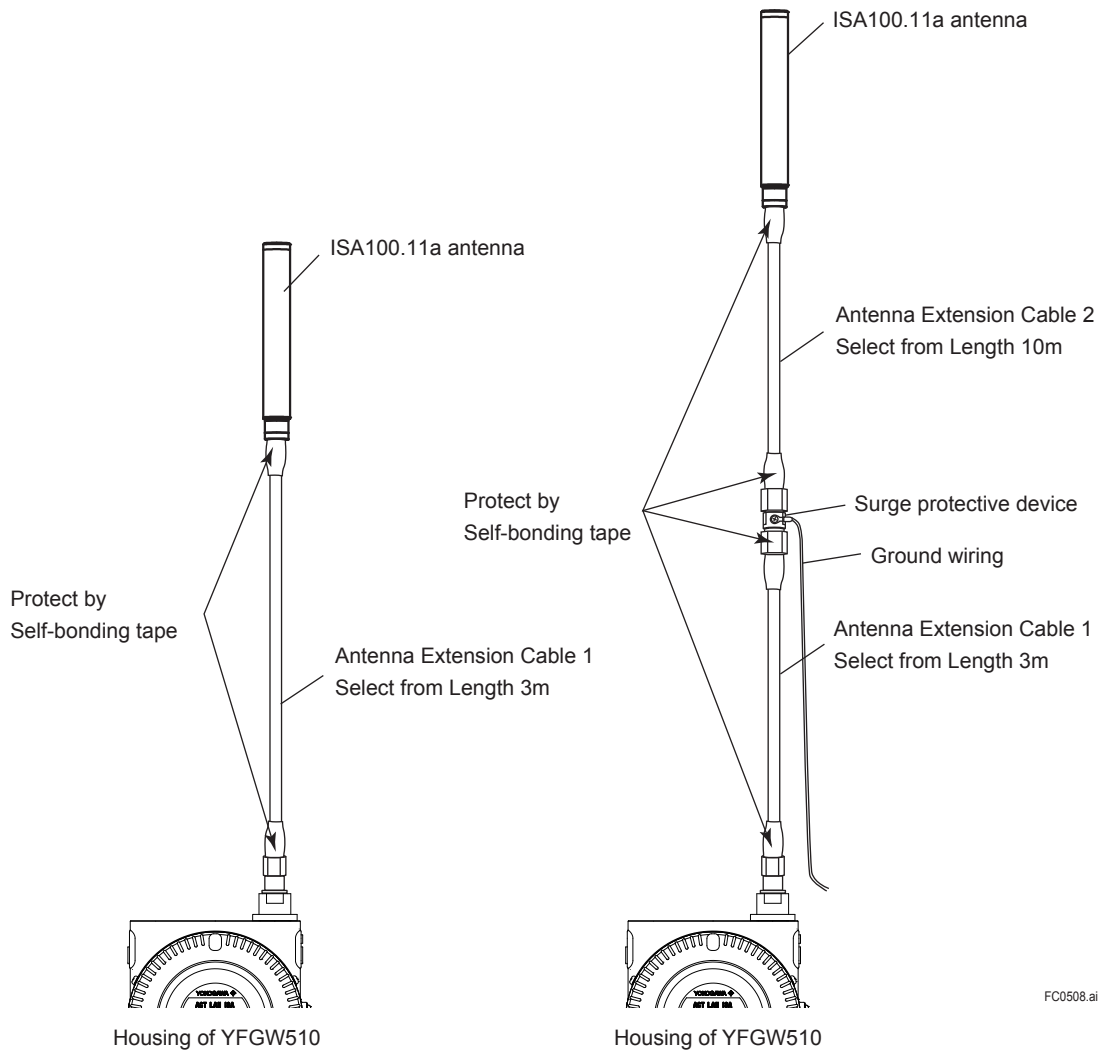

Figure C5-8 Wiring for remote antenna

● **Ground wiring of surge protective device for antenna extension cables**

To connect two antenna extension cables, an surge protective device for lightning protection is provided. Place the surge protective device between the two antenna extension cables. Connect the grounding cable to the ground terminal of the surge protective device.

Connect the grounding cable to the grounding terminal on the main body. Class D grounding (the third class grounding) with the grounding resistance of 100 Ω or less is necessary. Do not share the ground with other devices.

● **Grounding cable (Insulated for industrial equipment)**

Examples

- 600 V polyvinyl chloride insulated wires (IV): JIS C3307
- Polyvinyl chloride insulated wires for electrical apparatus (KIV): JIS C3316
- 600 V grade heat-resistant polyvinyl chloride insulated wires (HIV): JIS C3317
- Heatproof vinyl insulated wires VW-1 (UL1015/UL1007)

Wire size

- Core: AWA14 to 13 (2 to 2.6 mm²)

Terminal treatment

- Ring terminal for M4: With insulation covers

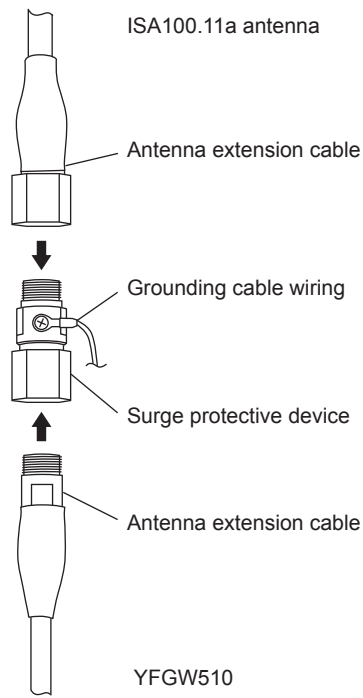

FC0509.ai

Figure C5-9 Wiring for surge protective device

- **Waterproofing antenna cables and connectors**

Make sure that the antenna, antenna extension cables and surge protective device wiring including the grounding cable are connected properly. Protect the connectors and the surge protective device with tape. As described in C5.4.1 Mounting ISA100.11a Antenna to YFGW510, wind self-bonding tape and vinyl tape around connections.

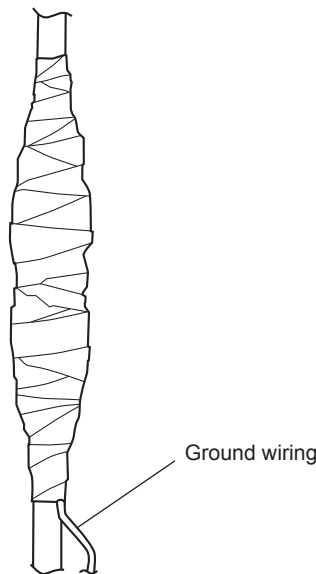

FC0510.ai

Figure C5-10 Sealing antenna wiring

- **Fastening antenna wiring**

After taping, fasten the cables to a solid structure to protect against vibration and wind. Ensure that the radii of bends in the cables do not fall below the limits above.

C5.4.3 Installation and Wiring of Wireless LAN Antenna

The wireless LAN antenna must be connected to YFGW510 using an antenna extension cable in order to prevent interference with the ISA100.11a antenna and to mount the antenna vertically. To fasten the antenna, use the brackets provided with the antenna extension cable.

Basically, the wireless LAN antenna must be at least 1 m away from the ISA100.11a antenna. In a wireless LAN redundant model, the wireless LAN antennas must be at least 1m away from each other. When wireless LAN antennas or the ISA100.11a antenna is located near a mounting pipe or any other metal object, allow clearance of at least 30 cm.

■ Installing wireless LAN antennas

Install the wireless LAN antenna in an appropriate location for wireless communication, referring to requirements on distance from the ISA100.11a antenna, and C3.1 Requirements for Installation Locations. Make sure that the mounting of the antenna on a 2-inch pipe has enough strength to withstand strong winds and vibration. The antenna must be kept upright.

- **Fastening wireless LAN antenna**

Fasten the wireless LAN antenna to the pipe using the brackets provided with the antenna. When mounting on a vertical pipe, make sure that the antenna stands higher than the top of the pipe.

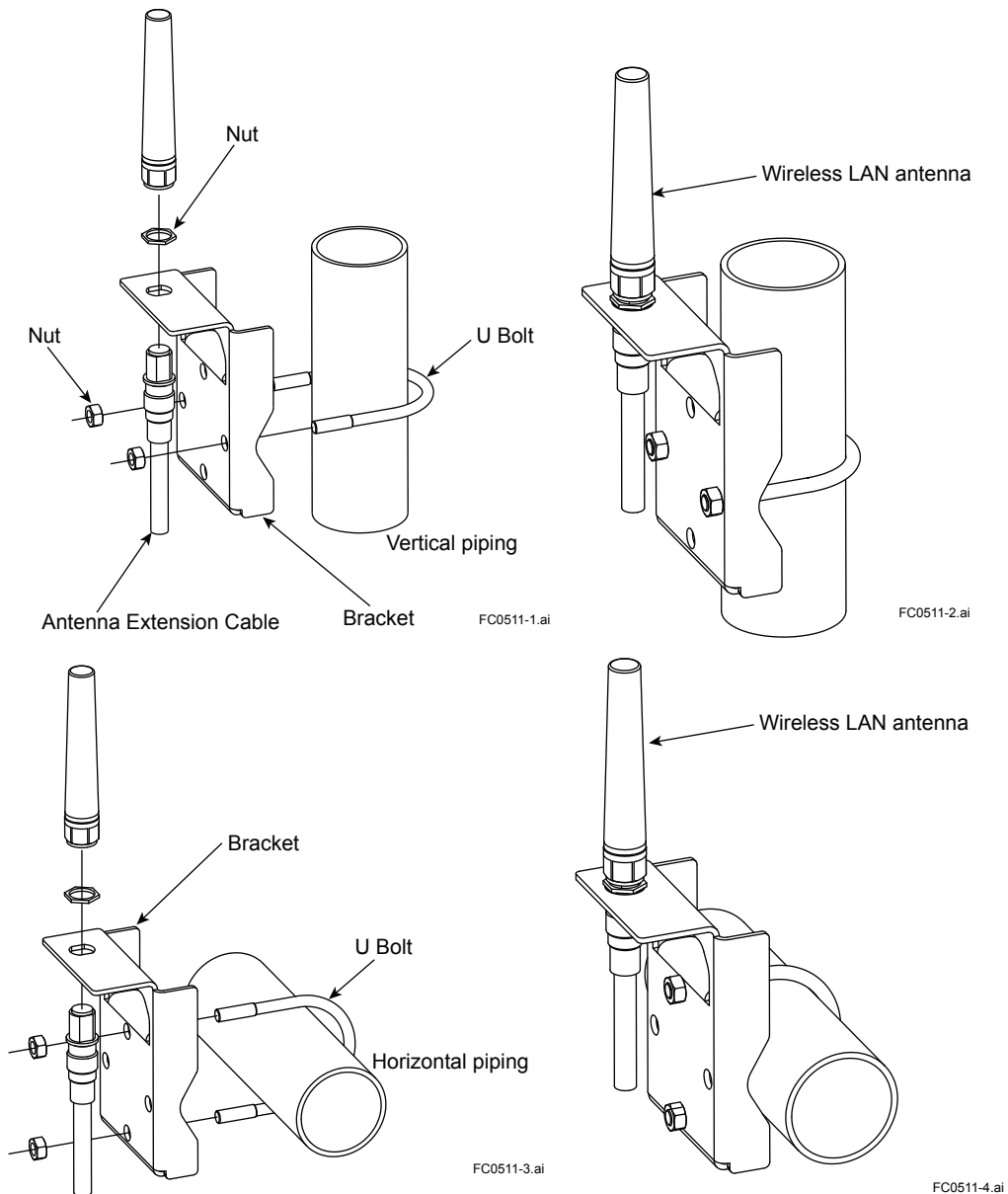

Figure C5-11 Fastening wireless LAN antenna

● **Wireless LAN antenna fastening procedure**

1. Fix the bracket by U-bolt and nut to 2-inch pipe.
2. Fix the antenna extension cable to the bracket using the provided nut with a torque of 6 to 7 N·m as shown in the Figure C5-11. Use the nut which is attached to the antenna extension cable.1
3. Screw the antenna into the antenna connector of the antenna extension cable on the bracket.
Tighten the antenna connector with a torque of 2 to 3 N·m.
4. Protect the connection with a tape as necessary. For details of the protection, see “5.4.1 Mounting ISA100.11a antenna to YFGW510”.

■ Wiring of wireless LAN antenna and improvement of environmental resistance

● Specification of extension cable for wireless LAN antenna (Use only the cables included as option.)

- Specification: 8D-SFA(PE)
 - Outside Diameter: 11.1 mm
 - Minimum Bend Radius: 67 mm (when fixing)
167 mm (when wiring)
 - Cable End Treatment: N type connector, one end is male and the other is female.
- * “When fixing” shows the bending radius for fixing (the state is maintained for a long time). “When wiring” shows the bending radius while checking the wiring position. This bending radius is set larger than that for fixing in order to prevent damage to the cable because the cable is likely to be repeatedly bent when checking the final wiring position.

● Wiring procedure of wireless LAN antenna

1. Use the provided antenna extension cable to connect the antenna connector with the remote antenna. Tighten the connector of the antenna extension cable with a torque of 2 to 3 N·m. Refer to the specification about the limitation of bend radius when fixing or wiring.
2. When using two antenna extension cables, the provided surge protective device should be inserted between these cables.
3. Before the wiring work, confirm the polarities (male/female) of the connectors of antenna, antenna extension cable, and surge protective device. Tighten the connector of the antenna extension cable with a torque of 2 to 3 N·m.

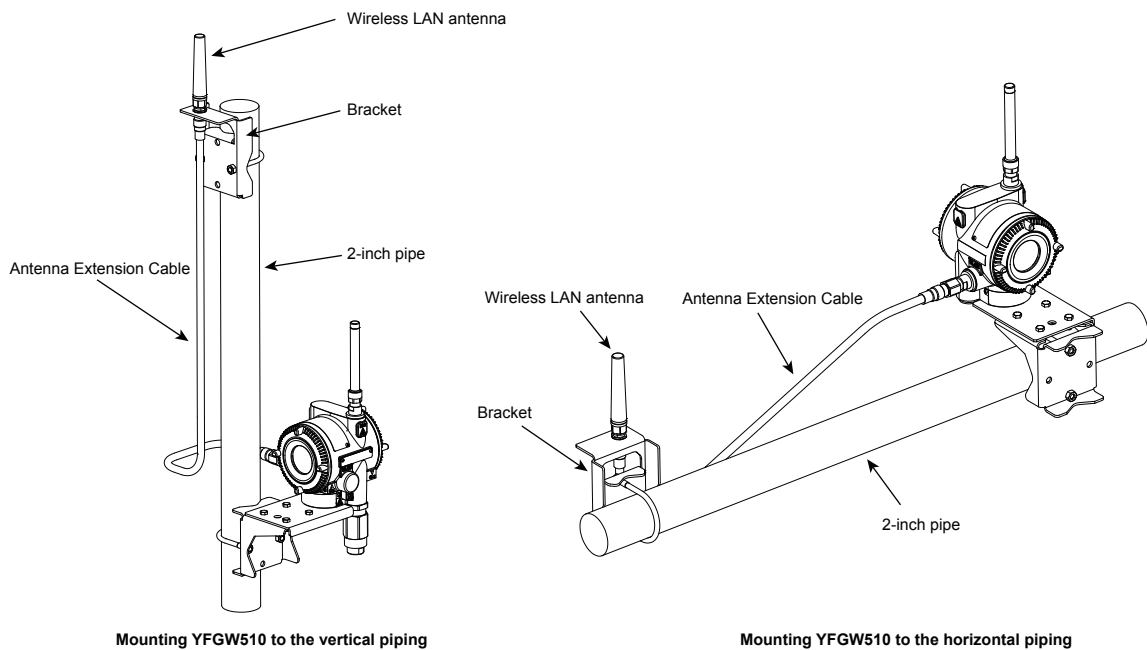
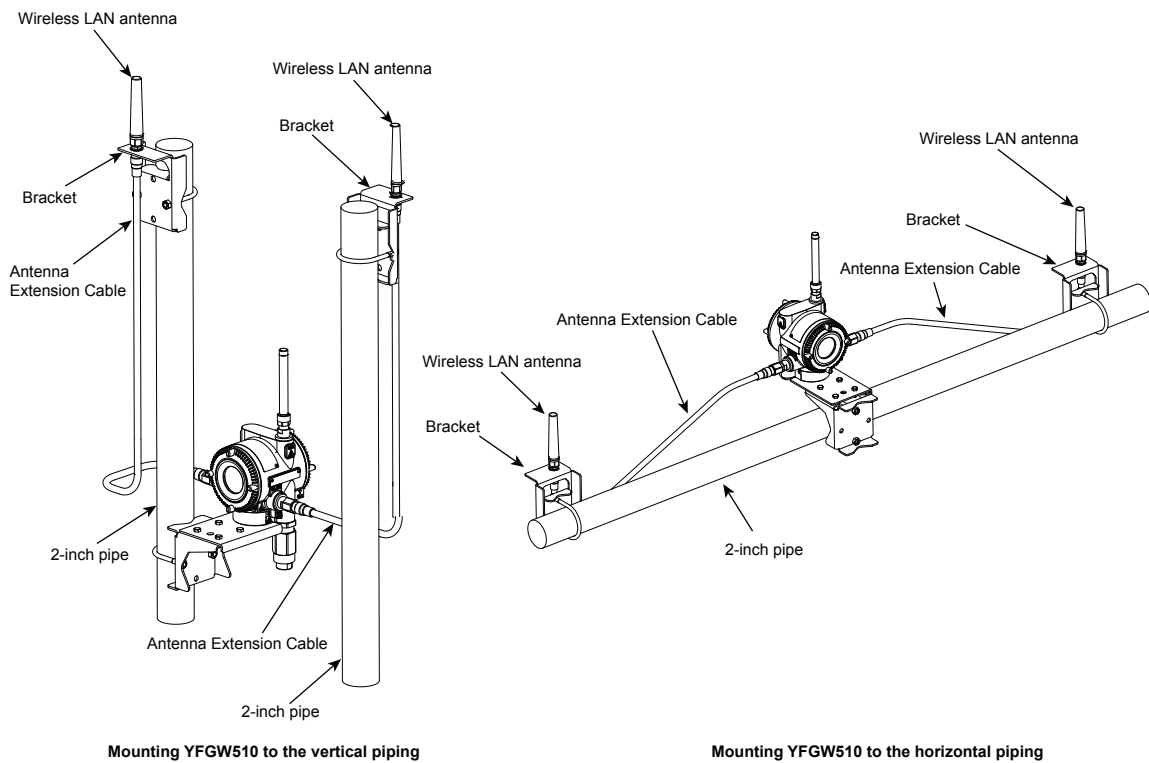

Figure C5-12 Wiring of wireless LAN antenna (wireless LAN single model)

FC0512.ai



FC0513.ai

Figure C5-13 Wiring of wireless LAN antenna (wireless LAN redundant model)

● **Ground wiring of surge protective device**

Place a surge protective device between two antenna extension cables. Connect the grounding cable to the ground terminal of the surge protective device.

Connect the grounding cable to the ground terminal on the main body. Class D grounding (the third class grounding) with the grounding resistance of 100 Ω or less is necessary. Do not share the ground with other devices.

● **Grounding cable (Insulated for industrial equipment)**

Examples

- 600 V polyvinyl chloride insulated wires (IV): JIS C3307
- Polyvinyl chloride insulated wires for electrical apparatus (KIV): JIS C3316
- 600 V grade heat-resistant polyvinyl chloride insulated wires (HIV): JIS C3317
- Heatproof vinyl insulated wires VW-1 (UL1015/UL1007)

Wire size

- Core: AWG14 to 13 (2 to 2.6 mm²)

Terminal treatment

- Ring terminal for M4: With insulation covers

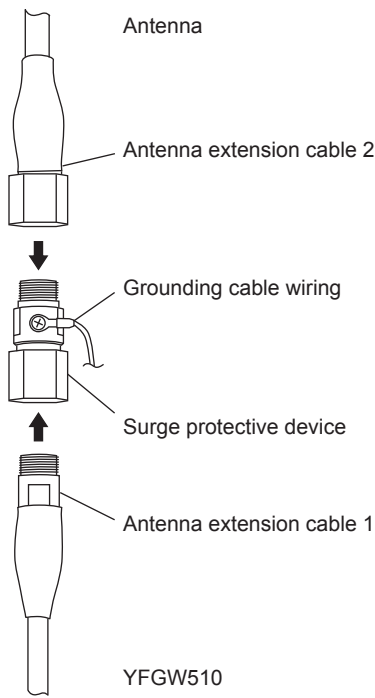

FC0514.ai

Figure C5-14 Wiring for surge protective device

● **Waterproofing antenna extension cables and connectors**

Make sure that the antenna, antenna extension cables and surge protective device wiring including the grounding cable are connected properly. Protect the connectors and the surge protective device with tape. As described in C5.4.1 Mounting ISA100.11a Antenna to YFGW510, wind self-bonding tape and vinyl tape around connections.

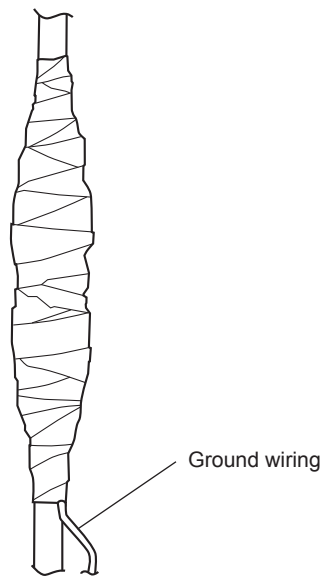

FC0515.ai

Figure C5-15 Sealing for antenna wiring

● **Fastening wireless LAN antenna wiring**

After taping, fasten the cables to a solid structure to protect against vibration and wind. Ensure that the radii of bends in the cables do not fall below the limits above.

C6. Explosion Proof Wiring

Be sure to read the precautions for the explosion protected type product including wiring described in “YFGW510 Field Wireless Access Point Read Me First (IM 01W02E01-11EN)”.

PART-D. SETUP

D1. Initial Configuration

Initial configuration is required to connect YFGW510 to YFGW410.

To set the initial configuration, install the Field Wireless Access Point Setup Tool (hereafter simply referred to as Setup Tool) provided with YFGW510 on a PC and connect the infrared adapter of the PC to YFGW510.

The table below shows the essential items to set in the initial configuration.

Setting item	Description	Scope
Device tag	The device tag of YFGW510	All models
Password to YFGW410	Password to connect to YFGW410	
Login password	Password to log in to the field wireless access point setup tool	
SSID1	Identification code of the wireless LAN	Wireless LAN client model
Encryption 1	Encryption method	
Network key 1	Initial encryption key	
Band 1	Frequency band of the wireless LAN	
Channel 1	Channel of the wireless LAN	
Data rate 1	Communications rate of the wireless LAN	Wireless LAN redundant model
SSID2	Identification code of the wireless LAN	
Encryption 2	Encryption method	
Network key 2	Initial encryption key	
Band 2	Frequency band of the wireless LAN	
Channel 2	Channel of the wireless LAN	
Data rate 2	Communications rate of the wireless LAN	

Note: The default settings are provided in the descriptions below.

D2. Setup Tool

This chapter provides system requirements and installation procedures for the Setup Tool.

D2.1 System Requirements

- Basic license of software provided with YFGW510: 1 license
- Language: English

D2.1.1 Hardware

- Recommended system requirements of PC

Item	System requirements
CPU	Intel Core i5-2520M or equivalent, or higher
RAM	2 GB minimum
Hard disk	40 GB minimum (at least 15 GB free space)
Display	Color: True Color (32 bits or more) Resolution: 1280 x 800 or higher
Communications device	Ethernet network card USB 2.0 port

- Infrared adapter

The following infrared adapter is recommended for this field wireless access point setup tool. The adapter is not provided with YFGW510 or setup tool. The infrared adapter is available as an extra option.

Item	System requirements
Manufacturer	ACTISYS
Product name	IR224UN
Model No.	ACT-IR224UN-LN96-LE
Baud rate	9600 bps

D2.1.2 Software

- Software requirements

Supported OS ^{*1,2}	Type
Windows10 Pro ^{*3}	32/64 bit
Windows8.1 Pro Update ^{*4}	32/64 bit
Windows7 Professional Service Pack 1 ^{*4}	32/64 bit
Windows Server 2012 R2 Standard Update ^{*4}	64 bit
Windows Server 2008 R2 Enterprise Service Pack 1 ^{*4}	64 bit
Windows Server 2008 Enterprise Service Pack 2 ^{*4}	32 bit

*1: Japanese or English version is supported.

*2: The 64-bit operating systems run on WOW64 (Windows 32-bit On Windows 64-bit).

*3: Microsoft .NET Framework 4.6 is required.

*4: Microsoft .NET Framework 4.5.2 is required.

D2.1.3 Connection Example

To use the setup tool, infrared communication between the PC and YFGW510 is required. Connect the infrared adapter to a USB port on the PC. Place the infrared adapter close to the infrared port of YFGW510 and ensure that they face each other. For distance between YFGW510 and the infrared adapter, see the table below.

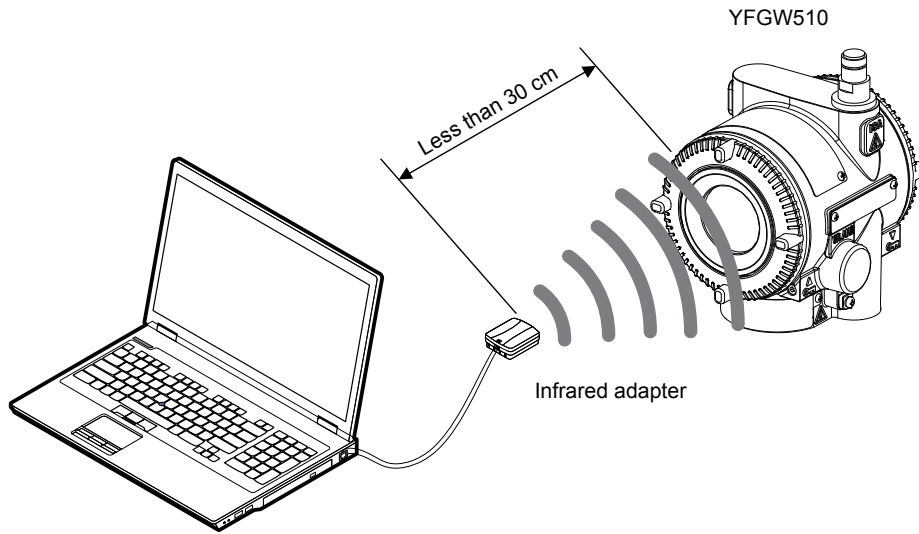

Field wireless access point setup tool

FD0201.ai

Figure D2-1 Connection example for field wireless access point setup tool

Table D2-4 Communications distance between YFGW510 and the infrared adapter

Item	Communications distance
Recommended communications distance	Within 20 cm
Maximum communications distance	30 cm

D2.2 Installation Procedure

Install the Setup Tool and an infrared adapter driver on the PC.

D2.2.1 Driver for Infrared Adapter

- **Installing the driver**

Install the driver by the media provided with the infrared adapter, referring to the user’s manual of ACTiSYS.

- **Checking the device**

Connect the infrared adapter to a USB port on the PC. Check the Device Manager to see whether the PC has detected the infrared adapter. To display the Device Manager, select Control Panel on the menu, select Hardware and Sound, then Device Manager. The window, as shown in Figure D2-2, will appear.

When the PC has detected the infrared adapter, Prolific USB-to-Serial Comm Port(COMx) will appear under COM port. The letter “x” represents the COM port number. Write down this number. The COM port number assigned to the infrared adapter is needed at the start of setup. In the example shown in Figure D2-2, the adapter is assigned to COM9.

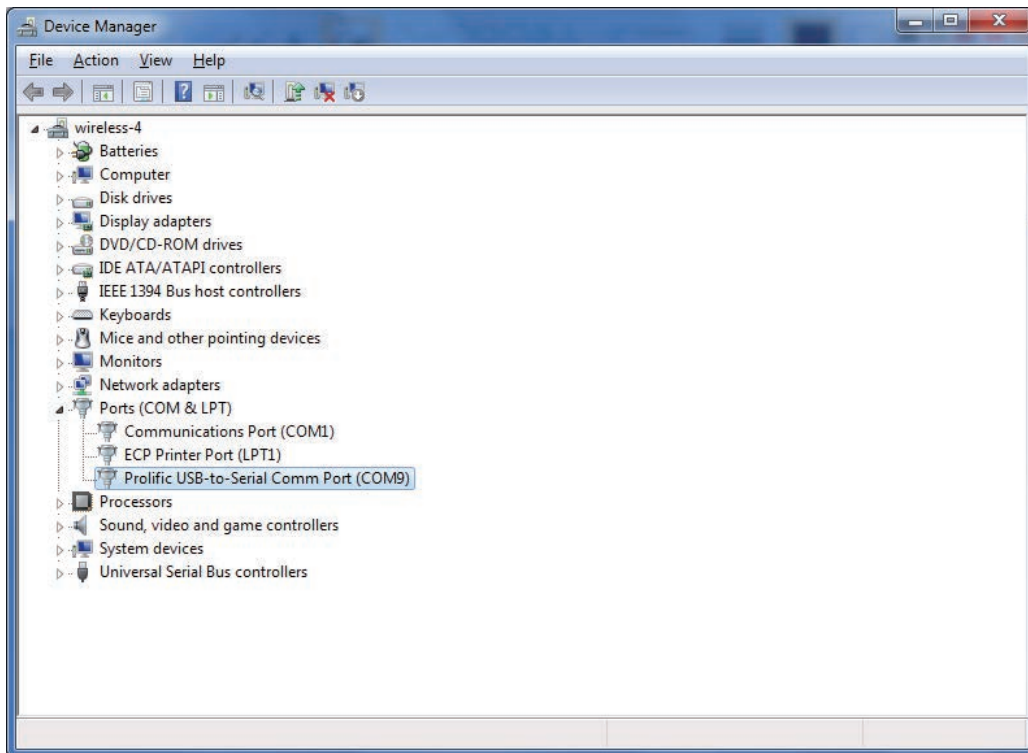

FD0202.ai

Figure D2-2 Example of Device Manager window

D2.2.2 Field Wireless Access Point Setup Tool

● Installation

Insert the DVD, provided with YFGW510, into the PC. Copy the folder containing the Setup Tool (YFGW510Tool.exe and FWMCCCommon.dll) into a folder on the PC hard drive. This program will not change the registry information of Windows.

● Starting the Setup Tool

Double-click the YFGW510Tool.exe icon to start the tool.

When the program has started, the login window, as shown in Figure D2-3, appears and prompts you to enter the COM port number of the infrared adapter and the password to log in to YFGW510.



IMPORTANT

When using the Setup Tool, must quit FieldMate, Provisioning Device Tool, and the other application that connected to the infrared adapter.

In after, communication between the PC running the tool and YFGW510 must be kept available via the infrared adapter.



IMPORTANT

When using the Setup Tool, YFGW510 must completes bootup sequence.

A booting up time of YFGW510 from power-on is depended on models as follows.

- 100BASE-TX/100BASE-FX model: 10 seconds
- Wireless LAN Client models: 30 seconds

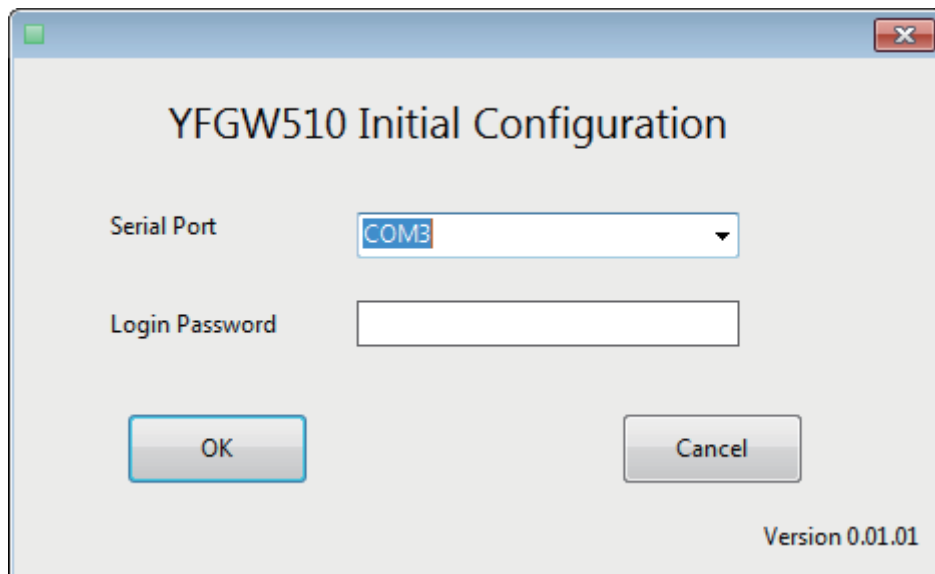

FD0203.ai

Figure D2-3 Login window

The table below shows the setting items and their default settings.

Item	Number of characters	Default setting
Serial Port	The number of the port the infrared adapter is connected to	The smallest COM number among those devices
Login Password	Up to 8 one-byte alphanumeric characters or other symbols (e.g., !,\$,#)	yokogawa

In the Serial Port field, enter the COM port number of the infrared adapter. Open the pull-down list, then select the COM port number to which the infrared adapter is connected.

When beginning the program for the first time, enter the default login password in the Login Password field.

Click the [OK] button. The Change Login Password window as shown in Figure D2-5 will appear if the Setup Tool is communicating with YFGW510.

Click the [Cancel] button to exit the setup tool. The window will close.



IMPORTANT

- If the wrong password is entered three times straight, YFGW510 will not accept another login attempt for 30 minutes. Type in the password carefully.
- Keep the login password safe. It is necessary for setting up the YFGW510.

After clicking the [OK] button, if there is a problem in communication between the Setup Tool and YFGW510, the error dialog as shown in Figure D2-4 will appear.

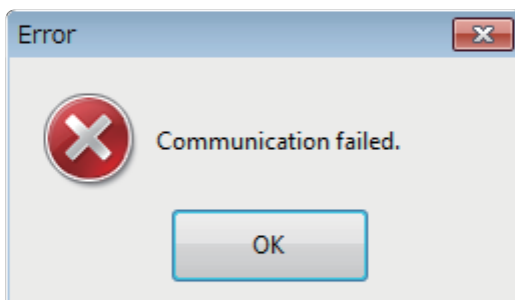

FD0204.ai

Figure D2-4 Communication Error Dialog

Check the adapter COM port number, and positions in the front window of YFGW510.

After the problem has been solved, click the [OK] button. The window will close.

Go back to the window as shown in Figure D2-3. Check the entered information and click the [OK] button to proceed.

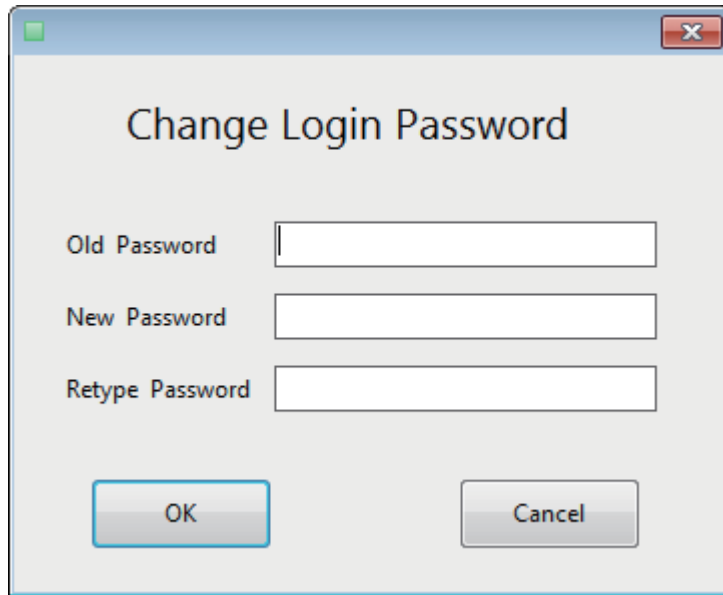

FD0205.ai

Figure D2-5 Change Login Password window

Change the default login password to a new password to ensure security. Enter the current password (default) in the Old Password field, then type a new password in the New Password and Retype Password fields.

Click the [OK] button. When the password has been successfully changed, the main window as shown in Figure D2-6 will appear.

Click the [Cancel] button to exit the program. All windows will close.

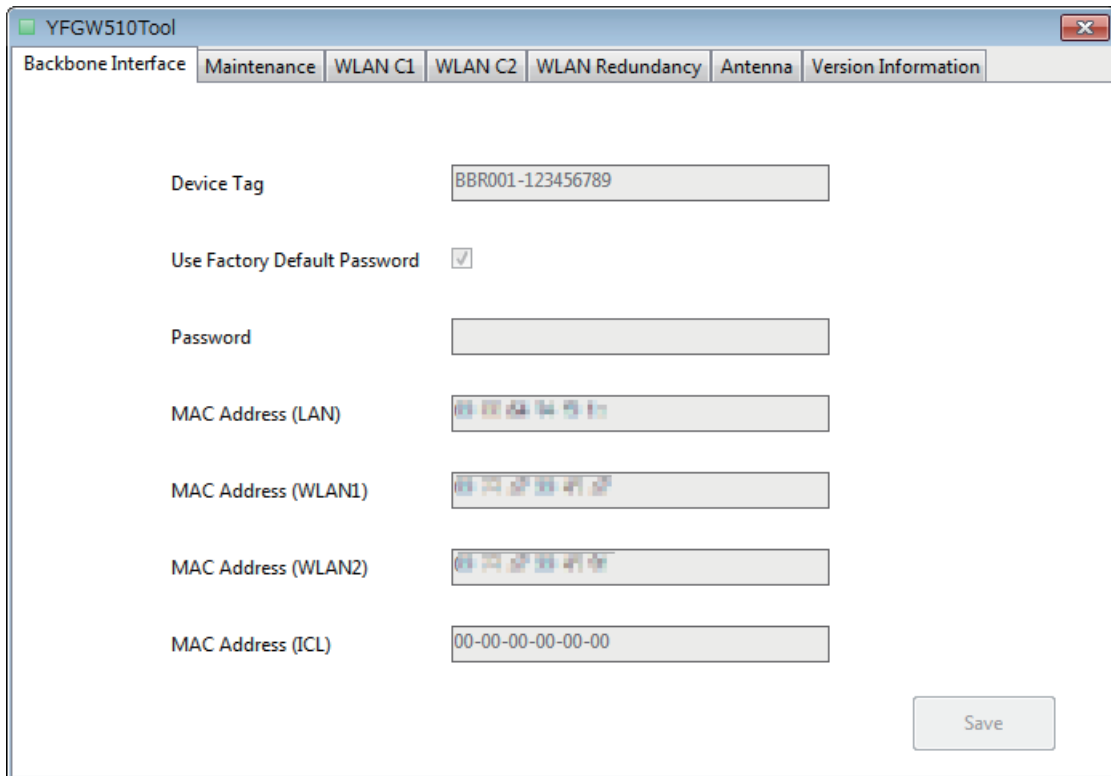

FD0206.ai

Figure D2-6 Main window

The Backbone Interface tab of the window is always shown at startup of the setup tool.



IMPORTANT

If YFGW510 is factory default, the setup tool starts in Edit mode.

Otherwise, the setup tool starts in Display mode and each field and button is grayed out.

- **Problem with infrared communications**

If, after login to YFGW510, an infrared communication failure occurs, the communication error window shown in Figure D2-4 appears similarly when an error occurs during login to Configuration tool.

After verifying and fixing the problem, click the [OK] button to close the window. In this case, retry to log in again.

- **Setup tool operation timeout**

If there is no operation for five minutes during the configuration of the Setup Tool indicate a time-out error shown in Figure D2-7, will appear on top of the main window. In this case, retry to log in again.

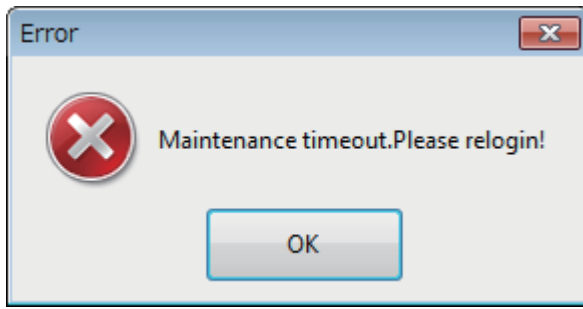

FD0207.ai

Figure D2-7 Timeout Error Dialog

D3. Configuration Method

This chapter describes initial configuration of YFGW510 using the Setup Tool.

D3.1 Window Design

The main window of the Setup Tool consists of the following seven tabs.

The following table shows the summary of the setting functions of each tab.

Tab Name	Functions
Backbone Interface	Setting of a device tag and password for YFGW410 connection
Maintenance	Display/Edit mode switching, restart and login password modification
WLAN C1	Setting of wireless LAN 1
WLAN C2	Setting of wireless LAN 2
WLAN Redundancy	Setting of wireless LAN redundant communication
Antenna	Maintenance use only. The tab cannot be opened.
Version Information	Viewing of the version information

D3.2 Display/Edit Mode Switching

The Setup Tool has two operation modes: Display, to view the setting information, and Edit, to configure YFGW510. The Setup Tool always starts up in Display mode. To allow for YFGW510 configuration, the mode needs to be switched to Edit.



IMPORTANT

If YFGW510 is factory default, the setup tool starts in Edit mode.

Otherwise, the setup tool starts in Display mode and each field and button is grayed out.



IMPORTANT

If switching Display/Edit Mode, YFGW510 will restart.



IMPORTANT

In Edit mode, only infrared communication is available.

To change modes, select the [Maintenance] tab as shown in Figure D3-1.

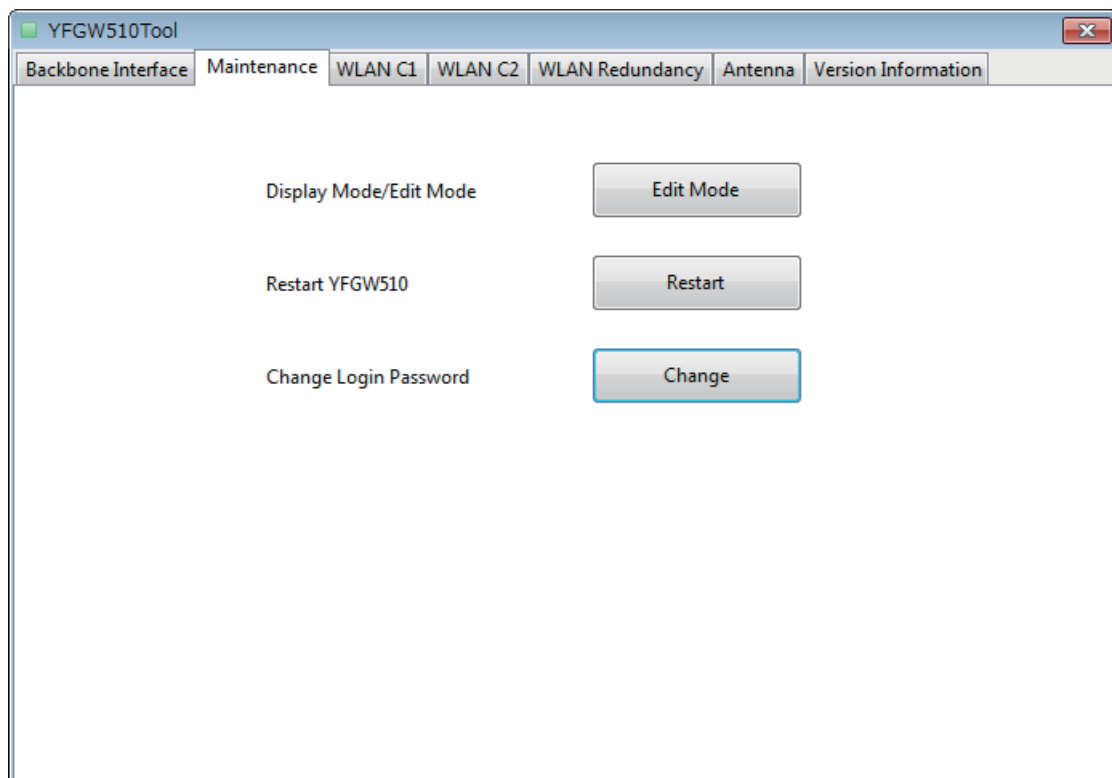

FD0301.ai

Figure D3-1 Maintenance tab

Click the button in the [Display Mode/Edit Mode] field to select the target mode.

If the button shows “Edit Mode”, a current mode is Display. Otherwise, a current mode is Edit.

Clicking the [Edit Mode] button displays a confirmation dialog as shown in Figure D3-2.

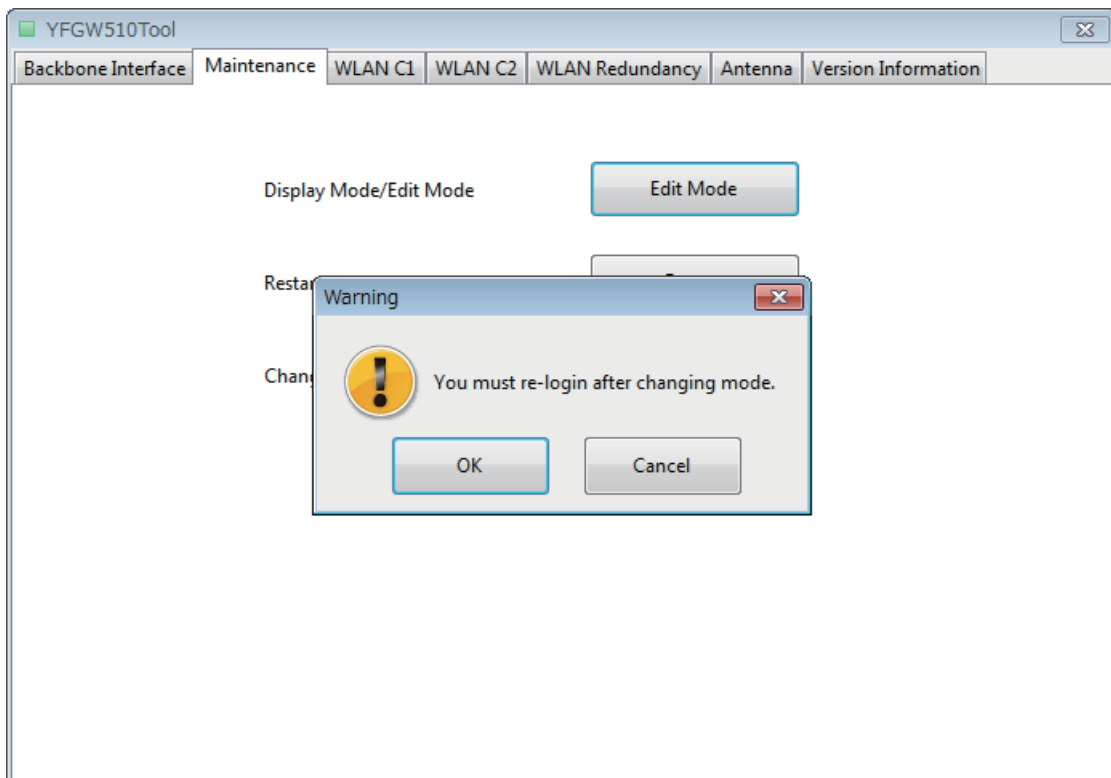

FD0302.ai

Figure D3-2 Mode Change Confirmation Dialog

Clicking the [OK] button navigates to the login window shown in Figure D2-3. Log in again and setup will start up in Edit mode.

Clicking the [Cancel] button terminates the mode switching.

Setup starts up in Display mode even if the mode was Edit at the last logoff; so, it is necessary to change modes every time the YFGW510 setting modification is required.

If configuration have been completed, restart the YFGW510 click the [Restart] button.

For other button functions, see D3.4 Maintenance.



IMPORTANT

Changing mode requires that YFGW510 completes bootup sequence.

If changing mode is failed, restart the YFGW510. For details of a booting up time of YFGW510, see D2.2.2 Field Wireless Access Point Setup Tool.

D3.3 Backbone Interface

The [Backbone Interface] tab allows a change in settings for the YFGW510 connection to the field wireless backbone network. Figure D3-3 shows the [Backbone Interface] tab in Edit mode.

The screenshot shows the 'YFGW510Tool' application window with the 'Backbone Interface' tab selected. The window contains several configuration fields:

- Device Tag:** A text input field containing 'BBR001-123456789'.
- Use Factory Default Password:** A checkbox that is checked.
- Password:** An empty text input field.
- MAC Address (LAN):** A text input field with a hexadecimal MAC address.
- MAC Address (WLAN1):** A text input field with a hexadecimal MAC address.
- MAC Address (WLAN2):** A text input field with a hexadecimal MAC address.
- MAC Address (ICL):** A text input field containing '00-00-00-00-00-00'.

A 'Save' button is located at the bottom right of the window.

FD0303.ai

Figure D3-3 Backbone Interface tab

The following are items that need to be set in YFGW510.

Item	Descriptions	Initial Value
Device Tag	Enter the YFGW510 device tag.	Blank
Use Factory Default Password	Select whether to use the factory default password for the connection to YFGW410. If checked, the factory default password will be used.	Checked
Password	If the [Use Factory Default Password] checkbox is not selected (the default password is not used), enter any password.	Blank

● Device tag setting regulation

The device tag for the YFGW510 has the following restrictions. No string outside of these restrictions can be accepted.

- Up to sixteen characters
- Alphanumeric characters, hyphens and underscores only
- Single-byte, uppercase only

● **Password setting regulation**

The password for the connection to YFGW410 on the YFGW510 has the following restrictions. No string outside of these restrictions can be accepted.

- Up to sixteen characters
- From “A” to “F” and numeric characters only (case sensitive)

After entering all required items, click the [Save] button to store settings in YFGW510.

The following is information about YFGW510. No setting is required.

Items	Descriptions
MAC Address (LAN)	Wired LAN MAC address
MAC Address (WLAN1)	Wireless LAN 1 MAC address
MAC Address (WLAN2)	Wireless LAN 2 MAC address
MAC Address (ICL)	00-00-00-00-00-00 fixed

D3.4 Maintenance

Clicking the [Maintenance] tab displays the controls shown in Figure D3-4.

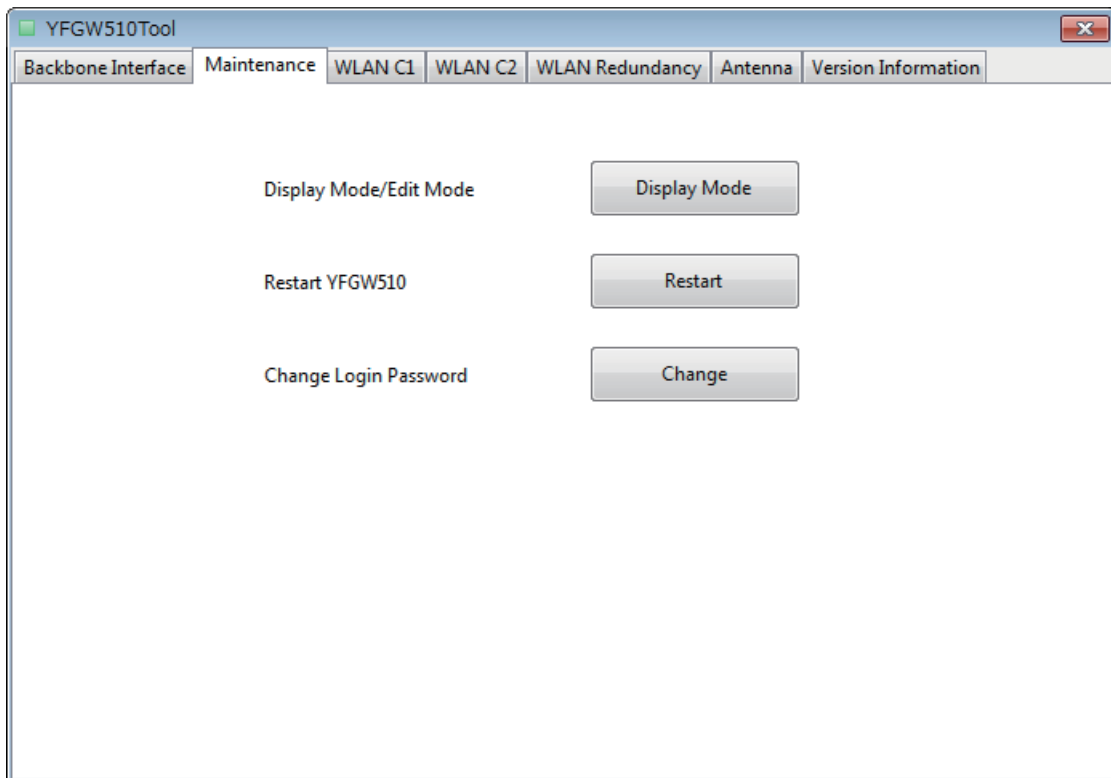

FD0304.ai

Figure D3-4

The following describes the functions of the buttons on this tab.

Button Name	Function
Display Mode/Edit Mode	Clicking the button switches Display/Edit mode for the Setup Tool. For details, see D3.2 Display/Edit Mode Switching.
Restart YFGW510	Clicking the button restarts YFGW510.
Change Login Password	This button allows the modification of the YFGW510 login password. Clicking the button displays the window shown in Figure D2-5. For details, see Field Wireless Access Point Setup Tool in D2.2.2.

Clicking the [Restart] button displays a confirmation dialog box as shown in Figure D3-5.

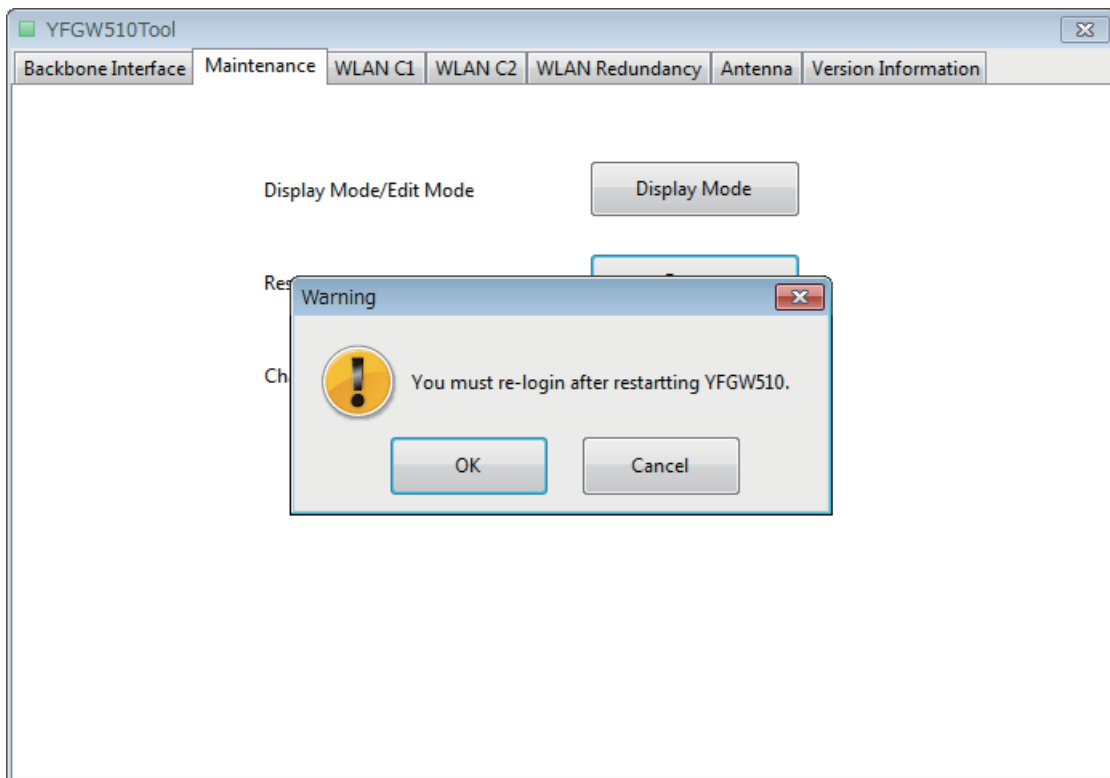

FD0305.ai

Figure D3-5 YFGW510 Restart Confirmation Dialog

Clicking the [OK] button restarts YFGW510 and navigates to the login window shown in Figure D2-3.

Clicking the [Cancel] button terminates the process and closes the confirmation dialog.

D3.5 Setting of Wireless LAN 1 (WLAN C1)

Clicking the [WLAN C1] tab displays the controls and information shown in Figure D3-6.

FD0306.ai

Figure D3-6 WLAN C1 tab

This tab allows the setting of wireless LAN 1.

The setting items are as follows.

Item	Descriptions	Initial Value
SSID	Wireless LAN identification code. Enter the same value as the SSID of wireless LAN access point being connected. For details, see SSID setting.	Blank
Security	Display-only, security method	WPA2-PSK
Encryption	Display-only, encryption method	AES
Network Key	Encryption key. Enter the same value as the encryption key of wireless LAN access point being connected. For details, see Network key setting.	Blank
Band	Wireless LAN frequency band. Select either 2.4 GHz or 5 GHz.	"2.4 GHz"
Channel	Wireless LAN channel. Select the channel to be used in wireless LAN. The selectable channels vary depending on the frequency band. For details, see Band and channel setting regulation.	"Auto"
Data Rate	Wireless LAN communication data rate. Select the data rate of wireless LAN. The selectable data rates vary depending on the frequency band. For details, see Data rate setting regulation.	"Auto"



IMPORTANT

Usable wireless channels are regulated by radio standards.

Please confirm that a installation region fulfills the standards before use.

● **SSID setting**

The SSID for the YFGW510 has the following restrictions:

- Up to 31 characters
- Single-byte, alphanumeric characters and other marks and signs (e.g., “!”, “\$”, “#”)

● **Network key setting**

The network key to be set for the YFGW510 has the following restrictions:

- Up to 31 characters
- Single-byte alphanumeric characters and other marks and signs (e.g., “!”, “\$”, “#”)

● **Band and channel setting regulation**

The following table shows the selectable channels.

2.4 GHz Band		5 GHz Band			
Channel	Center Frequency (GHz)	Channel	Center Frequency (GHz)	Channel	Center Frequency (GHz)
Auto	—	Auto	—	116	5.580
1	2.412	36	5.180	120	5.600
2	2.417	40	5.200	124	5.620
3	2.422	44	5.220	128	5.640
4	2.427	48	5.240	132	5.660
5	2.432			136	5.680
6	2.437	52	5.260	140	5.700
7	2.442	56	5.280		
8	2.447	60	5.300	149	5.745
9	2.452	64	5.320	153	5.765
10	2.457			157	5.785
11	2.462	100	5.500	161	5.805
12	2.467	104	5.520	165	5.825
13	2.472	108	5.540		
14	2.484	112	5.560		

● **Data rate setting regulation**

The following table shows the selectable communication data rates.

Data Rate (Mbps)	Band	
	2.4 GHz	5 GHz
Auto	Y	Y
1	Y	N
2	Y	N
5.5	Y	N
11	Y	N
6	Y	Y
9	Y	Y
12	Y	Y
18	Y	Y
24	Y	Y
36	Y	Y
48	Y	Y
54	Y	Y

Note: "Y" means selectable, "N" not selectable.

After entering all the required items, click the [Save] button to store settings in YFGW510.

In the 5GHz band, must keep the data rate of less than 12 Mbps.

D3.6 Setting of Wireless LAN 2 (WLAN C2)

Clicking the [WLAN C2] tab displays the controls and information shown in Figure D3-7.

The screenshot shows a software window titled "YFGW510Tool" with a tabbed interface. The "WLAN C2" tab is selected. The window contains the following configuration fields:

SSID	YFGW510_b0123456789b123456789c1
Security	WPA2-PSK
Encryption	AES
Network Key	@123456789@123456789@123456789@
Band	5GHz
Channel	Auto
Data Rate	Auto

A "Save" button is located at the bottom right of the configuration area.

FD0307.ai

Figure D3-7 WLAN C2 tab

This tab allows the settings for wireless LAN 2. The procedure for setting items is the same as for the wireless LAN 1. For details, see D3.5 Setting of Wireless LAN 1 (WLAN C1).

D3.7 Setting of WLAN Redundancy

Clicking the [WLAN Redundancy] tab displays the controls shown in Figure D3-8.

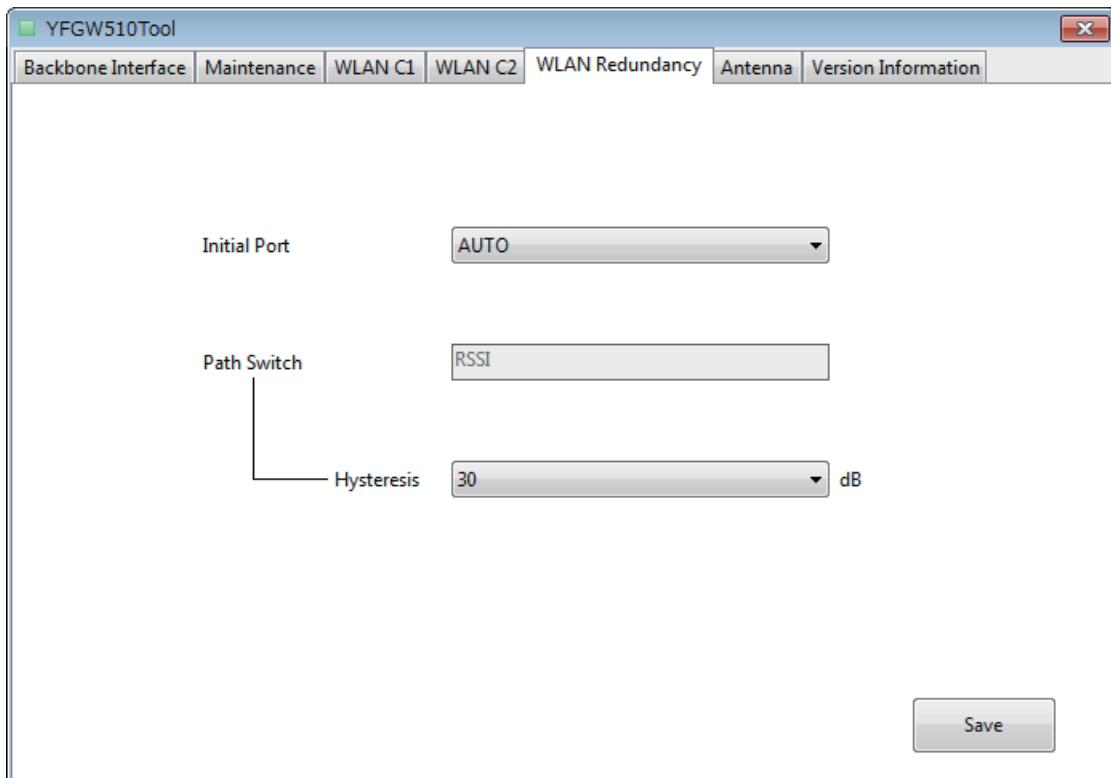

FD0308.ai

Figure D3-8 WLAN Redundancy tab

This tab allows the setting for wireless LAN redundancy.

The setting items are as follows.

Item	Descriptions	Initial Value
Initial Port	Select a wireless LAN port to be used at startup. If "AUTO" is set, a wireless LAN port with high RSSI is automatically selected.	"AUTO"
Path Switch	Select the communication path switching standard. YFGW510 supports RSSI.	"RSSI"
Hysteresis	If RSSI is selected for the communication path switching standard, specify the hysteresis width in dB.	30

After entering all the required items, click the [Save] button to store settings in YFGW510.

D3.8 Version Information

Clicking the [Version Information] tab displays the information shown in Figure D3-9.

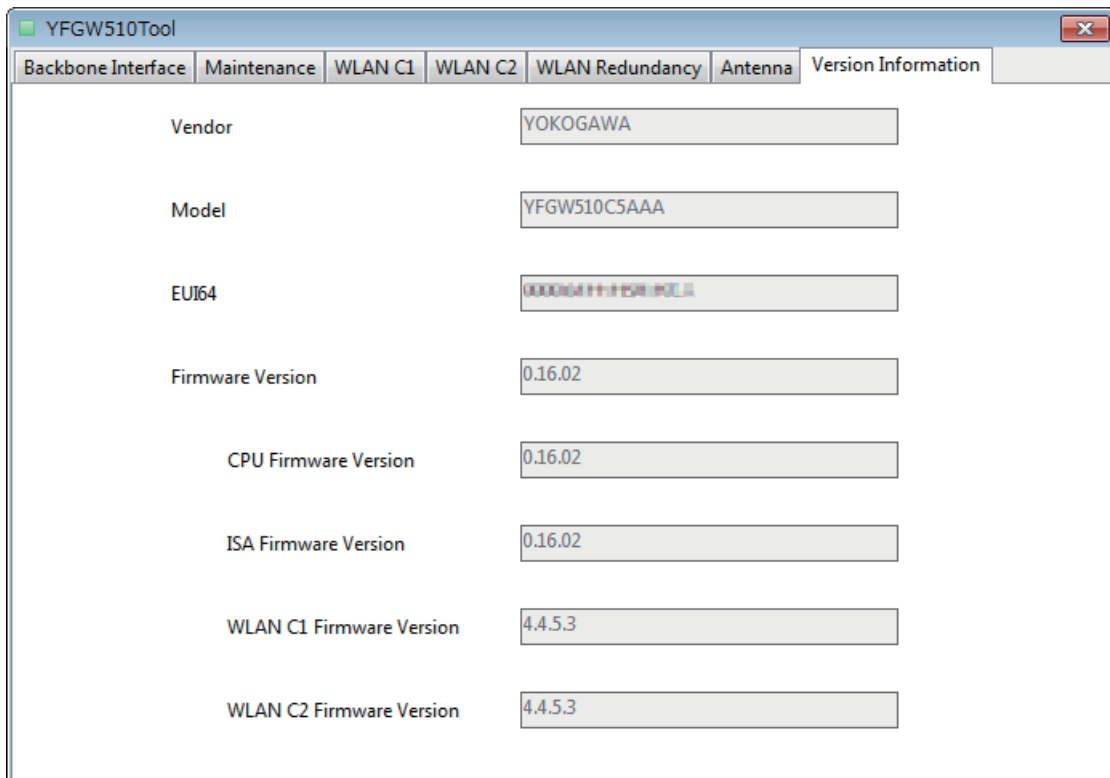

FD0309.ai

Figure D3-9 Version Information tab

This tab displays information about the YFGW510, such as the vendor name, model name and firmware versions. The tab has no setting items.

The following table shows items that can be viewed on this tab.

Item	Descriptions
Vendor	Vendor name
Model	Model name followed by part of the specification code
EUI64	64-bit Extended Unique Identifier
Firmware Version	Firmware version of the entire YFGW510
CPU Firmware Version	Firmware version of the CPU
ISA Firmware Version	Firmware version of the field wireless communication chip
WLAN C1 Firmware Version	Firmware version of the communication chip for wireless LAN 1
WLAN C2 Firmware Version	Firmware version of the communication chip for wireless LAN 2

PART-E. OPERATION AND MAINTENANCE

For information about routine maintenance, or for YFGW510 additions or replacements, consult, in advance, the YFGW410 User's Manual (IM 01W02D01-01EN).

E1. Routine Maintenance

For problems during routine maintenance, check the host system monitoring YFG510, and the device information for the Monitor of the Field Wireless Management Console provided with the YFGW410.

For details on the Monitor maintenance procedures and error prevention, see the YFGW410 User's Manual (IM 01W02D01-01EN).

During maintenance of YFGW510, check the installation and operation statuses of the main body as component to the field wireless system hardware.

Confirm that the main body is correctly installed, free of dirt and that power and communication cables are securely connected. If the main body is dirty or dusty, wipe it out by using a soft cloth moistened with water or mild soap water.

E2. Additions and Replacements

For instructions on adding or replacing YFGW510, see the YFGW410 User's Manual (IM 01W02D01-01EN).

E3. Maintenance in Hazardous Areas



IMPORTANT

Please be sure to read “YFGW510 Field Wireless Access Point Read Me First (IM 01W01E02-11EN)” for the precautions including maintenance and repair of the explosion protected type product.

In maintenance, check for loose power supply wiring, ground wiring or network cable connection.

During maintenance and repair activities, if there is need to access the system in hazardous areas via an YFGW510 communication port, PCs and other devices used must comply with the explosion-proof requirements. For details, please contact Yokogawa Electric Corporation.

Explosion-proof instruments must retain their intended properties before and after maintenance. Otherwise, hazardous conditions can arise. Be sure to consult with Yokogawa Electric Corporation for any repair and alteration.

For other field wireless system hardware components, see respective user’s manuals.

E4. Components Having Defined Life Spans

YFGW510 includes no components having defined life spans that need replacing.

For reference, the following are precautions for such components.



IMPORTANT

Precautions for components having defined life spans

- “Components having defined life spans” are those expected to wear out or break down within a 10-year period of use or in storage under normal conditions. Components designed for a life span of at least 10 years are excluded from the category.
 - The “recommended replacement cycle” is the interval between preventive maintenance for components having defined life spans. It does not guarantee breakdown-free operation during that period.
 - The recommended replacement cycle is a guideline. The actual replacement cycle may vary depending on the environmental conditions of use, such as ambient temperature.
 - The recommended replacement cycle is subject to change according to performance in the field.
-

PART-F. TROUBLESHOOTING

This part describes troubleshooting for YFGW510. If any abnormalities are identified in YFGW510 through investigation and in accordance with procedures described in the YFGW410 User's Manual (IM 01W02D01-01EN), check the following.

F1. Status Information

The YFGW510 operational status information is shown in the backbone router status (BBR_STATUS) in the Modbus register.

The status data structure and the contents are as follows.

Modbus Address	Name	Data Format	Contents
n	Data status	Unsigned 16	0x0080, fixed: normal
n + 1	Backbone router status	Unsigned 16	Backbone router status (0: connected/1: not connected)
n + 2 to n + 8		Unsigned 16	0, fixed (reserved bits)

Only the status having a Modbus address of (n + 1) is used. This indicates whether YFGW510 is connected to YFGW410 correctly.

F2. Status Indication and Responsive Measures

There are six status indicator LEDs installed on the front of YFGW510: [ACT], [LAN], [ISA], [WLAN-C1], [WLAN-C2] and [WLAN-AP].

■ YFGW510 operational status indication

The following is the LED that indicates the YFGW510 operational status.

LED	Power off	Starting up	Connect- ing	Normal	Mainte- nance	Abnormal
ACT	OFF	Orange	Orange blink	Green	Red blink	Red

The LED blinks red when the device mode is changed to Edit mode via the infrared adapter using the setup tool to configure YFGW510.

If the LED lights red, check the field wireless backbone network cable connection and communication devices such as the Layer 2 switch, etc., and fix any abnormalities. If there is no abnormality found in cable connection, check the backbone router status information described in F1. Status Information and device information by the Monitor. Any abnormality found may indicate the breakdown of YFGW510. For details of the YFGW510 device replacement method, see the YFGW410 User's Manual (IM 01W02D01-01EN).

■ Communication status indication

The following are the LEDs that indicate communication status.

LED	Power off	Starting up	Signal search	Link down	Link up	Commu- nicating	Mainte- nance	Abnor- mal
LAN	OFF	OFF	N/A	OFF	Green	Green blink	OFF	Red
ISA	OFF	OFF	N/A	N/A	Green	Green blink	OFF	Red
WLAN-C1	OFF	OFF	Orange blink	OFF	Green blink	Green	OFF	Red
WLAN-C2	OFF	OFF	Orange blink	OFF	Green blink	Green	OFF	Red
WLAN-AP	—	—	—	—	—	—	—	—

■ [LAN] LED

If the LED turns off during operation, it may indicate that communication between YFGW510 and the YFGW410 field wireless backbone network has been terminated. Investigate the communication cable connection and the status of communication devices such as the Layer 2 switch, etc., and re-establish communication.

If the LED lights red, it may indicate the breakdown of the communication function of YFGW510. Replace the main body or consult with Yokogawa Electric Corporation.

■ [ISA] LED

If the LED turns off during operation, it may indicate that communication between YFGW510 and all field wireless network devices has been terminated. Investigate the connection of the ISA100.11a antenna and the condition of the antenna extension cables, and re-establish communication. If no abnormality is found in the antenna, check the status of field wireless devices and any disturbances in wireless communication routes, and fix any problems to re-establish the communication.

If the LED lights red, it may indicate the breakdown of the communication function of YFGW510. Replace the main body or consult with Yokogawa Electric Corporation.

■ [WLAN-C1]/[WLAN-C2] LED

If the LED turns off during operation, it may indicate that communication between the field wireless backbone LAN and the wireless LAN access point has been terminated. Investigate the connection of the wireless LAN antenna and the condition of the antenna extension cables, and re-establish communication. If no abnormality is found in the antenna, check for any disturbances in wireless communication routes and fix any problems to re-establish communication.

If the LED lights red, it may indicate the breakdown of communication functions. Replace the communication devices or consult with Yokogawa Electric Corporation.

■ [WLAN-AP] LED

This LED is not used in YFGW510.

PART-G. SPECIFICATIONS

G1. Standard Specifications

Please refer to GS 01W02E01-01EN for the latest information.

G1.1 Communication Interface Specifications

Item	Field Network Specifications		Field Wireless Backbone Specifications *1		
	Standard	IEEE802.15.4	IEEE802.11a/b/g *2	100BASE-TX	100BASE-FX
Communication Interface	Frequency	2400–2483.5MHz	b/g: 2400-2483.5MHz a: 5150-5850MHz	–	
	Raw data rate	250kbps	1~54Mbps	100Mbps	100Mbps
	Radio Security	AES128bit	WPA2-PSK	–	
	RF Transmitter Power	Max 12dBm *3	Max 18dBm *3	–	
	Connector	N type	N type	RJ-45	SC connector [single pole × 2] *4
	Cable Type	coaxial	coaxial	Category 5 or higher	Multimode fiber (50/125µm or 62.5/125µm)
	Antenna	+2dBi	–	–	
	Remote Antenna	+2dBi, +6dBi, +9dBi	+2dBi, +6dBi, +9dBi	–	
	Maximum length	500m *5	b/g: 500m *5 a: 200m *5	100m	2000m
	Port	1 port	Max 2 port	1 port	1 port
	Protection	–	–	Surge	–
	Communication Protocol	Field Wireless	ISA100.11a	–	
Management, configuration, etc.		–	IEEE1588PTP v2 *6, Proprietary *7		

- *1: In outdoor wiring to Field Network or 100BASE-FX of Field Wireless Backbone, use optical fiber cables with a nonmetallic tension member, combining with YFGW610
- *2: This product requires a wireless LAN access point for connection with YFGW410 in the wireless LAN in field wireless backbone.
- *3: This is the maximum radio output at N-type connector for antenna connection. Radio output power depends on the region and the antenna type.
- *4: 2-pole SC connector cannot be used due to the conduit hole size limitation. SC connector should use Short Boot type.
- *5: The maximum length needs perfect conditions without an obstruction for radio wave transmission, using a standard antenna (2dBi). The maximum length changes with the environmental conditions and installation situations of a site.
- *6: Installation of these multiple product and YFGW410 in one field wireless subnet requires direct connection or the connection via IEEE1588PTP basis products.
- *7: TCP based custom protocol used for communication between this product and YFGW410.

■ Communication interface specifications for YFGW510 configuration

Interface	Item	Specifications
Infrared communication	Communication protocol	IrDA-SIR Ver. 1.2
	Wavelength	870 nm
	Maximum transmission speed	9600 bps
	Maximum transmission distance	30 cm
	Number of ports	1
	Purpose	Initial configuration of YFGW510

G1.2 General Specifications

■ Performance

Network Size:

Max 100 field wireless devices are connectable

Display:

2-color luminescence LED displays the operating state of this product, and the operating state of wireless communications and cable communications.

Diagnosis Functions:

CPU failures, communication interface malfunctions, outside the range, abnormal settings.

Software Download Function:

The software inside this product and the software (communication firmware, sensor firmware) inside wireless field device can update via YFGW410.

■ Installation Environment

Temperature Range:

Operating:
-40 to +65°C (altitude : up to 3000m)
Storage:
-40 to +85°C

Humidity Range:

Operating:
5 to 95 %RH (non-condensation)
Storage:
5 to 95 %RH (non-condensation)

Temperature Gradient:

Operating: $\pm 10^{\circ}\text{C/h}$ or less
Storage: $\pm 20^{\circ}\text{C/h}$ or less

Power Supply:

Voltage Range : 10.0~26.4 V DC
Rated Voltage: 24 V DC
Momentary Power Failure: Instant Disconnection
DC Power Supply Ripple Ratio: 1%p-p or less

Power Consumption:

Max. 3.5 W

Degrees of Protection:

IP66, Type 4X

Vibration Resistance:

0.21 mm P-P (10~60 Hz), 3G (60 Hz~2 kHz)

Shock Resistance:

50G 11 ms

Noise Resistance:

Electric Field : 3 V/m or less (80MHz~1GHz)
Electrostatic Discharges: 4 kV or less (contact discharge), 8 kV or less(aerial discharge)

Grounding:

Class-D grounding (no sharing ground with others)

Cooling:

Natural Air Cooling

■ Physical Specifications

Connections:

Refer to "MODEL AND SUFFIX CODES."

Housing:

Low copper cast aluminum alloy

Coating of Housing:

Urethane curing type polyester resin powder coating
Mint-green paint (Munsell 5.6BG 3.3/2.9 or its equivalent)
[for option code /X2]
Epoxy and polyurethane resin solvent coating

Name Plate and Tag:

SUS304 Stainless steel

Weight:

3.0 kg (without mounting bracket, and process connector.)

■ SOFTWARE SPECIFICATIONS

■ Field Wireless Access Point Setting Tool

This software is used for a setup and maintenance of this product. PC on which this software program installed is connected with this product via infrared communication.

■ Specifications and System Requirements

Software License:

1 license

Language:

English

Hardware Operating Environment:

Item	Recommended System Requirement
Processor	Intel Core i5-2520M or equivalent, or higher
Memory	2GB or more
Hard Disk	40GB or more (Minimum free space 15GB or more)
Display	Color: True Color (32 bits or more) Resolution: 1280 x 800 or higher
Communication Device	Ethernet Network Card

Software Operating Environment *1,*2:

OS	Type
Windows 10 Pro ^{*3}	32/64 bit
Windows 8.1 Pro Update ^{*4}	32/64 bit
Windows 7 Professional Service Pack 1 ^{*4}	32/64 bit
Windows Server 2012 R2 Standard Update ^{*4}	64 bit
Windows Server 2008 R2 Enterprise Service Pack 1 ^{*4}	64 bit
Windows Server 2008 Enterprise Service Pack 2 ^{*4}	32 bit

*1: Japanese version and English version are supported.

*2: For 64 bit OS, WOW64 (Windows 32-bit On Windows 64-bit) can be performed.

*3: Microsoft .NET Framework 4.6 is required.

*4: Microsoft .NET Framework 4.5.2 is required.

G1.3 Regulatory Compliance Statements

■ Regulatory Compliance Statements

This device contains the wireless module which satisfies the following standards.

- * Please confirm that an installation region fulfills an applicable standard. If additional regulatory information and approvals are required, contact a Yokogawa representative.

Japanese Radio Law:

Construction Type Certification Number :
007-AA0011 (ISA100.11a), 007-AA0065/66
(Wireless LAN)

CE Conformity:

- RoHS Directive: EN 50581
- ATEX Directive: See "OPTIONAL SPECIFICATION (For Explosion Protected type)"
- RE Directive:
 - Safety: EN 62311, EN 61010-1
 - EMC: EN 301 489-1, EN 301 489-17, EN 61326-1 Class A Table 2 (For use in industrial locations), EN 55011 Class A Group 1, EN 61000-6-2
 - Radio Spectrum: EN 300 328

Regulation Conformity of the Wireless Module:

- FCC Approval (Part 15C, Part 15E)
- IC Approval (RSS-210)

Safety Requirements:

CSA C22.2 No. 61010-1

G2. Model, Suffix Codes and Option Codes

Model	Suffix Codes	Description
YFGW510	Field Wireless Access Point
Output signal	-A	ISA100.11a
	-C	ISA100.11a, IEEE802.11a/b/g *1
Communication interface	1	100 BASE-TX
	2	100 BASE-FX
	5	Wireless LAN
Housing	1	Low copper cast aluminum alloy
Electrical Connection	0	G1/2 female, two electrical connections, without blind plugs
	2	1/2 NPT female, two electrical connections, without blind plugs
	4	M20 female, two electrical connections, without blind plugs
	5	G1/2 female, two electrical connections, one blind plug *1*2
	7	1/2 NPT female, two electrical connections, one blind plug *1*2
	9	M20 female, two electrical connections, one blind plug *1*2
	A	G1/2 female, two electrical connections, one 316 SST blind plug *1
	C	1/2 NPT female, two electrical connections, one 316 SST blind plug *1
	D	M20 female, two electrical connections, one 316 SST blind plug *1
---	A	Always A
License	-S	Software license
Manual language	0	Japanese
	1	English
Software media	0	Provided with DVD-ROM
	1	None
Mounting bracket	B	304 SST 2-inch pipe mounting (for horizontal piping) *3
	D	304 SST 2-inch pipe mounting (for vertical piping) *3
	J	316 SST 2-inch pipe mounting (for horizontal piping) *3
	K	316 SST 2-inch pipe mounting (for vertical piping) *3
	N	None
ISA100.11a antenna	1	Detachable antenna 2 dBi (2.4 GHz)
	A	Antenna adaptor: N-type connector *4*5
Wireless LAN antenna (1) *6	N	None
	3	Remote antenna 2 dBi (2.4 GHz), antenna cable 3 m with mounting bracket
	4	Remote antenna 2 dBi (2.4 GHz, 5 GHz), antenna cable 3 m with mounting bracket
	A	Antenna adaptor: N-type connector *4*5
Wireless LAN antenna (2) *6	N	None
	3	Remote antenna 2 dBi (2.4 GHz), antenna cable 3 m*7 with mounting bracket
	4	Remote antenna 2 dBi (2.4 GHz, 5 GHz), antenna cable 3 m*7 with mounting bracket
	A	Antenna adaptor: N-type connector *4*5*7
---	A	Always A
---	A	Always A
Option codes		<input type="checkbox"/> Optional specifications

- *1: Select in a wireless LAN client (communication interface code 5).
- *2: Select if optional specification KF27 or SF27 is not specified.
- *3: A bolt is required for wall attachment.
- *4: Select an antenna and a remote antenna cable. For details, refer to the accessory.
- *5: In order for the wireless output of an antenna to get the maximum which the area permits, adjustment by service of Yokogawa is required.
- *6: Wireless LAN antenna must be connected to this product by using external antenna cables.
- *7: Select only by 3, 4, and A of Wireless LAN antenna (1).

OPTIONAL SPECIFICATION (For Explosion Protected type)

Item	Description	Code
Factory Mutual (FM)	FM Nonincendive Approval Applicable standards: Class 3600:2011, Class 3611:2004, Class 3810:2005, NEMA 250:2003 Nonincendive for Class I, Division 2, Groups A, B, C and D; alternatively for Class I, Zone 2, Groups IIC. Suitable for Class II, Division 2, Groups F and G; Suitable for Class III, Division 1 Indoor/outdoor Type 4X in hazardous (classified) locations. Temperature Class T4 at Ta = -40°C to 65°C	FN17
	Explosionproof Approval	-
Canadian Standards Association (CSA)	CSA Non-Incendive Approval Certificate: 2655412 Applicable standards: C22.2 No.0-10, CAN/CSA-C22.2 No. 0.4-04, CAN/CSA-C22.2 No. 94-M91, C22.2 No. 213-M1987, CAN/CSA-C22.2 No. 60079-0:11, CAN/CSA-C22.2 No. 60079-15:12, CAN/CSA-C22.2 No. 61010-1-04, IEC 60529 :2001 Non-Incendive for Class I, Division 2, Groups A, B, C and D; Class II, Division 2, Groups F and G; Class III, Division I Non-Incendive Field Wiring Connections for Class I, Division 2, Groups A, B, C, D; Ex nA [nL] IIC T4. Ambient Temperature: -30 °C to +65 °C, Altitude: ≤ 3000m Enclosure: Type 4X, IP66 Cable parameters for antenna connection: Ccable: ≤ 4 nF, Lcable: ≤ 20 μH	CN17
	Flameproof Approval	-
ATEX	ATEX Type n declaration Applicable standard: EN 60079-0:2012+A11:2013, EN 60079-11:2012, EN 60079-15:2010 II 3 G Ex nA [ic] IIC T4 Gc Enclosure: IP66 Amb. Temp.(Tamb): -30 to 65°C (-22 to 149°F)	KN27
	ATEX Flameproof Approval Certificate: DEKRA 15ATEX0042 X Applicable Standard: EN 60079-0:2012+A11:2013, EN 60079-1:2007, EN 60079-11:2012 II 2 G Ex d [ib] IIC T4 Gb Um: 250 V Amb. Temp.(Tamb): -40 to 65°C (-40 to 149°F)	KF27
IECEX	IECEX Type n Approval Certificate: IECEX DEK 14.0028 Applicable standard: IEC60079-0:2011, IEC60079-11:2011, IEC60079-15:2010 Ex nA [ic] IIC T4 Gc Enclosure: IP66 Amb. Temp.(Tamb): -30 to 65°C (-22 to 149°F)	SN27
	IECEX Flameproof Approval Certificate: IECEX DEK 15.0021X Applicable Standard: IEC 60079-0:2011, IEC 60079-1:2007, IEC 60079-11:2011 Ex d [ib] IIC T4 Gb Um: 250 V Amb. Temp.(Tamb): -40 to 65°C (-40 to 149°F)	SF27

OPTIONAL SPECIFICATIONS

Item	Description	Code
Painting	Coating change Anti-corrosion coating	X2

ACCESSORY

Item	Parts Number	Description
Remote antenna cable	F9915KU	3m with mounting bracket
	F9915KV	13m (3m+10m) with surge protective device and mounting bracket
Antenna	F9915KW	2dBi Standard Antenna (2.4GHz) *1
	F9915KY	6dBi High gain antenna (2.4GHz) *2
	F9195VG	9dBi High gain antenna (2.4GHz) *2
	F9195VA	2dBi Standard Antenna (2.4GHz,5GHz) *1

*1: Standard antenna cannot perform direct connection to this product at wireless LAN.

*2: High gain antenna cannot perform direct connection to this product.

G3. External Dimensions

G3.1 100BASE-TX/100BASE-FX Model

■ Vertical pipe mounting

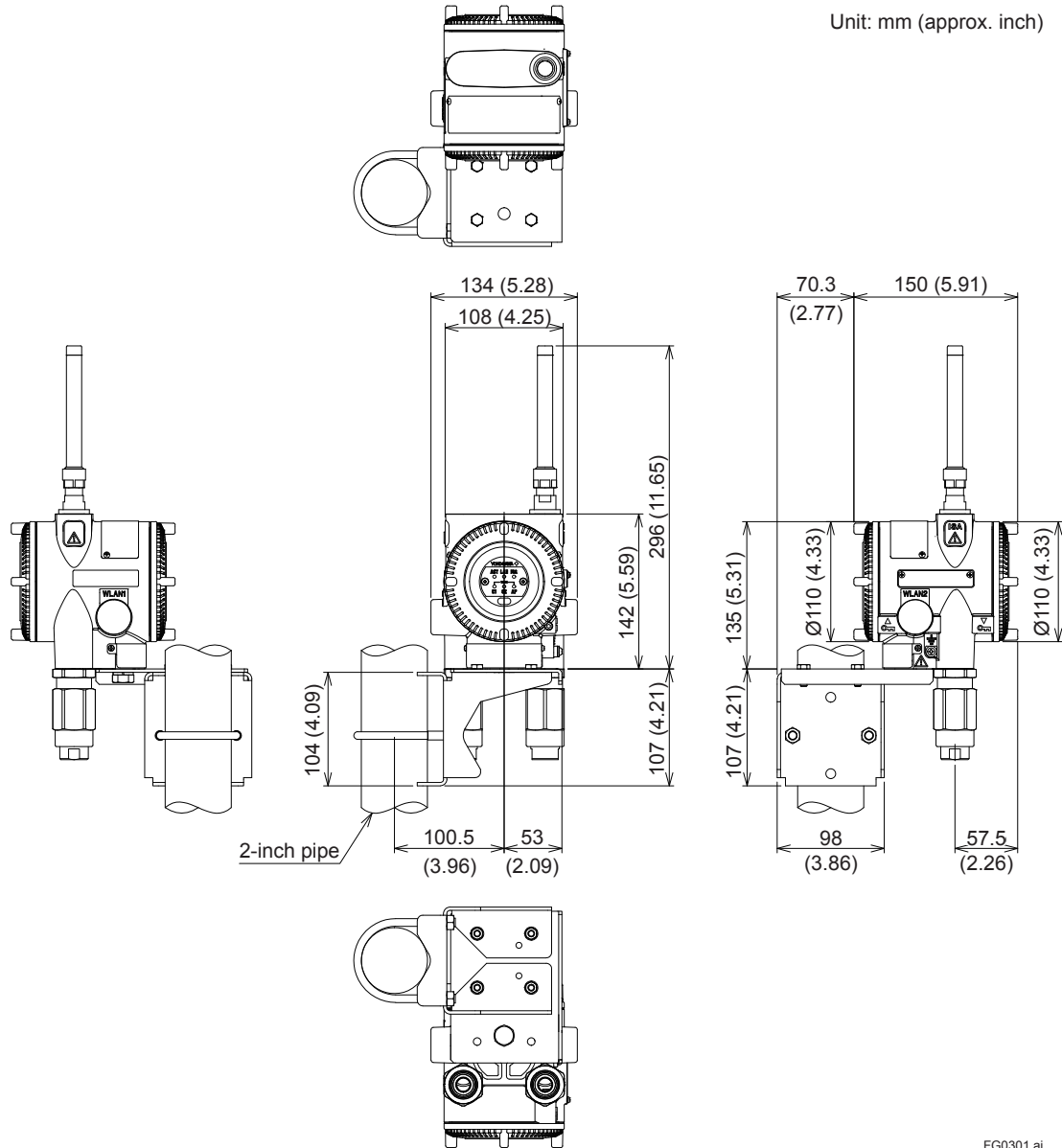

FG0301.ai

G3.2 Wireless LAN Single Model

■ Vertical pipe mounting

Unit: mm (approx. inch)

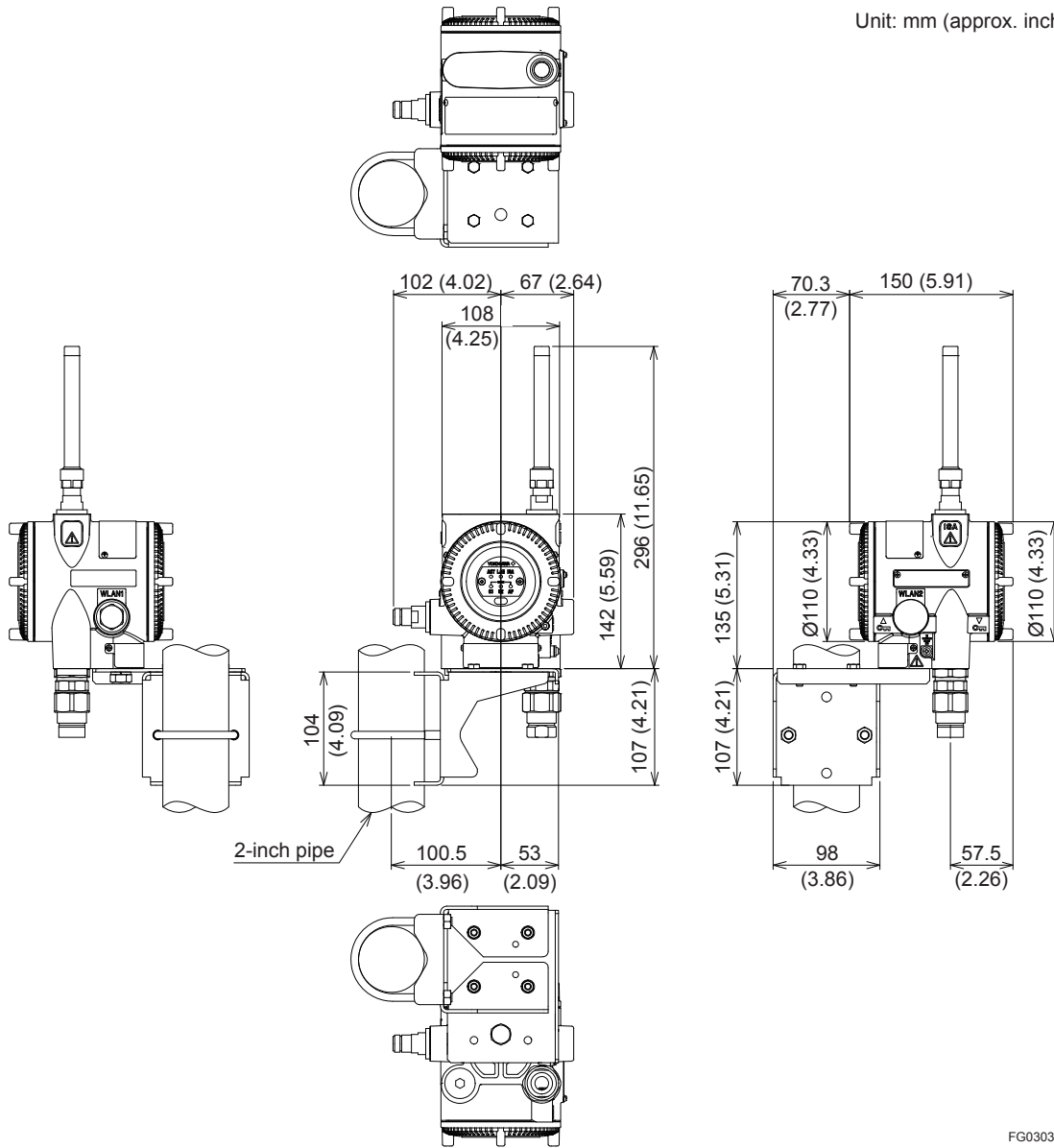

FG0303.ai

G3.3 Wireless LAN Redundant Model

■ Vertical pipe mounting

Unit: mm (approx. inch)

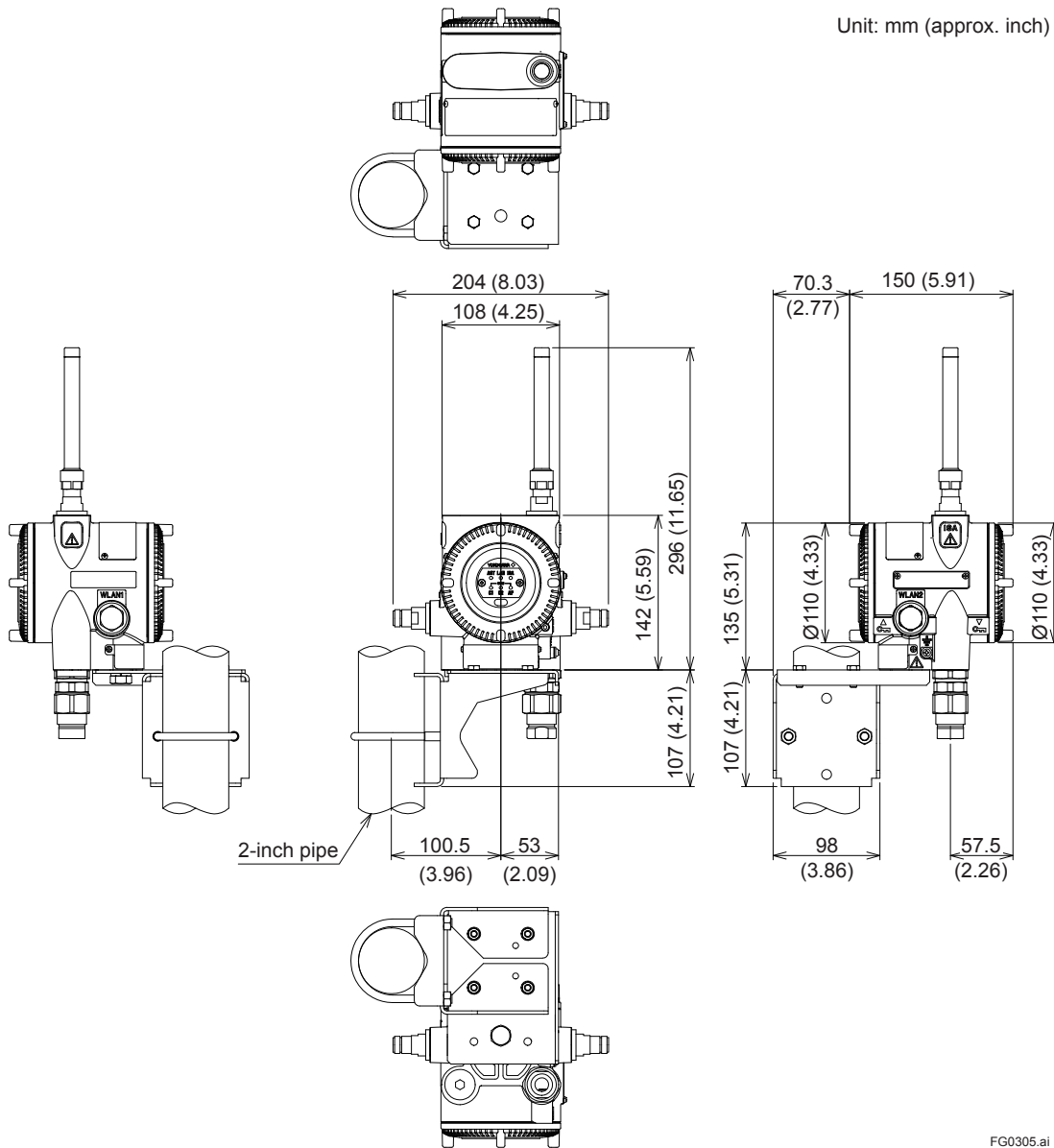

FG0305.ai

■ Horizontal pipe mounting

Unit: mm (approx. inch)

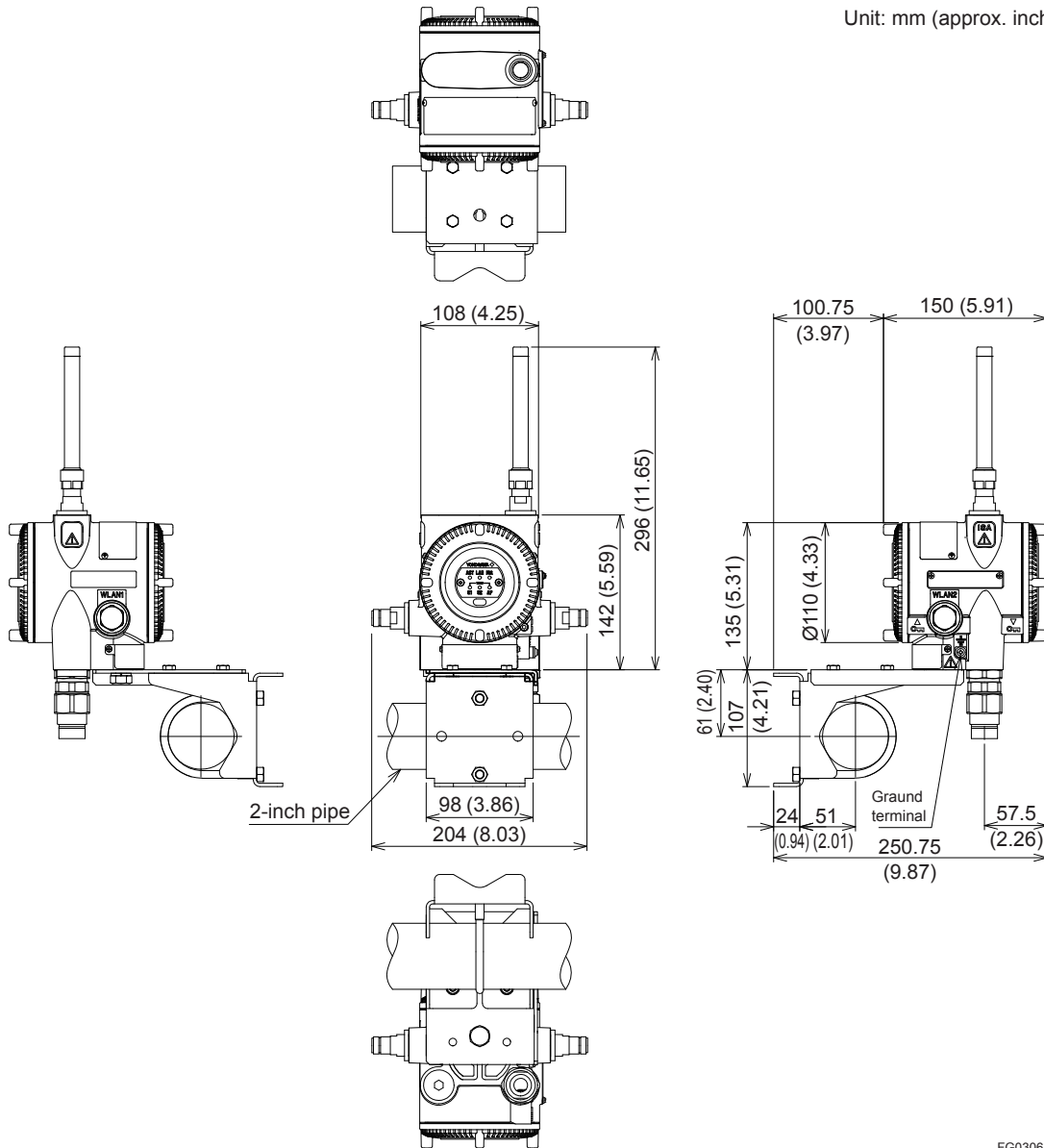

FG0306.ai