



EKS/EKM36

COMPACT MOTOR FEEDBACK SYSTEM
FOR HIGHLY DYNAMIC SERVO DRIVES

Motor feedback systems rotary HIPERFACE DSL®

SICK
Sensor Intelligence.

COMPACT MOTOR FEEDBACK SYSTEM FOR HIGHLY DYNAMIC SERVO DRIVES



Product description

From a mechanical point of view, the EKS/EKM36 motor feedback system is based on the proven 36 mm design. This design is both compact and rugged, and has been proven many times over in a wide range of applications and

surroundings. In combination with an absolute location indicator system with a resolution of up to 20 Bits per revolution and a maximum of 4,096 revolutions, this design is unique in its class.

At a glance

- Motor feedback system with HIPERFACE DSL® interface
- Compact, robust design with 36 mm diameter
- Up to 20 bit resolution per revolution and 4,096 revolutions measurable with the multiturn system
- Facility for connecting an external temperature sensor
- E²Prom with 8 kbyte of free memory space
- SIL2-certified (only valid for EKS/EKM36-2...)
- Service life histogram

Your benefits

- Saving all analog components on the controller part through exclusively digital data transmission
- Enormous cost saving thanks to the separate encoder cable no longer being necessary, data transmitted synchronously to the controller cycle
- Minimal cabling thanks to integration of the encoder communication into the motor cable
- Optimization of the controller circuit via automated synchronization with the controller cycle



Additional information

Detailed technical data	3
Type code	5
Ordering information	5
Dimensional drawings	6
Proposed fitting	6
PIN assignment.	7
Diagrams.	7
Supported resources for HIPERFACE DSL®.	8
Supported access levels	9
Overview of warnings and fault indications.	9
Recommended accessories	10

→ www.sick.com/EKS_EKM36

For more information, simply enter the link or scan the QR code and get direct access to technical data, CAD design models, operating instructions, software, application examples, and much more.



Detailed technical data

Performance

	Singleturn 18	Singleturn 20	Multiturn 18	Multiturn 20
Resolution per revolution	18 bit	20 bit	18 bit	20 bit
Number of the absolute ascertainable revolutions	1		4,096	
Measuring step per revolution	262,144	1,048,576	262,144	1,048,576
Signal noise (σ)	$\pm 5''^{1)}$	$\pm 4''^{1)}$	$\pm 5''^{1)}$	$\pm 4''^{1)}$
Error limits positional values integral non-linearity	$\pm 80''$	$\pm 60''$	$\pm 80''$	$\pm 60''$
Error limits positional values differential non-linearity	$\pm 40''$			
System accuracy	$\pm 120''$	$\pm 100''$	$\pm 120''$	$\pm 100''$
Speed when switching on and resetting the motor feedback system	$\leq 6,000 \text{ min}^{-1}$			
Available memory area	8,192 Byte			

¹⁾ See diagrams "position noise" and "gain".

Interfaces

Type of code for the absolute value	Binary
Code sequence	Increasing, when turning the shaft For clockwise rotation, looking in direction "A" (see dimensional drawing)
Communication interface	HIPERFACE DSL®
Initialization time	Max. 500 ms ¹⁾
Measurement external temperature resistance	32 bit value, without prefix (1 Ω) 0 ... 209.600 Ω At -40 °C ... +160 °C: NTC +2K; PTC+3K
Available memory area	8,192 Byte

¹⁾ From reaching a permitted operating voltage.

Electrical data

Connection type	Connector, 4-pin
Supply voltage range	7 V ... 12 V
Warm-up time voltage ramp	Max. 180 ms ¹⁾
Output current	$\leq 150 \text{ mA}^{2)}$
Output frequency for the digital position-value	0 kHz ... 75 kHz

¹⁾ Duration of voltage ramp between 0 and 7.0 V.

²⁾ Current rating applies when using interface circuit suggestions as shown in HIPERFACE DSL® manual (8017595).

Mechanical data

	Singleturn 18	Singleturn 20	Multiturn 18	Multiturn 20
Shaft version	Tapered shaft			
Flange type / stator coupling	Stator coupling			
Dimensions	See dimensional drawing			
Weight	0.1 kg			
Moment of inertia of the rotor	4.5 gcm ²			
Operating speed	$\leq 12,000 \text{ min}^{-1}$		$\leq 9,000 \text{ min}^{-1}$	
Angular acceleration	$\leq 200,000 \text{ rad/s}^2$			

	Singleturn 18	Singleturn 20	Multiturn 18	Multiturn 20
Operating torque	0.2 Ncm			
Start up torque	0.3 Ncm			
Permissible shaft movement, radial static/ dynamic	± 0.1 mm / ± 0.05 mm			
Permissible shaft movement, axial static/ dynamic	± 0.5 mm / ± 0.1 mm			
Life of ball bearings	3.6 x 10 ⁹ revolutions			

Ambient data

Operating temperature range	-20 °C ... +115 °C ¹⁾
Storage temperature range	-40 °C ... +125 °C
Resistance to shocks	100 g, 6 ms (according to EN 60068-2-27)
Frequency range of resistance to vibrations	50 g, 10 Hz ... 2,000 Hz (EN 60068-2-6)
EMC	According to EN 61000-6-2, EN 61000-6-4 and IEC 61326-3 ²⁾
Enclosure rating	IP40, with mating connector inserted and closed cover (acc. to EN 60529-1) ³⁾

¹⁾ Given typical thermal connection between motor flange and encoder stator coupling. The max. internal sensor temperature may not exceed 125 °C.

²⁾ The EMC according to the standards quoted is achieved when the motor feedback system is mounted in an electrically conductive housing, which is connected to the central earthing point of the motor controller via a cable screen. The GND-(0 V) connection of the supply voltage is also grounded here. If other shielding concepts are used, users must perform their own tests.

³⁾ With mating connector inserted and closed cover.

Safety-related parameters

Note	Following values only valid for SIL2 certified versions
Safety integrity level	SIL2 (IEC 61508), SILCL2 (EN 62061) ¹⁾
Category	3 (EN ISO 13849)
Test rate	1 h
Maximum demand rate	216 µs
Performance level	PL d (EN ISO 13849)
Safety related resolution	Channel 1 = 18 bit or 20 bit, channel 2 = 9 bit
PFH _D : Probability of dangerous failure per hour	4 x 10 ⁻⁸ ²⁾
T _M (mission time)	20 years (EN ISO 13849)
MTTF _D : mean time to dangerous failure	500 years (EN ISO 13849)

¹⁾ For more detailed information on the exact configuration of your machine/unit, please consult your relevant SICK branch office.

²⁾ The values displayed apply to a diagnostic degree of coverage of 90%, which must be achieved by the external drive system.

Type code

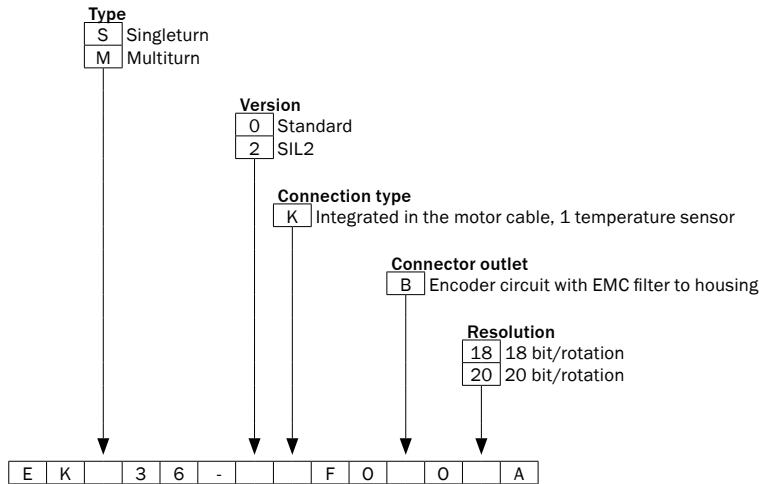

Ordering information

Singleturn for integration

- **Shaft version:** tapered shaft
- **Mechanical feature:** Spring mounting plate, Ø 36
- **Electrical interface:** HIPERFACE DSL®
- **Connection type:** connector, 4-pin

Type	Part no.
EKS36-0KF0B018A	1084229
EKS36-0KF0B020A	1084230

- **Shaft version:** tapered shaft
- **Mechanical feature:** Spring mounting plate, Ø 36
- **Safety system:** ✓
- **Electrical interface:** HIPERFACE DSL®
- **Connection type:** connector, 4-pin

Type	Part no.
EKS36-2KF0B018A	1084231
EKS36-2KF0B020A	1084232

Multiturn for integration

- **Shaft version:** tapered shaft
- **Mechanical feature:** Spring mounting plate, Ø 36
- **Electrical interface:** HIPERFACE DSL®
- **Connection type:** connector, 4-pin

Type	Part no.
EKM36-0KF0B018A	1084233
EKM36-0KF0B020A	1084234

- **Shaft version:** tapered shaft
- **Mechanical feature:** Spring mounting plate, Ø 36
- **Safety system:** ✓
- **Electrical interface:** HIPERFACE DSL®
- **Connection type:** connector, 4-pin

Type	Part no.
EKM36-2KF0B018A	1084235
EKM36-2KF0B020A	1084236

Dimensional drawings (Dimensions in mm (inch))

EKx36-xKF0B0xxA

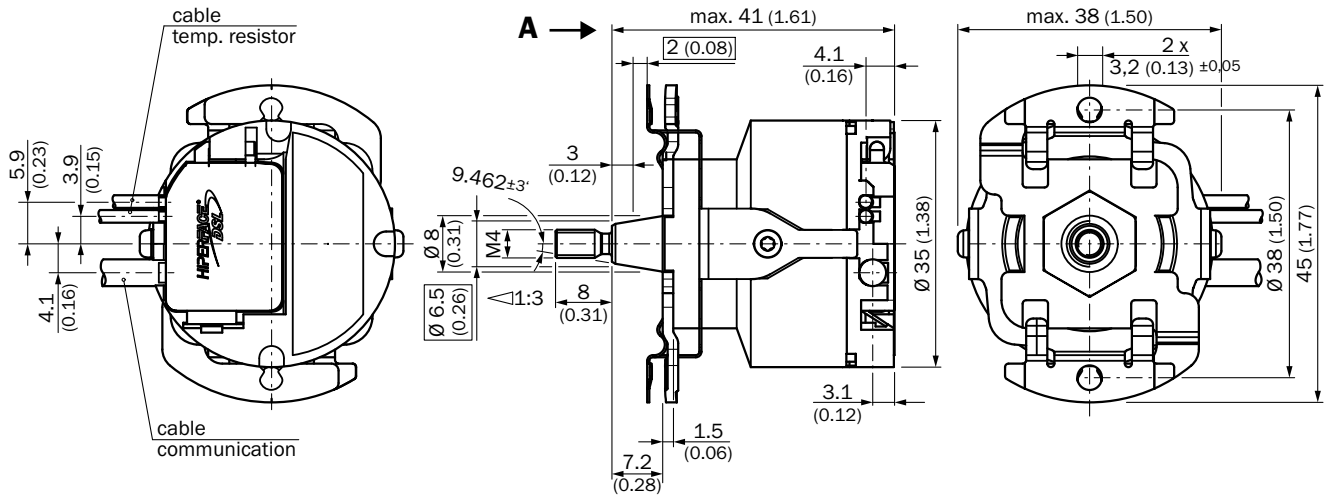

Proposed fitting

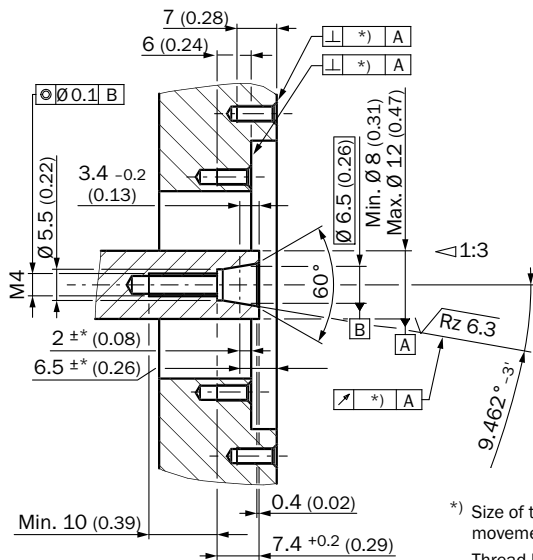

*) Size of tolerance reduce the allowed movement of the shaft, see data sheet.
Thread holes according DIN 13 with counterbore according DIN 76 min. 1.05 x diameter of thread.

- ① Nominal position
- ② The size of the tolerance reduces the permissible wave movement, see data sheet
- ③ Threaded holes in accordance with DIN 13 with recesses in accordance with DIN 76 min. 1.05 x thread diameter

PIN assignment

Pin assignment supply/communication EKx36-xKFOB0xxA

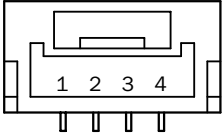

Integrated in the motor cable = J, K

PIN	Signal	Explanation
1		not connected
2	+U _y /DSL+	Power supply/DSL-Data
3	GND/DSL-	Ground connection/DSL-Data
4	housing	cable shield

Recommended outer diameter of stranded cable: 4 mm +0/-0.3 mm
 Recommended mating connector: JST (GHR-04V-S)

Diagrams

Typ. current consumption [A]

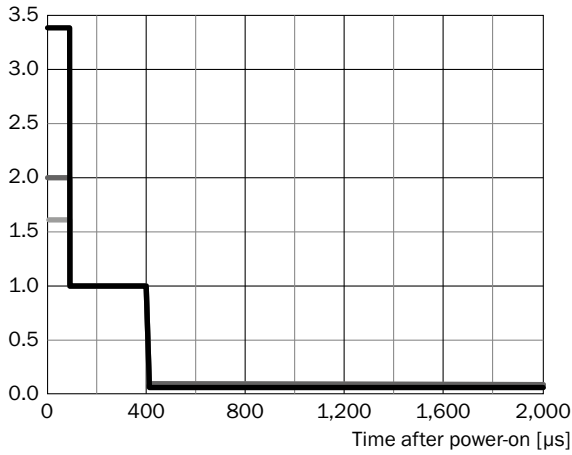

- 7 V
- 8 V
- 12 V

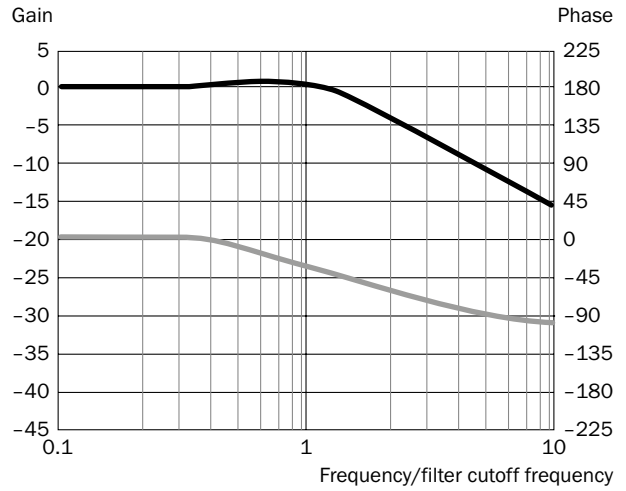

- Gain [dB]
- Phase [°]

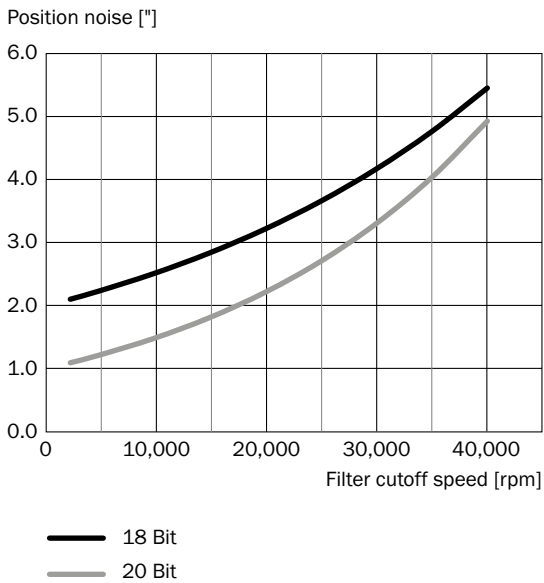

Signal noise is measured as 1 standard deviation (σ) of the value distribution.
 Position filter cutoff speed is set by resource 10Ah, see page 11.

Supported resources for HIPERFACE DSL®

Resource Index	Function	Size (max. Offset)	Read access	Write access	Name
000h	Root node		0	-	ROOT
001h	Designation node		0	-	IDENT
002h	Monitoring node		0	-	MONITOR
003h	Administration node		0	-	ADMIN
004h	Counter node		0	-	COUNTER
005h	Data storage node		0	-	DATA
006h	Sensor hub nodes		0	-	SENSHUB
080h	Type of encoder	2	0	-	ENCTYPE
081h	Solution	4	0	-	RESOLUTN
082h	Range	4	0	-	RANGE
083h	Type code designation	18	0	-	TYPECODE
084h	Serial number	10	0	-	SERIALNO
085h	Firmware version number	20	0	-	FWREVNO
086h	Firmware date	8	0	-	FWDATE
087h	EEPROM size	2	0	-	EESIZE
0C0h	Temperature range	4	0	-	TEMPRNG
0C1h	Temperature	2	0	-	TEMPRTUR
0C2h	LED current range	4	0	-	LEDRANGE
0C3h	LED current	2	0	-	LEDCURR
0C4h	Supply voltage range	4	0	-	SUPRANGE
0C5h	Supply voltage	2	0	-	SUPVOLT
0C6h	Rotation speed range	2	0	-	SPEEDRNG
0C7h	Rotation speed	2	0	-	SPEED
0C8h	Max. angular acceleration	2	0	-	ACCRANGE
0CBh	Lifetime	8	0	-	LIFETIME
0CCh	Error protocol	8	0	-	ERRORLOG

Resource Index	Function	Size (max. Offset)	Read access	Write access	Name
0CDh	Usage histogram	4	0	-	HISTOGRM
0CFh	Displays vector length	2	0	-	VECLEN
100h	Reset	0	-	0	RESET
101h	Determine position	8	-	2	SETPOS
104h	Determine access level	8	0	0	SETACCES
105h	Change access key	8	-	0	CHNGEKEY
107h	Warning limits	8	0	2	UWARNING
108h	Reset to the factory setting	8	-	2	FACRESET
109h	User-defined encoder index	2	0	3	ENCIDENT
10Ah	Position filter setting	4	0	3	POSFILT
10Ch	Import of HF data fields	0	-	2	RMUSRDAT
120h	Read counter	4	0	-	READCNT
121h	Increment counter, operational lifetime: max. 300,000 increments	0	-	0	INCCOUNT
122h	Reset the counter	0	-	2	RESETCNT
130h	Load file	8	-	0	LOADFILE
131h	Access file	File size	User-defined	User-defined	RWFILE
132h	File status	4	-	-	FILESTAT
133h	Create/delete/change file	8	-	User-defined	MAKEFILE
134h	Directory	8	0	-	DIR
200h	I/O access	4	0	0	ACCESSIO
201h	Manage I/O	4	0	2	MANAGEIO

Supported access levels

Access level	User	Standard access key
0	Execute (default setting)	0000 (30 30 30 30h)
1	Operator	1111 (31 31 31 31h)
2	Maintenance	2222 (32 32 32 32h)
3	Authorized client	3333 (33 33 33 33h)
4	User service	4444 (34 34 34 34h)

Overview of warnings and fault indications

Error type	Error register	Error bit	Description
Position (incremental)	00h	0	A Protocol reset was executed
	00h	1	Acceleration overflow, invalid position
	00h	2	Test running
	00h	4	Internal error in angular tracking, invalid position
	00h	5	Internal error in vector length, invalid position
	00h	6	Internal error in position counter, invalid position
	00h	7	Internal error in position synchronization, invalid position

Error type	Error register	Error bit	Description
Position (absolute)	01h	0	Error in absolute position in rotation
	01h	1	Error 1 in absolute position in several rotations
	01h	2	Error 2 in absolute position in several rotations
	01h	3	Error 3 in absolute position in several rotations
	01h	4	Position cross check error (only safety versions)
Initialization	02h	0	Switch-on self-test undertaken (only safety versions)
	02h	1	Warning safety parameter: error could not be rectified (only safety versions)
	02h	2	Warning safety parameter: error could not be rectified (only safety versions)
	02h	3	Error calibration data
	02h	4	Internal communications error 1
	02h	5	Internal communications error 2
	02h	6	Internal general error
Test	03h	0	Critical temperature
	03h	1	Critical LED current
	03h	2	Critical supply voltage
	03h	3	Critical rotation speed
	03h	4	Critical acceleration
	03h	5	Critical overflow
	03h	6	Internal monitoring error
Access to resources	04h	0	Invalid argument given during resource access procedure
	04h	1	Resource access refused due to incorrect access level
	04h	2	Internal error during resource access
	04h	3	Error when accessing a user file
User defined Warnings	07h	0	User-defined warning 0
	07h	1	User-defined warning 1
	07h	2	User-defined warning 2
	07h	3	User-defined warning 3

[Recommended accessories](#)

Mounting systems

Other mounting accessories

Mounting tools



Brief description	Type	Part no.
Mounting tools	BEF-MW-EKX36	2060224

Dimensional drawings → [page 11](#)

Connection systems

Plug connectors and cables

Connecting cables with female connector

Figure	Brief description	Cable length	Type	Part no.
	Head A: female connector, stranded cable, 2-pin, straight	0.2 m	DOL-0B02-G0M2XC1	2062083
	Head B: open cable ends	0.3 m	DOL-0B02-G0M3XC1	2091818
	Cable: HIPERFACE DSL®, twisted, unshielded	0.4 m	DOL-0B02-G0M4XC1	2086286
	Head A: female connector, stranded cable, 3-pin, straight	0.43 m	DOL-0B03-G0M4XC1	2087314
Head B: open cable ends				
	Cable: HIPERFACE DSL®, shielded			

Dimensional drawings → [page 11](#)

Further accessories

Programming and configuration tools

Figure	Brief description	Type	Part no.
	SVip® LAN programming tool for all motor feedback systems	PGT-11-S LAN	1057324
	SVip® WLAN programming tool for all motor feedback systems	PGT-11-S WLAN	1067474

Dimensional drawings → [page 13](#)

Dimensional drawings for accessories (Dimensions in mm (inch))

Other mounting accessories

BEF-MW-EKX36

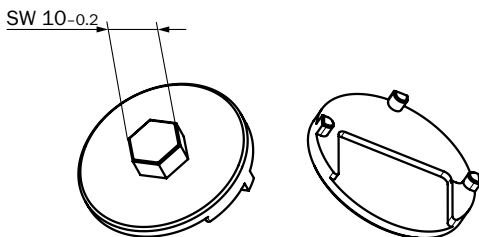

Plug connectors and cables

DOL-0B02-G0MxXC1

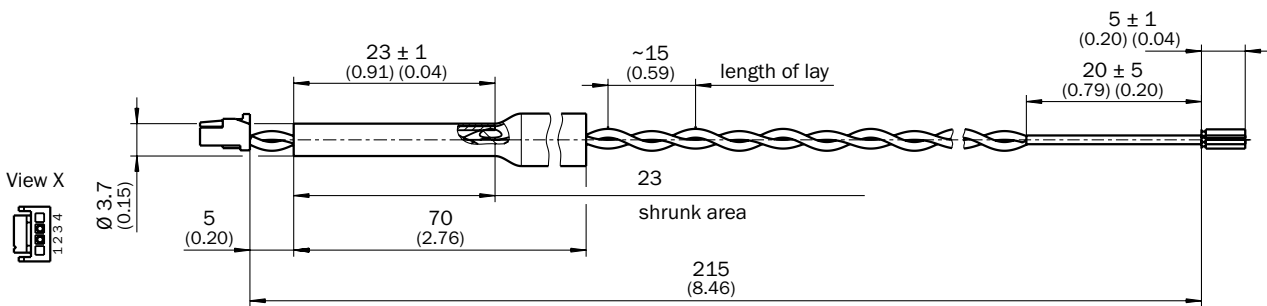

PIN	Color
1	
2	grey
3	green
4	

DOL-0B02-G0M4XC1

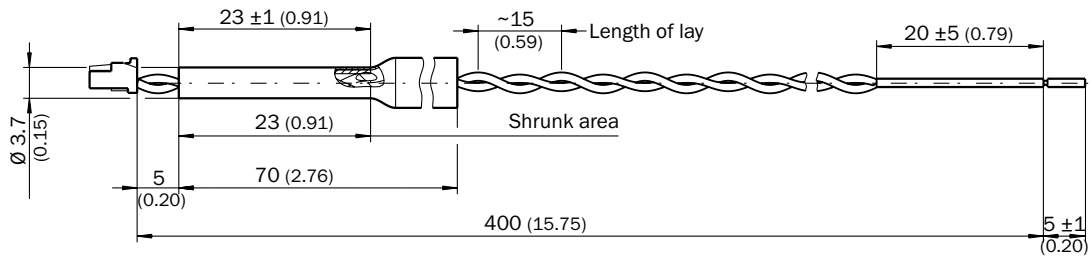

DOL-0B03-G0M4XC1

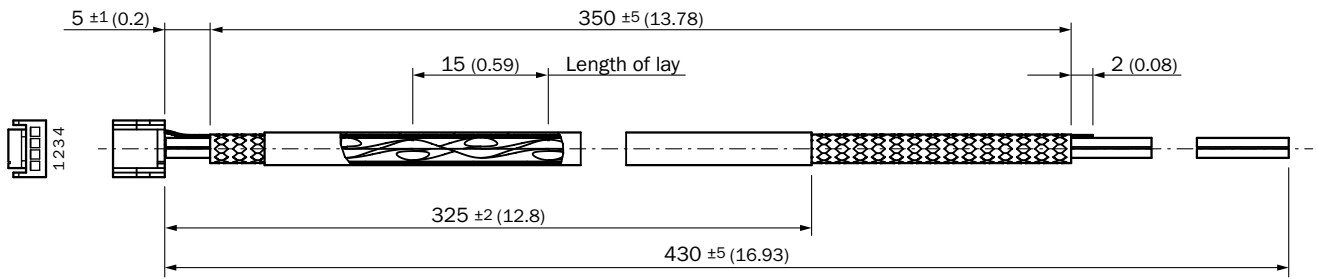

PIN	Color
1	-
2	Gray
3	Green
4	Shield

Programming and configuration tools

PGT-11-S LAN

PGT-11-S WLAN

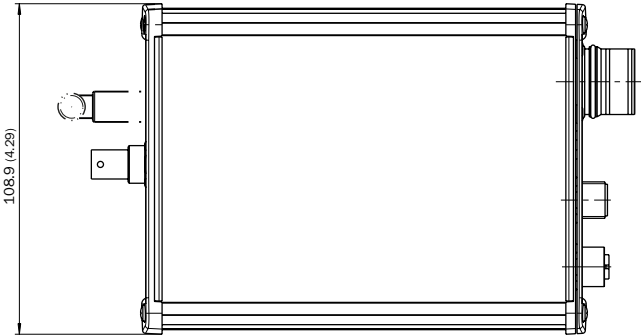
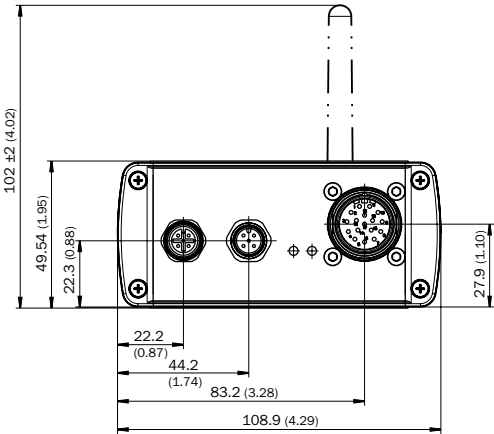
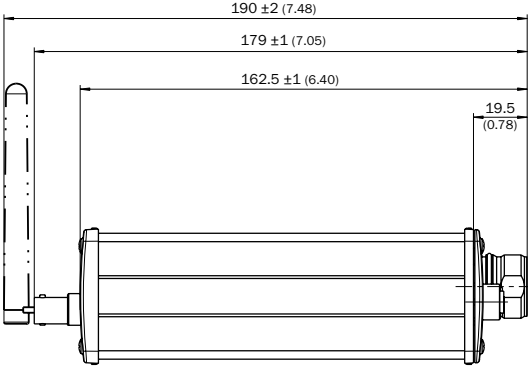

REGISTER AT WWW.SICK.COM TO TAKE ADVANTAGE OF OUR FOLLOWING SERVICES FOR YOU



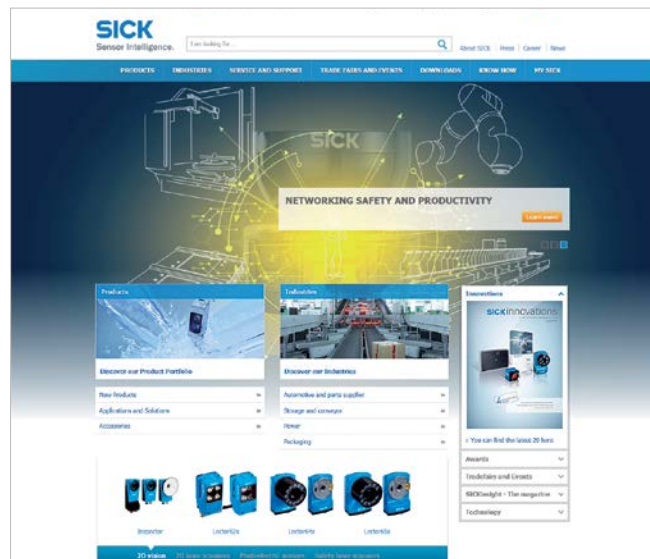

- ✔ Access information on net prices and individual discounts.
- ✔ Easily order online and track your delivery.
- ✔ Check your history of all your orders and quotes.
- ✔ Create, save, and share as many wish lists as you want.
- ✔ Use the direct order to quickly order a big amount of products.
- ✔ Check the status of your orders and quotes and get information on status changes by e-mail.
- ✔ Save time by using past orders.
- ✔ Easily export orders and quotes, suited to your systems.



SERVICES FOR MACHINES AND PLANTS: SICK LifeTime Services

Our comprehensive and versatile LifeTime Services are the perfect addition to the comprehensive range of products from SICK. The services range from product-independent consulting to traditional product services.



- 
Consulting and design
 Safe and professional
- 
Product and system support
 Reliable, fast, and on-site
- 
Verification and optimization
 Safe and regularly inspected
- 
Upgrade and retrofits
 Easy, safe, and economical
- 
Training and education
 Practical, focused, and professional

SICK AT A GLANCE

SICK is a leading manufacturer of intelligent sensors and sensor solutions for industrial applications. With more than 8,000 employees and over 50 subsidiaries and equity investments as well as numerous agencies worldwide, we are always close to our customers. A unique range of products and services creates the perfect basis for controlling processes securely and efficiently, protecting individuals from accidents and preventing damage to the environment.

We have extensive experience in various industries and understand their processes and requirements. With intelligent sensors, we can deliver exactly what our customers need. In application centers in Europe, Asia and North America, system solutions are tested and optimized in accordance with customer specifications. All this makes us a reliable supplier and development partner.

Comprehensive services round out our offering: SICK LifeTime Services provide support throughout the machine life cycle and ensure safety and productivity.

For us, that is “Sensor Intelligence.”

Worldwide presence:

Australia, Austria, Belgium, Brazil, Canada, Chile, China, Czech Republic, Denmark, Finland, France, Germany, Great Britain, Hungary, Hong Kong, India, Israel, Italy, Japan, Malaysia, Mexico, Netherlands, New Zealand, Norway, Poland, Romania, Russia, Singapore, Slovakia, Slovenia, South Africa, South Korea, Spain, Sweden, Switzerland, Taiwan, Thailand, Turkey, United Arab Emirates, USA, Vietnam.

Detailed addresses and further locations → www.sick.com