

General Specifications

Model CM6G Gas Calorimeter

GS 11R02A01-02E

■ GENERAL

Model CM6G Gas Calorimeter is used to measure and control the calorific value or Wobbe Index (WI) of the sample gas. In this calorimeter the sample gas is burnt at the burner with air and the temperature difference between the combustion exhaust gas and the feed air at the burner inlet is detected by using a thermocouple.

This calorimeter detects the flow rate of both the sample gas and the air as the differential pressure by using the orifice and converts the differential pressure to the digital signal then compensates the flow rate variation by the digital calculation. This method gives an excellent high reliability, therefore it can be used for the control of thermal input for the various type furnaces in the steel mill and petrochemical industries, also for the calorie control of the town gas.



■ TYPICAL SYSTEM CONFIGURATION

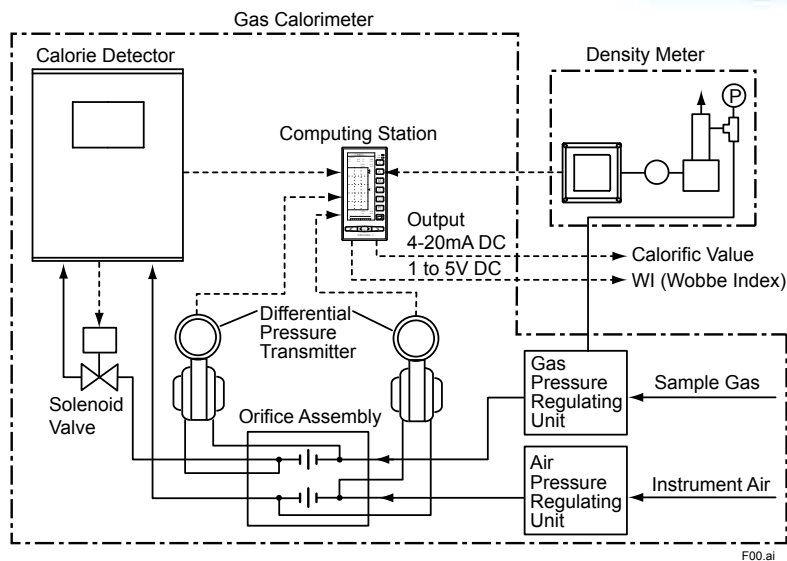

■ COMPONENTS AND FUNCTIONS

Item	Function / Description
Calorie detector	Detects WI or calorific value. Generates an alarm and takes protective actions when the burner flame goes out or abnormal combustion occurs.
Computing station (digital)	Calculates WI or calorific value. Displays selected parameters, e.g., each differential pressure and calorific value. Adjusts zero / span and others.
Density meter	Measures density used for calculation of calorific value. Not required for WI measurement.
Differential pressure transmitter	Detects differential pressure of gas and air before and after orifice, and converts it to an electrical signal.
Orifice assembly	Gas and air orifices housed in the constant temperature chamber.
Solenoid valve	Serves as a safety valve to shut off the sample gas flow.

■ STANDARD SPECIFICATIONS

EMC: EMC Regulatory Arrangement in Australia and New Zealand (RCM) EN61326-1 Class A
Korea Electromagnetic Conformity Standard Class A

1. Town Gas Application

Measurement Object:

Measurement and control of WI or the calorific value of fuel gas for town gas.

Measuring Range: 3 to 62 MJ/Nm³

Sample Conditions:

Dust: 5 mg/Nm³ or less
Temperature: 50°C or less
Humidity: dew point of 0°C or less
Pressure: (1) 10 to 20 kPa
(2) 10 kPa or under: with pump
(3) 100 to 600 kPa: with pressure reducing valve

Range:

Select scale range (Span):
General Gas: 30 to 50% of maximum value of the span.

Butane or Butene + Air:
20 to 30% of maximum value of the span.

Propane or Propylene + Air:
25 to 40% of maximum value of the span.

Output: 1 to 5 V DC, 4 to 20 mA DC (simultaneously), non-isolated, load resistance 750 Ω or less

Alarm Contact Output:

Flame off alarm; 100 V AC, 5 A, closed when alarm occurs (resistance load) when contact is opened, the leakage current is 2mA or less (100V AC)

Temperature alarm; 100 V AC, 3 A, closed when alarm occurs (resistance load)

Contact Input:

Remote ignition (Custom order);
24 V DC, 0.1A or more

Repeatability:

Measurement	Measuring range Note 1	Repeatability
WI	High calorific value	±0.5% of measured value
	Low calorific value	±1.0% of measured value
Calorific value MJ/Nm ³	High calorific value	±1.0% of measured value
	Low calorific value	±1.5% of measured value

Note 1: High calorific value means 6.3 MJ/Nm³ or higher.
Low calorific value means below 6.3 MJ/Nm³.

Sample Gas Flow Rate: Approx. 10 l/min

Response Time (Note 2):

Max. WI measured	Dead time	Response Time (63.2%)
50 or more	30 sec or less	60 sec or less
32 or more, less than 50	27 sec or less	53 sec or less
13 or more, less than 32	23 sec or less	47 sec or less
13 or less	21 sec or less	41 sec or less

Note 2: Response time varies depending on the WI of a sample gas. This is due to the different sample gas flow rate of the calorimeter. The flow rate is preset depending on the WI of the sample gas to prevent the calorific value at the detector burner from exceeding the upper limit.

Utility:

Instrument Air: Approx. 50 NI/min, pressure 300 to 700 kPa, dew point of 0°C or less

Power Supply: 100 V AC ±10%, single phase, 50/60 Hz (Note 3), 860 VA max.

Note 3: In case of low calorific value measurement, frequency variation should be within ±0.4%.
If frequency variation exceeds ±0.4%, consult with Yokogawa.

Panel:

Construction: For indoor installation, rack panel
Paint Color: Munsell 3.2PB7.4/1.2 (inside and outside)

Ambient temperature:

0 to 40°C and no rapid change in ambient temperature is allowed.

Rapid change here means a change of approximately 10°C within 30 minutes.

2. Steel Mill Application

Measurement Object:

Measurement and control of WI or the calorific value of fuel gas for a steel mill.

Measuring range: 3 to 62 MJ/Nm³

Sample Conditions:

Dust: 100 mg/Nm³ or less
Temperature: 50°C or less
Pressure: (1) 8 kPa to 15 kPa
(2) 8 kPa or under: with pump

Range:

Select scale range(Span):
General Gas: 30 to 50% of maximum value of the span.

Butane or Butene + Air:
20 to 30% of maximum value of the span.

Propane or Propylene + Air:
25 to 40% of maximum value of the span.

Output: 1 to 5 V DC, 4 to 20 mA DC (simultaneously), non-isolated, load resistance 750 Ω or less

Alarm Contact Output:

Flame off alarm; 100 V AC, 5 A, closed when alarm occurs (resistance load) when contact is opened, the leakage current is 2mA or less (100V AC)

Temperature alarm; 100 V AC, 3 A, closed when alarm occurs (resistance load)

Contact Input:

Remote ignition (Custom order);
24 V DC, 0.1A or more

Repeatability:

Measurement	Measuring range Note 1	Repeatability
WI	High calorific value	±0.5% of measured value
	Low calorific value	±1.0% of measured value
Calorific value MJ/Nm ³	High calorific value	±1.0% of measured value
	Low calorific value	±1.5% of measured value

Note 1: High calorific value means 6.3 MJ/Nm³ or higher.
Low calorific value means below 6.3 MJ/Nm³.

Sample Gas Flow Rate: Approx. 10 l/min

Response Time (Note 2):

Max. WI measured	Dead time	Response Time (63.2%)
50 or more	42 sec or less	70 sec or less
32 or more, less than 50	39 sec or less	60 sec or less
13 or more, less than 32	36 sec or less	50 sec or less
13 or less	30 sec or less	45 sec or less

Note 2: Response time varies depending on the WI of a sample gas. This is due to the different sample gas flow rate of the calorimeter. The flow rate is preset depending on the WI of the sample gas to prevent the calorific value at the detector burner from exceeding the upper limit. When the orifice protective filter is added, the time constant becomes 30 seconds longer.

Utility:

Water: Approx. 0.2 l/min, pressure 200 to 600 kPa
 Instrument Air: Approx. 50 NI/min, pressure 300 to 700 kPa, dew point of 0 °C or less
 Power Supply: 100 V AC \pm 10%, single phase, 50/60 Hz (Note 3), 1100 VA max.

Note 3: In case of low calorific value measurement, frequency variation should be within \pm 0.4%.
 If frequency variation exceeds \pm 0.4%, consult with Yokogawa.

Panel:

Construction: For indoor installation, rack panel.
 Paint Color: Munsell 3.2PB7.4/1.2 (inside and outside).
 Ambient temperature: 0 to 40°C and no rapid change in ambient temperature is allowed.
 Rapid change here means a change of approximately 10°C within 30 minutes.

■ MODEL AND SUFFIX CODE

1. Gas Calorimeter

Model	Suffix Code	Option Code	Description
CM6G	-----	-----	Gas calorimeter
—	-S6	-----	Always - S6
Gas Pressure	1	-----	Gas pressure 10 to 20 kPa for town gas, quake-proof
	2	-----	Gas pressure 10 to 20 kPa for town gas
	3	-----	Gas pressure 10 kPa or under for town gas
	4	-----	Gas pressure 100 to 600 kPa for town gas
	5	-----	Gas pressure 8 kPa to 15 kPa for steel mill, without preheating
	6	-----	Gas pressure 8 kPa to 15 kPa for steel mill, with preheating
	7	-----	Gas pressure 8 kPa or under for steel mill, without preheating
	8	-----	Gas pressure 8 kPa or under for steel mill, with preheating
Measurement	00	-----	WI measurement
	10	-----	Calorific value measurement (GD400G should be purchased separately)
Power supply	-5	-----	100 V AC 50 Hz
	-6	-----	100 V AC 60 Hz
Range	R	-----	Measuring range
Style	*C	-----	Style C

Note: Measuring range and unit must be specified.

2. Standard Accessories

• Calorie Detector

Name	Q'ty	Part No.	Remarks
Mirror	1	E7023FF	
Fuse	2	A1113EF	3.15 A

• Orifice Assembly

Name	Q'ty	Part No.	Remarks
O-Ring	1	Y9114XB	P16 (Viton)
O-Ring	3	L9817MT	P20 (Silicon)
Hexagon Wrench	1	L9827AB	Nominal size 1.5 mm
Hexagon Wrench	1	L9827AC	Nominal size 2.5 mm

3. Density Meter

Gas Density Meter is required for density compensation in calorific value measurement.
 It is not required for WI measurement.

Converter: GD400G-N-10-N-□/PA

Detector: GD300S-J-□/KU

Measuring range and unit (specific gravity or density) should be specified.

4. Option

Name	Part no.	Description
Probe	H7800HA	Insertion length 650 mm
Probe	H7800HB	Insertion length 1150 mm
Probe	H7800HC	Insertion length 1650 mm
Fulfilo filter	G7043XJ	Element material: Polypropylene Pore size: 50 μ m, Body: SUS 316, Connection: Rc 1/2
Pressure reducing valve	G7008XF	Primary pressure: 15 MPa max. Secondary pressure: 0 to 200 kPa, Material: Brass

EXTERNAL DIMENSIONS

1. For Town Gas Application

CM6G-S6200, S6210, S6300, S6310, S6400, S6410

Unit: mm

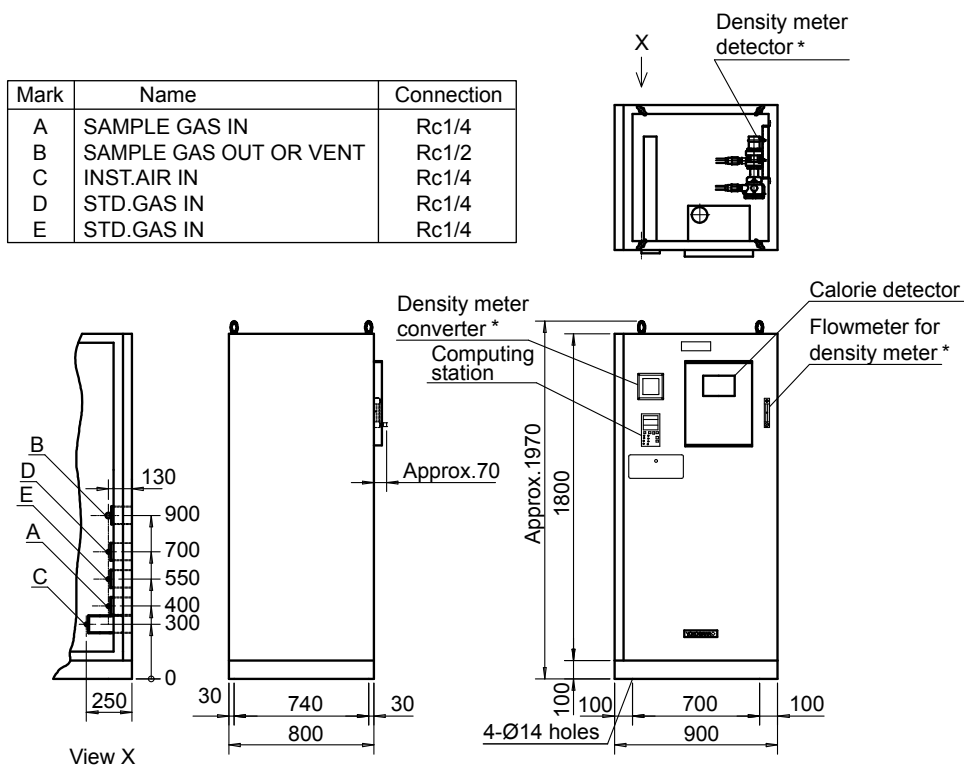

* CM6G-S6□10 (with density meter) only

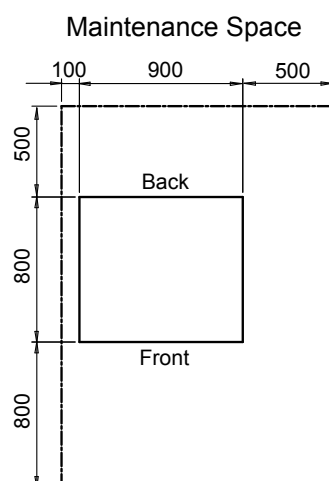

Weight: Approx. 300kg

Dim-6210.ai

2. For Town Gas Application (Quake-proof Type)

CM6G-S6110

Unit: mm

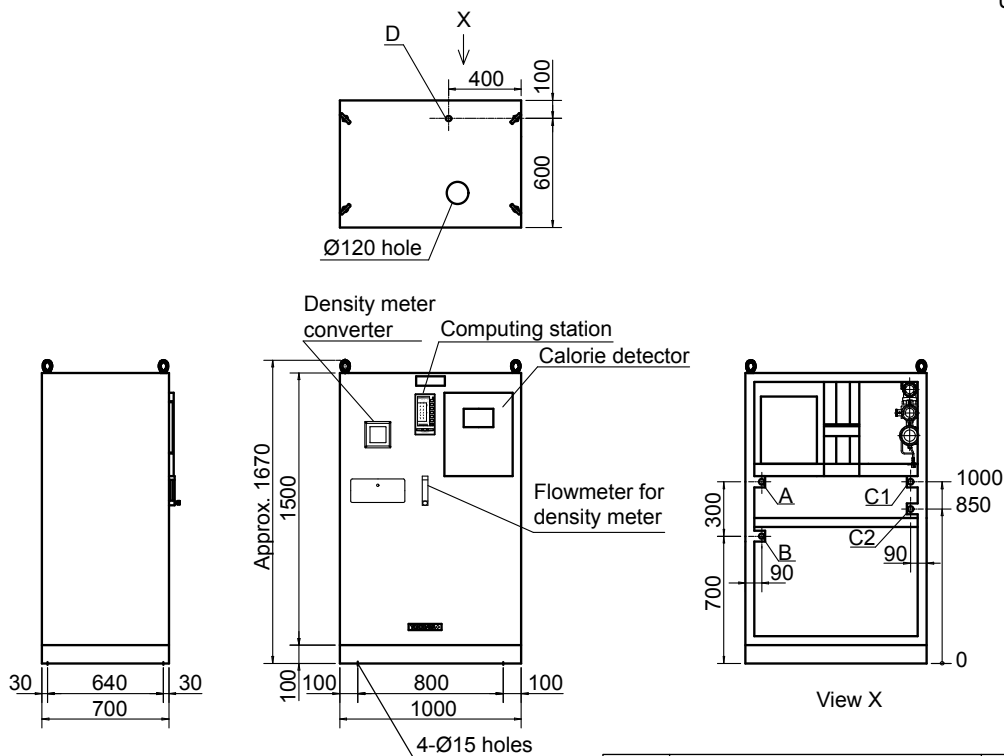

Mark	Name	Connection
A	SAMPLE GAS IN	Rc1/4
B	INST.AIR IN	Rc1/4
C1	STD.GAS IN (ZERO)	Rc1/4
C2	STD.GAS IN (SPAN)	Rc1/4
D	SAMPLE GAS OUT OR VENT	Rc1/2

Wiring to switch box should be made through the bottom.

Maintenance Space

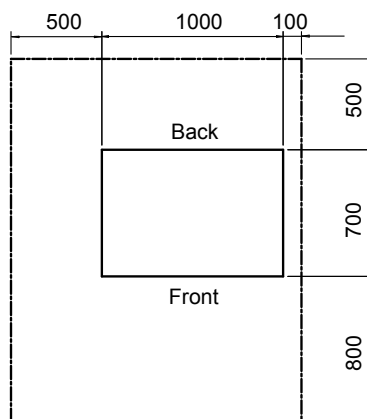

Weight: Approx. 350kg

Dim-6110.ai

3. For Steel Mill Application

CM6G-S6500, S6510, S6600, S6610, S6700, S6710, S6800, S6810

Unit: mm

Mark	Name	Connection
A	SAMPLE GAS IN	Rc1/2
B	SAMPLE GAS OUT	Rc1/2
C	SAMPLE GAS OUT	Rc1/2
D	STD.GAS IN	Rc1/4
E	WATER IN	Rc1/2
F	DRAIN OUT	Rc1/2
G	INST.AIR IN	Rc1/4
H	SAMPLE GAS VENT	Rc1/4

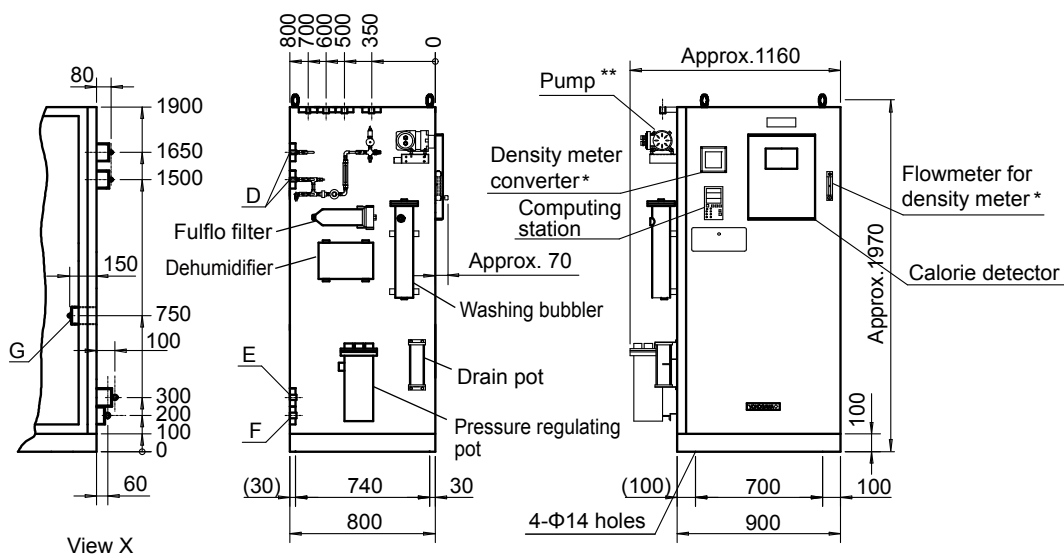
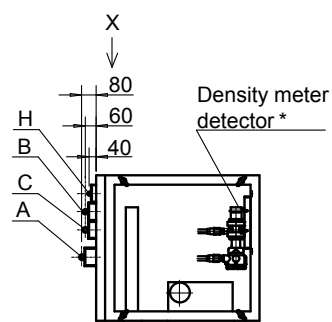

* CM6G-S6□10 (with density meter and flowmeter)
 ** CM6G-S67□0, CM6G-S68□0 (with pump)

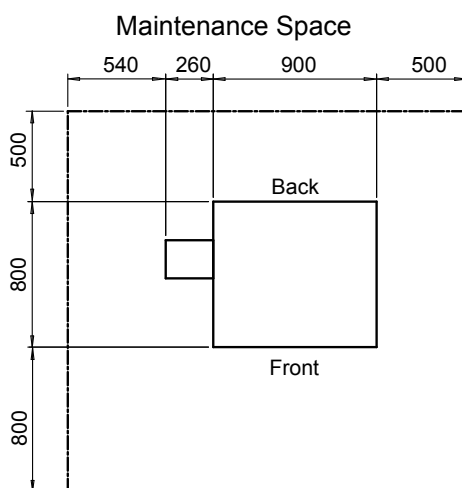

Weight: Approx. 350kg

Dim-6810.ai

■ Dimensions of Options

1. Probe

Unit: mm

Part number	L
H7800HA	Approx. 650
H7800HB	Approx. 1150
H7800HC	Approx. 1650

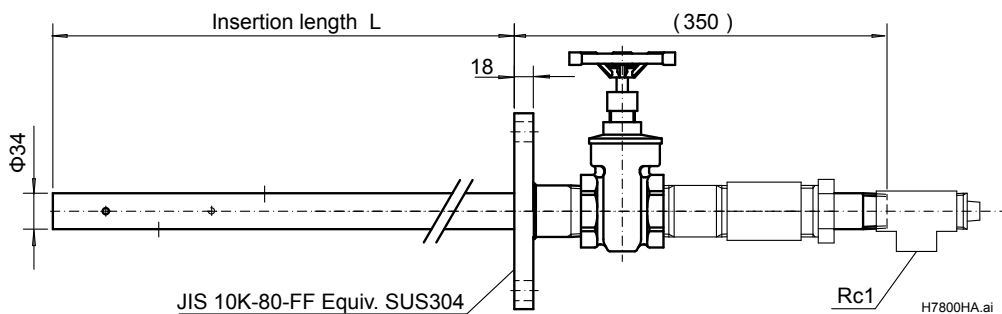

2. Fulflo Filter (Part no.: G7043XJ)

Unit: mm

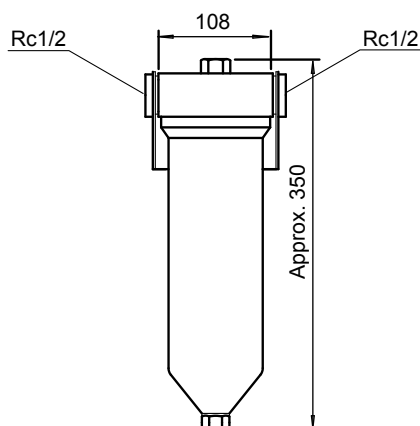

3. Pressure Reducing Valve (Part no.: G7008XF)

Unit: mm

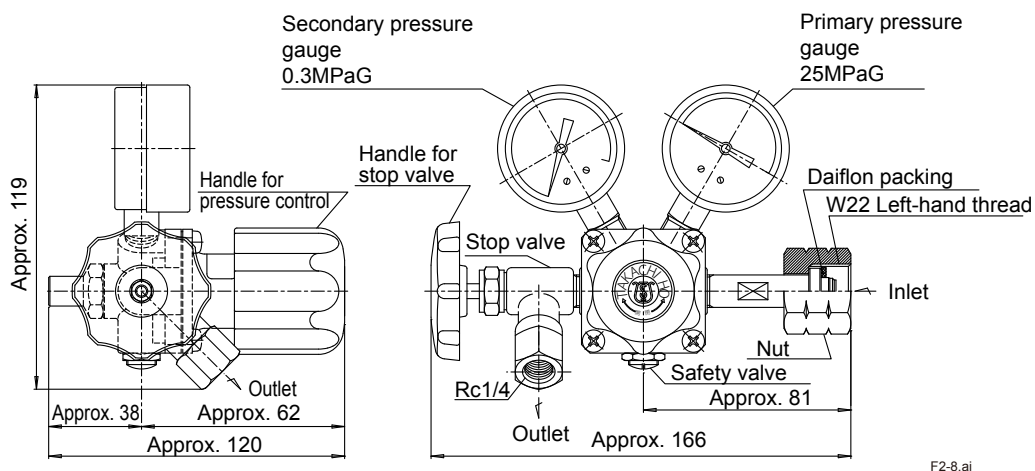

■ Standard Systems for Each Application

Application	Measurement	System specification		Suffix code*
Town Gas	WI	Without density meter	Gas pressure 10 to 20 kPa Gas pressure 10 kPa or under: With pump Gas pressure 100 to 600 kPa: With pressure reducing valve	-S6200 -S6300 -S6400
	Calorific value MJ/Nm ³	With density meter	Gas pressure 10 to 20 kPa: Quake-proof Gas pressure 10 to 20 kPa Gas pressure 10 kPa or under: With pump Gas pressure 100 to 600 kPa: With pressure reducing valve	-S6110 -S6210 -S6310 -S6410
Steel Mill	WI	Without density meter	Gas pressure 8 to 15 kPa : Without preheating Gas pressure 8 to 15 kPa : With preheating Gas pressure 8 kPa or under: Without preheating Gas pressure 8 kPa or under: With preheating	-S6500 -S6600 -S6700 -S6800
	Calorific value MJ/Nm ³	With density meter	Gas pressure 8 to 15 kPa : Without preheating Gas pressure 8 to 15 kPa : With preheating Gas pressure 8 kPa or under: Without preheating Gas pressure 8 kPa or under: With preheating	-S6510 -S6610 -S6710 -S6810

*: Corresponding Suffix Code of "-S6", gas pressure and measurement.

Note: A wet sample gas in the town gas application is outside the scope of the standard specifications. Consult with Yokogawa.

■ Instructions for System Selection

- (1) The quake-proof type gas calorimeter is always equipped with the density meter.
- (2) The CM6G Gas Calorimeter controls the flow rate under a constant differential pressure. In the calorific value measurement, if the density of a sample gas changes, a flow rate error proportional to the reciprocal of the square root of the density of the sample gas, $1/\sqrt{\rho_g}$, will be generated, which directly affects the calorific value. Therefore, density compensation is required using a density meter.
For the WI measurement, a density meter is not required since the WI is a value proportional to $1/\sqrt{\rho_g}$.

■ Standard Flow Sheet

1. Town Gas Application (Standard Type)

CM6G-S6200, S6210, S6300, S6310, S6400, S6410

No.	Item	No.	Item	No.	Item
1-1	Calorie detector	3-1	Line filter	5-1	Density meter detector (when specified)
1-2	Solenoid valve	3-2	Pressure gauge	5-2	Density meter converter (when specified)
1-3	Orifice assembly	3-3	Flowmeter	5-3	Flowmeter for density meter (when specified)
1-4	Differential pressure transmitter (air)	3-4	Pressure reducing valve	6-1	Standard gas cylinder (supplied by customer)
1-5	Differential pressure transmitter (gas)	3-5	Pressure gauge	6-2	Standard gas cylinder (supplied by customer)
1-6	Computing station	3-6	Pressure reducing valve	7-1	Pressure reducing valve for cylinder (optional)
2-1	Air set	3-7	Diaphragm pump (when specified)	7-2	Pressure reducing valve for cylinder (optional)
2-2	Pressure reducing valve	3-8	Pressure reducing valve (when specified)	V1...16	Ball valve, needle valve
2-3	Pressure gauge	4-1	Pressure reducing valve		
2-4	Preheating chamber				
2-5	One touch coupler				

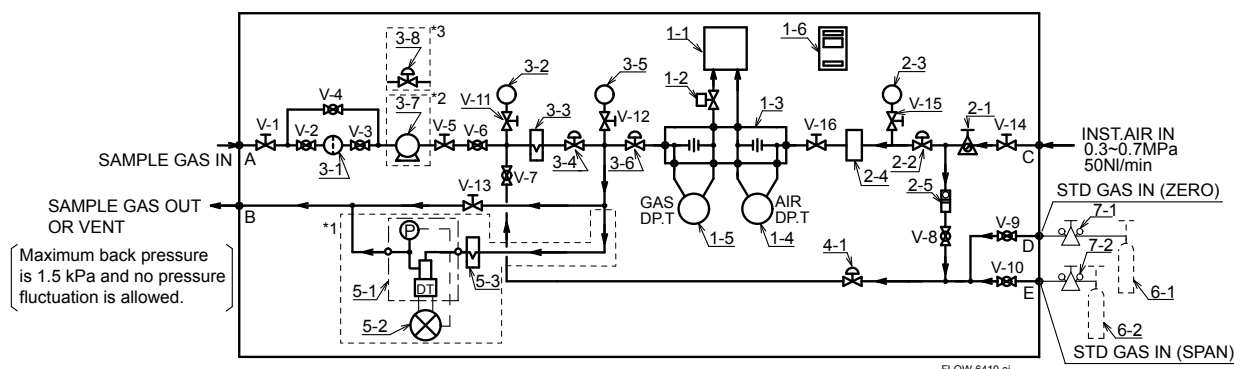

- *1: CM6G-S6□10 (with density meter)
 *2: CM6G-S63□0 (with diaphragm pump)
 *3: CM6G-S64□0 (with pressure reducing valve)

2. Town Gas Application (Quake-proof Type)

CM6G-S6110

No.	Item	No.	Item	No.	Item
1-1	Calorie detector	3-1	Line filter	6-1	Standard gas cylinder (supplied by customer)
1-2	Solenoid valve	3-2	Pressure gauge	6-2	Standard gas cylinder (supplied by customer)
1-3	Orifice assembly	3-3	Flowmeter	7-1	Pressure reducing valve for cylinder (optional)
1-4	Differential pressure transmitter (air)	3-4	Pressure reducing valve	7-2	Pressure reducing valve for cylinder (optional)
1-5	Differential pressure transmitter (gas)	3-5	Pressure gauge	V1...16	Ball valve, needle valve
1-6	Computing station	3-6	Pressure reducing valve		
2-1	Air set	4-1	Pressure reducing valve		
2-2	Pressure reducing valve	5-1	Density meter detector		
2-3	Pressure gauge	5-2	Density meter converter		
2-4	Preheating chamber	5-3	Flowmeter for density meter		
2-5	One touch coupler				

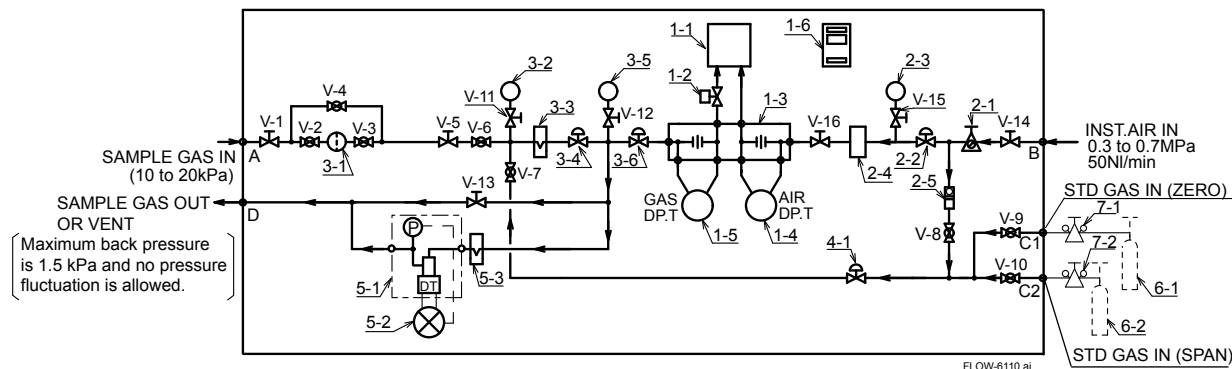

3. Steel Mill Application

CM6G-S6500, S6510, S6600, S6610, S6700, S6710, S6800, S6810

No.	Item	No.	Item	No.	Item
1-1	Calorie detector	3-1	Pressure gauge	5-1	Density meter detector (when specified)
1-2	Solenoid valve	3-2	Washing bubbler	5-2	Density meter converter (when specified)
1-3	Orifice assembly	3-3	Fulfo filter	5-3	Flowmeter for density meter (when specified)
1-4	Differential pressure transmitter (air)	3-4	Pressure regulating pot	6-1	Water Flowmeter
1-5	Differential pressure transmitter (gas)	3-5	Dehumidifier	7-1	Probe (optional)
1-6	Computing station	3-6	Pressure reducing valve	7-2	Fulfo filter (optional)
2-1	Air set	3-7	Line filter	9-1	Pressure reducing valve for cylinder (optional)
2-2	Pressure reducing valve	3-8	Diaphragm pump (when specified)	9-2	Pressure reducing valve for cylinder (optional)
2-3	Pressure gauge	3-9	Drain pot (when specified)	10-1	Standard gas cylinder (supplied by customer)
2-4	Preheating chamber	4-1	Pressure reducing valve for cylinder	10-2	Standard gas cylinder (supplied by customer)
2-5	One touch coupler	4-2	Flowmeter	11-1	Seal pot (supplied by customer)
				V1...16	Ball valve, needle valve

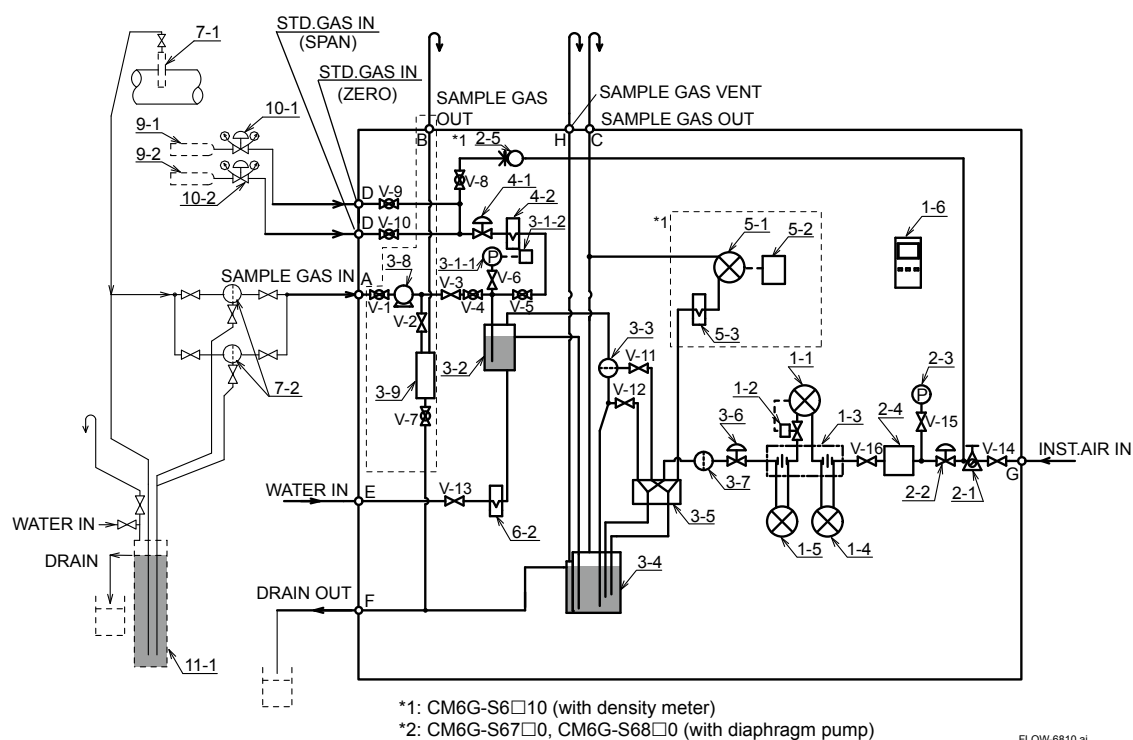

■ Installation Procedures

Installation Site

- (1) Adequate space for maintenance should be provided around the gas calorimeter.
- (2) The base should be horizontal.
- (3) Ambient temperature is 0 to 40°C and no rapid change in ambient temperature is allowed. Rapid change here means a change of approximately 10°C within 30 minutes.
- (4) Install the instrument in the place where it is not directly exposed to the current of a conditioned air.
- (5) Minimal vibration is allowed (If much vibration is unavoidable, take an appropriate measure to absorb shock, e.g. use of vibration-proof rubber).
- (6) A ventilation system should be provided.
- (7) Corrosive gases and dust are present in small quantities and humidity is low.
- (8) The water of the sampling system and the drain line do not freeze up.

Installation of the Optional Probe (Reference)

- (1) The open probe should be installed at an angle that does not allow drain generated at the probe outlet to flow back into the probe.
- (2) Steam piping should be installed, if necessary, to prevent drain from freezing.
- (3) Steam piping for probe blowback should be installed, if necessary.
- (4) Safe space for maintenance should be considered.

Installation of the Seal Pot (Reference)

The seal pot should be positioned so that drain generated in the sample gas between the probe and the seal pot flows into the seal pot.

Others (Reference)

Calibration gas cylinders for the gas calorimeter should be installed and connected. Calibration gas cylinders are heavy, so they should be installed in a place allowing easy replacement. The installation place should also be as close to the gas calorimeter as possible.

Wiring Work

- (1) Use conduits for power and other wiring.
- (2) Select the appropriate nominal conductor size of the power line based on the power consumption and wiring distance. For example, if the power consumption is 200 VA, the one-way resistance of the wire should be within 1.25 Ω. (If a wire with a nominal size of 1.25 mm² is used, the maximum wiring distance is 75 m.)
- (3) Upon completing the wiring to the calorimeter, make sure that the wiring is made correctly.
- (4) For ground wiring, use an insulated wire with a nominal size of at least 2 mm². The ground resistance should be 100 Ω or less (JIS Class D grounding).
- (5) For signal wiring, use insulated wires. Wiring work should be appropriately done in accordance with the wiring distance and allowable load resistance.

Piping Work

- (1) Before the piping to the gas calorimeter, wash the inside of the pipes to remove oil, dust and other impurities, and dry it.
- (2) After the piping, be sure to perform a leak test applying a pressure greater than the operating pressure.
- (3) Sample gas may contain dangerous gases such as combustible gas, oxygen-depleted gas, and toxic gas. The gas should be safely discharged through vent pipes in accordance with local regulations. (In principle, the pressure of the discharge point is atmospheric pressure.)
- (4) Instrument air to be used must be clean and dehumidified. After installing the pipe for instrument air, make sure that the inside is not stained.
- (5) After installing pipes for standard gases, make sure that the inside is not stained.
- (6) Bent the outlet of the blow piping as shape U, and prevent it from the rain penetration. Set the location of the outlet at higher position as much as possible where there is little fear of danger.
- (7) Drain piping shall be conducted so that it stays below the drain outlet and no drain accumulated on the panel bed.
- (8) It is necessary for the sample line of the steel mill use instrument to provide a slope of more than 1/3, so that there happens no blockade to the gas line by the drain at the bending part of the piping. Make piping as short as possible. Equip the sample line with thermal insulation so as to prevent drain in the pipe line to be freezed.

- (9) Locate the standard gas cylinders at the place where they are not exposed to direct sunshine and comparatively cool.

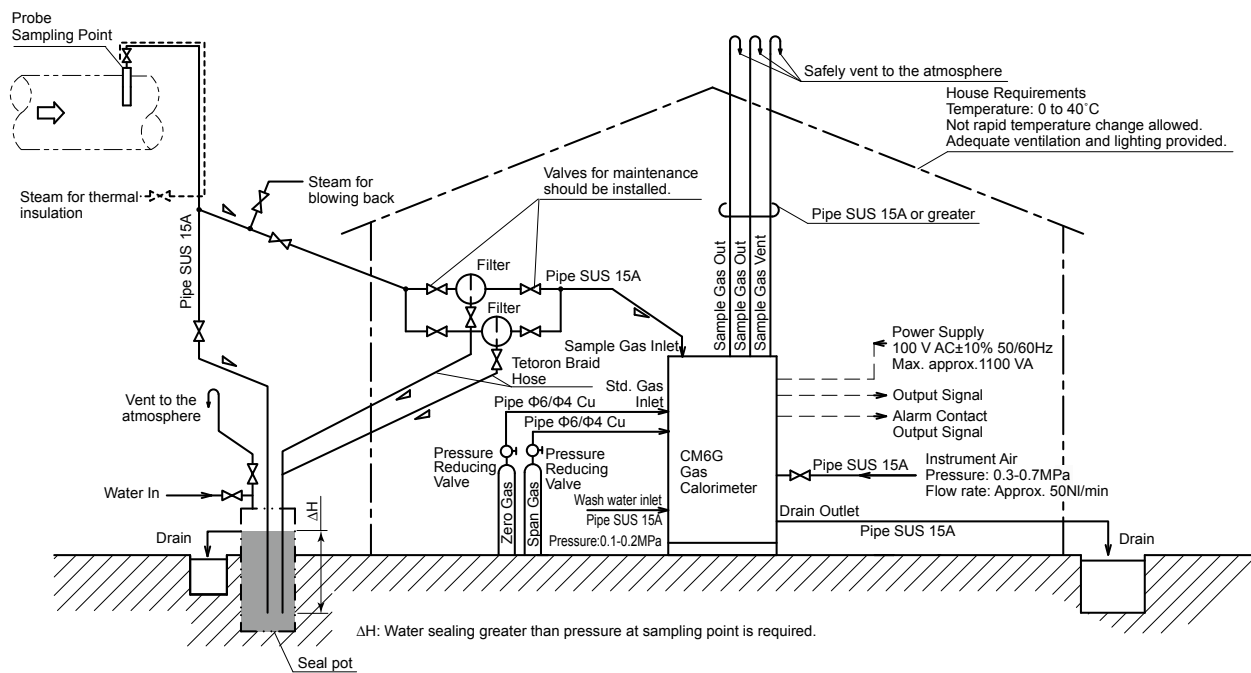

Note: ↘ denotes that piping should be installed at an angle that allows drain to flow downstream and smoothly.

F4-1.ai

GAS CALORIMETER ENQUIRY SHEET

Thank you for enquiring about our gas calorimeter. Please specify your requirements by making checks in each applicable and writing in the underlined parts.

1. General Information

Customer: _____ Contact person: _____ Sect: _____ (phone: _____)
 Name of plant: _____
 Measuring point: _____
 Purpose: measurement control alarm trading
 Power supply: 100 V AC 50 Hz 60 Hz

2. Process Conditions

Sample gas: town gas fuel gas in steel plant
 Measurement: WI calorific value
 Measuring range: _____ to _____ (specify in the range of 3 to 62 MJ/Nm³)
 Gas pressure: For town gas
 10 to 20 kPa 10 kPa or under 100 to 600 kPa
 For steel plant
 8 to 15 kPa 8 kPa or under
 Gas temperature: _____ to _____ °C (normally _____ °C)
 Gas humidity: dew point _____ °C
 Dust content: No dust Little Much _____ to _____ g/Nm³
 Gas composition:

Gas composition	Nor %	Max %	Min %	Gas composition	Nor %	Max %	Min %
H ₂				CO			
CH ₄				CO ₂			
C ₂ H ₄				N ₂			
C ₂ H ₆							
C ₃ H ₈							
C ₄ H ₁₀							

Others:

3. Installation

Ambient temperature: _____ to _____ °C
 Vibration: NO YES
 Others:

4. Specification Requirements

Measuring range: _____
 Output: 1 to 5 V DC, 4-20 mA DC (simultaneously)
 With gas density meter: YES NO
 Others: