

# User's Manual

## Model ND230 Ao/DeviceNet Converter

IM 77P01L01-01E

Thank you for purchasing the ND230 Ao/DeviceNet Converter. For the correct use of this product, read through this manual before use.  
This user's manual should be kept in safety place.

**YOKOGAWA**  
Yokogawa Electric Corporation

IM 77P01L01-01E  
2nd Edition; Jun. 01, 2004

### 1. CAUTIONARY NOTES FOR SAFE USE OF THE PRODUCT

The following safety symbol is indicated on the product and the manual to ensure safe use.

#### CAUTION

If this symbol is indicated on the product, the operator should refer to the explanation given in the user's manual in order to avoid personnel injury or death to either themselves or other personnel, and/or damage to the instrument. The manual describes the special care that the operator should exercise to avoid or other dangers that may result in injury or loss of life.

The following symbol marks are used only in this manual.

#### IMPORTANT

Indicates that operating the hardware or software in particular manner may damage it or result in system failure.

#### NOTE

Draws attention to information that is essential for understanding the operations and/or features of the product.

### 2. GENERAL

The Model ND230 Ao/DeviceNet Converter receives 16 points of digital signals (0 to 10000) via DeviceNet unit from PLCs (such as OMRON Corporation's SYSMAC PLCs and Yokogawa Electric Corporation's FA-M3 etc.), converts them to analog outputs signals (1 to 5 V DC) for the inputs of signal converter-(Yokogawa Electric Corporation's D Series), and couples with the signal converter via a dedicated cable.

Note: When ordering, the scaling of -30000 to 30000 for digital signals can be specified.

### 3. PREPARATION BEFORE OPERATION

Prepare following items before operation.

1. ND230 (required number)
2. NA200 (required number of cables for network signal converters; separate order for relative accessories)
3. Exclusive cables for connection between ND230 and DeviceNet (required number)
4. Power line (refer to the followings)

Parts name	Specifications
Power line/grounding wire	600 V vinyl isolated wire JIS3307 0.9 to 2.0 mm <sup>2</sup>

### 4. NAMES AND FUNCTIONS OF FRONT-PANEL

#### <1> Operating condition indicator LED (RDY)

light on (green): normal  
light on and off (green): abnormal  
light off : none the power supply

#### <2> Operating condition indicator LED (MS)

light on (green): normal  
light on and off (green): setting not complete (under read-in of switch settings)  
light on (red): fatal failure (any of abnormal watch-dog timer, memory failure or system failure), necessary to exchange unit.

light on and off (red) : light miss (any of abnormal configuration, incorrect switch setting, failure initial setting with PC, abnormal PC interface or abnormal routine table), enable recovery with re-setting and so on.

light off : none the power supply or reset condition

#### <3> Operating condition indicator LED (NS)

light on (green): complete communication connection  
light on and off (green): not complete communication connection (not established of remote I/O or message connection)  
light on (red) : fatal failure (duplicate of node address or detect Busoff)  
light on and off (red) : light communication abnormal (any of abnormal communication, abnormal configuration or abnormal verify)  
light off : not on-line condition

#### <4> Output connector (CN2)

Connector for analog output signals

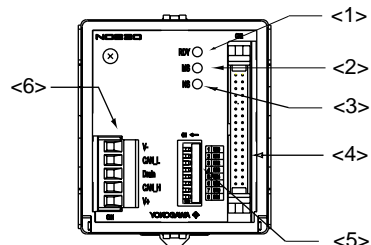

### ■ Checking Product Specifications and Contents of Packing

#### (1) Model Number and Suffix Code Check

Check that the model number and suffix code shown on the nameplate attached on the right side of the product are as ordered.

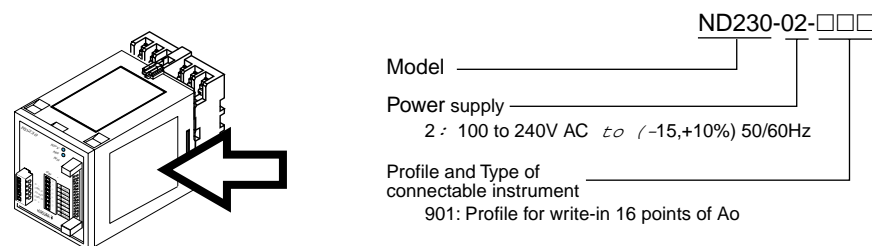

#### (2) Contents of the Packing Check

Check that the packing contains the following items.

- ND230 main unit : one
- User's Manual (this book: IM 77P01L01-01E) : one

#### <5> Setting switch

Setting of node address and communication speed (all 0 when shipping)

##### NA0 to NA5 Node address switch

Node address	Dip switch					
	NA5	NA4	NA3	NA2	NA1	NA0
0	0	0	0	0	0	0
1	0	0	0	0	0	1
2	0	0	0	0	1	0
3	0	0	0	0	1	1
:	:	:	:	:	:	:
62	1	1	1	1	1	0
63	1	1	1	1	1	1

(0 : OFF, 1 : ON)

##### DR0 to DR1 Communication speed setting switch

Setting of switch		Communication speed	Network maximum length	Branch length	Total branch length
DR1	DR0				
OFF	OFF	125 kbit/s	500 m	6 m or less	156 m or less
OFF	ON	250 kbit/s	250 m		78 m or less
ON	OFF	500 kbit/s	100 m	---	39 m or less
ON	ON	not settable	---		---

#### <6> Communication connector (CN1)

Connector for the connection of dedicated DeviceNet cable

#### IMPORTANT

One ND230 converter occupies 24 channels. Therefore keep attention to the number that is assigned to the DeviceNet unit (master unit). For detail refer to the manuals that master unit specify

### 5. DIMENSIONS

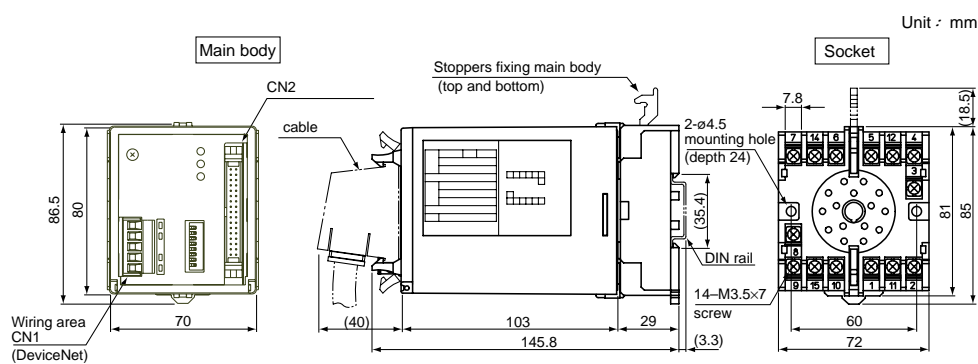

Note : CN1: Connector for DeviceNet connection  
CN2: Connector for analog outputs

### 6. MOUNTING METHODS

#### ● Wall mounting

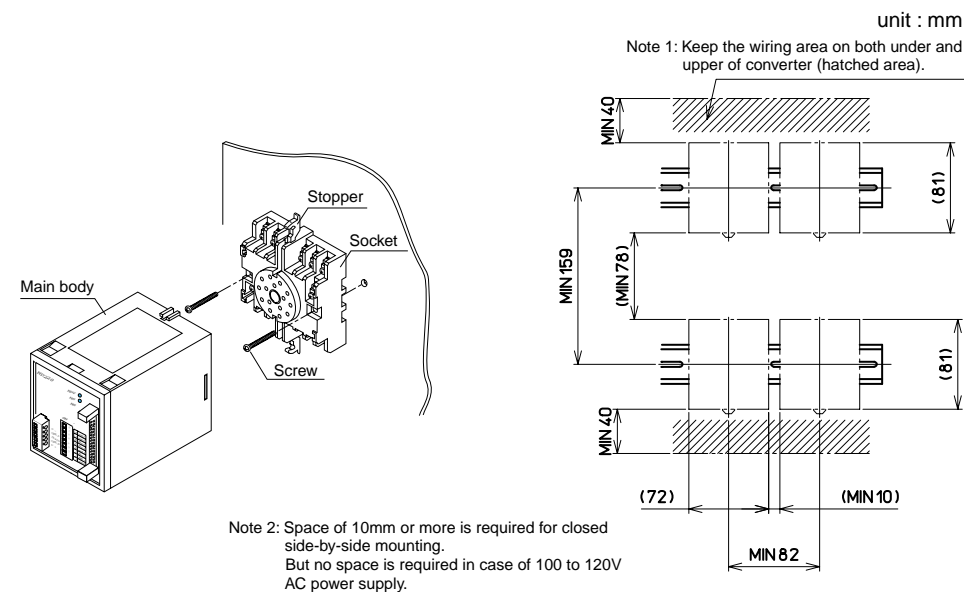

Fig.6-1 Wall mounting

Fig.6-2 Mounting dimensions

Unlock the stoppers (top and bottom), and pull out the main body from the socket. Then fix the socket on wall with two M4 screws. Insert the main body to the socket and fix the body with stoppers (top and bottom).

● DIN rail mounting

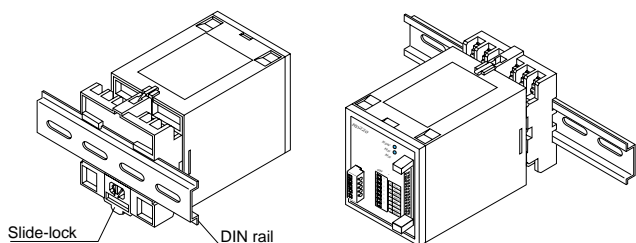

Fig.6-3 DIN rail mounting

Insert DIN rail into the upper portion of the DIN rail groove at rear of socket of the converter and fix the converter to the DIN rail with slide-lock at the lower of the converter.

**7. INSTALLATION LOCATION**

- (1) Avoid installation in such environments as follows.
  - The place to be exposed to the corrosive gas -such as sulfide gas - or sea breeze
  - The place where the visible dust exist
  - The place to be exposed to the direct sunlight
- (2) If there is a possibility that lightning could induce a high surge voltage on the power and signal lines, provide dedicated lightning arrestors for each sides on the lines between the field instrument and indoor instrument in order to protect the product.

**8. EXTERNAL WIRING**

**CAUTION**

Before carrying out wiring, turn off the power to the converter, and check that the cables to be connected are not alive with the tester or the like because there is a possibility of electric shock. Wiring must be carried out by persons who have basic electrical knowledge and practical experience.

Wires are connected to the terminals of the ND230 converter's socket. M3.5 screw terminals are provided for the connection of external signals. Flexible twisted wires and good contact of durable round crimp-on terminals are recommended for use.

**IMPORTANT**

- After wiring, check the model and specifications of the ND230 converter's body to be inserted to the socket for no-miss matching. If incorrect unit is inserted, we can't guarantee the operation.
- It may be damage for instrument if the power line is miss wiring.
- Power line and communication lines must be separated from noise occurrences. If so, we may not be guarantee.
- The other terminals excepting power line terminals should not be connected for other inter-connection terminals.

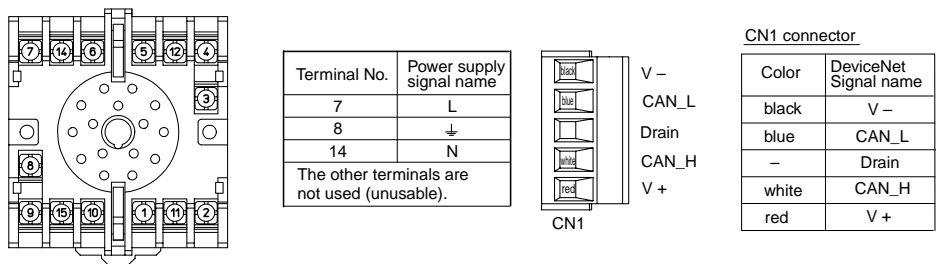
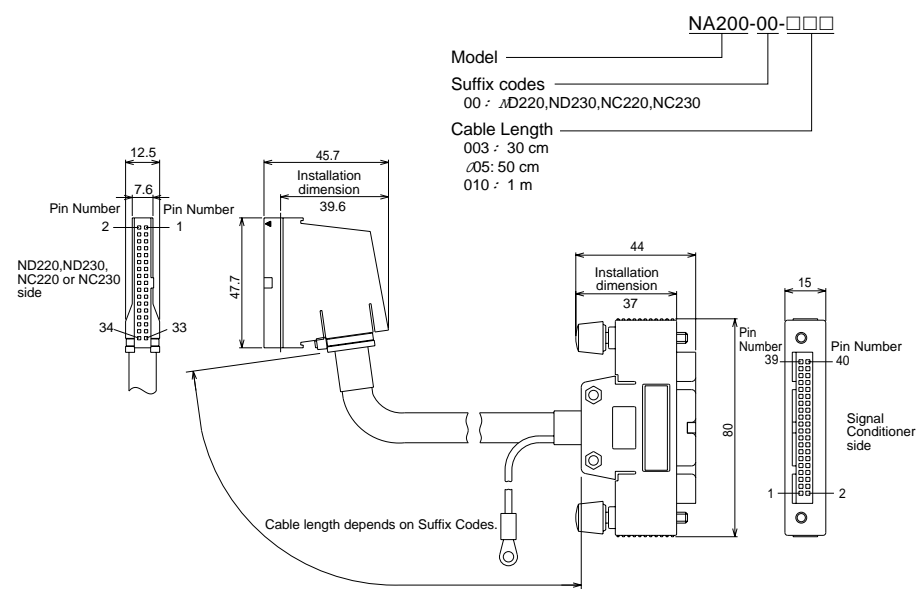

Fig.8-1 Terminal Arrangement

**9. CABLE FOR NETWORK INSTRUMENT (NA200)**



Adaptable Model	Connectable Signal Converter	Adaptable Nest Model
ND230	D series	DCE3□*3,DCP3□*3

**10. TRABLE SHOOTING**

The followings explain basic trouble shooting methods for the ND230 usage. Refer to the respective user's manuals for the SEQUENCE CPU and the master unit.

● MS (Green : light on), NS : (light off)

Under conditions	Recovery Methods
Waiting for the completion of duplicate node address check by the master unit.	When the specific slave is in those conditions, check that the transmission speed is same or not, and restart the unit.

● MS (Green : light on), NS : (green : light on and off)

Check items	Recovery Methods
Waiting for the completion of connection by the master unit.	

● MS (Red : light on), NS : (light off)

Under conditions	Recovery Methods
Occurrence abnormal watch-dog timer in slave	Exchange the specific slave.

● MS (Red : light on and off), NS : (light off)

Under conditions	Recovery Methods
Incorrect switch setting such as dip switch	After checking the dip switch setting, restart the slave.

● MS (Green : light on), NS (Red : light on)

Under conditions	Recovery Methods
Under Busoff condition (Stopping communication due to too many of the communication errors)	Check the followings, and restart the slave. <ul style="list-style-type: none"> <li>• The transmission speeds of master and slaves are same.</li> <li>• The cable length is adequate (for both main line and branch line).</li> <li>• There is no cable disconnection or loose.</li> <li>• The terminator resistors are set for both end side of main line.</li> <li>• There is too much noise.</li> </ul>

● MS (Green : light on), NS : (Red : light on and off)

Under conditions	Recovery Methods
Under condition of transmission time out	Same as when MS (Green : light on), and NS (Red : light on)

● MS (Green : light on), NS : (Green : light on)

Under conditions	Recovery Methods
Normal DeviceNet communication	Remote I/O communication is good. Check the RS485 communication lines which are incorrect - such as disconnection, broken line, influence of noise, miss setting of connected instrument.

**11. PROFILE**

Please write in the output data as following procedure.

[PROCEDURE]

- (1) Read out Remote READY Flag [bit B of 17ch. (hex) in IN AREA]. And check that it is [1].
- (2) Write in the required data to (0 to F) CH. (hex) in OUT AREA.

REMOTE I/O

	IN AREA	Contents	OUT AREA	Contents
← No.1 output	0 (HEX)		0 (HEX)	No.1 Output setting data
← No.2 output	1		1	No.2 Output setting data
← No.3 output	2		2	No.3 Output setting data
← No.4 output	3		3	No.4 Output setting data
← No.5 output	4		4	No.5 Output setting data
← No.6 output	5		5	No.6 Output setting data
← No.7 output	6		6	No.7 Output setting data
← No.8 output	7		7	No.8 Output setting data
← No.9 output	8		8	No.9 Output setting data
← No.10 output	9		9	No.10 Output setting data
← No.11 output	A		A	No.11 Output setting data
← No.12 output	B		B	No.12 Output setting data
← No.13 output	C		C	No.13 Output setting data
← No.14 output	D		D	No.14 Output setting data
← No.15 output	E		E	No.15 Output setting data
← No.16 output	F		F	No.16 Output setting data

● Output setting data — Area for write in —

The output setting data are converted to analog output signals, and the analog output signals are coupled with signal converter — D series — via a dedicated cable .

(Output setting range : -32767 to +32767)

The scale range of the Output setting data to be converted to analog output signals is 0 to 10000 in default when ordering, for shipping.

[For example] When the scale range is 0 to 10000, and a analog output value is required 3V, write in [5000] in OUT AREA of Remote I/O.

**12. MAINTENANCE**

The ND230 main body can be removed from the socket under operating in case of exchange or maintenance of the converter. However before removing the main body of the converter, remove the DeviceNet communication cable.

**CAUTION**

After remove DeviceNet connector from the main body, carry out the maintenance of the converter. There is a possibility of electric shock, so be careful not to touch the terminals of the socket when the ND230 main body is removed from the socket under operating condition.

### 13. DEVICE PROFILE AND OBJECT IMPLEMENTATION

#### Device Profile

General Device Data	Conforms to DeviceNet Specification	Volume 1 Release2.0 Volume 2 Release2.0
	Vendor ID	301(Yokogawa M&C Corporation)
	Device Profile Name	0(Generic)
	Product Catalog Number	1:ND210, 2:ND220, 3:ND230
Physical Conformance Data	Network Power Consumption	55 mA
	Connector Style	Open Pluggable
	Isolated Physical Layer	Yes
	LEDs Support	Module Network
	Mac ID Setting	Dip Switch
	Default Mac ID	0
	Communication Rate Setting	Dip Switch
Communication Data	Communication Rates Supported	125 kbit/s, 250 kbit/s, 500 kbit/s
	Predefined Master/Slave Connection Set	Group 2 Only Server
	Dynamic Connections Supported (UCMM)	No
	Fragmented Explicit Messaging Implemented	Yes

#### Object Implementation

##### Identity Object (Class ID: 01H)

Object Class	Attributes	None supported
	Services	None supported

Object Instance	Attributes	ID	Description	Get	Set	Value Limit
		1	Vendor	○	×	301
		2	Product type	○	×	0
		3	Product code	○	×	*1
		4	Revision	○	×	1.06
		5	Status(bits supported)	○	×	bit 0, bit 10
		6	Serial number	○	×	Set for Every Unit
		7	Product name	○	×	*1
		8	State	×	×	
		9	Configuration Consistency Value	×	×	
		10	Heartbeat Interval	×	×	
	Services	DeviceNet Services		Parameter Options		
		05H	Reset	None supported		
		0EH	Get_Attribute_Single	None supported		

*1 Model	Product code	Product name
ND210	1	ND210 -02-***
ND220	2	ND220 -02-801
ND230	3	ND230 -02-901

Mark"\*\*\*\*" depend on Profile1

##### Message Router Object (02H)

Object Class	Attributes	None supported
	Services	None supported
Object Instance	Attributes	None supported
	Services	None supported
Vender Specific Additions		No

##### DeviceNet Object (03H)

Object Class	Attributes	ID	Description	Get	Set	Value Limit
		1	Revision	○	×	02H
	Services	DeviceNet Services		Parameter Options		
		0EH	Get_Attribute_Single	None Supported		

Object Instance	Attributes	ID	Description	Get	Set	Value Limit
		1	Mac ID	○	×	
		2	Baud rate	○	×	
		3	BOI	○	×	00H
		4	Bus-off counter	○	×	
		5	Allocation information	○	×	
		6	Mac ID switch changed	×	×	
		7	Baud rate switch changed	×	×	
		8	MAC ID switch value	×	×	
		9	Baud rate switch value	×	×	
	Services	DeviceNet Services		Parameter Options		
		0EH	Get_Attribute_Single	None supported		
		4BH	Allocate Master/Slave Connection Set	None supported		
		4CH	Release Master/Slave Connection Set	None supported		

##### Assembly Object (04H)

Object Class	Attributes	None supported
	Services	None supported

Object Instance 1	Section	Information		Max. Instance		
		Instance Type	Static I/O	1		
	Attributes	ID	Description	Get	Set	Value Limit
		1	Number of Members in List	×	×	
		2	Member List	×	×	
		3	Data	○	○	
	Services	DeviceNet Services		Parameter Options		
		0EH	Get_Attribute_Single	None supported		
		10H	Set_Attribute_Single	None supported		

#### Connection Object (05H)

Object Class	Attributes	None supported
	Services	None supported
Total Active Connection Possible		1

Object Instance 1	Section	Information		Max. Instance		
		Instance Type	Explicit Message	1		
		Production Trigger	Cyclic			
		Transport Type	Server			
		Transport Class	3			
	Attributes	ID	Description	Get	Set	Value Limit
		1	State	○	×	
		2	Instance type	○	×	00H
		3	Transport class trigger	○	×	83H
		4	Produced connenction ID	○	×	
		5	Consumed connection ID	○	×	
		6	Initial comm. Characteristics	○	×	21H
		7	Produced connection size	○	×	FE00H
		8	Consumed connection size	○	×	FE00H
		9	Expected packed rate	○	○	
		12	Watchdog time-out action	○	○	One of 01, 03
		13	Produced connection path length	○	×	0000
		14	Produced connection path	○	×	
		15	Consumed connection path length	○	×	0000
		16	Consumed connection path	○	×	
		17	Production inhibit time	○	×	
	Services	DeviceNet Services		Parameter Options		
		05H	Reset	None supported		
		0EH	Get_Attribute_Single	None supported		
		10H	Set_Attribute_Single	None supported		

Object Instance 2	Section	Information		Max. Instance		
		Instance Type	Polled I/O	1		
		Production Trigger	Cyclic			
		Transport Type	Server			
		Transport Class	2			
	Attributes	ID	Description	Get	Set	Value Limit
		1	State	○	×	
		2	Instance type	○	×	01H
		3	Transport class trigger	○	×	82H
		4	Produced connenction ID	○	×	
		5	Consumed connection ID	○	×	
		6	Initial comm. Characteristics	○	×	01H
		7	Produced connection size	○	×	3000H
		8	Consumed connection size	○	×	3000H
		9	Expected packed rate	○	○	
		12	Watchdog time-out action	○	×	00
		13	Produced connection path length	○	×	0600H
		14	Produced connection path	○	×	20_04_24_01_30_03
		15	Consumed connection path length	○	×	0600H
		16	Consumed connection path	○	×	20_04_24_01_30_03
		17	Production inhibit time	○	×	00
	Services	DeviceNet Services		Parameter Options		
		05H	Reset	None supported		
		0EH	Get_Attribute_Single	None supported		
		10H	Set_Attribute_Single	None supported		

Object Instance 3	Section	Information		Max. Instance		
		Instance Type	Bit Strobed I/O	1		
		Production Trigger	Cyclic			
		Transport Type	Server			
		Transport Class	2			
	Attributes	ID	Description	Get	Set	Value Limit
		1	State	○	×	
		2	Instance Type	○	×	01H
		3	Transport class trigger	○	×	82H
		4	Produced connenction ID	○	×	
		5	Consumed connection ID	○	×	
		6	Initial comm. Characteristics	○	×	02H
		7	Produced connection size	○	×	0000H
		8	Consumed connection size	○	×	0800H
		9	Expected packed rate	○	○	
		12	Watchdog time-out action	○	×	00
		13	Produced connection path length	○	×	0600
		14	Produced connection path	○	×	20_04_24_01_30_03
		15	Consumed connection path length	○	×	0000
		16	Consumed connection path	○	×	None data
		17	Production inhibit time	○	×	00
	Services	DeviceNet Services		Parameter Options		
		05H	Reset	None supported		
		0EH	Get_Attribute_Single	None supported		
		10H	Set_Attribute_Single	None supported		