

# Drawings

## EJA438E Diaphragm Sealed Pressure Transmitter (Diaphragm seal section, Extended type)



SD 01C31J04-02EN

[Style: S1, S2]

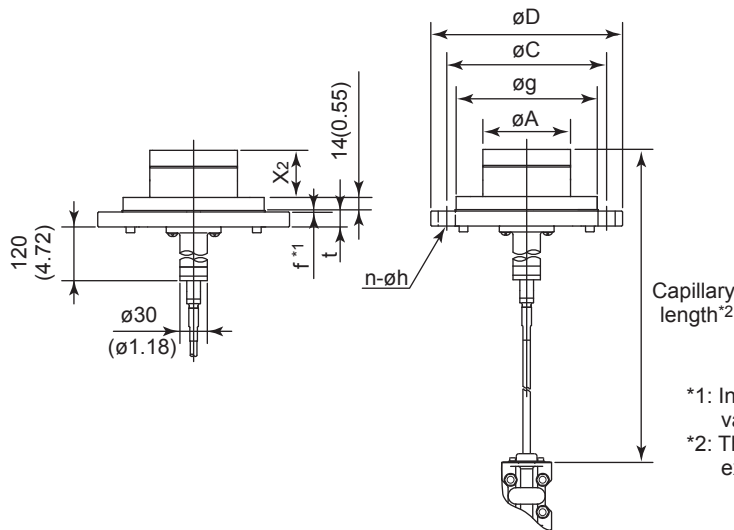

Unit: mm (approx. inch)

\*1: In case where process flange material is JIS S25C, value of f is 0.

\*2: The specified capillary length includes the extension length (X2) and the flange thickness (t).

Process flange size: 4-inch (100mm)

Flange Rating	øD	øC	øg	øA	t	f	Bolt holes	
							No.(n)	Dia.(øh)
JIS 10K	210(8.27)	175(6.89)	155(6.10)	96±0.5(3.78)	18(0.71)	0	8	19(0.75)
JIS 20K	225(8.86)	185(7.28)	155(6.10)	96±0.5(3.78)	24(0.94)	0	8	23(0.91)
JIS 40K	250(9.84)	205(8.07)	155(6.10)	96±0.5(3.78)	36(1.42)	0	8	25(0.98)
ANSI Class 150	228.6(9.00)	190.5(7.50)	155(6.10)	96±0.5(3.78)	23.9(0.94)	1.6(0.06)	8	19.1(0.75)
ANSI Class 300	254(10.00)	200.2(7.88)	155(6.10)	96±0.5(3.78)	31.8(1.25)	1.6(0.06)	8	22.4(0.88)
JPI Class 150	229(9.02)	190.5(7.50)	155(6.10)	96±0.5(3.78)	24(0.94)	1.6(0.06)	8	19(0.75)
JPI Class 300	254(10.00)	200.2(7.88)	155(6.10)	96±0.5(3.78)	32(1.26)	1.6(0.06)	8	22(0.87)
DIN PN 10/16	220(8.66)	180(7.09)	155(6.10)	96±0.5(3.78)	20(0.79)	0	8	18(0.71)
DIN PN 25/40	235(9.25)	190(7.48)	155(6.10)	96±0.5(3.78)	24(0.94)	0	8	22(0.87)

Process flange size: 3-inch (80mm)

Flange Rating	øD	øC	øg	øA	t	f	Bolt holes	
							No.(n)	Dia.(øh)
JIS 10K	185(7.28)	150(5.91)	130(5.12)	71±0.5(2.80)	18(0.71)	0	8	19(0.75)
JIS 20K	200(7.87)	160(6.30)	130(5.12)	71±0.5(2.80)	22(0.87)	0	8	23(0.91)
JIS 40K	210(8.27)	170(6.69)	130(5.12)	71±0.5(2.80)	32(1.26)	0	8	23(0.91)
ANSI Class 150	190.5(7.50)	152.4(6.00)	130(5.12)	71±0.5(2.80)	23.9(0.94)	1.6(0.06)	4	19.1(0.75)
ANSI Class 300	209.6(8.25)	168.1(6.62)	130(5.12)	71±0.5(2.80)	28.5(1.12)	1.6(0.06)	8	22.4(0.88)
JPI Class 150	190(7.48)	152.4(6.00)	130(5.12)	71±0.5(2.80)	24(0.94)	1.6(0.06)	4	19(0.75)
JPI Class 300	210(8.27)	168.1(6.62)	130(5.12)	71±0.5(2.80)	28.5(1.12)	1.6(0.06)	8	22(0.87)
DIN PN 10/16	200(7.87)	160(6.30)	130(5.12)	71±0.5(2.80)	20(0.79)	0	8	18(0.71)
DIN PN 25/40	200(7.87)	160(6.30)	130(5.12)	71±0.5(2.80)	24(0.94)	0	8	18(0.71)

### • Extension length (X2)

Extension code	X2
1	50(1.97)
3	100(3.94)
5	150(5.91)