



FLOWSIC100 Flare-XT

POWERFUL. RELIABLE. RUGGED

Gas flow measuring instruments

SICK
Sensor Intelligence.



FLOWSIC100 Flare-XT: Powerful. Reliable. Rugged.

Increasing competition in the process industry means that operations and service work have to be optimized continuously. When it comes to flare gas measurement, the new FLOWSIC100 Flare-XT make saving costs so easy. State-of-the-art ultrasonic measuring technology provides maximum performance and robustness. As a result, the sensor continuously calculates accurate values even under extremely unstable conditions. An addition to this: Thanks to i-diagnostics™, the system monitors itself and informs the user in realtime when maintenance is due, thereby making fix service intervals a thing of the past. We think that's intelligent.

FLARE GAS MEASUREMENT REDEFINED: FLAWSIC100 Flare-XT

Dealing with difficult flare gas conditions the requirements for measuring technology pose a challenge in the oil and gas and the chemical and petrochemical industry:

- Gas velocities of 0 to 394 ft/s
- Rapid changes in the gas velocity
- Rapidly changing gas mixtures natural gas, hydrogen, carbon dioxide, etc.

Ultrasonic flow meters continue to set the standard in Flow Measurement when it comes to dynamic range and accuracy. With FLAWSIC100 Flare-XT, SICK has developed a new generation of ultrasonic measuring devices that work completely reliably and accurately even under extreme conditions, are installed in next to no time and constantly monitor themselves thanks to the self-diagnostics function i-diagnostics™.

FLAWSIC100 Flare-XT at a glance:

- Measurement availability even at high gas velocities and with changing gas mixtures
- Proprietary measurement range extension for high flow velocities thanks to ASC-technology (active sound correlation)
- Intuitive FLOWgate™ operating software
- i-diagnostics™ for self-monitoring, easy testing and preventive maintenance of the complete system
- Retrofit solution for existing measurement systems



Flare gas measurement on offshore platforms...



...and in plants in the chemical and petrochemical industry

In use all over the world. Based on the application experience of a global fleet of thousands of FLAWSIC100 Flare installations, the reinvented FLAWSIC100 Flare-XT is applicable in flare gas measurements worldwide. The requirements of various directives and standards are observed.

(ISO 17089-2, EPA 40 CFR part 98, 30 CFR Part 250, 40 CFR Part 60 Subpart Ja, MACT RSR 63.670, API 14.10 etc.)

Explosion protection requirements: ATEX, CSA and IECEx. INMETRO certification and TR ZU certification to follow.



THE RIGHT SOLUTION FOR EVERY CHALLENGE

FLOWSIC100 Flare-XT is available in three different versions. Whether the application's complex gas compositions or specific installation conditions pose a challenge, reliable gas flow measurement is ensured at all times.

FLOWSIC100 Flare-XT is available as a 1- or 2-path measurement system. The 2-path version achieves high measurement accuracies even under difficult flow conditions. Cross-duct installation and single nozzle probe systems are available in either path configuration. The probe and 90° installation version is suitable for compact, one-sided fitting, which minimizes

the installation work required. A device retraction mechanism also allows sensors to be replaced simply and quickly during plant operation.

The Interface Unit processes incoming signals and calculates parameters, such as molecular weight, mass flow and gas volume, as well as standardized reference values. Via an infrared interface, the system can be operated intuitively from a laptop or tablet thanks to the FLOWgate™ software. Integrated Ethernet and RS-485 interfaces allow the device status to be monitored remotely.

	F1F-S	F1F-H	F1F-P
			
Type	Cross-duct measurement		Probe
Number of possible measuring paths	1-path / 2-path		
Pipe size 1-path	4" - 20"	22" - 72"	12" - 72"
Pipe size 2-path	12" - 20"		18" - 72"
Equipment Protection Level	Intrinsic safety	Flameproof	Intrinsic safety
Speciality	Suitable for low-temperature applications	-	Suitable for low-temperature applications
	Powerful, hermetically sealed titanium sensors		
	-	For complex gas compositions and challenging application conditions	Single side installation, only one side access required. Only single weld-on nozzle.

The FLOWSIC100 Flare-XT measurement solution is available as Flare Instrument which is installed by welding the nozzles to the existing pipeline. Alternatively a Flare Meter solution with integrated spool piece offers easy installation without welding and the possibility to have a dry or flow calibration to obtain a higher measurement accuracy.

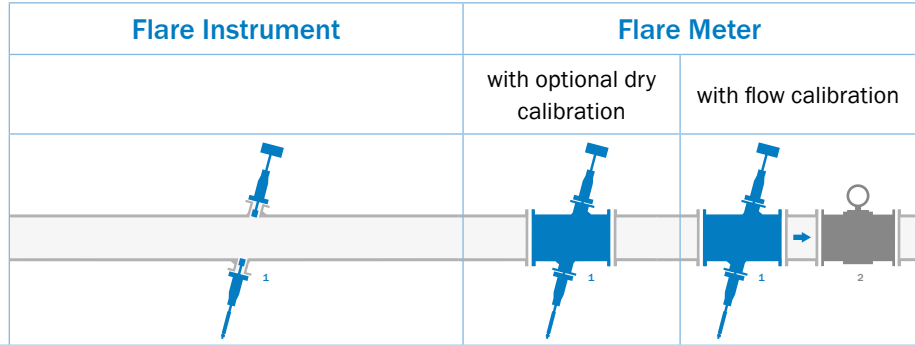

¹Blue parts: SICK Scope of delivery

²Gray parts: Reference Meter

		Flare Instrument		Flare Meter	
				with optional dry calibration	with flow calibration
Customer Application Framework		<ul style="list-style-type: none"> Tapped pipe or unspecified spool piece geometry Unknown or known application conditions 		<ul style="list-style-type: none"> Flanged spool piece by SICK Known application conditions 	
Advantages		<ul style="list-style-type: none"> Easy retrofit of existing pipelines 		<ul style="list-style-type: none"> Easy installation without welding 	
Standard delivery scope		<ul style="list-style-type: none"> Sensors + Interface Unit Product and material certification 		<ul style="list-style-type: none"> Flare meter fully assembled Product and material certification Performance capability evaluation 	
Optional delivery scope		<ul style="list-style-type: none"> Performance capability evaluation Customized documentation Customer service training i-diagnostics™ 		<ul style="list-style-type: none"> Customized documentation Customer service training i-diagnostics™ 	
Applicable Installation equipment	Weld-on nozzles	x		-	-
	Nozzle installation tool	x		-	-
	Ball valves	x		x	x
	Weather and sun protection	optional		optional	optional

FIT FOR THE SYSTEM ENVIRONMENTS OF TODAY AND TOMORROW

The powerful Interface Unit can be easily connected to a wide variety of systems and networks thanks to its numerous interfaces. Key parameters and measured value data such as volume flow, mass flow or molecular weight are reliably

processed, evaluated and stored. In this respect, the internal memory makes it possible to permanently archive the data in a secure and structured manner.

- Easy access via the infrared interface
- IP66
- Extensive memory for data archiving over several years
- Modular I/O concept: Ethernet TCP/IP, Foundation Fieldbus, HART®, Modbus®



SAVE COSTS WITH THE RIGHT ARCHITECTURE: Thanks to rugged, digital communication, the Interface Unit can be installed up to 3280 ft away from the measurement point. There is therefore no longer any need for a local, flameproof and potentially expensive control unit.

LEADING ULTRASONIC TECHNOLOGY, WITHSTANDS EVERY SITUATION

SICK-quality sensor technology

Thanks to advanced signal processing, the hermetically sealed high-performance ultrasonic sensor allows a very high resolution of the signals and measures reliably and accurately even at very low gas velocities close to zero.

FLOWSIC100 Flare-XT is also capable of performing measurements even under extreme conditions, with varying gas compositions and at high flow velocities. Developed specially for use at very high gas flows, measurement is also continuously available in the event of extreme background noise, gas turbulence and emergency shutdown.

Precise measurement even at very low gas velocities close to zero

Hermetically sealed ultrasonic sensors made of titanium

Above-average availability and resistance even under extreme measurement conditions

Patented, flow-optimized sensor design



Patented ASC-technology

Ensuring measurement availability even at the highest gas velocities is one of the most important characteristics of a flare measurement system. Thanks to its innovative ASC-technology (active sound correlation technology), FLOW SIC100 Flare-XT is

now extending previous maximum flow range by up to 30%. ASC correlates the gas velocity with application-specific noise generated at high flow conditions. The patented ASC-technology thus allows an even better coverage of possible flare gas events.

Flow Measurement with Ultrasonic transit time difference measurement			Flow Measurement with ASC-technology
Thanks to high-resolution sensors, the state-of-the-art electronics precisely detects even very small transit time differences.	The ultrasonic sensors made of titanium are long-term stable and allow safe and reliable operation.	The innovative, flow optimized sensor contour allows optimal measurement results even at very high gas velocities.	If the signal is blown away due to extreme gas velocity, the patented ASC-technology algorithm ensures uninterrupted measurement.

Commissioning, parameterization and monitoring – easier than ever before with FLOWgate™

The intuitive software FLOWgate™ makes measurement, diagnostic and device data easier to handle, thereby permitting quick and uncomplicated system analysis. By means of graphically prepared data and trend analyses, measurement

processes can be easily traced, status changes can be identified early on and reports can be compiled. Various solution assistants also provide support when it comes to installation, monitoring and servicing.

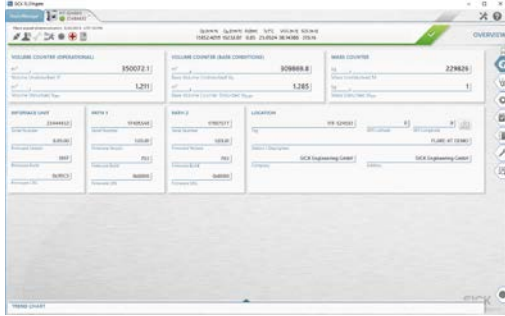

All relevant measured values are displayed on the overview page



Clear display of measured values and diagnostic data

From time-based to condition-based maintenance thanks to i-diagnostics™



Predictive maintenance: flexible service intervals

The system permanently monitors parameters such as the “automatic gain control” or the “signal-to-noise ratio”. Based on existing data and the development of measured values, i-diagnostics™ provides reliable predictions and maintenance recommendations. System-critical operating conditions are thus avoided – and unplanned downtimes are prevented.



One-click verification report: instant device verification

On request, the system checks itself and logs its current status. Users thus have the uncomplicated option of creating verification documents to prove that all emission requirements have been met.



Automated self-diagnostics

i-diagnostics™ links software and firmware intelligently: The self-monitoring system provides valuable data on the device status and shows all changes. Application errors are immediately detected and documented – there is no need for lengthy troubleshooting.

Retrofit solution for flare gas measuring devices

With the revamping solutions from SICK, converting an ultrasonic measurement for flare gas becomes child's play. You keep your nozzles, your shut-off valves, your p/T transmitters and even your cabling: Retrofitting your flare gas system with modern flare gas measurement technology from SICK has never been easier. Since you can continue to use the existing nozzles and shut-off valves, no hot tapping or pressure reduction on the flare gas line is required. Both cross-duct and single-sided installations with measurement angles of 45°, 60°, 75° and 90° are easily exchangeable.



Retrofit solutions for existing measurement systems

FLARE GAS MEASUREMENT REDEFINED: FLOWSIC100 Flare-XT

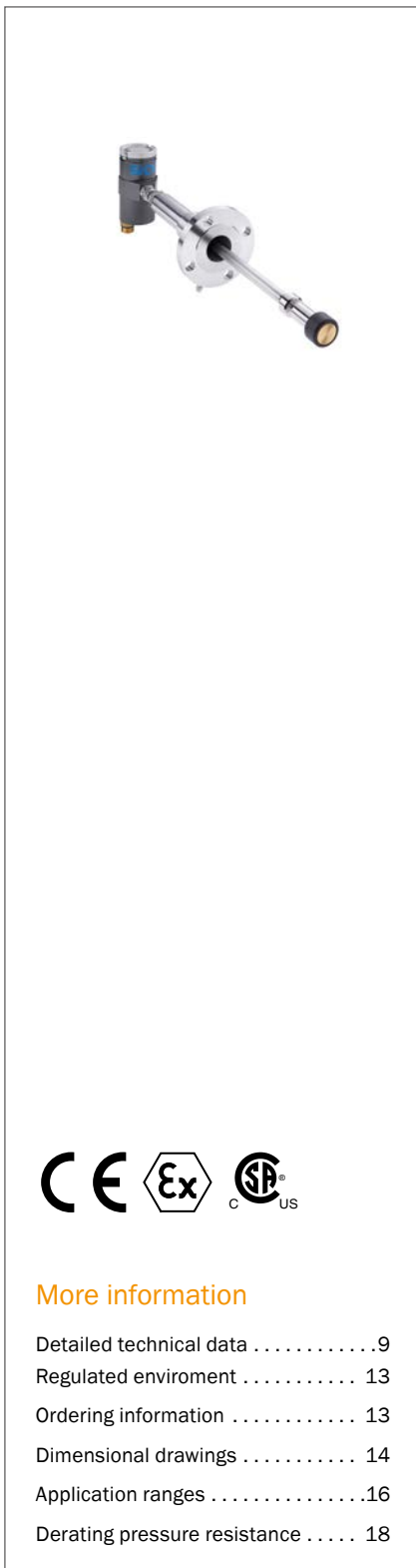

More information

Detailed technical data9
 Regulated environment 13
 Ordering information 13
 Dimensional drawings 14
 Application ranges16
 Derating pressure resistance 18

Product description

The gas flow measuring instrument FLOWsIC100 Flare-XT features a unique flow-optimized sensor design, which allows reliable measurements at high gas velocities and changing gas compositions. The rugged design and patented ASC-technology ensure improved measurement availability even under the most adverse conditions.

FLOWsIC100 Flare-XT meets several applicable standards and is suitable for use in new and existing plants. Measurement and diagnostic data are easily visualized by the FLOWgate™ software. Thanks to the intelligent diagnostic function i-diagnostics™ the system checks itself and reports independently if maintenance is required.

At a glance

- Measurement availability under all operating conditions, at high gas velocities and with changing gas compositions
- Intuitive FLOWgate™ operating software
- i-diagnostics™ for self monitoring, easy verification and condition-based maintenance of the system
- Retrofit solutions for existing measurement systems

Your benefit

- Several standards and guidelines for flare gas measurement are observed
- Maximum plant availability
- Ultrasonic sensors, Interface Unit, Spool Piece from a single source as well as globally available services
- Compatible with current and future communication architectures
- Independent maintenance through verification on demand and support by SICK when required
- Easy replacement of existing measurement systems, with suitable retrofit or upgrade solutions available

Fields of application

- Flare gas measurement for the production and processing of natural gas and associated petroleum gases (APG) in oil production
- Flare gas measurement in chemical and petrochemical plants as well as refineries
- Measurement of LNG boil-off gas down to -320°F
- Plants onshore and offshore
- Flare gas containing H₂S, CO₂ and H₂

→ www.sick.com/FLOWsIC100_Flare-XT

For more information, simply visit the above link to obtain direct access to technical data, CAD design models, operating instructions, software, application examples, and much more.



Detailed technical data

The exact device specifications and performance data of the product may deviate from the information provided here, and depend on the application in which the product is being used and the relevant customer specifications. Please contact your local SICK representative to inquire about the FLOWSIC100 Flare-XT performance for your application.

System FLOWSIC100 Flare-XT

Measured values	Mass flow rate, volumetric flow s. c. (standard condition), volumetric flow a. c. (actual condition), molecular weight, gas volume and mass, gas velocity, gas temperature, sound velocity
Number of measuring paths	Single path, Dual path
Nominal pipe size	4 " ... 72 " 12 " ... 72 " Other nominal sizes on request
1-path measurement 2-path measurement	
Measurement principle	Ultrasonic transit time difference measurement, ASC-technology (active sound correlation)
Measuring medium	Typical flare gas
Measuring ranges ¹	0.1 ft/s ... 394 ft/s
Measuring span ¹	Up to 4000:1
Repeatability	(acc to ISO 5725-1; JCGM 200:2012): < 0.5 % of the measured value in the range ≥ 3.3 ft/s
Resolution	(acc. to JCGM 200:2012): + 0.003 ft/s
Uncertainty of measurement ¹⁻³	
Volumetric flow a. c.	1 % ... 5 % Related to the measured value with ultrasonic technology (in the range ≥ 1 ft/s to measuring range end value)
Mass flow rate	0.5 % ... 1.5 % with Spool Piece and flow calibration Related to the measured value with ultrasonic technology (in the range ≥ 3.3 ft/s to calibration range end value) ⁴ 2 % ... 5.5 % Related to the measured value with ultrasonic technology (in the range ≥ 1 ft/s to measuring range end value) 1.5 % ... 2 % with Spool Piece and flow calibration Related to the measured value with ultrasonic technology (in the range ≥ 3.3 ft/s to calibration range end value) ⁴
Uncertainty of measurement ASC-technology ^{1,2,5}	
Volumetric flow a. c.	1 % ... 8 %
Ambient humidity	≤ 95 % Relative humidity
Conformities	ATEX: 2014/34/EU EMC: 2014/30/EU RoHS: 2011/65/EU PED: 2014/68/EU
Electrical safety	IEC 61010-1
Footnote	¹ Depending on the application conditions such as gas composition, process temperature, type of device, pipe diameter, etc. For mass flow additionally selection and parameterization of the conversion algorithm as well as uncertainty of the pressure and temperature sensors. To be evaluated by SICK. ² With fully developed turbulent flow profile. Typically 20D straight upstream and 5D straight downstream piping is required. ³ Below a specific threshold Reynolds number, only run time effects and uncertainties of geometry, excluding contributions from the flow profile are considered. ⁴ Depending on the capabilities of the selected flow lab. ⁵ Additional uncertainty. In the range 100 % ... 130 % of the last gas velocity measurable with ultrasonic transit time difference measurement.

General technical information for ultrasonic sensors

Ambient temperature	
Sensors, ignition group IIC T4	-40 °F ... +158 °F
Sensors, ignition group IIC T4	-58 °F ... +158 °F (Optional)
Sensors, ignition group IIC T6	-40 °F ... +131 °F
Sensors, ignition group IIC T6	-58 °F ... +131 °F (Optional)
Storage temperature	-40 °F ... +158 °F -58 °F ... +158 °F (Optional)
Enclosure rating	IP66 / IP67
Dimensions (W x H x D)	For details see dimensional drawings

F1F-S

Operating pressure ¹	
CL150 device flange	290 psi(g)
PN25 device flange (optional)	290 psi(g)
CL300 device flange (optional)	290 psi(g)
	¹ Temperature dependent. For details, see section Application ranges.
Ex-approvals	
IECEX	Ex db [ia Ga] IIA T4 Ga/Gb Ex db [ia Ga] IIB T4 Ga/Gb Ex db [ia Ga] IIC T6 Ga/Gb Ex ia IIC T6 Ga
ATEX	II 1/2G Ex db [ia Ga] IIA T4 Ga/Gb II 1/2G Ex db [ia Ga] IIB T4 Ga/Gb II 1/2G Ex db [ia Ga] IIC T6 Ga/Gb II 1G Ex ia IIC T6 Ga
NEC/CEC (US/CA)	Class I, Division 1, Group D, T4; Class I, Zone 1, Ex/AEx d[ia] IIA, T4; Class I, Division 2, Group D, T4; Class I, Zone 2, Ex/AEx nA[ia] IIA, T4 Class I, Division 1, Groups C and D, T4; Class I, Zone 1, Ex/AEx d[ia] IIB, T4; Class I, Division 2, Groups C and D, T4; Class I, Zone 2, Ex/AEx nA[ia] IIB, T4 Class I, Division 1, Groups B, C and D, T4; Class I, Zone 1, Ex/AEx d[ia] IIB + H2, T4; Class I, Division 2, Groups A, B, C and D, T4; Class I, Zone 2, Ex/AEx nA[ia] IIC, T4
Gas temperature	-320 °F ... +536 °F
Weight	≤ 26 lbs (pair of ultrasonic sensors)

F1F-H

Operating pressure ¹		
CL150 device flange		ATEX/IECEX: 290 psi(g) CSA: 232 psi(g)
PN25 device flange (optional)		ATEX/IECEX: 290 psi(g) CSA: 232 psi(g)
CL300 device flange (optional)		ATEX/IECEX: 290 psi(g) CSA: 232 psi(g)
		¹ Temperature dependent. For details, see section Application ranges.
Ex-approvals		
	IECEX	Ex db IIC T6 Gb
	ATEX	II 2G Ex db IIC T6 Gb
	NEC/CEC (US/CA)	Class I, Division 1, Groups B, C and D, T4; Class I, Zone 1, Ex/AEx d IIB + H2, T4; Class I, Division 2, Groups A, B, C and D, T4; Class I, Zone 2, Ex/AEx nA IIC, T4
Gas temperature		-94 °F ... +536 °F
Weight		≤ 31 lbs (pair of ultrasonic sensors)

F1F-P

Operating pressure ¹		
CL150 device flange		ATEX/IECEX: 290 psi(g) CSA: 232 psi(g)
PN25 device flange (optional)		ATEX/IECEX: 290 psi(g) CSA: 232 psi(g)
CL300 device flange (optional)		ATEX/IECEX: 290 psi(g) CSA: 232 psi(g)
		¹ Temperature dependent. For details, see section Application ranges.
Ex-approvals		
	IECEX	Ex db [ia Ga] IIA T4 Ga/Gb Ex db [ia Ga] IIB T4 Ga/Gb Ex db [ia Ga] IIC T6 Ga/Gb
	ATEX	II 1/2G Ex db [ia Ga] IIA T4 Ga/Gb II 1/2G Ex db [ia Ga] IIB T4 Ga/Gb II 1/2G Ex db [ia Ga] IIC T6 Ga/Gb
	NEC/CEC (US/CA)	Class I, Division 1, Group D, T4; Class I, Zone 1, Ex/AEx d[ia] IIA, T4; Class I, Division 2, Group D, T4; Class I, Zone 2, Ex/AEx nA[ia] IIA, T4 Class I, Division 1, Groups C and D, T4; Class I, Zone 1, Ex/AEx d[ia] IIB, T4; Class I, Division 2, Groups C and D, T4; Class I, Zone 2, Ex/AEx nA[ia] IIB, T4 Class I, Division 1, Groups B, C and D, T4; Class I, Zone 1, Ex/AEx d[ia] IIB + H2, T4; Class I, Division 2, Groups A, B, C and D, T4; Class I, Zone 2, Ex/AEx nA[ia] IIC, T4
Gas temperature		-320 °F ... +536 °F
Weight		≤ 22 lbs (pair of ultrasonic sensors)

Interface Unit

Description	Unit for controlling the ultrasonic sensors and processing, evaluation and storage of measured value data																
Ambient temperature	-40 °F ... +140 °F -40 °F ... +149 °F (optional (limited I/O))																
Storage temperature	-40 °F ... +158 °F																
Ambient pressure	80 kPa ... 110 kPa (11.6 psi ... 15.9 psi)																
Ambient humidity	≤ 95 % Relative humidity																
Ex-approvals	<table border="0"> <tr> <td style="padding-right: 20px;">IECEX (Zone 1)</td> <td>Ex db eb ia IIC T4 Gb Ex db ia IIC T4 Gb</td> </tr> <tr> <td style="padding-right: 20px;">ATEX (Zone 1)</td> <td>II 2G Ex db eb ia IIC T4 Gb II 2G Ex db ia IIC T4 Gb</td> </tr> <tr> <td style="padding-right: 20px;">NEC/CEC (US/CA) (Zone 1)</td> <td>Ex d ia IIC T4 Gb Class I, Zone 1, AEx d ia IIC T4 Gb Class I, Division 1, Groups B, C, D, T4</td> </tr> <tr> <td style="padding-right: 20px;">IECEX (Zone 2)</td> <td>EX ec ia IIC T4 Gc</td> </tr> <tr> <td style="padding-right: 20px;">ATEX (Zone 2)</td> <td>II 3G Ex ec ia IIC T4 Gc</td> </tr> <tr> <td style="padding-right: 20px;">NEC/CEC (US/CA) (Zone 2)</td> <td>Ex ec ia IIC T4 Gc Class I Zone 2, AEx ec ia IIC T4 Gc Class I Division 2, Group A, B, C and D, T4</td> </tr> </table>	IECEX (Zone 1)	Ex db eb ia IIC T4 Gb Ex db ia IIC T4 Gb	ATEX (Zone 1)	II 2G Ex db eb ia IIC T4 Gb II 2G Ex db ia IIC T4 Gb	NEC/CEC (US/CA) (Zone 1)	Ex d ia IIC T4 Gb Class I, Zone 1, AEx d ia IIC T4 Gb Class I, Division 1, Groups B, C, D, T4	IECEX (Zone 2)	EX ec ia IIC T4 Gc	ATEX (Zone 2)	II 3G Ex ec ia IIC T4 Gc	NEC/CEC (US/CA) (Zone 2)	Ex ec ia IIC T4 Gc Class I Zone 2, AEx ec ia IIC T4 Gc Class I Division 2, Group A, B, C and D, T4				
IECEX (Zone 1)	Ex db eb ia IIC T4 Gb Ex db ia IIC T4 Gb																
ATEX (Zone 1)	II 2G Ex db eb ia IIC T4 Gb II 2G Ex db ia IIC T4 Gb																
NEC/CEC (US/CA) (Zone 1)	Ex d ia IIC T4 Gb Class I, Zone 1, AEx d ia IIC T4 Gb Class I, Division 1, Groups B, C, D, T4																
IECEX (Zone 2)	EX ec ia IIC T4 Gc																
ATEX (Zone 2)	II 3G Ex ec ia IIC T4 Gc																
NEC/CEC (US/CA) (Zone 2)	Ex ec ia IIC T4 Gc Class I Zone 2, AEx ec ia IIC T4 Gc Class I Division 2, Group A, B, C and D, T4																
Enclosure rating	IP66 acc. IEC 60529, Type 4X acc. UL50E																
Analog outputs	Up to 6 outputs when using I/O modules (Option) 16 bit: 4 mA ... 20 mA 7 V DC ... 30 V DC In accordance with NAMUR NE43 Passive, electrically insulated Reverse polarity protection																
Analog inputs	Up to 6 outputs when using I/O modules (Option) 24 bit: 4 mA ... 20 mA 0 V ... 5 V DC In accordance with NAMUR NE43 Passive, electrically insulated Reverse polarity protection																
Digital outputs	<p>Switching output: Up to 6 outputs when using I/O modules (Option) Electrically isolated</p> <table border="0"> <tr> <td style="padding-right: 20px;">Max. Current</td> <td>70 mA</td> </tr> <tr> <td style="padding-right: 20px;">Max. Switching frequency</td> <td>50 Hz</td> </tr> <tr> <td style="padding-right: 20px;">Max. Input voltage</td> <td>30 V DC</td> </tr> <tr> <td style="padding-right: 20px;">Max. Saturation voltage at output</td> <td>0.5 V DC</td> </tr> </table> <p>Switchable Namur/open collector Reverse polarity protection</p> <p>Digital output/frequency output: Up to 12 digital outputs when using I/O modules (option) Electrically isolated</p> <table border="0"> <tr> <td style="padding-right: 20px;">Max. Current</td> <td>50 mA</td> </tr> <tr> <td style="padding-right: 20px;">Max. Switching frequency</td> <td>10 kHz</td> </tr> <tr> <td style="padding-right: 20px;">Max. Input voltage</td> <td>30 V DC</td> </tr> <tr> <td style="padding-right: 20px;">Max. Saturation voltage at output</td> <td>1.8 V DC</td> </tr> </table> <p>Switchable Namur/open collector Reverse polarity protection</p>	Max. Current	70 mA	Max. Switching frequency	50 Hz	Max. Input voltage	30 V DC	Max. Saturation voltage at output	0.5 V DC	Max. Current	50 mA	Max. Switching frequency	10 kHz	Max. Input voltage	30 V DC	Max. Saturation voltage at output	1.8 V DC
Max. Current	70 mA																
Max. Switching frequency	50 Hz																
Max. Input voltage	30 V DC																
Max. Saturation voltage at output	0.5 V DC																
Max. Current	50 mA																
Max. Switching frequency	10 kHz																
Max. Input voltage	30 V DC																
Max. Saturation voltage at output	1.8 V DC																

Digital inputs	Up to 6 with use of I/O modules (Option) Electrically isolated For connecting volt-free contacts or active switching outputs
Min. input on voltage	2 V DC
Max. input off voltage	2.85 V DC
Max. clamping voltage	Max. clamping voltage 30 V DC Reverse voltage protection
Serial	✓ (3)
Type of fieldbus integration	RS-485 Electrically isolated
Ethernet	✓
Data transmission rate	10 Mbit/s ... 100 Mbit/s
Modbus	✓
Type of fieldbus integration	TCP RTU RS-485 ASCII RS-485
HART®	✓
Type of fieldbus integration	HART® master for connecting external pressure and temperature transmitter HART® slave (for communication with control system)
Foundation Fieldbus	✓
Comment	(Option)
Data transmission rate	Clamping voltage: DC 9 V DC ... 32 V DC Current consumption: 18 mA FOUNDATION fieldbus™ H1, IEC 61158-2 with 31.25 kBit/s ITK 6.3 3 transducer blocks for process measurement variables, counter readings and diagnostic variables 8 AI blocks 1 PID block
Optical interface	✓
Type of fieldbus integration	Service interface (IR, according to IEC 62056-21)
Indication	LCD: Measurands, system information, maintenance, need for maintenance, alarm
Operation	Software FLOWgate™ or operating panel on the LCD
Dimensions (W x H x D)	For details see dimensional drawings
Weight	
Zone 1/Div 1 Ex db Ausführung	17,5 kg
Zone 1 Ex db eb Ausführung	23 kg
Non-Ex/Zone 2	8 kg
Electrical connection	
Voltage	115 V AC ... 230 V AC ±10% / 15 V DC ... 28 V DC
Frequency	AC variant: 50 Hz ... 60 Hz
Power consumption	≤ 18 W (AC variant) / ≤ 12 W (DC variant)
Options	Offshore-version, sun and weather protection, tag plate, mounting set 2-inch-pipe installation, infrared-USB adapter, cable glands

Applications of FLOWSIC100 Flare-XT in regulated environment

The gas flow measuring instrument can be applied in emission measurements which may be subject to one or more regulations in some jurisdictions. Compliance to all emissions regulations applicable at the installation site remains owner / operator responsibility. If designed and applied correctly SICK's ultrasonic flow technology will meet or exceed most performance requirements set forth by any regulatory authority. Please contact your SICK representative to inquire about the correct flare measurement solution which will meet the currently applicable requirements set forth by the authorities.

Ordering information

Our regional sales organization will be glad to advise you on which device configuration is best for you.

Dimensional drawings (dimensions in inch)

Interface Unit Cl. 1 Div. 2

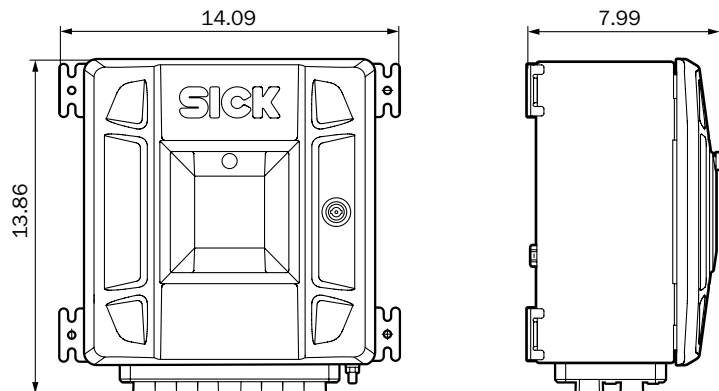

Interface Unit Zone 2

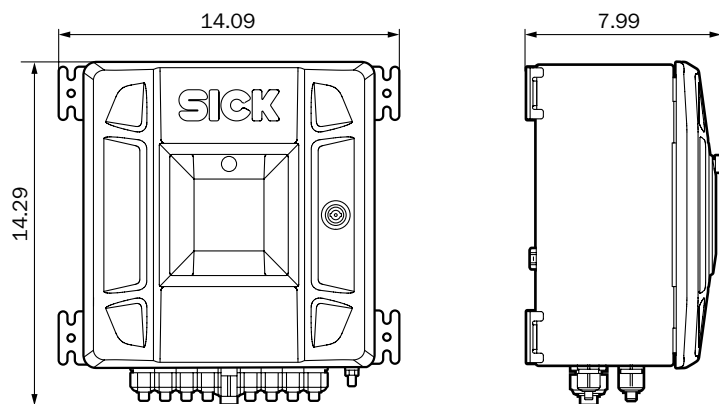

Interface Unit Zone 1 EXDE

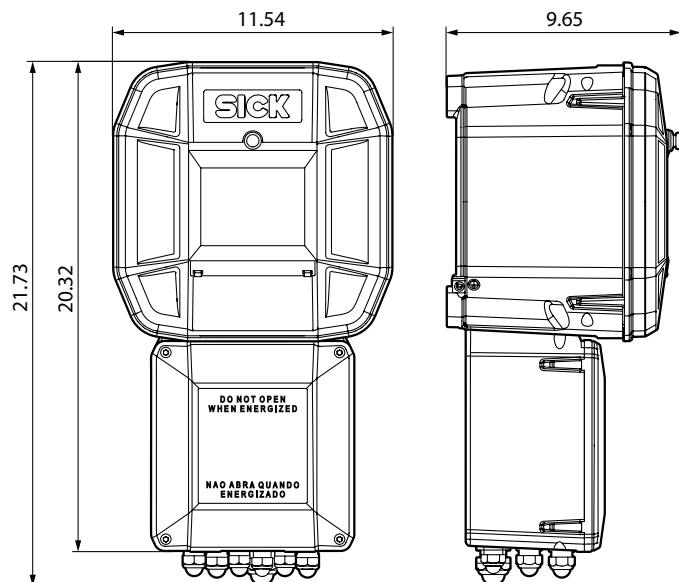

Interface Unit CI.1 Div. 1 and Zone 1 EXD

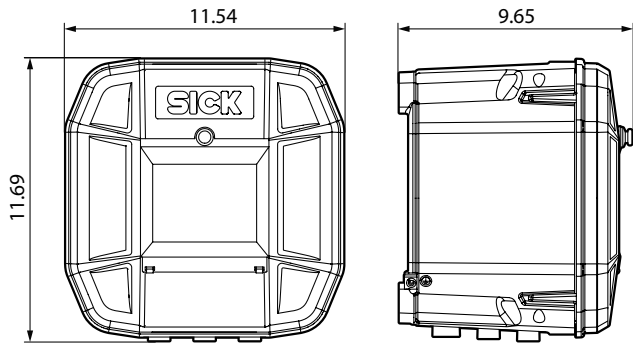

F1F-S/H

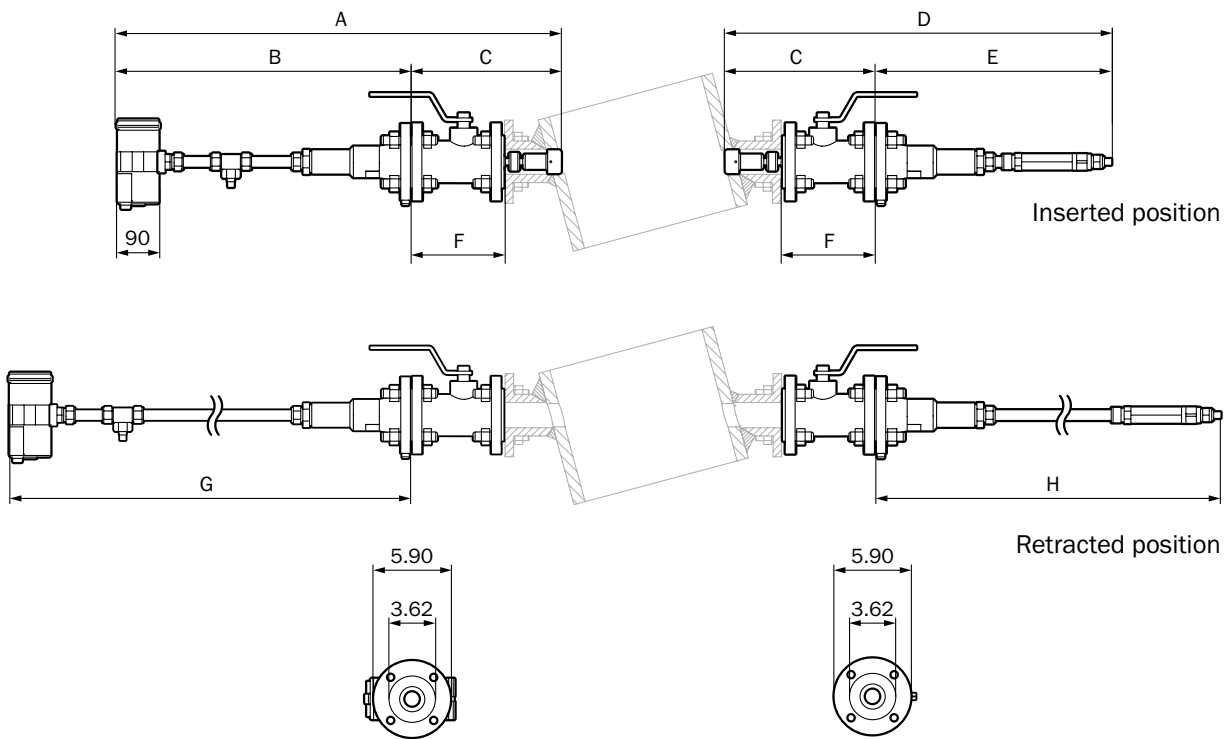

Flare-XT Extended version	Dimensions							
	A	B	C	D	E	F	G	H
F1F-S	38.70	22.95	15.75	34.29	18.54	7.00	41.55	37.16
F1F-H	33.31	17.64	15.67	36.18	20.39	7.00	33.50	36.10

Flare-XT Compact version	Dimensions							
	A	B	C	D	E	F	G	H
F1F-S	34.76	22.95	11.81	30.35	18.54	7.00	37.62	33.23
F1F-H	29.37	17.64	11.73	32.13	20.39	7.00	29.57	32.17

F1F-P

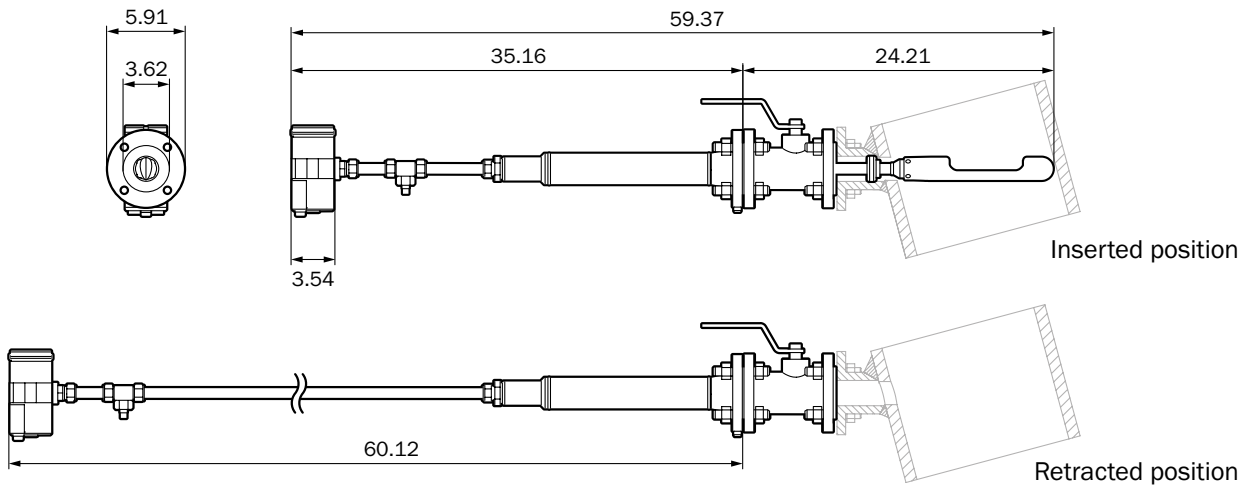

Application ranges

The exemplary application ranges assume a gas temperature of 68 °F at ambient pressure.

V_{max} of 1-path and 2-path solutions dependent on speed of sound (SOS)

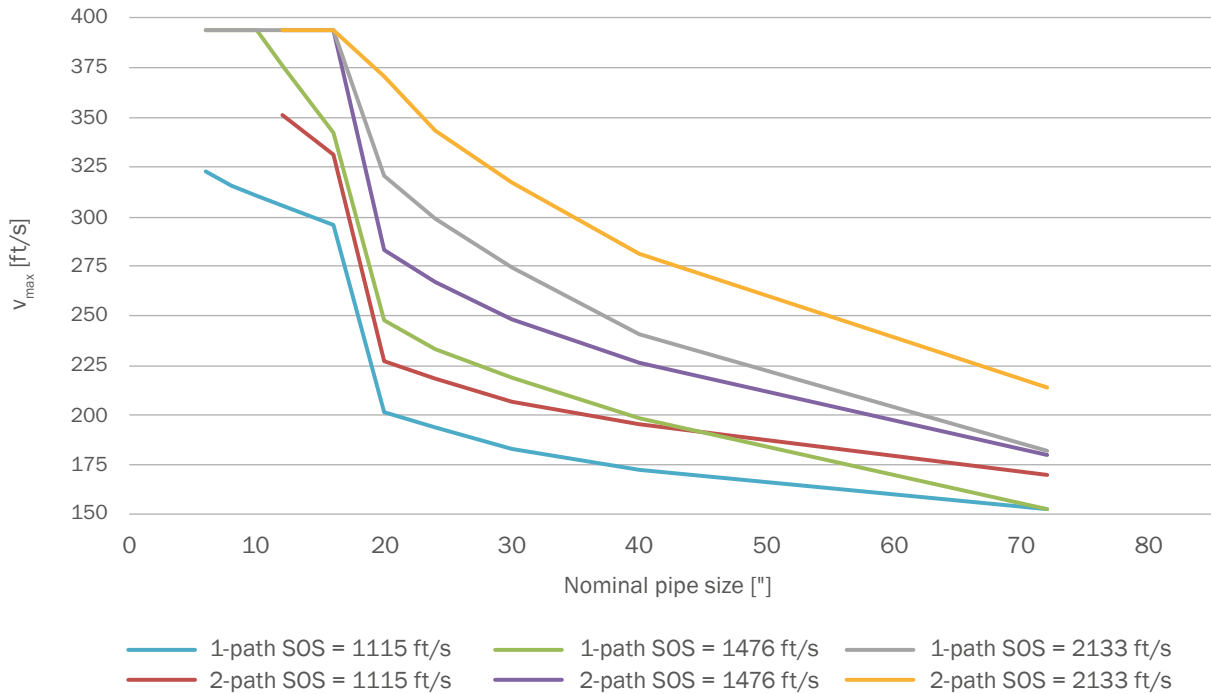

V_{min} at 20% uncertainty of 1-path and 2-path solutions dependent on speed of sound

Hot Tapped / Dry Calibrated / Flow Calibrated

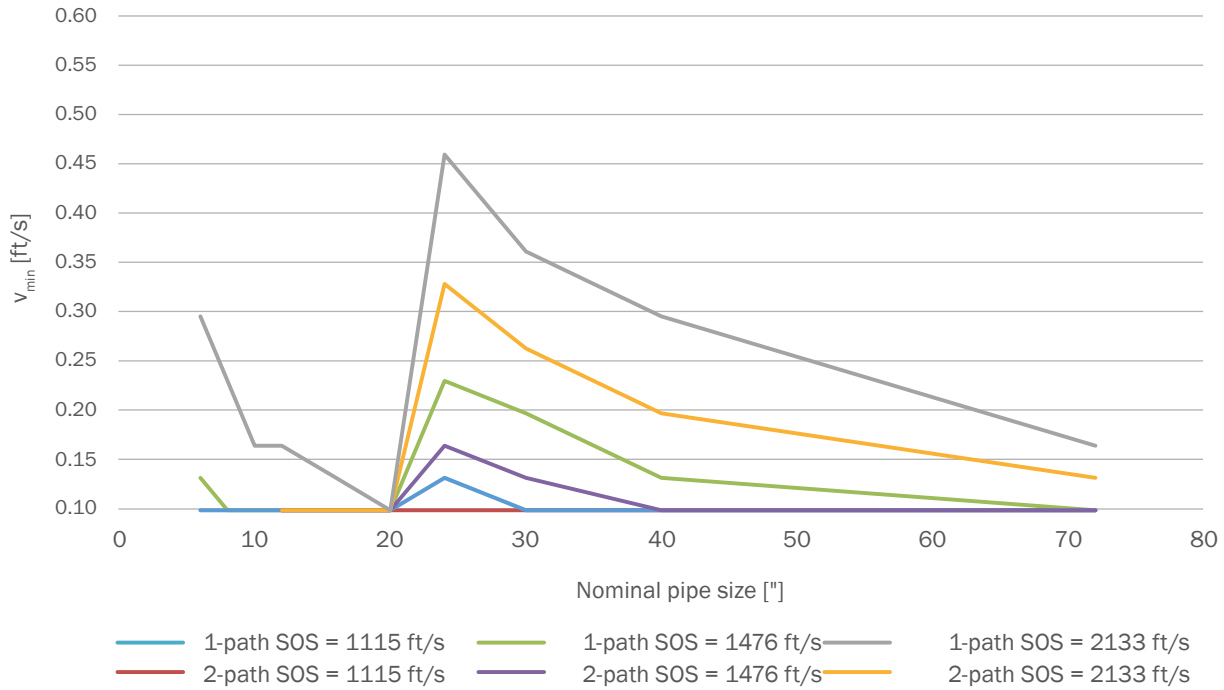

Uncertainty of volume flow as a function of velocity of gas (VOG)

Ultrasonic measurement

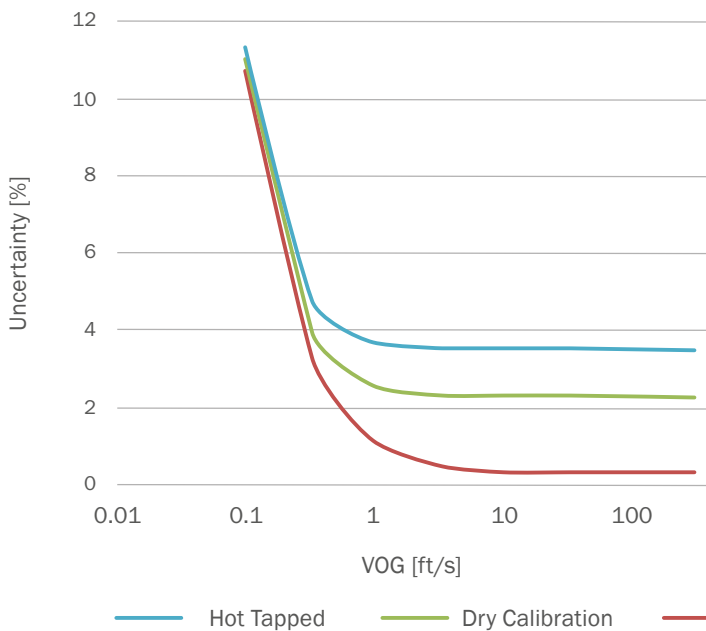

ASC-technology

(Additional uncertainty onto ultrasonic measurement.)

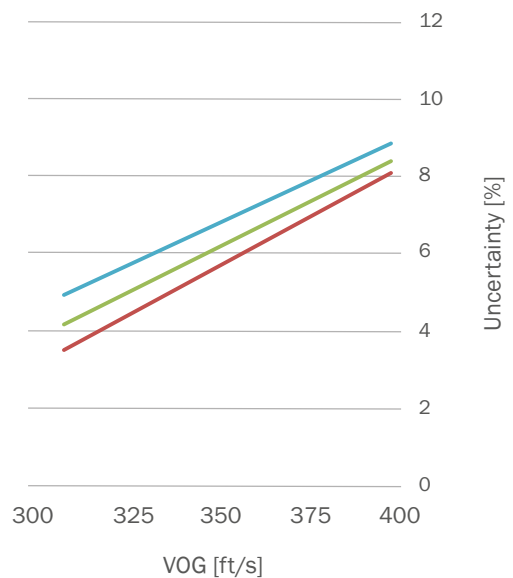

Hot Tapped Dry Calibration Flow Calibration

This exemplary uncertainty statement according to GUM (Guide to the Expression of Uncertainty in Measurement): ISO/IEC Guide 98-3:2008-09 shows a F1F-S in 1-path, 16" nominal pipe size configuration and assumes a gas temperature of 68 °F, ambient pressure, a typical molecular weight of greater than 27 g/mol.

Derating pressure resistance

F1F-S

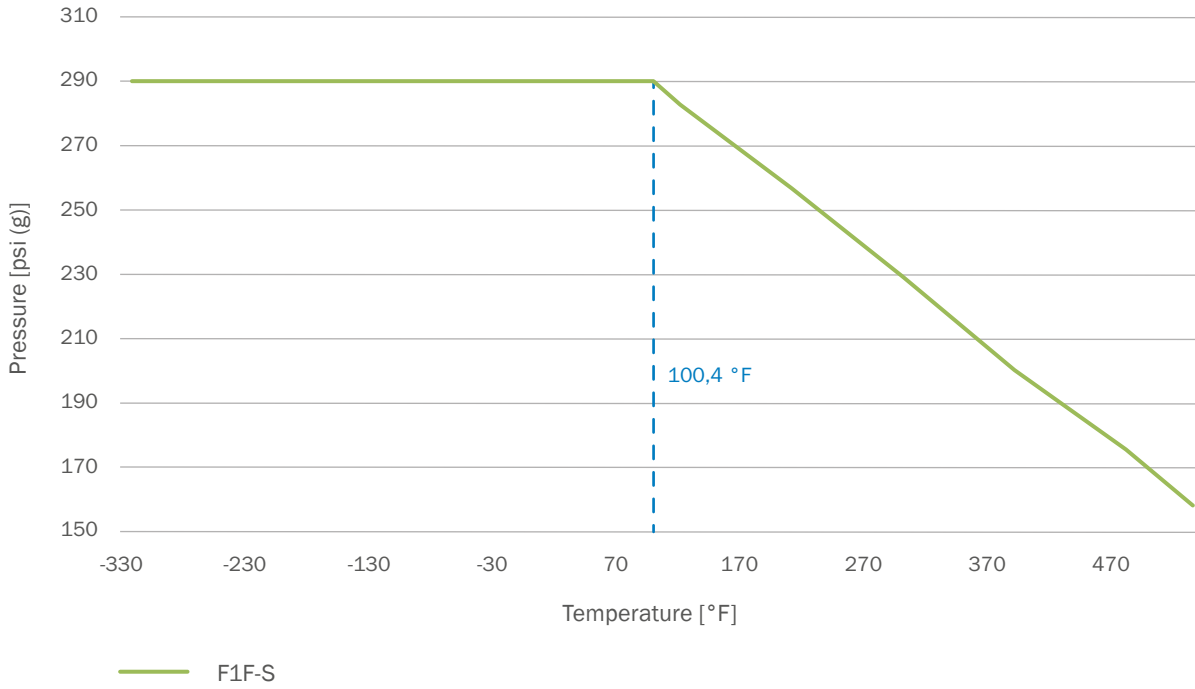

F1F-H

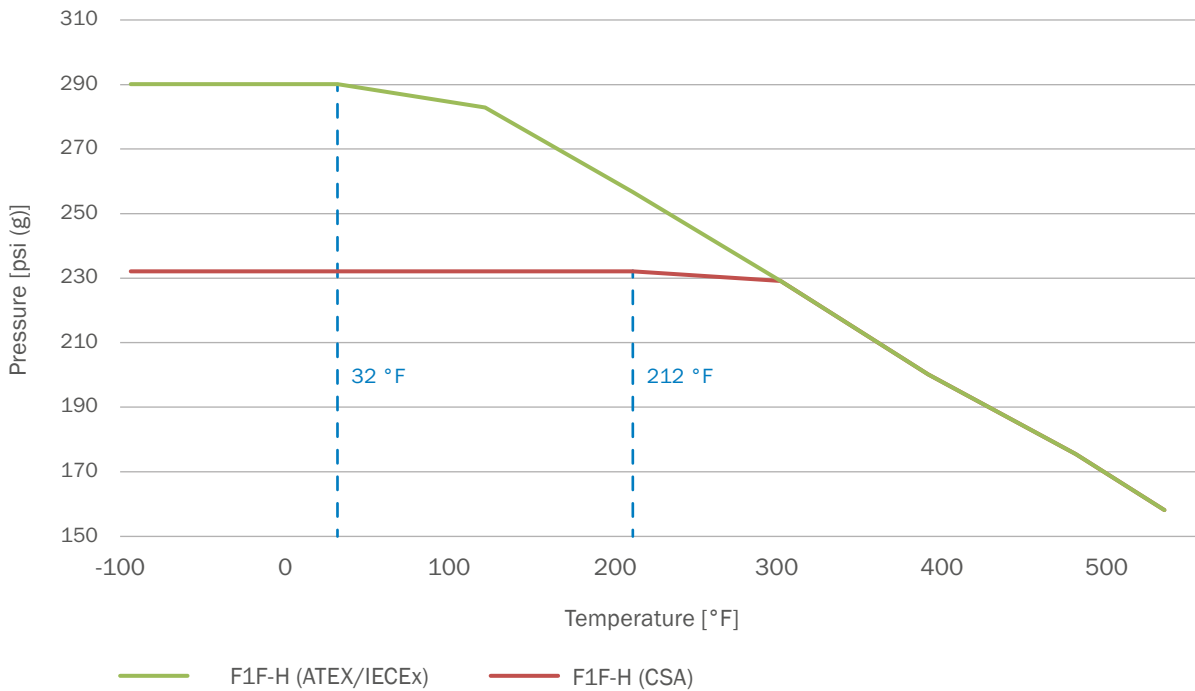

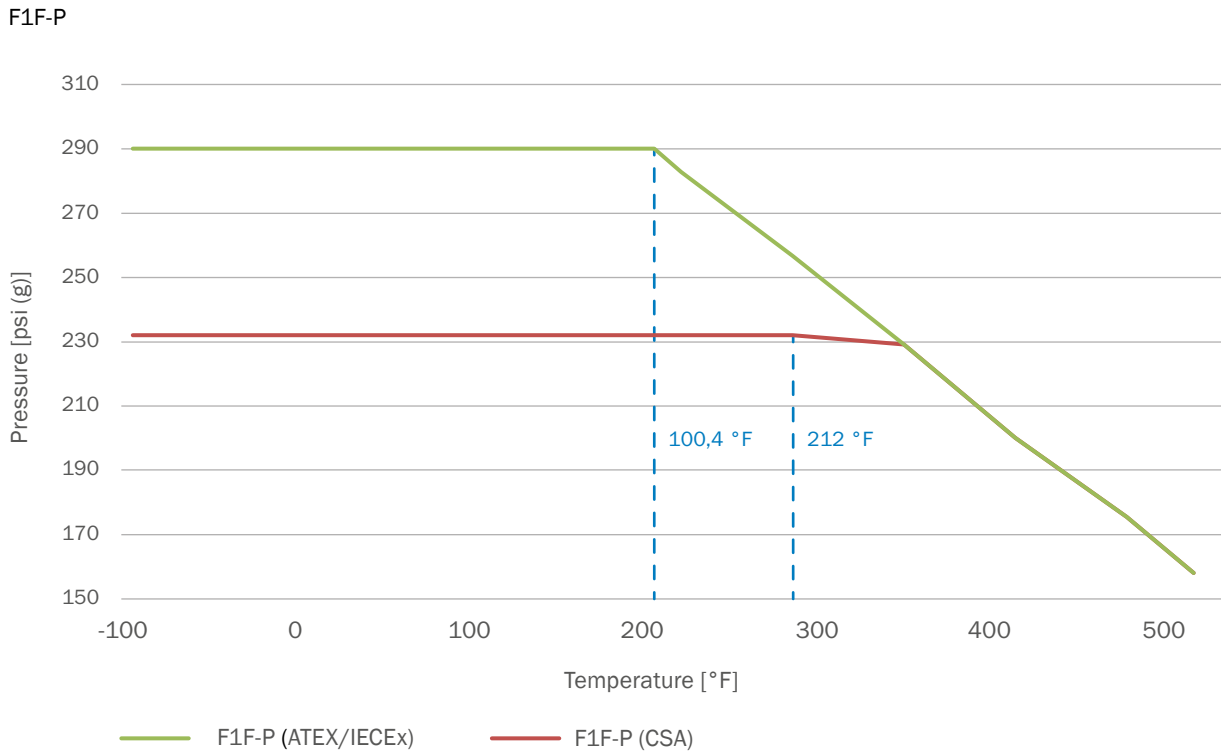

SERVICES FOR MACHINES AND PLANTS: SICK LifeTime Services

Our comprehensive and versatile LifeTime Services are the perfect addition to the comprehensive range of products from SICK. The services range from product-independent consulting to traditional product services.



Consulting and design
Safe and professional



Product and system support
Reliable, fast, and on-site



Verification and optimization
Safe and regularly inspected



Upgrade and retrofits
Easy, safe, and economical



Training and education
Practical, focused, and professional

SICK AT A GLANCE

SICK is a leading manufacturer of intelligent sensors and sensor solutions for industrial applications. With more than 9,700 employees and over 50 subsidiaries and equity investments as well as numerous agencies worldwide, SICK is always close to its customers. A unique range of products and services creates the perfect basis for controlling processes securely and efficiently, protecting individuals from accidents, and preventing damage to the environment.

SICK has extensive experience in various industries and understands their processes and requirements. With intelligent sensors, SICK delivers exactly what the customers need. In application centers in Europe, Asia, and North America, system solutions are tested and optimized in accordance with customer specifications. All this makes SICK a reliable supplier and development partner.

Comprehensive services round out the offering: SICK LifeTime Services provide support throughout the machine life cycle and ensure safety and productivity.

That is “Sensor Intelligence.”

Worldwide presence:

Australia, Austria, Belgium, Brazil, Canada, Chile, China, Czech Republic, Denmark, Finland, France, Germany, Great Britain, Hungary, Hong Kong, India, Israel, Italy, Japan, Malaysia, Mexico, Netherlands, New Zealand, Norway, Poland, Romania, Russia, Singapore, Slovakia, Slovenia, South Africa, South Korea, Spain, Sweden, Switzerland, Taiwan, Thailand, Turkey, United Arab Emirates, USA, Vietnam.

Detailed addresses and further locations → www.sick.com