

**OPERATING PRINCIPLE**

Set in motion with pneumatic energy, the piston moves in an extruded aluminium tube containing a slot running the length of the cylinder. In order to provide a tight seal over the slot length, there are two bands. A stamped steel piston bracket connects the cylinder piston to the carrier bracket. This piston bracket contains special band ramps which unseat and reseat the bands in the slot, providing a sealed unit.

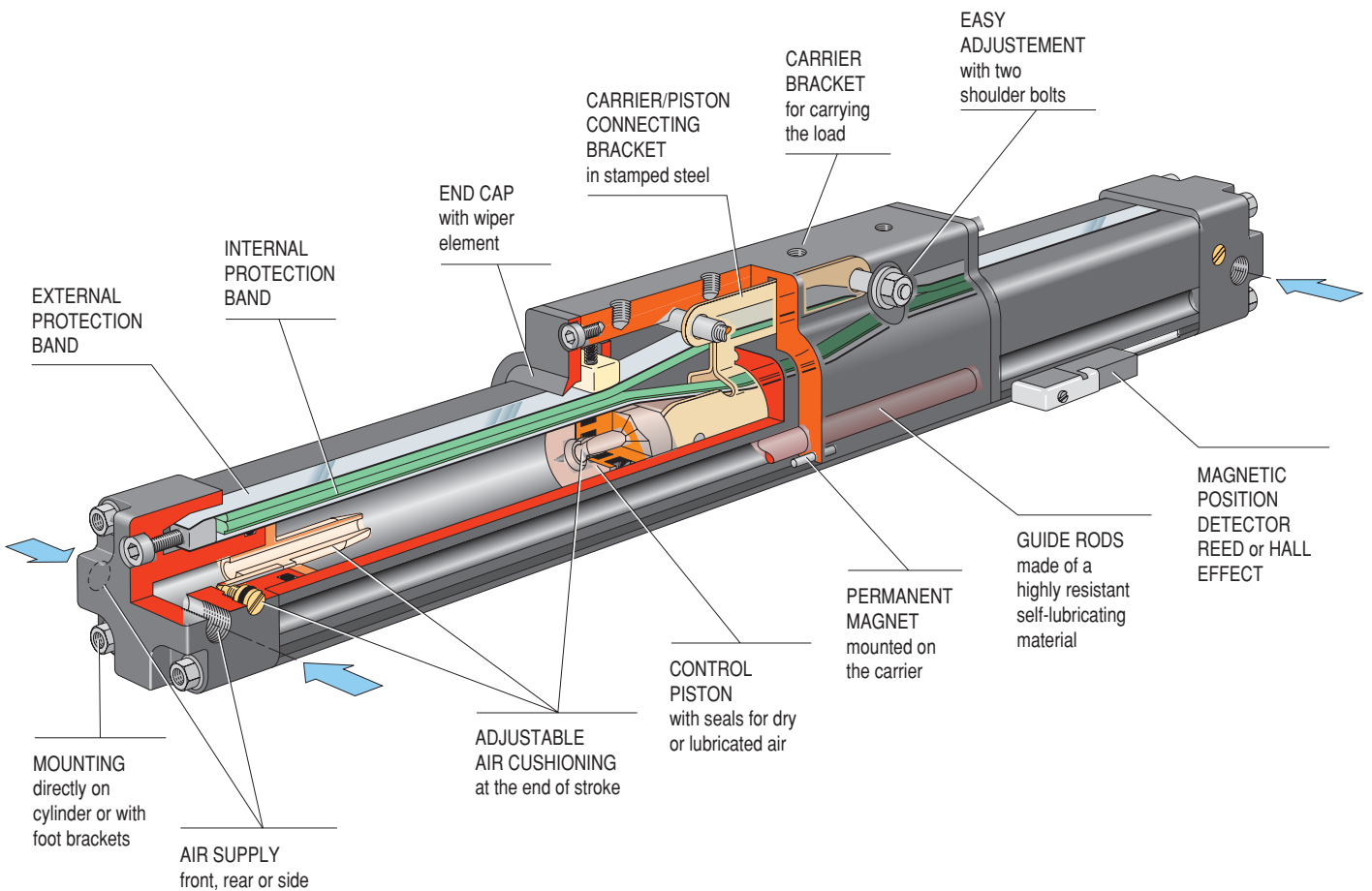

00351GB-2017/R01  
Availability, design and specifications are subject to change without notice. All rights reserved.

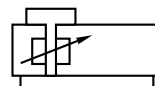

## SPECIFICATIONS

<b>Detection</b>	<b>Equipped or not for magnetic detectors</b>
<b>Fluid</b>	air or neutral gas, filtered, lubricated or not
<b>Pressure</b>	8 bar max
<b>Temperature</b>	-10°C to +65°C
<b>Maximum velocity</b>	2 m/sec
<b>Stroke</b>	

Ø mm	min. stroke	max. stroke
25	100	3400
32	100	3400
40	100	3400
50	100	3400
63	100	3300



## CONSTRUCTION

<b>Tube</b>	Anodized aluminum alloy
<b>Ends</b>	Anodized aluminum alloy
<b>Carrier bracket</b>	Anodized aluminum alloy
<b>Piston</b>	Polyamide/light alloy
<b>Piston seals</b>	Nitrile (NBR)
<b>Piston bracket</b>	High resistance stamped steel
<b>Bandes</b>	Stainless steel with elastomer strips
<b>Magnet</b>	Placed outside the cylinder, on the carrier
<b>Guide rods</b>	Self-lubricating NYLATRON
<b>Cushioning</b>	With air, adjustable

Cushioning length :	Ø 25 mm = 17 mm
	Ø 32 mm = 28 mm
	Ø 40 mm = 32 mm
	Ø 50 mm = 34 mm
	Ø 63 mm = 50 mm



## CHOICE OF EQUIPMENT

Ø Cylinder (mm)	CYLINDER NON EQUIPPED FOR DETECTOR		CYLINDER EQUIPPED FOR DETECTOR			Connection (4)
	CODE	REFERENCE	with Reed switch CODE <sup>(3)</sup>	with Hall effect CODE <sup>(3)</sup>	REFERENCE	
25	44650001 <sup>(1)</sup>	STB 25 A _ (1) _	44650006 <sup>(1)</sup>	44650011 <sup>(1)</sup>	STB 25 A _ (1) _ - DM (A/H) <sup>(2)</sup>	G 1/8
32	44650002 <sup>(1)</sup>	STB 32 A _ (1) _	44650007 <sup>(1)</sup>	44650012 <sup>(1)</sup>	STB 32 A _ (1) _ - DM (A/H) <sup>(2)</sup>	G 1/4
40	44650003 <sup>(1)</sup>	STB 40 A _ (1) _	44650008 <sup>(1)</sup>	44650013 <sup>(1)</sup>	STB 40 A _ (1) _ - DM (A/H) <sup>(2)</sup>	G 1/4
50	44650004 <sup>(1)</sup>	STB 50 A _ (1) _	44650009 <sup>(1)</sup>	44650014 <sup>(1)</sup>	STB 50 A _ (1) _ - DM (A/H) <sup>(2)</sup>	G 3/8
63	44650005 <sup>(1)</sup>	STB 63 A _ (1) _	44650010 <sup>(1)</sup>	44650015 <sup>(1)</sup>	STB 63 A _ (1) _ - DM (A/H) <sup>(2)</sup>	G 3/8

- (1) Specify the stroke (in mm)  
 (2) Cylinder equipped for Reed switch = suffix **DMA**, for Hall effect = suffix **DMH**  
 (3) Position detectors are to be ordered separately (see following pages)  
 (4) 3 types of pneumatic connection : front, rear or side

## MOUNTINGS

 Foot brackets <sup>(5)</sup>	Ø Cylinder (mm)	CODE
	25	43400237
	32	43400238

 Mounting brackets	Ø Cylinder (mm)	CODE
	40	43400239
	50	43400240
	63	43400241

Delivered with two (2) brackets plus cylinder mounting screws  
 The mountings are delivered non assembled  
 (5) Foot brackets for cylinders Ø 25 and 32 allows upward adjustment

## ACCESSORIES

- **Tube support** (recommended to avoid buckling, depending on the stroke and load)
- Shock absorbers
- Floating mount bracket, alignment compensation (for guided load movement only)
- Magnetic detectors: Reed switch (ILS) or Hall effect

## OPTIONS (contact us)

- Stroke limiting device adaptable on cylinder (adjustable stoppers equipped with shock absorbers)
- Double carrier bracket version (for loads and bending moments higher than standard values)

Selecting the appropriate Band Cylinder is simple. The information you need includes:

- the stroke,
- the force required for moving the load,
- the weight of the load,
- the position of the load (centered on the carrier or elsewhere),
- the final or average velocity.

### How to select

Graph (I) represents the theoretical force at various pressures. For the most efficient use of a cylinder, it is recommended to use a load rate of 70 %: the force needed to move the load therefore corresponds to 70% of the theoretical force.

After defining the cylinder diameter, you must determine if the cylinder's internal cushions may be used.

### Allowable Bending Moments

If the load is not centered on the carrier, there will be bending moment. (see bending moment data below).

### THEORETICAL FORCE AT VARIOUS PRESSURES

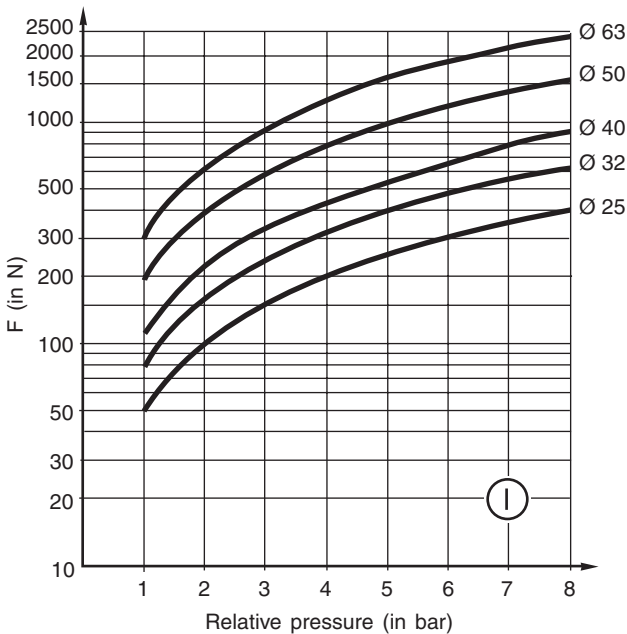

### Cushioning capacity

Graph (II) is used to determine the type of cushioning needed. If the intersection point of the final velocity and the load falls below the curves, the internal cushions are adequate. If this is not the case, you must either choose a larger cylinder with greater cushion capacity, or use the shock absorbers which are offered as accessories. If you have determined that the internal cushions would be used near their maximum capacity **and** there is highly intense movement, it would be wise to use the optional shock absorbers.

### OTHER ACCESSORIES :

- Tube support brackets: **You must determine if intermediate tube support brackets are required**, depending on the weight of the charge and the stroke. (see chart on tube support sheet)
- Floating mount bracket: for use when there is a lack of parallelism between the cylinder and a guided and supported load.
- Reed switch or Hall Effect magnetic detectors for position control.

### CUSHION DATA

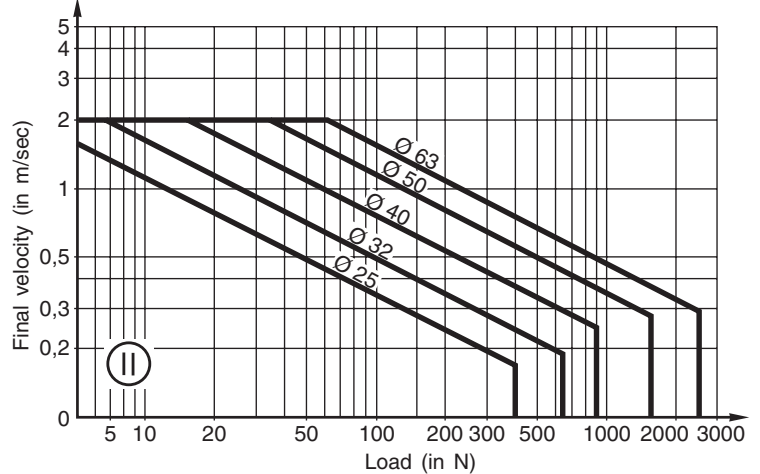

The velocities indicated in graph (II) represent final velocities. To properly determine the inertial forces for cushioning, it is important to know the **final velocity**. If final (or impact) velocity cannot be calculated directly, a reasonable guideline is :

$final V = 2 \times average\ velocity$

### ALLOWABLE BENDING MOMENTS

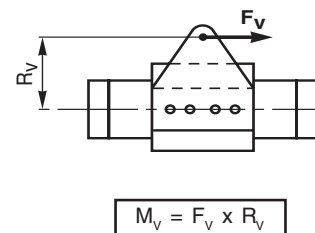
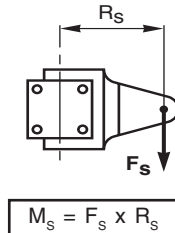
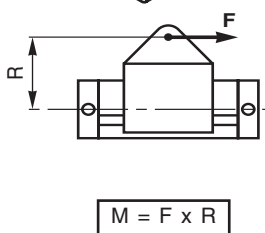
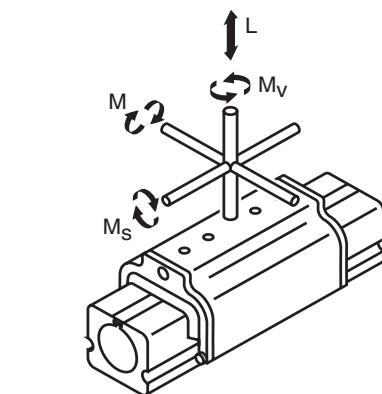

Ø Cylinders (mm)	Bending moments (in N.m)			Load (in N)
	M	Ms	Mv	
25	11	6	3.5	270
32	33	8.5	15	540
40	56	31	23	820
50	125	34	37	1360
63	200	51	45	1820

Greater performances possible with the **double carrier bracket** version (contact us)

**DIMENSIONS (mm), WEIGHT (kg)**

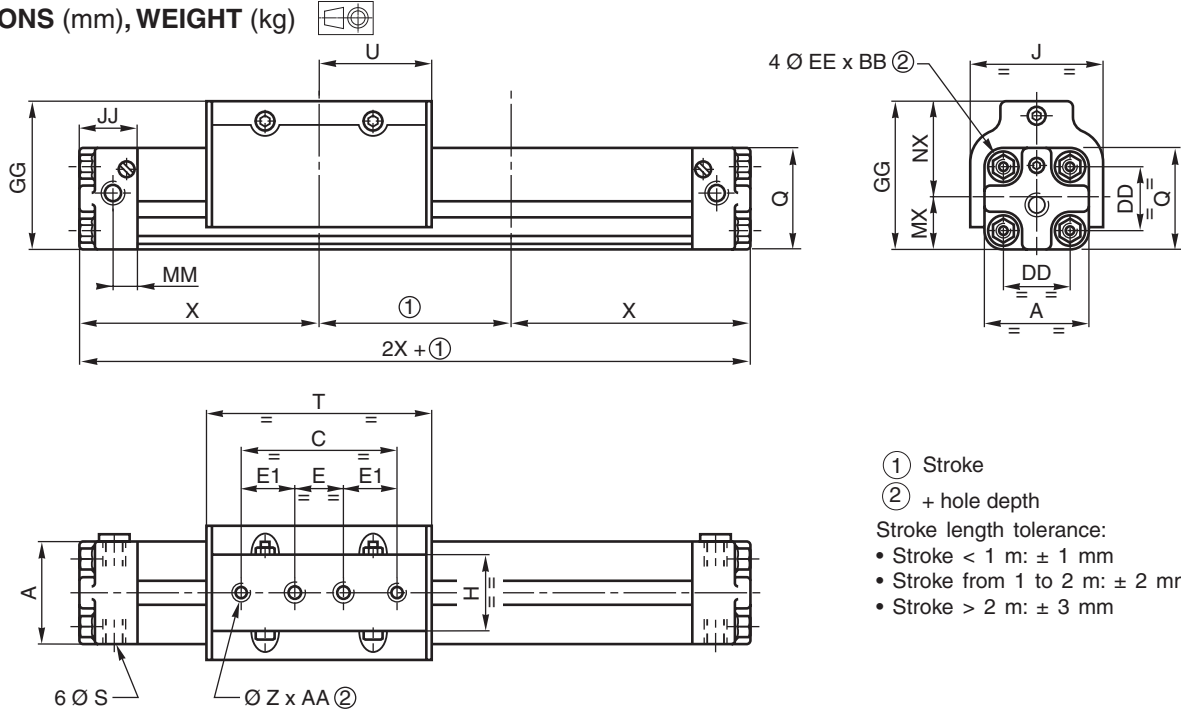

- ① Stroke
  - ② + hole depth
- Stroke length tolerance:
- Stroke < 1 m: ± 1 mm
  - Stroke from 1 to 2 m: ± 2 mm
  - Stroke > 2 m: ± 3 mm

Ø (mm)	A	AA	BB	C	DD	E	E1	EE	GG	H	J	JJ	MM	MX	NX	Q	S	T	U	X	Z	weight	
																						(1)	(2)
25	40,1	6	11	80,0	27,9	25,4	27,3	M5x11	58,4	33,0	55,4	25,4	14,0	20,3	38,1	41,5	G1/8	120,7	60,2	100,1	M6x6	1,020	0,0024
32	55,4	7	12	81,3	36,1	25,4	28,0	M6x12	77,7	39,6	71,6	25,4	8,6	31,2	46,5	57,2	G1/4	117,9	58,9	123,7	M8x7	2,068	0,0036
40	72,4	10	12	107,7	46,0	25,4	41,2	M6x12	90,7	45,7	89,0	31,8	12,7	36,6	54,1	65,8	G1/4	150,1	75,1	150,1	M8x10	3,700	0,0058
50	82,6	11	25	127,0	57,2	63,5	31,8	M8x25	112,8	58,4	112,8	36,6	17,5	42,9	69,9	85,9	G3/8	187,2	93,5	160,0	M10x11	6,400	0,0093
63	108,0	12	25	152,4	73,2	76,2	38,1	M8x25	139,7	64,8	142,8	52,3	25,4	58,4	81,3	111,0	G3/8	225,0	112,5	214,6	M10x12	14,467	0,0173

(1) Cylinder weight at 0 mm stroke.  
 (2) Weight to be added per additional 100 mm length.

**CYLINDERS WITH MOUNTING BRACKETS**

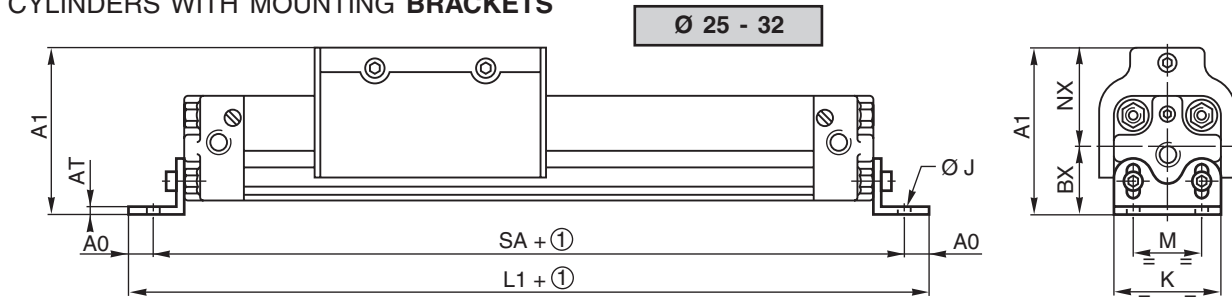

Ø Cylinder (mm)	DIMENSIONS (mm)										Weight (kg) Mounting		
	A1		A0	AT	BX		J	K	L1	M		NX	SA
25	min. 59,7	max. 69,3	9,5	3	min. 21,6	max. 31,2	6,6	41	251	27	38,1	231,8	0,090
32	min. 81,5	max. 94,2	9	3	min. 33,2	max. 46	8,3	53	292	36	48,3	273,8	0,130

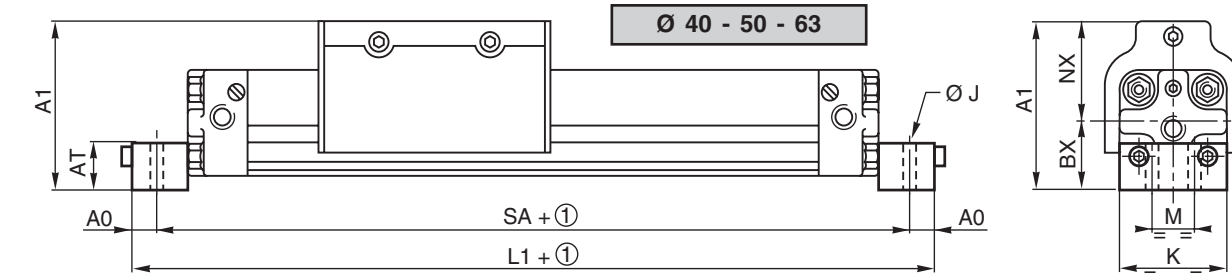

Ø Cylinder (mm)	DIMENSIONS (mm)										Weight (kg) Mounting
	A1	A0	AT	BX	J	K	L1	M	NX	SA	
40	92	12,7	25	34,7	8,3	72	351	30	57,3	325,5	0,270
50	115	12,7	22	42	9,9	83	371	31,8	73,1	345,5	0,270
63	143,5	15	25	54,3	11	108	490	48	89,2	460	0,400

For certain strokes and loads, it is necessary to use tube support brackets for intermediate support. The graph below is used to determine the maximum allowable length. The number of tube support brackets required and their placement, depends on the overall length of the cylinder and the load weight being moved and supported.

These brackets are made of black-anodized aluminum and are designed to fit into dovetail grooves which run the length of the cylinder tube. They are **delivered mounted** on the cylinder; therefore, **they must be ordered with the cylinder**

Note : These support brackets cannot be mounted in the same place as the magnetic detector, as they use the same grooves.

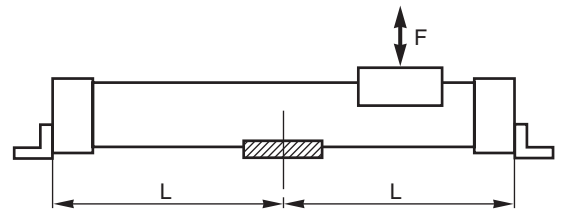
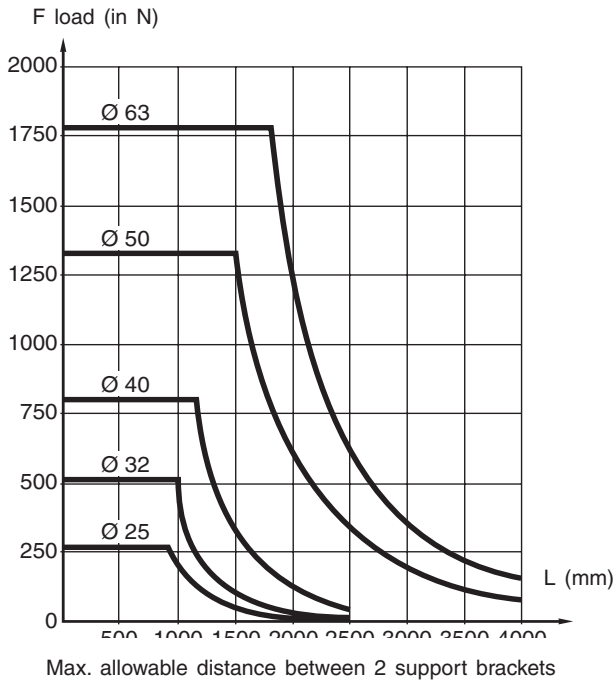

Number of supports needed (n) given that the cylinder is fixed on the ends.

$$n = \left( \frac{\text{Stroke} + 2 X}{L} \right) - 1$$

- n = whole number, rounded up.
- X = value in mm, mentioned with general cylinder dimensions
- L = max. distance defined in the graph below.

## CODES - DIMENSIONS AND WEIGHTS

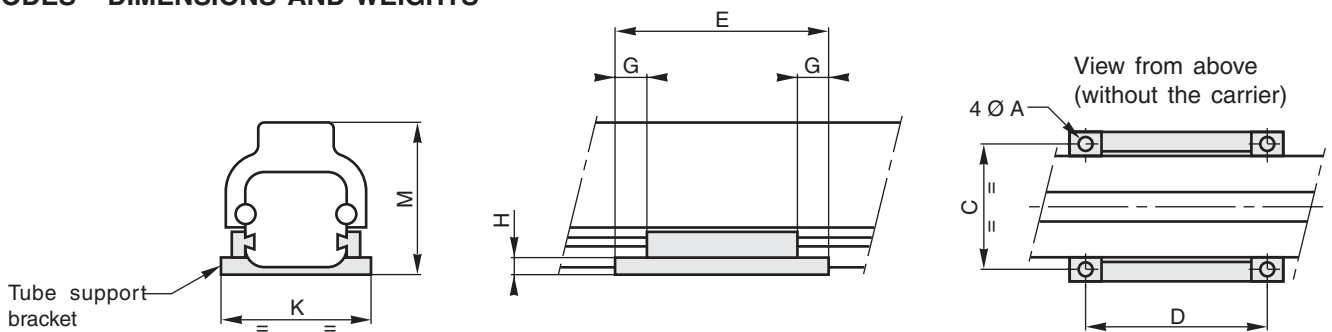

Ø Cylinder (mm)	CODE <sup>(1)</sup>				DIMENSIONS (mm)								Weight (kg) for 1 support bracket
	1 support bracket	2 support brackets	3 support brackets	4 support brackets	A	C	D	E	G	H	K	M	
25	410528	410529	410530	410531	5,6	51	76,2	90	13	6,5	60	62	0,180
32	410532	410533	410534	410535	6,7	66,7	114,3	127	13	10	79	82	0,220
40	410536	410537	410538	410539	6,7	76,2	114,3	127	13	8	89	92	0,220
50	410540	410541	410542	410543	10,5	95,3	146	162	17,5	9,5	113	115	0,350
63	410544	410545	410546	410547	10,7	130	197	216	19	11	152,5	143,5	0,600

(1) These codes are added to the cylinder codes

The standard rodless band cylinder cushion is an effective method for load deceleration. However, the band cylinder can bear heavier loads at higher velocities than that of which the cylinder cushion can absorb. Shock absorbers are used to increase the cylinder's service life and broaden the application range for the chosen cylinder. Shock absorbers can be mounted directly on the cylinder.

### Selecting the necessary absorber :

- 1- Define the following values:
  - Weight of load being moved (in N).
  - Final **velocity** (in m/sec).
  - Cycles per hour.
- 2- In the graph below, determine the type of absorber in relation to the diameter of the cylinder chosen.  
 Cross reference the intersection of final velocity and load weight to determine which shock absorber is required : type 1 or type 2.
- 3- To complete the shock absorber selection, you must consider the cycles per hour for your application. Since shock absorbers convert kinetic energy of a load into heat, it is important not to exceed the maximum allowable cycles listed in the adjacent table.

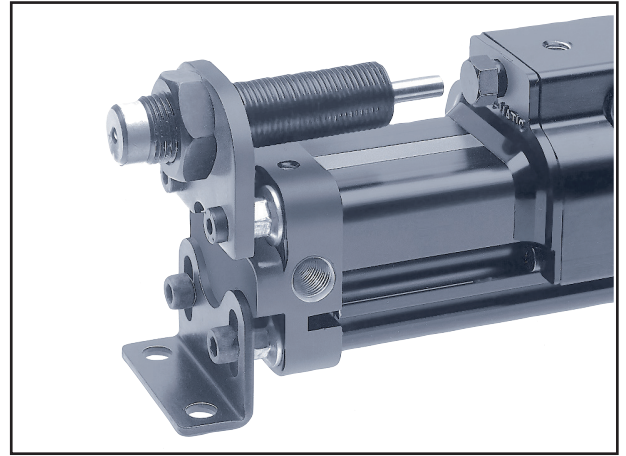

MAXIMUM CYCLE PER HOUR CAPACITY	
Models	Cycles per hour
Absorbers for cylinder Ø 25	1200
Absorbers for cylinder Ø 32	1000
Absorbers for cylinder Ø 40	1000
Absorbers for cylinder Ø 50	800
Absorbers for cylinder Ø 63	800

### CODES

DESIGNATION		CODES <sup>(1)</sup>	
		Absorbers type 1	Absorbers type 2
Set of two (2) shock absorbers (delivered <b>mounted on</b> the cylinder)	Ø 25 mm	<b>560569</b>	<b>560572</b>
	Ø 32 mm	<b>560570</b>	<b>560573</b>
	Ø 40 mm	<b>560577</b>	<b>560579</b>
	Ø 50 mm	<b>560571</b>	<b>560574</b>
	Ø 63 mm	<b>560578</b>	<b>560580</b>

(1) Code to be added to the standard cylinder code

### SIZE AND DIMENSIONS

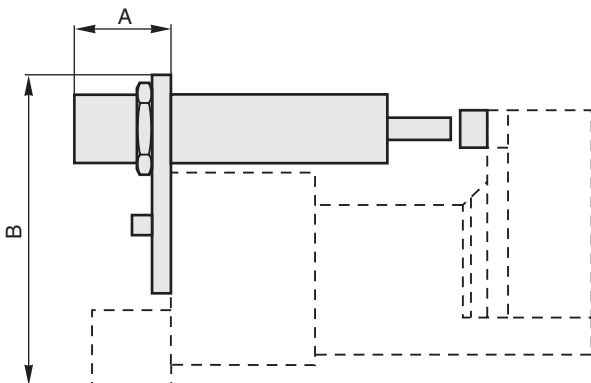

Ø Cylinder (mm)	A	B		Weight (kg) 2 absorbers + mountings
		min.	max.	
<b>25</b>	40,5	64	73,5	0,200
<b>32</b>	29,5	90	102,5	0,430
<b>40</b>	28	104		0,570
<b>50</b>	58,5	123,5		0,780
<b>63</b>	24,5	162,5		0,920

**You must not adjust the position of the absorbers**



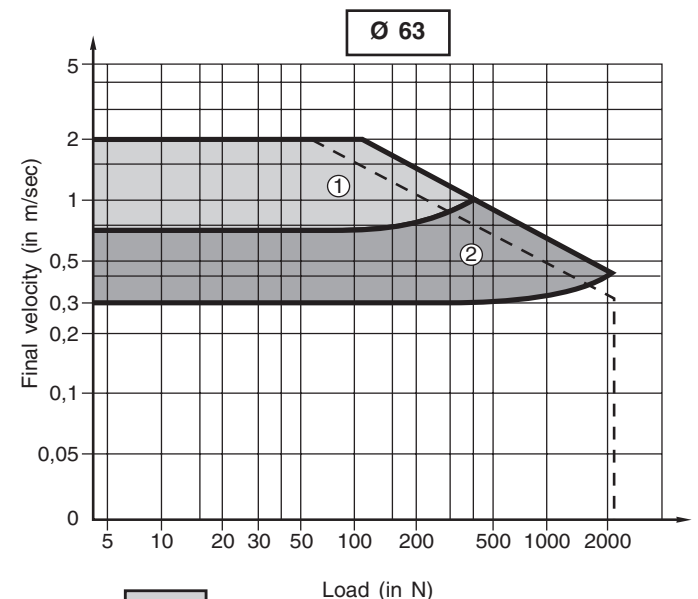
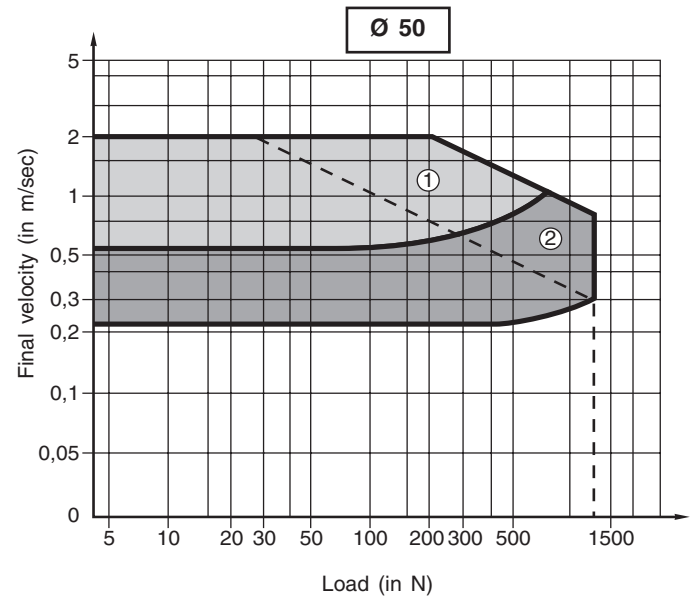
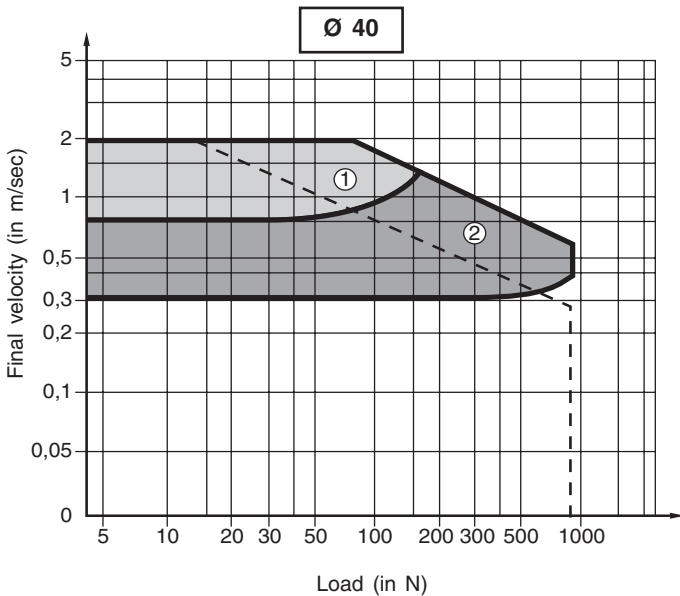
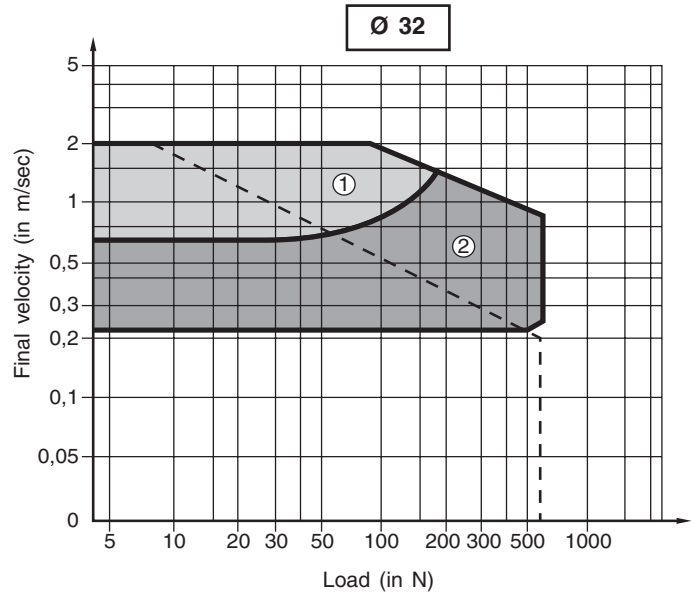
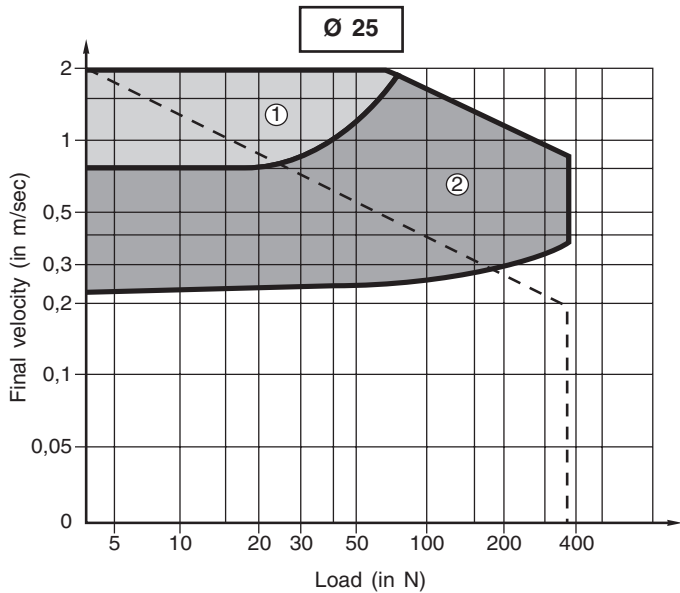

- ① Zone using type 1 absorber
- ② Zone using type 2 absorber

To properly determine the inertial forces for cushioning, it is important to know the final velocity. If the final velocity cannot be calculated directly, a reasonable guideline is:

**Final velocity = 2 x average speed**

For each cylinder diameter, the intersection of the final speed and the load weight indicates which type of absorber to use.

The dotted line represents the limit between choosing the air cushions or shock absorbers. If you have determined that the internal cushions would be used near their maximum capacity **and** there is highly intense movement, it would be wise to use the optional shock absorbers.

The above graphs were established for cylinders working on a horizontal plane and at 6 bar.

*For applications exceeding cycle capability, please contact us.*

For applications where a band cylinder moves a load that is externally guided and supported, a floating mount bracket is necessary to compensate for non-parallelism between the cylinder and the independent guiding member.

Alignment of compensation  $\updownarrow$  :  $\pm U$

$\leftrightarrow$  :  $\pm M$

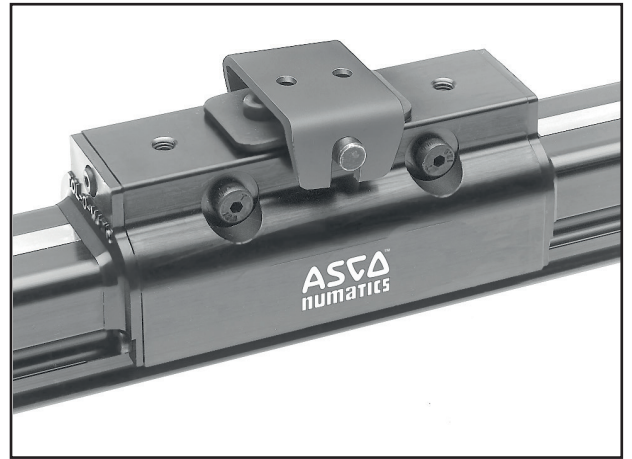

For cylinders  
 $\varnothing$  25 - 32 - 50

For cylinders  
 $\varnothing$  40 - 63

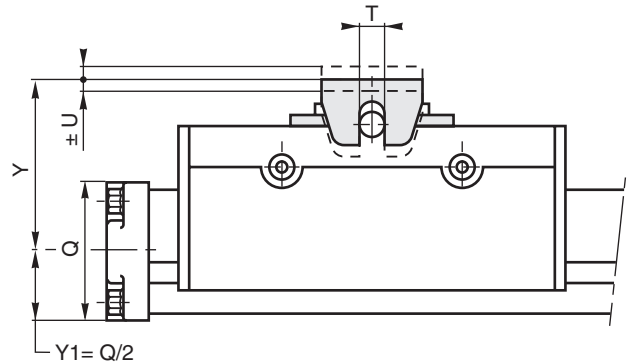
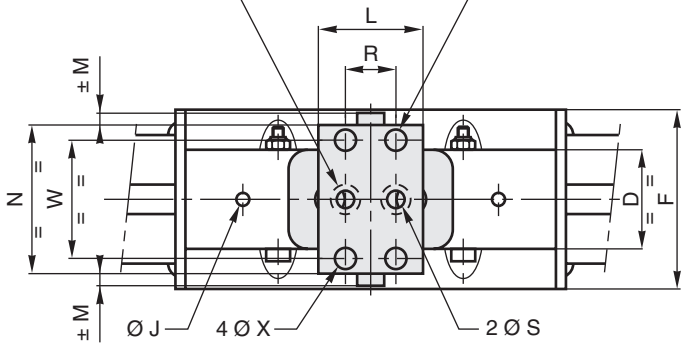
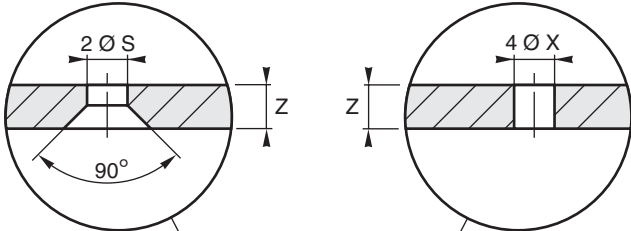

$\varnothing$ Cylinder (mm)	MOUNT BRACKET CODE	DIMENSIONS (mm)														Weights Mount Bracket (kg)		
		D	F	$\varnothing$ J	L	$\pm$ M	N	R	$\varnothing$ S	T	$\pm$ U	W	4 $\varnothing$ X	Y	Y1		Q	Z
25	43400232	33	55,5	M6	32	3,3	46	15,7	5,6	8	3,8	-	-	50,5	20,5	41	3	0,110
32	43400233	40	71,5	M8	70	4	56	50	7	8	4	-	-	66	28,5	57	4	0,250
40	43400234	46	89	M8	90	7	75	75	-	11	6	55	7	75	33	66	7	0,540
50	43400235	58	113	M10	100	7	82	80	8,6	16	6,4	-	-	96	43	86	5	0,610
63	43400236	65	143	M10	120	12	98	100	-	16	7	70	8,6	102	54	108	5	0,730

Floating mount bracket mounting screws are supplied.

**You must use LOCTITE 241 for the carrier bracket mounting screws.**





direct  
current

### OPERATION

A permanent magnet mounted on the carriage passes in the vicinity of the reed switch and operates it without contact. One or more detectors can be mounted on the cylinder to detect the end of stroke position is reached. Reed switches are engaged in the longitudinal dovetail groove in the cylinder body. They are equipped with an indicator light which illuminates when contact is broken.

Passing an intermediate position by the piston can be detected with a solid-state sensor, see overleaf

### ELECTRICAL CHARACTERISTICS

SWITCHING POWER	: 10 W max.
SWITCHING VOLTAGE	: 3 to 200 Vdc (1) (2)
SWITCHING CURRENT	: 500 mA
CONTACT RESISTANCE	: 100 mΩ
WITHSTAND VOLTAGE	: 200 V
REPOSE TIME	: < 0,6 ms
SERVICE LIFE	: until 2x10 <sup>8</sup> operations (depending on the load)
TEMPERATURE	: -40° C to + 70° C
ELECTRICAL PROTECTION	: See chart
HOUSING	: Polyamide
CONNECTION	: One Ø 4 mm cable - 5 m long - 2 conductors 0,30 mm <sup>2</sup>
INDICATOR LAMP	: Red diode (LED) which lights up when the contact is closed (I min.: 4mA)

(1) The indicator lamp gives a voltage drop of approx. 3 V.



**Nota :** The operating point must be in the shaded zone. Exceeding the voltage or amperage levels can destroy the switches

### PROTECTION

**Polarity for DC :**  
Brown wire = pôle +  
Blue wire = pôle -

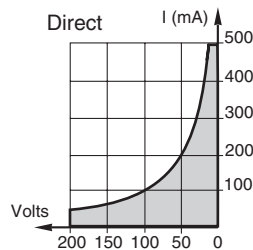

INDUCTIVE CHARGE		Diode 400 V / 1 A
OHMIC CHARGE		Protection unnecessary

The user is responsible for supplying and assembling diode.

### CODES FOR REED SWITCH

CODES (2 codes to specify : detector + fastening kit)		
REED SWITCH DETECTOR with wire outlet, 5m long	Ø cylinder	STB cylinder FASTENING KIT
<b>88144658</b>	25	<b>88144662</b>
	32	<b>88144663</b>
	40	<b>88144664</b>
	50	<b>88144664</b>
	63	<b>88144663</b>

(2) Detector for alternating current (120 V and 3 W max., without reed): **88144676**

### PARTICULAR CASE

Detectors used for direct control of incandescent lamps:  
The power indicated in the lamp is based on its resistance when hot. The resistance is very low when turned on with the lamp cold and the amperage can become very high and may exceed the ILS rating. Allowance should therefore be made for the actual wattage of the bulb when cold. (see diagram)

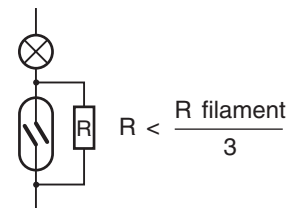

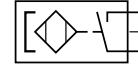

**OPERATION**

Solid-state sensors are magnetically-operated devices which open and close DC circuits and, having no moving parts, have theoretically unlimited service lives. Solid state sensors are engaged in the cylinder body groove and can be used to detect reaching end-of-stroke positions or any intermediate ones.

**ELECTRICAL CHARACTERISTICS**

- SWITCHING VOLTAGE : 5 to 25 Vdc
- MAX. SWITCHING CURRENT : 200 mA
- WITHSTAND VOLTAGE : 300 V
- SATURATION : 5 V max.
- REPOSE TIME : 2 μs
- SENSITIVITY : 20 to 135 gauss max.
- TEMPERATURE : - 18° C to + 66° C
- HOUSING : Polyamide
- CONNECTION : One Ø 4 mm cable - 5 m long - 3 conductors 0,30 mm<sup>2</sup>
- INDICATOR : Red diode (LED) which lights up during switching
- ELECTRIC PROTECTION : Detector polarized, unprotected against short circuits and over voltage.  
Protection on inductive circuit : Use of a 600 V/1 A diode is recommended, to be mounted parallel to the load.

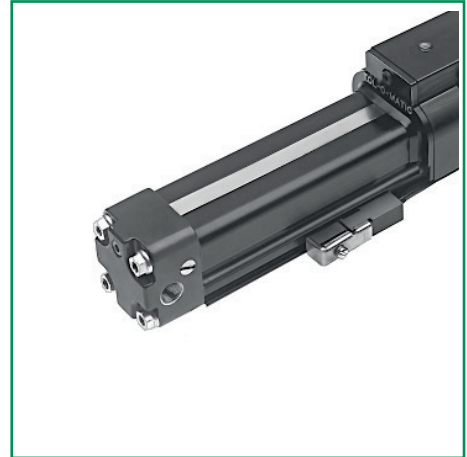

**CONNECTION**

- **SOURCING** (switching positive potential of the charge)
- Max. Power : 0.2 A under 25 Vdc.
- The detector is conceived to supply a signal to equipment such as a PLC. (relay not recommended).

**SOURCING** function detector

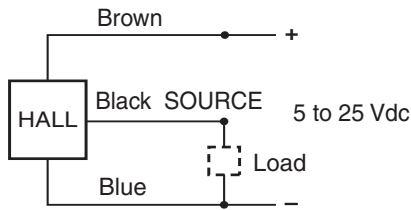

**CODES FOR HALL EFFECT SWITCHES**

CODES (2 codes to specify : detector + fastening kit)		
HALL EFFECT DETECTOR with outlet wire, 5m long SOURCING function	Ø cylinder	STB cylinder FASTENING KIT
<b>88144659</b>	25	<b>88144662</b>
	32	<b>88144663</b>
	40	<b>88144664</b>
	50	<b>88144664</b>
	63	<b>88144663</b>