**User's
Manual**

**AXF
Magnetic Flowmeter
Integral Flowmeter/
Remote Flowtube
[Hardware Edition]**

ADMAG AXF™

IM 01E20D01-01E

vigilantplant®

Contents

1. INTRODUCTION	1-1
1.1 Using the Magnetic Flowmeter Safely	1-2
1.2 Warranty	1-4
1.3 Combination Remote Converters	1-4
2. HANDLING PRECAUTIONS	2-1
2.1 Checking Model and Specifications	2-1
2.2 Accessories	2-1
2.3 Storage Precautions	2-2
2.4 Installation Location Precautions	2-2
3. INSTALLATION	3-1
3.1 Piping Design Precautions	3-1
3.2 Handling Precautions	3-3
3.2.1 General Precautions	3-3
3.2.2 Flowmeter Piping	3-4
3.3 Mounting Procedures	3-4
3.3.1 Nominal Diameter 2.5 mm (0.1 in.) to 10 mm (0.4 in.), Union Joint Type	3-4
3.3.2 Nominal Diameter 2.5 mm (0.1 in.) to 40 mm (1.5 in.), Wafer Type	3-6
3.3.3 Nominal Diameter 50 mm (2.0 in.) to 300 mm (12.0 in.), Wafer Type	3-11
3.3.4 Nominal Diameter 2.5 mm (0.1 in.) to 400 mm (16 in.), Flange Type	3-15
3.3.5 Gaskets Size	3-18
3.3.6 Nominal Diameter 15 mm (0.5 in.) to 125 mm (5.0 in.), Sanitary Type	3-19
4. WIRING	4-1
4.1 Wiring the Integral Flowmeter	4-1
4.1.1 Wiring Precautions	4-1
4.1.2 Power Cable/Output Cable	4-1
4.1.3 Wiring Ports	4-2
4.1.4 Wiring Connections	4-3
4.2 Wiring the Remote Flowtube	4-8
4.2.1 Wiring Precautions	4-8
4.2.2 Cables	4-9
4.2.3 Wiring Ports	4-10
4.2.4 Wiring Connections	4-11

5.	MAINTENANCE	5-1
5.1	Changing Direction of Electrical Connection	5-1
5.2	Removing, Cleaning, and Installing Replaceable Electrodes (General-Purpose Use Type Only)	5-2
5.2.1	Removing Replaceable Electrodes	5-2
5.2.2	Cleaning Replaceable Electrodes	5-3
5.2.3	Installing Replaceable Electrodes	5-4
5.3	Removing and Installing Adapters for Sanitary Types	5-5
5.4	Maintenance for Converter (Integral Flowmeter Only)	5-7
5.4.1	Fuse Replacement	5-7
5.4.2	Changing the Direction of the Display Unit	5-7
5.5	Setting of Switches (Integral Flowmeter Only)	5-8
5.5.1	Setting of Burnout Switch	5-8
5.5.2	Setting of Write Protect Switch	5-8
5.6	Regular Inspection Items	5-9
5.7	Excitation Coil and Insulation Resistance Check (Remote Flowtube Only)	5-9
5.8	Maintenance of the LCD Display	5-9
5.9	Troubleshooting	5-10
5.9.1	No Indication	5-10
5.9.2	Unstable Zero	5-11
5.9.3	Disagreement Between Indication and Actual Flow	5-12
6.	OUTLINE	6-1
7.	PED (PRESSURE EQUIPMENT DIRECTIVE)	7-1
8.	EXPLOSION PROTECTED TYPE INSTRUMENT	8-1
8.1	ATEX	8-1
8.2	FM	8-1
8.3	CSA	8-3
8.4	IECEX	8-5
8.5	TIIS	8-5

**INSTALLATION AND OPERATING PRECAUTIONS
FOR TIIS FLAMEPROOF EQUIPMENT EX-B03E**

REVISION RECORD

1. INTRODUCTION

This instrument has been adjusted at the factory before shipment.

To ensure correct use of the instrument, please read this manual thoroughly and fully understand how to operate the instrument before operating it.



NOTE

This manual describes the hardware configuration of integral flowmeter and remote flowtube of the AXF magnetic flowmeters.

For details of the “basic operating procedures”, “parameter description”, “operation via BRAIN terminal (BT200)”, “operation via HART communicator”, and “actual operation” for the AXF integral flowmeter, see the user’s manual of the AXF Integral Flowmeter [Software Edition] (IM 01E20C02-01E).

For FOUNDATION Fieldbus protocol (Converter Output Signal and Communication suffix code; -F), please refer to IM 01E20F02-01E.

For PROFIBUS PA protocol (Converter Output Signal and Communication suffix code; -G), please refer to IM 01E20F12-01E.



NOTE

For details of the AXFA11G magnetic flowmeter converter, see the IM 01E20C01-01E instruction manual. For details of the AXFA14G and AXFA14C magnetic flowmeter converter, see the IM 01E20C02-01E instruction manual.



NOTE

When describing the model name like AXF□□□C in this manual, “□□□” means any of the following.

002, 005, 010, 015, 025, 032, 040, 050, 065, 080, 100, 125, 150, 200, 250, 300, 350, 400

■ Regarding This User’s Manual

- This manual should be provided to the end user.
- Before use, read this manual thoroughly to comprehend its contents.
- The contents of this manual may be changed without prior notice.

- All rights are reserved. No part of this manual may be reproduced in any form without Yokogawa’s written permission.
- Yokogawa makes no warranty of any kind with regard to this material, including, but not limited to, implied warranties of merchantability and suitability for a particular purpose.
- All reasonable effort has been made to ensure the accuracy of the contents of this manual. However, if any errors or omissions are found, please inform Yokogawa.
- Yokogawa assumes no responsibilities for this product except as stated in the warranty.
- Please note that this user’s manual may not be revised for any specification changes, construction changes or operating part changes that are not considered to affect function or performance.
- If the customer or any third party is harmed by the use of this product, Yokogawa assumes no responsibility for any such harm owing to any defects in the product which were not predictable, or for any indirect damages.

■ Safety and Modification Precautions

- The following general safety precautions must be observed during all phases of operation, service, and repair of this instrument. Failure to comply with these precautions or with specific WARNINGS given elsewhere in this manual violates safety standards of design, manufacture, and intended use of the instrument. Yokogawa assumes no liability for the customer’s failure to comply with these requirements. If this instrument is used in a manner not specified in this manual, the protection provided by this instrument may be impaired.
- Yokogawa will not be liable for malfunctions or damage resulting from any modification made to this instrument by the customer.
- The following safety symbol marks are used in this user’s manual and instrument.



WARNING

A WARNING sign denotes a hazard. It calls attention to procedure, practice, condition or the like, which, if not correctly performed or adhered to, could result in injury or death of personnel.

 **CAUTION**





A CAUTION sign denotes a hazard. It calls attention to procedure, practice, condition or the like, which, if not correctly performed or adhered to, could result in damage to or destruction of part or all of the product.

 **IMPORTANT**

An IMPORTANT sign denotes that attention is required to avoid damage to the instrument or system failure.

 **NOTE**

A NOTE sign denotes information necessary for essential understanding of operation and features.

-  Protective grounding terminal
-  Functional grounding terminal
(This terminal should not be used as a protective grounding terminal.)
-  Alternating current
-  Direct current

1.1 Using the Magnetic Flowmeter Safely

(1) Installation

 **WARNING**

- Installation of the magnetic flowmeter must be performed by expert engineer or skilled personnel. No operator shall be permitted to perform procedures relating to installation.
 - The magnetic flowmeter must be installed within the specification conditions.
 - The magnetic flowmeter is a heavy instrument. Be careful that no damage is caused to personnel through accidentally dropping it, or by exerting excessive force on the magnetic flowmeter. When moving the magnetic flowmeter, always use a trolley and have at least two people carry it.
 - When the magnetic flowmeter is processing hot fluids, the instrument itself may become extremely hot. Take sufficient care not to get burnt.
 - Where the fluid being processed is a toxic substance, avoid contact with the fluid and avoid inhaling any residual gas, even after the instrument has been taken off the piping line for maintenance and so forth.
 - Do not apply excessive weight, for example, a person stepping on the magnetic flowmeter.
 - All procedures relating to installation must comply with the electrical code of the country where it is used.
-

(2) Wiring

 **WARNING**

- The wiring of the magnetic flowmeter must be performed by expert engineer or skilled personnel. No operator shall be permitted to perform procedures relating to wiring.
 - When connecting the wiring, check that the supply voltage is within the range of the voltage specified for this instrument before connecting the power cable. In addition, check that no voltage is applied to the power cable before connecting the wiring.
 - The protective grounding must be connected securely at the terminal with the  mark to avoid danger to personnel.
-

(3) Operation

**WARNING**

- When opening the cover, wait for more than 10 minutes after turning off the power. Only expert engineer or skilled personnel are permitted to open the cover.
- Do not open the cover in wet weather or humid environment. When the cover is open, stated enclosure protection is not applicable.
- Be sure to set parameters as “Protect” on the write protect function after finish of parameter setting work.

Under extremely rare case, the infra-red switches may respond unexpectedly in such conditions as sticking ball of water or extraneous substances on the surface of display panel glass according to the principle of infra-red switch operation.

Its probability rises in such cases as sticking rain water by storm or other similar situation and washing up work near flowmeter installation place.

Either to illuminate or stop illuminating the infra-red switches by the flashlight may cause the malfunction.

Refer to “Parameter Description” in the manual IM 01E20C02-01E and Subsection 5.5.2 reading the write protect function in detail.

(4) Maintenance

**WARNING**

- Maintenance of the magnetic flowmeter should be performed by the trained personnel having knowledge of safety standard. No operator shall be permitted to perform any operations relating to maintenance.
- When opening the cover, wait for more than 10 minutes after turning off the power.
- Do not open the cover in wet weather or humid environment. When the cover is open, stated enclosure protection is not applicable.
- Always conform to maintenance procedures outlined in this manual. If necessary, contact Yokogawa.
- Care should be taken to prevent the buildup of dirt, dust or other substances on the display panel glass or name plate. If these surfaces do get dirty, wipe them clean with a soft dry cloth.

(5) Explosion Protected Type Instrument

**WARNING**

- Magnetic flowmeters with the model name AXF□□□C are products which have been certified as explosion proof type instruments. Strict limitations are applied to the structures, installation locations, external wiring work, maintenance and repairs, etc. of these instruments. Sufficient care must be taken, as any violation of the limitations may cause dangerous situations.
Be sure to read Chapter 8 before handling the instruments. The description in Chapter 8 is prior to the other description in this user’s manual.
For ATEX or IECEx explosion proof type, be sure to read IM 01E20A01-11EN.
For TIIS explosion proof type, be sure to read “INSTALLATION AND OPERATING PRECAUTIONS FOR TIIS FLAMEPROOF EQUIPMENT” at the end of this manual.
- Only trained persons use this instrument in the industrial location.
- The protective grounding (⊕) must be connected to a suitable IS grounding system.
- Take care not to generate mechanical spark when access to the instrument and peripheral devices in hazardous locations.

(6) European Pressure Equipment Directive (PED)

**WARNING**

- When using the instrument in compliance with PED, be sure to read Chapter 7 before use.

(7) Modification

Yokogawa will not be liable for malfunctions or damage resulting from any modification made to this instrument by the customer.

(8) Product Disposal

The instrument should be disposed of in accordance with local and national legislation/regulations.

1.2 Warranty

- The terms of this instrument that are guaranteed are described in the quotation. We will make any repairs that may become necessary during the guaranteed term free of charge.
- Please contact our sales office if this instrument requires repair.
- If the instrument is faulty, contact us with concrete details about the problem and the length of time it has been faulty, and state the model and serial number. We would appreciate the inclusion of drawings or additional information.
- The results of our examination will determine whether the meter will be repaired free of charge or on an at-cost basis.

■ The guarantee will not apply in the following cases:

- Damage due to negligence or insufficient maintenance on the part of the customer.
- Problems or damage resulting from handling, operation or storage that violates the intended use and specifications.
- Problems that result from using or performing maintenance on the instrument in a location that does not comply with the installation location specified by Yokogawa.
- Problems or damage resulting from repairs or modifications not performed by Yokogawa or someone authorized by Yokogawa.
- Problems or damage resulting from inappropriate reinstallation after delivery.
- Problems or damage resulting from disasters such as fires, earthquakes, storms, floods, or lightning strikes and external causes.

■ Trademarks:

- All the brands or names of Yokogawa Electric's products used in this manual are either trademarks or registered trademarks of Yokogawa Electric Corporation.
- All other company and product names mentioned in this manual are trade names, trademarks or registered trademarks of their respective companies.
- In this manual, trademarks or registered trademarks are not marked with TM or ®.

1.3 Combination Remote Converters



IMPORTANT

-
- According to suffix codes, AXF remote flowtube should be combined with one of the following remote converters.
 - AXFA11G remote converter
 - AXFA14G remote converter
 - AXFA14C remote converter
 Contact Yokogawa before using it in combination with flowtubes other than those listed above.
 - For ATEX, IECEx or TIIS certified AXF remote flowtube, it is only approved to be combined with AXFA14 converter.
 - If the converter combined with AXF magnetic flowmeter's remote flowtube is changed from AXFA11 to AXFA14 or vice versa, the meter factor of the remote flowtube must be readjusted according to its flow calibration.
-

2. HANDLING PRECAUTIONS

This instrument has been inspected carefully at the factory before shipment. When the instrument is delivered, visually check that no damage has occurred during transportation and check that mounting parts are attached.

Read this section carefully as it contains important information on handling this instrument. Refer to the relevant sections for information not contained in this section. If you have any problems or questions, please contact Yokogawa sales office.

2.1 Checking Model and Specifications

The model code and specifications are found on the name plate located on the outside of the case. Check that the model code and specifications match what you have ordered.

Be sure you have your model number and serial number available when contacting Yokogawa.

ADMAG AXF		MAGNETIC FLOWMETER	METER FACTOR	L	
MODEL SUFFIX			FLUID PRESS.		MPa MAX.
			FLUID TEMP.		°C
			AMB. TEMP.		°C
			TAG NO.		
			NO.		
STYLE SIZE		mm	COMB. NO.		
YOKOGAWA ♦ Made in _____					

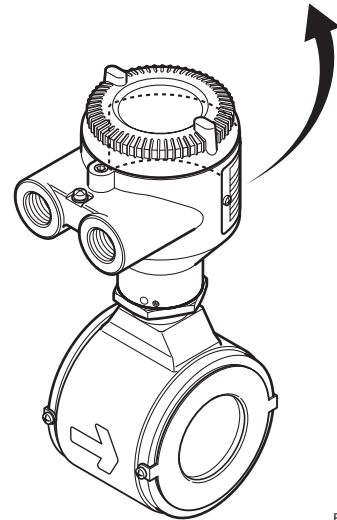

F0202.EPS

Figure 2.1.2 Name Plate (Remote Flowtube)

ADMAG AXF		MAGNETIC FLOWMETER	STYLE SIZE		mm	SUPPLY	VDC $\overline{\overline{12W}}$
MODEL SUFFIX			METER FACTOR	L		VAC- 50/60Hz 30VA 12W	
				H		OUTPUT	mA (0-7500)
			FLUID PRESS.		MPa MAX.		VDC 0.2A MAX.
			FLUID TEMP.		°C	TAG NO.	
			AMB. TEMP.		°C	NO.	
YOKOGAWA ♦ Made in _____							

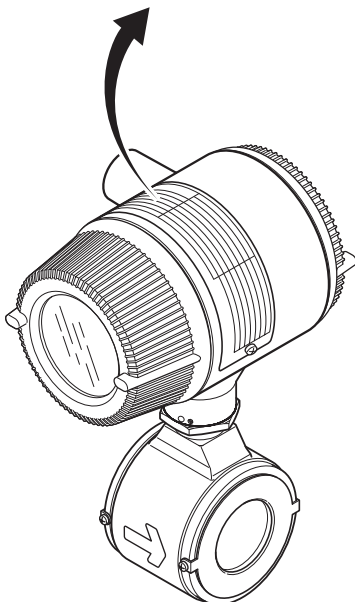

F0201.EPS

Figure 2.1.1 Name Plate (Integral Flowmeter)

2.2 Accessories

Check that the parts shown below are included in the package:

- Centering device (wafer type only): 1 pc.
- Hexagonal wrench: 2 pcs. (one each of 1.5 mm and 3 mm nominal sizes)

2.3 Storage Precautions

If the instrument is to be stored for a long period of time after delivery, observe the following points.

- The instrument should be stored in its original packing condition in the storage location.
- Select a storage location that fulfils the following conditions:
 - A place where it will not be exposed to rain or water
 - A place subject to minimal vibrations or shocks
 - Temperature and humidity levels should be as follows:
 - Temperature: -30 to 70°C
 - Humidity: 5 to 80% RH (no condensation)
 - The preferred ambient temperature and humidity levels are 25°C and approximately 65% RH.
- If the AXF magnetic flowmeter is transferred to the installation site and stored without being installed, its performance may be impaired due to the infiltration of rainwater and so forth. Be sure to install and wire the AXF magnetic flowmeter as soon as possible after transferring it to the installation location.

2.4 Installation Location Precautions

Select the installation location with consideration to the following items to ensure long-term stable operation of the instrument.

- **Ambient Temperature:**
Avoid installing the instrument in locations with constantly fluctuating temperatures. If the location is subject to radiant heat from the plant, provide heat insulation or improve ventilation.
- **Atmospheric Condition:**
Avoid installing the instrument in a corrosive atmosphere. In situations where this is unavoidable, consider ways to improve ventilation and to prevent rainwater from entering and being retained in the conduit pipes.
- **Vibrations or Shocks:**
Avoid installing the instrument in a place subject to shocks or vibrations.

- **Explosion protected type:**

Explosion protect types can be installed in hazardous areas according to the types of gases for which they are certified. See the description in Chapter 8 and “INSTALLATION AND OPERATING PRECAUTIONS FOR TIIS FLAMEPROOF EQUIPMENT” in this user's manual.

3. INSTALLATION

3.1 Piping Design Precautions



WARNING

Installation of the magnetic flowmeter must be performed by expert engineer or skilled personnel. No operator shall be permitted to perform procedures relating to installation.



IMPORTANT

Design piping correctly, referring to the following to prevent damage to flowtube and to assure accurate measuring.



NOTE

This chapter describes the remote flowtube as an example. The same attention must be paid to the integral flowmeter.

(1) Location



IMPORTANT

Install the flowmeter in a location where it is not exposed to direct sunlight. The minimum ambient temperature is limited by the minimum fluid temperature of the flowtube (the lining). For more information, refer to Chapter 6. The flowmeter may be used in an ambient humidity where the relative humidity ranges from 0 to 100%. However, avoid long-term continuous operation at relative humidity above 95%.

(2) Noise Avoidance



IMPORTANT

The flowmeter should be installed away from electrical motors, transformers, and other power sources in order to avoid interference with measurement.

(3) Required Lengths of Straight Runs

To maintain accurate measurement, see JIS B 7554 which explains the requirements for upstream piping conditions of magnetic flowmeters.

Based on JIS B 7554 and our piping condition test data, we recommend the piping conditions as shown in the following figures.

When installing two or more magnetic flowmeters on a single pipe, provide a run of at least 10D between them.

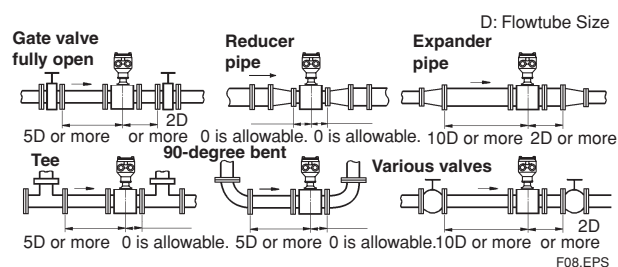

Figure 3.1.1 Required Lengths of Straight Runs

- *1: Do not install anything in the vicinity that may interfere with the magnetic field, induced signal voltages, or flow velocity distributions of the flowmeter.
- *2: A straight run may not be required on the downstream side of the flowmeter. However, if a downstream valve or other fitting causes irregularity or deviation in flows, provide a straight run of 2D to 3D on the downstream side.
- *3: The valves shall be mounted on the downstream side so that deviated flows do not occur in the flowtube and to avoid startup from an empty condition.

(4) Maintaining Stable Fluid Conductivity



IMPORTANT

Do not install the flowmeter where fluid conductivity tends to become uneven. If chemicals are fed near the upstream side of a magnetic flowmeter, they may affect the flow rate's indications. To avoid this situation, it is recommended that the chemical feed ports be located on the downstream side of the flowmeter. If it is unavoidable that chemicals must be fed on the upstream side, provide a sufficient length of straight run (approximately 50D) to ensure the proper mixture of fluids.

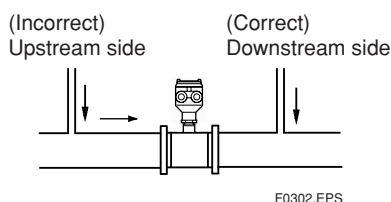

F0302.EPS

Figure 3.1.2 Chemical Injection

(5) Precautions for Use of Liquid Sealing Compounds



IMPORTANT

Care must be taken in using liquid sealing compounds on the piping, as it may have a negative influence on the flow indications by flowing out and covering the surfaces of an electrode or grounding ring. In particular, care must be taken if a liquid sealing compound is used in the case of vertical piping.

(6) Service Area

Select locations where there is adequate space to service installing, wiring, overhauling, etc.

(7) Bypass Line

It is recommended to install a bypass line to facilitate maintenance and zero adjustment.

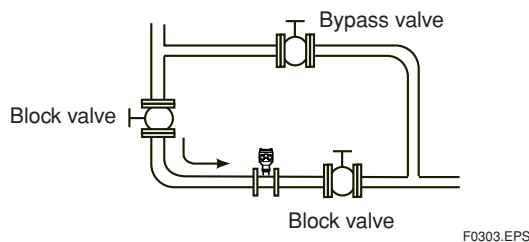

F0303.EPS

Figure 3.1.3 Bypass Line

(8) Supporting the Flowmeter



CAUTION

Do not secure the flowmeter separately to prevent the vibrations, shocks, and expansion and contraction forces of the piping from affecting it. Fix the pipes first, then support the flowmeter with the pipes. With extra small-sized flowmeters (size 2.5 to 10 mm (0.1 to 1.0 in.)), in particular, fix the flowmeter in parallel with the piping on a mounting base.

(9) Mounting Positions

- Pipes must be fully filled with liquids.



IMPORTANT

It is essential that pipes remain fully filled at all times, otherwise flow rate indications may be affected and measurement errors may be caused.

Piping shall be designed so as to maintain the interior of the flowtube filled with fluids.

Vertical mounting is effective in such cases as when fluids tend to separate or solid matter may be precipitated. When employing vertical mounting, direct the fluids from the bottom to the top to ensure that the pipes remain fully filled.

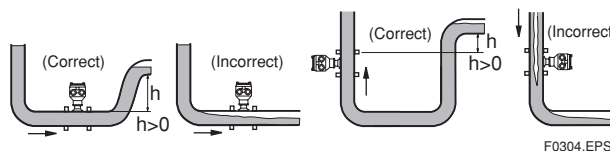

F0304.EPS

Figure 3.1.4 Mounting Positions

- Avoid air bubbles.



IMPORTANT

If air bubbles enter a measurement pipe, flow rate indications may be affected and measurement errors may be caused.

In cases where fluids contain air bubbles, piping must be designed to prevent them from accumulating in the measurement pipe of a flowtube.

If a valve exists near the flowmeter, try to mount the flowmeter on the valve's upstream side in order to prevent a possible reduction of pressure inside the pipe, thereby avoiding the possibility of air bubbles.

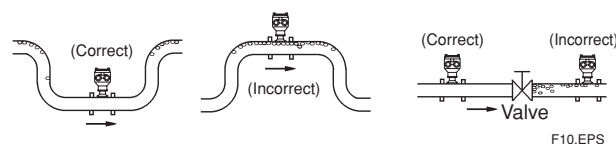

F10.EPS

Figure 3.1.5 Avoiding Air Bubbles

- Mounting orientation

IMPORTANT

If electrodes are perpendicular to the ground, air bubbles near the top or precipitates at the bottom may cause measurement errors. Ensure that the terminal box of a remote flowtube and converter of an integral flowmeter are mounted above the piping to prevent water from entering them.

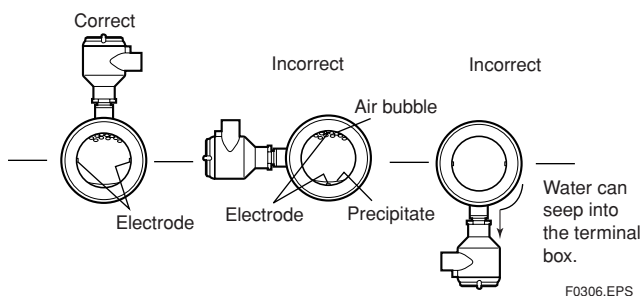

Figure 3.1.6 Mounting Orientation

3.2 Handling Precautions

WARNING

The magnetic flowmeter is a heavy instrument. Be careful that no damage is caused to personnel through accidentally dropping it, or by exerting excessive force on the magnetic flowmeter. When moving the magnetic flowmeter, always use a trolley and have at least two people carry it.

NOTE

This chapter describes the remote flowtube as an example. The same attention must be paid to the integral flowmeter.

3.2.1 General Precautions

(1) Precaution during Transportation

The magnetic flowmeter is packed tightly. When it is unpacked, pay attention to prevent damaging the flowmeter. To prevent accidents while it is being transported to the installing location, transport it to the site in its original packing.

CAUTION

In order to lift a magnetic flowmeter that is fitted with eyebolts, proceed as in Figure 3.2.1. Never lift it using a bar passed through the flowtube as this damages the liner severely.

When lifting the magnetic flowmeter in vertical position, eyebolts (or eye nuts and bolts) are necessary. Attach them to the flange bolt holes, and then lift the magnetic flowmeter.

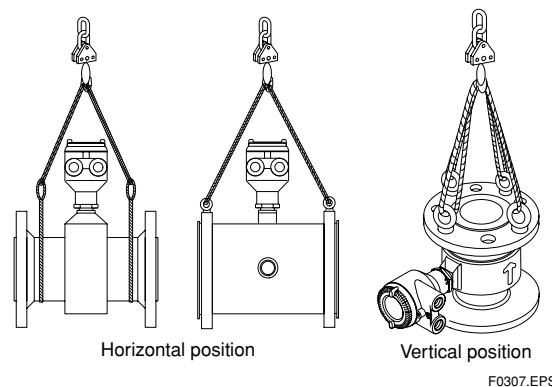

Figure 3.2.1 Lifting Flowmeter

(2) Avoid Shocks from Impact

CAUTION

Care should be taken not to drop the flowmeter or expose it to excessive shock. In particular, be careful not to subject the flange surface to shock. This may lead to liner damage which will result in inaccurate readings.

(3) Flange Protection Covers

IMPORTANT

Keep the protective covering (i.e. the corrugated cardboard or other cushioning material) in place over the flange except when mounting the flowmeter to the pipe.

(4) Terminal Box Cover**IMPORTANT**

As it is possible that the insulation will deteriorate, do not open the terminal box cover until it is time to wire it.

(5) Long-term Non-use**IMPORTANT**

It is not desirable to leave the flowmeter unused for a long term after installation. If this situation is unavoidable, take care of the flowmeter by observing the following.

- **Confirmation of sealing conditions for the flowmeter**

Confirm that the terminal box screw and wiring ports are well sealed. Equip the conduit piping with drain plugs or waterproof glands to prevent moisture or water from penetrating into the flowmeter through the conduit.

- **Regular inspections**

Inspect the sealing conditions as mentioned above, and the inside of the terminal box at least once a year. Also, due to rain, etc. when it is suspected that water may have penetrated into the inside flowmeter perform supplementary inspections.

3.2.2 Flowmeter Piping**CAUTION**

Misaligned or slanted piping can lead to leakage and damage to the flanges.

- (1) Correct any misaligned or slanted piping, and any gaps that may exist between mounting flanges before installing the flowmeter (refer to Figure 3.2.2).

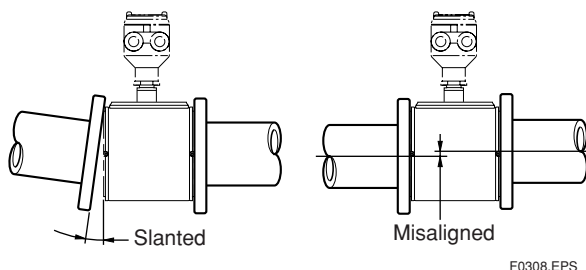

Figure 3.2.2 Slanted and Misaligned Flowmeter Piping

- (2) Inside a newly installed pipeline, there may be some foreign substances such as residue from welding or wood chips. Remove them by flushing the piping before mounting the flowmeter. This prevents the lining from being damaged, as well as the occurrence of erroneous measured signals resulting from foreign substances passing through the flowtube during measurement.

3.3 Mounting Procedures**IMPORTANT**

Do not forget to insert gaskets from Yokogawa between pipes and flowmeter, which shall be supplied when the flowmeter has ceramics lining with no grounding rings.

In case of grounding rings to be supplied and attached later, these gaskets shall be inserted between grounding rings and flowmeter.

**NOTE**

- The tightening torque value to which gaskets must be tightened varies depending on the type and external dimensions of the lining and the gasket. In this section, the tables indicating tightening torque values include the corresponding gasket types. The internal diameters of the gaskets are close to those of the grounding rings.
- For fluids capable of potentially permeating PFA linings (such as nitric acid, hydrofluoric acid, or sodium hydrate at high temperatures), different tightening torque values must be applied. The tables of these torque values is indicated in this section.
- For replacement models for the earlier ADMAG or ADMAG AE, the tightening torque values in the tables can be applied if their process connections, the lining types, and the nominal sizes are the same.

3.3.1 Nominal Diameter 2.5 mm (0.1 in.) to 10 mm (0.4 in.), Union Joint Type

Ceramics linings with diameters of 2.5, 5 or 10 mm (0.1, 0.2 or 0.4 in.) are connected using union joints. Weld or screw the connecting fittings in Table 3.3.1 onto the piping. The external dimensions of the fittings are shown in the Table 3.3.1.

Table 3.3.1 Fitting Dimensions

Screw joint (process connection codes: GUR and GUN)

Unit: mm (inch)

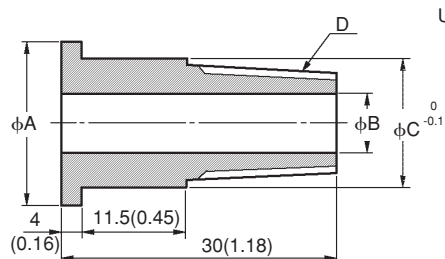

Size	Code	φA	φB	φC	D
2.5 (0.1)	GUR	22 (0.87)	8 (0.31)	18.5 (0.73)	R1/4
	GUN	22 (0.87)	8 (0.31)	18.5 (0.73)	NPT1/4
5 (0.2)	GUR	22 (0.87)	8 (0.31)	18.5 (0.73)	R1/4
	GUN	22 (0.87)	8 (0.31)	18.5 (0.73)	NPT1/4
10 (0.4)	GUR	25 (0.98)	10 (0.39)	22.5 (0.89)	R3/8
	GUN	25 (0.98)	10 (0.39)	22.5 (0.89)	NPT3/8

T0301.EPS

Weld joint (process connection code: GUW)

Unit: mm (inch)

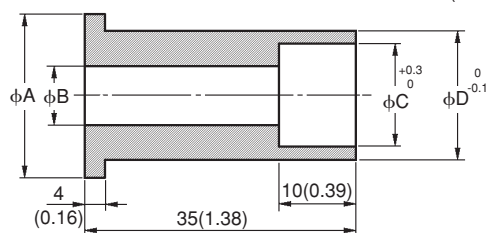

Size	Code	φA	φB	φC	φD
2.5 (0.1)	GUW	22(0.87)	8(0.31)	14.3(0.56)	18.5(0.73)
5 (0.2)	GUW	22(0.87)	8(0.31)	14.3(0.56)	18.5(0.73)
10 (0.4)	GUW	25(0.98)	10(0.39)	17.8(0.70)	22.5(0.89)

T0302.EPS

(1) Mounting Direction

Mount the flowmeter so that the flow direction of the fluid to be measured is in line with the direction of the arrow mark on the flowmeter.

**IMPORTANT**

If it is impossible to match the direction of the arrow mark, the direction of the electrical connection can be changed. Refer to Section 5.1 to do this properly.

In case the fluid being measured flows against the arrow direction, refer to the parameter **J20: Flow Direction** in the user's manual of the AXFA11 Magnetic Flowmeter Remote Converter (IM 01E20C01-01E) or the AXFA14 Magnetic Flowmeter Remote Converter/AXF Integral Flowmeter [Software Edition] (IM 01E20C02-01E).

(2) Connecting Process Piping

Weld or screw the connection fittings to the process piping.

**IMPORTANT**

- Be sure to pass the connection fittings through the union joint nuts in advance.
- When welding the fittings, pay attention to the edge preparation, level differences between the fittings and the piping, and the welding current to avoid deforming the piping or causing stagnation portion of the fluid.

(3) Positioning the Flowmeter

Install the flowmeter on a mounting base and position it so that the center axis of the flowtube is aligned with that of the process piping. Then screw the union joint nuts to the connecting ports of the flowmeter.

**CAUTION**

Ceramics pipes may be damaged if the nuts are tightened when the center axes are not properly aligned.

(4) Tightening Nuts

Use a torque wrench to tighten the union joint nuts.

**CAUTION**

Tighten the nuts according to the torque values in Table 3.3.2 when the gaskets are Valqua #7020 (standard) or alkali-resistant gaskets for the metal piping (optional code GF). For permeable fluid (such as nitric acid, hydrofluoric acid or sodium hydrate at high temperature), tighten the nuts according to the torque values in Table 3.3.3.

As the gasket material is fluorocarbon PTFE, it is possible that the nuts may loosen as time passes. Retighten the nuts if this is the case. Be sure to use the gasket (thickness is 1.5 mm) which comes with the flowmeter.

3.3.2 Nominal Diameter 2.5 mm (0.1 in.) to 40 mm (1.5 in.), Wafer Type

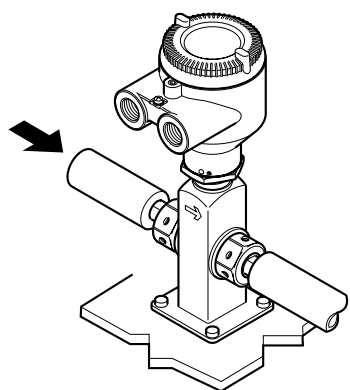
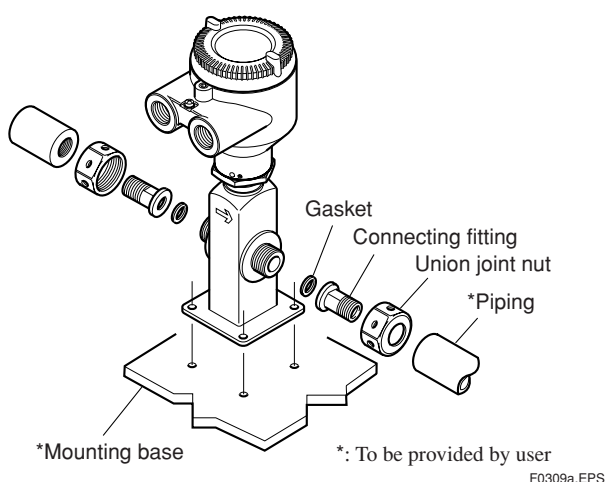

Horizontal mounting

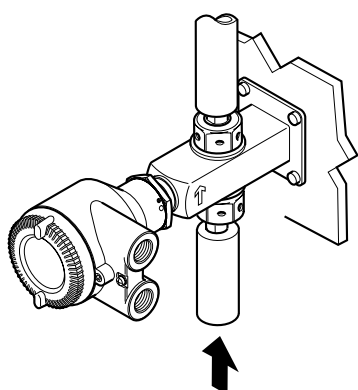

Vertical mounting

Figure 3.3.1 Mounting Procedure for Union Joint Type (size: 2.5 mm (0.1 in.) to 10 mm (0.4 in.))

Table 3.3.2 Tightening torque values for Union Joint Type

Size mm (inch)	Torque (N-m / {kgf-cm} / [in-lbf])
2.5 (0.1)	9 to 12 / {91.77 to 122.4} / [79.66 to 106.2]
5 (0.2)	9 to 12 / {91.77 to 122.4} / [79.66 to 106.2]
10 (0.4)	14 to 18 / {142.8 to 183.5} / [123.9 to 159.3]

T0303.EPS

Table 3.3.3 Tightening torque values for Union Joint Type and Permeable Fluids

Size mm (inch)	Torque (N-m / {kgf-cm} / [in-lbf])
2.5 (0.1)	11 to 15 / {112.2 to 153} / [97.36 to 132.8]
5 (0.2)	11 to 15 / {112.2 to 153} / [97.36 to 132.8]
10 (0.4)	17 to 23 / {173.4 to 234.5} / [150.5 to 203.6]

T0304.EPS

IMPORTANT

Use bolts and nuts in compliance with the flange ratings. When stud-type through-bolts are used, be sure the outside diameter of the shank is smaller than that of the thread ridge. Be sure to choose a gasket with inner and outer diameters that does not protrude inside the piping (refer to Table 3.3.16). If the inner diameter of the gasket is too large, or outer diameter of the gasket is too small, fluid leakage may result.

(1) Mounting Direction

Mount the flowmeter so that the flow direction of the fluid to be measured is in line with the direction of the arrow mark on the flowmeter.

IMPORTANT

If it is impossible to match the direction of the arrow mark, the direction of the electrical connection can be changed. Refer to Section 5.1 to do this properly.

In case the fluid being measured flows against the arrow direction, refer to the parameter **J20: Flow Direction** in the user's manual of the AXFA11 Magnetic Flowmeter Remote Converter (IM 01E20C01-01E) or the AXFA14 Magnetic Flowmeter Remote Converter/AXF Integral Flowmeter [Software Edition] (IM 01E20C02-01E).

(2) Mounting Centering Devices

To maintain concentricity of the flowmeter with the pipes, install centering devices on the Mini-flanges of the flowmeter. Use the appropriate centering devices according to the nominal diameter and the flange ratings.

(3) Positioning the Flowmeter

Pass two through-bolts through the adjacent holes of both flanges and position the flowmeter so that the Mini-flanges and the centering devices come in close contact with each other. Pass the other through-bolts through the other holes (refer to Figure 3.3.2 and Figure 3.3.3). In case stud-type through-bolts are used, position them in such a way that the centering devices come in contact with the bolt threads.

(4) Tightening Nuts

Tighten the nuts according to the torque values for metal piping in Table 3.3.4. For PVC piping, select an optional code of GA, GC, or GD, use rubber gaskets and tighten the nuts to the torque values for PVC piping in Table 3.3.5.

For permeable fluids (such as nitric acid, hydrofluoric acid, or sodium hydrate at high temperatures), tighten the nuts according to the torque values in Table 3.3.6.

CAUTION

For a flowmeter with fluorocarbon PFA lining, it is possible that the nuts may loosen as time passes, so tighten them regularly. Be sure to tighten the nuts according to the prescribed torque values. Tighten them diagonally with the same torque values, step by step up to the prescribed torque value.

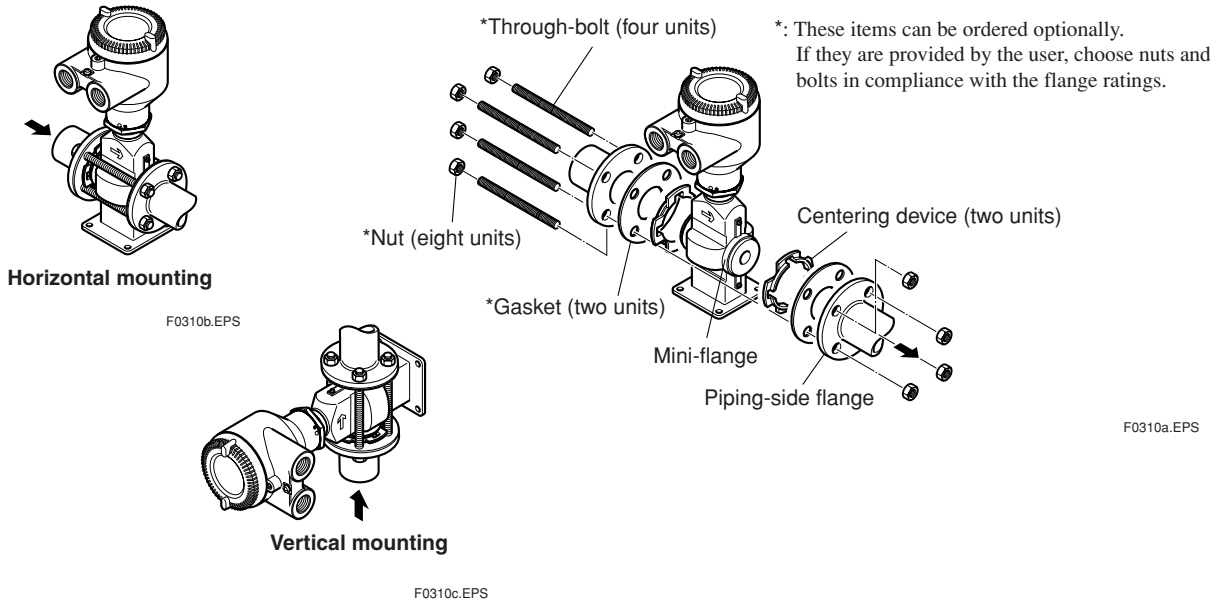

Figure 3.2 Mounting Procedure for Wafer Type (size: 2.5 mm (0.1 in.) to 15 mm (0.5 in.))

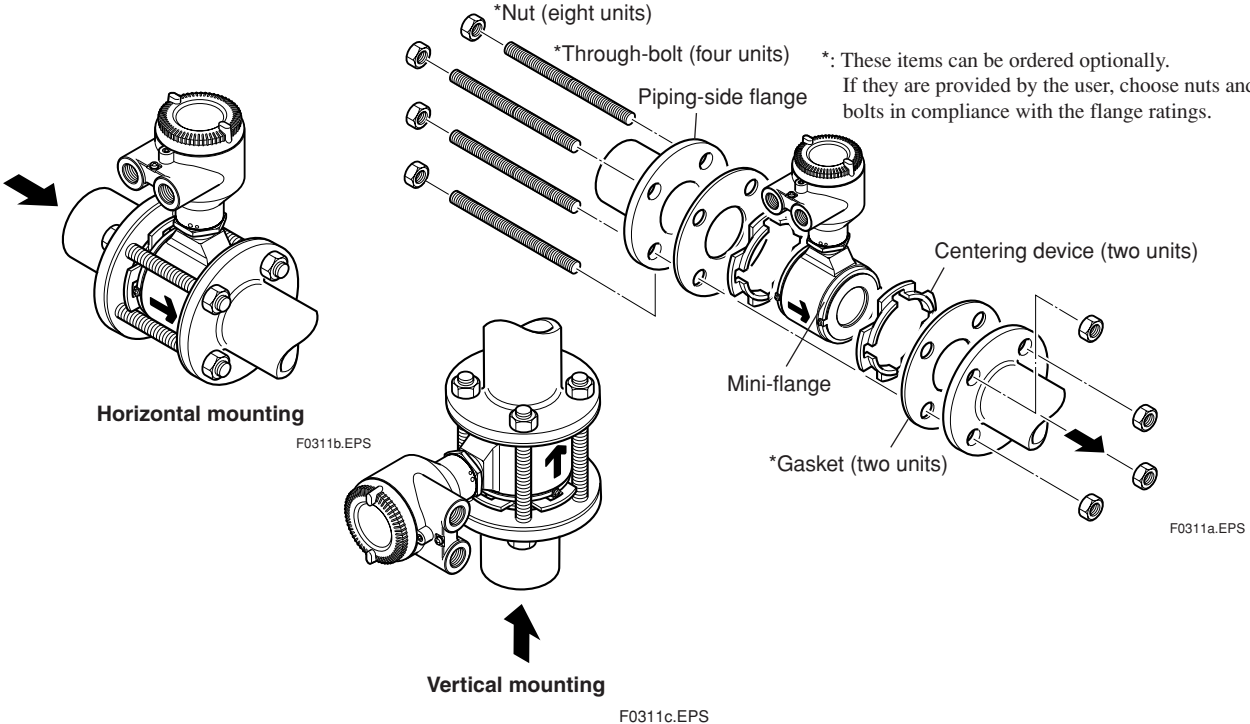

Figure 3.3 Mounting Procedure for Wafer Type (size: 25 mm (1.0 in.), 32 mm (1.25 in.), and 40 mm (1.5 in.))

Table 3.3.4 Wafer Type Tightening Torque Values for Metal Piping

Tightening torque values for PFA/Polyurethane Rubber lining type (N-m / {kgf-cm} / [in-lbf])				
Gasket types within flowtube	No gasket (standard)			
Gasket types for user's flange	Non-asbestos fiber gasket, PTFE-sheathed non-asbestos gasket (optional codes BCF and BSF), or the equivalent in hardness			
Flange ratings Size mm (inch)	JIS 10K ANSI Class 150 DIN PN10	JIS 20K ANSI Class 300 DIN PN16	DIN PN40	JPI Class 150
2.5 (0.1)	7.2 to 8.4 {73.42 to 85.66} [63.72 to 74.35]	7.3 to 8.4 {74.44 to 85.66} [64.61 to 74.35]	7.6 to 8.4 {77.5 to 85.66} [67.26 to 74.35]	7.9 to 12.7 {80.8 to 129.9} [70.1 to 112.7]
5 (0.2)	7.2 to 8.4 {73.42 to 85.66} [63.72 to 74.35]	7.3 to 8.4 {74.44 to 85.66} [64.61 to 74.35]	7.6 to 8.4 {77.5 to 85.66} [67.26 to 74.35]	7.9 to 12.7 {80.8 to 129.9} [70.1 to 112.7]
10 (0.4)	7.2 to 8.4 {73.42 to 85.66} [63.72 to 74.35]	7.3 to 8.4 {74.44 to 85.66} [64.61 to 74.35]	7.6 to 8.4 {77.5 to 85.66} [67.26 to 74.35]	7.9 to 12.7 {80.8 to 129.9} [70.1 to 112.7]
15 (0.5)	7.2 to 8.4 {73.42 to 85.66} [63.72 to 74.35]	7.3 to 8.4 {74.44 to 85.66} [64.61 to 74.35]	7.6 to 8.4 {77.5 to 85.66} [67.26 to 74.35]	7.9 to 12.7 {80.8 to 129.9} [70.1 to 112.7]
25 (1.0)	23.5 to 27.3 {239.6 to 278.4} [208 to 241.6]	23.7 to 27.3 {241.7 to 278.4} [209.8 to 241.6]	22.3 to 27.3 {227.4 to 278.4} [197.4 to 241.6]	19.6 to 21.8 {200.0 to 222.1} [173.5 to 192.6]
32 (1.25)	26.2 to 30.5 {267.2 to 311} [231.9 to 269.9]	26.6 to 30.5 {271.2 to 311} [235.4 to 269.9]	28.0 to 30.5 {285.5 to 311} [247.8 to 269.9]	—
40 (1.5)	36.2 to 42.4 {369.1 to 432.4} [320.4 to 375.3]	36.9 to 42.4 {376.3 to 432.4} [326.6 to 375.3]	39.1 to 42.4 {398.7 to 432.4} [346.1 to 375.3]	30.1 to 33.4 {307.2 to 341.3} [266.5 to 296.0]

Tightening torque values for Ceramics lining type (N-m / {kgf-cm} / [in-lbf])			
Gasket types within flowtube	Fluororesin with ceramic fillers (Valqua #7020) (standard) gasket, or fluororesin with carbon gasket (optional code GF)		
Gasket types for user's flange	Non-asbestos gasket, PTFE-sheathed non-asbestos gasket (optional codes BCF and BSF), or the equivalent in hardness		
Flange ratings Size mm (inch)	JIS 10K ANSI Class 150 DIN PN10	JIS 20K ANSI Class 300 DIN PN16	DIN PN40
15 (0.5)	6.8 to 11.0 / {69.3 to 112.2} / [60.2 to 97.4]	6.8 to 11.0 / {69.3 to 112.2} / [60.2 to 97.4]	6.6 to 11.0 / {67.3 to 112.2} / [58.4 to 97.4]
25 (1.0)	18.9 to 24.5 / {192.7 to 249.8} / [167.3 to 216.8]	19.1 to 24.5 / {194.8 to 249.8} / [169.0 to 216.8]	14.7 to 24.5 / {149.9 to 249.8} / [130.1 to 216.8]
40 (1.5)	34.5 to 45.7 / {351.8 to 466.0} / [305.4 to 404.5]	41.7 to 57.4 / {425.2 to 585.3} / [369.1 to 508.0]	34.5 to 57.4 / {351.8 to 585.3} / [305.4 to 508.0]

T0305.EPS

Table 3.3.5 Wafer Type Tightening Torque Values for PVC Piping

Tightening torque values for PFA lining type (N-m / {kgf-cm} / [in-lbf])				
Gasket types within flowtube	Fluororubber gasket (optional codes GA, GC, and GD)			
Gasket types for user's flange	Fluororubber gasket, chloroprene rubber gasket (optional codes BSC and BCC), or the equivalent in hardness			
Flange ratings Size mm (inch)	JIS 10K ANSI Class 150 DIN PN10	JIS 20K ANSI Class 300 DIN PN16	DIN PN40	JPI Class 150
2.5 (0.1)	1.5 to 2.5 {15.3 to 25.49} [13.28 to 22.13]	1.5 to 2.5 {15.3 to 25.49} [13.28 to 22.13]	1.5 to 2.4 {15.3 to 24.47} [13.28 to 21.24]	1.6 to 2.6 {16.4 to 26.5} [14.2 to 23.0]
5 (0.2)	1.5 to 2.5 {15.3 to 25.49} [13.28 to 22.13]	1.5 to 2.5 {15.3 to 25.49} [13.28 to 22.13]	1.5 to 2.4 {15.3 to 24.47} [13.28 to 21.24]	1.6 to 2.6 {16.4 to 26.5} [14.2 to 23.0]
10 (0.4)	1.5 to 2.5 {15.3 to 25.49} [13.28 to 22.13]	1.5 to 2.5 {15.3 to 25.49} [13.28 to 22.13]	1.5 to 2.4 {15.3 to 24.47} [13.28 to 21.24]	1.6 to 2.6 {16.4 to 26.5} [14.2 to 23.0]
15 (0.5)	1.5 to 2.5 {15.3 to 25.49} [13.28 to 22.13]	1.5 to 2.5 {15.3 to 25.49} [13.28 to 22.13]	1.5 to 2.4 {15.3 to 24.47} [13.28 to 21.24]	1.6 to 2.6 {16.4 to 26.5} [14.2 to 23.0]
25 (1.0)	4.9 to 8.1 {49.97 to 82.6} [43.37 to 71.69]	5.0 to 8.3 {50.99 to 84.64 } [44.25 to 73.46]	4.3 to 7.2 {43.85 to 73.42} [38.06 to 63.72]	4.0 to 6.6 {41.3 to 67.0} [35.8 to 58.1]
32 (1.25)	5.5 to 9.2 {56.08 to 93.81} [48.68 to 81.43]	5.7 to 9.5 {58.12 to 96.87} [50.45 to 84.08]	5.4 to 8.9 {55.06 to 90.75} [47.79 to 78.77]	—
40 (1.5)	7.7 to 12.9 {78.52 to 131.5} [68.15 to 114.2]	8.1 to 13.4 {82.6 to 136.6} [71.69 to 118.6]	7.5 to 12.5 {76.48 to 127.5} [66.38 to 110.6]	6.4 to 10.4 {65.4 to 106.6} [56.7 to 92.4]

Tightening torque values for Ceramics lining type (N-m / {kgf-cm} / [in-lbf])			
Gasket types within flowtube	Fluororubber gasket (optional codes GA, GC, and GD)		
Gasket types for user's flange	Fluororubber gasket, chloroprene rubber gasket (optional codes BSC and BCC), or the equivalent in hardness		
Flange ratings Size mm (inch)	JIS 10K ANSI Class 150 DIN PN10	JIS 20K ANSI Class 300 DIN PN16	DIN PN40
15 (0.5)	0.8 to 1.4 / {8.2 to 14.3} / [7.1 to 12.4]	0.8 to 1.4 / {8.2 to 14.3} / [7.1 to 12.4]	0.8 to 1.4 / {8.2 to 14.3} / [7.1 to 12.4]
25 (1.0)	2.3 to 3.1 / {23.5 to 31.6} / [20.4 to 27.4]	2.4 to 3.1 / {24.5 to 31.6} / [21.2 to 27.4]	1.9 to 3.1 / {19.4 to 31.6} / [16.8 to 27.4]
40 (1.5)	4.4 to 6.0 / {44.9 to 61.2} / [38.9 to 53.1]	5.2 to 7.3 / {53.0 to 74.4} / [46.0 to 64.6]	4.4 to 7.3 / {44.9 to 74.4} / [38.9 to 64.6]

T0306.EPS

Table 3.3.6 Wafer Type Tightening Torque Values for Metal Piping and Permeable Fluids

Tightening torque values for PFA lining type (N-m / {kgf-cm} / [in-lbf])				
Gasket types within flowtube	No gasket (standard)			
Gasket types for user's flange	PTFE-sheathed non-asbestos gasket (optional codes BCF and BSF), or the equivalent in hardness			
Flange ratings Size mm (inch)	JIS 10K ANSI Class 150 DIN PN10	JIS 20K ANSI Class 300 DIN PN16	DIN PN40	JPI Class 150
2.5 (0.1)	10.8 to 12.4 {110.1 to 126.4} [95.59 to 109.7]	10.8 to 12.4 {110.1 to 126.4} [95.59 to 109.7]	11.1 to 12.4 {113.2 to 126.4} [98.24 to 109.7]	11.8 to 12.1 {120.6 to 123.7} [104.6 to 107.3]
5 (0.2)	10.8 to 12.4 {110.1 to 126.4} [95.59 to 109.7]	10.8 to 12.4 {110.1 to 126.4} [95.59 to 109.7]	11.1 to 12.4 {113.2 to 126.4} [98.24 to 109.7]	11.8 to 12.1 {120.6 to 123.7} [104.6 to 107.3]
10 (0.4)	10.8 to 12.4 {110.1 to 126.4} [95.59 to 109.7]	10.8 to 12.4 {110.1 to 126.4} [95.59 to 109.7]	11.1 to 12.4 {113.2 to 126.4} [98.24 to 109.7]	11.8 to 12.1 {120.6 to 123.7} [104.6 to 107.3]
15 (0.5)	10.8 to 12.4 {110.1 to 126.4} [95.59 to 109.7]	10.8 to 12.4 {110.1 to 126.4} [95.59 to 109.7]	11.1 to 12.4 {113.2 to 126.4} [98.24 to 109.7]	11.8 to 12.1 {120.6 to 123.7} [104.6 to 107.3]
25 (1.0)	34.9 to 40.1 {355.9 to 408.9} [308.9 to 354.9]	35.2 to 40.1 {358.9 to 408.9} [311.5 to 354.9]	32.3 to 37.1 {329.4 to 378.3} [285.9 to 328.4]	29.2 to 29.9 {297.6 to 305.5} [258.1 to 265.0]
32 (1.25)	38.8 to 44.6 {395.6 to 454.8} [343.4 to 394.7]	39.2 to 44.6 {399.7 to 454.8} [346.9 to 394.7]	40.6 to 46.7 {414.0 to 476.2} [359.3 to 413.3]	—
40 (1.5)	53.5 to 61.5 {545.5 to 627.1} [473.5 to 544.3]	54.2 to 61.5 {552.7 to 627.1} [479.7 to 544.3]	56.4 to 61.5 {575.1 to 627.1} [499.2 to 544.3]	44.6 to 45.8 {455.0 to 467.3} [394.7 to 405.3]

Tightening torque values for Ceramics lining type (N-m / {kgf-cm} / [in-lbf])				
Gasket types within flowtube	Fluororesin with ceramic fillers (Valqua #7020) gasket (standard), or fluororesin with carbon gasket (optional code GF)			
Gasket types for user's flange	PTFE-sheathed non-asbestos gasket (optional codes BCF and BSF), or the equivalent in hardness			
Flange ratings Size mm (inch)	JIS 10K ANSI Class 150 DIN PN10	JIS 20K ANSI Class 300 DIN PN16	DIN PN40	
15 (0.5)	8.1 to 13.1 / {82.6 to 133.6} / [71.7 to 115.9]	8.1 to 13.1 / {82.6 to 133.6} / [71.7 to 115.9]	7.9 to 13.1 / {80.6 to 133.6} / [69.9 to 115.9]	
25 (1.0)	22.5 to 29.0 / {229.4 to 295.7} / [199.1 to 256.7]	22.7 to 29.0 / {231.5 to 295.7} / [200.9 to 256.7]	17.4 to 29.0 / {177.4 to 295.7} / [154.0 to 256.7]	
40 (1.5)	40.6 to 53.8 / {414.0 to 548.6} / [359.3 to 476.2]	49.3 to 67.7 / {502.7 to 690.3} / [436.3 to 599.2]	40.6 to 67.7 / {414.0 to 690.3} / [359.3 to 599.2]	

T0307.EPS

3.3.3 Nominal Diameter 50 mm (2.0 in.) to 300 mm (12.0 in.), Wafer Type



IMPORTANT

Use bolts and nuts in compliance with the flange ratings. When stud-type through-bolts are used, be sure the outside diameter of the shank is smaller than that of the thread ridge. Be sure to choose a gasket with inner and outer diameters that does not protrude inside the piping (refer to Table 3.3.16). If the inner diameter of the gasket is too large, or outer diameter of the gasket is too small, fluid leakage may result.

(1) Mounting Direction

Mount the flowmeter so that the flow direction of the fluid to be measured is in line with the direction of the arrow mark on the flowmeter.



IMPORTANT

If it is impossible to match the direction of the arrow mark, the direction of the electrical connection can be changed. Refer to Section 5.1 to do this properly.

In case the fluid being measured flows against the arrow direction, refer to the parameter **J20: Flow Direction** in the user's manual of the AXFA11 Magnetic Flowmeter Remote Converter (IM 01E20C01-01E) or the AXFA14 Magnetic Flowmeter Remote Converter/AXF Integral Flowmeter [Software Edition] (IM 01E20C02-01E).

(2) Mounting Centering Devices

To maintain concentricity of the flowmeter with the pipes, install centering devices. From the process piping side, pass two through-bolts through the four centering devices (two for each bolt) and the adjacent two holes (the lower two holes for horizontal mounting) of both of the flanges (refer to Figure 3.3.4). Use the appropriate centering devices according to the nominal diameter and the flange ratings. The centering devices are engraved with an identifying character. Use the appropriate ones which meet the required specifications by referring to Table 3.3.10 and Table 3.3.11 (AXF standard models) and Table 3.3.12 (replacement models for the earlier ADMAG or ADMAG AE).

(3) Positioning the Flowmeter

Position the flowmeter so that the Mini-flanges and the centering devices come in close contact with each other. Be careful to prevent the four centering devices from coming into contact with the housing. If stud-type through-bolts are used, position them in such a way that the four centering devices come in contact with the bolt threads (refer to Figure 3.3.4). Pass the other through-bolts through from the process piping side.



NOTE

Precautions for size 125 mm (5 in.), 150 mm (6 in.), replaceable electrode type

When installing this type of flowmeter with JIS F12 (JIS 75M) flanges, turn the flowmeter slightly because the cover of the electrode chambers will interfere with the bolts.

(4) Tightening Nuts

Tighten the nuts according to the torque values for metal piping in Table 3.3.7. For PVC piping, select an optional code of GA, GC, or GD, use rubber gaskets and tighten the nuts to the torque values for PVC piping in Table 3.3.8.

For permeable fluids (such as nitric acid, hydrofluoric acid, or sodium hydrate at high temperatures), tighten the nuts according to the torque values in Table 3.3.9.



CAUTION

For a flowmeter with fluorocarbon PFA lining, it is possible that the nuts may loosen as time passes, so tighten them regularly. Be sure to tighten the nuts according to the prescribed torque values. Tighten them diagonally with the same torque values, step by step up to the prescribed torque value.

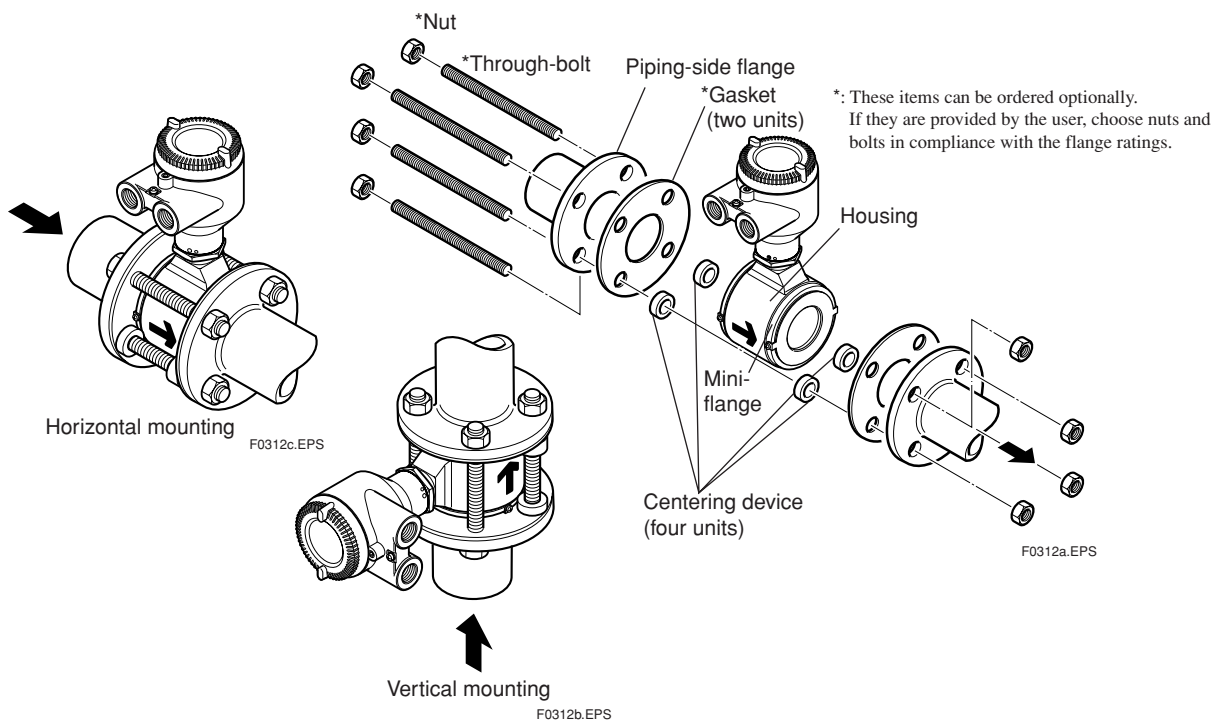

Figure 3.3.4 Mounting Procedure for Wafer Type (size: 50 mm (2 in.) to 300 mm (12 in.))

Table 3.3.7 Wafer Type Tightening Torque Values for Metal Piping

Tightening torque values for PFA/Polyurethane Rubber/Natural Soft Rubber/EPDM Rubber lining type									Unit: $\frac{\text{N}\cdot\text{m}}{(\text{kgf}\cdot\text{cm})}$ $\frac{\text{in}\cdot\text{lbft}}{(\text{in}\cdot\text{lbft})}$
Gasket types within flowtube	No gasket (standard)								
	Non-asbestos fiber gasket, PTFE-sheathed non-asbestos gasket (optional codes BCF and BSF), or the equivalent in hardness								
Gasket types for user's flange	Non-asbestos gasket, PTFE-sheathed non-asbestos gasket (optional codes BCF and BSF), or the equivalent in hardness								
Flange ratings	JIS 10K	ANSI Class 150	DIN PN10	JIS 20K	ANSI Class 300	DIN PN16	DIN PN40	JIS F12 (JIS 75M)	JPI Class 150
Size mm (inch)									
50 (2.0)	45.0 to 56.8 {458.9 to 579.2} {398.3 to 502.7}	45.0 to 56.8 {458.9 to 579.2} {398.3 to 502.7}	—	22.5 to 25.9 {229.4 to 264.1} {199.1 to 229.2}	22.5 to 25.9 {229.4 to 264.1} {199.1 to 229.2}	—	50.0 to 57.5 {509.9 to 586.3} {42.5 to 508.9}	—	44.5 to 50.9 {454.1 to 519.8} {393.9 to 450.9}
65 (2.5)	61.3 to 70.5 {625.1 to 718.9} {542.5 to 624.0}	61.3 to 70.5 {625.1 to 718.9} {542.5 to 624.0}	—	30.8 to 35.4 {314.1 to 361.0} {272.6 to 313.3}	30.8 to 35.4 {314.1 to 361.0} {272.6 to 313.3}	56.1 to 70.8 {572.1 to 722.0} {496.5 to 626.6}	—	—	—
80 (3.0)	35.0 to 40.3 {356.9 to 410.9} {309.8 to 356.7}	35.0 to 40.3 {356.9 to 410.9} {309.8 to 356.7}	—	39.9 to 45.9 {406.9 to 468.1} {353.1 to 406.2}	39.9 to 45.9 {406.9 to 468.1} {353.1 to 406.2}	—	—	68.4 to 78.7 {697.5 to 802.5} {605.4 to 696.5}	70.0 to 80.1 {714.4 to 817.8} {619.6 to 709.3}
100 (4.0)	46.1 to 53 {470.1 to 540.5} {408.0 to 469.1}	46.1 to 53 {470.1 to 540.5} {408.0 to 469.1}	—	52.9 to 60.8 {539.4 to 620.0} {468.2 to 538.1}	52.9 to 60.8 {539.4 to 620.0} {468.2 to 538.1}	—	—	88.6 to 101.9 {903.5 to 1039} {784.1 to 901.9}	45.0 to 51.5 {459.0 to 525.2} {398.1 to 455.6}
125 (5.0)	73.7 to 84.8 {751.5 to 864.7} {652.3 to 750.5}	73.7 to 84.8 {751.5 to 864.7} {652.3 to 750.5}	—	80.5 to 92.6 {820.9 to 944.3} {712.5 to 819.5}	80.5 to 92.6 {820.9 to 944.3} {712.5 to 819.5}	80.5 to 92.6 {820.9 to 944.3} {712.5 to 819.5}	—	75.1 to 86.4 {765.8 to 881.0} {664.7 to 764.7}	—
150 (6.0)	85.4 to 98.2 {870.8 to 1001} {755.8 to 869.1}	85.4 to 98.2 {870.8 to 1001} {755.8 to 869.1}	—	61.0 to 70.2 {622.0 to 715.8} {539.9 to 621.3}	61.0 to 70.2 {622.0 to 715.8} {539.9 to 621.3}	91.2 to 96.3 {930.0 to 982.0} {807.2 to 852.3}	—	86.3 to 99.2 {880.0 to 1012} {763.8 to 878.0}	78.9 to 86.2 {805.2 to 879.9} {698.4 to 763.2}
200 (8.0)	78.8 to 90.6 {803.5 to 923.9} {697.4 to 801.8}	113.6 to 135.8 {1158 to 1385} {1005 to 1202}	113.6 to 135.8 {1158 to 1385} {1005 to 1202}	87.5 to 100.6 {892.3 to 1026} {774.4 to 890.3}	87.5 to 100.6 {892.3 to 1026} {774.4 to 890.3}	87.5 to 100.6 {892.3 to 1026} {774.4 to 890.3}	—	88.6 to 101.9 {903.5 to 1039} {784.1 to 901.9}	109.6 to 119.7 {1118 to 1221} {970 to 1060}
250 (10)	119.4 to 137.3 {1218 to 1400} {1057 to 1215}	119.4 to 137.3 {1218 to 1400} {1057 to 1215}	119.4 to 137.3 {1218 to 1400} {1057 to 1215}	—	—	—	—	158.1 to 181.8 {1612 to 1854} {1399 to 1609}	120.8 to 136.4 {1232 to 1392} {1069 to 1207}
300 (12)	83.0 to 99.2 {846.4 to 1012} {734.6 to 878}	105.2 to 121.0 {1073 to 1234} {931.1 to 1071}	105.2 to 121.0 {1073 to 1234} {931.1 to 1071}	—	—	—	—	146.6 to 168.6 {1495 to 1719} {1297 to 1492}	141.8 to 160.1 {1447 to 1634} {1255 to 1417}

Tightening torque values for Ceramics lining type									Unit: $\frac{\text{N}\cdot\text{m}}{(\text{kgf}\cdot\text{cm})}$ $\frac{\text{in}\cdot\text{lbft}}{(\text{in}\cdot\text{lbft})}$
Gasket types within flowtube	Fluororesin with ceramic fillers (Valqua #7020) gasket (standard), or fluororesin with carbon gasket (optional code GF)								
	Non-asbestos gasket, PTFE-sheathed non-asbestos gasket (optional codes BCF and BSF), or the equivalent in hardness								
Gasket types for user's flange	Non-asbestos gasket, PTFE-sheathed non-asbestos gasket (optional codes BCF and BSF), or the equivalent in hardness								
Flange ratings	JIS 10K	ANSI Class 150	DIN PN10	JIS 20K	ANSI Class 300	DIN PN16	DIN PN40	JIS F12 (JIS 75M)	
Size mm (inch)									
50 (2.0)	48.2 to 80.3 {491.5 to 818.8} {426.6 to 710.7}	48.6 to 81.0 {495.6 to 826.0} {430.1 to 716.9}	—	23.5 to 39.1 {239.6 to 398.7} {208.0 to 346.1}	23.7 to 39.5 {241.7 to 402.8} {209.8 to 349.6}	—	48.2 to 80.3 {491.5 to 818.8} {426.6 to 710.7}	—	—
80 (3.0)	31.5 to 52.4 {321.2 to 534.3} {278.8 to 463.8}	64.2 to 107.0 {654.7 to 1091.1} {568.2 to 947.0}	—	38.8 to 64.7 {395.6 to 659.8} {343.4 to 572.6}	38.2 to 63.7 {389.5 to 649.6} {338.1 to 563.8}	31.5 to 52.4 {321.2 to 534.3} {278.8 to 463.8}	—	63.7 to 106.2 {649.6 to 1082.9} {563.8 to 939.9}	—
100 (4.0)	36.0 to 59.9 {367.1 to 610.8} {318.6 to 530.2}	36.3 to 60.4 {370.2 to 615.9} {321.3 to 534.6}	—	44.3 to 73.8 {451.7 to 752.6} {392.1 to 653.2}	43.6 to 72.7 {444.6 to 741.3} {385.9 to 643.4}	36.0 to 59.9 {367.1 to 610.8} {318.6 to 530.2}	—	73.0 to 121.6 {744.4 to 1240.0} {646.1 to 1076.3}	—
150 (6.0)	75.5 to 125.9 {769.9 to 1283.8} {668.2 to 1114.3}	74.4 to 123.9 {758.7 to 1263.4} {658.5 to 1096.6}	—	53.4 to 89.1 {544.5 to 908.6} {472.6 to 788.6}	48.8 to 81.3 {497.6 to 829.0} {431.9 to 719.6}	75.5 to 125.9 {769.9 to 1283.8} {668.2 to 1114.3}	—	82.3 to 137.1 {839.2 to 1398.0} {728.4 to 1213.4}	—
200 (8.0)	72.9 to 121.6 {743.4 to 1240.0} {645.2 to 1076.3}	109.1 to 181.8 {1112.5 to 1853.8} {965.6 to 1609.1}	110.9 to 184.9 {1130.9 to 1885.5} {981.5 to 1636.5}	79.0 to 131.6 {805.6 to 1341.9} {699.2 to 1164.8}	80.0 to 135.3 {815.8 to 1359.3} {708.1 to 1179.8}	72.9 to 121.6 {743.4 to 1240.0} {645.2 to 1076.3}	—	89.7 to 149.5 {914.7 to 1524.5} {793.9 to 1323.2}	—

T0308.EPS

Table 3.3.8 Wafer Type Tightening Torque Values for PVC Piping

Tightening torque values for PFA lining type										Unit:	N·m (kgf·cm) (in·lbf)
Fluororubber gasket (optional codes GA, GC, and GD)											
Fluororubber gasket, chloroprene rubber gasket (optional codes BSC and BCC), or the equivalent in hardness											
Flange ratings	JIS 10K	ANSI Class 150	DIN PN10	JIS 20K	ANSI Class 300	DIN PN16	DIN PN40	JIS F12 (JIS 75M)	JPI Class 150		
Size mm (inch)											
50 (2.0)	9.9 to 16.5 (101.0 to 168.3) [87.6 to 146.0]	9.9 to 16.5 (101.0 to 168.3) [87.6 to 146.0]	—	10.6 to 17.6 (108.1 to 179.5) [93.8 to 155.8]	10.6 to 17.6 (108.1 to 179.5) [93.8 to 155.8]	—	9.5 to 15.9 (96.9 to 162.1) [84.1 to 140.7]	—	9.6 to 15.9 (98.1 to 162.2) [85.1 to 140.7]		
65 (2.5)	14.2 to 23.7 (144.8 to 241.7) [125.7 to 209.8]	14.2 to 23.7 (144.8 to 241.7) [125.7 to 209.8]	—	15.5 to 25.9 (158.1 to 264.1) [137.2 to 229.2]	15.5 to 25.9 (158.1 to 264.1) [137.2 to 229.2]	28.2 to 51.8 (287.6 to 528.2) [249.6 to 458.4]	—	—	—		
80 (3.0)	8.0 to 13.3 (81.6 to 135.6) [70.8 to 117.7]	8.0 to 13.3 (81.6 to 135.6) [70.8 to 117.7]	—	9.7 to 16.1 (98.9 to 164.2) [85.8 to 142.5]	9.7 to 16.1 (98.9 to 164.2) [85.8 to 142.5]	—	—	15.4 to 25.6 (157.0 to 261.0) [136.3 to 226.6]	16.4 to 27.0 (167.1 to 275.9) [145.0 to 239.3]		
100 (4.0)	11.3 to 18.8 (115.2 to 191.7) [100.0 to 166.4]	11.3 to 18.8 (115.2 to 191.7) [100.0 to 166.4]	—	14.2 to 23.6 (144.8 to 240.7) [125.7 to 208.9]	14.2 to 23.6 (144.8 to 240.7) [125.7 to 208.9]	—	—	14.2 to 23.6 (152.2 to 357.9) [186.7 to 310.6]	10.6 to 17.5 (108.2 to 178.3) [93.8 to 154.7]		
125 (5.0)	18.8 to 31.3 (191.7 to 319.2) [166.4 to 277.0]	18.8 to 31.3 (191.7 to 319.2) [166.4 to 277.0]	—	22.3 to 37.2 (227.4 to 379.3) [197.4 to 329.2]	22.3 to 37.2 (227.4 to 379.3) [197.4 to 329.2]	—	—	18.5 to 30.8 (188.6 to 314.1) [163.7 to 272.6]	—		
150 (6.0)	22.5 to 37.6 (229.4 to 383.4) [199.1 to 332.8]	22.5 to 37.6 (229.4 to 383.4) [199.1 to 332.8]	—	27.2 to 45.3 (277.4 to 461.9) [240.7 to 400.9]	27.2 to 45.3 (277.4 to 461.9) [240.7 to 400.9]	—	—	27.2 to 45.3 (415.0 to 633.2) [360.2 to 549.6]	—	19.9 to 32.0 (202.8 to 326.0) [175.9 to 282.8]	
200 (8.0)	22.1 to 36.9 (225.4 to 376.3) [195.6 to 326.6]	31.9 to 55.3 (325.3 to 563.9) [282.3 to 489.4]	31.9 to 55.3 (325.3 to 563.9) [282.3 to 489.4]	27.3 to 45.3 (278.4 to 461.9) [241.6 to 400.9]	27.3 to 45.3 (278.4 to 461.9) [241.6 to 400.9]	—	—	27.3 to 45.3 (427.2 to 403.8) [210.6 to 350.5]	30.6 to 49.2 (312.3 to 501.7) [270.9 to 435.2]		

Tightening torque values for Ceramics lining type										Unit:	N·m (kgf·cm) (in·lbf)
Fluororubber gasket (optional codes GA, GC, and GD)											
Fluororubber gasket, chloroprene rubber gasket (optional codes BSC and BCC), or the equivalent in hardness											
Flange ratings	JIS 10K	ANSI Class 150	DIN PN10	JIS 20K	ANSI Class 300	DIN PN16	DIN PN40	JIS F12 (JIS 75M)	JPI Class 150		
Size mm (inch)											
50 (2.0)	6.2 to 10.4 (63.2 to 106.1) [54.9 to 92.0]	6.3 to 10.5 (64.2 to 107.1) [55.8 to 92.9]	—	2.9 to 4.9 (29.6 to 50.0) [25.7 to 43.4]	2.9 to 4.9 (29.6 to 50.0) [25.7 to 43.4]	—	6.2 to 10.4 (63.2 to 106.1) [54.9 to 92.0]	—	—		
80 (3.0)	4.4 to 7.3 (44.9 to 74.4) [38.9 to 64.6]	4.4 to 7.3 (44.9 to 74.4) [38.9 to 64.6]	—	5.3 to 8.8 (54.0 to 89.7) [46.9 to 77.9]	5.3 to 8.8 (54.0 to 89.7) [46.9 to 77.9]	—	4.4 to 7.3 (44.9 to 74.4) [38.9 to 64.6]	—	9.6 to 16.0 (97.9 to 163.2) [85.0 to 141.6]		
100 (4.0)	5.2 to 8.6 (53.0 to 87.7) [46.0 to 76.1]	5.7 to 9.5 (58.1 to 96.9) [50.4 to 84.1]	—	6.0 to 10.0 (61.2 to 102.0) [53.1 to 88.5]	6.0 to 10.0 (61.2 to 102.0) [53.1 to 88.5]	—	5.2 to 8.6 (53.0 to 87.7) [46.0 to 76.1]	—	11.7 to 19.5 (119.3 to 198.8) [103.6 to 172.6]		
150 (6.0)	10.7 to 17.8 (109.1 to 181.5) [94.7 to 157.5]	11.6 to 19.3 (118.3 to 196.8) [102.7 to 170.8]	—	7.0 to 11.6 (71.4 to 118.3) [62.0 to 102.7]	6.6 to 11.0 (67.3 to 112.2) [58.4 to 97.4]	—	10.7 to 17.8 (109.1 to 181.5) [94.7 to 157.5]	—	13.3 to 22.2 (135.5 to 226.4) [117.7 to 196.5]		
200 (8.0)	10.2 to 17.1 (104.0 to 174.4) [90.3 to 151.3]	18.9 to 31.5 (192.7 to 321.2) [167.3 to 278.8]	18.7 to 31.2 (190.7 to 318.2) [165.5 to 276.1]	10.6 to 17.7 (108.1 to 180.5) [93.8 to 159.3]	10.8 to 18.0 (110.1 to 183.5) [95.6 to 159.3]	—	10.2 to 17.1 (104.0 to 174.4) [90.3 to 151.3]	—	15.3 to 25.5 (156.0 to 260.0) [135.4 to 225.7]		

T0309.EPS

Table 3.3.9 Wafer Type Tightening Torque Values for Metal Piping and Permeable Fluids

Tightening torque values for PFA lining type										Unit:	N·m (kgf·cm) (in·lbf)	
No gasket (standard)												
PTFE-sheathed non-asbestos gasket (optional codes BCF and BSF), or the equivalent in hardness												
Flange ratings	JIS 10K	ANSI Class 150	DIN PN10	JIS 20K	ANSI Class 300	DIN PN16	DIN PN40	JIS F12 (JIS 75M)	JPI Class 150			
Size mm (inch)												
50 (2.0)	66.2 to 76.1 (673.1 to 776.0) [585.9 to 673.5]	66.2 to 76.1 (673.1 to 776.0) [585.9 to 673.5]	—	33.1 to 38.0 (337.5 to 387.5) [292.9 to 336.3]	33.1 to 38.0 (337.5 to 387.5) [292.9 to 336.3]	—	71.2 to 118.6 (726.0 to 1209) [630.1 to 1050]	—	65.7 to 69.7 (670.9 to 711.0) [581.9 to 616.7]			
65 (2.5)	89.5 to 102.9 (912.6 to 1049) [792.1 to 910.7]	89.5 to 102.9 (912.6 to 1049) [792.1 to 910.7]	—	44.9 to 51.6 (457.9 to 526.2) [397.4 to 456.7]	44.9 to 51.6 (457.9 to 526.2) [397.4 to 456.7]	—	81.8 to 103.2 (834.1 to 1052) [724.0 to 913.4]	—	—			
80 (3.0)	51.3 to 59.0 (523.1 to 601.6) [454.0 to 522.2]	111.3 to 118.4 (1135 to 1207) [985.0 to 1048]	—	58.1 to 66.8 (592.5 to 681.2) [514.2 to 591.2]	58.1 to 66.8 (592.5 to 681.2) [514.2 to 591.2]	—	58.1 to 66.8 (592.5 to 681.2) [514.2 to 591.2]	—	100.8 to 115.9 (1028 to 1182) [892.1 to 1026]	102.5 to 108.7 (1046 to 1109) [907.7 to 962.0]		
100 (4.0)	66.7 to 76.7 (680.2 to 782.1) [590.3 to 678.8]	66.7 to 76.7 (680.2 to 782.1) [590.3 to 678.8]	—	76.1 to 87.5 (776.0 to 892.3) [673.5 to 774.4]	76.1 to 87.5 (776.0 to 892.3) [673.5 to 774.4]	—	76.1 to 87.5 (776.0 to 892.3) [673.5 to 774.4]	—	129.5 to 149.3 (1324 to 1522) [1149 to 1321]	65.7 to 69.6 (670.1 to 710.0) [581.2 to 615.9]		
125 (5.0)	106.1 to 122.0 (1082 to 1244) [939.0 to 1080]	106.1 to 122.0 (1082 to 1244) [939.0 to 1080]	—	114.5 to 131.7 (1168 to 1343) [1013 to 1166]	114.5 to 131.7 (1168 to 1343) [1013 to 1166]	—	114.5 to 131.7 (1168 to 1343) [1013 to 1166]	—	109.6 to 126.0 (1118 to 1285) [970.0 to 1115]	—		
150 (6.0)	122.2 to 140.5 (1246 to 1433) [1082 to 1243]	122.2 to 140.5 (1246 to 1433) [1082 to 1243]	—	86.8 to 99.8 (885.1 to 1018) [768.2 to 883.3]	86.8 to 99.8 (885.1 to 1018) [768.2 to 883.3]	—	86.8 to 99.8 (885.1 to 1018) [768.2 to 883.3]	—	129.5 to 149.3 (1281 to 1472) [1112 to 1278]	114.2 to 115.3 (1165 to 1177) [1010 to 1021]		
200 (8.0)	111.6 to 128.3 (1138 to 1308) [987.7 to 1136]	161.0 to 192.3 (1642 to 1961) [1425 to 1702]	161.0 to 192.3 (1642 to 1961) [1425 to 1702]	122.0 to 140.3 (1244 to 1431) [1080 to 1242]	122.0 to 140.3 (1244 to 1431) [1080 to 1242]	—	122.0 to 140.3 (1244 to 1431) [1080 to 1242]	—	128.0 to 147.2 (1305 to 1501) [1133 to 1303]	156.7 to 158.3 (1599 to 1615) [1387 to 1401]		
250 (10)	167.7 to 192.9 (1710 to 1967) [1484 to 1707]	167.7 to 192.9 (1710 to 1967) [1484 to 1707]	—	—	—	—	—	—	227.6 to 261.7 (2321 to 2669) [2014 to 2316]	172.3 to 175.8 (1758 to 1794) [1525 to 1556]		
300 (12)	115.2 to 137.6 (1175 to 1403) [1020 to 1218]	146.0 to 167.9 (1489 to 1712) [1292 to 1486]	146.0 to 167.9 (1489 to 1712) [1292 to 1486]	—	—	—	—	—	209.1 to 240.5 (2132 to 2452) [1851 to 2129]	199.8 to 203.9 (2039 to 2080) [1768 to 1805]		

Tightening torque values for Ceramics lining type										Unit:	N·m (kgf·cm) (in·lbf)
Fluoro-resin with ceramic fillers (Valqua #7020) gasket (standard), or fluoro-resin with carbon gasket (optional code GF)											
PTFE-sheathed non-asbestos gasket (optional codes BCF and BSF), or the equivalent in hardness											
Flange ratings	JIS 10K	ANSI Class 150	DIN PN10	JIS 20K	ANSI Class 300	DIN PN16	DIN PN40	JIS F12 (JIS 75M)	JPI Class 150		
Size mm (inch)											
50 (2.0)	56.5 to 94.2 (576.1 to 960.6) [500.1 to 833.7]	57.0 to 95.0 (581.2 to 968.7) [504.3 to 840.8]	—	27.7 to 46.1 (282.5 to 470.1) [245.2 to 408.0]	27.9 to 46.5 (284.5 to 474.2) [246.9 to 411.6]	—	56.5 to 94.2 (576.1 to 960.6) [500.1 to 833.7]	—	—		
80 (3.0)	37.3 to 62.2 (380.4 to 634.3) [330.1 to 550.5]	76.0 to 126.7 (775.0 to 1292.0) [672.7 to 1121.4]	—	46.2 to 77.0 (471.1 to 788.2) [408.9 to 681.5]	45.4 to 75.7 (463.0 to 771.9) [401.8 to 670.0]	—	37.3 to 62.2 (380.4 to 634.3) [330.1 to 550.5]	—	75.5 to 125.8 (769.9 to 1282.8) [668.2 to 1113.4]		
100 (4.0)	42.2 to 70.3 (430.3 to 716.9) [373.5 to 622.2]	42.5 to 70.8 (433.4 to 722.0) [376.2 to 626.6]	—	52.0 to 86.7 (530.3 to 884.1) [460.2 to 767.4]	51.2 to 85.3 (522.1 to 869.8) [453.2 to 755.0]	—	42.2 to 70.3 (430.3 to 716.9) [373.5 to 622.2]	—	85.4 to 142.3 (870.8 to 1451.1) [755.9 to 1259.5]		
150 (6.0)	87.8 to 146.4 (895.3 to 1492.9) [777.1 to 1295.7]	86.4 to 144.0 (881.0 to 1468.4) [764.7 to 1274.5]	—	56.8 to 94.7 (579.2 to 1060.5) [502.7 to 838.2]	56.8 to 94.7 (579.2 to 1060.5) [502.7 to 838.2]	—	87.8 to 146.4 (895.3 to 1492.9) [777.1 to 1295.7]	—	95.4 to 159.0 (972.8 to 1621.3) [844.4 to 1407.3]		
200 (8.0)	84.0 to 140.1 (856.6 to 1428.6) [743.5 to 1240.0]	125.4 to 209.1 (1278.7 to 2132.2) [1109.9 to 1850.7]	127.6 to 212.7 (1301.2 to 2168.9) [1129.4 to 1882.6]	91.1 to 151.9 (929.0 to 1548.9) [806.3 to 1344.4]	92.3 to 153.8 (941.3 to 1568.3) [816.9 to 1361.2]	—	84.0 to 140.1 (856.6 to 1428.6) [743.5 to 1240.0]	—	103.0 to 171.7 (1050.3 to 1750.9) [911.6 to 1519.7]		

T0310.EPS

Table 3.3.10 Centering Device Identification (AXF Standard Models, PFA/Polyurethane Rubber/Natural Soft Rubber/EPDM Rubber lining)

Size mm (inch)	Flange ratings	JIS			ANSI		DIN			JPI
		10K	20K	F12 (75M)	Class 150	Class 300	PN10	PN16	PN40	Class 150
50 (2.0)		B	B	—	B	F	—	—	F	B
65 (2.5)		B	B	—	B	G	—	F	—	—
80 (3.0)		B	F	H	F	C	—	G	—	F
100 (4.0)		B	F	H	C	H	—	F	—	C
125 (5.0)		B	C	C	G	D	—	F	—	—
150 (6.0)		C	D	D	C	E	—	C	—	C
200 (8.0)		C	D	D	D	E	C	C	—	D
250 (10)		C	—	D	N	—	C	C	—	N
300 (12)		C	—	D	P	—	C	C	—	P

*: Each centering device is engraved with a character as identification.

T0311.EPS

Table 3.3.11 Centering Device Identification (AXF Standard Models, Ceramics lining)

Size mm (inch)	Flange ratings	JIS			ANSI		DIN		
		10K	20K	F12(75M)	Class 150	Class 300	PN10	PN16	PN40
50 (2.0)		B	B	—	B	F	—	—	F
80 (3.0)		B	F	H	F	C	—	G	—
100 (4.0)		B	F	H	C	H	—	F	—
150 (6.0)		B	C	G	B	D	—	B	—
200 (8.0)		B	C	C	G	J	B	B	—

*: Each centering device is engraved with a character as identification.

T0312-1.EPS

Table 3.3.12 Centering Device Identification (Replacement Models, PFA/Polyurethane Rubber lining)

Size mm (inch)	Flange ratings	JIS			ANSI		DIN		
		10K	20K	F12(75M)	Class 150	Class 300	PN10	PN16	PN40
50 (2.0)		B	B	—	B	F	—	—	F
80 (3.0)		B	F	H	F	C	—	G	—
100 (4.0)		B	F	H	C	H	—	F	—
150 (6.0)		C	D	D	C	E	—	C	—
200 (8.0)		C	D	D	D	E	C	C	—

*: Each centering device is engraved with a character as identification.

T0312-2.EPS

3.3.4 Nominal Diameter 2.5 mm (0.1 in.) to 400 mm (16 in.), Flange Type



IMPORTANT

Use bolts and nuts in compliance with the flange ratings. Be sure to choose a gasket with inner and outer diameters that does not protrude inside the piping (refer to Table 3.3.16). If the inner diameter of the gasket is too large, or outer diameter of the gasket is too small, fluid leakage may result.

(1) Mounting Direction

Mount the flowmeter so that the flow direction of the fluid to be measured is in line with the direction of the arrow mark on the flowmeter.



IMPORTANT

If it is impossible to match the direction of the arrow mark, the direction of the electrical connection can be changed. Refer to Section 5.1 to do this properly.

In case the fluid being measured flows against the arrow direction, refer to the parameter **J20: Flow Direction** in the user's manual of the AXFA11 Magnetic Flowmeter Remote Converter (IM 01E20C01-01E) or the AXFA14 Magnetic Flowmeter Remote Converter/AXF Integral Flowmeter [Software Edition] (IM 01E20C02-01E).

(2) Tightening Nuts

Tighten the bolts according to the torque values for the metal piping in Table 3.3.13. For PVC piping, select an optional code of GA, GC, or GD, use rubber gaskets and tighten the nuts to the torque values for the PVC piping in Table 3.3.14.

For permeable fluids (such as nitric acid, hydrofluoric acid, or sodium hydrate at high temperatures), tighten the nuts according to the torque values in Table 3.3.15.



CAUTION

For a flowmeter with fluorocarbon PFA lining, it is possible that the nuts may loosen as time passes, so tighten them regularly. Be sure to tighten the nuts according to the prescribed torque values. Tighten them diagonally with the same torque values, step by step up to the prescribed torque value.

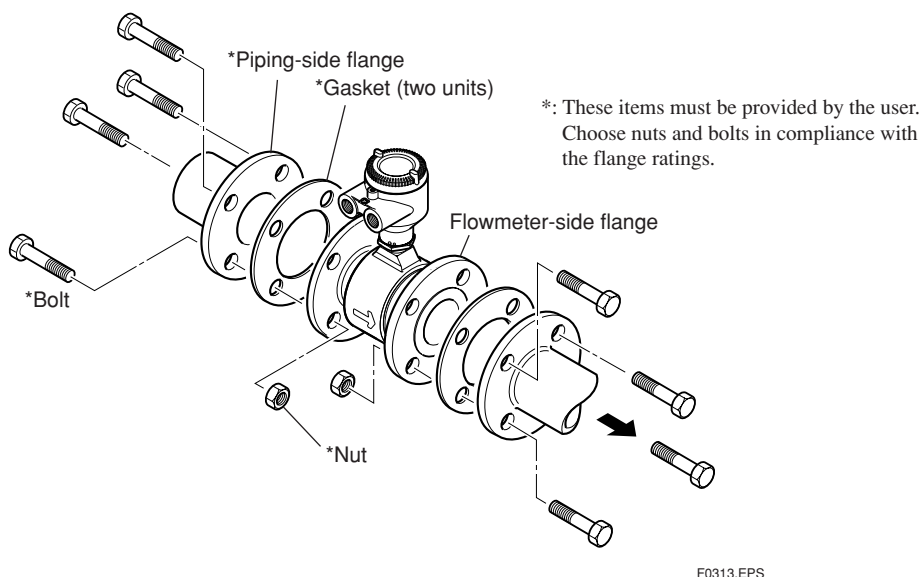

Figure 3.3.5 Mounting Procedure for Flange Type (size: 2.5 mm (0.1 in.) to 400 mm (16 in.))

Table 3.3.13 Flange Type Tightening Torque Values for Metal Piping

Tightening torque values for PFA/Polyurethane Rubber/Natural Soft Rubber/EPDM Rubber lining type												Unit:	N·m (kgf·cm) (in·lbf)
Gasket types within flowtube	No gasket (standard)											AS Table D	AS Table E
	Non-asbestos gasket, PTFE-sheathed non-asbestos gasket, or the equivalent in hardness												
Size mm (inch)	JIS 10K	ANSI Class 150	DIN PN10	JIS 20K	ANSI Class 300	DIN PN16	DIN PN40	JIS F12 (JIS 75M)	JPI Class 150	AS Table D	AS Table E		
2.5 (0.1) (with 10-mm flanges)	3.8 to 6.3 (38.75 to 64.24) (33.63 to 55.76)	3.8 to 6.3 (38.75 to 64.24) (33.63 to 55.76)	—	3.8 to 6.3 (38.75 to 64.24) (33.63 to 55.76)	3.8 to 6.3 (38.75 to 64.24) (33.63 to 55.76)	—	—	—	—	—	—	—	—
2.5 (0.1) (with 15-mm flanges)	4.6 to 7.7 (46.91 to 78.52) (40.71 to 68.15)	4.6 to 7.7 (46.91 to 78.52) (40.71 to 68.15)	—	4.7 to 7.8 (47.93 to 79.54) (41.6 to 69.03)	4.7 to 7.8 (47.93 to 79.54) (41.6 to 69.03)	—	—	—	5.1 to 8.5 (52.1 to 86.8) (45.2 to 75.3)	—	—	—	—
5 (0.2) (with 10-mm flanges)	3.8 to 6.3 (38.75 to 64.24) (33.63 to 55.76)	3.8 to 6.3 (38.75 to 64.24) (33.63 to 55.76)	—	3.8 to 6.3 (38.75 to 64.24) (33.63 to 55.76)	3.8 to 6.3 (38.75 to 64.24) (33.63 to 55.76)	—	—	—	—	—	—	—	—
5 (0.2) (with 15-mm flanges)	4.6 to 7.7 (46.91 to 78.52) (40.71 to 68.15)	4.6 to 7.7 (46.91 to 78.52) (40.71 to 68.15)	—	4.7 to 7.8 (47.93 to 79.54) (41.6 to 69.03)	4.7 to 7.8 (47.93 to 79.54) (41.6 to 69.03)	—	—	—	5.1 to 8.5 (52.1 to 86.8) (45.2 to 75.3)	—	—	—	—
10 (0.4) (with 10-mm flanges)	3.8 to 6.3 (38.75 to 64.24) (33.63 to 55.76)	3.8 to 6.3 (38.75 to 64.24) (33.63 to 55.76)	—	3.8 to 6.3 (38.75 to 64.24) (33.63 to 55.76)	3.8 to 6.3 (38.75 to 64.24) (33.63 to 55.76)	—	—	—	—	—	—	—	—
10 (0.4) (with 15-mm flanges)	4.6 to 7.7 (46.91 to 78.52) (40.71 to 68.15)	4.6 to 7.7 (46.91 to 78.52) (40.71 to 68.15)	—	4.7 to 7.8 (47.93 to 79.54) (41.6 to 69.03)	4.7 to 7.8 (47.93 to 79.54) (41.6 to 69.03)	—	—	—	5.1 to 8.5 (52.1 to 86.8) (45.2 to 75.3)	—	—	—	—
15 (0.5)	4.6 to 7.7 (46.91 to 78.52) (40.71 to 68.15)	4.6 to 7.7 (46.91 to 78.52) (40.71 to 68.15)	—	4.7 to 7.8 (47.93 to 79.54) (41.6 to 69.03)	4.7 to 7.8 (47.93 to 79.54) (41.6 to 69.03)	—	—	—	5.1 to 8.5 (52.1 to 86.8) (45.2 to 75.3)	—	—	—	—
25 (1.0)	13.1 to 15.1 (133.6 to 154.0) (115.9 to 133.6)	13.1 to 15.1 (133.6 to 154.0) (115.9 to 133.6)	—	13.2 to 15.2 (134.6 to 155.0) (116.8 to 134.5)	13.2 to 15.2 (134.6 to 155.0) (116.8 to 134.5)	—	—	—	11.0 to 12.6 (112.1 to 128.9) (97.3 to 111.8)	—	—	—	—
32 (1.25)	14.4 to 15.6 (146.8 to 159.1) (127.4 to 138.1)	14.4 to 15.6 (146.8 to 159.1) (127.4 to 138.1)	—	14.6 to 16.8 (148.9 to 171.3) (129.2 to 148.7)	14.6 to 16.8 (148.9 to 171.3) (129.2 to 148.7)	—	—	—	—	—	—	—	—
40 (1.5)	21.9 to 25.2 (223.3 to 257.0) (193.8 to 223.0)	21.9 to 25.2 (223.3 to 257.0) (193.8 to 223.0)	—	22.2 to 25.5 (226.4 to 260.0) (196.5 to 225.7)	22.2 to 25.5 (226.4 to 260.0) (196.5 to 225.7)	—	—	—	18.3 to 20.3 (186.6 to 207.4) (161.8 to 179.9)	—	—	—	—
50 (2.0)	28.0 to 32.2 (285.8 to 328.3) (247.8 to 285.0)	28.0 to 32.2 (285.8 to 328.3) (247.8 to 285.0)	—	27.8 to 32.0 (283.5 to 326.3) (246.0 to 283.2)	27.8 to 32.0 (283.5 to 326.3) (246.0 to 283.2)	—	—	—	26.2 to 30.0 (267.0 to 305.8) (231.6 to 265.2)	26.2 to 30.0 (267.0 to 305.8) (231.6 to 265.2)	26.6 to 30.5 (271.8 to 311.0) (235.7 to 269.8)	—	—
65 (2.5)	41.6 to 47.8 (424.2 to 487.4) (368.2 to 423.0)	41.6 to 47.8 (424.2 to 487.4) (368.2 to 423.0)	—	19.5 to 28.5 (198.8 to 290.6) (172.6 to 232.2)	19.5 to 28.5 (198.8 to 290.6) (172.6 to 232.2)	—	—	—	—	—	—	—	—
80 (3.0)	23.2 to 26.7 (236.2 to 272.3) (205.3 to 236.3)	23.2 to 26.7 (236.2 to 272.3) (205.3 to 236.3)	—	26.1 to 30.0 (266.1 to 305.9) (231.0 to 265.5)	26.1 to 30.0 (266.1 to 305.9) (231.0 to 265.5)	—	—	—	46.0 to 52.9 (469.1 to 539.4) (407.1 to 468.2)	46.0 to 52.9 (469.1 to 539.4) (407.1 to 468.2)	44.1 to 50.5 (450.2 to 515.4) (390.5 to 447.0)	45.4 to 51.9 (463.6 to 530.0) (402.1 to 459.7)	—
100 (4.0)	30.9 to 35.5 (315.1 to 362.0) (273.5 to 314.2)	30.9 to 35.5 (315.1 to 362.0) (273.5 to 314.2)	—	34.8 to 40.0 (354.9 to 407.9) (308.0 to 354.0)	34.8 to 40.0 (354.9 to 407.9) (308.0 to 354.0)	—	—	—	60.9 to 70.0 (621.0 to 713.8) (539.0 to 619.5)	60.9 to 70.0 (621.0 to 713.8) (539.0 to 619.5)	58.1 to 66.5 (593.3 to 678.9) (514.6 to 588.8)	29.6 to 33.8 (301.6 to 344.7) (261.6 to 299.0)	—
125 (5.0)	45.0 to 52.4 (465.0 to 534.3) (403.6 to 463.8)	45.0 to 52.4 (465.0 to 534.3) (403.6 to 463.8)	—	48.6 to 55.9 (495.6 to 570.0) (430.1 to 494.7)	48.6 to 55.9 (495.6 to 570.0) (430.1 to 494.7)	—	—	—	48.1 to 55.3 (490.5 to 563.9) (425.7 to 489.4)	48.1 to 55.3 (490.5 to 563.9) (425.7 to 489.4)	—	—	—
150 (6.0)	64.5 to 74.2 (657.1 to 756.6) (570.8 to 656.7)	64.5 to 74.2 (657.1 to 756.6) (570.8 to 656.7)	—	44.8 to 51.5 (456.8 to 525.2) (396.5 to 455.8)	44.8 to 51.5 (456.8 to 525.2) (396.5 to 455.8)	—	—	—	67.5 to 77.6 (688.2 to 791.3) (597.4 to 686.8)	67.5 to 77.6 (688.2 to 791.3) (597.4 to 686.8)	60.5 to 66.3 (617.7 to 676.5) (535.8 to 586.8)	47.0 to 53.8 (479.5 to 548.5) (415.9 to 475.8)	60.3 to 66.7 (615.5 to 681.0) (533.8 to 590.7)
200 (8.0)	59.2 to 68.1 (603.7 to 694.4) (523.9 to 602.7)	59.2 to 68.1 (603.7 to 694.4) (523.9 to 602.7)	100.3 to 102.1 (1023 to 1041) (887.8 to 903.3)	63.6 to 73.1 (648.5 to 745.4) (562.9 to 647.0)	63.6 to 73.1 (648.5 to 745.4) (562.9 to 647.0)	—	—	—	69.9 to 80.4 (712.8 to 819.9) (618.6 to 711.6)	69.9 to 80.4 (712.8 to 819.9) (618.6 to 711.6)	84.9 to 93.0 (866.2 to 949.5) (579.6 to 662.6)	65.8 to 74.9 (668.2 to 763.9) (579.6 to 662.6)	85.9 to 95.2 (876.2 to 972.0) (760.0 to 842.7)
250 (10)	144.0 to 165.6 (1468 to 1689) (1274 to 1466)	144.0 to 165.6 (1468 to 1689) (1274 to 1466)	144.0 to 165.6 (1468 to 1689) (1274 to 1466)	154.0 to 179.7 (1594 to 1832) (1383 to 1590)	154.0 to 179.7 (1594 to 1832) (1383 to 1590)	—	—	—	190.5 to 219.1 (1943 to 2234) (1686 to 1939)	190.5 to 219.1 (1943 to 2234) (1686 to 1939)	142.1 to 160.5 (1450 to 1638) (1258 to 1421)	161.7 to 178.4 (1659 to 1821) (1431 to 1579)	114.1 to 126.3 (1164 to 1289) (1010 to 1118)
300 (12)	119.3 to 137.2 (1217 to 1399) (1056 to 1214)	119.3 to 137.2 (1217 to 1399) (1056 to 1214)	163.1 to 197.4 (1663 to 2013) (1443 to 1747)	123.1 to 136.3 (1255 to 1390) (1089 to 1206)	123.1 to 136.3 (1255 to 1390) (1089 to 1206)	—	—	—	168.0 to 193.2 (1713 to 1970) (1487 to 1710)	168.0 to 193.2 (1713 to 1970) (1487 to 1710)	158.5 to 178.9 (1617 to 1826) (1402 to 1584)	119.3 to 131.8 (1193 to 1318) (1035 to 1143)	149.7 to 163.1 (1527 to 1664) (1325 to 1444)
350 (14)	164.7 to 189.4 (1679 to 1931) (1458 to 1676)	164.7 to 189.4 (1679 to 1931) (1458 to 1676)	226.4 to 263.5 (2269 to 2596) (1943 to 2247)	225.2 to 258.9 (2296 to 2640) (1993 to 2291)	225.2 to 258.9 (2296 to 2640) (1993 to 2291)	—	—	—	243.0 to 265.2 (2433 to 2798) (2112 to 2429)	243.0 to 265.2 (2433 to 2798) (2112 to 2429)	233.1 to 254.4 (2378 to 2596) (2063 to 2252)	267.1 to 291.3 (2725 to 2972) (2364 to 2578)	—
400 (16)	225.2 to 258.9 (2296 to 2640) (1993 to 2291)	225.2 to 258.9 (2296 to 2640) (1993 to 2291)	225.2 to 258.9 (2296 to 2640) (1993 to 2291)	225.2 to 258.9 (2296 to 2640) (1993 to 2291)	225.2 to 258.9 (2296 to 2640) (1993 to 2291)	—	—	—	305.8 to 351.7 (3118 to 3586) (2706 to 3113)	305.8 to 351.7 (3118 to 3586) (2706 to 3113)	233.1 to 254.4 (2378 to 2596) (2063 to 2252)	267.1 to 291.3 (2725 to 2972) (2364 to 2578)	—

T0314.EPS

3. INSTALLATION

Table 3.3.14 Flange Type Tightening Torque Values for PVC Piping

Tightening torque values for PFA lining type												Unit:	N-m (kgfcm) (in-lbf)
Gasket types within flowtube	Fluororubber gasket (optional codes GA, GC, and GD)												
Gasket types for user's flange	Fluororubber gasket, chloroprene rubber gasket, or the equivalent in hardness												
Flange ratings	JIS 10K	ANSI Class 150	DIN PN10	JIS 20K	ANSI Class 300	DIN PN16	DIN PN40	JIS F12 (JIS 75M)	JPI Class 150	AS Table D	AS Table E		
Size mm (inch)													
2.5 (0.1) (with 10-mm flanges)	0.8 to 1.3 (8.158 to 13.26) [7.08 to 11.51]	0.8 to 1.3 (8.158 to 13.26) [7.08 to 11.51]	—	0.8 to 1.3 (8.158 to 13.26) [7.08 to 11.51]	0.8 to 1.3 (8.158 to 13.26) [7.08 to 11.51]	—	—	0.8 to 1.3 (8.158 to 13.26) [7.08 to 11.51]	—	—	—	—	—
2.5 (0.1) (with 15-mm flanges)	0.9 to 1.6 (9.177 to 16.32) [7.966 to 14.16]	0.9 to 1.6 (9.177 to 16.32) [7.966 to 14.16]	—	0.9 to 1.6 (9.177 to 16.32) [7.966 to 14.16]	0.9 to 1.6 (9.177 to 16.32) [7.966 to 14.16]	—	—	0.9 to 1.6 (9.177 to 16.32) [7.966 to 14.16]	—	1.0 to 1.7 (10.5 to 16.8) [9.1 to 14.6]	—	—	—
5 (0.2) (with 10-mm flanges)	0.8 to 1.3 (8.158 to 13.26) [7.08 to 11.51]	0.8 to 1.3 (8.158 to 13.26) [7.08 to 11.51]	—	0.8 to 1.3 (8.158 to 13.26) [7.08 to 11.51]	0.8 to 1.3 (8.158 to 13.26) [7.08 to 11.51]	—	—	0.8 to 1.3 (8.158 to 13.26) [7.08 to 11.51]	—	—	—	—	—
5 (0.2) (with 15-mm flanges)	0.9 to 1.6 (9.177 to 16.32) [7.966 to 14.16]	0.9 to 1.6 (9.177 to 16.32) [7.966 to 14.16]	—	0.9 to 1.6 (9.177 to 16.32) [7.966 to 14.16]	0.9 to 1.6 (9.177 to 16.32) [7.966 to 14.16]	—	—	0.9 to 1.6 (9.177 to 16.32) [7.966 to 14.16]	—	1.0 to 1.7 (10.5 to 16.8) [9.1 to 14.6]	—	—	—
10 (0.4) (with 10-mm flanges)	0.8 to 1.3 (8.158 to 13.26) [7.08 to 11.51]	0.8 to 1.3 (8.158 to 13.26) [7.08 to 11.51]	—	0.8 to 1.3 (8.158 to 13.26) [7.08 to 11.51]	0.8 to 1.3 (8.158 to 13.26) [7.08 to 11.51]	—	—	0.8 to 1.3 (8.158 to 13.26) [7.08 to 11.51]	—	—	—	—	—
10 (0.4) (with 15-mm flanges)	0.9 to 1.6 (9.177 to 16.32) [7.966 to 14.16]	0.9 to 1.6 (9.177 to 16.32) [7.966 to 14.16]	—	0.9 to 1.6 (9.177 to 16.32) [7.966 to 14.16]	0.9 to 1.6 (9.177 to 16.32) [7.966 to 14.16]	—	—	0.9 to 1.6 (9.177 to 16.32) [7.966 to 14.16]	—	1.0 to 1.7 (10.5 to 16.8) [9.1 to 14.6]	—	—	—
15 (0.5)	0.9 to 1.6 (9.177 to 16.32) [7.966 to 14.16]	0.9 to 1.6 (9.177 to 16.32) [7.966 to 14.16]	—	0.9 to 1.6 (9.177 to 16.32) [7.966 to 14.16]	0.9 to 1.6 (9.177 to 16.32) [7.966 to 14.16]	—	—	0.9 to 1.6 (9.177 to 16.32) [7.966 to 14.16]	—	1.0 to 1.7 (10.5 to 16.8) [9.1 to 14.6]	—	—	—
25 (1.0)	2.7 to 4.5 (27.53 to 45.89) [23.9 to 39.83]	2.7 to 4.5 (27.53 to 45.89) [23.9 to 39.83]	—	2.7 to 4.5 (27.53 to 45.89) [23.9 to 39.83]	2.7 to 4.5 (27.53 to 45.89) [23.9 to 39.83]	—	—	2.7 to 4.5 (27.53 to 45.89) [23.9 to 39.83]	—	2.3 to 3.9 (22.8 to 36.9) [19.8 to 32.0]	—	—	—
32 (1.25)	3.0 to 4.9 (30.59 to 49.97) [26.55 to 44.25]	3.0 to 4.9 (30.59 to 49.97) [26.55 to 44.25]	—	3.0 to 4.9 (30.59 to 49.97) [26.55 to 44.25]	3.0 to 4.9 (30.59 to 49.97) [26.55 to 44.25]	—	—	3.0 to 4.9 (30.59 to 49.97) [26.55 to 44.25]	—	—	—	—	—
40 (1.5)	4.3 to 7.6 (45.89 to 77.5) [39.83 to 67.26]	4.3 to 7.6 (45.89 to 77.5) [39.83 to 67.26]	—	4.3 to 7.6 (45.89 to 77.5) [39.83 to 67.26]	4.3 to 7.6 (45.89 to 77.5) [39.83 to 67.26]	—	—	4.3 to 7.6 (45.89 to 77.5) [39.83 to 67.26]	—	3.8 to 6.2 (38.6 to 62.8) [33.5 to 54.4]	—	—	—
50 (2.0)	5.9 to 9.8 (60.16 to 99.93) [52.22 to 86.74]	5.9 to 9.8 (60.16 to 99.93) [52.22 to 86.74]	—	5.9 to 9.8 (60.16 to 99.93) [52.22 to 86.74]	5.9 to 9.8 (60.16 to 99.93) [52.22 to 86.74]	—	—	5.9 to 9.8 (60.16 to 99.93) [52.22 to 86.74]	—	5.3 to 8.8 (54.1 to 89.8) [47.0 to 77.9]	—	—	—
65 (2.5)	9.1 to 15.4 (91.8 to 153.0) [79.7 to 132.8]	9.1 to 15.4 (91.8 to 153.0) [79.7 to 132.8]	—	9.1 to 15.4 (91.8 to 153.0) [79.7 to 132.8]	9.1 to 15.4 (91.8 to 153.0) [79.7 to 132.8]	—	—	9.1 to 15.4 (91.8 to 153.0) [79.7 to 132.8]	—	—	—	—	—
80 (3.0)	11.1 to 16.3 (113.2 to 166.2) [98.2 to 144.3]	11.1 to 16.3 (113.2 to 166.2) [98.2 to 144.3]	—	11.1 to 16.3 (113.2 to 166.2) [98.2 to 144.3]	11.1 to 16.3 (113.2 to 166.2) [98.2 to 144.3]	—	—	11.1 to 16.3 (113.2 to 166.2) [98.2 to 144.3]	—	—	—	—	—
100 (4.0)	17.7 to 28.5 (178.8 to 285.1) [155.9 to 244.9]	17.7 to 28.5 (178.8 to 285.1) [155.9 to 244.9]	—	17.7 to 28.5 (178.8 to 285.1) [155.9 to 244.9]	17.7 to 28.5 (178.8 to 285.1) [155.9 to 244.9]	—	—	17.7 to 28.5 (178.8 to 285.1) [155.9 to 244.9]	—	—	—	—	—
125 (5.0)	24.7 to 40.8 (247.8 to 408.0) [213.8 to 360.6]	24.7 to 40.8 (247.8 to 408.0) [213.8 to 360.6]	—	24.7 to 40.8 (247.8 to 408.0) [213.8 to 360.6]	24.7 to 40.8 (247.8 to 408.0) [213.8 to 360.6]	—	—	24.7 to 40.8 (247.8 to 408.0) [213.8 to 360.6]	—	—	—	—	—
150 (6.0)	33.9 to 55.4 (339.1 to 554.2) [293.1 to 495.1]	33.9 to 55.4 (339.1 to 554.2) [293.1 to 495.1]	—	33.9 to 55.4 (339.1 to 554.2) [293.1 to 495.1]	33.9 to 55.4 (339.1 to 554.2) [293.1 to 495.1]	—	—	33.9 to 55.4 (339.1 to 554.2) [293.1 to 495.1]	—	—	—	—	—
200 (8.0)	51.2 to 84.4 (512.0 to 844.0) [443.8 to 743.8]	51.2 to 84.4 (512.0 to 844.0) [443.8 to 743.8]	—	51.2 to 84.4 (512.0 to 844.0) [443.8 to 743.8]	51.2 to 84.4 (512.0 to 844.0) [443.8 to 743.8]	—	—	51.2 to 84.4 (512.0 to 844.0) [443.8 to 743.8]	—	—	—	—	—

T0315.EPS

Table 3.3.15 Flange Type Tightening Torque Values for Metal Piping and Permeable Fluids

Tightening torque values for PFA lining type												Unit:	N-m (kgfcm) (in-lbf)
Gasket types within flowtube	No gasket (standard)												
Gasket types for user's flange	Non-asbestos gasket, PTFE-sheathed non-asbestos gasket, or the equivalent in hardness												
Flange ratings	JIS 10K	ANSI Class 150	DIN PN10	JIS 20K	ANSI Class 300	DIN PN16	DIN PN40	JIS F12 (JIS 75M)	JPI Class 150	AS Table D	AS Table E		
Size mm (inch)													
2.5 (0.1) (with 10-mm flanges)	5.7 to 6.6 (58.12 to 67.3) [50.45 to 58.41]	5.7 to 6.6 (58.12 to 67.3) [50.45 to 58.41]	—	5.7 to 6.6 (58.12 to 67.3) [50.45 to 58.41]	5.7 to 6.6 (58.12 to 67.3) [50.45 to 58.41]	—	—	5.7 to 6.6 (58.12 to 67.3) [50.45 to 58.41]	—	—	—	—	—
2.5 (0.1) (with 15-mm flanges)	6.9 to 7.9 (70.36 to 80.56) [61.07 to 69.92]	6.9 to 7.9 (70.36 to 80.56) [61.07 to 69.92]	—	6.9 to 7.9 (70.36 to 80.56) [61.07 to 69.92]	6.9 to 7.9 (70.36 to 80.56) [61.07 to 69.92]	—	—	6.9 to 7.9 (70.36 to 80.56) [61.07 to 69.92]	—	7.6 to 7.8 (77.9 to 79.9) [67.6 to 69.3]	—	—	—
5 (0.2) (with 10-mm flanges)	5.7 to 6.6 (58.12 to 67.3) [50.45 to 58.41]	5.7 to 6.6 (58.12 to 67.3) [50.45 to 58.41]	—	5.7 to 6.6 (58.12 to 67.3) [50.45 to 58.41]	5.7 to 6.6 (58.12 to 67.3) [50.45 to 58.41]	—	—	5.7 to 6.6 (58.12 to 67.3) [50.45 to 58.41]	—	—	—	—	—
5 (0.2) (with 15-mm flanges)	6.9 to 7.9 (70.36 to 80.56) [61.07 to 69.92]	6.9 to 7.9 (70.36 to 80.56) [61.07 to 69.92]	—	6.9 to 7.9 (70.36 to 80.56) [61.07 to 69.92]	6.9 to 7.9 (70.36 to 80.56) [61.07 to 69.92]	—	—	6.9 to 7.9 (70.36 to 80.56) [61.07 to 69.92]	—	7.6 to 7.8 (77.9 to 79.9) [67.6 to 69.3]	—	—	—
10 (0.4) (with 10-mm flanges)	5.7 to 6.6 (58.12 to 67.3) [50.45 to 58.41]	5.7 to 6.6 (58.12 to 67.3) [50.45 to 58.41]	—	5.7 to 6.6 (58.12 to 67.3) [50.45 to 58.41]	5.7 to 6.6 (58.12 to 67.3) [50.45 to 58.41]	—	—	5.7 to 6.6 (58.12 to 67.3) [50.45 to 58.41]	—	—	—	—	—
10 (0.4) (with 15-mm flanges)	6.9 to 7.9 (70.36 to 80.56) [61.07 to 69.92]	6.9 to 7.9 (70.36 to 80.56) [61.07 to 69.92]	—	6.9 to 7.9 (70.36 to 80.56) [61.07 to 69.92]	6.9 to 7.9 (70.36 to 80.56) [61.07 to 69.92]	—	—	6.9 to 7.9 (70.36 to 80.56) [61.07 to 69.92]	—	7.6 to 7.8 (77.9 to 79.9) [67.6 to 69.3]	—	—	—
15 (0.5)	6.9 to 7.9 (70.36 to 80.56) [61.07 to 69.92]	6.9 to 7.9 (70.36 to 80.56) [61.07 to 69.92]	—	6.9 to 7.9 (70.36 to 80.56) [61.07 to 69.92]	6.9 to 7.9 (70.36 to 80.56) [61.07 to 69.92]	—	—	6.9 to 7.9 (70.36 to 80.56) [61.07 to 69.92]	—	7.6 to 7.8 (77.9 to 79.9) [67.6 to 69.3]	—	—	—
25 (1.0)	19.6 to 22.5 (199.9 to 229.4) [173.5 to 199.1]	19.6 to 22.5 (199.9 to 229.4) [173.5 to 199.1]	—	19.6 to 22.5 (199.9 to 229.4) [173.5 to 199.1]	19.6 to 22.5 (199.9 to 229.4) [173.5 to 199.1]	—	—	19.6 to 22.5 (199.9 to 229.4) [173.5 to 199.1]	—	16.4 to 16.8 (167.3 to 171.7) [145.1 to 148.9]	—	—	—
32 (1.25)	21.5 to 24.7 (219.2 to 251.9) [190.3 to 218.6]	21.5 to 24.7 (219.2 to 251.9) [190.3 to 218.6]	—	21.5 to 24.7 (219.2 to 251.9) [190.3 to 218.6]	21.5 to 24.7 (219.2 to 251.9) [190.3 to 218.6]	—	—	21.5 to 24.7 (219.2 to 251.9) [190.3 to 218.6]	—	—	—	—	—
40 (1.5)	32.5 to 37.4 (331.4 to 381.4) [287.6 to 331.0]	32.5 to 37.4 (331.4 to 381.4) [287.6 to 331.0]	—	32.5 to 37.4 (331.4 to 381.4) [287.6 to 331.0]	32.5 to 37.4 (331.4 to 381.4) [287.6 to 331.0]	—	—	32.5 to 37.4 (331.4 to 381.4) [287.6 to 331.0]	—	27.2 to 27.9 (277.2 to 284.8) [240.4 to 247.0]	—	—	—
50 (2.0)	41.3 to 47.5 (421.1 to 484.4) [365.5 to 420.4]	41.3 to 47.5 (421.1 to 484.4) [365.5 to 420.4]	—	41.3 to 47.5 (421.1 to 484.4) [365.5 to 420.4]	41.3 to 47.5 (421.1 to 484.4) [365.5 to 420.4]	—	—	41.3 to 47.5 (421.1 to 484.4) [365.5 to 420.4]	—	39.1 to 41.4 (398.7 to 422.7) [345.9 to 370.8]	—	—	—
65 (2.5)	61.2 to 70.4 (624.1 to 717.9) [541.6 to 623.1]	61.2 to 70.4 (624.1 to 717.9) [541.6 to 623.1]	—	61.2 to 70.4 (624.1 to 717.9) [541.6 to 623.1]	61.2 to 70.4 (624.1 to 717.9) [541.6 to 623.1]	—	—	61.2 to 70.4 (624.1 to 717.9) [541.6 to 623.1]	—	—	—	—	—
80 (3.0)	84.5 to 99.7 (845.2 to 997.0) [735.7 to 831.8]	84.5 to 99.7 (845.2 to 997.0) [735.7 to 831.8]	—	84.5 to 99.7 (845.2 to 997.0) [735.7 to 831.8]	84.5 to 99.7 (845.2 to 997.0) [735.7 to 831.8]	—	—	84.5 to 99.7 (845.2 to 997.0) [735.7 to 831.8]	—	—	—	—	—
100 (4.0)	110.3 to 132.2 (1103.3 to 1322.0) [962.3 to 1160.0]	110.3 to 132.2 (1103.3 to 1322.0) [962.3 to 1160.0]	—	110.3 to 132.2 (1103.3 to 1322.0) [962.3 to 1160.0]	110.3 to 132.2 (1103.3 to 1322.0) [962.3 to 1160.0]	—	—	110.3 to 132.2 (1103.3 to 1322.0) [962.3 to 1160.0]	—	—	—	—	—
125 (5.0)	148.8 to 180.1 (1488.0 to 1801.0) [1288.0 to 1601.0]	148.8 to 180.1 (1488.0 to 1801.0) [1288.0 to 1601.0]	—	148.8 to 180.1 (1488.0 to 1801.0) [1288.0 to 1601.0]	148.8 to 180.1 (1488.0 to 1801.0) [1288.0 to 1601.0]	—	—	148.8 to 180.1 (1488.0 to 1801.0) [1288.0 to 1601.0]	—	—	—	—	—
150 (6.0)	199.2 to 247.8 (1992.0 to 2478.0) [1729.2 to 2167.2]	199.2 to 247.8 (1992.0 to 2478.0) [1729.2 to 2167.2]	—	199.2 to 247.8 (1992.0 to 2478.0) [1729.2 to 2167.2]	199.2 to 247.8 (1992.0 to 2478.0) [1729.2 to 2167.2]	—	—	199.2 to 247.8 (1992.0 to 2478.0) [1729.2 to 2167.2]	—	—	—	—	—
200 (8.0)	293.8 to 360.6 (2938.0 to 3606.0) [2566.6 to 3170.6]	293.8 to 360.6 (2938.0 to 3606.0) [2566.6 to 3170.6]	—	293.8 to 360.6 (2938.0 to 3606.0) [2566.6 to 3170.6]	293.8 to 360.6 (2938.0 to 3606.0) [2566.6 to 3170.6]	—	—	293.8 to 360.6 (2938.0 to 3606.0) [2566.6 to 3170.6]	—	—	—	—	—

T0316.EPS

3.3.5 Gaskets Size

Be sure to choose a gasket with an inner and outer diameter that does not protrude inside the piping.

If the inner diameter of the gasket is too large, or outer diameter of the gasket is too small, fluid leakage may result.

Table 3.3.16 Inner Diameter of Grounding Ring, Outer Diameter for Effective Sealing and Recommended Inner Diameter of Gasket

AXF Standard: Unit : mm (in.)

Size	PFA/ Polyurethane Rubber/ Natural Soft Rubber/ EPDM Rubber								Ceramics				
	Wafer				Flange				Inner Diameter of Grounding Ring [øA]	Outer Diameter for Effective Sealing [øB]	Recommended Inner Diameter of Gasket		
	Inner Diameter of Grounding Ring [øA]	Outer Diameter for Effective Sealing [øB]	Recommended Inner Diameter of Gasket		Inner Diameter of Grounding Ring [øA]	Outer Diameter for Effective Sealing [øB]	Recommended Inner Diameter of Gasket				Inner Diameter of Grounding Ring [øA]	Outer Diameter for Effective Sealing [øB]	Recommended Inner Diameter of Gasket
		Flat Gasket [øC]	PTFE-sheathed Non-asbestos Gasket [øD]			Flat Gasket [øC]	PTFE-sheathed Non-asbestos Gasket [øD]			Flat Gasket [øC]			PTFE-sheathed Non-asbestos Gasket [øD]
2.5 (0.1)	15 (0.59)	38 (1.50)	17 (0.67)	22 (0.87)	15 (0.59) [12 (0.47)] *1	30 (1.18)	17 (0.67) [15 (0.59)]*1	22 (0.87) [19 (0.75)]*1	-	-	-	-	-
5 (0.2)	15 (0.59)	38 (1.50)	17 (0.67)	22 (0.87)	15 (0.59) [12 (0.47)] *1	30 (1.18)	17 (0.67) [15 (0.59)]*1	22 (0.87) [19 (0.75)]*1	-	-	-	-	-
10 (0.4)	15 (0.59)	38 (1.50)	17 (0.67)	22 (0.87)	15 (0.59) [12 (0.47)] *1	30 (1.18)	17 (0.67) [15 (0.59)]*1	22 (0.87) [19 (0.75)]*1	-	-	-	-	-
15 (0.5)	15 (0.59)	38 (1.50)		22 (0.87)	15 (0.59)	34 (1.34)		22 (0.87)	15 (0.59)	33 (1.30)		22 (0.87)	
25 (1.0)	28 (1.10)	53 (2.09)		35 (1.38)	28 (1.10)	53 (2.09)		35 (1.38)	27 (1.06)	50 (1.97)		35 (1.38)	
32 (1.25)	34 (1.34)	58 (2.28)		43 (1.69)	34 (1.34)	58 (2.28)		43 (1.69)					
40 (1.5)	41 (1.61)	71 (2.80)		49 (1.93)	41 (1.61)	71 (2.80)		49 (1.93)	40 (1.57)	68 (2.68)		49 (1.93)	
50 (2.0)	53 (2.09)	84 (3.31)		61 (2.40)	53 (2.09)	84 (3.31)		61 (2.40)	52 (2.05)	82 (3.23)		61 (2.40)	
65 (2.5)	66 (2.60)	103 (4.06)		84 (3.31)	66 (2.60)	103 (4.06)		84 (3.31)					
80 (3.0)	77 (3.03)	114 (4.49)		90 (3.54)	77 (3.03)	114 (4.49)		90 (3.54)	81 (3.19)	112 (4.41)		90 (3.54)	
100 (4.0)	102 (4.02)	140 (5.51)		115 (4.53)	102 (4.02)	140 (5.51)		115 (4.53)	98 (3.86)	134 (5.28)		115 (4.53)	
125 (5.0)	128 (5.04)	165 (6.50)		141 (5.55)	128 (5.04)	165 (6.50)		141 (5.55)					
150 (6.0)	146.1 (5.75)	190 (7.48)		167 (6.57)	146.1 (5.75)	190 (7.48)		167 (6.57)	144 (5.67)	188 (7.40)		167 (6.57)	
200 (8.0)	193.6 (7.62)	240 (9.45)		218 (8.58)	193.6 (7.62)	240 (9.45)		218 (8.58)	192 (7.56)	240 (9.45)		218 (8.58)	
250 (10)	243.7 (9.59)	300 (11.81)		270 (10.63)	243 (9.57)	315 (12.40)		270 (10.63)					
300 (12)	294.7 (11.60)	348 (13.70)		321 (12.64)	291.3 (11.47)	360 (14.17)		321 (12.64)					
350 (14)	-	-		-	323.4 (12.73)	405 (15.94)		359 (14.13)					
400 (16)	-	-		-	373.5 (14.70)	465 (18.31)		410 (16.14)					

*1: The inner diameter of the process connection code: DD4, DJ1, DJ2 is values in brackets [].

T25.EPS

Replacement Model for earlier ADMAG or ADMAG AE:

Unit : mm (in.)

Size	PFA/ Polyurethane Rubber							
	Wafer				Flange			
	Inner Diameter of Grounding Ring [øA]	Outer Diameter for Effective Sealing [øB]	Recommended Inner Diameter of Gasket		Inner Diameter of Grounding Ring [øA]	Outer Diameter for Effective Sealing [øB]	Recommended Inner Diameter of Gasket	
		Flat Gasket [øC]	PTFE-sheathed Non-asbestos Gasket [øD]			Flat Gasket [øC]	PTFE-sheathed Non-asbestos Gasket [øD]	
2.5 (0.1)	15 (0.59)	38 (1.50)	17 (0.67)	22 (0.87)	-	-	-	-
5 (0.2)	15 (0.59)	38 (1.50)	17 (0.67)	22 (0.87)	-	-	-	-
10 (0.4)	15 (0.59)	38 (1.50)	17 (0.67)	22 (0.87)	-	-	-	-
15 (0.5)	15 (0.59)	38 (1.50)		22 (0.87)	-	-	-	-
25 (1.0)	27 (1.06)	56 (2.20)		35 (1.38)	-	-	-	-
40 (1.5)	40 (1.57)	71 (2.80)		49 (1.93)	-	-	-	-
50 (2.0)	52 (2.05)	85 (3.35)		61 (2.40)	-	-	-	-
80 (3.0)	81 (3.19)	115 (4.53)		90 (3.54)	-	-	-	-
100 (4.0)	98 (3.86)	144 (5.67)		115 (4.53)	-	-	-	-
150 (6.0)	140.7 (5.54)	190 (7.48)		167 (6.57)	140.7 (5.54)	205 (8.07)		167 (6.57)
200 (8.0)	188.9 (7.44)	240 (9.45)		218 (8.58)	188.9 (7.44)	255 (10.04)		218 (8.58)
250 (10)	-	-		-	243 (9.57)	315 (12.40)		270 (10.63)

T16-3.EPS

Size of Inner Diameter of Grounding Ring, Outer Diameter for Effective Sealing and Recommended Inner Diameter of Gasket:

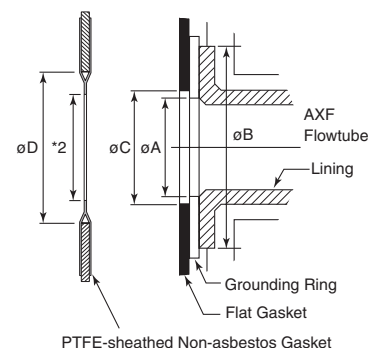

*2: Do not have this length be smaller than the inner diameter of grounding ring (øA).

3.3.6 Nominal Diameter 15 mm (0.5 in.) to 125 mm (5.0 in.), Sanitary Type

The sanitary type can be mounted to the piping using a clamps, a unions, or a welded joints.



NOTE

This section describes the remote flowtube as an example. The same procedure also applies to the integral flowmeter.

Sanitary adapters are engraved with character as identification.

Table 3.3.17 Sanitary Adapter Identification

Identification Character	Material for Adapter
No mark	SUS304
F	SUSF304
L	SUS316L
FL	SUSF316L

T3.3.20.EPS

(1) Mounting Direction

Mount the flowmeter so that the flow direction of the fluid to be measured is in line with the direction of the arrow mark on the flowmeter.



IMPORTANT

If it is impossible to match the direction of the arrow mark, the direction of the electrical connection can be changed. Refer to Section 5.1 to do this properly.

In case the fluid being measured flows against the arrow direction, refer to the parameter **J20: Flow Direction** in the user's manual of the AXFA11 Magnetic Flowmeter Remote Converter (IM 01E20C01-01E) or the AXFA14 Magnetic Flowmeter Remote Converter/AXF Integral Flowmeter [Software Edition] (IM 01E20C02-01E).

(2) Mounting Procedure

(a) Clamp type

(process connection codes: HAB, HDB, and HKB)

1) Welding ferrule

Weld a ferrule to the piping.



IMPORTANT

When welding the ferrule, pay attention to the edge preparation, level differences between the ferrule and the piping, and the welding current to avoid deforming the piping or causing stagnation portion of the fluid.

2) Installing gasket

Install a gasket for clamp to fit in the groove on the ferrule.

3) Positioning flowmeter

Position the flowmeter between the two ferrules.

4) Tightening clamp

Install a clamp to cover the tapered parts of the flowmeter-side adapter and the ferrule, and tighten the clamp screw.

5) Confirmation of adapter mounting screw

After installation of the magnetic flowmeter, be sure to retighten the adapter mounting screw according to Table 3.3.18 or Table 3.3.19.

Be sure to confirm that leakage from adapter connection point does not occur by filling the pipe of the flowtube with fluid.



NOTE

The ferrule, clamp, and gasket are not provided with the flowmeter, and must be provided by the user.

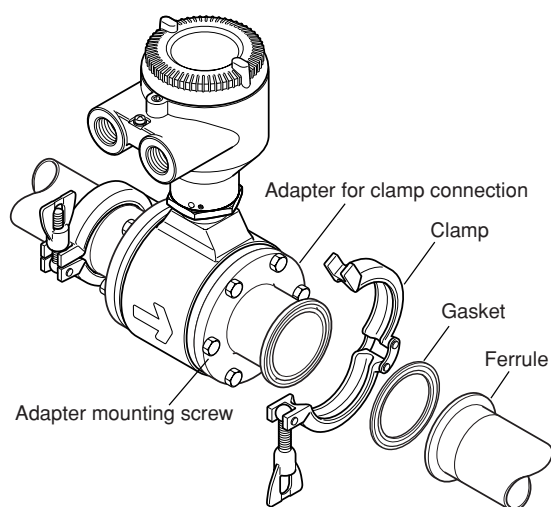

F0314.EPS

Figure 3.3.6 Mounting Procedure for Clamp Connection Type

(b) Union type

(process connection codes: JDB, JKB, and JSB)

1) Welding sleeve

Pass the piping through a nut and then weld a sleeve to the piping.

**IMPORTANT**

- Be sure to weld the sleeve after passing the piping through the nut.
- When welding the sleeve, pay attention to the edge preparation, level differences between the sleeve and the piping, and the welding current to avoid deforming the piping or causing stagnation of some of the fluid.

2) Installing gasket

Install a gasket for union to fit in the groove on the sleeve.

3) Positioning flowmeter

Move the nut closer to the piping temporarily and position the flowmeter between the two sleeves.

4) Tightening nut

Install the nut to cover the tapered parts of the flowmeter-side adapter and the sleeve, and tighten it using a wrench.

5) Confirmation of adapter mounting screw

After installation of the magnetic flowmeter, be sure to retighten the adapter mounting screw according to Table 3.3.18 or Table 3.3.19.

Be sure to confirm that leakage from adapter connection point does not occur by filling the pipe of the flowtube with fluid.

**NOTE**

The sleeve, nut, and gasket are not provided with the flowmeter, and must be provided by the user.

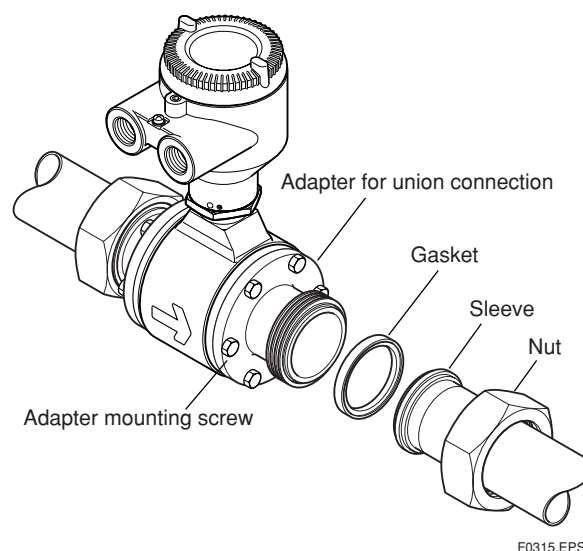

Figure 3.3.7 Mounting Procedure for Union Connection Type

(c) Butt weld adapter type

(process connection codes: KDB and KKB)

1) Removing adapter

Remove the butt weld adapter by loosening the mounting screws.

2) Welding ferrule or sleeve

Weld a ferrule, a sleeve, or an alternative (provided by the user) to the butt weld adapter.

**IMPORTANT**

- Be sure to weld the ferrule, the sleeve, or the alternative after removing the butt weld adapter from the flowmeter itself.
- When welding the ferrule, the sleeve, or the alternative, pay attention to the edge preparation, level differences between them and the piping, and the welding current to avoid deforming the piping or causing stagnation portion of the fluid.

3) Installing butt weld adapter

Install a gasket to fit in the groove of the butt weld adapter, and tighten the mounting screws.

CAUTION

- In case of standard gasket (EPDM rubber), tighten the adapter mounting screw according to the torque values in Table 3.3.18.
- In case that optional code GH (Silicon rubber) is selected, tighten the adapter mounting screw according to the torque values in Table 3.3.19.
- Tighten the adapter mounting screw in diagonal order step by step.
- After tightening of screw, confirm that gaskets protrude inside adapter. Protruding of gasket is necessary to keep the sanitary requirements.

Table 3.3.18 Tightening Torque Values of adapter for EPDM rubber gasket

Tightening torque values (N-m / {kgf-cm} / [in-lbf])	
Gasket type	EPDM rubber (standard)
Size mm (inch)	
15 (0.5), 25 (1.0), 32 (1.25), 40 (1.5)	3.0 to 3.5 / {30.59 to 35.69} / [26.55 to 30.98]
50 (2.0), 65 (2.5)	4.5 to 5.0 / {45.89 to 50.99} / [39.83 to 44.25]
80 (3.0)	8.0 to 9.0 / {81.58 to 91.78} / [70.81 to 79.65]
100 (4.0), 125 (5.0)	10 to 11 / {102.0 to 112.2} / [88.50 to 97.35]

T0502.EPS

Table 3.3.19 Tightening Torque Values of adapter for silicon rubber gasket

Tightening torque values (N-m / {kgf-cm} / [in-lbf])	
Gasket type	Silicon rubber (optional code GH)
Size mm (inch)	
15 (0.5), 25 (1.0), 32 (1.25), 40 (1.5)	2.0 to 2.5 / {20.39 to 25.49} / [17.70 to 22.13]
50 (2.0), 65 (2.5), 80 (3.0)	4.0 to 4.5 / {40.79 to 45.89} / [35.40 to 39.83]
100 (4.0), 125 (5.0)	6.0 to 6.5 / {61.18 to 66.28} / [53.10 to 57.53]

T0503.EPS

4) Mounting flowmeter to piping

Connect the flowmeter to the piping in a manner appropriate to the ferrule, the sleeve, or the alternative that has been welded to the adapter.

5) Confirmation of adapter mounting screw

After installation of the magnetic flowmeter, be sure to retighten the adapter mounting screw according to Table 3.3.18 or Table 3.3.19.

Be sure to confirm that leakage from adapter connection point does not occur by filling the pipe of the flowtube with fluid.

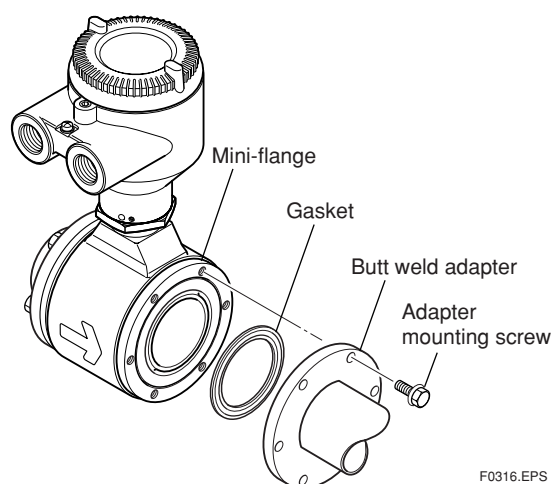

F0316.EPS

Figure 3.3.8 Mounting Procedure for Weld Joint Adapter Type

(3) Maintenance of Sanitary Type

Refer to Section 5.3.

4. WIRING

4.1 Wiring the Integral Flowmeter

This section describes the wiring of the integral flowmeter.



WARNING

The wiring of the magnetic flowmeter must be performed by expert engineer or skilled personnel. No operator shall be permitted to perform procedures relating to wiring.



CAUTION

Once all wiring is complete, check the connections before applying power to the instrument. Improper arrangements or wiring may cause a unit malfunction or damage.

4.1.1 Wiring Precautions

Be sure to observe the following precautions when wiring:



CAUTION

- In cases where the ambient temperature exceeds 50°C (122°F), use external heat-resistant wiring with a maximum allowable temperature of 70°C (158°F) or above.
- Do not connect cables outdoors in wet weather in order to prevent damage from condensation and to protect the insulation, e.g. inside the terminal box of the flowmeter.
- All the cable ends must be provided with round crimp-on terminals and be securely wired.
- The signal cables must be routed in separate steel conduit tubes 16 (JIS C 8305) or flexible conduit tubes 15 (JIS C 8309).
- Always route the power and output signal cables in separate steel conduit tubes, except when the power supply voltage is 24V and four-core cables are used for wiring. Keep conduits or flexible tubes watertight using sealing tape.

- When waterproof glands or union equipped waterproof glands are used, avoid tightening the glands with an excessive torque.
- When the power supply voltage is 24V, it comes with a blanking plug. Use this plug to cover the unused wiring port when wiring the instrument with only one, four-core cable.
- Be sure to turn the power off before opening the terminal box cover.
- Before turning the power on, tighten the terminal box cover securely.
- The terminal box cover is locked by the special screw. In case of opening the terminal box cover, use the hexagonal wrench attached. For handling the locking screw, refer to Figure 4.1.5.
- Be sure to lock the cover by the special screw using the hexagonal wrench attached after installing the cover. For handling the locking screw, refer to Figure 4.1.15.
- Explosion protected types must be wired in accordance with specific requirement (and, in certain countries, legal regulations) in order to preserve the effectiveness of their explosion protected features.

4.1.2 Power Cable/Output Cable

JIS C 3401 control cable equivalent

JIS C 3312 power cable equivalent

14 AWG Belden 8720 equivalent

Outer Diameter:

With no gland option:

6.5 to 12 mm (0.26 to 0.47 in.)

With gland options EG, EU:

10.5 or 11.5 mm (0.41 to 0.45 in.)

With gland options EP:

6 to 12 mm (0.24 to 0.47 in.)

Nominal Cross Section:

Single wire; 0.5 to 2.5 mm²

Stranded wire; 0.5 to 1.5 mm²

In case of power cable, Green/Yellow covered conductor shall be used only for connection to PROTECTIVE CONDUCTOR TERMINALS. Conform to IEC227, IEC245 or equivalent national authorization.

**NOTE**

- For power cables, always use a crimp terminal with an insulation cover.
- Use crimp tools from the manufacturer of the crimp terminal you want to use to connect the crimp terminal and cable.
- Use crimp tools that are appropriate for the diameter of the cable to be connected.

4.1.3 Wiring Ports

This instrument is of watertight construction as stipulated in JIS C 0920. It is shipped with a wiring bracket (waterproof gland or waterproof gland with union) or a plastic gland attached, only in cases where an optional specification is selected for the wiring port. In case of the explosion proof type, refer to Chapter 8.

**IMPORTANT**

The wiring port is sealed with a cap (not waterproof). Do not remove the cap from the unused wiring port. If waterproof property is necessary, apply a blanking plug to the unused wiring port. The blanking plug may not be attached depending on the specification. If it is necessary, contact YOKOGAWA.

(1) When waterproof property is unnecessary (When there are no particular optional specifications)

The wiring port is sealed with a cap (not water-proof) that must be removed before wiring. At this time, handle the wiring port in accordance with the JIS C 0920 mentioned above. Do not remove the cap from the unused wiring port.

(2) When waterproof property is necessary (Wiring using waterproof glands)

**IMPORTANT**

To prevent water or condensation from entering the converter housing, waterproof glands are recommended. Do not over-tighten the glands or damage to the cables may result. Tightness of the gland can be checked by confirming that the cable is held firmly in place.

For working on the electric wire tubes or the flexible tubes (G1/2), remove the waterproof gland and attach them directly to the wiring port.

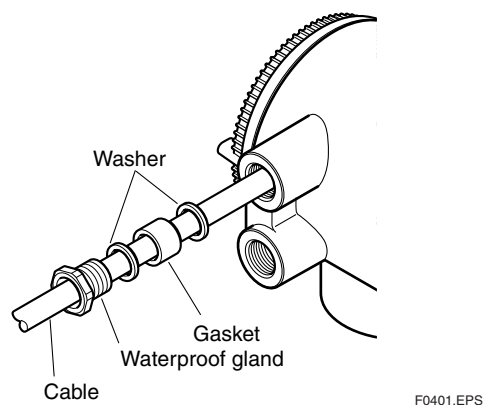

Figure 4.1.1 Waterproof Gland (Optional code EG)

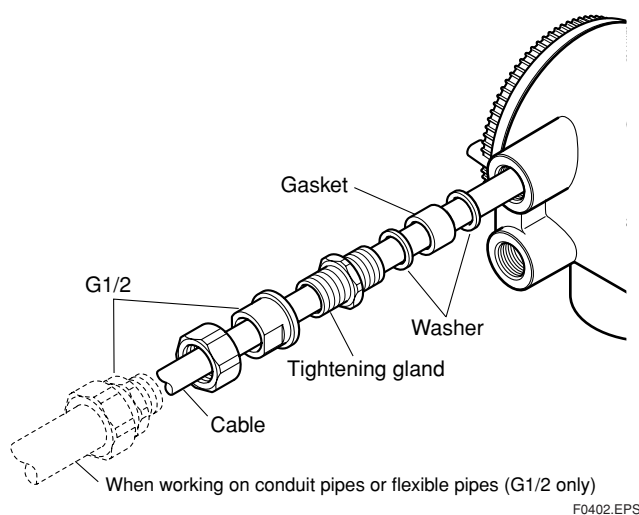

Figure 4.1.2 Waterproof Gland with Union Joint (Optional code EU)

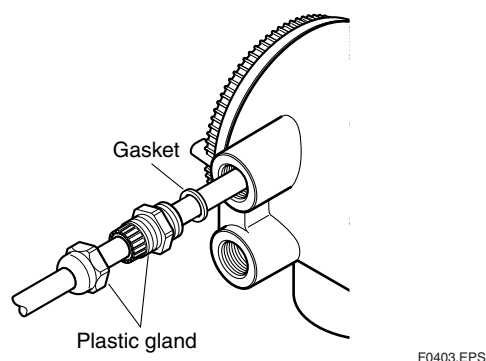

Figure 4.1.3 Plastic Gland (Optional code EP)

(3) Conduit Wiring

When wiring the conduits, pass the conduit through the wiring connection port, and utilize the waterproof gland to prevent water from flowing in. Place the conduit pipe on an angle as shown in Figure 4.1.4. Install a drain valve at the low end of the vertical pipe, and open the valve regularly.

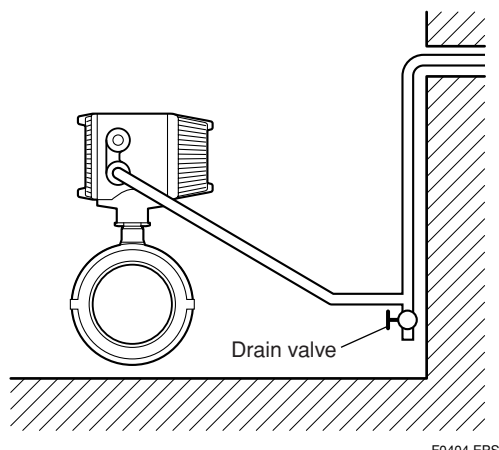

Figure 4.1.4 Conduit Wiring

4.1.4 Wiring Connections

(1) Removing Cover

Loosen cover locking screw 2 clockwise using a hexagonal wrench (nominal size 3) to unlock the cover. (Upon shipment from the manufacturing plant, the cover is unlocked.) Hold the flowmeter with your hand and remove the cover by turning it in the direction of the arrow as shown below.

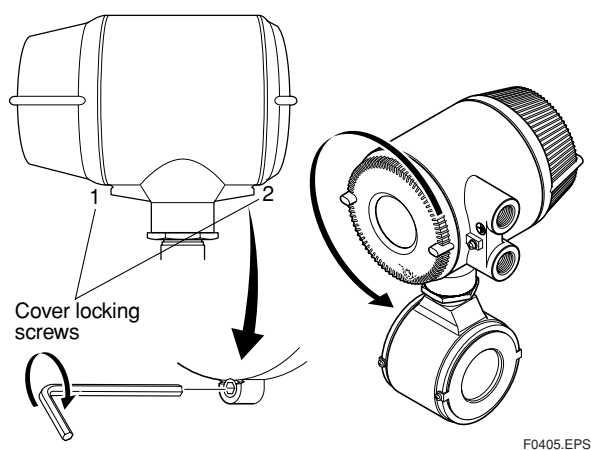

Figure 4.1.5 Removing the Terminal Box Cover

(2) Terminal Configuration

When the cover is removed, the connection terminals will be visible.

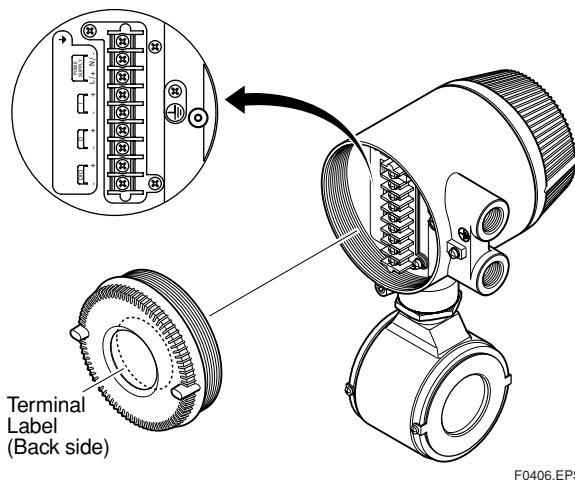

Figure 4.1.6 Terminal Configuration

The description of the terminal symbols is shown in Table 4.1.1.

For FOUNDATION Fieldbus protocol, please refer to IM 01E20F02-01E.

For PROFIBUS PA protocol, please refer to IM 01E20F12-01E.

Table 4.1.1 Terminal Symbols

Terminal Symbols	Description
	Functional grounding
N/- L/+	Power supply
I+ I-	
DO+ DO-	Pulse output/Alarm output/ Status output
DIO+ DIO-	Alarm output/Status output Status input
	Protective grounding (Outside of the terminal)

T0401.EPS

(3) Precautions for Wiring of Power Supply Cables

When connecting to the power supply, observe the points below. Failure to comply with these warnings may result in an electric shock or damage to the instrument.

! WARNING

- Ensure that the power supply is OFF in order to prevent electric shocks.
- Ensure the protective grounding terminal is grounded before turning the power on.
- Use insulating sleeve crimp terminals (for 4-mm screws) for the power supply wiring and protective grounding wiring.
- Install an external switch or circuit breaker as a means to turn the power off (capacitance; 15A, conforming to IEC60947-1 and IEC60947-3). Locate this switch either near the instrument or in other places facilitating easy operation. Affix a "Power Off Equipment" label to this external switch or circuit breaker.

Wiring Procedure

1. Turn the instrument's power off.
2. Wire the power supply cable and the functional grounding cable to the power supply terminals.

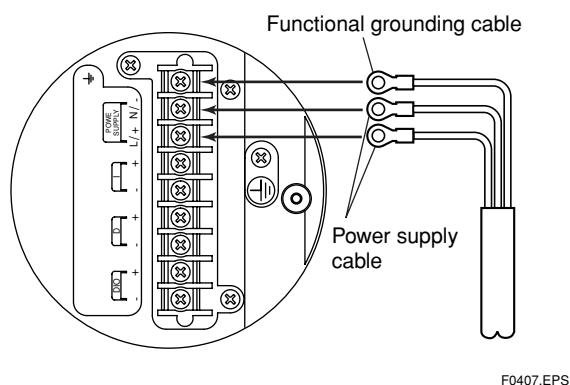

Figure 4.1.7 Electric Cable Wiring

(4) DC Power Connection

When using DC power as the power supply for the converter, give attention to the following points.

1) Connecting Power Supply

! IMPORTANT

Do not connect power supply with reversed polarities.

- L/+ terminal: connect +
- N/- terminal: connect -

! IMPORTANT

Do not connect power supply with 100 to 240 V AC or 100 to 120 V DC in the case of a 24 V power supply version (power supply code 2). It will give a damage to the converter.

2) Required Power Supply Voltages

! IMPORTANT

When using a 24 V power supply, the specification for the supply voltage is 24 V (-15% to +20%), but the input voltage of the converter drops due to cable resistance therefore it must be used within the following ranges.

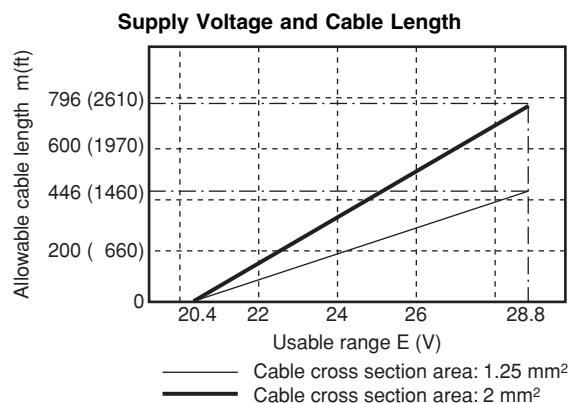

3) Setting Power Supply Frequency

! IMPORTANT

Set the local commercial power frequency in order to eliminate the effect of induction noise from the power supply.

Refer to "Chapter 6: Parameter Description" in the user's manual of the AXF Integral Flowmeter [Software Edition] (IM 01E20C02-01E).

Parameter No.: **J30** and **J31**

(5) Grounding

! CAUTION

Be sure to connect the protective grounding of the AXF integral flowmeter with a cable of 2mm² or larger cross section in order to avoid electrical shock to the operators and maintenance engineers and to prevent the influence of external noise.

Connect the grounding wire to the \oplus mark.

The grounding should satisfy Class D requirements (ground resistance, 100 Ω or less).

In case of TIIS Flameproof type, the grounding should satisfy Class C requirements (ground resistance, 10 Ω or less) or class A requirements (ground resistance, 10 Ω or less).

For explosion proof type except TIIS, follow the domestic electrical requirements as regulated in each country.

**IMPORTANT**

When optional code A (lighting protector) is selected, the ground should satisfy Class C requirements (grounding resistance, 10 Ω or less).

- The protective grounding terminals  are located on the inside and outside of the terminal area. Either terminal may be used.
- Use 600 V vinyl insulation wires as the grounding wires.

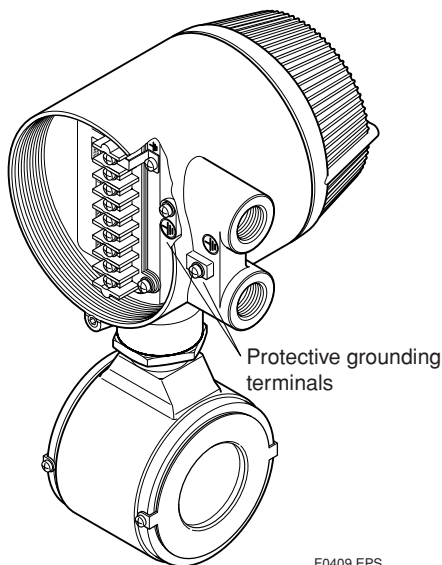

F0409.EPS

Figure 4.1.8 Protective Grounding Terminal Location

**IMPORTANT**

Improper grounding can have an adverse effect on the flow measurement. Ensure that the instrument is properly grounded.

The electromotive force of the magnetic flowmeter is minute and it is easily affected by noise, and the reference electric potential is the same as that of the measuring fluid. Therefore, the reference electric potential (terminal potential) of the flowtube and converter also need to be the same as that of the measuring fluid. Moreover, the potential must be the same as the ground. The magnetic flowmeter is equipped with an grounding ring that makes a connection with the charge of the measured fluid for grounding and protects the lining. Be sure to ground the flowmeter according to Figure 4.1.9.

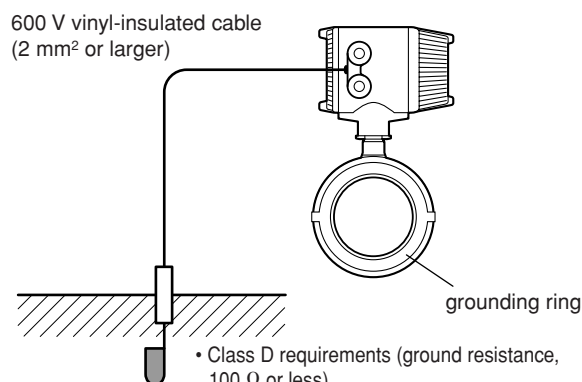

- Class D requirements (ground resistance, 100 Ω or less).
- Optional code A (lighting protector): Class C requirements (ground resistance, 10 Ω or less).
- TIIIS Flameproof type: Class C requirements (ground resistance, 10 Ω or less) or class A requirements (ground resistance, 10 Ω or less).
- Explosion proof type except TIIIS: Domestic electrical requirements as regulated in each country.

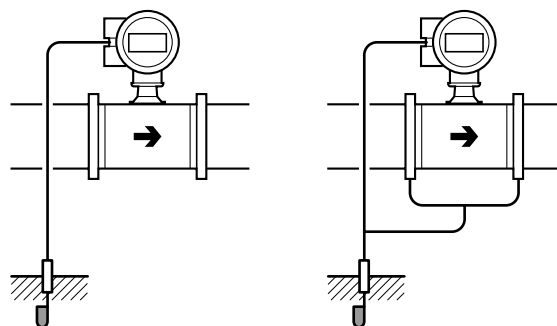

In case grounding rings are used.

In case grounding rings are not used.
(Available only for metal piping)

F0410.EPS

Figure 4.1.9 Grounding

(6) Connecting to External Instruments**WARNING**

Before wiring with external instruments, be sure to turn off the magnetic flowmeter and any external instruments.

Connect the AXF integral flowmeter terminal to external instruments, giving attention to the following points. For FOUNDATION Fieldbus protocol, please refer to IM 01E20F02-01E. For PROFIBUS PA protocol, please refer to IM 01E20F12-01E.

● 4 to 20 mA DC Current Output

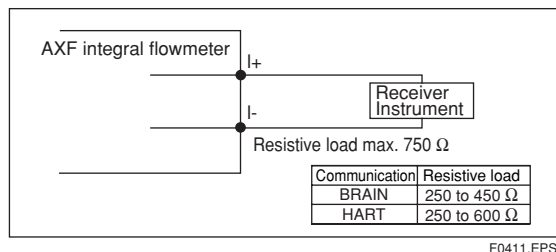

F0411.EPS

Figure 4.1.10 4 to 20 mA DC Output Connection

● Pulse Output



IMPORTANT

- As this is a transistor contact (insulated type), give attention to proper voltage and polarity when wiring.
- Do not apply a voltage larger than 30V DC or a current larger than 0.2A in order to prevent damage to the instrument.
- When input filter constant of the electronic counter is large in relation to the pulse width, the signal will decrease and the count will not be accurate.
- If the input impedance of the electronic counter is large, an induction noise from the power supply may result in inaccurate counts. Use a shield cable or sufficiently reduce the input impedance of the electronic counter within the magnetic flowmeter pulse output specification range.
- The active pulse output (Optional code EM) cannot be used in conjunction with the standard pulse output.
- When the active pulse output (Optional code EM) is selected, do not be short-circuit between the DO+ and DO- terminals to avoid damaging the instrument.
- When the active pulse output (Optional code EM) is selected, the range of pulse rate must be set to 2 pps maximum.
- To avoid communication (BRAIN/ HART) failure, it is recommended to use the shield cable.



NOTE

For pulse output from the DO terminals, parameters must be set. Refer to “Parameter Description” in the user’s manual of the AXF Integral Flowmeter [Software Edition] (IM 01E20C02-01E).

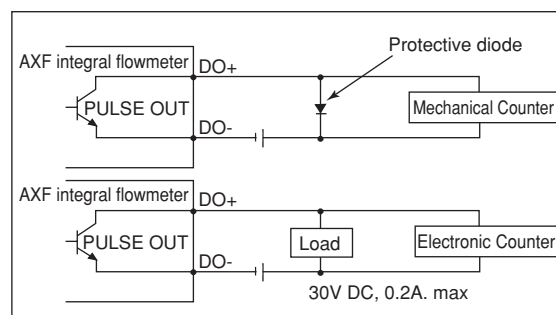

F0412.EPS

Figure 4.1.11 Pulse Output Connection

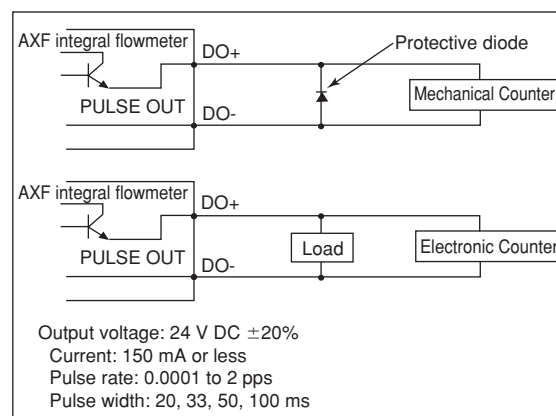

F0413.EPS

Figure 4.1.12 Active Pulse Output Connection (Optional code EM)

● Status Input

IMPORTANT

Status inputs are designed for use with no-voltage (dry) contacts. Be careful not to connect the status to any signal source carrying voltage. Applying voltage may damage the input circuit.

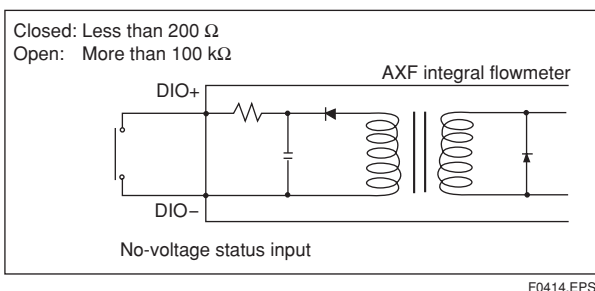

Figure 4.1.13 Status Input Connection

NOTE

For status input to the DIO terminals, parameters must be set. Refer to “Parameter Description” in the user’s manual of the AXF Integral Flowmeter [Software Edition] (IM 01E20C02-01E).

● Status Output / Alarm Output

IMPORTANT

Since this is an isolated transistor output, be careful of voltage and polarity when wiring. Do not apply a voltage larger than 30V DC or a current larger than 0.2A in order to prevent damage to the instrument.

This output cannot switch an AC load. To switch an AC load, an intermediate relay must be inserted as shown in Figure 4.1.14.

*The alarm output operates from open (normal) to closed (alarm occurrence) in the default value (as setup upon plant shipment). Changes can be made via the parameter settings.

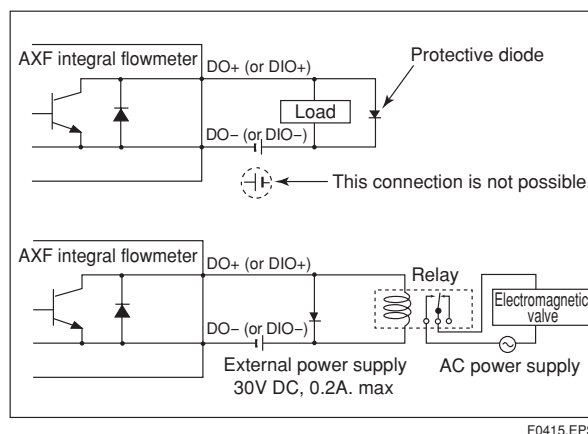

Figure 4.1.14 Status Output/Alarm Output Connection

NOTE

For status and alarm outputs from the DO or DIO terminals, parameters must be set. Refer to “Parameter Description” in the user’s manual of the AXF Integral Flowmeter [Software Edition] (IM 01E20C02-01E).

(7) Installing the Cover

Install the cover to the flowmeter by turning it in the direction of the arrow as shown below. Tighten cover locking screw 2 counterclockwise using a hexagonal wrench (nominal size 3) to lock the cover.

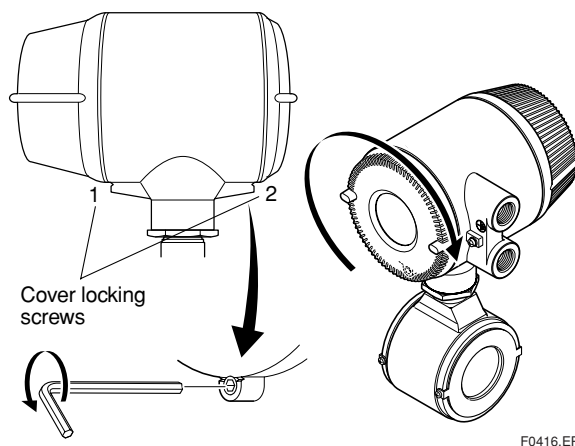

Figure 4.1.15 Installing the Terminal Box Cover

4.2 Wiring the Remote Flowtube

This section describes the wiring of the remote flowtube only. For information relating to the wiring of the converter, refer to the user's manual of the AXFA11 Magnetic Flowmeter Remote Converter (IM 01E20C01-01E) or the AXFA14 Magnetic Flowmeter Remote Converter (IM 01E20C02-01E).

WARNING

The wiring of the magnetic flowmeter must be performed by expert engineer or skilled personnel. No operator shall be permitted to perform procedures relating to wiring.

CAUTION

Once all wiring is complete, check the connections before applying power to the instrument. Improper arrangements or wiring may cause a unit malfunction or damage.

4.2.1 Wiring Precautions

Be sure to observe the following precautions when wiring:

CAUTION

- In cases where the ambient temperature exceeds 50°C (122°F), use external heat-resistant wiring with a maximum allowable temperature of 70°C (158°F) or above.
- Do not connect cables outdoors in wet weather in order to prevent damage from condensation and to protect the insulation, e.g. inside the terminal box of the flowtube.
- Do not splice the cable between the flowtube terminal and the converter if it is too short. Replace the short cable with a cable that is the appropriate length.
- All the cable ends must be provided with round crimp-on terminals and be securely wired.
- The signal cables must be routed in separate steel conduit tubes 16 (JIS C 8305) or flexible conduit tubes 15 (JIS C 8309).
- Keep conduits or flexible tubes watertight using sealing tape.

- Ground the remote flowtube and the converter separately.
- Cover each shield of the signal cable with vinyl tube or vinyl tape to avoid contact between two shields or between a shield and a case.
- When waterproof glands or union equipped waterproof glands are used, avoid tightening the glands with an excessive torque.
- Be sure to turn the power off before opening the terminal box cover.
- Before turning the power on, tighten the terminal box cover securely.
- The terminal box cover is locked by the special screw. In case of opening the terminal box cover, use the hexagonal wrench attached. For handling the locking screw, refer to Figure 4.2.8.
- Be sure to lock the cover by the special screw using the hexagonal wrench attached after installing the cover. For handling the locking screw, refer to Figure 4.2.16.
- Explosion protected types must be wired in accordance with specific requirement (and, in certain countries, legal regulations) in order to preserve the effectiveness of their explosion protected features.
- When submersible type or optional code DHC is selected, waterproof glands, signal and excitation cables are attached. In order to preserve the effectiveness of waterproof features, the terminal box cover and waterproof glands must not be detached from flowmeter.

IMPORTANT

Prepare the signal cable and the excitation cable almost the same length. It is recommended to lay them together closely.

4.2.2 Cables

(1) Dedicated Signal Cable (AXFC)

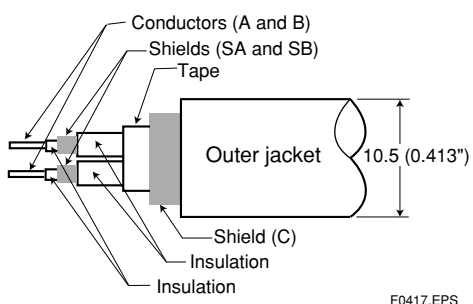

F0417.EPS

Figure 4.2.1 Dedicated Signal Cable AXFC

The flow signal is transmitted via this dedicated cable. The cable is constructed with double shielding over the two conductors, and heat-resistant vinyl is used for the outer jacket material.

Finished diameter: 10.5 mm (0.413")

Maximum length:

Combination with the AXFA11 converter:
200 m (660 ft)

Combination with the AXFA14 converter:
100 m (330 ft)

Maximum temperature: 80°C (176°F)



IMPORTANT

If the cable is longer than required, cut off any extra length rather than coiling it up, and terminate the conductors as shown in Figure 4.2.2. Avoid using junction terminal boards to extend the cable length, as this will interrupt the shielding.

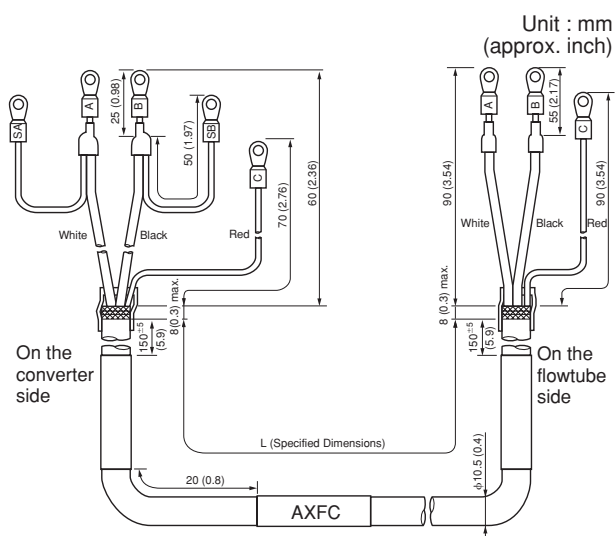

F0418.EPS

Figure 4.2.2 Treatment of Dedicated Signal Cables



CAUTION

- As crimp terminals A, B, SA, SB and C have their own electrical potentials, securely insulate them so as not to come in contact with one another.
- To prevent a shield from coming in contact with another shield or the case, cover each shield with a vinyl tube or wrap it in vinyl tape.



NOTE

Conductors A and B carry the signal from the electrodes, and C is at the potential of the liquid (signal common). Shields SA and SB are kept at the same potentials as the individual electrodes (these are actively driven shields). This is done to reduce the effect of the distributed capacitance of the cable at long cable length. Note that, since the signals from the individual electrodes are impedance converted inside the converter, errors will result if they come in contact with any other component. Great care must be taken in the cable end treatment.

(2) Excitation Cable

JIS C 3401 control cable equivalent

JIS C 3312 power cable equivalent

14 AWG Belder 8720 equivalent

Outer Diameter:

With no gland option:

6.5 to 12 mm (0.26 to 0.47 in.)

With gland options EG, EU and EW:

10.5 or 11.5 mm (0.41 to 0.45 in.)

With gland options EP:

6 to 12 mm (0.24 to 0.47 in.)

Nominal Cross Section:

Single wire; 0.5 to 2.5 mm²

Stranded wire; 0.5 to 1.5 mm²

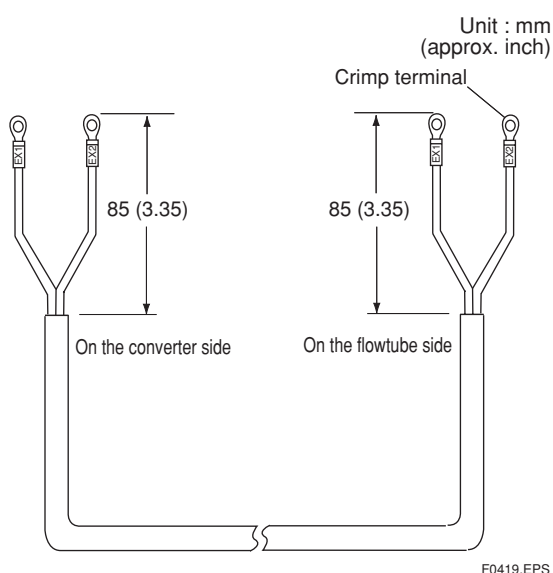

Figure 4.2.3 End Treatment of Excitation Cable



NOTE

- For excitation cables, always use a crimp terminal with an insulation cover.
- Use crimp tools from the manufacturer of the crimp terminal you want to use to connect the crimp terminal and cable.
- Use crimp tools that are appropriate for the diameter of the cable to be connected.

4.2.3 Wiring Ports

This instrument is of watertight construction as stipulated in JIS C 0920. It is shipped with a wiring bracket (waterproof gland or waterproof gland with union) or a plastic gland attached, only in cases where an optional specification is selected for the wiring port. In case of the explosion proof type, refer to Chapter 8.



IMPORTANT

The wiring port is sealed with a cap (not waterproof). Do not remove the cap from the unused wiring port. If waterproof property is necessary apply a blanking plug to the unused wiring port. The blanking plug may not be attached depending on the specification. If it is necessary, contact YOKOGAWA.

(1) When waterproof property is unnecessary (When there are no particular optional specifications)

The wiring port is sealed with a cap (not water-proof) that must be removed before wiring. At this time, handle the wiring port in accordance with the JIS C 0920 mentioned above. Do not remove the cap from the unused wiring port.

(2) When waterproof property is necessary (Wiring using waterproof glands)



IMPORTANT

To prevent water or condensation from entering the converter housing, waterproof glands are recommended. Do not over-tighten the glands or damage to the cables may result. Tightness of the gland can be checked by confirming that the cable is held firmly in place.

For working on the electric wire tubes or the flexible tubes (G1/2), remove the waterproof gland and attach them directly to the wiring port.

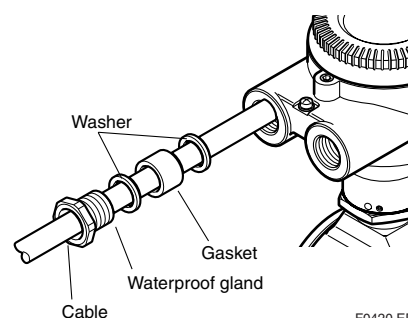
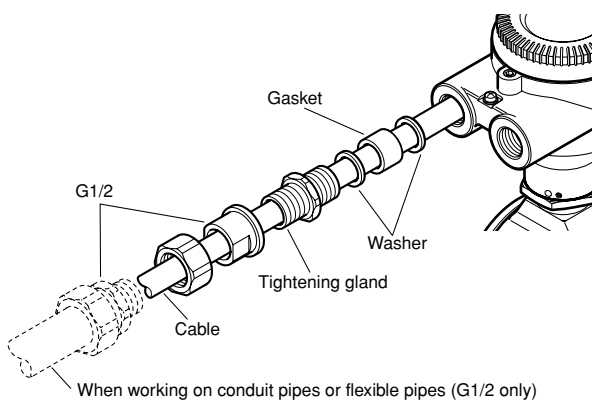

Figure 4.2.4 Waterproof Gland (Optional code EG)

4.2.4 Wiring Connections

WARNING

Before wiring, be sure that the power supply for AXFA11 or AXFA14 converter has been turned off to prevent an electrical shock.



F0421.EPS

Figure 4.2.5 Waterproof Gland with Union Joint (Optional code EU)

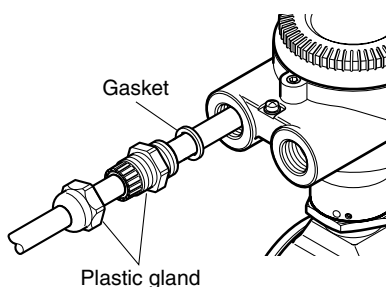

F0422.EPS

Figure 4.2.6 Plastic Gland (Optional code EP)

(3) Conduit Wiring

When wiring the conduits, pass the conduit through the wiring connection port, and utilize the waterproof gland to prevent water from flowing in. Place the conduit pipe on an angle as shown in Figure 4.2.7. Install a drain valve at the low end of the vertical pipe, and open the valve regularly.

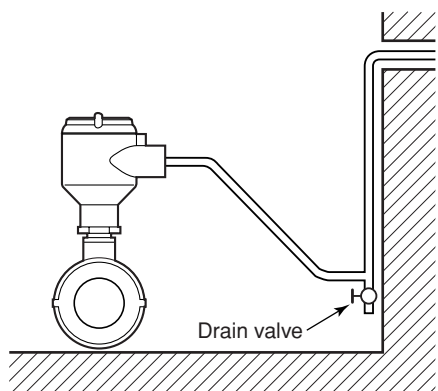

F0423.EPS

Figure 4.2.7 Conduit Wiring

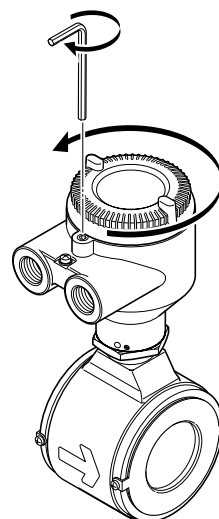

F0424.EPS

Figure 4.2.8 Removing the Terminal Box Cover (Remote Flowtube)

(2) Terminal Configuration

When the cover is removed, the connection terminals will be visible.

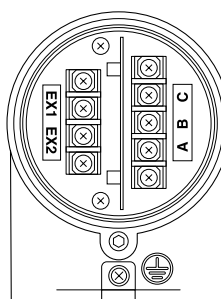

Terminal Symbols	Description
A B C	Flow signal output
EX1 EX2	Excitation current input
⊕	Protective grounding (Outside of the terminal)

F0425.EPS

Figure 4.2.9 Terminal Configuration (General-Purpose Use, Submersible Type, Sanitary Type)

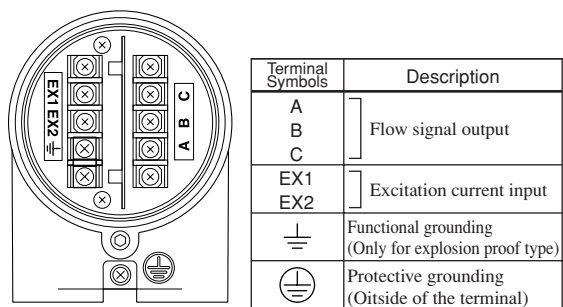

F042401.EPS

Figure 4.2.10 Terminal Configuration (Explosion proof Type)

(3) Wiring the Remote Flowtube (General-Purpose Use, Submersible Type, Sanitary Type with Converters)

1) Connection with the AXFA11 converter

Connect wiring as shown in the figure below.

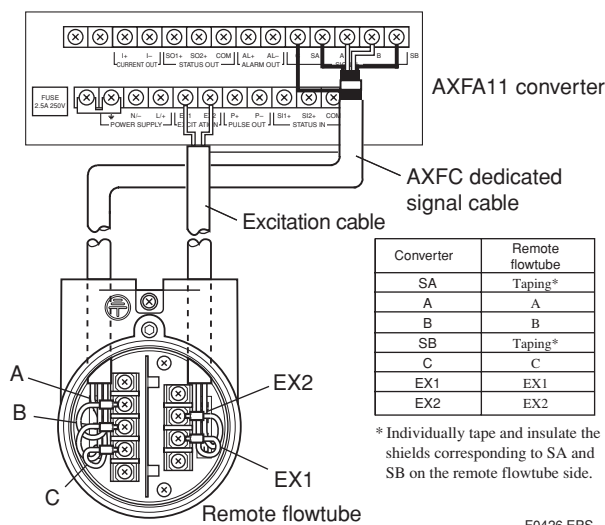

F0426.EPS

Figure 4.2.11 Wiring Diagram

2) Connection with the AXFA14 converter

Connect wiring as shown in the figure below.

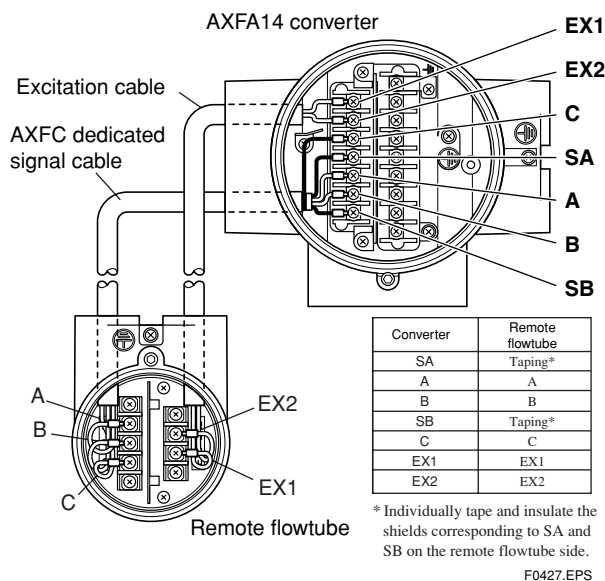

F0427.EPS

Figure 4.2.12 Wiring Diagram

(4) Wiring the Remote Flowtube (Explosion Proof Type) with Converters

IMPORTANT

In case of ATEX, IECEx, or TIIS certified AXF remote flowtube, it is only approved to be combined with AXFA14 converter.

1) Connection with the AXFA11 converter

In case of FM or CSA certified AXF remote flowtube, connect wiring as shown in the figure below.

In case of the explosion proof type, the protective grounding ⊕ of remote flowtube must be connected to a suitable IS grounding system. In that case, ⊥ (functional grounding terminal) need not be connected.

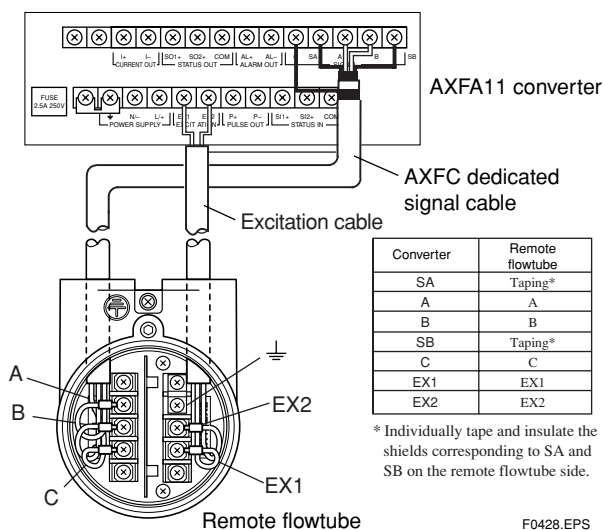

Figure 4.2.13 Wiring Diagram

2) Connection with the AXFA14 converter

In case of ATEX, FM, CSA, IECEx or TIIS certified AXF remote flowtube, connect wiring as shown in the figure below.

In case of the explosion proof type, the protective grounding ⊕ of remote flowtube must be connected to a suitable IS grounding system. In that case, ⊥ (functional grounding terminal) need not be connected.

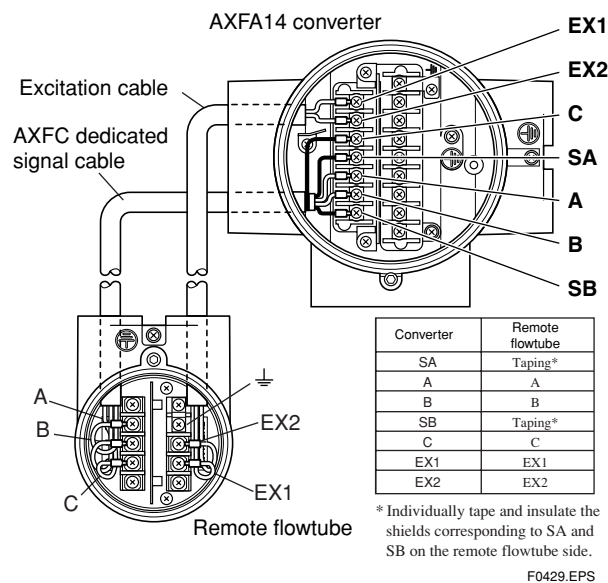

Figure 4.2.14 Wiring Diagram

(5) Grounding**CAUTION**

Be sure to connect the protective grounding of the AXF remote flowtube with a cable of 2mm² or larger cross section in order to avoid electrical shock to the operators and maintenance engineers and to prevent the influence of external noise.

Connect the grounding wire to the \oplus mark.

The grounding should satisfy Class D requirements (ground resistance, 100 Ω or less).

In case of TIIS Flameproof type, the grounding should satisfy Class C requirements (ground resistance, 10 Ω or less) or class A requirements (ground resistance, 10 Ω or less).

For explosion proof type except TIIS, follow the domestic electrical requirements as regulated in each country.

**IMPORTANT**

Improper grounding can have an adverse effect on the flow measurement. Ensure that the instrument is properly grounded.

The electromotive force of the magnetic flowmeter is minute and it is easy to be affected by noise. And also that reference electric potential is the same as the measuring fluid potential. Therefore, the reference electric potential (terminal potential) of the flowtube and the converter also need to be the same as the measuring fluid. Moreover, that the potential must be the same with ground. The magnetic flowmeter is equipped with an grounding ring that makes a connection with the charge of the measured fluid for grounding and protects the lining.

Be sure to ground according to Figure 4.2.15.

600 V vinyl insulated electric cable (2 mm² or larger)

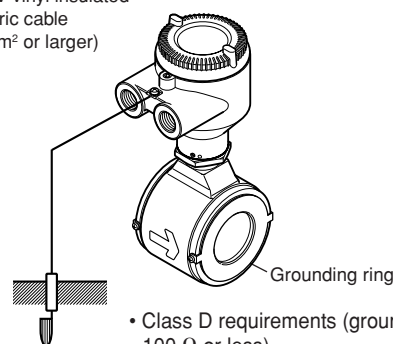

- Class D requirements (ground resistance, 100 Ω or less).
- TIIS Flameproof type: Class C requirements (ground resistance, 10 Ω or less) or Class A requirements (ground resistance, 10 Ω or less)
- Explosion proof type except TIIS: Domestic electrical requirements as regulated in each country.

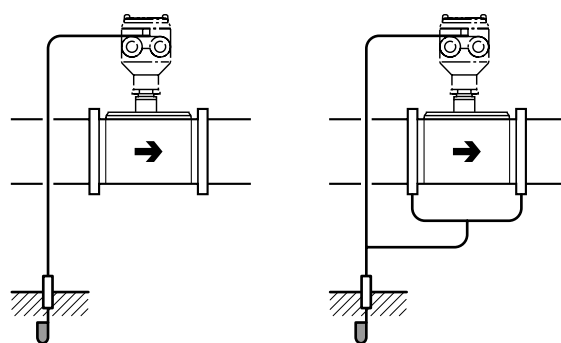

In case grounding rings are used.

In case grounding rings are not used.

(Available only for metal piping)

F0430.EPS

Figure 4.2.15 Protective Grounding Terminal Location

(6) Installing the Cover

Install the cover to the flowtube by turning it in the direction of the arrow as shown below. Tighten the cover locking screw counterclockwise using a hexagonal wrench (nominal size 3) to lock the cover.

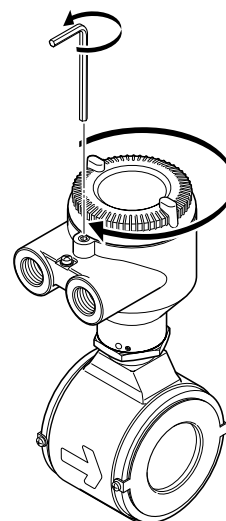

F0431.EPS

Figure 4.2.16 Installing the Terminal Box Cover (Remote Flowtube)

5. MAINTENANCE

WARNING

- Maintenance work must be carried out by the trained personnel having knowledge of safety standard and not by operators.
- When opening the cover, wait for more than 10 minutes after turning off the power. Furthermore, opening of the cover must also be carried out by the trained personnel having knowledge of safety standard.

CAUTION

- Explosion protected type must be, as a rule, removed to a non-hazardous area for maintenance and be disassembled and reassembled to the original state.
- The cover is locked by the special screw. In case of opening the cover, use the hexagonal wrench attached.
- Be sure to lock the cover by the special screw using the hexagonal wrench attached after installing the cover.

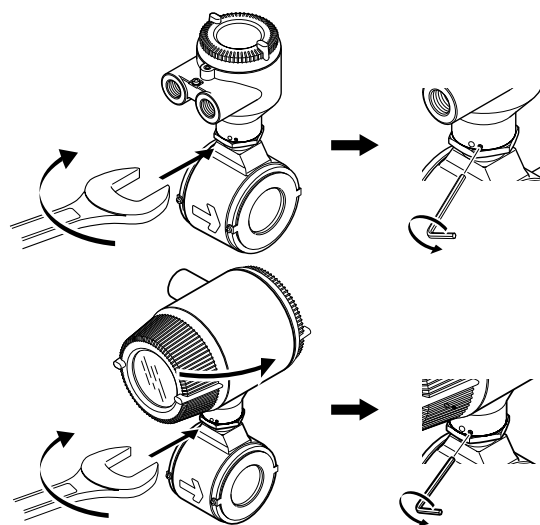

F0501.EPS

- (4) Using the hexagonal wrench, loosen the screw in the neck.
- (5) Turn the converter or the terminal box in the desired direction.

NOTE

The converter and the terminal box can be turned -140 degree to $+180$ degree from the arrow mark indicating the flow direction. Do not exceed these angle.

- (6) Using the hexagonal wrench, retighten the neck screw.

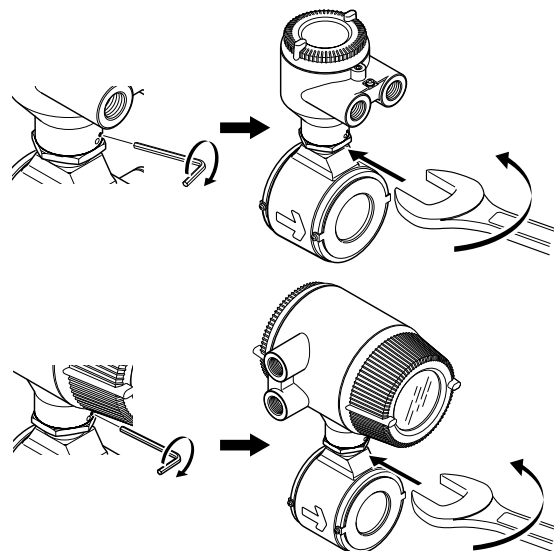

F0502.EPS

- (7) Using the wrench, retighten the hexagonal nut at the neck. After that, check that the converter or terminal box is fixed.

5.1 Changing Direction of Electrical Connection

IMPORTANT

The following types can not be changed direction of electrical connection after delivery.

- Submersible Type.
- Optional code DHC (for district heating and cooling or condensation-proof).

- (1) The following tools are required to change the direction of the electrical connection:
 - Hexagonal wrench (nominal size 1.5): Comes with the instrument.
 - Wrench
- (2) Turn off the power to the flowmeter.
- (3) Using the wrench, loosen the hexagonal nut at the neck of the instrument.

5.2 Removing, Cleaning, and Installing Replaceable Electrodes (General-Purpose Use Type Only)

5.2.1 Removing Replaceable Electrodes

- (1) The following tools are required to replace the electrodes:
- Special tool for removing and installing electrodes (F9807SK): Optional
 - Torque wrench or torque driver (nominal size 12)
 - Phillips screwdriver

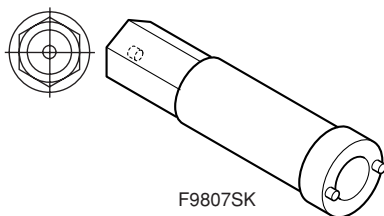

F0503.EPS

- (2) Turn off the power to the flowmeter.
 (3) Drain the fluid from the interior of the flowtube.



WARNING

- Never fail to drain the fluid from the interior of the flowtube.
- If the fluid is at a high temperature, the instrument itself may also be hot. Be careful not to get burned when removing the electrodes.
- When the process fluid is hazardous to humans, exercise caution to avoid coming into contact with it, and avoid inhaling any residual gas.

- (4) Using end A of the tool, open the electrode cover.

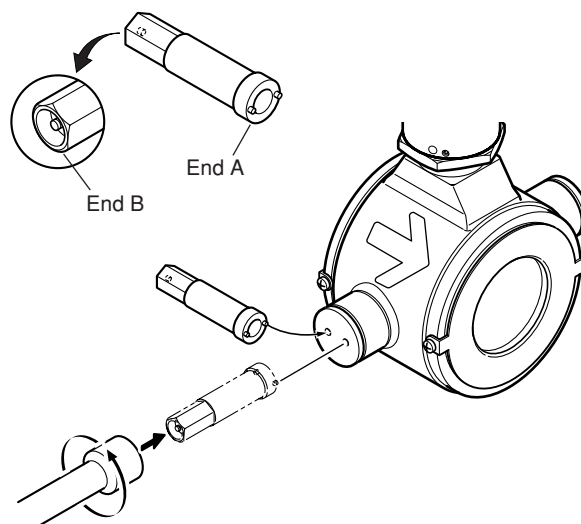

- (5) Hold down the electrode lead wire and terminal lug and remove the mounting screw using the Phillips screwdriver.

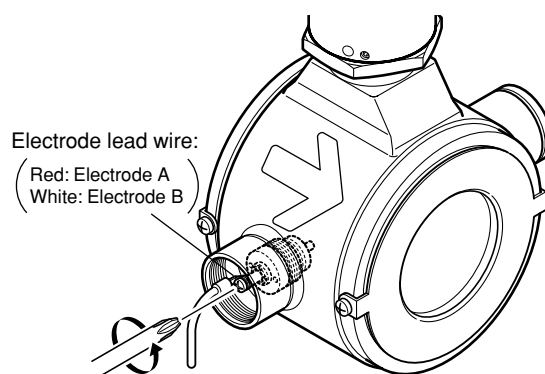

NOTE

Always hold down the lead wire and terminal lug when removing the mounting screw.

- (6) Move aside the electrode lead wire and avoiding the screw, insert end A of the tool to the electrode and loosen the electrode holder using the torque driver.

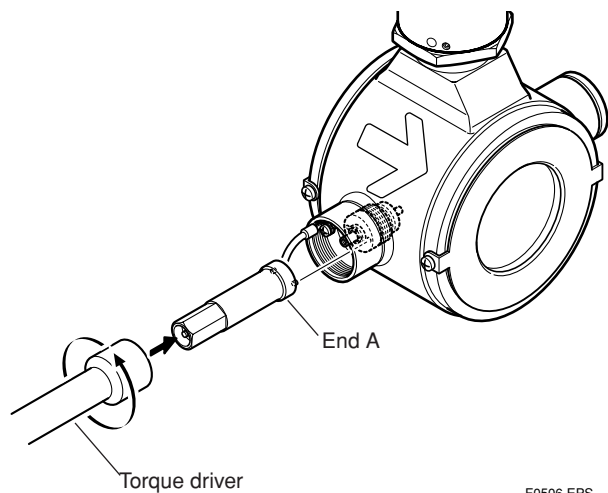

- (7) Screw end B of the tool into the screw block of the electrode, and pull the tool straight out to remove the electrode holder.

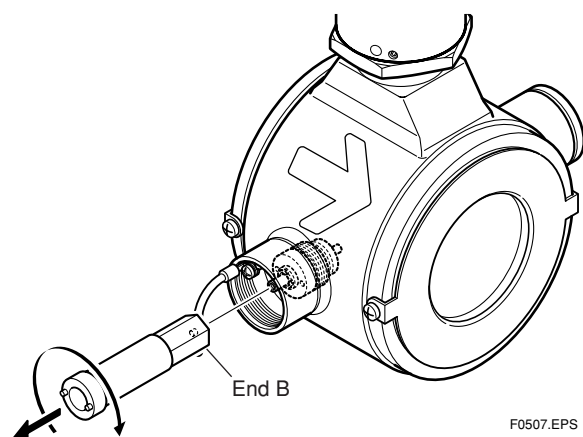

5.2.2 Cleaning Replaceable Electrodes

- (1) Clean the electrode surface (wetted part) with alcohol or other cleaning agents.

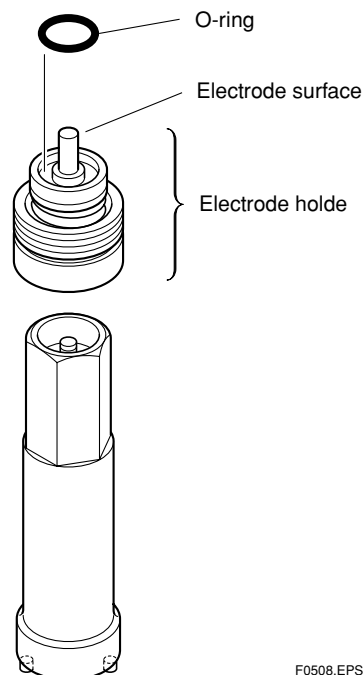

NOTE

The screw threads are coated with an anti-seizing compound. Do not let the compound come in contact with the electrode.

- (2) Clean the surface of the lining seal with an alcohol moistened swab.

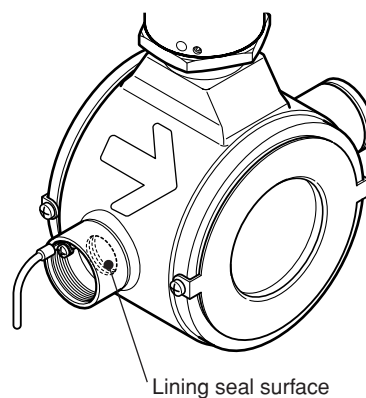

5.2.3 Installing Replaceable Electrodes

NOTE

It is recommended to replace the O-ring when reinstalling the replaceable electrode. Use the O-ring specified by Yokogawa (G9303SE: material is fluororubber).

NOTE

Precautions for storage of O-rings:

- Keep them in a cool, dark place.
- Wrap them well.
- Do not use O-rings after one year since their purchase.

- (1) Push the electrode holder with end B of the tool screwed into it, straight into the flowtube.

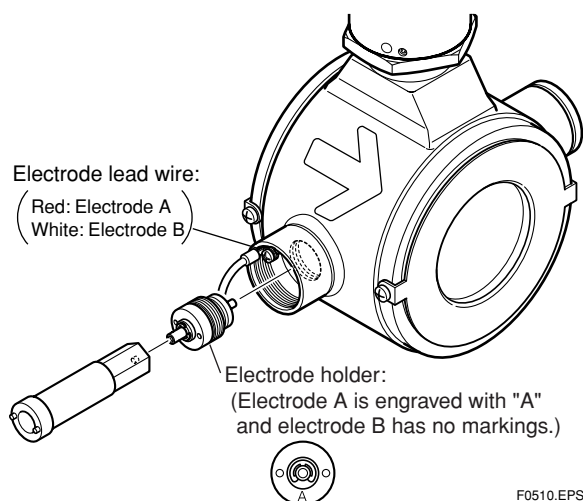

NOTE

- Check that the O-ring has not come off.
- Do not interchange electrodes A and B when installing them. Install electrode A to the electrode boss with the red lead wire and electrode B to the one with the white lead wire.

- (2) Using end A of the tool, tighten the electrode holder.

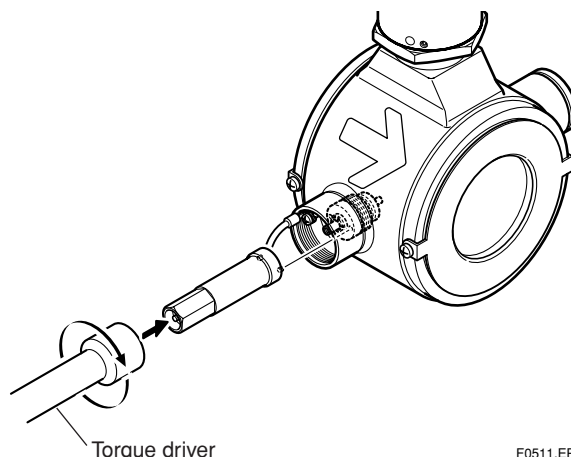

NOTE

Using the torque wrench or torque driver, tighten the electrode holder to the following torque values:

PFA lining:

8.0 N·m ±1 N·m (80 kgf·cm ±10 kgf·cm)

Polyurethane rubber lining:

3.0 N·m ±0.5 N·m (30 kgf·cm ±5 kgf·cm)

WARNING

If the electrode holder was not tightened to its specified torque value, fluid leakage from the electrode may result. Should fluid spill over the electrode block, wipe it dry and check that the O-ring has not come off.

- (3) Fill the interior of the flowtube with the fluid and check that there is no leakage from the electrode.
- (4) Hold down the lead wire and terminal lug and screw the mounting screw into the electrode using the Phillips screwdriver.

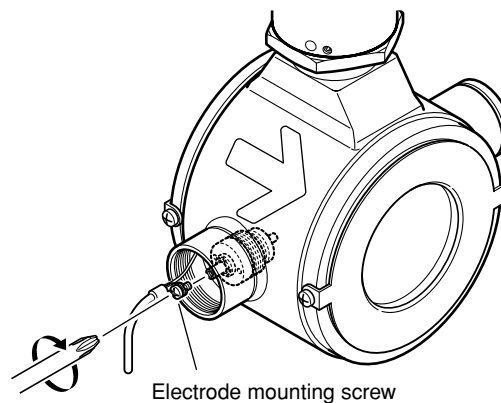

NOTE

Always hold down the lead wire and terminal lug when adjusting the mounting screw.

- (5) Put the lead wire in the electrode boss, and install the electrode cover to the boss and tighten it using end A of the tool.

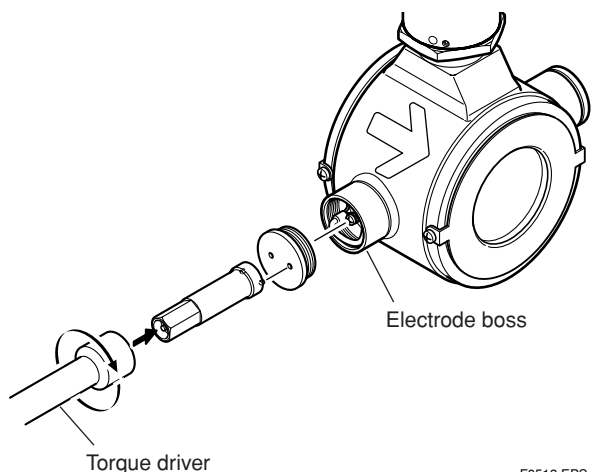

F0513.EPS

- (6) Turn on the power to the flowmeter and start normal operation.

5.3 Removing and Installing Adapters for Sanitary Types

CAUTION

- This section describes how to remove and install a butt weld adapter as an example. Apply the same procedure to clamp and union adapters.
- Turn off the power of the magnetic flowmeter, and confirm that there is no fluid inside the pipe before removing the instrument from the pipe line.
- When installation, refer to Subsection 3.3.6.

1) Removing the butt weld adapter

Remove the butt weld adapter by loosening the mounting screws.

2) Installing the butt weld adapter

Install a gasket to fit in the groove of the butt weld adapter, and tighten in the adapter with the mounting screws.

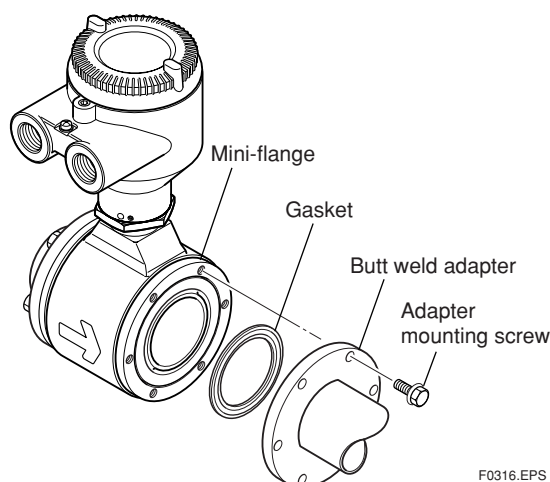

Figure 5.3.1 Removing and Installing a Butt Weld Adapter

CAUTION

- In case of standard gasket (EPDM rubber), tighten the adapter mounting screw according to the torque values in Table 5.3.1.
- In case that optional code GH (Silicon rubber) is selected, tighten the adapter mounting screw according to the torque values in Table 5.3.2.
- Tighten the adapter mounting screw in diagonal order step by step.
- After tightening of screw, confirm that gaskets protrude inside adapter. Protruding of gasket is necessary to keep the sanitary requirements.

Table 5.3.1 Tightening Torque Values of adapter for EPDM rubber gasket

Tightening torque values (N-m / {kgf-cm} / [in-lbf])	
Gasket type	EPDM rubber (standard)
Size mm (inch)	
15 (0.5), 25 (1.0), 32 (1.25), 40 (1.5)	3.0 to 3.5 / {30.59 to 35.69} / [26.55 to 30.98]
50 (2.0), 65 (2.5)	4.5 to 5.0 / {45.89 to 50.99} / [39.83 to 44.25]
80 (3.0)	8.0 to 9.0 / {81.58 to 91.78} / [70.81 to 79.65]
100 (4.0), 125 (5.0)	10 to 11 / {102.0 to 112.2} / [88.50 to 97.35]

T0502.EPS

Table 5.3.2 Tightening Torque Values of adapter for silicon rubber gasket

Tightening torque values (N-m / {kgf-cm} / [in-lbf])	
Gasket type	Silicon rubber (optional code GH)
Size mm (inch)	
15 (0.5), 25 (1.0), 32 (1.25), 40 (1.5)	2.0 to 2.5 / {20.39 to 25.49} / [17.70 to 22.13]
50 (2.0), 65 (2.5), 80 (3.0)	4.0 to 4.5 / {40.79 to 45.89} / [35.40 to 39.83]
100 (4.0), 125 (5.0)	6.0 to 6.5 / {61.18 to 66.28} / [53.10 to 57.53]

T0503.EPS

**CAUTION**

- The lining of sanitary type uses fluorocarbon PFA. For the property of fluorocarbon PFA, it is possible that the adapter mounting screws may loosen as time passes, so retighten them regularly.
- Be sure to retighten the adapter mounting screws according to the prescribed torque values in Table 5.3.1 or Table 5.3.2. Retighten them diagonally with the same torque values, step by step up to the prescribed torque value.
- In case of leakage from adapter connection point, retighten the adapter mounting screws. If leakage doesn't stop even if they are retightened, replace the gasket between mini-flange of flowmeter and adapter.
- It is recommended to replace the gasket periodically,
- It is necessary to decide the period between changes with consideration for the frequency of cleaning cycles, the cleaning temperature and the fluid temperature.
- Use the gasket specified by Yokogawa in Table 5.3.3

Table 5.3.3 Parts number of gasket

Size mm (inch)	Gasket type	
	EPDM rubber (standard)	Silicon rubber (optional code GH)
15 (0.5)	F9811QA	F9811QB
25 (1.0)	B1002EG	B1010EG
32 (1.25)	B1003EG	—
40 (1.5)	B1004EG	B1012EG
50 (2.0)	B1005EG	B1013EG
65 (2.5)	B1006EG	B1014EG
80 (3.0)	B1007EG	B1015EG
100 (4.0)	B1008EG	B1016EG
125 (5.0)	F9811QC	F9811QD

T0504.EPS

5.4 Maintenance for Converter (Integral Flowmeter Only)

WARNING

- Maintenance work must be carried out by the trained personnel having knowledge of safety standard and not by operators.
- When opening the cover, wait for more than 10 minutes after turning off the power. Furthermore, opening of the cover must also be carried out by the trained personnel having knowledge of safety standard.

IMPORTANT

- As a rule, maintenance of this flowmeter should be implemented in a maintenance service shop where the necessary tools are provided.
- The amplifier assembly contains sensitive parts that may be damaged by static electricity. Exercise care so as not to directly touch the electronic parts or circuit patterns on the board, for example, by preventing static electrification by using grounded wrist straps when handling the assembly.

5.4.1 Fuse Replacement

CAUTION

Please contact Yokogawa's service office for fuse replacement. Also be sure to use the fuse that was supplied by Yokogawa's sales or service offices.

5.4.2 Changing the Direction of the Display Unit

(a) Removing the Cover

- (1) Turn off the power.
- (2) Loosen cover locking screw 1 clockwise using a hexagonal wrench (nominal size 3) to unlock the cover. (Upon shipment from the manufacturing plant, the cover is locked.) Hold the flowmeter with your hand and remove the cover by turning it in the direction of the arrow as shown below.

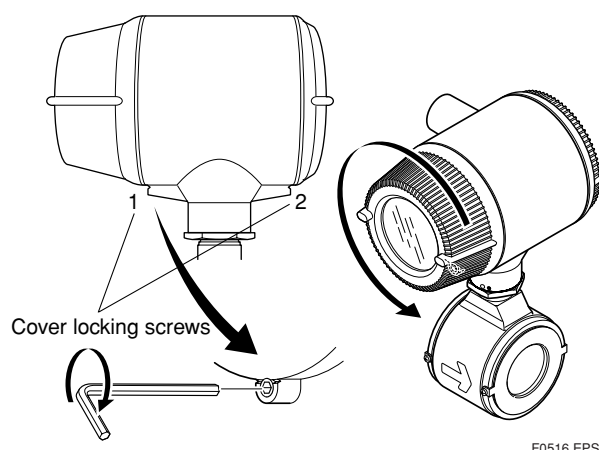

Figure 5.4.1 Removing the Display Cover

(b) Changing the Display Unit Direction 90 Degrees

- (1) Hold the display unit with your hand and remove the two mounting screws.
- (2) Turn the display unit 90 degrees clockwise and confirm the assembling position, taking care of the connector and wire of the display unit. At this time, do not remove the connector.
- (3) Secure the display unit using its two mounting screws.

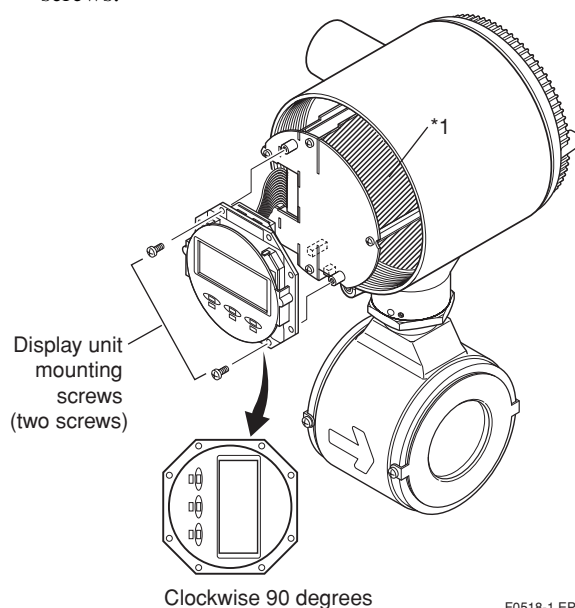

Figure 5.4.2 Changing the Display Unit Direction 90 Degrees

IMPORTANT

*1: To preserve the safety, do not touch the electrical circuit and cable of shaded area.

(c) Installing the Cover

- (1) Taking care not to entangle the cables, install the cover to the flowmeter by turning it in the direction of the arrow as shown below.
- (2) Tighten cover locking screw 1 counterclockwise using a hexagonal wrench (nominal size 3) to lock the cover.

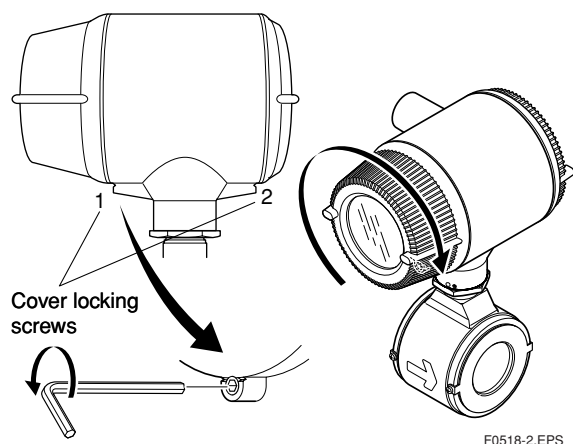

Figure 5.4.3 Installing the Display Cover

5.5 Setting of Switches (Integral Flowmeter Only)

**IMPORTANT**

- Removing and installing cover are necessary for setting switches. Perform removing and installing of the cover as described in Subsection 5.4.2.
- To preserve the safety, do not touch the electrical circuit and the cables except setting switches.

5.5.1 Setting of Burnout Switch

The burnout function sets the direction of current output in situations where the CPU has become damaged. Upon shipment from the manufacturing plant, the burnout direction is set to High (i.e., 25 mA); however, in cases where the optional code C1 has been specified, the output direction will be set to Low (i.e., 0 mA).

Modification of the burnout direction must be carried out using the setting switch from the amplifier's CPU board (i.e., Switch 1) (See Figure 5.5.1).

Table 5.5.1 Output Setting Pins for Burnout

Position of Pin	Burnout Direction	Burnout Output	Remarks
	High	25 mA	Set to High before shipment
	Low	0 mA	Set to Low for optional code C1

T0501.EPS

**NOTE**

- On the amplifier's CPU board, the burnout setting switch (i.e., Switch 1) and the write protect switch (i.e., Switch 2) are located adjacent to each other. Accordingly, special care should be taken when making switch settings.
- In the case of Fieldbus communication type, burnout setting switch is not applied.

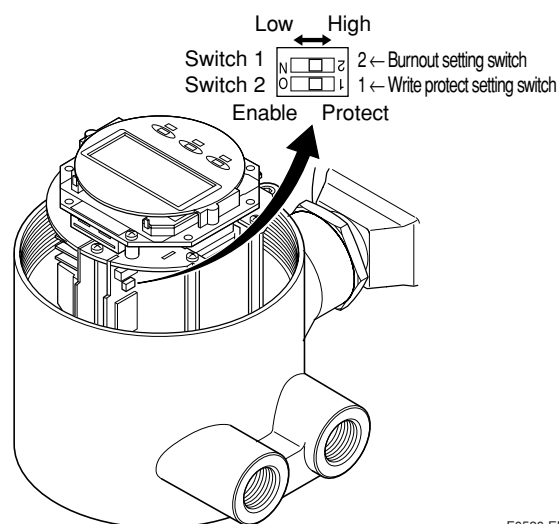

F0520.EPS

Figure 5.5.1 Switch Configuration

5.5.2 Setting of Write Protect Switch

By setting the write protect function to “Protect” it is possible to prevent the overwriting of parameters. Write protection can be carried out using either the hardware switch on the CPU board (i.e., Switch 2) (See Figure 5.5.1) or software parameter settings. If either of these items is set to “Protect,” the overwriting of parameters will be prohibited.

**NOTE**

- If the hardware switch is set to “Protect,” it will not be possible to overwrite parameters; furthermore, this condition will be maintained until the switch is set to “Enable.”
- In the case of Fieldbus communication type, setting of the hardware switch (Enable or Protect) is ineffective and write protection can be carried out only by software parameter settings.

For more details regarding usage of the write protect function and the software’s parameter switches, refer to “Parameter Description” in the user’s manual of the AXF Integral Flowmeter [Software Edition] (IM 01E20C02-01E).

5.6 Regular Inspection Items

- (1) **Inspection of moisture-proofing inside the terminal box: Once/year**
- (2) **Retightening of piping joint screws: About twice/year**
- (3) **Inspection of electrodes and lining (in case of adhesive and/or abrasive fluids, etc.)**

Determine the period of regular inspection as necessary.

5.7 Excitation Coil and Insulation Resistance Check (Remote Flowtube Only)

**WARNING**

- Before checking of the excitation coil and the insulation resistance, be sure that the power supply for AXFA11 or the AXFA14 converter has been turned off.
- Before checking, be sure to disconnect the cables from the terminals of the remote flowtube.

(1) Excitation Coil Check (Remote Flowtube Only)

Check that there is continuity between terminals EX1 and EX2 in the terminal box. If there is no continuity, the coils may be broken and replacement or repair of the flowtube is necessary. The coil resistance is designed to be 150 Ω or less. If it is not, this may be an abnormal condition. Consult Yokogawa’s sales or service offices.

(2) Insulation Resistance Check (Remote Flowtube Only)

Check the insulation resistances in the terminal box in accordance with the tables below. If any of them falls below the values listed in the tables, consult Yokogawa’s sales or service offices for investigation. If the insulation resistance cannot be restored, replacement or repair of the flowtube is needed. In case of submersible type flowmeters, undo the wiring connection on the converter side and measure resistance at the cable terminals.

Coil Circuit

Checking is possible even if the pipe is filled with fluid.

Test Terminals	Test Voltage	Specification
Between terminals EX1 and C	500 V DC (Use an insulation tester or the equivalent.)	1 MΩ or more

T050601.EPS

Signal Circuit

Before testing, be sure to empty and dry the interior of the pipe, checking that there is no adhesive material. Also undo the wiring connection on the converter side before testing.

Test Terminals	Test Voltage	Specification
Between terminals A and C Between terminals B and C	500 V DC (Use an insulation tester or the equivalent.)	100 MΩ or more for each

T050602.EPS

5.8 Maintenance of the LCD Display

**CAUTION**

The LCD display has certain lifespan and it may deteriorate during operation. Please contact Yokogawa office in this case.

5.9 Troubleshooting

Although magnetic flowmeters rarely require maintenance, failures may occur when the instrument is not operated correctly. This section describes troubleshooting procedures where the cause of the breakdown is identified through receiver indication.

5.9.1 No Indication

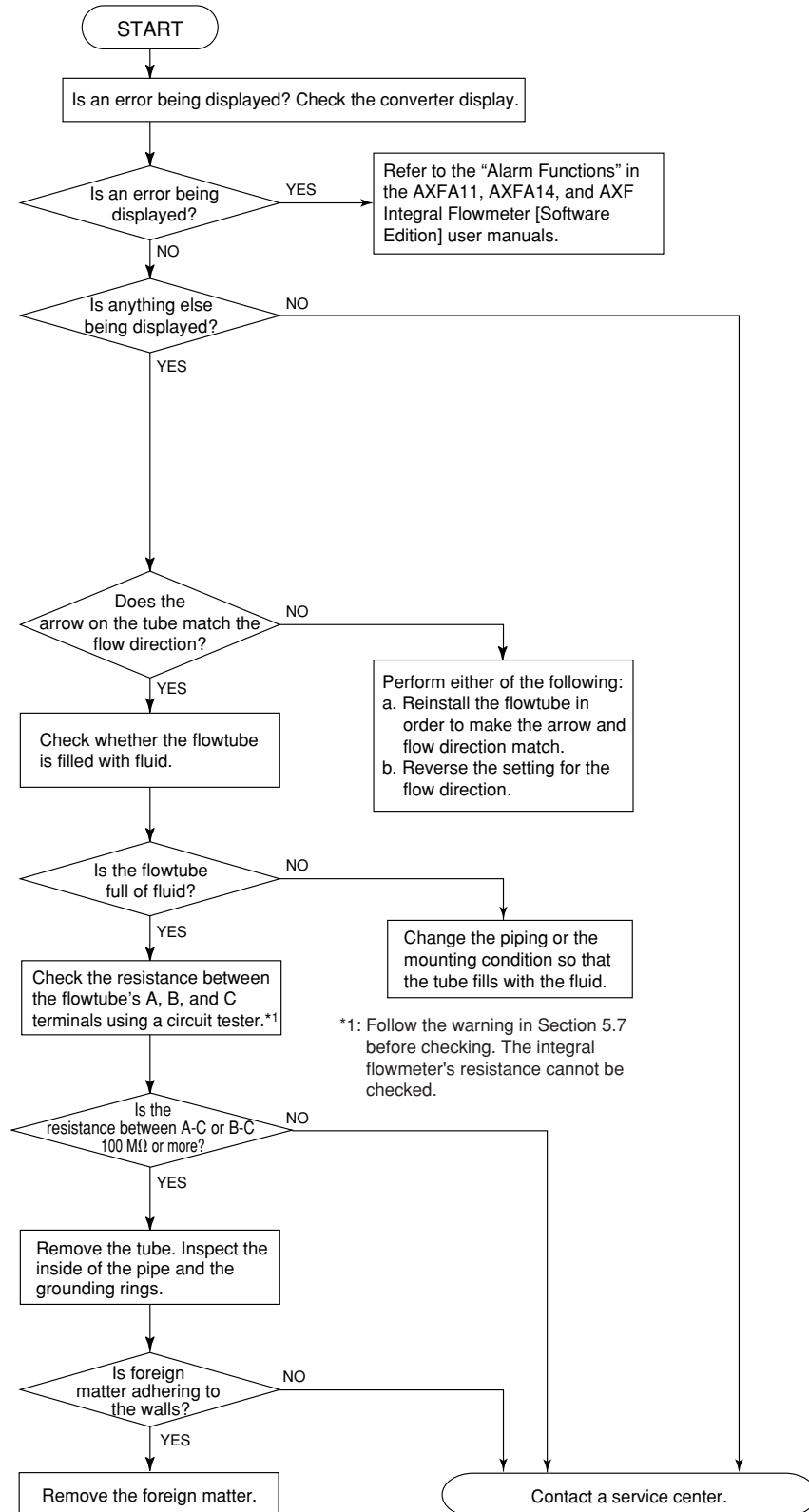

F0521.EPS

5.9.2 Unstable Zero

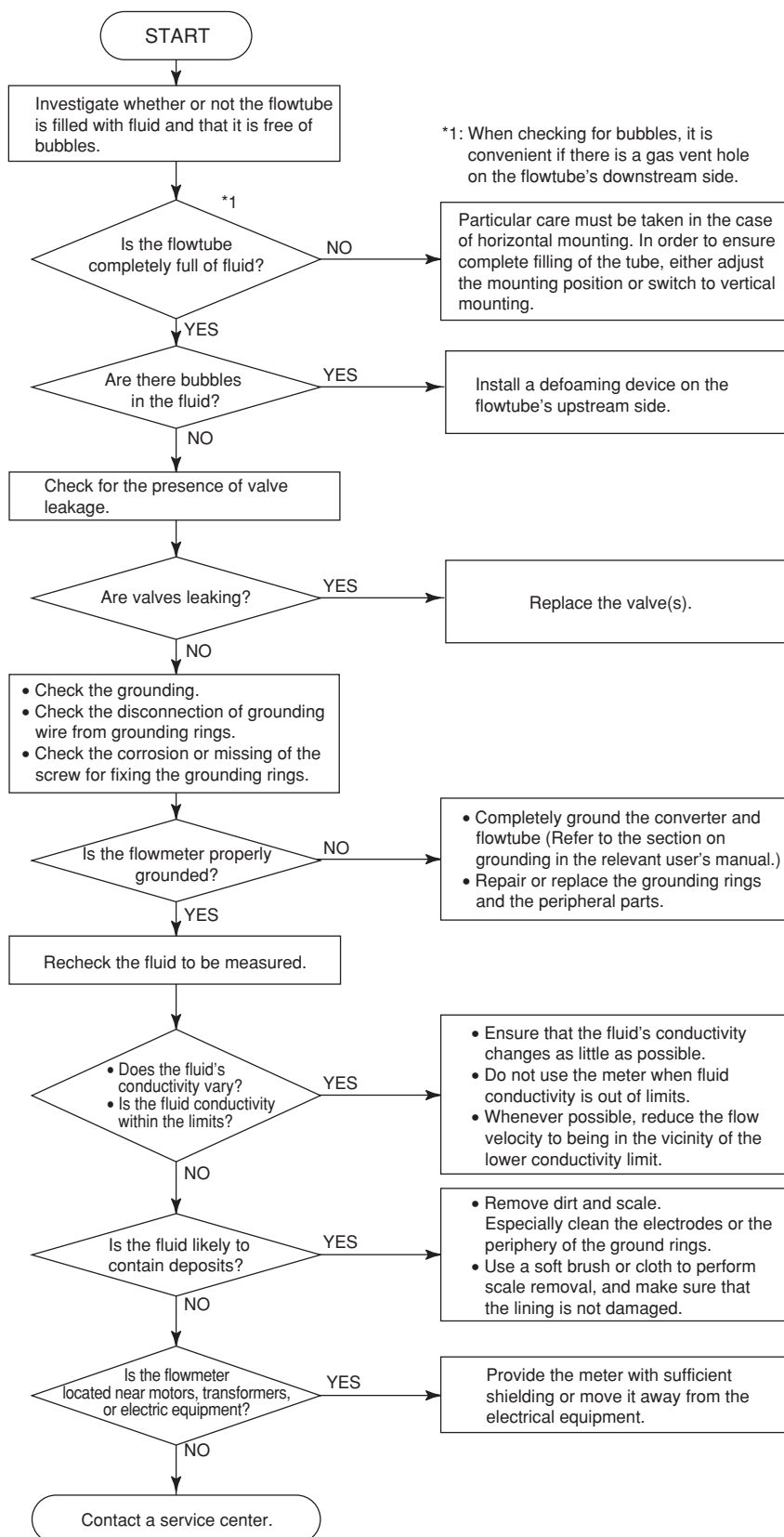

F0522.EPS

5.9.3 Disagreement Between Indication and Actual Flow

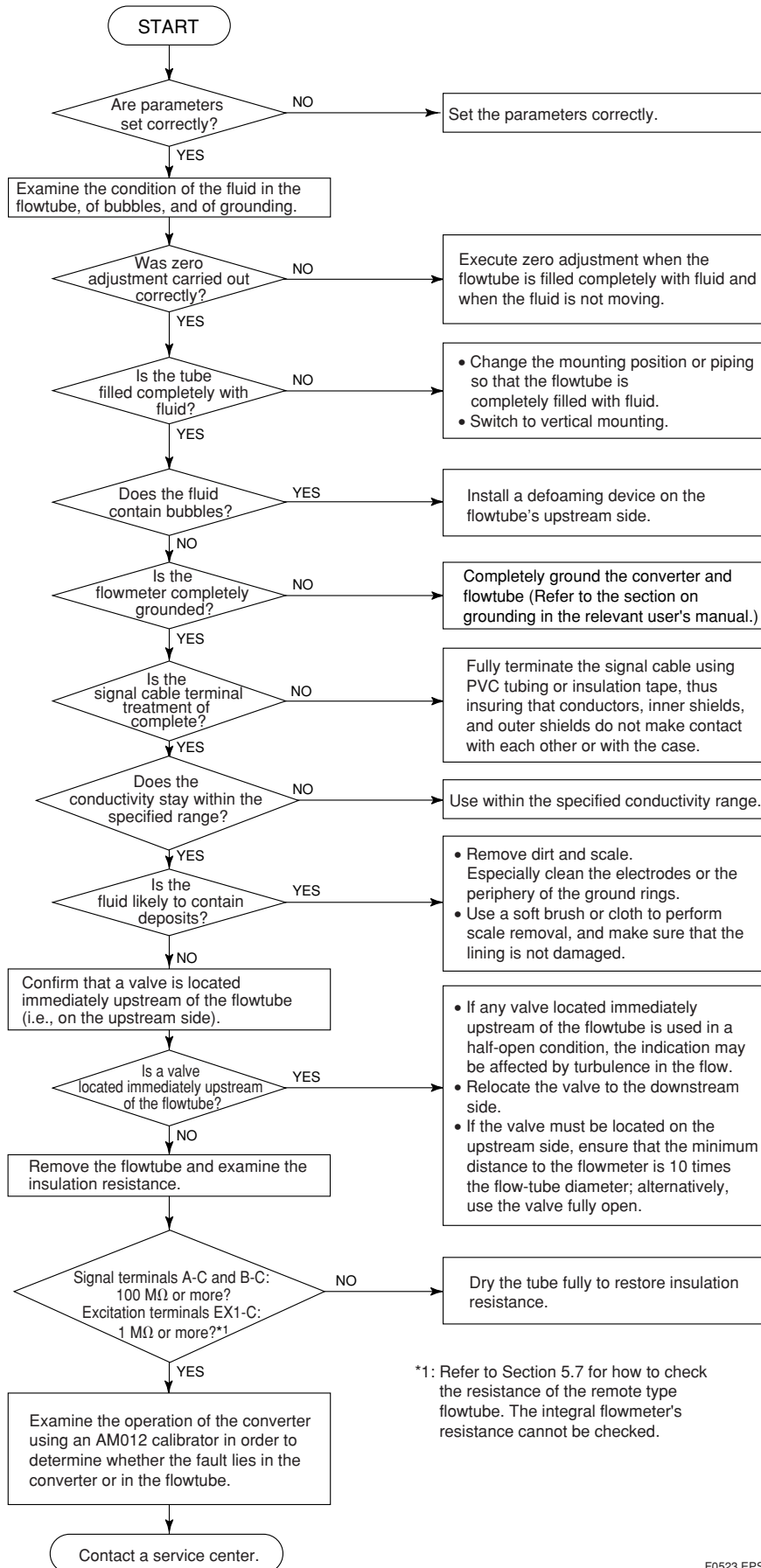

*1: Refer to Section 5.7 for how to check the resistance of the remote type flowtube. The integral flowmeter's resistance cannot be checked.

F0523.EPS

6. OUTLINE

■ STANDARD SPECIFICATIONS

Refer to IM 01E20F02-01E for FOUNDATION Fieldbus communication type and IM 01E20F12-01E for PROFIBUS PA communication type regarding the items marked with “◇”.

● Converter (Integral flowmeter)

The contents of (*1) and (*2) described in the converter specifications are follows.

*1: Select two points from: one pulse output, one alarm output, one status input, or two status outputs.

*2: For models without an indicator, the configuration tool (Such as HHT (handheld terminal) or FieldMate™, etc.) is necessary to set parameters.

Excitation Method:

- Standard dual frequency excitation:
Size 2.5 to 400 mm (0.1 to 16 in.)
- Enhanced dual frequency excitation:
Size 25 to 200 mm (1.0 to 8.0 in.)
(Optional code HF1 or HF2)

Input Signal (*1) “◇”:

One Status Input: Dry contact
Load Resistance: 200 Ω or less (ON), 100 kΩ or more (OFF)

Output Signals “◇”:

- One Current Output: 4 to 20 mA DC (load resistance: 750Ω maximum, including cable resistance)
- One Pulse Output (*1):
Transistor contact output (open collector)
Contact capacity: 30 V DC (OFF), 200 mA (ON)
Output rate: 0.0001 to 10,000 pps (pulse/second)
- One Alarm Output (*1):
Transistor contact output (open collector)
Contact capacity: 30 V DC (OFF), 200 mA (ON)
- Two Status Outputs (*1):
Transistor contact output (open collector)
Contact capacity: 30 V DC (OFF), 200 mA (ON)

Communication Signals “◇”:

BRAIN or HART communication signal
(Superimposed on the 4 to 20 mA DC signal)
Distance from Power Line: 15 cm (6 in.) or more
(Parallel wiring should be avoided.)

BRAIN:

Communication Distance:

Up to 1.5 km (0.93 miles), when polyethylene insulated PVC-sheathed cables (CEV cables) are used.
Communication distance varies depending on the type of cable and wiring used.

Load Resistance:

250 to 450Ω (including cable resistance)

Load Capacitance: 0.22 μF or less

Load Inductance: 3.3 mH or less

Input Impedance of Communicating Device:

10 kΩ or more (at 2.4 kHz)

HART:

Load Resistance:

250 to 600Ω (including cable resistance)

Note: HART is a registered trademark of the FieldComm Group.

Data Security During Power Failure:

Data (parameters, totalizer value, etc.) storage by EEPROM. No back-up battery required.

Indicator (*2):

Full dot-matrix LCD (32×132 pixels)

Lightning Protector:

The lightning protector is built into the current output and pulse/alarm/status input and output terminals. When optional code A is selected, the lightning protector is built into the power terminals.

Protection:

General-purpose Use/Sanitary Type/TIIS Flameproof type:

IP66/IP67

Explosion proof type except TIIS:

In case of explosion proof type except TIIS, refer to description of "Enclosure" in "HAZARDOUS AREA CLASSIFICATION".

Coating:

Case and Cover: Corrosion-resistant coating

Coating Color: Mint green coating (Munsell 5.6 BG 3.3/2.9 or its equivalent)

Converter Material:

Case and Cover : Aluminum alloy

Mounting/Shapes (Integral Flowmeter):

- Electrical Connection: ANSI 1/2 NPT female
ISO M20 ×1.5 female
JIS G1/2 female
- Direction of Electrical Connection: The direction can be changed even after delivery.
- Terminal Connection: M4 size screw terminal

Grounding:

Grounding resistance 100 Ω or less

When optional code A is selected, grounding resistance 10 Ω or less shall be applied.

* In case of explosion proof type except TIIS, follow the domestic electrical requirements as regulated in each country.

* In case of TIIS Flameproof type, refer to description of "HAZARDOUS AREA CLASSIFICATION".

Functions “◇”

How to Set Parameters (*2):

The indicator's LCD and three infra-red switches enable users to set parameters without opening the case cover. Parameters can also be set with the configuration tool (Such as HHT (handheld terminal) or FieldMate, etc.).

The language for the HHT is English only.

Displayed Languages (*2):

Users can choose a language from among English, Japanese, German, French, Italian, and Spanish.

Instantaneous Flow Rate/Totalized Value Display Functions (for models with an indicator) (*2):

The full dot-matrix LCD enables user selections of displays from one line to three lines for:

- Instantaneous flow rate
- Instantaneous flow rate (%)
- Instantaneous flow rate (bar graph)
- Current output value (mA)
- Totalized forward-direction flow rate
- Totalized reverse-direction flow rate
- Totalized differential flow rate
- Tag No.
- Results of electrode adhesion diagnostics
- Communication type

Totalizer Display Function (*2):

The flow rate is counted one pulse at a time according to the setting of totalization pulse weights. For forward and reverse flow measurement functions, the totalized values of the flow direction (forward or reverse) and the flow direction are displayed on the indicator together with the units. The difference of totalized values between the forward and reverse flow rate can be displayed. Totalization for the reverse flow rate is carried out only when “Forward and reverse flow measurement functions” is selected.

Damping Time Constant (*2):

Time constant can be set from 0.1 second to 200.0 seconds (63% response). The default is 3 seconds.

Span Setting Function (*2):

Span flows can be set in units such as volume flow rate, mass flow rate, time, or flow rate value. The velocity unit can also be set.

Volume Flow Rate Unit: kcf, cf, mcf, Mgal (US), kgal (US), gal (US), mgal (US), kbbbl (US)*, bbl (US)*, mbbbl (US)*, μbbbl (US)*, MI (megaliter), m³, kl (kiloliter), l (liter), cm³

Mass Flow Rate Unit (Density must be set.):

klb (US), lb (US), t (ton), kg, g

Velocity Unit: ft, m (meter)

Time Unit: s (sec), min, h (hour), d (day)

* “US oil” or “US Beer” can be selected.

Pulse Output (*1)(*2):

Scaled pulse can be output by setting a pulse weight.

Pulse Width: Duty 50% or fixed pulse width (0.05, 0.1, 0.5, 1, 20, 33, 50, 100 ms) can be selected.

Output Rate: 0.0001 to 10,000 pps (pulse/second)

Multi-range Function (*1)(*2):

- Range switching via status input
 - Status input enables the switching of up to two ranges.
- Automatic range switching
 - When the flow rate exceeds 100 % of the range, transition to the next range (up to four ranges) is carried out automatically. Range switching can be confirmed by status outputs and indicator.

Forward and Reverse Flow Measurement Functions (*1)(*2):

Flows in both forward and reverse directions can be measured. The reverse flow measurement can be confirmed by status output and indicator.

Totalization Switch (*1)(*2):

The status output is carried out when a totalized value becomes equal to or greater than the set value.

Preset Totalization (*1)(*2):

The parameter setting or status input enables a totalized value to be preset to a setting value or zero.

0% Signal Lock (*1)(*2):

Status input forcibly fixes the instantaneous flow rate display, current output, pulse output, and flow rate totalization to 0%.

Alarm Selection Function (*2):

Alarms are classified into the System Alarms (hard failures), Process Alarms (such as ‘Empty Pipe’, ‘Signal Overflow’ and ‘Adhesion Alarm’), Setting Alarms, and Warnings.

Whether alarms should be generated or not can be selected for each item.

The current output generated for an alarm can be selected from among 2.4 mA or less, fixed to 4 mA, 21.6 mA or more, or HOLD.

Alarm Output (*1)(*2):

Alarms are generated only for the items selected via the ‘Alarm Selection Function’ if relevant failures occur.

Self Diagnostics Functions (*2):

If alarms are generated, details of the System Alarms, Process Alarms, Setting Alarms and Warnings are displayed together with concrete descriptions of countermeasures.

Flow Upper/Lower Limit Alarms (*1)(*2):

If a flow rate becomes greater or smaller than the set value, this alarm is generated. In addition, two upper limits (H, HH) and two lower limits (L, LL) can be set.

If a flow rate becomes greater or smaller than any of the set values, the status is output.

Electrode Adhesion Diagnostics Function (*1) (*2):

This function enables monitoring of the adhesion level of insulating substances to the electrodes. Depending on the status of adhesion, users are notified by a warning or an alarm via status outputs. If replaceable electrodes are used, they can be removed and cleaned when adhesion occurs.

● Flowtubes (Remote Flowtube/Integral Flowmeter)

Size of AXF Flowtubes: AXF Standard (Lay length code 1)

Unit: mm (in.)

Use	Process Connection	Lining	Remote Flowtube	Integral Flowmeter	High Grade Accuracy 0.2% of Rate (*3)	Enhanced Dual Frequency Excitation (Optional code HF1,HF2) (*3)	Replaceable Electrode (Electrode structure code 2)
General-purpose Use	Wafer	PFA	2.5 (0.1), 5 (0.2), 10 (0.4), 15 (0.5), 25 (1.0), 32 (1.25), 40 (1.5), 50 (2.0), 65 (2.5), 80 (3.0), 100 (4.0), 125 (5.0), 150 (6.0), 200 (8.0), 250 (10), 300 (12)		25 (1.0), 32 (1.25), 40 (1.5), 50 (2.0), 65 (2.5), 80 (3.0), 100 (4.0), 125 (5.0), 150 (6.0), 200 (8.0)	25 (1.0), 32 (1.25), 40 (1.5), 50 (2.0), 65 (2.5), 80 (3.0), 100 (4.0), 125 (5.0), 150 (6.0), 200 (8.0)	25 (1.0), 32 (1.25), 40 (1.5), 50 (2.0), 65 (2.5), 80 (3.0), 100 (4.0), 125 (5.0), 150 (6.0), 200 (8.0), 250 (10), 300 (12)
		Polyurethane Rubber	25 (1.0), 32 (1.25), 40 (1.5), 50 (2.0), 65 (2.5), 80 (3.0), 100 (4.0), 125 (5.0), 150 (6.0), 200 (8.0), 250 (10), 300 (12)		—	25 (1.0), 32 (1.25), 40 (1.5), 50 (2.0), 65 (2.5), 80 (3.0), 100 (4.0), 125 (5.0), 150 (6.0), 200 (8.0)	25 (1.0), 32 (1.25), 40 (1.5), 50 (2.0), 65 (2.5), 80 (3.0), 100 (4.0), 125 (5.0), 150 (6.0), 200 (8.0), 250 (10), 300 (12)
		Natural Soft Rubber	50 (2.0), 65 (2.5), 80 (3.0), 100 (4.0), 125 (5.0), 150 (6.0), 200 (8.0), 250 (10), 300 (12)		—	50 (2.0), 65 (2.5), 80 (3.0), 100 (4.0), 125 (5.0), 150 (6.0), 200 (8.0)	—
		EPDM Rubber	50 (2.0), 65 (2.5), 80 (3.0), 100 (4.0), 125 (5.0), 150 (6.0), 200 (8.0), 250 (10), 300 (12)		—	50 (2.0), 65 (2.5), 80 (3.0), 100 (4.0), 125 (5.0), 150 (6.0), 200 (8.0)	—
		Ceramics (*1)	15 (0.5), 25 (1.0), 40 (1.5), 50 (2.0), 80 (3.0), 100 (4.0), 150 (6.0), 200 (8.0)	25 (1.0), 40 (1.5), 50 (2.0), 80 (3.0), 100 (4.0), 150 (6.0), 200 (8.0)	25 (1.0), 40 (1.5), 50 (2.0), 80 (3.0), 100 (4.0), 150 (6.0), 200 (8.0)	25 (1.0), 40 (1.5), 50 (2.0), 80 (3.0), 100 (4.0), 150 (6.0), 200 (8.0)	—
	Flange	PFA	2.5 (0.1), 5 (0.2), 10 (0.4), 15 (0.5), 25 (1.0), 32 (1.25), 40 (1.5), 50 (2.0), 65 (2.5), 80 (3.0), 100 (4.0), 125 (5.0), 150 (6.0), 200 (8.0), 250 (10), 300 (12), 350 (14), 400 (16)		25 (1.0), 32 (1.25), 40 (1.5), 50 (2.0), 65 (2.5), 80 (3.0), 100 (4.0), 125 (5.0), 150 (6.0), 200 (8.0)	25 (1.0), 32 (1.25), 40 (1.5), 50 (2.0), 65 (2.5), 80 (3.0), 100 (4.0), 125 (5.0), 150 (6.0), 200 (8.0)	25 (1.0), 32 (1.25), 40 (1.5), 50 (2.0), 65 (2.5), 80 (3.0), 100 (4.0), 125 (5.0), 150 (6.0), 200 (8.0), 250 (10), 300 (12), 350 (14), 400 (16)
		Polyurethane Rubber	25 (1.0), 32 (1.25), 40 (1.5), 50 (2.0), 65 (2.5), 80 (3.0), 100 (4.0), 125 (5.0), 150 (6.0), 200 (8.0), 250 (10), 300 (12), 350 (14), 400 (16)	25 (1.0), 32 (1.25), 40 (1.5), 50 (2.0), 65 (2.5), 80 (3.0), 100 (4.0), 125 (5.0), 150 (6.0), 200 (8.0), 250 (10), 300 (12), 350 (14), 400 (16)	—	25 (1.0), 32 (1.25), 40 (1.5), 50 (2.0), 65 (2.5), 80 (3.0), 100 (4.0), 125 (5.0), 150 (6.0), 200 (8.0)	25 (1.0), 32 (1.25), 40 (1.5), 50 (2.0), 65 (2.5), 80 (3.0), 100 (4.0), 125 (5.0), 150 (6.0), 200 (8.0), 250 (10), 300 (12), 350 (14), 400 (16)
		Natural Soft Rubber	50 (2.0), 65 (2.5), 80 (3.0), 100 (4.0), 125 (5.0), 150 (6.0), 200 (8.0), 250 (10), 300 (12), 350(14), 400(16)		—	50 (2.0), 65 (2.5), 80 (3.0), 100 (4.0), 125 (5.0), 150 (6.0), 200 (8.0)	—
		EPDM Rubber	50 (2.0), 65 (2.5), 80 (3.0), 100 (4.0), 125 (5.0), 150 (6.0), 200 (8.0), 250 (10), 300 (12), 350(14), 400(16)		—	50 (2.0), 65 (2.5), 80 (3.0), 100 (4.0), 125 (5.0), 150 (6.0), 200 (8.0)	—
		Union Joint	Ceramics (*2)	2.5 (0.1), 5 (0.2), 10 (0.4)		—	—

Size of AXF Flowtubes: AXF Standard (Lay length code 1) (continued)

Unit: mm (in.)

Use	Process Connection	Lining	Remote Flowtube	Integral Flowmeter	High Grade Accuracy 0.2% of Rate (*3)	Enhanced Dual Frequency Excitation (Optional code HF1,HF2) (*3)	Replaceable Electrode (Electrode structure code 2)	
Submersible Type	Wafer	PFA	15 (0.5), 25 (1.0), 32 (1.25), 40 (1.5), 50 (2.0), 65 (2.5), 80 (3.0), 100 (4.0), 125 (5.0), 150 (6.0), 200 (8.0), 250 (10), 300 (12)	—	25 (1.0), 32 (1.25), 40 (1.5), 50 (2.0), 65 (2.5), 80 (3.0), 100 (4.0), 125 (5.0), 150 (6.0), 200 (8.0)	25 (1.0), 32 (1.25), 40 (1.5), 50 (2.0), 65 (2.5), 80 (3.0), 100 (4.0), 125 (5.0), 150 (6.0), 200 (8.0)	—	
		Polyurethane Rubber	25 (1.0), 32 (1.25), 40 (1.5), 50 (2.0), 65 (2.5), 80 (3.0), 100 (4.0), 125 (5.0), 150 (6.0), 200 (8.0), 250 (10), 300 (12)	—	—	25 (1.0), 32 (1.25), 40 (1.5), 50 (2.0), 65 (2.5), 80 (3.0), 100 (4.0), 125 (5.0), 150 (6.0), 200 (8.0)	—	
		Natural Soft Rubber	50 (2.0), 65 (2.5), 80 (3.0), 100 (4.0), 125 (5.0), 150 (6.0), 200 (8.0), 250 (10), 300 (12)	—	—	—	50 (2.0), 65 (2.5), 80 (3.0), 100 (4.0), 125 (5.0), 150 (6.0), 200 (8.0)	—
		EPDM Rubber	50 (2.0), 65 (2.5), 80 (3.0), 100 (4.0), 125 (5.0), 150 (6.0), 200 (8.0), 250 (10), 300 (12)	—	—	—	50 (2.0), 65 (2.5), 80 (3.0), 100 (4.0), 125 (5.0), 150 (6.0), 200 (8.0)	—
	Flange	PFA	15 (0.5), 25 (1.0), 32 (1.25), 40 (1.5), 50 (2.0), 65 (2.5), 80 (3.0), 100 (4.0), 125 (5.0), 150 (6.0), 200 (8.0), 250 (10), 300 (12), 350 (14), 400 (16)	—	25 (1.0), 32 (1.25), 40 (1.5), 50 (2.0), 65 (2.5), 80 (3.0), 100 (4.0), 125 (5.0), 150 (6.0), 200 (8.0)	25 (1.0), 32 (1.25), 40 (1.5), 50 (2.0), 65 (2.5), 80 (3.0), 100 (4.0), 125 (5.0), 150 (6.0), 200 (8.0)	—	
		Polyurethane Rubber	25 (1.0), 32 (1.25), 40 (1.5), 50 (2.0), 65 (2.5), 80 (3.0), 100 (4.0), 125 (5.0), 150 (6.0), 200 (8.0), 250 (10), 300 (12), 350 (14), 400 (16)	—	—	25 (1.0), 32 (1.25), 40 (1.5), 50 (2.0), 65 (2.5), 80 (3.0), 100 (4.0), 125 (5.0), 150 (6.0), 200 (8.0)	—	
		Natural Soft Rubber	50 (2.0), 65 (2.5), 80 (3.0), 100 (4.0), 125 (5.0), 150 (6.0), 200 (8.0), 250 (10), 300 (12), 350 (14), 400 (16)	—	—	—	50 (2.0), 65 (2.5), 80 (3.0), 100 (4.0), 125 (5.0), 150 (6.0), 200 (8.0)	—
		EPDM Rubber	50 (2.0), 65 (2.5), 80 (3.0), 100 (4.0), 125 (5.0), 150 (6.0), 200 (8.0), 250 (10), 300 (12), 350 (14), 400 (16)	—	—	—	50 (2.0), 65 (2.5), 80 (3.0), 100 (4.0), 125 (5.0), 150 (6.0), 200 (8.0)	—
Explosion proof Type	Wafer	PFA	2.5 (0.1), 5 (0.2), 10 (0.4), 15 (0.5), 25 (1.0), 32 (1.25), 40 (1.5), 50 (2.0), 65 (2.5), 80 (3.0), 100 (4.0), 125 (5.0), 150 (6.0), 200 (8.0), 250 (10), 300 (12)	—	25 (1.0), 32 (1.25), 40 (1.5), 50 (2.0), 65 (2.5), 80 (3.0), 100 (4.0), 125 (5.0), 150 (6.0), 200 (8.0)	25 (1.0), 32 (1.25), 40 (1.5), 50 (2.0), 65 (2.5), 80 (3.0), 100 (4.0), 125 (5.0), 150 (6.0), 200 (8.0)	—	
		Ceramics (*1)	15 (0.5), 25 (1.0), 40 (1.5), 50 (2.0), 80 (3.0), 100 (4.0), 150 (6.0), 200 (8.0)	—	25 (1.0), 40 (1.5), 50 (2.0), 80 (3.0), 100 (4.0), 150 (6.0), 200 (8.0)	25 (1.0), 40 (1.5), 50 (2.0), 80 (3.0), 100 (4.0), 150 (6.0), 200 (8.0)	—	
	Flange	PFA	2.5 (0.1), 5 (0.2), 10 (0.4), 15 (0.5), 25 (1.0), 32 (1.25), 40 (1.5), 50 (2.0), 65 (2.5), 80 (3.0), 100 (4.0), 125 (5.0), 150 (6.0), 200 (8.0), 250 (10), 300 (12), 350 (14), 400 (16)	—	25 (1.0), 32 (1.25), 40 (1.5), 50 (2.0), 65 (2.5), 80 (3.0), 100 (4.0), 125 (5.0), 150 (6.0), 200 (8.0)	25 (1.0), 32 (1.25), 40 (1.5), 50 (2.0), 65 (2.5), 80 (3.0), 100 (4.0), 125 (5.0), 150 (6.0), 200 (8.0)	—	
		Union Joint	Ceramics (*2)	2.5 (0.1), 5 (0.2), 10 (0.4)	—	—	—	—
Sanitary Type	Clamp: Tri-Clamp (*4), DIN32676 ISO2852/SMS3016 Union: DIN11851 ISO2853 (*5) SMS1145 (*6) Butt Weld: DIN11850, ISO203	PFA	15 (0.5), 25 (1.0), 32 (1.25), 40 (1.5), 50 (2.0), 65 (2.5), 80 (3.0), 100 (4.0), 125 (5.0)	—	25 (1.0), 32 (1.25), 40 (1.5), 50 (2.0), 65 (2.5), 80 (3.0), 100 (4.0), 125 (5.0)	25 (1.0), 32 (1.25), 40 (1.5), 50 (2.0), 65 (2.5), 80 (3.0), 100 (4.0), 125 (5.0)	—	

*1: AXF standard lay length dimensions for wafer type ceramics linings are the same as those for ADMAG ceramics linings.

*2: AXF standard lay length dimensions for union joint type ceramics linings are the same as those for ADMAG ceramics linings.

*3: Enhanced dual frequency excitation is not available for models with High grade accuracy.

*4: Not available with 32 mm (1.25 in.), 125 mm (5.0 in.)

*5: Not available with 125 mm (5.0 in.)

*6: Not available with 15 mm (0.5 in.), 125 mm (5.0 in.)

T21.EPS

Size of AXF Flowtubes: Replacement model for earlier ADMAG or ADMAG AE (Lay length code 2)

Unit: mm (in.)

Use	Process Connection	Lining	Remote Flowtube	Integral Flowmeter	High Grade Accuracy 0.2% of Rate	Enhanced Dual Frequency Excitation (Optional code HF1, HF2)	Replaceable Electrode (Electrode structure code 2)
General-purpose use	Wafer (*6)	PFA	2.5 (0.1), 5 (0.2), 10 (0.4), 15 (0.5), 25 (1.0), 40 (1.5), 50 (2.0), 80 (3.0), 100 (4.0), 150 (6.0), 200 (8.0)		—	25 (1.0), 40 (1.5), 50 (2.0), 80 (3.0), 100 (4.0), 150 (6.0), 200 (8.0)	—
		Polyurethane rubber	25 (1.0), 40 (1.5), 50 (2.0), 80 (3.0), 100 (4.0), 150 (6.0), 200 (8.0)		—	25 (1.0), 40 (1.5), 50 (2.0), 80 (3.0), 100 (4.0), 150 (6.0), 200 (8.0)	—
	Flange (*7)	PFA	150 (6.0), 200 (8.0), 250 (10)		—	150 (6.0), 200 (8.0)	150 (6.0), 200 (8.0), 250 (10)
		Polyurethane rubber	150 (6.0), 200 (8.0), 250 (10)		—	150 (6.0), 200 (8.0)	150 (6.0), 200 (8.0), 250 (10)
Submersible Type	Wafer (*6)	PFA	15 (0.5), 25 (1.0), 40 (1.5), 50 (2.0), 80 (3.0), 100 (4.0), 150 (6.0), 200 (8.0)	—	—	25 (1.0), 40 (1.5), 50 (2.0), 80 (3.0), 100 (4.0), 150 (6.0), 200 (8.0)	—
		Polyurethane rubber	25 (1.0), 40 (1.5), 50 (2.0), 80 (3.0), 100 (4.0), 150 (6.0), 200 (8.0)	—	—	25 (1.0), 40 (1.5), 50 (2.0), 80 (3.0), 100 (4.0), 150 (6.0), 200 (8.0)	—
	Flange (*7)	PFA	150 (6.0), 200 (8.0), 250 (10)	—	—	150 (6.0), 200 (8.0)	—
		Polyurethane rubber	150 (6.0), 200 (8.0), 250 (10)	—	—	150 (6.0), 200 (8.0)	—
Explosion proof type	Wafer (*6)	PFA	2.5 (0.1), 5 (0.2), 10 (0.4), 15 (0.5), 25 (1.0), 40 (1.5), 50 (2.0), 80 (3.0), 100 (4.0), 150 (6.0), 200 (8.0)		—	25 (1.0), 40 (1.5), 50 (2.0), 80 (3.0), 100 (4.0), 150 (6.0), 200 (8.0)	—
	Flange (*7)	PFA	150 (6.0), 200 (8.0), 250 (10)		—	150 (6.0), 200 (8.0)	—

T22.EPS

- *6: ADMAG lay length dimensions for wafer type of 250 mm (10 in.), and 300 mm (12 in.) are the same as those for AXF Standard. And, in case of "platinum-iridium (grounding ring code P) or tantalum (grounding ring code T) or None (grounding ring code N)" in wafer type of 2.5 mm (0.1 in.) to 15 mm (0.5 in.), the lay lengths of Replacement model are the same as those for AXF Standard.
- *7: ADMAG lay length dimensions for flange type of 15 mm (0.5 in.) to 100 mm (4.0 in.), or 300 mm (12 in.) to 400 mm (16 in.) are the same as those for AXF Standard. However, in case of platinum-iridium (grounding ring code P) or tantalum (grounding ring code T) or None (grounding ring code N) in flange type of 15 mm (0.5 in.) to 100 mm (4.0 in.), the lay length of AXF Standard are longer by approx. 4mm (0.16 in.) than those of earlier ADMAG or ADMAG AE.

Protection:**General-Purpose Use/Sanitary Type/TIIS Flameproof Type:**

IP66/IP67

Explosion proof type except TIIS:

In case of explosion proof type except TIIS, refer to description of "Enclosure" in "HAZARDOUS AREA CLASSIFICATION".

Submersible Type (only for Remote Flowtube):

IP68 (Conforms to continuous immersion under the following test condition)

Test Condition:

50 m below the surface of the water, equivalent to 0.5 MPa hydraulic pressure, for one month.
Cable should be protected at customer site.

Coating:**General-Purpose Use/Explosion proof Type:**

Size 2.5 to 125 mm (0.1 to 5.0 in.) (Process connection code A** of wafer type),

Size 2.5 to 125 mm (0.1 to 5.0 in.) (Process connection code B**, P** of flange type),

Size 2.5 to 10 mm (0.1 to 0.4 in.) (Process connection code D** of flange type):

- Housing, Flange (Flange type only) :

- No coating (Stainless steel surface)

- Terminal Box and Cover (Remote Flowtube):

- Corrosion-resistant coating

- Coating color; Mint green (Munsell 5.6 BG 3.3/2.9 or its equivalent)

Size 150 to 300 mm (6.0 to 12 in.) (Process connection code A** of wafer type),

Size 150 to 400 mm (6.0 to 16 in.) (Process connection code B**, P** of flange type),

Size 50 to 400 mm (2.0 to 16 in.) (Process connection code C** of flange type):

- Housing, Flange (Flange type only), Terminal Box

- and Cover (Remote Flowtube):

- Corrosion-resistant coating

- Coating color; Mint green (Munsell 5.6 BG 3.3/2.9 or its equivalent)

Sanitary Type:

Size 15 to 125 mm (0.5 to 5.0 in.):

- Housing: No coating (Stainless steel surface)

- Adapter : No coating (Stainless steel surface)

- Terminal Box and Cover (Remote Flowtube):

- Corrosion-resistant coating

- Coating color; Mint green (Munsell 5.6 BG 3.3/2.9 or its equivalent)

Submersible Type: Non-tar epoxy coating (black)

Flowtube Material:

Size 2.5 mm (0.1 in.) to 15 mm (0.5 in.)

Part Name		Material
Housing		Stainless steel-JIS SCS11 equivalent
Flange	Process Connection code: B**	Stainless steel-JIS SUS304 (AISI 304 SS/EN 1.4301 equivalent) or SUSF304
	Process Connection code: D** [2.5 mm (0.1 in.) to 10 mm (0.4 in.)]	Stainless steel-JIS SUS304 (AISI 304 SS/EN 1.4301 equivalent) or SUSF304
	Process Connection code: P**	Stainless steel-JIS SUSF316
Mini-Flange	Wafer Type PFA/Polyurethane Rubber lining	Stainless steel-JIS SCS13 (EN 1.4308 equivalent)
	Wafer Type Ceramics lining [only for 15 mm (0.5 in.)]	Stainless steel-JIS SUS316L (AISI 316 SS/EN 1.4404 equivalent)
	Sanitary Type [only for 15 mm (0.5 in.)]	Stainless steel-JIS SCS13 (EN 1.4308 equivalent)
Pipe	Wafer Type PFA/Polyurethane Rubber lining	Stainless steel-JIS SCS13 (EN 1.4308 equivalent)
	Wafer Type/Union Joint Ceramics lining	Alumina ceramics (99.9%)
	Flange Type PFA lining	Stainless steel-JIS SCS13 (EN 1.4308 equivalent) and SUS304 (AISI 304 SS/EN 1.4301 equivalent)
	Sanitary Type [only for 15 mm (0.5 in.)]	Stainless steel-JIS SCS13 (EN 1.4308 equivalent)
Terminal Box (Remote Flowtube)		Aluminum alloy

T03.EPS

Size 25 mm (1.0 in.) to 125 mm (5.0 in.)

Part Name		Material		
Housing		Stainless steel-JIS SUS304 (AISI 304 SS/EN 1.4301 equivalent)		
Flange	Process Connection code: B**	Stainless steel-JIS SUS304 (AISI 304 SS/EN 1.4301 equivalent) or SUSF304		
	Process Connection code: C** [50 mm (2.0 in.) to 125 mm (5.0 in.)]	Carbon steel-JIS SS400 or SFVC 2A		
	Process Connection code: P** [Except 32 mm (1.25 in.), 65 mm (2.5 in.) and 125 mm (5.0 in.)]	Stainless steel-JIS SUSF316		
Mini-Flange	Wafer Type PFA/Polyurethane Rubber/ Natural Soft Rubber/ EPDM Rubber lining	Size 25 mm (1.0 in.) (Lay Length code 1)	Stainless steel-JIS SCS13 or EN 1.4308 (SCS13 equivalent)	
		Size 25 mm (1.0 in.) (Lay Length code 2)	Stainless steel-JIS SUS430 (ASTM 43000/DIN X6Cr17/EN 1.4016 equivalent)	
		Size 32 mm (1.25 in.) to 125 mm (5.0 in.)	Stainless steel-JIS SUS430 (ASTM 43000/DIN X6Cr17/EN 1.4016 equivalent)	
	Wafer Type Ceramics lining	Size 25 mm (1.0 in.) to 50 mm (2.0 in.)	Stainless steel-JIS SUS316L (AISI 316L SS/EN 1.4404 equivalent)	
		Size 80 mm (3.0 in.), 100 mm (4.0 in.)	Stainless steel-JIS SUS304 (AISI 304 SS/EN 1.4301 equivalent)	
	Sanitary Type	Size 25 mm (1.0 in.)	Stainless steel-JIS SCS13 (EN 1.4308 equivalent)	
		Size 32 mm (1.25 in.) to 125 mm (5.0 in.)	Stainless steel-JIS SUS304 (AISI 304 SS/EN 1.4301 equivalent) or SUSF304	
	Pipe	Wafer Type PFA/Polyurethane Rubber/ Natural Soft Rubber/ EPDM Rubber lining	Size 25 mm (1.0 in.) (Lay Length code 1)	Stainless steel-JIS SCS13 or EN 1.4308 (SCS13 equivalent)
			Size 25 mm (1.0 in.) (Lay Length code 2)	Stainless steel-JIS SUS304 (AISI 304 SS/EN 1.4301 equivalent)
Size 32 mm (1.25 in.) to 125 mm (5.0 in.)			Stainless steel-JIS SUS304 (AISI 304 SS/EN 1.4301 equivalent)	
Flange Type PFA/Polyurethane Rubber/ Natural Soft Rubber/ EPDM Rubber lining		Size 25 mm (1.0 in.)	Stainless steel-JIS SCS13 or EN 1.4308 (SCS13 equivalent)	
		Size 32 mm (1.25 in.) to 125 mm (5.0 in.)	Stainless steel-JIS SUS304 (AISI 304 SS/EN 1.4301 equivalent)	
Wafer Type Ceramics lining		Size 25 mm (1.0 in.) to 100 mm (4.0 in.)	Alumina ceramics (99.9%)	
Sanitary Type		Size 25 mm (1.0 in.)	Stainless steel-JIS SCS13 (EN 1.4308 equivalent)	
		Size 32 mm (1.25 in.) to 125 mm (5.0 in.)	Stainless steel-JIS SUS304 (AISI 304 SS/EN 1.4301 equivalent)	
Terminal Box (Remote Flowtube)		Aluminum alloy		

T04.EPS

Size 150 mm (6.0 in.) to 400 mm (16 in.)

Part Name		Material
Housing		Carbon steel-JIS SPCC equivalent
Flange	Process Connection code: B**	Stainless steel-JIS SUS304 (AISI 304 SS/EN 1.4301 equivalent) or SUSF304
	Process Connection code: C**	Carbon steel-JIS SS400 or SFVC 2A
	Process Connection code: P**	Stainless steel-JIS SUSF316
Mini-Flange	Wafer Type PFA/Polyurethane Rubber/Natural Soft Rubber/EPDM Rubber lining	Carbon steel-JIS SS400 or SFVC 2A
	Wafer Type Ceramics lining (available with 150 mm (6.0 in.), 200 mm (8.0 in.))	Stainless steel-JIS SUS304 (AISI 304 SS/EN 1.4301 equivalent)
Pipe	Flange Type/Wafer Type PFA/Polyurethane Rubber/Natural Soft Rubber/EPDM Rubber lining	Stainless steel-JIS SUS304 (AISI 304 SS/EN 1.4301 equivalent)
	Wafer Type Ceramics lining (available with 150 mm (6.0 in.), 200 mm (8.0 in.))	Alumina ceramics (99.9%)
Terminal Box (Remote Flowtube)		Aluminum alloy

T05.EPS

Wetted Part Material:

Lining:

- Fluorocarbon PFA*1 lining
- Polyurethane Rubber lining
- Natural Soft Rubber lining*2
- EPDM Rubber lining*3
- Alumina ceramics lining

- *1: PFA is FDA (U.S. Food and Drug Administration) approval material.
- *2: Natural soft rubber is a material which can reduce wear of the lining due to fluids mixed with slurries. If the concentration of mixed slurries is high, contact Yokogawa as necessary measures need to be taken separately for the electrodes.
- *3: EPDM rubber lining is superior in the ozone proof.

Electrode:

Stainless steel-JIS SUS316L (AISI 316L SS/EN 1.4404 equivalent), Hastelloy*1 C276 equivalent, Titanium, Tantalum, Platinum-Iridium, Tungsten Carbide, Platinum-Alumina cermet(only for ceramics lining)
 Note : For sanitary type, SUS316L only.

Grounding Ring/Grounding Electrode:



- Grounding Ring(plate type)
 Stainless steel-JIS SUS316 (AISI 316 SS/EN 1.4401 equivalent),
 Stainless steel-JIS SUS316L or ASTM 316L (AISI 316L SS/EN 1.4404 equivalent),
 Hastelloy*1 C276 equivalent, Titanium
- Grounding Electrode(electrode type)
 Fluorocarbon PFA lining + grounding electrode (Tantalum, Platinum-Iridium)

- *1: Hastelloy is a registered trademark of Haynes International Inc.
- *2: Available with sizes 2.5 to 200mm (0.1 to 8.0 in.), PFA and ceramics linings only. However, the permeable fluids (such as nitric acid, hydrofluoric acid, or sodium hydroxide at high temperature) are unusable.

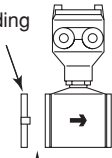
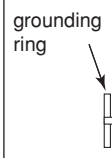
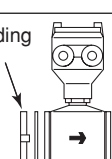
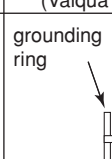
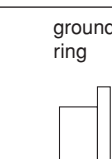
Gasket:

Use	General-Purpose Use / Submersible Type / Explosion proof Type	
Lining	PFA/Polyurethane Rubber/ Natural Soft Rubber/ EPDM Rubber	Ceramics
Standard	 grounding ring No gasket within Flowtube	 grounding ring Gasket within Flowtube
	Gasket Material (within Flowtube)	
	—	Fluororesin with ceramic fillers (Valqua #7020)
Optional code (GA, GC, GD, or GF)	 grounding ring Gasket within Flowtube	 grounding ring Gasket within Flowtube
	Gasket Material (within Flowtube)	
	GA: Fluororubber for PVC pipes (Viton®) GC: Acid-resistant fluororubber for PVC pipes (Viton®) GD: Alkali-resistant fluororubber for PVC pipes (Viton®) GF*1: Fluororesin with alkali-resistant carbons for metal pipes *1: GF is applicable only for ceramics lining.	
Optional code (BCF, BSF, BCC, or BSC)	 grounding ring Flange of user's pipe Gasket for user's flange	
	Gasket Material (for user's flange)	
	BCF, BSF: PTFE-sheathed non-asbestos BCC, BSC: Chloroprene rubber	

T23-1.EPS

Use	Sanitary Type
Lining	PFA
Standard	 Adapter for clamp connection
	 Adapter for union connection
	 Adapter for butt weld connection Gasket within Flowtube
	Gasket Material (within Flowtube)
	EPDM (ethylene propylene) rubber
Optional code (GH)	GH: Silicone rubber

T23-2.EPS

Joints:

Lining	Ceramics Union Joints (size 10 mm or less)	
Standard		
	Materials for Union Joint	
	Process Connection Code GUW: Union Joint (weld joint)	Stainless steel (JIS SUS316L (ANSI 316L SS/EN 1.4404 equivalent))
Process Connection Code GUN, GUR: union joint (screw joint)		

Note: Contact Yokogawa office if PVC union joint is required.
T23-3.EPS

Use	Sanitary Type
Standard	
	Materials for Adapters (clamp, union, butt weld)
	Stainless steel-JIS SUS316L or SUSF316L (AISI 316L SS/EN 1.4404 equivalent or ANSI F316L SS/EN 1.4435 equivalent)

T23-4.EPS

O-Ring (Replaceable electrode type only):

Fluororubber (Part number : G9303SE)

Recommended Gaskets Between Flowtubes

And User's Flanges:

Gaskets Type

Use compressed non-asbestos fiber gaskets, PTFE-sheathed non-asbestos gaskets or gaskets which have equivalent elasticity.

For optional codes GA, GC, and GD, use rubber gaskets or others which have equivalent elasticity (such as PTFE-sheathed gaskets).

Gaskets Size

Be sure to choose a gasket with an inner and outer diameter that does not protrude inside the piping (refer to Subsection 3.3.5).

If the inner diameter of the gasket is too large, or outer diameter of the gasket is too small, fluid leakage may result.

Electrode Construction:

Non-replaceable Electrode Type

General-Purpose Use/Submersible Type/Explosion proof Type:

PFA, Polyurethane Rubber lining:
External insertion type

Natural Soft Rubber, EPDM Rubber lining:

Internal insertion type

Ceramics lining: Integral type

Sanitary Type: Internal insertion type

Replaceable Electrode Type

Electrode parts can be put into unit to facilitate replacement or mounting at customer site.

The optional dedicated tool (F9807SK) is required.

Replaceable electrodes are available for the following:

AXF standard:

Use	Process Connection	Available Size	Lining	Electrode Material
General-Purpose Use	Wafer	25 to 300 mm (1.0 to 12 in.)	PFA/ Polyurethane Rubber	JIS SUS316L (AISI 316L SS/EN 1.4404 equivalent) ^(*)
	Flange	25 to 400 mm (1.0 to 16 in.)		

T06.EPS

Replacement model for earlier ADMAG or ADMAG AE:

Use	Process Connection	Available Size	Lining	Electrode Material
General-Purpose Use	Flange	150 to 250 mm (6.0 to 10 in.)	PFA/ Polyurethane Rubber	JIS SUS316L (AISI 316L SS/EN 1.4404 equivalent) ^(*)

T07.EPS

*1: If any other electrode materials are required, please contact Yokogawa office.

Mounting/Shapes (Remote Flowtube):

- Electrical Connection: ANSI 1/2 NPT female
ISO M20 × 1.5 female
JIS G1/2 female
- Direction of Electrical Connection: The direction can be changed even after delivery.
Note: In case of submersible types, an optional code DHC, the direction can not be changed after delivery.
- Terminal Connection at Terminal Box: M4 size screw

Grounding:

Grounding resistance 100 Ω or less

* In case of explosion proof type except TIIS, follow the domestic electrical requirements as regulated in each country.

* In case of TIIS Flameproof type, refer to description of "HAZARDOUS AREA CLASSIFICATION".

Combined Converter:

- AXF remote flowtube can be combined with AXFA11 Converter or AXFA14 Converter. For ATEX, IECEx or TIIS certified AXF remote flowtube, it is only approved to be combined with AXFA14 converter.
- If a combined converter is changed from AXFA11 to AXFA14 or vice versa, a new meter factor must be adjusted by flow calibrations.
- In case that size 250 mm (10 in.) or larger is used in low conductivity or high concentration slurries, please use the AXFA11 Converter.
- Maximum Cable Length:
Combination of AXF remote Flowtube and AXFA11:
up to 200 m (660 ft)
Combination of AXF remote Flowtube and AXFA14:
up to 100 m (330 ft)

HAZARDOUS AREA CLASSIFICATION

Refer to Chapter 8.

STANDARD PERFORMANCE

Accuracy

Note: The accuracy of a product before shipment is defined as totalized value at the result of calibration test in our water actual flow test facility. Calibrated conditions in our water actual test facility are as follows:

Fluid temperature; 20 ± 10°C
 Ambient temperature; 20 ± 5°C
 Length of straight runs; 10 D or more on the upstream side; 5 D or more on the downstream side

Reference conditions; Similar to BS EN29104 (1993); ISO 9104 (1991)

Pulse Output:

PFA/Ceramics Lining;

Size mm (in.)	Flow Velocity V m/s (ft/s)	Standard Accuracy ^(*) (Calibration code B)	Flow Velocity V m/s (ft/s)	High Grade Accuracy (Calibration code C)
2.5 (0.1) to 15 (0.5)	V < 0.3 (1)	±1.0 mm/s	—	—
	0.3 ≤ V ≤ 10 (1) (33)	±0.35% of Rate		
25 (1.0) to 200 (8.0)	V < 0.15 (0.5)	±0.5 mm/s	V < 0.15 (0.5)	±0.5 mm/s
	0.15 ≤ V ≤ 10 (0.5) (33)	±0.35% of Rate	0.15 ≤ V < 1 (0.5) (3.3)	±0.18% of Rate ±0.2mm/s
			1 ≤ V ≤ 10 (3.3) (33)	±0.2% of Rate
250 (10) to 400 (16)	V < 0.15 (0.5)	±0.5 mm/s	—	—
	0.15 ≤ V ≤ 10 (0.5) (33)	±0.35% of Rate		

*: For enhanced dual frequency excitation (Option code HF2) add ±1 mm/s to the standard accuracy.

Size 2.5 mm (0.1 in.) to 15 mm (0.5 in.)

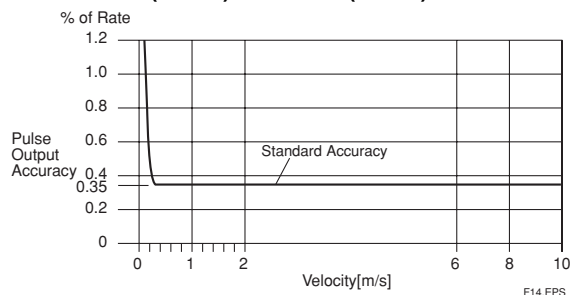

Size 25 mm (1.0 in.) to 400 mm (16 in.)

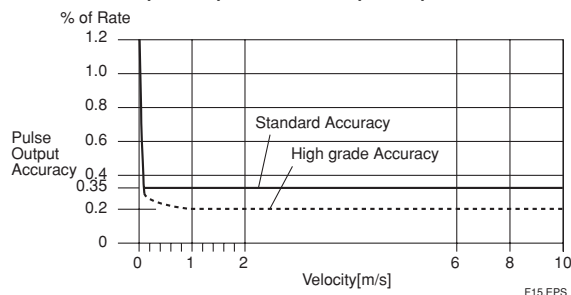

Polyurethane Rubber /Natural Soft Rubber / EPDM Rubber Lining:

Size mm (in.)	Flow Velocity V m/s (ft/s)	Standard Accuracy ^(*) (Calibration code B)
25 (1.0) to 400 (16)	V < 0.3 (1.0)	±1.0 mm/s
	0.3 ≤ V ≤ 10 (1.0) (33)	±0.35% of Rate

*: For enhanced dual frequency excitation (Option code HF2) add ±1 mm/s to the standard accuracy.

Size 25 mm (1.0 in.) to 400 mm (16 in.)

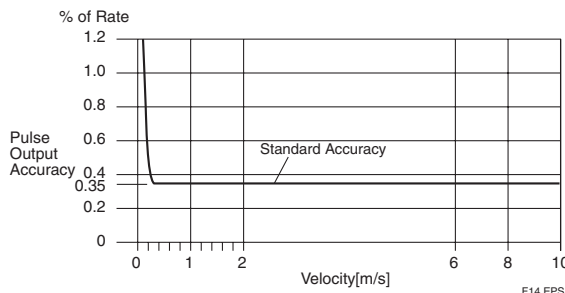

Current Output “◇”: Pulse output accuracy plus ±0.05% of Span

Repeatability:

±0.1% of Rate (V ≥ 1 m/s (3.3 ft/s))
 ±0.05% of Rate ±0.5 mm/s (V < 1 m/s (3.3 ft/s))

Maximum Power Consumption:

Integral Flowmeter: 12W
 Remote Flowtube: Combined with AXFA11: 20W
 Combined with AXFA14: 12W

Note: The power consumption is the same as above regardless of the communication type.

Insulation Resistance (*1):

Integral Flowmeter:

Between power supply terminals and ground terminal : 100MΩ at 500V DC
 Between power supply terminals and input/output terminals : 100MΩ at 500V DC
 Between ground terminal and input/output terminals : 20MΩ at 100V DC
 Between input/output terminals : 20MΩ at 100V DC

Remote Flowtube:

Between excitation current terminal and signal /common terminals : 100MΩ at 500V DC
 Between signal terminals : 100MΩ at 500V DC
 Between signal terminals and common terminal (C) : 100MΩ at 500V DC

Withstand Voltage (*1):

Integral Flowmeter

Between power supply terminals and ground terminal : 1400V AC for 2 seconds
 Between power supply terminals and input/output terminals : 1400V AC for 2 seconds

Remote Flowtube (optional code JF3, KF21, CF1, and SF21)

Between excitation current terminal and ground terminal : 1500V AC for 1 minute
 Between signal terminals and ground terminal : 1500V AC for 1 minute
 Between signal terminals and excitation current terminal : 2000V AC for 1 minute

Remote Flowtube (optional code FF1)

Between signal terminals and ground terminal : 500V AC for 1 minute or 600V AC for 1 second
 Between signal terminals and excitation current terminal : 2000V AC for 1 minute or 2400V AC for 1 second.

Remote Flowtube (optional code WT1)

Between excitation current terminal and ground terminal : 1000V AC for 1 minute

Remote Flowtube (optional code WT2)

Between excitation current terminal and ground terminal : 1500V AC for 1 minute
 Between signal terminals and excitation current terminal : 1500V AC for 1 minute

**CAUTION**

- *1: When performing the Insulation Resistance Test or the Withstand Voltage Test, please obey the following caution.
- Following the relevant test, wait for more than 10 minutes after the power supply has been turned off before removing the cover.
 - Remove all wires from terminals before testing.
 - When the power terminal has a lighting protector (optional code A), remove the short bar at the ground terminal.
 - After testing, be sure to discharge by using a resistance and return all wires and the short bar to its correct position.
 - Screws must be tightened to a torque of 1.18 N-m or more.
 - After closing the cover, the power supply can be restored.

CE Marking:

CE marking is affixed on the name plate except for models with any of the following specifications.

- Suffix Code (Process Connection): CS1, CS2
- Optional Code: FF1, CF1, SF21, JF3

Safety Requirement Standards:

EN61010-1

EN61010-2-030

- Altitude at installation site: Max. 2000 m above sea level
- Installation category based on IEC1010: Overvoltage category II ("II" applies to electrical equipment which is supplied from the fixed installation like distribution board.)
- Pollution degree based on IEC1010: Pollution degree 2 ("Pollution degree" describes the degree to which a solid, liquid, or gas which deteriorates dielectric strength or surface resistivity is adhering. "2" applies to a normal indoor atmosphere.)

EMC Conformity Standards:

EN61326-1 Class A, Table 2 (For use in industrial locations)

EN61326-2-3

EN61326-2-5 (for FOUNDATION fieldbus/PROFIBUS only)

EN61000-3-2 ClassA

EN61000-3-3

- Performance Specification during immunity test
 Flowrate output: Output fluctuation within $\pm 5\%$ of default (1m/s) span

**CAUTION**

This instrument is a class A product, and it is designed for use in the industrial environment.
 Please use this instrument in the industrial environment only.

■ NORMAL OPERATING CONDITIONS**Ambient Temperature:** -40 to $+60^{\circ}\text{C}$ (-40 to $+140^{\circ}\text{F}$)

- *1: Minimum temperature should also be limited according to minimum fluid temperature of flow tube's specification.
 Refer to description of "Fluid Temperature and Pressure".
- *2: Indicator's operating range (integral flowmeter): -20 to $+60^{\circ}\text{C}$ (-4 to $+140^{\circ}\text{F}$)
- *3: Maximum temperature should be $+50^{\circ}\text{C}$ ($+122^{\circ}\text{F}$) in the case of power supply code 2 (integral flowmeter).

Ambient Humidity: 0 to 100%

Lengthy continuous operation at 95% or more is not recommended.

Power Supply (integral flowmeter):**Power supply code 1:**

- AC specifications
 Rated power supply: 100 to 240 V AC, 50/60 Hz
 (Operating voltage range: 80 to 264 V AC)
- DC specifications
 Rated power supply: 100 to 120 V DC
 (Operating voltage range: 90 to 130 V DC)

Power supply code 2:

- AC specifications
 Rated power supply: 24 V AC, 50/60 Hz
 (Operating voltage range: 20.4 to 28.8 V AC)
- DC specifications
 Rated power supply: 24 V DC
 (Operating voltage range: 20.4 to 28.8 V DC)

Supply Voltage and Cable Length for Power Supply Code 2

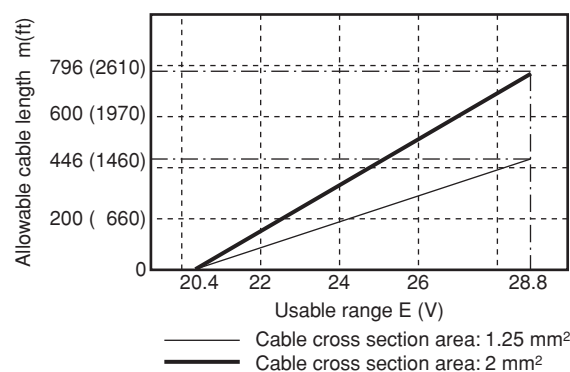

F01.EPS

Fluid Conductivity:

- Size 2.5 to 10 mm (0.1 to 0.4 in.): $5 \mu\text{S}/\text{cm}$ or larger
 - Size 15 to 125 mm (0.5 to 5 in.): $1 \mu\text{S}/\text{cm}$ or larger
 - Size 150 to 400 mm (6 to 16 in.): $3 \mu\text{S}/\text{cm}$ or larger
- Note: Fluids with large flow noise (pure water, fluid with low conductivity and low viscosity such as alcohol) cause the output fluctuation. Be careful that it affects the flow rate measurement. It is recommended to use the CA capacitance magnetic flowmeter.

Cable Length and Liquid Conductivity (Remote Flowtube):

Size 2.5 to 10 mm (0.1 to 0.4 in.)

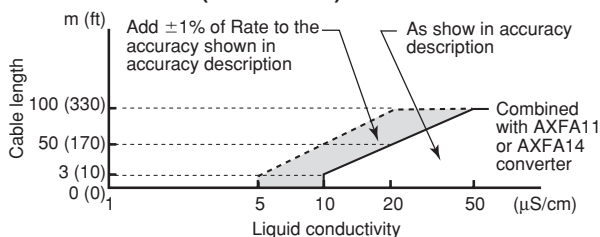

Size 15 to 125 mm (0.5 to 5.0 in.)

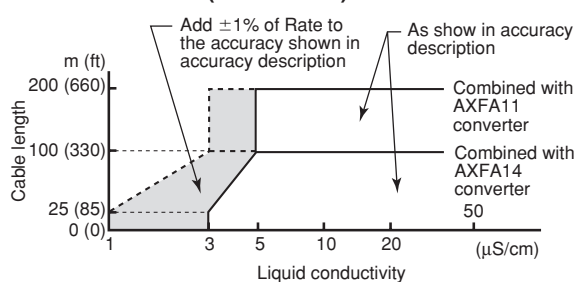

Size 150 to 400 mm (6.0 to 16 in.)

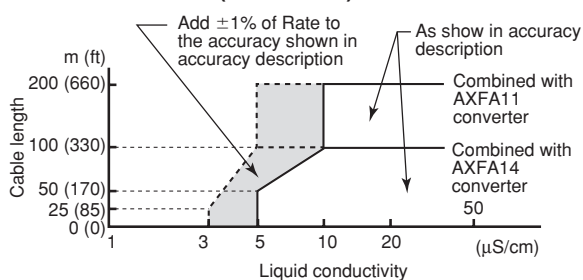

F03.EPS

Note: In case that size 250 or 300 mm (10 or 12 in.) is used for high conductivity fluid (ex. caustic soda, seawater), please use the flange type.

Measurable Flow Rate Range:

SI Units (Size: mm, Flow rate: m³/h)

Size (mm)	0 to Min. Span Flow Rate (0.1 m/s)	0 to Max. Span Flow Rate (10 m/s)
2.5	0 to 0.0018 m³/h	0 to 0.1767 m³/h
5	0 to 0.0071	0 to 0.7068
10	0 to 0.0283	0 to 2.8274
15	0 to 0.0637	0 to 6.361
25	0 to 0.1768	0 to 17.671
32	0 to 0.2896	0 to 28.952
40	0 to 0.4524	0 to 45.23
50	0 to 0.7069	0 to 70.68
65	0 to 1.1946	0 to 119.45
80	0 to 1.8096	0 to 180.95
100	0 to 2.8275	0 to 282.74
125	0 to 4.418	0 to 441.7
150	0 to 6.362	0 to 636.1
200	0 to 11.310	0 to 1,130.9
250	0 to 17.672	0 to 1,767.1
300	0 to 25.447	0 to 2,544.6
350	0 to 34.64	0 to 3,463
400	0 to 45.24	0 to 4,523

T11.EPS

English Units (Size: in., Flow rate: GPM)

Size (in.)	0 to Min. Span Flow Rate (0.33ft/s)	0 to Max. Span Flow Rate (33ft/s)
0.1	0 to 0.0078 GPM	0 to 0.7780 GPM
0.2	0 to 0.0312	0 to 3.112
0.4	0 to 0.1245	0 to 12.44
0.5	0 to 0.1946	0 to 19.45
1.0	0 to 0.7781	0 to 77.80
1.25	0 to 1.216	0 to 121.5
1.5	0 to 1.751	0 to 175.0
2.0	0 to 3.113	0 to 311.2
2.5	0 to 4.863	0 to 486.2
3.0	0 to 7.003	0 to 700.2
4.0	0 to 12.45	0 to 1,244
5.0	0 to 19.46	0 to 1,945
6.0	0 to 28.01	0 to 2,800
8.0	0 to 49.80	0 to 4,979
10	0 to 77.81	0 to 7,780
12	0 to 112.1	0 to 11,203
14	0 to 152.5	0 to 15,249
16	0 to 199.2	0 to 19,918

T24.EPS

Fluid Temperature and Pressure:

The following figures show maximum allowable fluid pressure for the flowtube. Further fluid pressure should also be limited according to flange rating.

For fluid temperature of the explosion proof type, refer to descriptions of "HAZARDOUS AREA CLASSIFICATION".

PFA Lining (*1)

General-Purpose Use, Submersible Type, Explosion proof Type, Remote Flowtube (electrode structure code 1: Non-replaceable electrode)

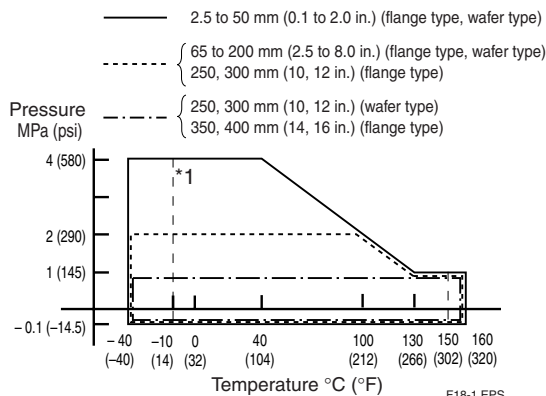

F18-1.EPS

General-Purpose Use and Explosion proof Type, Integral Flowmeter (electrode structure code 1: Non-replaceable electrode)

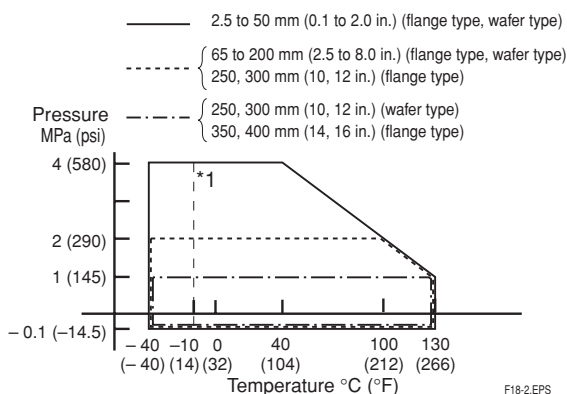

F18-2.EPS

*1: For wafer types of 32 mm to 300 mm (1.25 to 12 in.), or for carbon steel flange types (process connection code: C**), the minimum temperature is -10°C (14°F).

*2: For fluid temperature of the explosion proof type, refer to descriptions of "HAZARDOUS AREA CLASSIFICATION".

General-Purpose Use, Remote Flowtube (electrode structure code 2: replaceable electrode)

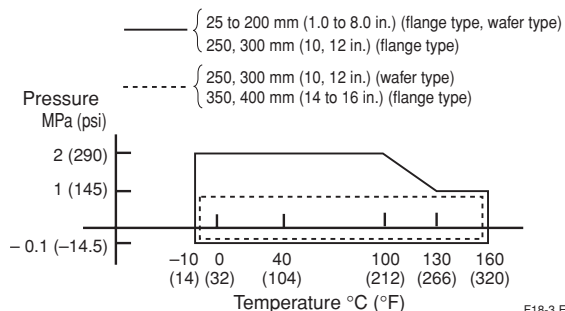

F18-3.EPS

General-Purpose Use, Integral Flowmeter (electrode structure code 2: replaceable electrode)

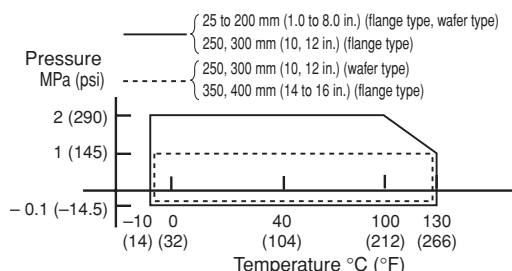

F18-4.EPS

Note: For replaceable electrodes for fluid temperatures of -10°C (14°F) or less, please contact Yokogawa office.

Sanitary Type (electrode structure code 1: Non-replaceable electrode)

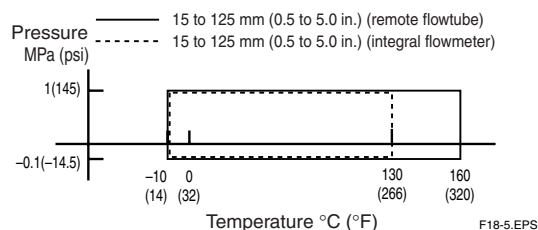

F18-5.EPS

Note: In case of 120 to 160°C (248 to 320°F) of fluid temperature, please select optional code GH.

Ceramics Lining

General-Purpose Use and Explosion proof Type, Remote Flowtube (electrode structure code 1: Non-replaceable electrode)

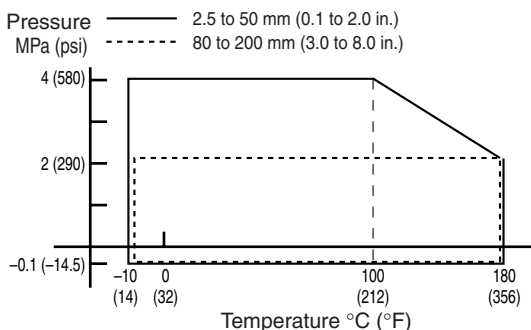

F19-1.EPS

General-Purpose Use and Explosion proof Type, Integral flowmeter (electrode structure code 1: Non-replaceable electrode)

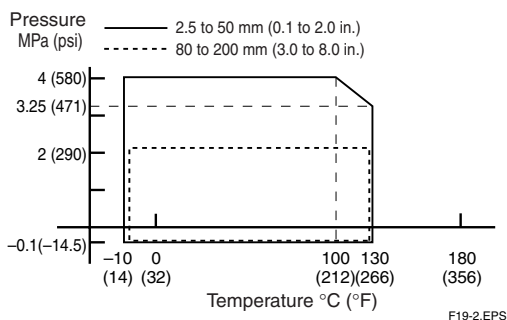

*1: For fluid temperature of the explosion proof type, refer to descriptions of "HAZARDOUS AREA CLASSIFICATION".

Polyurethane Rubber Lining

General-Purpose Use and Submersible Type, Remote Flowtube (electrode structure code 1: Non-replaceable electrode)

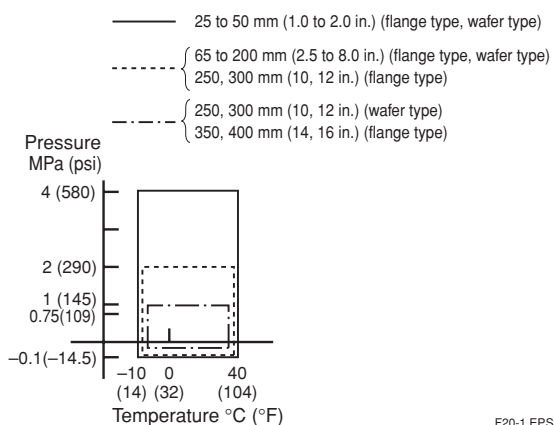

General-Purpose Use, Integral Flowmeter (electrode structure code 2: replaceable electrode)

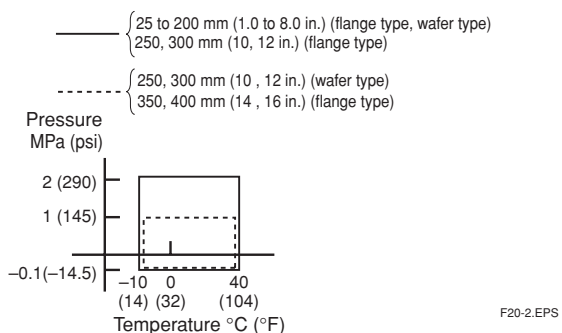

Natural Soft Rubber Lining

General-Purpose Use and Submersible Type, Remote Flowtube (electrode structure code 1: Non-replaceable electrode)

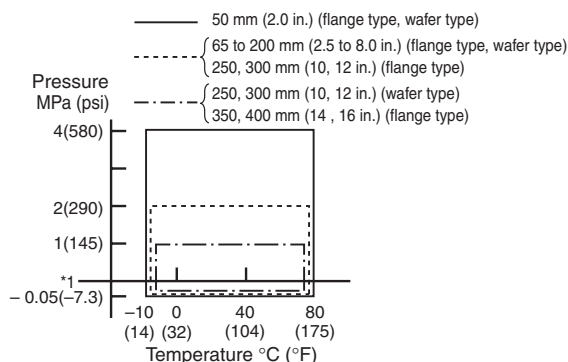

EPDM Rubber Lining

General-Purpose Use and Submersible Type, Remote Flowtube (electrode structure code 1: Non-replaceable electrode)

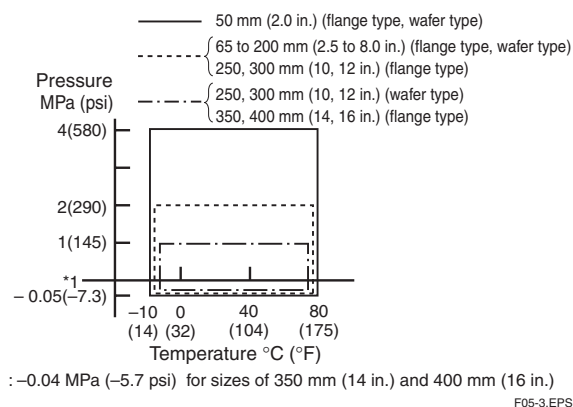

Reasonable Figure for Thermal Shock of Ceramics Lining:

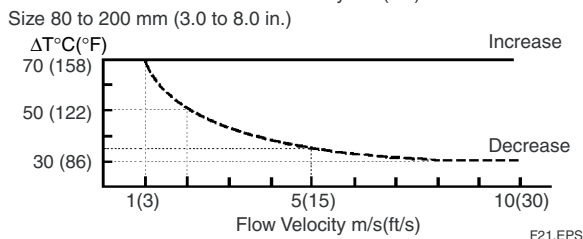
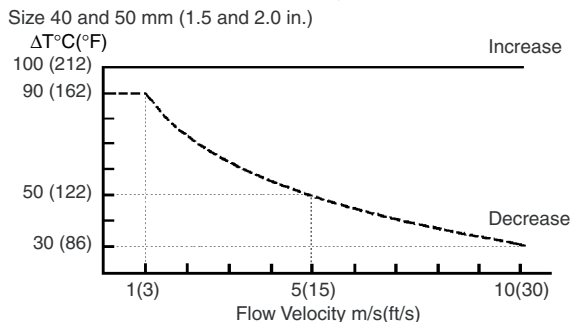
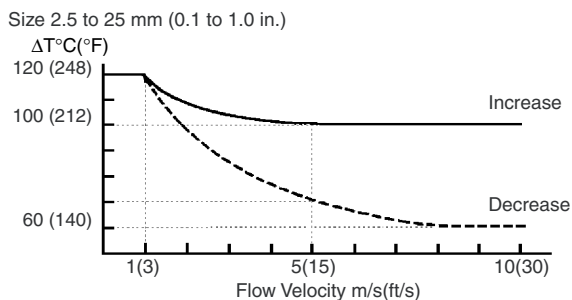

“Decrease” means that the temperature of a measured fluid drops rapidly, “Increase” means that the temperature rises rapidly. The maximum allowable ranges in both cases are indicated by the curves shown in the diagrams, with the solid line indicating the maximum increase, and the broken line the maximum decrease.

ΔT: Change in temperature of measured fluid in one second

Flow velocity: flow velocity of the measured fluid

Allowable Conditions for Cleaning Sanitary Type Linings

Steam or hot water cleaning: Max.temp.= 150 °C (302°F), time= 60 minutes or less

Vibration Conditions:

Level of vibration in conformity with IEC 60068-2-6 (SAMA 31.1-1980)

- Integral Flowmeter: 9.8 m/s² or less (frequency of 500 Hz or less)

- Remote Flowtube: 19.6 m/s² or less (frequency of 500 Hz or less)

Note: Avoid locations with much vibration (where the pipe vibration frequency is 500 Hz or more), which may cause damage to the equipment.

ACCESSORIES

- Centering device (wafer type only): 1 pc.
- Hexagonal wrench: 2 pcs.

TERMINAL CONFIGURATION AND TERMINAL WIRING

● Integral Flowmeter “◇”

Terminal configuration

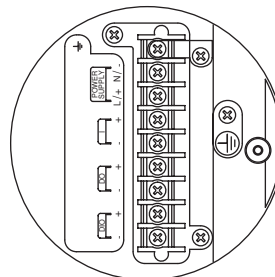

Terminal wiring

Terminal Symbols	Description
	Functional grounding
N/- L/+	Power supply
I+ I-	Current output 4 to 20mA DC
DO+ DO-	Pulse output/Alarm output/ Status output
DIO+ DIO-	Alarm output/Status output Status input
	Protective grounding (Outside of the terminal)

F41.EPS

● Remote Flowtube

Terminal configuration

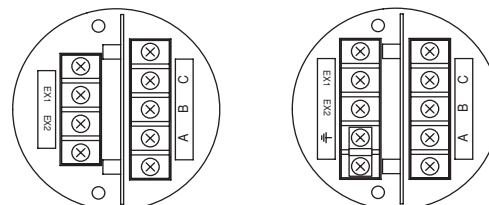

For other than Explosion proof type

For Explosion proof type

Terminal wiring

Terminal Symbols	Description
A B C	Flow signal output
EX1 EX2	Excitation current input
	Functional grounding (Only for explosion proof type)
	Protective grounding (Outside of the terminal)

F42.EPS

Note: When submersible type or optional code DHC is selected, waterproof glands and a 30m long cable are attached.

MODEL AND SUFFIX CODE

AXF STANDARD (Wafer Type)

General-purpose Use/Submersible Type/Explosion proof Type, PFA/Polyurethane Rubber/Natural Soft Rubber/EPDM Rubber Lining

Model	Suffix Code	Description	Applicable Model
AXF002	Size 2.5 mm (0.1 in.) Integral Flowmeter/Remote Flowtube	
AXF005	Size 5 mm (0.2 in.) Integral Flowmeter/Remote Flowtube	
AXF010	Size 10 mm (0.4 in.) Integral Flowmeter/Remote Flowtube	
AXF015	Size 15 mm (0.5 in.) Integral Flowmeter/Remote Flowtube	
AXF025	Size 25 mm (1.0 in.) Integral Flowmeter/Remote Flowtube	
AXF032	Size 32 mm (1.25 in.) Integral Flowmeter/Remote Flowtube	
AXF040	Size 40 mm (1.5 in.) Integral Flowmeter/Remote Flowtube	
AXF050	Size 50 mm (2.0 in.) Integral Flowmeter/Remote Flowtube	
AXF065	Size 65 mm (2.5 in.) Integral Flowmeter/Remote Flowtube	
AXF080	Size 80 mm (3.0 in.) Integral Flowmeter/Remote Flowtube	
AXF100	Size 100 mm (4.0 in.) Integral Flowmeter/Remote Flowtube	
AXF125	Size 125 mm (5.0 in.) Integral Flowmeter/Remote Flowtube	
AXF150	Size 150 mm (6.0 in.) Integral Flowmeter/Remote Flowtube	
AXF200	Size 200 mm (8.0 in.) Integral Flowmeter/Remote Flowtube	
AXF250	Size 250 mm (10 in.) Integral Flowmeter/Remote Flowtube	
AXF300	Size 300 mm (12 in.) Integral Flowmeter/Remote Flowtube	
Use	G	General-Purpose Use	Size 15 mm (0.5 in.) to 300 mm (12 in.) Remote Flowtube only PFA lining only
	W	Submersible Type	
	C	Explosion proof Type (*5)	
Converter, Output Signal and Communication	-D	Integral Flowmeter with 4 to 20mA DC Output and BRAIN Communication	
	-E	Integral Flowmeter with 4 to 20 mA DC Output and HART Communication	
	-F	Integral Flowmeter with Digital communication (FOUNDATION fieldbus protocol) (*9)	
	-G	Integral Flowmeter with Digital communication (PROFIBUS PA protocol) (*10)	
	-N	Remote Flowtube for Combined Use with AXFA11	
-P	Remote Flowtube for Combined Use with AXFA14 (*5)		
Power Supply	1	Integral Flowmeter, 100 V to 240 V AC or 100 to 120 V DC	
	2	Integral Flowmeter, 24V AC/DC	
	N	Remote Flowtube	
Lining (*8)	A	Fluorocarbon PFA	Size 25 mm (1.0 in.) to 300 mm (12 in.) Size 50 mm (2.0 in.) to 300 mm (12 in.) Size 50 mm (2.0 in.) to 300 mm (12 in.)
	U	Polyurethane Rubber	
	D	Natural Soft Rubber	
	G	EPDM Rubber	
Electrode Material (*8)	L	JIS SUS316L (AISI 316L SS/EN 1.4404 Equivalent)	PFA lining only
	P	Platinum-iridium	
	H	Hastelloy C276 Equivalent	PFA lining only
	T	Tantalum	
	V	Titanium	Size 15 mm (0.5 in.) to 300 mm (12 in.), PFA/Polyurethane Rubber lining only
	W	Tungsten Carbide	
Electrode Structure	1	Non-replaceable	General-Purpose use, Size 25 mm (1.0 in.) to 300 mm (12 in.), PFA/Polyurethane Rubber lining only Electrode Material: JIS SUS316L only
	2	Replaceable	
Grounding Ring and Grounding Electrode Material (*8)	N	None	Size 2.5 mm (0.1 in.) to 200 mm (8.0 in.), PFA lining only Size 2.5 mm (0.1 in.) to 200 mm (8.0 in.), PFA lining only
	S	JIS SUS316 (AISI 316 SS/EN 1.4401 Equivalent)	
	L	JIS SUS316L or ASTM 316L (AISI 316L SS/EN 1.4404 Equivalent)	
	P	Platinum-iridium	
	H	Hastelloy C276 Equivalent	
	T	Tantalum	
Process Connection (*3) (*11) (*13)	-AA1	ANSI Class 150 Wafer (*1)	Size 2.5 mm (0.1 in.) to 300 mm (12 in.) Size 2.5 mm (0.1 in.) to 200 mm (8.0 in.) Size 200 mm (8.0 in.) to 300 mm (12 in.) Size 65 mm (2.5 in.) to 300 mm (12 in.) Size 2.5 mm (0.1 in.) to 50 mm (2.0 in.) Size 2.5 mm (0.1 in.) to 300 mm (12 in.) Size 2.5 mm (0.1 in.) to 200 mm (8.0 in.) Size 80 mm (3.0 in.) to 300 mm (12 in.) Size 2.5 mm (0.1 in.) to 300 mm (12 in.) (*14) (*15) (*16)
	-AA2	ANSI Class 300 Wafer (*1)	
	-AD1	DIN PN 10 Wafer	
	-AD2	DIN PN 16 Wafer (*2)	
	-AD4	DIN PN 40 Wafer (*1) (*2)	
	-AJ1	JIS 10K Wafer (*1)	
	-AJ2	JIS 20K Wafer (*1)	
	-AG1	JIS F12 (JIS75M) Wafer	
	-AP1	JPI Class 150 Wafer (*1)	
	Lay Length	1	
Electrical Connection (*6)	-0	JIS G1/2 female	Not available for Submersible Type Not available for Submersible Type
	-2	ANSI 1/2 NPT female	
	-4	ISO M20×1.5 female	
Indicator (*4) (*7)	1	Integral Flowmeter with indicator (Horizontal)	
	2	Integral Flowmeter with indicator (Vertical)	
	N	Integral Flowmeter without indicator /Remote Flowtube	
Calibration	B	Standard	Size 25 mm (1.0 in.) to 200 mm (8.0 in.), PFA lining only
	C	High Grade (*12)	
Option	<input type="checkbox"/>	Optional code (See the Table of Optional Specifications)	

T15.EPS

- *1: For a wafer type of 2.5 to 10 mm (0.1 to 0.4 in.), prepare 15 mm (0.5 in.) diameter nominal flanges on the process pipe side.
(Process connection codes: AA1, AA2, AD4, AJ1, AJ2 and AP1)
 - *2: Even when DIN PN10 or 16 is required for a model of size 2.5 to 50 mm (0.1 to 2.0 in.), select PN40 (Process connection code: AD4) because there is no difference in the dimensions of the mating faces.
Even when DIN PN10 is required for a model of size 65 to 150 mm (2.5 to 6.0 in.), select PN16 (Process connection code: AD2) because there is no difference in the dimensions of the mating faces.
 - *3: Mating dimensions are based on standards as follow:
ANSI: ASME B 16.5, DIN: DIN 2501, JIS: JIS B 2220 and JIS G 3443-2, JPI: JPI-7S-15-1999
 - *4: N shall be always selected for remote flowtubes
-
- *5: In the case of an integral flowmeter, select from among the figures at the right:
 - *5: For explosion proof types, specify types of explosion proof certification using the optional codes. For ATEX, IECEx or TIIS certified AXF remote flowtube, select "Combined Use with AXFA14" (Converter, output signal and communication code: -P). For the TIIS flameproof type with wiring using a flameproof packing adapter, select optional code G12 or G11. Available only for JIS G1/2 female electrical connections.
 - *6: For explosion proof types, JIS G1/2 female electrical connection is available only for TIIS flameproof type.
 - *7: In case of integral flowmeters of the TIIS flameproof type, select "with indicator"(Indicator code: 1 or 2).
 - *8: Δ Users must consider the characteristics of selected wetted parts material and influence of process fluids.
The use of inappropriate materials can result in the leakage of corrosive process fluids and cause injury to personnel and/or damage to plant facilities. It is also possible that the instrument itself can be damaged and that fragments from the instrument can contaminate the user's process fluids.
Be very careful with highly corrosive process fluids such as hydrochloric acid, sulfuric acid, hydrogen sulfide, sodium hypochlorite, and high-temperature steam (150°C [302°F] or above). Contact Yokogawa for detailed information of the wetted parts material.
 - *9: For FOUNDATION fieldbus protocol, refer to IM 01E20F02-01E
 - *10: For PROFIBUS PA protocol, refer to IM 01E20F12-01E.
 - *11: Allowable fluid pressure should also be limited according to fluid temperature and pressure.
 - *12: In the case of calibration code C in remote type, please order a combination of flowtube and converter.
 - *13: For material specifications, refer to description of "Flowtube Material".
 - *14: Available only for PFA lining and non-replaceable electrode.
 - *15: Not available for 32 mm (1.25 in.), 65 mm (2.5 in.) and 125 mm (5.0 in.).
 - *16: For 2.5 mm (0.1 in.) to 200 mm (8.0 in.), explosion proof type is available only for TIIS flameproof type.
For Size 250 mm (10 in.) to 300 mm (12 in.), explosion proof type is not available.

AXF STANDARD (Wafer /Union Joint Type)

General-purpose Use/Explosion proof Type, Ceramics Lining

Model	Suffix Code	Description	Applicable Model
AXF002	Size 2.5 mm (0.1 in.) Integral Flowmeter/Remote Flowtube	
AXF005	Size 5 mm (0.2 in.) Integral Flowmeter/Remote Flowtube	
AXF010	Size 10 mm (0.4 in.) Integral Flowmeter/Remote Flowtube	
AXF015	Size 15 mm (0.5 in.) Integral Flowmeter/Remote Flowtube	
AXF025	Size 25 mm (1.0 in.) Integral Flowmeter/Remote Flowtube	
AXF040	Size 40 mm (1.5 in.) Integral Flowmeter/Remote Flowtube	
AXF050	Size 50 mm (2.0 in.) Integral Flowmeter/Remote Flowtube	
AXF080	Size 80 mm (3.0 in.) Integral Flowmeter/Remote Flowtube	
AXF100	Size 100 mm (4.0 in.) Integral Flowmeter/Remote Flowtube	
AXF150	Size 150 mm (6.0 in.) Integral Flowmeter/Remote Flowtube	
AXF200	Size 200 mm (8.0 in.) Integral Flowmeter/Remote Flowtube	
Use	G	General-Purpose Use	
	C	Explosion proof Type (*5)	
Converter, Output Signal and Communication	-D	Integral Flowmeter with 4 to 20 mA DC Output and BRAIN Communication	
	-E	Integral Flowmeter with 4 to 20 mA DC Output and HART Communication	
	-F	Integral Flowmeter with Digital communication (FOUNDATION fieldbus protocol) (*9)	
	-G	Integral Flowmeter with Digital communication (PROFIBUS PA protocol) (*10)	
	-N	Remote Flowtube for Combined use with AXFA11	
	-P	Remote Flowtube for Combined use with AXFA14 (*5)	
Power Supply	1	Integral Flowmeter, 100 V to 240 V AC or 100 to 120 V DC	
	2	Integral Flowmeter, 24 V AC/DC	
	N	Remote Flowtube	
Lining (*8)	C	Ceramics	
Electrode Material (*8)	E	Platinum-alumina Cermet	
Electrode Structure	1	Non-replaceable	
Grounding Ring and Grounding Electrode Material (*8)	N	None	Size 2.5 mm (0.1 in.) to 200 mm (8.0 in.)
	S	JIS SUS316 (AISI 316 SS/EN 1.4401 Equivalent)	Size 15 mm (0.5 in.) to 200 mm (8.0 in.)
	L	JIS SUS316L or ASTM 316L (AISI 316L SS/EN 1.4404 Equivalent)	Size 15 mm (0.5 in.) to 200 mm (8.0 in.)
	P	Platinum-iridium	Size 15 mm (0.5 in.) to 200 mm (8.0 in.)
	H	Hastelloy C276 Equivalent	Size 15 mm (0.5 in.) to 200 mm (8.0 in.)
	T	Tantalum	Size 15 mm (0.5 in.) to 200 mm (8.0 in.)
	V	Titanium	Size 15 mm (0.5 in.) to 200 mm (8.0 in.)
Process Connection (*2) (*11) (*13)	-AA1	ANSI Class 150 Wafer	Size 15 mm (0.5 in.) to 200 mm (8.0 in.)
	-AA2	ANSI Class 300 Wafer	Size 15 mm (0.5 in.) to 200 mm (8.0 in.)
	-AD1	DIN PN 10 Wafer	Size 200 mm (8.0 in.) only
	-AD2	DIN PN 16 Wafer (*1)	Size 80 mm (3.0 in.) to 200 mm (8.0 in.)
	-AD4	DIN PN 40 Wafer (*1)	Size 15 mm (0.5 in.) to 50 mm (2.0 in.)
	-AJ1	JIS 10K Wafer	Size 15 mm (0.5 in.) to 200 mm (8.0 in.)
	-AJ2	JIS 20K Wafer	Size 15 mm (0.5 in.) to 200 mm (8.0 in.)
	-AG1	JIS F12 (JIS75M) Wafer	Size 80 mm (3.0 in.) to 200 mm (8.0 in.)
	-GUW	Union Joint (Weld Joint) (*8)	Size 2.5 mm (0.1 in.) to 10 mm (0.4 in.)
	-GUN	Union Joint (1/4NPT Male for 2.5 or 5 mm dia.: 3/8NPT Male for 10 mm dia.) (*8)	Size 2.5 mm (0.1 in.) to 10 mm (0.4 in.)
	-GUR	Union Joint (R1/4 Male for 2.5 or 5 mm dia.: R3/8 Male for 10 mm dia.) (*8)	Size 2.5 mm (0.1 in.) to 10 mm (0.4 in.)
Lay Length (*3)	1	Standard	
Electrical Connection (*6)	-0	JIS G1/2 female	
	-2	ANSI 1/2 NPT female	
	-4	ISO M20×1.5 female	
Indicator (*4) (*7)	1	Integral Flowmeter with indicator (Horizontal)	
	2	Integral Flowmeter with indicator (Vertical)	
	N	Integral Flowmeter without indicator /Remote Flowtube	
Calibration	B	Standard	
	C	High Grade (*12)	Size 25 mm (1.0 in.) to 200mm (8.0 in.)
Option	/□	Optional code (See the Table of Optional Specifications)	

T16.EPS

- *1: Even when DIN PN10 or 16 is required for a model of size 2.5 to 50 mm (0.1 to 2.0 in.), select PN40 (Process connection code : AD4) because there is no difference in the dimensions of the mating faces.
Even when DIN PN10 is required for a model of size 65 to 150 mm (2.5 to 6.0 in.), select PN16 (Process connection code : AD2) because there is no difference in the dimensions of the mating faces.
- *2: Mating dimensions are based on standards as follow:
ANSI:ASME B 16.5, DIN: DIN 2501, JIS:JIS B 2220 and JIS G 3443-2
- *3: AXF standard lay length dimension for ceramics linings are the same as those for ADMAG ceramics linings.
- *4: N shall be always selected for remote flowtubes
In the case of an integral flowmeter, select from among the figures at the right:
- *5: For explosion proof types, specify types of explosion proof certification using the optional codes. For ATEX, IECEx or TIIS certified AXF remote flowtube, select "Combined Use with AXFA14" (Converter, output signal and communication code: -P). For the TIIS flameproof type with wiring using a flameproof packing adapter, select optional code G12 or G11. Available only for JIS G1/2 female electrical connections.
- *6: For explosion proof types, JIS G1/2 female electrical connection is available only for TIIS flameproof type.
- *7: In case of integral flowmeters of the TIIS flameproof type, select "with indicator"(Indicator code: 1 or 2).
- *8: Δ Users must consider the characteristics of selected wetted parts material and influence of process fluids.
The use of inappropriate materials can result in the leakage of corrosive process fluids and cause injury to personnel and/or damage to plant facilities. It is also possible that the instrument itself can be damaged and that fragments from the instrument can contaminate the user's process fluids.
Be very careful with highly corrosive process fluids such as hydrochloric acid, sulfuric acid, hydrogen sulfide, sodium hypochlorite, and high-temperature steam (150°C [302°F] or above). Contact Yokogawa for detailed information of the wetted parts material.
- *9: For FOUNDATION fieldbus protocol, refer to IM 01E20F02-01E
*10: For PROFIBUS PA protocol, refer to IM 01E20F12-01E.
- *11: Allowable fluid pressure should also be limited according to fluid temperature and pressure.
- *12: In the case of calibration code C in remote type, please order a combination of flowtube and converter.
- *13: For material specifications, refer to description of "Flowtube Material".

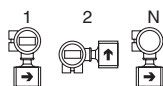

AXF STANDARD (Flange Type)

General-purpose Use/Submersible Type/Explosion proof Type, PFA/Polyurethane Rubber /Natural Soft Rubber/EPDM Rubber Lining

Model	Suffix Code	Description	Applicable Model
AXF002	Size 2.5 mm (0.1 in.) Integral Flowmeter/Remote Flowtube	
AXF005	Size 5 mm (0.2 in.) Integral Flowmeter/Remote Flowtube	
AXF010	Size 10 mm (0.4 in.) Integral Flowmeter/Remote Flowtube	
AXF015	Size 15 mm (0.5 in.) Integral Flowmeter/Remote Flowtube	
AXF025	Size 25 mm (1.0 in.) Integral Flowmeter/Remote Flowtube	
AXF032	Size 32 mm (1.25 in.) Integral Flowmeter/Remote Flowtube	
AXF040	Size 40 mm (1.5 in.) Integral Flowmeter/Remote Flowtube	
AXF050	Size 50 mm (2.0 in.) Integral Flowmeter/Remote Flowtube	
AXF065	Size 65 mm (2.5 in.) Integral Flowmeter/Remote Flowtube	
AXF080	Size 80 mm (3.0 in.) Integral Flowmeter/Remote Flowtube	
AXF100	Size 100 mm (4.0 in.) Integral Flowmeter/Remote Flowtube	
AXF125	Size 125 mm (5.0 in.) Integral Flowmeter/Remote Flowtube	
AXF150	Size 150 mm (6.0 in.) Integral Flowmeter/Remote Flowtube	
AXF200	Size 200 mm (8.0 in.) Integral Flowmeter/Remote Flowtube	
AXF250	Size 250 mm (10 in.) Integral Flowmeter/Remote Flowtube	
AXF300	Size 300 mm (12 in.) Integral Flowmeter/Remote Flowtube	
AXF350	Size 350 mm (14 in.) Integral Flowmeter/Remote Flowtube	
AXF400	Size 400 mm (16 in.) Integral Flowmeter/Remote Flowtube	
Use	G	General-Purpose Use	
	W	Submersible Type	Size 15 mm (0.5 in.) to 400 mm (16 in.), Remote Flowtube only
	C	Explosion proof Type (*6)	PFA lining only
Converter, Output Signal and Communication	-D	Integral Flowmeter with 4 to 20 mA DC Output and BRAIN Communication	
	-E	Integral Flowmeter with 4 to 20 mA DC Output and HART Communication	
	-F	Integral Flowmeter with Digital communication (FOUNDATION fieldbus protocol) (*10)	
	-G	Integral Flowmeter with Digital communication (PROFIBUS PA protocol) (*11)	
	-N	Remote Flowtube for Combined Use with AXFA11	
	-P	Remote Flowtube for Combined Use with AXFA14 (*6)	
Power Supply	1	Integral Flowmeter, 100 V to 240 V AC or 100 to 120 V DC	
	2	Integral Flowmeter, 24 V AC/DC	
	N	Remote Flowtube	
Lining (*9)	A	Fluorocarbon PFA	
	U	Polyurethane Rubber	Size 25 mm (1.0 in.) to 400 mm (16 in.)
	D	Natural Soft Rubber	Size 50 mm (2.0 in.) to 400 mm (16 in.)
	G	EPDM Rubber	Size 50 mm (2.0 in.) to 400 mm (16 in.)
Electrode Material (*9)	L	JIS SUS316L (AISI 316L SS/EN 1.4404 Equivalent)	
	P	Platinum-iridium	PFA lining only
	H	Hastelloy C276 Equivalent	
	T	Tantalum	PFA lining only
	V	Titanium	
	W	Tungsten Carbide	Size 15 mm (0.5 in.) to 400 mm (16 in.), PFA/Polyurethane Rubber lining only
Electrode Structure	1	Non-replaceable	
	2	Replaceable	General-Purpose use, Size 25 mm (1.0 in.) to 400 mm (16 in.) PFA/Polyurethane Rubber lining only Electrode Material: JIS SUS316L only
Grounding Ring and Grounding Electrode Material (*9)	N	None	
	S	JIS SUS316 (AISI 316 SS/EN 1.4401 Equivalent)	
	L	JIS SUS316L or ASTM 316L (AISI 316L SS/EN 1.4404 Equivalent)	
	P	Platinum-iridium	Size 2.5 mm (0.1 in.) to 200 mm (8.0 in.), PFA lining only
	H	Hastelloy C276 Equivalent	
	T	Tantalum	Size 2.5 mm (0.1 in.) to 200 mm (8.0 in.), PFA lining only
V	Titanium		
Process Connection (*4) (*12) (*14)	-BA1	ANSI Class 150 Flange (Stainless Steel) (*1)	Size 2.5 mm (0.1 in.) to 400 mm (16 in.)
	-BA2	ANSI Class 300 Flange (Stainless Steel) (*1)	Size 2.5 mm (0.1 in.) to 300 mm (12 in.)
	-BD1	DIN PN 10 Flange (Stainless Steel)	Size 200 mm (8.0 in.) to 400 mm (16 in.)
	-BD2	DIN PN 16 Flange (Stainless Steel) (*2)	Size 65 mm (2.5 in.) to 300 mm (12 in.)
	-BD4	DIN PN 40 Flange (Stainless Steel) (*1) (*2)	Size 2.5 mm (0.1 in.) to 50 mm (2.0 in.)
	-BJ1	JIS 10K Flange (Stainless Steel) (*1)	Size 2.5 mm (0.1 in.) to 400 mm (16 in.)
	-BJ2	JIS 20K Flange (Stainless Steel) (*1)	Size 2.5 mm (0.1 in.) to 300 mm (12 in.)
	-BG1	JIS F12 (JIS75M) Flange (Stainless Steel)	Size 80 mm (3.0 in.) to 400 mm (16 in.)
	-BP1	JPI Class 150 Flange (Stainless Steel) (*1)	Size 2.5 mm (0.1 in.) to 400 mm (16 in.) (*15) (*16) (*17)
	-CA1	ANSI Class 150 Flange (Carbon Steel)	Size 50 mm (2 in.) to 400 mm (16 in.) (*18)
	-CA2	ANSI Class 300 Flange (Carbon Steel)	Size 50 mm (2 in.) to 300 mm (12 in.) (*18)
	-CD1	DIN PN 10 Flange (Carbon Steel)	Size 200 mm (8.0 in.) to 400 mm (16 in.) (*18)
	-CD2	DIN PN 16 Flange (Carbon Steel) (*2)	Size 65 mm (2.5 in.) to 300 mm (12 in.) (*18)
	-CD4	DIN PN 40 Flange (Carbon Steel) (*2)	Size 50 mm (2.0 in.) only (*18)
	-CJ1	JIS 10K Flange (Carbon Steel)	Size 50 mm (2.0 in.) to 400 mm (16 in.) (*18)
	-CJ2	JIS 20K Flange (Carbon Steel)	Size 50 mm (2.0 in.) to 300 mm (12 in.) (*18)
	-CG1	JIS F12 (JIS75M) Flange (Carbon Steel)	Size 80 mm (3.0 in.) to 400 mm (16 in.) (*18)
	-CS1	AS Table D Flange (Carbon Steel)	Size 50 mm (2.0 in.) to 400 mm (16 in.) (*15) (*16) (*19)
	-CS2	AS Table E Flange (Carbon Steel)	Size 50 mm (2.0 in.) to 300 mm (12 in.) (*15) (*16) (*19)
	-DD4	DIN PN 40 Flange (Stainless Steel), DN10 (*2) (*3)	Size 2.5 mm (0.1 in.) to 10 mm (0.4 in.)
	-DJ1	JIS 10K Flange (Stainless Steel), 10 mm Diameter Nominal (*3)	Size 2.5 mm (0.1 in.) to 10 mm (0.4 in.)
	-DJ2	JIS 20K Flange (Stainless Steel), 10 mm Diameter Nominal (*3)	Size 2.5 mm (0.1 in.) to 10 mm (0.4 in.)
	-PA1	ANSI Class 150 Flange (Stainless Steel) (*1)	Size 2.5 mm (0.1 in.) to 400 mm (16 in.) (*15) (*16) (*18)
	-PA2	ANSI Class 300 Flange (Stainless Steel) (*1)	Size 2.5 mm (0.1 in.) to 300 mm (12 in.) (*15) (*16) (*18)
	-PD1	DIN PN 10 Flange (Stainless Steel)	Size 200 mm (8.0 in.) to 400 mm (16 in.) (*15) (*16) (*18)
	-PD2	DIN PN 16 Flange (Stainless Steel) (*2)	Size 80 mm (3.0 in.) to 300 mm (12 in.) (*15) (*16) (*18)
	-PD4	DIN PN 40 Flange (Stainless Steel) (*1) (*2)	Size 2.5 mm (0.1 in.) to 50 mm (2.0 in.) (*15) (*16) (*18)
	-PJ1	JIS 10K Flange (Stainless Steel) (*1)	Size 2.5 mm (0.1 in.) to 400 mm (16 in.) (*15) (*16) (*18)
Lay Length	1	Standard	
Electrical Connection (*7)	-0	JIS G1/2 female	
	-2	ANSI 1/2 NPT female	Not available for Submersible Type
	-4	ISO M20×1.5 female	Not available for Submersible Type
Indicator (*5) (*8)	1	Integral Flowmeter with indicator (Horizontal)	
	2	Integral Flowmeter with indicator (Vertical)	
	N	Integral Flowmeter without indicator /Remote Flowtube	
Calibration	B	Standard	
	C	High Grade (*13)	Size 25 mm (1.0 in.) to 200 mm (8.0 in.), PFA lining only
Option	/□	Optional code (See the Table of Optional Specifications)	

T17.EPS

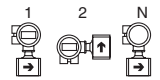
- *1: For a flange type of 2.5 to 10 mm (0.1 to 0.4 in.), prepare 15 mm (0.5 in.) diameter nominal flanges on the process pipe side.
(Process connection codes: BA1, BA2, BD4, BJ1, BJ2, PA1, PA2, PD4 and PJ1)
- *2: Even when DIN PN10 or 16 is required for a model of size 2.5 to 50 mm (0.1 to 2.0 in.), select PN40 (Process connection codes: BD4, CD4, DD4 and PD4) because there is no difference in the dimensions of the mating faces.
Even when DIN PN10 is required for a model of size 65 to 150 mm (2.5 to 6.0 in.), select PN16 (Process connection codes: BD2, CD2 and PD2) because there is no difference in the dimensions of the mating faces.
- *3: For a flange type of 2.5 to 10 mm (0.1 to 0.4 in.)(Process connection codes: DJ1, DJ2, and DD4), prepare 10 mm (0.4 in.) diameter nominal flanges on the process pipe side.
- *4: Mating dimensions are based on standards as follow:
ANSI:ASME B 16.5, DIN: DIN 2501, JIS:JIS B 2220 and JIS G 3443-2, JPI: JPI-7S-15-1999, AS: AS2129
- *5: N shall be always selected for remote flowtubes
In the case of an integral flowmeter, select from among the figures at the right:
- *6: For explosion proof types, specify types of explosion proof certification using the optional codes. For ATEX, IECEx or TIIS certified AXF remote flowtube, select "Combined Use with AXFA14" (Converter, output signal and communication code: -P). For the TIIS flameproof type with wiring using a flameproof packing adapter, select optional code G12 or G11. Available only for JIS G1/2 female electrical connections.
- *7: For explosion proof types, JIS G1/2 female electrical connection is available only for TIIS flameproof type.
- *8: In case of integral flowmeters of the TIIS flameproof type, select "with indicator"(Indicator code: 1 or 2).
- *9:  Users must consider the characteristics of selected wetted parts material and influence of process fluids.
The use of inappropriate materials can result in the leakage of corrosive process fluids and cause injury to personnel and/or damage to plant facilities. It is also possible that the instrument itself can be damaged and that fragments from the instrument can contaminate the user's process fluids.
Be very careful with highly corrosive process fluids such as hydrochloric acid, sulfuric acid, hydrogen sulfide, sodium hypochlorite, and high-temperature steam (150°C [302°F] or above).
Contact Yokogawa for detailed information of the wetted parts material.
- *10: For FOUNDATION fieldbus protocol, refer to IM 01E20F02-01E
- *11: For PROFIBUS PA protocol, refer to IM 01E20F12-01E.
- *12: Allowable fluid pressure should also be limited according to fluid temperature and pressure.
- *13: In the case of calibration code C in remote type, please order a combination of flowtube and converter.
- *14: For material specifications, refer to description of "Flowtube Material".
- *15: Available only for PFA lining and non-replaceable electrode.
- *16: Not available for 32 mm (1.25 in.), 65 mm (2.5 in.) and 125 mm (5.0 in.).
- *17: For 2.5 mm (0.1 in.) to 250 mm (10 in.), explosion proof type is available only for TIIS flameproof type.
For Size 300 mm (12 in.) to 400 mm (16 in.), explosion proof type is not available.
- *18: Explosion proof types are available for ATEX, FM, IECEx and CSA explosion proof type.
- *19: Explosion proof type is available only for IECEx explosion proof type.

AXF STANDARD (Clamp/Union/Butt Weld Connection)

Sanitary Type , PFA Lining

Model	Suffix Code	Description	Applicable Model
AXF015	Size 15 mm (0.5 in.), Integral Flowmeter/Remote Flowtube	
AXF025	Size 25 mm (1.0 in.), Integral Flowmeter/Remote Flowtube	
AXF032	Size 32 mm (1.25 in.), Integral Flowmeter/Remote Flowtube	
AXF040	Size 40 mm (1.5 in.), Integral Flowmeter/Remote Flowtube	
AXF050	Size 50 mm (2.0 in.), Integral Flowmeter/Remote Flowtube	
AXF065	Size 65 mm (2.5 in.), Integral Flowmeter/Remote Flowtube	
AXF080	Size 80 mm (3.0 in.), Integral Flowmeter/Remote Flowtube	
AXF100	Size 100 mm (4.0 in.), Integral Flowmeter/Remote Flowtube	
AXF125	Size 125 mm (5.0 in.), Integral Flowmeter/Remote Flowtube	
Use	H	Sanitary Type	
Converter, Output Signal and Communication	-D	Integral Flowmeter with 4 to 20 mA DC Output and BRAIN Communication	
	-E	Integral Flowmeter with 4 to 20 mA DC Output and HART Communication	
	-F	Integral Flowmeter with Digital communication (FOUNDATION fieldbus protocol) (*5)	
	-G	Integral Flowmeter with Digital communication (PROFIBUS PA protocol) (*6)	
	-N	Remote Flowtube for Combined use with AXFA11	
	-P	Remote Flowtube for Combined use with AXFA14	
Power Supply	1	Integral Flowmeter, 100 V to 240 V AC or 100 to 120 V DC	
	2	Integral Flowmeter, 24 V AC/DC	
	N	Remote Flowtube	
Lining (*4)	A	Fluorocarbon PFA	
Electrode Material (*4)	L	JIS SUS316L (AISI 316L SS/EN 1.4404 Equivalent)	
Electrode Structure	1	Non-replaceable	
Grounding Ring	N	None	
Process Connection (*2) (*4) (*7) (*9)	-HAB	Tri-Clamp (3A), JIS SUS316L or SUSF316L (AISI 316L SS/EN1.4404 Equivalent or ANSI F316L SS/EN1.4435 Equivalent)(*1)	Size 15 mm (0.5 in.) to 100 mm (4.0in.), except 32 mm (1.25 in.)
	-HDB	DIN32676 Clamp, JIS SUS316L or SUSF316L (AISI 316L SS/EN1.4404 Equivalent or ANSI F316L SS/EN1.4435 Equivalent)	Size 15 mm (0.5 in.) to 125 mm (5.0 in.)
	-HKB	ISO2852/SMS3016 Clamp, JIS SUS316L or SUSF316L (AISI 316L SS/EN1.4404 Equivalent or ANSI F316L SS/EN1.4435 Equivalent)	Size 15 mm (0.5 in.) to 125 mm (5.0 in.)
	-JDB	DIN11851 Union, SUS316L or SUSF316L (AISI 316L SS/EN1.4404 Equivalent or ANSI F316L SS/EN1.4435 Equivalent)	Size 15 mm (0.5 in.) to 125 mm (5.0 in.)
	-JKB	ISO2853 Union, SUS316L or SUSF316L (AISI 316L SS/EN1.4404 Equivalent or ANSI F316L SS/EN1.4435 Equivalent)	Size 15 mm (0.5 in.) to 100 mm (4.0 in.)
	-JSB	SMS1145 Union, SUS316L or SUSF316L (AISI 316L SS/EN1.4404 Equivalent or ANSI F316L SS/EN1.4435 Equivalent)	Size 25 mm (1.0 in.) to 100 mm (4.0 in.)
	-KDB	Butt Weld for DIN 11850 Pipe Connection (SUS316L or SUSF316L [AISI 316L SS/EN1.4404 Equivalent or ANSI F316L SS/EN1.4435 Equivalent])	Size 15 mm (0.5 in.) to 125 mm (5.0 in.)
	-KKB	Butt Weld for ISO 2037 Pipe Connection (SUS316L or SUSF316L [AISI 316L SS/EN1.4404 Equivalent or ANSI F316L SS/EN1.4435 Equivalent])	Size 15 mm (0.5 in.) to 125 mm (5.0 in.)
Lay Length	1	Standard	
Electrical Connection	-0	JIS G1/2 female	
	-2	ANSI 1/2 NPT female	
	-4	ISO M20×1.5 female	
Indicator (*3)	1	Integral Flowmeter with indicator (Horizontal)	
	2	Integral Flowmeter with indicator (Vertical)	
	N	Integral Flowmeter without indicator /Remote Flowtube	
Calibration	B	Standard	
	C	High Grade (*8)	Size 25 mm (1.0 in.) to 125 mm (5.0 in.)
Option	<input type="checkbox"/>	Optional code (See the Table of Optional Specifications)	

*1: For a tri-clamp type of size 15 mm (0.5 in.) (Process connection code: HAB), prepare a 3/4 in. tri-clamp on the process pipe side.

T18.EPS

*2: The detail dimensions of process connections (clamp/union/butt weld) are shown in the 'EXTERNAL DIMENSIONS' section of the sanitary type.
In case of Butt Weld type, ferrules, sleeves, or alternative must be provided by the user. User need to weld these parts to the butt weld adapter.

*3: N shall be always selected for remote flowtubes.

In the case of an integral flowmeter, select from among the following figures.

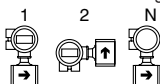

*4: ⚠ Users must consider the characteristics of selected wetted parts material and influence of process fluids.

The use of inappropriate materials can result in the leakage of corrosive process fluids and cause injury to personnel and/or damage to plant facilities. It is also possible that the instrument itself can be damaged and that fragments from the instrument can contaminate the user's process fluids.

Be very careful with highly corrosive process fluids such as hydrochloric acid, sulfuric acid, hydrogen sulfide, sodium hypochlorite, and high-temperature steam (150°C [302°F] or above). Contact Yokogawa for detailed information of the wetted parts material.

*5: For FOUNDATION fieldbus protocol, refer to IM 01E20F02-01E

*6: For PROFIBUS PA protocol, refer to IM 01E20F12-01E.

*7: Allowable fluid pressure should also be limited according to fluid temperature and pressure.

*8: In the case of calibration code C in remote type, please order a combination of flowtube and converter.

*9: For material specifications, refer to description of "Flowtube Material".

REPLACEMENT MODEL FOR EARLIER ADMAG OR ADMAG AE (Wafer Type)
General-purpose Use/Submersible Type/Explosion proof Type, PFA/Polyurethane Rubber Lining
 For the Wafer Types of size 250 mm (10 in.), 300 mm (12 in.), **AXF Standard** shall be selected.

Model	Suffix Code	Description	Applicable Model
AXF002	Size 2.5 mm (0.1 in.) Integral Flowmeter/Remote Flowtube (*8)	
AXF005	Size 5 mm (0.2 in.) Integral Flowmeter/Remote Flowtube (*8)	
AXF010	Size 10 mm (0.4 in.) Integral Flowmeter/Remote Flowtube (*8)	
AXF015	Size 15 mm (0.5 in.) Integral Flowmeter/Remote Flowtube (*8)	
AXF025	Size 25 mm (1.0 in.) Integral Flowmeter/Remote Flowtube	
AXF040	Size 40 mm (1.5 in.) Integral Flowmeter/Remote Flowtube	
AXF050	Size 50 mm (2.0 in.) Integral Flowmeter/Remote Flowtube	
AXF080	Size 80 mm (3.0 in.) Integral Flowmeter/Remote Flowtube	
AXF100	Size 100 mm (4.0 in.) Integral Flowmeter/Remote Flowtube	
AXF150	Size 150 mm (6.0 in.) Integral Flowmeter/Remote Flowtube	
AXF200	Size 200 mm (8.0 in.) Integral Flowmeter/Remote Flowtube	
Use	G	General-Purpose Use	Size 15 mm (0.5 in.) to 200 mm (8.0 in.), Remote Flowtube only PFA lining only
	W	Submersible Type	
	C	Explosion proof Type (*5)	
Converter, Output Signal and Communication	-D	Integral Flowmeter with 4 to 20 mA DC Output and BRAIN Communication	
	-E	Integral Flowmeter with 4 to 20 mA DC Output and HART Communication	
	-F	Integral Flowmeter with Digital communication (FOUNDATION fieldbus protocol) (*10)	
	-G	Integral Flowmeter with Digital communication (PROFIBUS PA protocol) (*11)	
	-N	Remote Flowtube for Combined Use with AXFA11	
	-P	Remote Flowtube for Combined Use with AXFA14 (*5)	
Power Supply	1	Integral Flowmeter, 100 V to 240 V AC or 100 to 120 V DC	
	2	Integral Flowmeter, 24 V AC/DC	
	N	Remote Flowtube	
Lining (*9)	A	Fluorocarbon PFA	Size 25 mm (1.0 in.) to 200 mm (8.0 in.)
	U	Polyurethane Rubber	
Electrode Material (*9)	L	JIS SUS316L (AISI 316L SS/EN 1.4404 Equivalent)	PFA lining only
	P	Platinum-iridium	
	H	Hastelloy C276 Equivalent	PFA lining only
	T	Tantalum	
	V	Titanium	Size 15 mm (0.5 in.) to 200 mm (8.0 in.)
	W	Tungsten Carbide	
Electrode Structure	1	Non-replaceable	
Grounding Ring and Grounding Electrode Material (*9)	N	None (*8)	Size 25 mm (1.0 in.) to 200 mm (8.0 in.) (*5)
	S	JIS SUS316 (AISI 316 SS/EN 1.4401 Equivalent)	
	L	JIS SUS316L or ASTM 316L (AISI 316L SS/EN 1.4404 Equivalent)	
	P	Platinum-iridium (*8)	
	H	Hastelloy C276 Equivalent	
	T	Tantalum (*8)	
	V	Titanium	
Process Connection (*3) (*12) (*13)	-AA1	ANSI Class 150 Wafer (*1)	Size 2.5 mm (0.1 in.) to 200 mm (8.0 in.)
	-AA2	ANSI Class 300 Wafer (*1)	Size 2.5 mm (0.1 in.) to 200 mm (8.0 in.)
	-AD1	DIN PN 10 Wafer	Size 200 mm(8.0 in.) only
	-AD2	DIN PN 16 Wafer (*2)	Size 80 mm (3.0 in.) to 200 mm (8.0 in.)
	-AD4	DIN PN 40 Wafer (*1) (*2)	Size 2.5 mm (0.1 in.) to 50 mm (2.0 in.)
	-AJ1	JIS 10K Wafer (*1)	Size 2.5 mm (0.1 in.) to 200 mm (8.0 in.)
	-AJ2	JIS 20K Wafer (*1)	Size 2.5 mm (0.1 in.) to 200 mm (8.0 in.)
	-AG1	JIS F12 (JIS75M) Wafer	Size 80 mm (3.0 in.) to 200 mm (8.0 in.)
Lay Length	2	Matches an Earlier ADMAG Flowmeter (ADMAG or ADMAG AE) for Replacement	
Electrical Connection (*6)	-0	JIS G1/2 female	Not available for Submersible Type Not available for Submersible Type
	-2	ANSI 1/2 NPT female	
	-4	ISO M20×1.5 female	
Indicator (*4) (*7)	1	Integral Flowmeter with indicator (Horizontal)	
	2	Integral Flowmeter with indicator (Vertical)	
	N	Integral Flowmeter without indicator /Remote Flowtube	
Calibration	B	Standard	
Option	<input type="checkbox"/>	Optional code (See the Table of Optional Specifications)	

T19.EPS

- *1: For a wafer type of 2.5 to 10 mm (0.1 to 0.4 in.), prepare 15 mm (0.5 in.) diameter nominal flanges on the process pipe side.
(Process connection codes: AA1, AA2, AD4, AJ1, and AJ2)
- *2: Even when DIN PN10 or 16 is required for a model of size 2.5 to 50 mm (0.1 to 2.0 in.), select PN40 (Process connection code: AD4) because there is no difference in the dimensions of the mating faces.
Even when DIN PN10 is required for a model of size 65 to 150 mm (2.5 to 6.0 in.), select PN16 (Process connection code: AD2) because there is no difference in the dimensions of the mating faces.
- *3: Mating dimensions are based on standards as follow:
ANSI: ASME B 16.5, DIN: DIN 2501, JIS: JIS B 2220 and JIS G 3443-2
- *4: N shall be always selected for remote flowtubes
In the case of an integral flowmeter, select from among the figures at the right:

1

2

N

- *5: For explosion proof types, specify types of explosion proof certification using the optional codes. For ATEX, IECEx or TIIS certified AXF remote flowtube, select "Combined Use with AXFA14" (Converter, output signal and communication code: -P). For the TIIS flameproof type with wiring using a flameproof packing adapter, select optional code G12 or G11. Available only for JIS G1/2 female electrical connections.
- *6: For explosion proof types, JIS G1/2 female electrical connection is available only for TIIS flameproof type.
- *7: In case of integral flowmeters of the TIIS flameproof type, select "with indicator" (Indicator code: 1 or 2).
- *8: In case of platinum-iridium (Grounding ring code: P) or tantalum (Grounding ring code: T) or None (Grounding ring code: N) in wafer type of 2.5 mm (0.1 in.) to 15 mm (0.5 in.), the lay lengths of Replacement model are the same as those for AXF Standard.
In this case, AXF Standard shall be selected.
- *9: ΔUsers must consider the characteristics of selected wetted parts material and influence of process fluids.
The use of inappropriate materials can result in the leakage of corrosive process fluids and cause injury to personnel and/or damage to plant facilities. It is also possible that the instrument itself can be damaged and that fragments from the instrument can contaminate the user's process fluids.
Be very careful with highly corrosive process fluids such as hydrochloric acid, sulfuric acid, hydrogen sulfide, sodium hypochlorite, and high-temperature steam (150°C [302°F] or above). Contact Yokogawa for detailed information of the wetted parts material.
- *10: For FOUNDATION fieldbus protocol, refer to IM 01E20F02-01E
- *11: For PROFIBUS PA protocol, refer to IM 01E20F12-01E.
- *12: Allowable fluid pressure should also be limited according to fluid temperature and pressure.
- *13: For material specifications, refer to description of "Flowtube Material".

REPLACEMENT MODEL FOR EARLIER ADMAG OR ADMAG AE (Flange Type)**General-purpose Use/Submersible Type/Explosion proof Type, PFA/Polyurethane Rubber Lining**

For Flange Types of size 15 mm (0.5 in.) to 100 mm (4.0 in.), 300 mm (12 in.) to 400 mm (16 in.), **AXF Standard** shall be selected.

Model	Suffix Code	Description	Applicable Model
AXF150	Size 150 mm (6.0 in.) Integral Flowmeter/Remote Flowtube	
AXF200	Size 200 mm (8.0 in.) Integral Flowmeter/Remote Flowtube	
AXF250	Size 250 mm (10 in.) Integral Flowmeter/Remote Flowtube	
Use	G	General-Purpose Use	Remote Flowtube only PFA lining only
	W	Submersible Type	
	C	Explosion proof Type (*4)	
Converter, Output Signal and Communication	-D	Integral Flowmeter with 4 to 20 mA DC Output and BRAIN Communication	
	-E	Integral Flowmeter with 4 to 20 mA DC Output and HART Communication	
	-F	Integral Flowmeter with Digital communication (FOUNDATION fieldbus protocol) (*8)	
	-G	Integral Flowmeter with Digital communication (PROFIBUS PA protocol) (*9)	
	-N	Remote Flowtube for Combined Use with AXFA11	
	-P	Remote Flowtube for Combined Use with AXFA14 (*4)	
Power Supply	1	Integral Flowmeter, 100 V to 240 V AC or 100 to 120 V DC	
	2	Integral Flowmeter, 24 V AC/DC	
	N	Remote Flowtube	
Lining (*7)	A	Fluorocarbon PFA	
	U	Polyurethane Rubber	
Electrode Material (*7)	L	JIS SUS316L (AISI 316L SS/EN 1.4404 Equivalent)	PFA lining only PFA lining only
	P	Platinum-iridium	
	H	Hastelloy C276 Equivalent	
	T	Tantalum	
	V	Titanium	
	W	Tungsten Carbide	
Electrode Structure	1	Non-replaceable	General-Purpose use, Electrode Material : JIS SUS316L only
	2	Replaceable	
Grounding Ring and Grounding Electrode Material (*7)	N	None	Size150 mm (6.0 in.), 200 mm (8.0 in.), PFA lining only Size150 mm (6.0 in.), 200 mm (8.0 in.), PFA lining only
	S	JIS SUS316 (AISI 316 SS/EN 1.4401 Equivalent)	
	L	JIS SUS316L or ASTM 316L (AISI 316L SS/EN 1.4404 Equivalent)	
	P	Platinum-iridium	
	H	Hastelloy C276 Equivalent	
	T	Tantalum	
Process Connection (*2) (*10) (*11)	-CA1	ANSI Class 150 Flange (Carbon Steel)	Size 150 mm (6.0 in.) to 250 mm (10 in.) (*12) Size 150 mm (6.0 in.) to 250 mm (10 in.) (*12) Size 200 mm (8.0 in.) to 250 mm (10 in.) (*12) Size 150 mm (6.0 in.) to 250 mm (10 in.) (*12) Size 150 mm (6.0 in.) to 250 mm (10 in.) (*12) Size 150 mm (6.0 in.) to 250 mm (10 in.) (*12) Size 150 mm (6.0 in.) to 250 mm (10 in.) (*12)
	-CA2	ANSI Class 300 Flange (Carbon Steel)	
	-CD1	DIN PN 10 Flange (Carbon Steel)	
	-CD2	DIN PN 16 Flange (Carbon Steel) (*1)	
	-CJ1	JIS 10K Flange (Carbon Steel)	
	-CJ2	JIS 20K Flange (Carbon Steel)	
	-CG1	JIS F12 (JIS75M) Flange (Carbon Steel)	
Lay Length	2	Matches an Earlier ADMAG Flowmeter (ADMAG or ADMAG AE) for Replacement	
Electrical Connection (*5)	-0	JIS G1/2 female	Not available for Submersible Type Not available for Submersible Type
	-2	ANSI 1/2 NPT female	
	-4	ISO M20×1.5 female	
Indicator (*3) (*6)	1	Integral Flowmeter with indicator (Horizontal)	
	2	Integral Flowmeter with indicator (Vertical)	
	N	Integral Flowmeter without indicator /Remote Flowtube	
Calibration	B	Standard	
Option	<input type="checkbox"/>	Optional code (See the Table of Optional Specifications)	

T20.EPS

- *1: Even when DIN PN10 is required for a 150 (6.0 in.)-mm model, select PN16 (Process connection code: CD2) because there is no difference in the dimensions of the mating faces.
- *2: Mating dimensions are based on standards as follow:
ANSI: ASME B 16.5, DIN: DIN 2501, JIS: JIS B 2220 and JIS G 3443-2
- *3: N shall be always selected for remote flowtubes.
In the case of an integral, select from among the following figures:

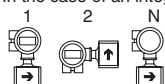

- *4: For explosion proof types, specify types of explosion proof certification using the optional codes. For ATEX, IECEx or TIIS certified AXF remote flowtube, select "Combined Use with AXFA14" (Converter, output signal and communication code: -P). For the TIIS flameproof type with wiring using a flameproof packing adapter, select optional code G12 or G11. Available only for JIS G1/2 female electrical connections.
- *5: For explosion proof types, JIS G1/2 female electrical connection is available only for TIIS flameproof type.
- *6: In case of integral flowmeters of the TIIS flameproof type, select "with indicator" (Indicator code: 1 or 2).
- *7: Δ Users must consider the characteristics of selected wetted parts material and influence of process fluids.
The use of inappropriate materials can result in the leakage of corrosive process fluids and cause injury to personnel and/or damage to plant facilities. It is also possible that the instrument itself can be damaged and that fragments from the instrument can contaminate the user's process fluids.
Be very careful with highly corrosive process fluids such as hydrochloric acid, sulfuric acid, hydrogen sulfide, sodium hypochlorite, and high-temperature steam (150°C [302°F] or above). Contact Yokogawa for detailed information of the wetted parts material.
- *8: For FOUNDATION fieldbus protocol, refer to IM 01E20F02-01E
- *9: For PROFIBUS PA protocol, refer to IM 01E20F12-01E.
- *10: Allowable fluid pressure should also be limited according to fluid temperature and pressure.
- *11: For material specifications, refer to description of "Flowtube Material".
- *12: Explosion proof types are available for ATEX, FM, IECEx and CSA explosion proof type.

■ OPTIONAL SPECIFICATIONS FOR FLOWTUBES

● Table of Optional Specifications “◇”

○: Available -: Not available

Item	Specifications	Applicable Model							Code
		General		Explosion proof		Submersible	Sanitary		
		Integral Flowmeter	Remote Flowtube	Integral Flowmeter	Remote Flowtube	Remote Flowtube	Integral Flowmeter	Remote Flowtube	
		◇ W L L ◇ AXF**G	◇ N P AXF**G-P	◇ W L L ◇ AXF**C	◇ N P AXF**C	◇ N P AXF**W-P	◇ W L L ◇ AXF**H	◇ N P AXF**H	
For District Heating and Cooling or Condensation-proof	Urethane resin potting is applied in the terminal box of a remote flowtube. Select JIS G1/2 for the electrical connections. 30-meter signal and excitation cables are pre-wired and waterproof grounds with union joints are attached at factory.	-	○	-	-	-	-	○	DHC
User-specified Signal and Excitation Cable Length	Available for the submersible type and a model with optional code DHC. The cable length is limited up to 200 meters when combined with an AXFA11 converter, or 100 meters when combined with an AXFA14 converter. Following “L,” specify the cable length in three digits as a multiple of 1 meter (e.g., 001, 002, or 005) for a length up to 5 meters, or as a multiple of 5 meters (i.e., 005, 010, 015, or the like) for a length of 5 meters or more. If this optional code is not selected, a 30-meter length cable is attached.	-	○	-	-	○	-	○	L**
Lightning Protector	A lightning protector is built into the power terminals.	○	-	○	-	-	○	-	A
DC Noise Cut Circuit	The DC Noise Cut Circuit is built in. Available for 15 mm (0.5 in.) and larger sizes, and for fluids with the conductivity of 50 μS/cm or higher. Nullifies the empty check and electrode adhesion diagnostic function.	○	-	○	-	-	○	-	ELC
Burn Out Down (*9)	The output level is set to 0 mA during a CPU failure and is set 2.4 mA (-10%) or less during an alarm. Standard products are delivered with a setting 25 mA during a CPU failure and 21.6 mA (110%) or more during an alarm.	○	-	○	-	-	○	-	C1
NAMUR NE43 Compliance (*9)	Output signal	○	-	○	-	-	○	-	C2
	Failure alarm down-scale: The output level is set to 0 mA during a CPU failure and is set 2.4 mA (-10%) or less during an alarm. Failure alarm up-scale: The output level is set to 25 mA during a CPU failure and is set 21.6 mA (110%) or more during an alarm.	○	-	○	-	-	○	-	C3
Active Pulse Output (*9)	Active pulses are output in order to drive an external electromagnetic or electronic counter directly using the converter's internal power supply. (Nullifies the standard transistor contact pulse output.) Output voltage: 24 V DC ±20% Pulse specifications: • The drive current of 150 mA or less • Pulse rate: 0.0001 to 2 pps (pulse/second); Pulse width: 20, 33, 50, or 100 ms	○	-	○	-	-	○	-	EM
Mass Unit Setting	The flow rate span, transmission pulse weight, and totalizer display pulse weight can be set in terms of mass unit. Specify the density of the process fluid when ordering in addition to the mass flow rate span, transmission pulse weight (for mass unit), and totalizer display pulse weight (for mass unit). When ordering a remote flowtube, parameters for 'Mass Unit Setting' will be set in the corresponding converter before shipment. 1. Density a. Available density Numerics: Specify the numeric within the value of 500 to 2000 kg/m ³ , 4.2 to 16.7 lb/gal, or 31.2 to 124.8 lb/cf. And it can be up to five digits, to a maximum of 32000 ignoring the decimal point. A fraction is limited to the fourth decimal place. b. Available density units: kg/m ³ , lb/gal, lb/cf Example: A water density is about 1000kg/m ³ . In this case specify “1000kg/m ³ ”. However a density is changed by temperature. Specify the actual density. (The 1000kg/m ³ is equivalent to 8.345lb/gal and 62.43lb/cf.) 2. The mass flow rate span, transmission pulse weight, and totalizer display pulse weight a. Available density Numerics: Specify the numeric within the value of 0.0001 to 32000. And it can be up to five digits, to a maximum of 32000 ignoring the decimal point. A fraction is limited to the fourth decimal place. b. Mass Units Available mass units: t, kg, g, klb, lb Available time units: /d, /h, /min, /s Note1: In case of specifying the mass flow span, calculate the volumetric flow span by the setting density, and specify the available value in the mass flow span. Note2: In case of transmission pulse weight and totalizer display pulse weight, specify the mass unit which was specified as the flow unit.	○	○	○	○	○	○	○	MU

T26-1.EPS

● Table of Optional Specifications (continued)

○: Available --: Not available

Item	Specifications	Applicable Model							Code	
		General		Explosion proof		Submersible	Sanitary			
		Integral Flowmeter	Remote Flowtube	Integral Flowmeter	Remote Flowtube	Remote Flowtube	Integral Flowmeter	Remote Flowtube		
		ΔωΔΔΔ	Z	ΔωΔΔΔ	Z P	Z P	ΔωΔΔΔ	Z P		
		AXF***G	AXF***G-P	AXF***C	AXF***C-P	AXF***W/P	AXF***H	AXF***H-P		
G3/4 Female Waterproof Glands	Waterproof glands for G3/4 conduits or flexible tubes are attached to the electrical connections. Available only for JIS G1/2 female electric connections.	-	○	-	-	-	-	○	EW	
Waterproof Glands	Waterproof glands are attached to the electrical connections. Available only for JIS G1/2 female electric connections.	○	○	-	-	-	○	○	EG	
Waterproof Glands with Union Joints	Waterproof glands with union joints are attached to the electrical connections. Available only for JIS G1/2 female electric connections.	○	○	-	-	-	○	○	EU	
Plastic Glands	Plastic glands are attached to the electrical connections. Available only for JIS G1/2 female electric connections.	○	○	-	-	-	○	○	EP	
Mirror Finished PFA Lining	Mirror finishing on the PFA lining inside of the tube to the smoothness lining. Available for 15 mm (0.5 in.) and larger sizes. The Ra is average of measured values on several point. Size 15 to 200 mm (0.5 to 8.0 in.) : Ra 0.05 to 0.15 μm Size 250 to 400 mm (10 to 16 in.) : Ra 0.05 to 0.25 μm	○	○	○	○	○	○	○	PM	
Mirror Finished Ceramics	Mirror finishing on the inside of the ceramics tube to Ra ≤ 0.1 μm. Available for 5 mm (0.2 in.) and larger sizes. The Ra is average of measured values on several point.	○	○	○	○	-	-	-	CM	
Stainless Steel Tag Plate	A pendant tag plate of JIS SUS304 (AISI 304 SS/EN 1.4301 equivalent) is provided. Choose this option when a pendant tag plate is required in addition to the standard name plate with the tag number inscribed on it. Dimension (Height × Width): Appr. 12.5 (4.92) × 40 (15.7) mm (inch)	○	○	○	○	○	○	○	SCT	
Direction change of the electrical connection (*1)	+90 degrees rotated converter (or terminal box) to change the direction of the electrical connection.	○	○	○	○	○	○	○	RA	
	+180 degrees rotated converter (or terminal box) to change the direction of the electrical connection.	○	○	○	○	○	○	○	RB	
	-90 degrees rotated converter (or terminal box) to change the direction of the electrical connection.	○	○	○	○	○	○	○	RC	
Bolts, Nuts, and Gaskets (*2)	Bolts, nuts, and gaskets are provided for wafer connections. Available only for ANSI Class 150, JIS 10K, JIS 20K or JPI Class 150 wafer connections.	Bolts and nuts: Carbon steel; Gaskets: Chloroprene rubber (*3)	○	○	○	○	○	-	-	BCC
		Bolts and nuts: Carbon steel; Gaskets: PTFE-sheathed non-asbestos (*4)	○	○	○	○	○	-	-	BCF
		Bolts: JIS SUS304 (AISI 304 SS stainless steel equivalent); Nuts: JIS SUS403 (AISI 403SS stainless steel equivalent) ; Gaskets: Chloroprene rubber (*3)	○	○	○	○	○	-	-	BSC
		Bolts: JIS SUS304 (AISI 304 SS stainless steel equivalent); Nuts: JIS SUS403 (AISI 403SS stainless steel equivalent) ; Gaskets: PTFE-sheathed non-asbestos (*4)	○	○	○	○	○	-	-	BSF
Special Gaskets (*5) (*10)	Viton® gaskets for use with a PFA or ceramics lining with PVC piping. Allowable temperature and pressure are equivalent to Valqua #4010, special fluororubber not mixed. Available for 2.5 mm (0.1 in.) to 200 mm (8.0 in.) of PFA lining or 15 to 200 mm (0.5 to 8 in.) sizes of ceramics lining.	○	○	○	○	○	-	-	GA	
	Acid-resistant Viton® gaskets for use with a PFA or ceramics lining with PVC piping. Allowable temperature and pressure are equivalent to Valqua #4010, special fluororubber mixed (mixing #D2470). Available for 2.5 mm (0.1 in.) to 200 mm (8.0 in.) of PFA lining or 15 to 200 mm (0.5 to 8 in.) sizes of ceramics lining.	○	○	○	○	○	-	-	GC	
	Alkali-resistant Viton® gaskets for use with a PFA or ceramics lining with PVC piping. Allowable temperature and pressure are equivalent to Valqua #4010, special fluororubber mixed (mixing #RCD970). Available for 2.5 mm (0.1 in.) to 200 mm (8.0 in.) of PFA lining or 15 to 200 mm (0.5 to 8 in.) sizes of ceramics lining.	○	○	○	○	○	-	-	GD	
	Alkali-resistant carbonized fluororesin gaskets for use with a ceramics lining with metal piping. Allowable temperature and pressure are equivalent to Valqua #7026.	○	○	○	○	-	-	-	GF	
	Silicon rubber gaskets for Sanitary Type, provided between the lining and the adapter. For the condition of fluid temp. 120 to 160°C (248 to 320°F).	-	-	-	-	-	○	○	GH	

T26-2.EPS

● Table of Optional Specifications (continued)

○: Available -: Not available

Item	Specifications	Applicable Model							Code
		General		Explosion proof		Submersible	Sanitary		
		Integral Flowmeter	Remote Flowtube	Integral Flowmeter	Remote Flowtube	Remote Flowtube	Integral Flowmeter	Remote Flowtube	
		□ ▽ ▢ ▣ ▤	○ □ ▢ ▣ ▤	□ ▽ ▢ ▣ ▤	○ □ ▢ ▣ ▤	○ □ ▢ ▣ ▤	□ ▽ ▢ ▣ ▤	○ □ ▢ ▣ ▤	
Oil-prohibited Use	Electrodes, linings, grounding rings/grounding electrodes, gaskets and adapters (for sanitary type) are assembled and packed with polyethylene after being cleaned with water and acetone and dried with air. The label 'OIL FREE' is affixed.	○	○	○	○	-	○	○	K1
Oil-prohibited Use with Dehydrating Treatment	Electrodes, linings, and grounding rings are assembled and packed with polyethylene including desiccants after being cleaned with water and acetone and dried with air. The label 'OIL & WATER FREE' is affixed.	○	○	○	○	-	-	-	K5
Painting Color Change	Coated in black (Munsell N1.5 or its equivalent.)	○	○	○	○	-	○	○	P1
	Coated in jade green (Munsell 7.5 BG 4/1.5 or its equivalent.)	○	○	○	○	-	○	○	P2
	Coated in metallic silver.	○	○	○	○	-	○	○	P7
Epoxy Resin Coating	Epoxy resin coating which has alkali-resistance instead of standard polyurethane resin coating. The color is same as standard type.	○	○	○	○	-	-	-	X1
High Anti-corrosion Coating	Three-layer coating (polyurethane coating on two-layer epoxy resin coating) in the same range as that for the standard coating. The color is same as standard type. Salt/alkali/acid/weather-resistance.	○	○	○	○	-	-	-	X2
Calibration Certificate	Level 2: The Declaration and the Calibration Equipment List are issued.	○	○	○	○	○	○	○	L2
	Level 3: The Declaration and the Primary Standard List are issued.	○	○	○	○	○	○	○	L3
	Level 4: The Declaration and the Yokogawa Measuring Instruments Control System are issued.	○	○	○	○	○	○	○	L4
Material Certificate	Reproduced material certificate for pipe, electrodes, grounding rings or grounding electrodes, flanges or mini flanges, adapters (for sanitary type). For ceramics lining models, only grounding rings or grounding electrodes or union joint	○	○	○	○	○	○	○	M01
	M01: Material Certificate E01: Material Certificate with cover according to EN10204 3.1	○	○	○	○	○	○	○	E01
Hydrostatic Test	The test verifies the absence of leaks by applying the following water pressures (which are determined under process connection conditions) to linings for ten minutes. Test results are described in a test certificate (QIC). Process Connection: ANSI Class 150, DIN PN10, JIS 10K, JPI Class 150, AS Table D Water Pressure: 1.5 MPa ANSI Class 300, DIN PN16, JIS 20K, AS Table E 3.0 MPa DIN PN40, Union joint (Ceramics lining) 6.0 MPa JIS F12 1.25 MPa	○	○	○	○	○	-	-	T01
Withstand Voltage Test Certificate (*11) (*12)	The test verifies the withstand voltage by applying the following conditions for remote flowtube of General-purpose use or Submersible type. (For remote flowtube of Explosion proof type, this test is performed as standard.) Test results are described in a test certificate (QIC). WT1: Between excitation current terminal and ground terminal, 1000V AC for 1 minute	-	○	-	-	○	-	-	WT1
	WT2: Between excitation current terminal and ground terminal, and between signal terminals and excitation current terminal, 1500V AC for 1 minute	-	○	-	-	○	-	-	WT2
PMI Test Certificate (*13) (*14) (*15)	Positive Material Identification test certificate of three major chemical components (Nickel, Chromium and Molybdenum) for specified materials.	○	○	○	○	○	-	-	PM1
	PM1: grounding rings	○	○	○	○	○	-	-	PM2
	PM2: grounding rings, and flanges or mini flanges PM3: grounding rings, flanges or mini flanges, and pipe	○	○	○	○	○	-	-	PM3
Liquid Penetration Test Certificate (*16)	Liquid penetration test certificate for the welded part of flanges or mini flanges.	○	○	○	○	○	○	○	PT
Welding Document (*16)	Welding document for the welded portion of flanges or mini flanges. WPA: According to ASME standards · Welding Procedure Specification (WPS) · Procedure Qualification Record (PQR) · Welder Performance Qualification (WPQ) or Welding Operator Performance Qualification (WOPQ)	○	○	○	○	○	○	○	WPA
Vent Hole	With a vent hole provided for permeable fluids (such as nitric acid, hydrofluoric acid, or sodium hydroxide at high temperature). Available only for a PFA lining flange type.	○	○	○	○	-	-	-	H

T26-3.EPS









● Table of Optional Specifications (continued)

○: Available -: Not available

Item	Specifications	Applicable Model							Code
		General		Explosion proof		Submersible	Sanitary		
		Integral Flowmeter	Remote Flowtube	Integral Flowmeter	Remote Flowtube	Remote Flowtube	Integral Flowmeter	Remote Flowtube	
		□ W L L □ A X F ** C	□ Z P A X F ** C	□ W L L □ A X F ** C	□ Z P A X F ** C	□ Z P A X F ** W P	□ W L L □ A X F ** H	□ Z P A X F ** H	
Enhanced Dual Frequency Excitation (*6)	Available for 25 to 200 mm (1.0 to 8.0 in.) sizes. Products are delivered with the Standard dual frequency excitation mode and the Enhanced dual frequency excitation mode enabled. Although the meter factors for the Standard dual frequency excitation mode and the Enhanced dual frequency excitation mode are inscribed on the name plate, the flow calibration of optional code HF1 is not performed in Enhanced dual frequency excitation. Excitation mode select optional code HF2 when an accurate flow measurement is required.	○	○	○	○	○	○	○	HF1
	Available for 25 to 200 mm (1.0 to 8.0 in.) sizes. Products are delivered with the Standard dual frequency excitation mode and the Enhanced dual frequency excitation mode enabled. The meter factor for the Enhanced dual frequency excitation obtained by flow calibration is inscribed on the name plate and set into the combined converter in addition to the meter factor for the Standard dual frequency excitation.	○	○	○	○	○	○	○	HF2
Five-point Calibration in User-specified Span	A flow test near 0, 25, 50, 75, and 100% of the user-specified span is performed instead of the flow test of the standard 2m/s span and a test certificate (QIC) is submitted. Specify the span (100% flow span) whose corresponding flow velocity lies between 0.5 to 10 m/s (0.8 to 10 m/s for sizes 32, 65, and 125 mm) and that is less than the maximum line capacity. Selectable range of flow rate span is showing below. Size : mm Selectable range of flow rate span : m³/h (in.) (Flow rate span velocity : m/s) 2.5 (0.1) 0.009 (0.5) to 0.05 (2.83) 5 (0.2) 0.036 (0.5) to 0.2 (2.83) 10 (0.4) 0.15 (0.5) to 0.96 (3.40) 15 (0.5) 0.32 (0.5) to 2.8 (4.40) 25 (1) 0.89 (0.5) to 11 (6.22) 32 (1.25) 2.32 (0.8) to 28.9 (10.00) 40 (1.5) 2.27 (0.5) to 28.0 (6.30) 50 (2) 3.54 (0.5) to 56 (7.92) 65 (2.5) 9.56 (0.8) to 80 (6.70) 80 (3) 9.05 (0.5) to 126 (6.96) 100 (4) 14.2 (0.5) to 190 (6.72) 125 (5) 35.3 (0.8) to 300 (6.79) 150 (6) 31.9 (0.5) to 380 (5.97) 200 (8) 56.6 (0.5) to 670 (5.92) 250 (10) 88.4 (0.5) to 1000 (5.66) 300 (12) 128 (0.5) to 1200 (4.72) 350 (14) 174 (0.5) to 1200 (3.47) 400 (16) 227 (0.5) to 1350 (2.98)	○	○	○	○	○	○	○	SC
ATEX Certification	ATEX Explosion proof See "HAZARDOUS AREA CLASSIFICATION"	-	-	○	○ (*8)	-	-	-	KF21
FM Approval	FM Explosion proof See "HAZARDOUS AREA CLASSIFICATION"	-	-	○	○	-	-	-	FF1
CSA Certification	CSA Explosion proof, Dual Seal See "HAZARDOUS AREA CLASSIFICATION"	-	-	○	○	-	-	-	CF1
IECEX Certification	IECEX Explosion proof See "HAZARDOUS AREA CLASSIFICATION"	-	-	○	○ (*8)	-	-	-	SF21
TIIS Certification	TIIS Flameproof See "HAZARDOUS AREA CLASSIFICATION"	-	-	○	○ (*8)	-	-	-	JF3
Flameproof packing adapter for TIIS Flameproof Type (*7)	Two flameproof packing adapters	-	-	○	○	-	-	-	G12
	One flameproof packing adapter and a blanking plug. Applicable for integral flowmeter and only when a four-wire cable is used for power input and signal output.	-	-	○ (*9)	-	-	-	-	G11

T26-4.EPS

● Table of Optional Specifications (continued)

*1:	Standard	+90-degree rotation	+180-degree rotation	-90-degree rotation
		Optional Code RA	Optional Code RB	Optional Code RC
Integral Flowmeter	Electrical Connection 	Indicator 	Electrical Connection 	Indicator 
Remote Flowtube		Electrical Connection 		Electrical Connection 

*2: When specifying the optional code BCC or BSC for a PFA or ceramics lining, it is advisable to specify the optional code GA, GC, or GD at the same time to prevent potential leakage caused by the difference in elasticity between the flowtube and chloroprene gaskets. Refer to description of "Gasket" in the "Wetted Part Material".

*3: Allowable temperature and pressure with the optional code BCC or BSC (only for Gaskets: Chloroprene rubber) are equivalent to Valqua #2010.

*4: Allowable temperature and pressure with the optional code BCF or BSF (only for Gaskets: PTFE-sheathed non-asbestos) are equivalent to Valqua #7030 (S).

*5: Special gaskets are inserted between the flowtube and the grounding ring or grounding electrode.

*6: Enhanced dual frequency excitation is not available for models with calibration code C (High Grade Accuracy).

*7: Select optional code G12 or G11 when TIIS Flameproof type with wiring using a flameproof packing adapter. Available only for JIS G1/2 female electric connection.

*8: For ATEX, IECEx or TIIS certified AXF remote flowtube, select "Combined Use with AXFA14" (Converter, output signal and communication code: -P).

*9: In the case of fieldbus communication type, optional codes C1, C2, C3, EM and G11 are not available.

*10: In the case of size 32 mm, optional code GH is not available.

*11: Neither optional code WT1 nor WT2 is available for models with lining material "Natural Soft Rubber" or "EPDM Rubber" (Lining code: D or G).

*12: Either optional code WT1 or WT2 can be selected.

*13: In case of sanitary type or union joint type with ceramics lining, optional code PM1, PM2 or PM3 is not available as they have no grounding rings.

*14: In case of carbon steel flanges or mini flanges, the amount of Nickel, Chromium and Molybdenum in the carbon steel are not stipulated and optional code PM2 or PM3 is not available. For material specifications, refer to description of "Flowtube Material".

*15: Only one code from optional code PM1, PM2 or PM3 can be selected.

*16: In case of no welded portion, optional code PT and WPA are not available. For available sizes, refer to the following table.

Optional code	Lining code	Process connection code	Size
PT	A, U, D, G	A**	25 to 300 mm (1.0 to 12 in.) Note: Not available for size 25 mm (1.0 in.) with lay length code: 1)
	A, U, D, G	B**	25 to 400 mm (1.0 to 16 in.)
	A, U, D, G	C**	50 to 400 mm (2.0 to 16 in.)
	A	P**	25 to 400 mm (1.0 to 16 in.)
	A	H**, J**, K**	32 to 125 mm (1.25 to 5.0 in.)
WPA	A, U, D, G	A**	25 to 300 mm (1.0 to 12 in.) Note: Not available for size 25 mm (1.0 in.) with lay length code: 1)
	A, U, D, G	B**	2.5 to 400 mm (0.1 to 16 in.)
	A, U, D, G	C**	50 to 400 mm (2.0 to 16 in.)
	A	P**	2.5 to 400 mm (0.1 to 16 in.)
	A	H**, J**, K**	32 to 125 mm (1.25 to 5.0 in.)

T26-4_1.EPS

EXTERNAL DIMENSIONS

AXF Standard, AXF002-AXF015, Wafer Type, PFA Lining

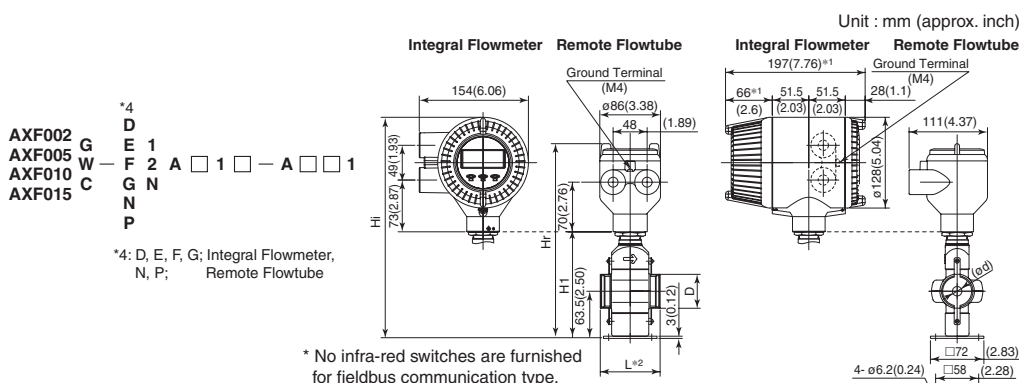

Model	Size code	002	005	010	015
	Size	2.5(0.1)	5(0.2)	10(0.4)	15(0.5)
	Lining code	A	A	A	A
Remote flowtube	Face-to-face length	L*2	81(3.19)		
	Outside dia.	D	44(1.73)		
Integral flowmeter	Inner diameter of Grounding ring	ød	15(0.59)		
	Height	H1	144(5.67)		
Remote flowtube	Max. Height	Hr	268(10.55)		
	Weight kg (lb)*3		2.4(5.3)		
Integral flowmeter	Max. Height	Hi	306(12.03)		
	Weight kg (lb)		4.1(9.0)		

- *1: When indicator code N is selected, subtract 12 mm (0.47 inch) from the value in the figure. In case of explosion proof type with indicator, add 5 mm (0.2 inch) to it.
- *2: Depending on the selection of grounding ring code and optional code, add the following value to L (face-to-face length).

Option Code	Grounding Ring Code	S, L, H, V	P, T	N
	None	+0	+26(1.02)	-2(0.08)
	GA, GC, GD (Special Gaskets)	+6(0.24)	+28(1.10)	-

- *3: When submersible type or option code DHC is selected, waterproof glands and a 30m long cable are attached. Add 9.5kg(20.9lb) to the weight in the table.

F22.EPS

AXF Standard, AXF025-AXF125, Wafer Type, PFA /Polyurethane Rubber /Natural Soft Rubber /EPDM Rubber Lining

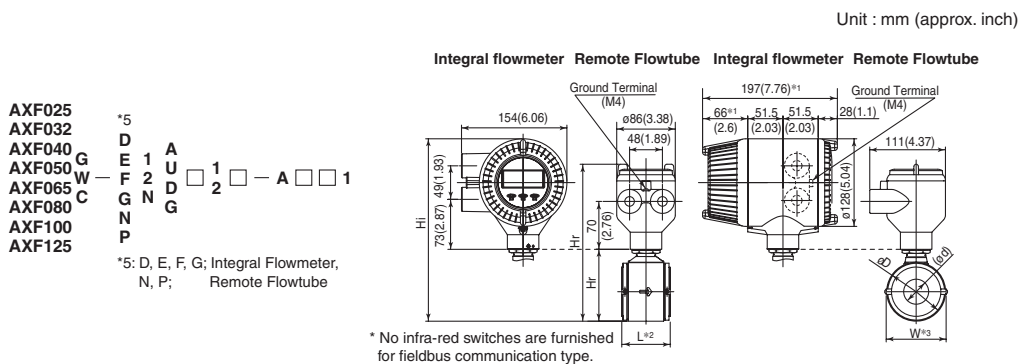

Model	Size code	025	032	040	050	065	080	100	125	
	Size	25(1)	32(1.25)	40(1.5)	50(2)	65(2.5)	80(3)	100(4)	125(5)	
	Lining code	A,U	A,U	A,U	A,U D,G	A,U D,G	A,U D,G	A,U D,G	A,U D,G	
Remote Flowtube	Face-to-face length	L*2	60(2.36) 70(2.76) 70(2.76) 80(3.15) 100(3.94) 120(4.72) 150(5.91) 200(7.87)							
	Outside dia.	øD	67.5(2.66) 73(2.87) 86(3.39) 99(3.90) 117(4.61) 129(5.08) 155(6.10) 183(7.20)							
Integral Flowmeter	Inner diameter of Grounding ring	ød	28(1.10) 34(1.34) 41(1.61) 53(2.09) 66(2.60) 77(3.03) 102(4.02) 128(5.04)							
	Width	W*3	67.5(2.66) 73(2.87) 86(3.39) 99(3.90) 117(4.61) 129(5.08) 155(6.10) 183(7.20)							
Remote Flowtube	Height	H1	92(3.62) 98(3.86) 111(4.37) 129(5.08) 147(5.79) 157(6.18) 183(7.20) 212(8.35)							
	Max. Height	Hr	216(8.50) 222(8.74) 235(9.25) 253(9.96) 271(10.67) 281(11.06) 307(12.09) 336(13.23)							
Integral Flowmeter	Weight kg (lb)*4		1.9(4.1) 2.0(4.5) 2.2(4.9) 2.7(5.8) 3.4(7.6) 4.1(9.1) 5.6(12.3) 9.3(20.4)							
	Max. Height	Hi	254(9.98) 260(10.24) 273(10.73) 291(11.44) 309(12.17) 319(12.54) 345(13.56) 374(14.70)							
	Weight kg (lb)		3.6(7.8) 3.7(8.2) 3.9(8.7) 4.4(9.6) 5.1(11.3) 5.8(12.9) 7.3(16.0) 11.0(24.2)							

- *1: When indicator code N is selected, subtract 12 mm (0.47 inch) from the value in the figure. In case of explosion proof type with indicator, add 5 mm (0.2 inch) to it.
- *2: Depending on the selection of grounding ring code and optional code, add the following value to L (face-to-face length).

Option Code	Grounding Ring Code	S, L, H, V	P, T	N
	None	+0	+26(1.02)	-2(0.08)
	GA, GC, GD (Special Gaskets)	+8(0.31)	+30(1.18)	-

- *3: When electrode structure 2 is selected, add the following value to W (width).

Nominal Size	25	32, 40, 50	65, 80	100	125
	W	+52.5(2.07)	+52(2.05)	+49(1.93)	+48(1.89)

- *4: When submersible type or option code DHC is selected, waterproof glands and a 30m long cable are attached. Add 9.5kg(20.9lb) to the weight in the table.

F23.EPS

● AXF Standard, AXF150-AXF300, Wafer Type, PFA /Polyurethane Rubber /Natural Soft Rubber /EPDM Rubber Lining

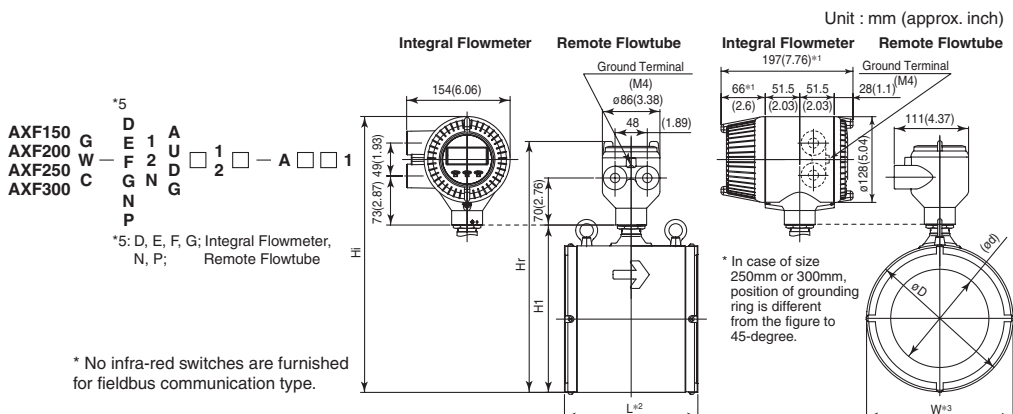

Model	Size code	150	200	250	300	
	Size	150(6)	200(8)	250(10)	300(12)	
	Lining code	A,U D,G	A,U D,G	A,U D,G	A,U D,G	
Remote Flowtube	Face-to-face length	L ^{*2}	200(7.87)	250(9.84)	300(11.81)	350(13.78)
	Outside dia.	øD	202(7.95)	252(9.92)	310(12.20)	358(14.09)
Integral Flowmeter	Inner diameter of Grounding ring	ød	146.1(5.75)	193.6(7.62)	243.7(9.59)	294.7(11.60)
	Width	W ^{*3}	202(7.95)	252(9.92)	310(12.20)	358(14.09)
	Height	H1	243(9.57)	293(11.54)	354(13.94)	402(15.83)
Remote Flowtube	Max. Height	Hr	367(14.45)	417(16.42)	478(18.82)	526(20.71)
	Weight kg (lb) ^{*4}		14.5(32.0)	22.1(48.7)	39.0(86.0)	48.3(106.5)
Integral Flowmeter	Max. Height	Hi	405(15.93)	455(17.89)	516(20.31)	564(22.20)
	Weight kg (lb)		16.2(35.7)	23.8(52.4)	40.7(89.7)	50.0(110.2)

*1: When indicator code N is selected, subtract 12 mm (0.47 inch) from the value in the figure.
In case of explosion proof type with indicator, add 5 mm (0.2 inch) to it.
*2: Depending on the selection of grounding ring code and optional code, add the following value to L (face-to-face length).

Nominal Size: 150 to 200mm			
Grounding Ring Code	S, L, H, V	P, T	N
Option Code	None	+0	+32(1.26) -2(0.08)
	GA, GC, GD (Special Gaskets)	+10(0.39)	+38(1.5)
Nominal Size: 250 to 300mm			
Grounding Ring Code	S, L, H, V	P, T	N
Option Code is "None"	+0	-	-2(0.08)

*3: When electrode structure 2 is selected, add the following value to W(width).

Nominal size	150	200	250	300
W	+49(1.93)	+50(1.97)	+49(1.93)	+53(2.09)

*4: When submersible type or option code DHC is selected, waterproof glands and a 30m long cable are attached. Add 9.5kg(20.9lb) to the weight in the table.

F24.EPS

● AXF Standard, AXF002-AXF010, Weld · Union Joint, Ceramics Lining

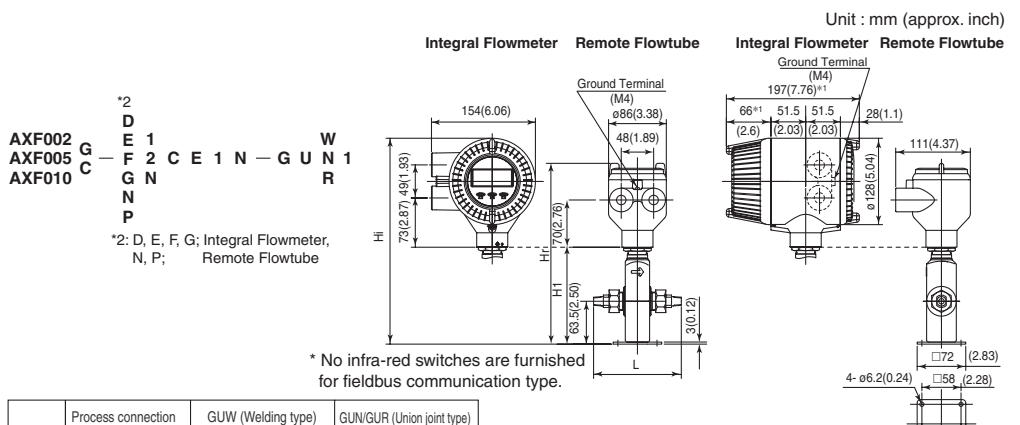

Model	Process connection	GUV (Welding type)			GUN/GUR (Union joint type)		
	Size code	002	005	010	002	005	010
	Size	2.5 (0.1)	5 (0.2)	10 (0.4)	2.5 (0.1)	5 (0.2)	10 (0.4)
	Lining code	C	C	C	C	C	C
Remote flowtube	Face-to-face length	L	140(5.51)			130(5.12)	
	Height	H1	144(5.67)			144(5.67)	
Remote flowtube	Max. Height	Hr	268(10.55)			268(10.55)	
	Weight kg (lb)		2.3(5.1)			2.3(5.1)	
Integral flowmeter	Max. Height	Hi	306(12.03)			306(12.03)	
	Weight kg (lb)		4(8.8)			4(8.8)	

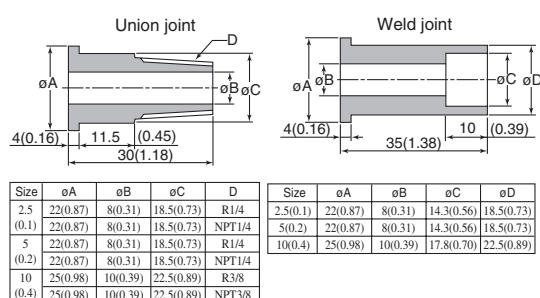

*1: When indicator code N is selected, subtract 12 mm (0.47 inch) from the value in the figure.
In case of explosion proof type with indicator, add 5 mm (0.2 inch) to it.

F25.EPS

● AXF Standard, AXF015, Wafer Type, Ceramics Lining

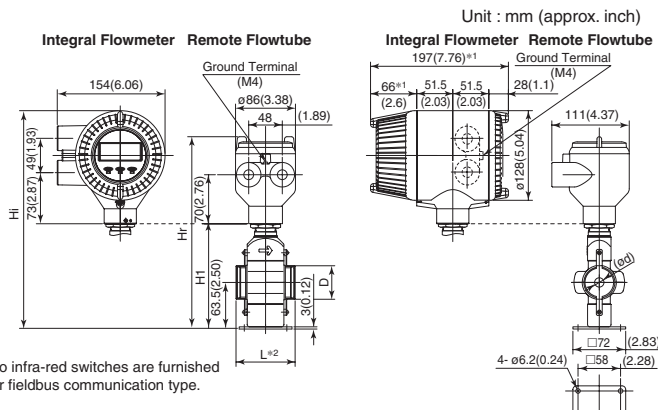
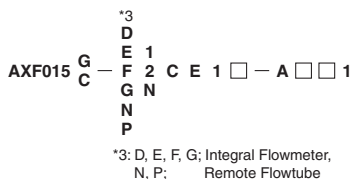

Model	Size code	015	
	Size	15(0.5)	
	Lining code	C	
Remote flowtube	Face-to-face length	L ^{*2}	85(3.35)
	Outside dia.	D	44(1.73)
Integral flowmeter	Inner diameter of Grounding ring	ød	15(0.59)
	Height	H1	144(5.67)
Remote flowtube	Max. Height	Hr	268(10.55)
	Weight kg (lb)	2.3(5.1)	
Integral flowmeter	Max. Height	Hi	306(12.03)
	Weight kg (lb)	4(8.8)	

- *1: When indicator code N is selected, subtract 12 mm (0.47 inch) from the value in the figure. In case of explosion proof type with indicator, add 5 mm (0.2 inch) to it.
- *2: Depending on the selection of grounding ring code and optional code, add the following value to L (face-to-face length).

Grounding Ring Code	S, L, H, V	P, T	N
L(Face-to-face length)	+0	+22(0.87)	-6(0.24)

F26.EPS

● AXF Standard, AXF025-AXF100, Wafer Type, Ceramics Lining

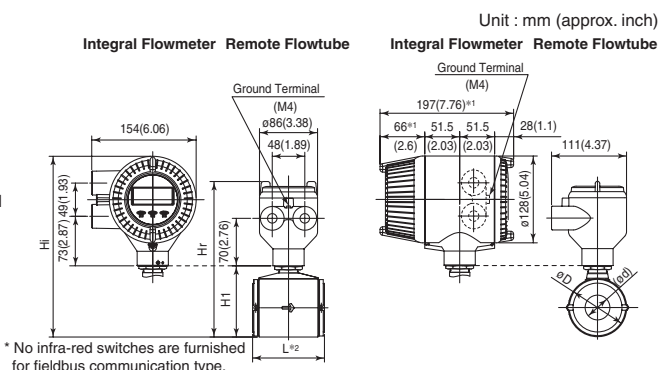
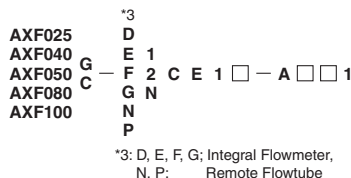

Model	Size code	025	040	050	080	100	
	Size	25(1)	40(1.5)	50(2)	80(3)	100(4)	
	Lining code	C	C	C	C	C	
Remote Flowtube	Face-to-face length	L ^{*2}	93(3.66)	106(4.17)	120(4.72)	160(6.30)	180(7.09)
	Outside dia.	ØD	67.5(2.66)	86(3.39)	99(3.90)	129(5.08)	155(6.10)
Integral Flowmeter	Inner diameter of Grounding ring	ød	27(1.06)	40(1.57)	52(2.05)	81(3.19)	98(3.86)
	Height	H1	92(3.62)	111(4.37)	129(5.08)	159(6.26)	184(7.24)
Remote Flowtube	Max. Height	Hr	216(8.50)	235(9.25)	253(9.96)	283(11.14)	308(12.13)
	Weight kg (lb)	2.3(5.1)		3.2(7.0)	4.1(9.0)	6.8(15.0)	9.6(21.1)
Integral Flowmeter	Max. Height	Hi	254(9.98)	273(10.73)	291(11.44)	321(12.64)	346(13.62)
	Weight kg (lb)	4.0(8.8)		4.9(10.8)	5.8(12.7)	8.5(18.8)	11.3(24.9)

- *1: When indicator code N is selected, subtract 12 mm (0.47 inch) from the value in the figure. In case of explosion proof type with indicator, add 5 mm (0.2 inch) to it.
- *2: Depending on the selection of grounding ring code and optional code, add the following value to L (face-to-face length).

Grounding Ring Code	S, L, H, V	P, T	N
L(Face-to-face length)	+0	+22(0.87)	-6(0.24)

F27.EPS

● AXF Standard, AXF150, AXF200, Wafer Type, Ceramics Lining

*3
D
E 1
AXF150 G — F 2 C E 1 □ — A □ □ 1
AXF200 C — G N
N
P

*3: D, E, F, G; Integral Flowmeter,
N, P; Remote Flowtube

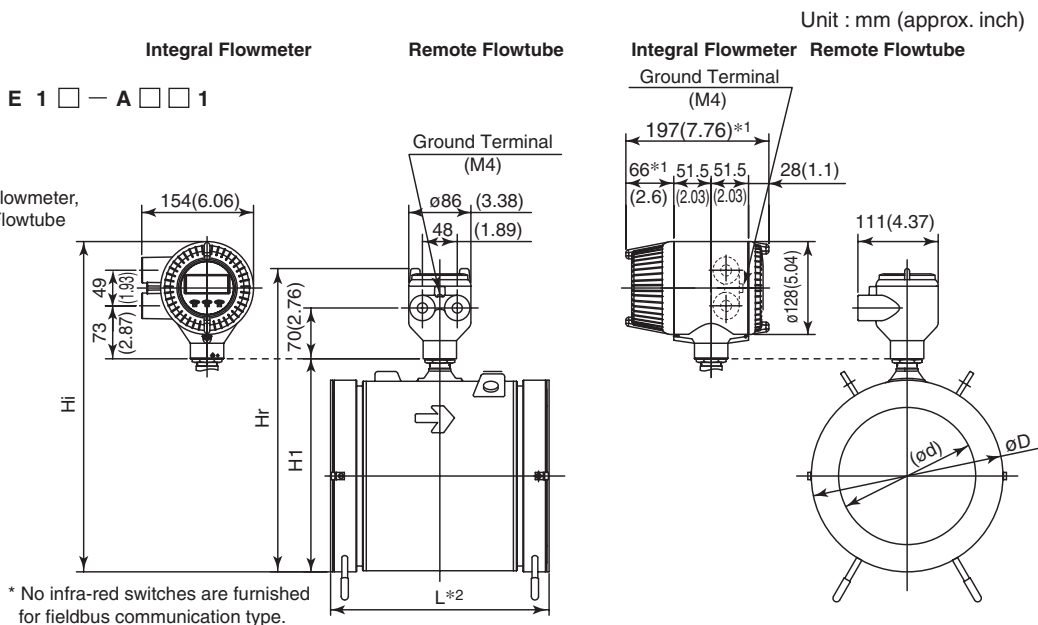

* No infra-red switches are furnished for fieldbus communication type.

Model	Size code	150	200
	Size	150(6)	200(8)
	Lining code	C	C
Remote Flowtube	Face-to-face length	L*2	232(9.13) 302(11.89)
	Outside dia.	D	214(8.43) 264(10.39)
Integral Flowmeter	Inner diameter of Grounding ring	∅d	144(5.67) 192(7.56)
	Height	H1	254(10.00) 304(11.97)
Remote Flowtube	Max. Height	Hr	378(14.88) 428(16.85)
	Weight kg (lb)		20.2(44.5) 33.5(73.9)
Integral Flowmeter	Max. Height	Hi	416(16.36) 466(18.33)
	Weight kg (lb)		21.9(48.3) 35.2(77.6)

*1: When indicator code N is selected, subtract 12 mm (0.47 inch) from the value in the figure.
In case of explosion proof type with indicator, add 5 mm (0.2 inch) to it.
*2: Depending on the selection of grounding ring code and optional code, add the following value to L (face-to-face length).

Grounding Ring Code	S, L, H, V	P, T	N
L(Face-to-face length)	+0	+30(1.18)	-6(0.24)

F28.EPS

● AXF Standard, AXF002-AXF015, JIS/ANSI/DIN/JPI Flange Type, PFA Lininig

Unit : mm (approx. inch)

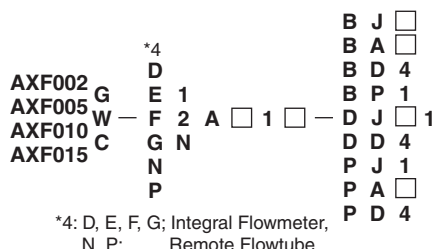
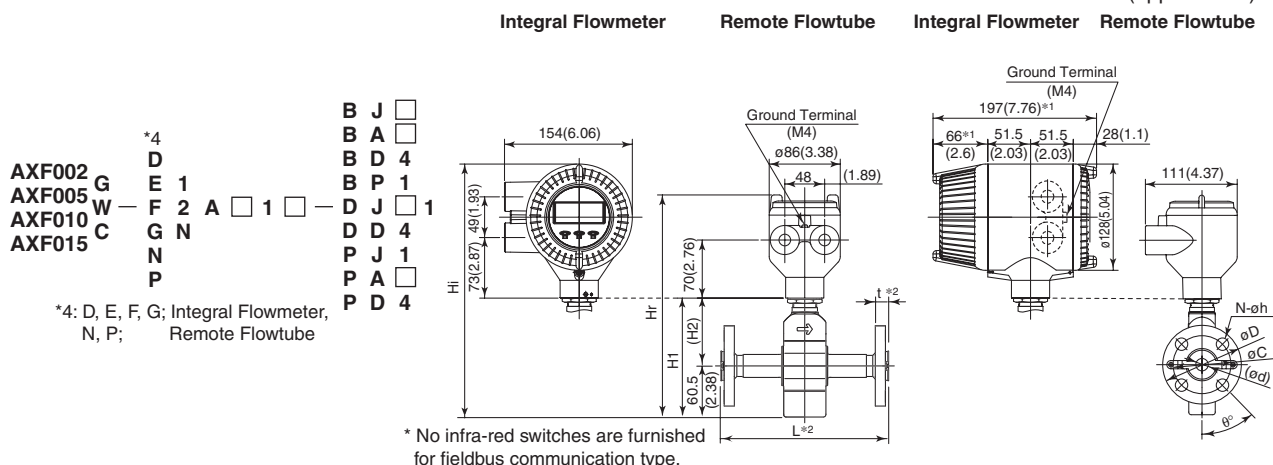

Model	Process Connection	BJ1/PJ1 (JIS10K)			BJ2 (JIS20K)			BA1/PA1 (ANSI Class 150) BP1 (JPI Class 150)			BA2/PA2 (ANSI Class 300)			BD4/PD4 (DIN PN40)			DJ1 (JIS10K)			DJ2 (JIS20K)			DD4 (DIN PN40)																
		002	005	010	015	002	005	010	015	002	005	010	015	002	005	010	015	002	005	010	002	005	010	002	005	010													
	Size	2.5 (0.1)	5 (0.2)	10 (0.4)	15 (0.5)	2.5 (0.1)	5 (0.2)	10 (0.4)	15 (0.5)	2.5 (0.1)	5 (0.2)	10 (0.4)	15 (0.5)	2.5 (0.1)	5 (0.2)	10 (0.4)	15 (0.5)	2.5 (0.1)	5 (0.2)	10 (0.4)	15 (0.5)	2.5 (0.1)	5 (0.2)	10 (0.4)	15 (0.5)														
	Lining code	A	A	A	A	A	A	A	A	A	A	A	A	A	A	A	A	A	A	A	A	A	A	A	A														
Remote Flowtube	Face-to-face length L _s ^{*2}	150(5.91)			150(5.91)			150(5.91)			150(5.91)			150(5.91)			150(5.91)			150(5.91)			150(5.91)																
	Outside dia. øD	95(3.74)			95(3.74)			88.9(3.50)			95.3(3.75)			95(3.74)			90(3.54)			90(3.54)			90(3.54)																
	Thickness t ^{*2}	18 to 22 (0.71 to 0.87)			16 (0.63)			20 to 24 (0.79 to 0.94)			18 (0.71)			17 to 22 (0.67 to 0.87)			15.2 (0.60)			20 to 25 (0.79 to 0.98)			18.2 (0.72)			21 to 25 (0.83 to 0.98)			20 (0.79)										
	Inner diameter of Grounding ring ød	15(0.59)			15(0.59)			15(0.59)			15(0.59)			15(0.59)			12(0.47)			12(0.47)			12(0.47)																
	Pitch circle dia. øC	70(2.76)			70(2.76)			60.5(2.38)			66.5(2.62)			65(2.56)			65(2.56)			65(2.56)			60(2.36)																
Integral Flowmeter	Bolt hole interval θ°	45			45			45			45			45			45			45			45																
	Hole dia. øh	15(0.59)			15(0.59)			15.7(0.62)			15.7(0.62)			14(0.55)			15(0.59)			15(0.59)			14(0.55)																
	Number of holes N	4			4			4			4			4			4			4			4																
Remote Flowtube	Max. Height Hr	265(10.43)			265(10.43)			265(10.43)			265(10.43)			265(10.43)			265(10.43)			265(10.43)			265(10.43)																
	Weight kg (lb) ^{*3}	3.4(7.5)			3.5(7.7)			3.6(7.9)			3.7(8.2)			3.2(7.1)			3.3(7.3)			3.6(7.9)			3.7(8.2)			3.8(8.4)			3.9(8.6)			3.3(7.3)			3.4(7.5)			3.6(7.9)	
Integral Flowmeter	Max. Height Hi	303(11.91)			303(11.91)			303(11.91)			303(11.91)			303(11.91)			303(11.91)			303(11.91)			303(11.91)			303(11.91)													
	Weight kg (lb)	5.1(11.2)			5.2(11.5)			5.3(11.7)			5.4(11.9)			4.9(10.8)			5.0(11.0)			5.3(11.7)			5.4(11.9)			5.5(12.1)			5.6(12.4)			5.0(11.0)			5.1(11.2)			5.3(11.7)	

- *1: When indicator code N is selected, subtract 12 mm (0.47 inch) from the value in the figure. In case of explosion proof type with indicator, add 5 mm (0.2 inch) to it.
- *2: Depending on the selection of grounding ring code and optional code, add the following value to "L" (face-to-face length) and "t" (thickness of flange).

Option Code	None	L		t	
		S, L, H, V	P, T	N	N
Grounding Ring Code					
Option Code					

- *3: When submersible type or option code DHC is selected, waterproof glands and a 30m long cable are attached. Add 9.5kg(20.9lb) to the weight in the table.

● AXF Standard, AXF025-AXF050, JIS/ANSI/DIN/JPI/AS Flange Type, PFA /Polyurethane Rubber /Natural Soft Rubber /EPDM Rubber Lining

Unit : mm (approx. inch)

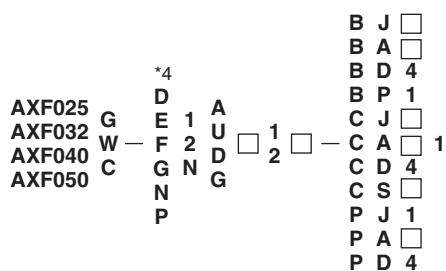

*4: D, E, F, G; Integral Flowmeter, N, P; Remote Flowtube

* No infra-red switches are furnished for fieldbus communication type.

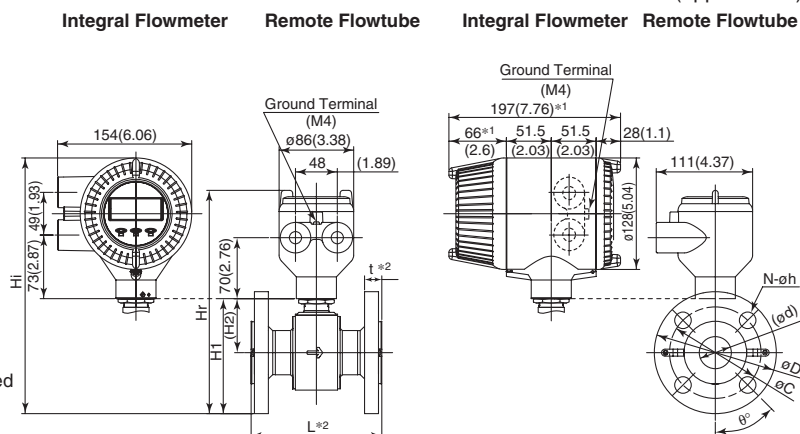

Model	Process Connection	BJ1/PJ1 (JIS10K)				BJ2 (JIS20K)				BA1/PA1 (ANSI Class 150) BP1 (JPI Class 150)				BA2/PA2 (ANSI Class 300)			BA2/CA2/PA2 (ANSI Class 300)				BD4/PD4 (DIN PN40)				BD4/CD4/PD4 (DIN PN40)					
		025	032	040	050	025	032	040	050	025	032	040	050	025	032	040	050	025	032	040	050	025	032	040	050	025	032	040	050	
	Size code	25	32	40	50	25	32	40	50	25	32	40	50	25	32	40	50	25	32	40	50	25	32	40	50	25	32	40	50	
	Lining code ^{*5}	A,U	A,U	A,U	A,U	A,U	A,U	A,U	A,U	A,U	A,U	A,U	A,U	A,U	A,U	A,U	A,U	A,U	A,U	A,U	A,U	A,U	A,U	A,U	A,U	A,U	A,U	A,U	A,U	
Remote Flowtube	Face-to-face length L ₀ ^{*2}	200	200	200	200	200	200	200	200	200	200	200	200	200	200	200	200	200	200	200	200	200	200	200	200	200	200	200	200	200
	Outside dia. øD	125	135	140	155	125	135	140	155	108.0	117.3	127.0	152.4	124.0	133.4	155.4	165.1	115	140	150	165	115	140	150	165	115	140	150	165	165
	Thickness t ^{*2}	18	20	20	20	20	22	22	22	18.2	19.7	21.5	23.1	21.5	23.1	24.6	26.4	22	22	22	24	22	22	22	24	22	22	22	24	24
	Inner diameter of Grounding ring ød	28	34	41	53	28	34	41	53	28	34	41	53	28	34	41	53	28	34	41	53	28	34	41	53	28	34	41	53	53
	Pitch circle dia. øC	90	100	105	120	90	100	105	120	79.2	88.9	98.6	120.7	88.9	98.6	114.3	127.0	85	100	110	125	85	100	110	125	85	100	110	125	125
	Bolt hole interval ø ^o	45	45	45	45	45	45	45	22.5	45	45	45	45	45	45	45	22.5	45	45	45	45	45	45	45	45	45	45	45	45	45
Integral Flowmeter	Hole dia. øH	19	19	19	19	19	19	19	19	15.7	15.7	15.7	19.1	19.1	19.1	22.4	19.1	14	18	18	18	14	18	18	18	14	18	18	18	18
	Number of holes N	4	4	4	4	4	4	4	8	4	4	4	4	4	4	8	4	4	4	4	4	4	4	4	4	4	4	4	4	
	Height H1	120	129	138	157	120	129	138	157	112	120	131	155	120	128	146	162	115	131	143	162	115	131	143	162	115	131	143	162	
Remote Flowtube	Max. Height Hr	244	253	262	281	244	253	262	281	236	244	255	279	244	252	270	286	239	255	267	286	239	255	267	286	239	255	267	286	286
	Weight kg (lb)	4.4 (9.8)	5.3 (11.7)	5.7 (12.6)	6.8 (14.9)	4.8 (10.5)	5.7 (12.6)	6.2 (13.6)	7.0 (15.4)	3.9 (8.5)	4.5 (9.9)	5.4 (11.9)	6.2 (13.8)	7.4 (16.4)	5.0 (11.0)	5.8 (12.9)	7.8 (17.1)	9.0 (19.8)	4.7 (10.4)	6.1 (13.4)	6.9 (15.2)	8.7 (19.2)	4.7 (10.4)	6.1 (13.4)	6.9 (15.2)	8.7 (19.2)	4.7 (10.4)	6.1 (13.4)	6.9 (15.2)	8.7 (19.2)
Integral Flowmeter	Max. Height Hi	114	114	114	114	114	114	114	114	110	110	110	114	114	114	114	114	114	114	114	114	114	114	114	114	114	114	114	114	114
	Weight kg (lb)	6.1 (13.5)	7.0 (15.5)	7.4 (16.4)	8.5 (18.6)	6.5 (14.3)	7.4 (16.4)	7.9 (17.4)	8.7 (19.1)	6.2 (13.6)	6.2 (13.6)	7.1 (15.7)	8.1 (18.0)	9.1 (20.1)	6.7 (14.7)	7.5 (16.6)	9.5 (20.8)	10.7 (23.6)	6.4 (14.1)	7.8 (17.2)	8.6 (19.0)	10.4 (22.9)	6.4 (14.1)	7.8 (17.2)	8.6 (19.0)	10.4 (22.9)	6.4 (14.1)	7.8 (17.2)	8.6 (19.0)	

Model	Process Connection	CS1 (AS Table D)	CS2 (AS Table E)
		Size code	050
	Size ^{*4}	50 (2)	50 (2)
	Lining code ^{*5}	A	A
Remote Flowtube	Face-to-face length L ₀ ^{*2}	200 (7.87)	200 (7.87)
	Outside dia. øD	150 (5.91)	150 (5.91)
	Thickness t ^{*2}	12 (0.47)	14 (0.55)
	Inner diameter of Grounding ring ød	53 (2.09)	53 (2.09)
	Pitch circle dia. øC	49 (1.93)	49 (1.93)
	Integral Flowmeter	Bolt hole interval ø ^o	45
Hole dia. øH		18 (0.71)	18 (0.71)
Number of holes N		4	4
Height H1		154 (6.06)	154 (6.06)
Remote Flowtube	Max. Height Hr	278 (10.95)	278 (10.95)
	Weight kg (lb) ^{*3}	4.9 (10.7)	5.2 (11.5)
Integral Flowmeter	Max. Height Hi	114 (4.5)	114 (4.5)
	Weight kg (lb)	6.6 (14.5)	6.9 (15.3)

- *1: When indicator code N is selected, subtract 12 mm (0.47 inch) from the value in the figure. In case of explosion proof type with indicator, add 5 mm (0.2 inch) to it.
- *2: Depending on the selection of grounding ring code and optional code, add the following value to "L" (face-to-face length) and "t" (thickness of flange).

Grounding Ring Code	S, L, H, V	P, T	L	t
	Option Code	+0	+0	+26(1.02)
			-2(0.08)	-1(0.04)
	+8(0.31)	+4(0.16)	+30(1.18)	+15(0.59)
			-	-

- *3: When submersible type or option code DHC is selected, waterproof glands and a 30m long cable are attached. Add 9.5kg(20.9lb) to the weight in the table.
- *4: In the case of 32 mm (1.25 in.), the following process connection codes are not available. BP1, PJ1, PA1, PA2 and PD4
- *5: In the case of lining code U, D or G, the following process connection codes are not available. BP1, PJ1, PA1, PA2 and PD4

● AXF Standard, AXF065-AXF125, JIS/ANSI/DIN/JPI/AS Flange Type, PFA /Polyurethane Rubber /Natural Soft Rubber /EPDM Rubber Lining

Unit : mm (approx. inch)

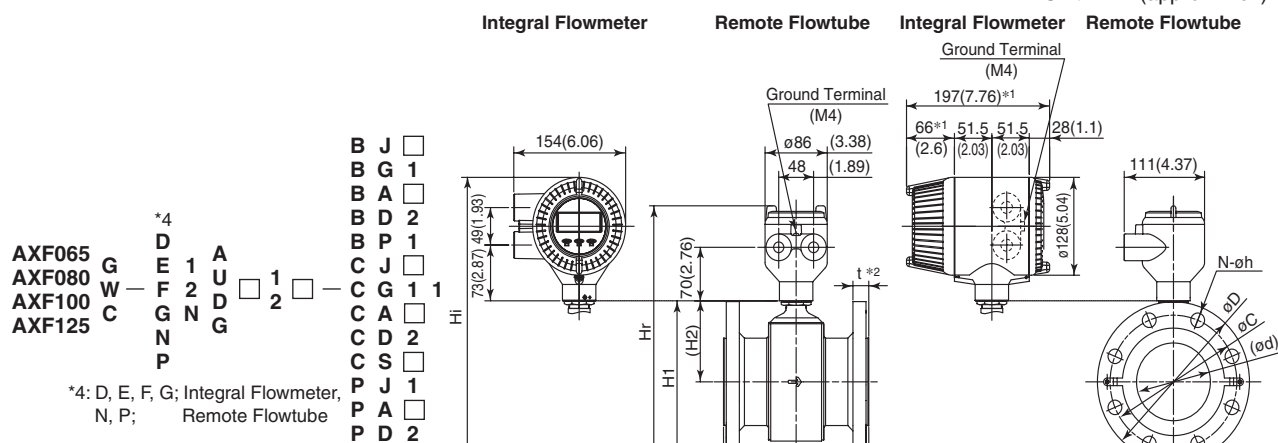

- AXF065 G W — 1 2 — A U D G
 AXF080 G W — 1 2 — A U D G
 AXF100 G W — 1 2 — A U D G
 AXF125 G W — 1 2 — A U D G
- *4: D, E, F, G; Integral Flowmeter, N, P; Remote Flowtube
- B J □
 B A 1 □
 B D 2 □
 B C P 1 □
 C C G 1 1 □
 C C A □
 C C S 2 □
 C C C □
 P J 1 □
 P A □
 P D 2 □

* No infra-red switches are furnished for fieldbus communication type.

Model	Process Connection	BJ1/CJ1/PJ1 (JIS10K)				BJ2/CJ2 (JIS20K)				BG1/CG1 (JIS F12)				BA1/CA1/PA1 (ANSI Class 150) BPI (JPI Class 150)			BA2/CA2/PA2 (ANSI Class 300)			BD2/CD2/PD2 (DIN PN16)				
		065	080	100	125	065	080	100	125	080	100	125	065	080	100	125	065	080	100	125	065	080	100	125
	Size code	65	80	100	125	65	80	100	125	80	100	125	65	80	100	125	65	80	100	125	65	80	100	125
	Size*4	(2.5)	(3)	(4)	(5)	(2.5)	(3)	(4)	(5)	(3)	(4)	(5)	(2.5)	(3)	(4)	(5)	(2.5)	(3)	(4)	(5)	(2.5)	(3)	(4)	(5)
	Lining code*5	A.U	A.U	A.U	A.U	A.U	A.U	A.U	A.U	A.U	A.U	A.U	A.U	A.U	A.U	A.U	A.U	A.U	A.U	A.U	A.U	A.U	A.U	A.U
	Face-to-face length L ₋₃ ⁰⁺²	200	200	250	200	200	250	200	250	200	250	200	200	250	200	250	200	250	200	250	200	250	200	250
	Outside dia. øD	175	185	210	250	175	200	225	270	211	238	263	177.8	190.5	228.6	254.0	190.5	209.6	254.0	279.4	185	200	220	250
	Thickness t*2	22	22	22	24	24	26	28	30	22	24	26.4	27.9	27.9	27.9	29.4	32.4	35.8	39.1	22	24	26	26	26
	Inner diameter of Grounding ring ød	66	77	102	128	66	77	102	128	77	102	128	66	77	102	128	66	77	102	128	66	77	102	128
	Pitch circle dia. øC	140	150	175	210	140	160	185	225	168	195	220	139.7	152.4	190.5	215.9	149.3	168.1	200.2	235.0	145	160	180	210
	Bolt hole interval ø ⁰	45	22.5	22.5	22.5	22.5	22.5	22.5	45	45	30	45	45	22.5	22.5	22.5	22.5	22.5	22.5	45	22.5	45	22.5	22.5
	Hole dia. øh	19	19	23	19	23	19	23	25	19	19	19	19.1	19.1	19.1	22.4	22.4	22.4	22.4	18	18	18	18	18
	Number of holes N	4	8	8	8	8	8	8	8	4	4	6	4	4	8	8	8	8	8	8	4	8	8	8
	Height H1	176	187	211	245	176	195	218	255	200	225	252	177	190	220	247	184	200	233	260	181	195	216	245
	Height H2	89	95	106	120	89	95	106	120	95	106	120	89	95	106	120	89	95	106	120	89	95	106	120
	Max. Height Hr	300	311	335	369	300	319	342	379	324	349	376	301	314	344	371	308	324	357	384	305	319	340	369
	Weight kg (lb) ⁰³	9.0	9.6	12.4	17.4	9.3	12.4	16.9	24.7	12.2	15.5	19.5	10.8	12.9	17.7	20.8	12.6	16.6	26.8	34.9	9.8	11.9	14.5	19.3
	Max. Height Hi	338	349	372	407	338	357	380	417	362	386	413	339	352	380	409	346	362	394	421	343	357	377	407
	Weight kg (lb)	10.7	11.3	14.1	19.1	11.0	14.1	18.6	26.4	13.9	17.2	21.2	12.5	14.6	19.4	22.5	14.3	18.3	28.5	36.6	11.5	13.6	16.2	21.0

Model	Process Connection	CS1 (AS Table D)		CS2 (AS Table E)	
		080	100	080	100
	Size code	80	100	80	100
	Size*4	(3)	(4)	(3)	(4)
	Lining code*5	A	A	A	A
	Face-to-face length L ₋₃ ⁰⁺²	200	250	200	250
	Outside dia. øD	185	215	185	215
	Thickness t*2	14	14	15	17
	Inner diameter of Grounding ring ød	77	102	77	102
	Pitch circle dia. øC	146	178	146	178
	Bolt hole interval ø ⁰	45	45	45	22.5
	Hole dia. øh	18	18	18	18
	Number of holes N	4	4	4	8
	Height H1	188	213	188	213
	Height H2	95	106	95	106
	Max. Height Hr	312	337	312	337
	Weight kg (lb) ⁰³	7.8	10.5	8.1	11.2
	Max. Height Hi	349	375	349	375
	Weight kg (lb)	9.5	12.2	9.8	12.9

*1: When indicator code N is selected, subtract 12 mm (0.47 inch) from the value in the figure.

In case of explosion proof type with indicator, add 5 mm (0.2 inch) to it.

*2: Depending on the selection of grounding ring code and optional code, add the following value to "L" (face-to-face length) and "t" (thickness of flange).

Grounding Ring Code	S, L, H, v		P, T		L		t		
	L	t	L	t	L	t	L	t	
Option Code	None	+0	+0	+26(1.02)	+13(0.51)	-2(0.08)	-1(0.04)	-	-
GA, GC, GD (Special Gaskets)	+8(0.31)	+4(0.16)	+30(1.18)	+15(0.59)	-	-	-	-	

*3: When submersible type or option code DHC is selected, waterproof glands and a 30m long cable are attached.

Add 9.5kg(20.9lb) to the weight in the table.

*4: In the case of 65 mm (2.5 in.) and 125 mm (5 in.), the following process connection codes are not available.

BPI, PJ1, PA1, PA2 and PD2

*5: In the case of lining code U, D or G, the following process connection codes are not available.

BPI, PJ1, PA1, PA2 and PD2

● AXF Standard, AXF150, AXF200, JIS/ANSI/DIN/JPI/AS Flange Type, PFA /Polyurethane Rubber /Natural Soft Rubber /EPDM Rubber Lining

Unit : mm (approx. inch)

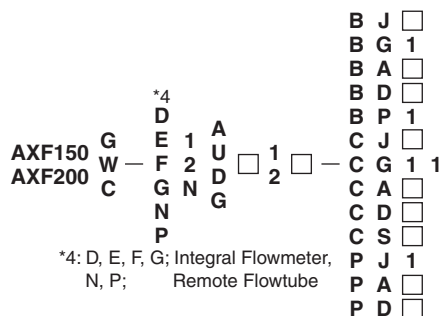

*4: D, E, F, G; Integral Flowmeter, N, P; Remote Flowtube

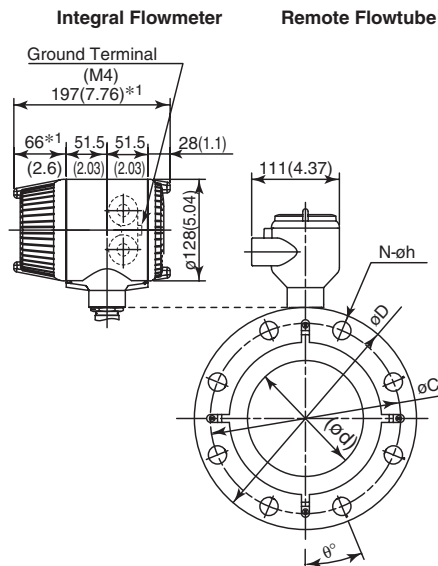
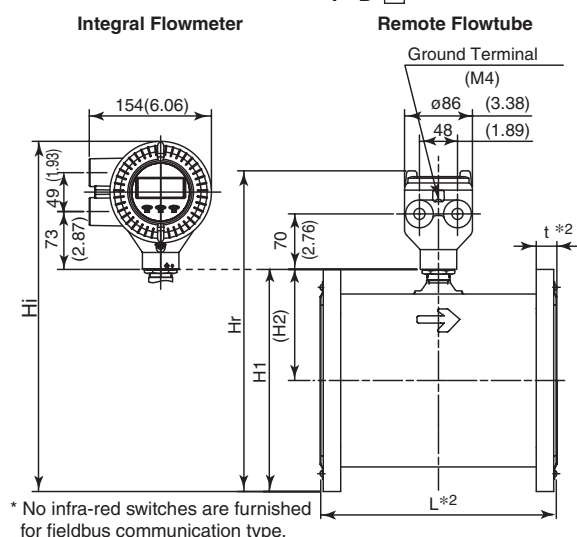

Model	Process Connection	BJ1/CJ1/PJ1 (JIS10K)		BJ2/CJ2 (JIS20K)		BG1/CG1 (JIS F12)		BA1/CA1/PA1 (ANSI Class 150) BP1 (JPI Class 150)		BA2/CA2/PA2 (ANSI Class 300)		BD1/CD1/PD1 (DIN PN10)		BD2/CD2/PD2 (DIN PN16)		CS1 (AS Table D)		CS2 (AS Table E)			
		150	200	150	200	150	200	150	200	150	200	200	150	200	150	200	150	200	150	200	
	Size code	150	200	150	200	150	200	150	200	150	200	200	150	200	150	200	150	200	150	200	
	Size	(6)	(8)	(6)	(8)	(6)	(8)	(6)	(8)	(6)	(8)	(8)	(6)	(8)	(6)	(8)	(6)	(8)	(6)	(8)	
	Lining code *4	A.U D.G	A.U D.G	A.U D.G	A.U D.G	A.U D.G	A.U D.G	A.U D.G	A.U D.G	A.U D.G	A.U D.G	A.U D.G	A.U D.G	A.U D.G	A.U D.G	A	A	A	A		
Remote flowtube	Face-to-face length	L ₀ *2		300		350		300		350		300		350		300		350			
	Outside dia.	øD		280		330		280		342		279.4		342.9		317.5		381.0		340	
	Thickness	t*2		27		33		27		29		30.4		33.4		41.5		46.1		29	
	Inner diameter of Grounding ring	ød		146.1		193.6		146.1		193.6		146.1		193.6		146.1		193.6		146.1	
Integral flowmeter	Pitch circle dia.	øC		240		290		260		305		247		299		241.3		298.5		269.7	
	Bolt hole interval	θ°		22.5		15		15		30		22.5		22.5		22.5		15		15	
	Hole dia.	øh		23		23		25		19		22.4		22.4		22.4		25.4		22	
	Number of holes	N		8		12		12		6		8		8		12		12		8	
Remote flowtube	Height	H1		281		331		294		341		286		337		281		337		300	
	Height	H2		(11.06)		(13.03)		(11.56)		(13.43)		(11.26)		(13.27)		(11.05)		(13.29)		(11.80)	
	Max. Height	Hr		405		455		418		465		410		461		405		461		424	
	Weight kg (lb) *3			27.8		37.3		37.1		51.9		29.9		43.2		30.9		49.2		52.5	
Integral flowmeter	Max. Height	Hi		174.2		193.9		179.5		198.0		176.4		196.5		174.3		196.6		181.7	
	Weight kg (lb)			(65.0)		(86.0)		(85.5)		(118.2)		(69.7)		(99.0)		(71.8)		(112.2)		(119.5)	

- *1: When indicator code N is selected, subtract 12 mm (0.47 inch) from the value in the figure. In case of explosion proof type with indicator, add 5 mm (0.2 inch) to it.
- *2: Depending on the selection of grounding ring code and optional code, add the following value to "L" (face-to-face length) and "t" (thickness of flange).

Option Code	Grounding Ring Code		S, L, H, V		P, T		N	
	None	GA, GC, GD (Special Gaskets)	+0	+0	+32(1.26)	+16(0.63)	-2(0.08)	-1(0.04)
			+10(0.39)	+5(0.20)	+38(1.5)	+19(0.75)	-	-

- *3: When submersible type or option code DHC is selected, waterproof glands and a 30m long cable are attached. Add 9.5kg(20.9lb) to the weight in the table.
- *4: In the case of lining code U, D or G, the following process connection codes are not available. BP1, PJ1, PA1, PA2, PD1 and PD2

F32.EPS

● AXF Standard, AXF250-AXF400, JIS/ANSI/DIN/JPI/AS Flange Type, PFA /Polyurethane Rubber /Natural Soft Rubber /EPDM Rubber Lining

Unit : mm (approx. inch)

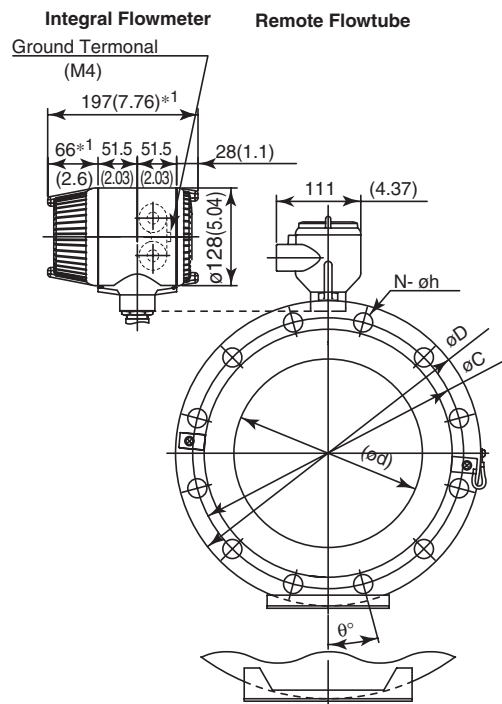
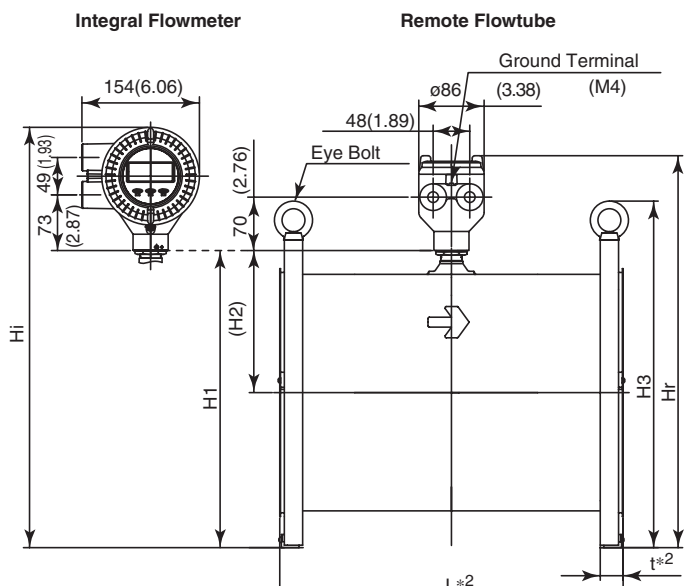
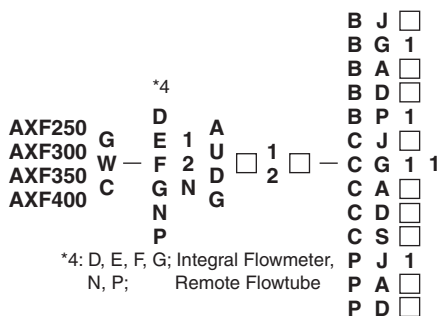

* No infra-red switches are furnished for fieldbus communication type.

for AXF300, AXF350, AXF400

Model	Process Connection	BJ1/CJ1/PJ1 (JIS10K)				BJ2/CJ2 (JIS20K)		BG1/CG1 (JIS F12)				BA1/CA1/PA1 (ANSI Class 150) BP1 (JPI Class 150)				BA2/CA2/PA2 (ANSI Class 300)				BD1/CD1/PD1 (DIN PN10)				BD2/CD2/PD2 (DIN PN16)				CS1 (AS Table D)				CS2 (AS Table E)	
		250	300	350	400	250	300	250	300	350	400	250	300	350	400	250	300	350	400	250	300	350	400	250	300	350	400	250	300	250	300		
	Size code																																
	Size																																
	Lining code*4																																
Remote flowtube	Face-to-face length L _o *2																																
	Outside dia. øD																																
	Thickness t*2																																
	Inner diameter of Grounding ring ød																																
Integral flowmeter	Bolt hole interval ø*																																
	Hole dia. øh																																
	Number of holes N																																
	Height H1																																
Remote flowtube	Max. Height Hi																																
	Weight kg (lb)																																
	Max. Height Hi																																
	Weight kg (lb)																																

- *1: When indicator code N is selected, subtract 12 mm (0.47 inch) from the value in the figure. In case of explosion proof type with indicator, add 5 mm (0.2 inch) to it.
- *2: Depending on the selection of grounding ring code and optional code, add the following value to "L" (face-to-face length) and "t" (thickness of flange).

Nominal Size: 250 mm to 300 mm					Nominal Size: 350 mm to 400 mm				
Grounding Ring Code	S, L, H, V	N	L	t	Grounding Ring Code	S, L, H, V	N	L	t
Option Code is "None"	+0	+0	-6(0.24)	-3(0.12)	Option Code is "None"	+0	+0	-10(0.39)	-5(0.20)

- *3: When submersible type or option code DHC is selected, waterproof glands and a 30m long cable are attached. Add 9.5kg(20.9lb) to the weight in the table.
- *4: In the case of lining code U, D or G, the following process connection code are not available. BP1, PJ1, PA1, PA2, PD1 and PD2

F33.EPS

● AXF Standard, AXF015-AXF125, Sanitary for Clamp Connection, PFA Lining

Unit : mm (approx. inch)

AXF015
 AXF025
 AXF032
 AXF040
 AXF050 H — F 2 A L 1 N — H D B 1
 AXF065
 AXF080
 AXF100
 AXF125

*3: D, E, F, G; Integral Flowmeter,
 N, P; Remote Flowtube

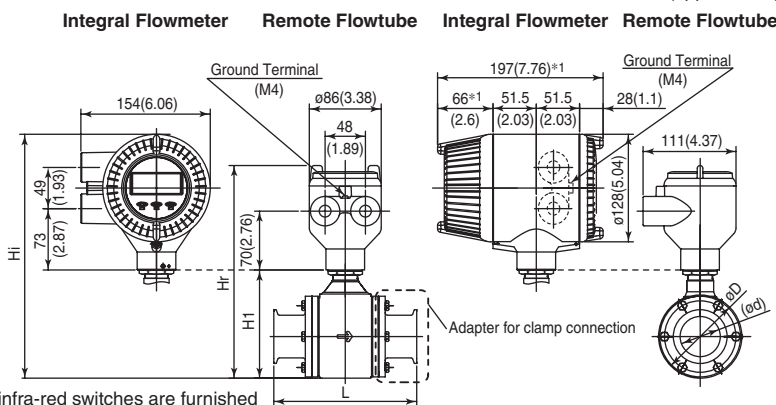

* No infra-red switches are furnished for fieldbus communication type.

Model	Process Connection		HAB / HDB / HKB									
	Size code		015	025	032	040	050	065	080	100	125	
	Size		15 (0.5)	25 (1)	32 (1.3)	40 (1.5)	50 (2)	65 (2.6)	80 (3)	100 (4)	125 (5)	
Lining code		A	A	A	A	A	A	A	A	A		
Remote Flowtube	Face-to-face length	L	166 (6.55)	166 (6.55)	166 (6.55)	166 (6.55)	176 (6.94)	196 (7.73)	216 (8.52)	246 (9.70)	316 (12.46)	
	Outside dia.	øD	73 (2.87)	73 (2.87)	73 (2.87)	86 (3.39)	99 (3.90)	117 (4.61)	129 (5.08)	155 (6.10)	183 (7.20)	
Integral Flowmeter	Inner dia.	ød	HAB 15.7 (0.62)	22.1 (0.87)	—	34.8 (1.37)	47.5 (1.87)	60.2 (2.37)	72.9 (2.87)	97.4 (3.83)	—	
		HDB	16 (0.63)	26 (1.02)	32 (1.26)	38 (1.50)	50 (1.97)	66 (2.60)	81 (3.19)	100 (3.94)	125 (4.92)	
		HKB	15.2 (0.60)	22.6 (0.89)	31.3 (1.23)	35.6 (1.40)	48.6 (1.91)	60.3 (2.37)	72.9 (2.87)	97.6 (3.84)	135.7 (5.34)	
Remote Flowtube	Height	H1	98 (3.86)	98 (3.86)	98 (3.86)	111 (4.37)	129 (5.08)	147 (5.79)	157 (6.18)	183 (7.20)	212 (8.35)	
	Max. Height	Hr	222 (8.74)	222 (8.74)	222 (8.74)	235 (9.25)	253 (9.96)	271 (10.67)	281 (11.06)	307 (12.09)	336 (13.23)	
Integral Flowmeter	Weight kg (lb) ^{*2}	2.7 (6.0)	2.5 (5.5)	2.6 (5.7)	2.9 (6.4)	3.6 (7.9)	4.8 (10.6)	5.7 (12.6)	8.1 (17.9)	12.1 (26.7)		
	Max. Height	Hi	260 (10.22)	260 (10.22)	260 (10.22)	273 (10.73)	291 (11.44)	309 (12.15)	319 (12.54)	345 (13.56)	374 (14.70)	
Remote Flowtube	Weight kg (lb)	4.4 (9.7)	4.2 (9.3)	4.3 (9.5)	4.6 (10.1)	5.3 (11.7)	6.5 (14.3)	7.4 (16.3)	9.8 (21.6)	13.8 (30.4)		

*1: When indicator code N is selected, subtract 12 mm (0.47 inch) from the value in the figure.

*2: When option code DHC is selected, waterproof glands and a 30m long cable are attached. Add 9.5kg(20.9lb) to the weight in the table.

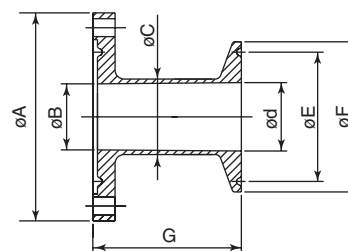

Adapter for clamp connection

Process Connection	HAB (Tri-Clamp)										HDB (DIN 32676 Clamp)										HKB (ISO2852 Clamp)									
	15	25	40	50	65	80	100	15	25	32	40	50	65	80	100	125	15	25	32	40	50	65	80	100	125					
Nominal Size	70 (2.76)	70 (2.76)	83 (3.27)	96 (3.78)	114 (4.49)	126 (4.96)	152 (5.98)	70 (2.76)	70 (2.76)	70 (2.76)	83 (3.27)	96 (3.78)	114 (4.49)	126 (4.96)	152 (5.98)	180 (7.09)	70 (2.76)	70 (2.76)	70 (2.76)	83 (3.27)	96 (3.78)	114 (4.49)	126 (4.96)	152 (5.98)	180 (7.09)					
øA	16 (0.63)	22.2 (0.87)	34.6 (1.36)	47.6 (1.87)	59.5 (2.34)	72.3 (2.85)	97 (3.82)	16 (0.63)	22.2 (0.87)	29.4 (1.16)	34.6 (1.36)	47.6 (1.87)	59.5 (2.34)	72.3 (2.85)	97 (3.82)	123 (4.84)	16 (0.63)	22.2 (0.87)	29.4 (1.16)	34.6 (1.36)	47.6 (1.87)	59.5 (2.34)	72.3 (2.85)	97 (3.82)	123 (4.84)					
øB	19.2 (0.76)	25.4 (1.00)	38.1 (1.50)	50.8 (2.00)	63.5 (2.50)	76.2 (3.00)	101.6 (4.00)	20 (0.79)	30 (1.18)	36 (1.42)	42 (1.65)	54 (2.13)	70 (2.76)	85 (3.35)	104 (4.09)	129 (5.08)	18 (0.71)	25.6 (1.01)	34.3 (1.35)	38.6 (1.52)	51.6 (2.03)	64.1 (2.52)	76.7 (3.02)	102.5 (4.04)	141.2 (5.56)					
øC	15.7 (0.62)	22.1 (0.87)	34.8 (1.37)	47.5 (1.87)	60.2 (2.37)	72.9 (2.87)	97.4 (3.83)	16 (0.63)	22.2 (0.87)	26 (1.02)	32 (1.26)	38 (1.50)	50 (1.97)	66 (2.60)	81 (3.19)	100 (3.94)	15.2 (0.60)	22.6 (0.89)	31.3 (1.23)	35.6 (1.40)	48.6 (1.91)	60.3 (2.37)	72.9 (2.87)	97.6 (3.84)	135.7 (5.34)					
øD	—	43.6 (1.72)	43.6 (1.72)	56.3 (2.22)	70.6 (2.78)	83.3 (3.28)	110.3 (4.34)	27.5 (1.08)	43.5 (1.71)	43.5 (1.71)	43.5 (1.71)	56.5 (2.22)	83.5 (3.29)	97 (3.82)	110 (4.33)	146 (5.75)	27.5 (1.08)	43.5 (1.71)	43.5 (1.71)	56.5 (2.22)	70.5 (2.78)	83.5 (3.29)	110 (4.33)	146 (5.75)						
øE	25 (0.98)	50.4 (1.98)	50.4 (1.98)	64 (2.52)	77.4 (3.05)	91 (3.58)	118.9 (4.68)	34 (1.34)	50.5 (1.99)	50.5 (1.99)	50.5 (1.99)	64 (2.52)	91 (3.58)	106 (4.17)	119 (4.69)	155 (6.10)	34 (1.34)	50.5 (1.99)	50.5 (1.99)	50.5 (1.99)	64 (2.52)	77.5 (3.05)	91 (3.58)	119 (4.69)	155 (6.10)					
G	50 (1.97)	50 (1.97)	50 (1.97)	50 (1.97)	50 (1.97)	50 (1.97)	50 (1.97)	50 (1.97)	50 (1.97)	50 (1.97)	50 (1.97)	50 (1.97)	50 (1.97)	50 (1.97)	50 (1.97)	60 (2.36)	50 (1.97)	50 (1.97)	50 (1.97)	50 (1.97)	50 (1.97)	50 (1.97)	50 (1.97)	50 (1.97)	60 (2.36)					
Parts No.	F9811 HU	F9811 HV	F9811 HX	F9811 HY	F9811 HZ	F9811 JA	F9811 JB	F9811 JD	F9811 JE	F9811 JF	F9811 JG	F9811 JH	F9811 JJ	F9811 JK	F9811 JL	F9811 JM	F9811 JN	F9811 JP	F9811 JQ	F9811 JR	F9811 JS	F9811 JT	F9811 JU	F9811 JV	F9811 JW					

F34.EPS

● AXF Standard, AXF015-AXF125, Sanitary for Union Connection, PFA Lining

Unit : mm (approx. inch)

AXF015
 AXF025 *3
 AXF032 D
 AXF040 E 1 J K B
 AXF050 H — F 2 A L 1 N — J D B 1
 AXF065 G N J S B
 AXF080 N
 AXF100 P
 AXF125

*3: D, E, F, G; Integral Flowmeter,
 N, P; Remote Flowtube

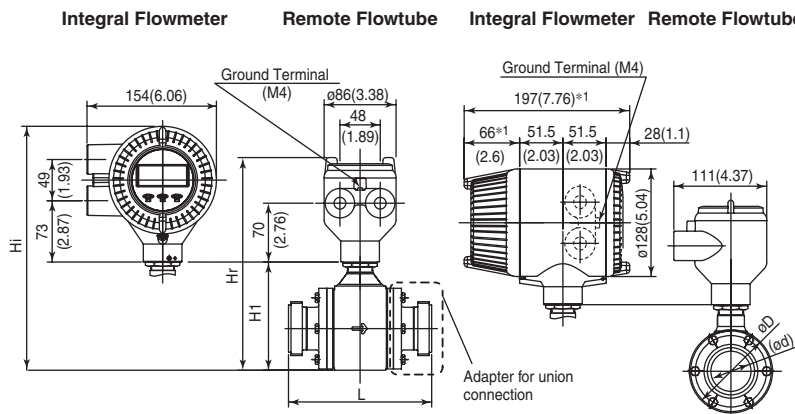

* No infra-red switches are furnished for fieldbus communication type.

Model	Process Connection		JKB / JDB / JSB										
	Size code		015	025	032	040	050	065	080	100	125		
	Size		15 (0.5)	25 (1)	32 (1.3)	40 (1.5)	50 (2)	65 (2.6)	80 (3)	100 (4)	125 (5)		
Lining code		A	A	A	A	A	A	A	A	A			
Remote Flowtube	Face-to-face length	L	JKB	166 (6.55)	166 (6.55)	166 (6.55)	166 (6.55)	176 (6.94)	196 (7.73)	216 (8.52)	246 (9.70)	-	
		JDB	166 (6.55)	166 (6.55)	166 (6.55)	166 (6.55)	176 (6.94)	196 (7.73)	236 (9.31)	266 (10.49)	326 (12.85)	-	
		JSB	-	166 (6.55)	166 (6.55)	166 (6.55)	176 (6.94)	196 (7.73)	216 (8.52)	276 (10.88)	-	-	
Integral Flowmeter	Outside dia.	øD	73 (2.87)	73 (2.87)	73 (2.87)	86 (3.39)	99 (3.90)	117 (4.61)	129 (5.08)	155 (6.10)	183 (7.20)	-	
		Inside dia.	ød	JKB	15.2 (0.60)	22.6 (0.89)	31.3 (1.23)	35.6 (1.40)	48.6 (1.91)	60.3 (2.37)	72.9 (2.87)	97.6 (3.84)	-
				JDB	16 (0.63)	26 (1.02)	32 (1.26)	38 (1.50)	50 (1.97)	66 (2.60)	81 (3.19)	100 (3.94)	125 (4.92)
JSB	-			22.5 (0.89)	29.6 (1.17)	35.5 (1.40)	48.5 (1.91)	60.5 (2.38)	72.9 (2.87)	97.6 (3.84)	-	-	
Remote Flowtube	Height	H1	98 (3.86)	98 (3.86)	98 (3.86)	111 (4.37)	129 (5.08)	147 (5.79)	157 (6.18)	183 (7.20)	212 (8.35)	-	
		Max. Height	Hr	222 (8.74)	222 (8.74)	222 (8.74)	235 (9.25)	253 (9.96)	271 (10.67)	281 (11.06)	307 (12.09)	336 (13.23)	-
		Weight kg (lb)*2	2.6 (5.7)	2.6 (5.7)	2.7 (6.0)	3 (6.6)	3.8 (8.4)	4.9 (10.8)	5.9 (13.0)	8.2 (18.1)	13 (28.7)	13 (28.7)	-
Integral Flowmeter	Max. Height	Hi	260 (10.24)	260 (10.24)	260 (10.24)	273 (10.73)	291 (11.44)	309 (12.17)	319 (12.54)	345 (13.56)	374 (14.70)	-	
		Weight kg (lb)	4.3 (9.5)	4.3 (9.5)	4.4 (9.7)	4.7 (10.4)	5.5 (12.1)	6.6 (14.6)	7.6 (16.8)	9.9 (21.8)	14.7 (32.4)	-	

*1: When indicator code N is selected, subtract 12 mm (0.47 inch) from the value in the figure.

*2: When option code DHC is selected, waterproof glands and a 30m long cable are attached. Add 9.5kg (20.9lb) to the weight in the table.

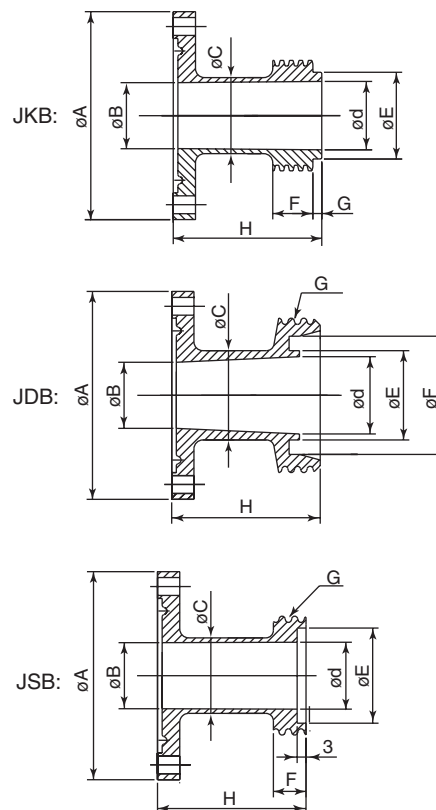

Adapters for union connection

Process Connection	JKB (ISO2853 Union)									JDB (DIN 11851 Union)									JSB (SMS1145 Union)													
	Nominal Size	15	25	32	40	50	65	80	100	15	25	32	40	50	65	80	100	125	25	32	40	50	65	80	100							
øA	70 (2.76)	70 (2.76)	70 (2.76)	83 (3.27)	96 (3.78)	114 (4.49)	126 (4.96)	152 (5.98)	70 (2.76)	70 (2.76)	70 (2.76)	83 (3.27)	96 (3.78)	114 (4.49)	126 (4.96)	152 (5.98)	70 (2.76)	70 (2.76)	83 (3.27)	96 (3.78)	114 (4.49)	126 (4.96)	152 (5.98)	70 (2.76)	70 (2.76)	83 (3.27)	96 (3.78)	114 (4.49)	126 (4.96)	152 (5.98)		
øB	16 (0.63)	22.2 (0.87)	29.4 (1.16)	34.6 (1.36)	47.6 (1.87)	59.5 (2.34)	72.3 (2.85)	97 (3.82)	16 (0.63)	22.2 (0.87)	29.4 (1.16)	34.6 (1.36)	47.6 (1.87)	59.5 (2.34)	72.3 (2.85)	97 (3.82)	123 (4.84)	22.2 (0.87)	29.4 (1.16)	34.6 (1.36)	47.6 (1.87)	59.5 (2.34)	72.3 (2.85)	97 (3.82)	123 (4.84)	22.2 (0.87)	29.4 (1.16)	34.6 (1.36)	47.6 (1.87)	59.5 (2.34)	72.3 (2.85)	97 (3.82)
øC	18 (0.71)	25.6 (1.01)	34.3 (1.35)	38.6 (1.52)	51.6 (2.03)	64.1 (2.52)	76.7 (3.02)	102.5 (4.04)	20 (0.79)	30 (1.18)	36 (1.42)	42 (1.65)	54 (2.13)	70 (2.76)	85 (3.35)	104 (4.09)	129 (5.08)	25.4 (1.00)	32 (1.26)	38.1 (1.50)	51 (2.01)	63.5 (2.50)	76.2 (3.00)	102.5 (4.04)	25.4 (1.00)	32 (1.26)	38.1 (1.50)	51 (2.01)	63.5 (2.50)	76.2 (3.00)	102.5 (4.04)	
ød	15.2 (0.60)	22.6 (0.89)	31.3 (1.23)	35.6 (1.40)	48.6 (1.91)	60.3 (2.37)	72.9 (2.87)	97.6 (3.84)	16 (0.63)	26 (1.02)	32 (1.26)	38 (1.50)	50 (1.97)	66 (2.60)	81 (3.19)	100 (3.94)	125 (4.92)	22.5 (0.89)	29.6 (1.17)	35.5 (1.40)	48.5 (1.91)	60.5 (2.38)	72.9 (2.87)	97.6 (3.84)	22.5 (0.89)	29.6 (1.17)	35.5 (1.40)	48.5 (1.91)	60.5 (2.38)	72.9 (2.87)	97.6 (3.84)	
øE	21.2 (0.83)	29.2 (1.15)	38.2 (1.50)	42.7 (1.68)	56.2 (2.21)	69.9 (2.75)	82.6 (3.25)	108.7 (4.28)	18 (0.71)	30 (1.18)	36 (1.42)	42 (1.65)	54 (2.13)	71 (2.80)	85 (3.35)	104 (4.09)	130 (5.12)	32 (1.26)	40 (1.57)	48 (1.89)	61 (2.40)	73.5 (2.89)	86 (3.39)	120 (4.72)	32 (1.26)	40 (1.57)	48 (1.89)	61 (2.40)	73.5 (2.89)	86 (3.39)	120 (4.72)	
øF	13.5 (0.53)	13.5 (0.53)	13.5 (0.53)	13.5 (0.53)	13.5 (0.53)	13.5 (0.53)	13.5 (0.53)	13.5 (0.53)	25.8 (1.02)	39.8 (1.57)	45.8 (1.80)	51.8 (2.04)	63.8 (2.51)	80.8 (3.18)	94.8 (3.73)	113.8 (4.48)	141.8 (5.58)	11 (0.43)	13 (0.51)	15 (0.59)	15 (0.59)	19 (0.75)	19 (0.75)	30 (1.18)	11 (0.43)	13 (0.51)	15 (0.59)	15 (0.59)	19 (0.75)	19 (0.75)	30 (1.18)	
G	3 (0.12)	3 (0.12)	3 (0.12)	3 (0.12)	3 (0.12)	3 (0.12)	3 (0.12)	3 (0.12)	RD34 x1/8"	RD52 x1/6"	RD58 x1/6"	RD65 x1/6"	RD78 x1/6"	RD95 x1/6"	RD110 x1/4"	RD130 x1/4"	RD160 x1/6"	RD40 x1/6"	RD48 x1/6"	RD60 x1/6"	RD70 x1/6"	RD85 x1/6"	RD98 x1/6"	RD132 x1/6"	RD40 x1/6"	RD48 x1/6"	RD60 x1/6"	RD70 x1/6"	RD85 x1/6"	RD98 x1/6"	RD132 x1/6"	
H	50 (1.97)	50 (1.97)	50 (1.97)	50 (1.97)	50 (1.97)	50 (1.97)	50 (1.97)	50 (1.97)	50 (1.97)	50 (1.97)	50 (1.97)	50 (1.97)	50 (1.97)	50 (1.97)	60 (2.36)	60 (2.36)	65 (2.56)	50 (1.97)	50 (1.97)	50 (1.97)	50 (1.97)	50 (1.97)	50 (1.97)	65 (2.56)	50 (1.97)	50 (1.97)	50 (1.97)	50 (1.97)	50 (1.97)	65 (2.56)		
Parts No.	F9811 LA	F9811 LB	F9811 LC	F9811 LD	F9811 LE	F9811 LF	F9811 LG	F9811 LH	F9811 KH	F9811 KS	F9811 KT	F9811 KU	F9811 KV	F9811 KW	F9811 KX	F9811 KY	F9811 KZ	F9811 LK	F9811 LL	F9811 LL	F9811 LL	F9811 LL	F9811 LL	F9811 LL	F9811 LL	F9811 LL	F9811 LL	F9811 LL	F9811 LL	F9811 LL	F9811 LL	

F35.EPS

● AXF Standard, AXF015-AXF125, Sanitary for Butt Weld, PFA Lining

Unit : mm (approx. inch)

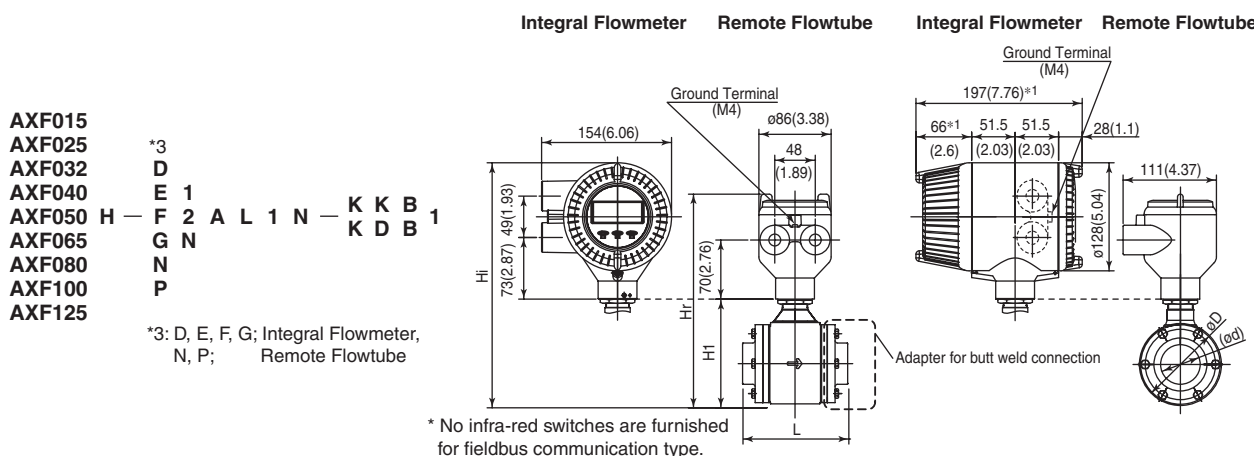

AXF015
 AXF025
 AXF032
 AXF040
 AXF050
 AXF065
 AXF080
 AXF100
 AXF125

*3
 D
 E
 F
 G
 N
 P

H - F 2 A L 1 N - K K B 1
 K D B 1

*3: D, E, F, G; Integral Flowmeter,
 N, P; Remote Flowtube

* No infra-red switches are furnished for fieldbus communication type.

Model	Process Connection		KKB / KDB									
	Size code		015	025	032	040	050	065	080	100	125	
	Size		15 (0.5)	25 (1)	32 (1.3)	40 (1.5)	50 (2)	65 (2.6)	80 (3)	100 (4)	125 (5)	
Lining code			A	A	A	A	A	A	A	A	A	
Remote Flowtube	Face-to-face length	L	126 (4.98)	126 (4.98)	126 (4.98)	126 (4.98)	136 (5.37)	156 (6.16)	176 (6.94)	206 (8.13)	276 (10.88)	
	Outside dia.	øD	73 (2.87)	73 (2.87)	73 (2.87)	86 (3.39)	99 (3.90)	117 (4.61)	129 (5.08)	155 (6.10)	183 (7.20)	
Integral Flowmeter	Inner dia.	ød	KKB	15.2 (0.60)	22.6 (0.89)	31.3 (1.23)	35.6 (1.40)	48.6 (1.91)	60.3 (2.37)	72.9 (2.87)	97.6 (3.84)	135.7 (5.34)
			KDB	16 (0.63)	26 (1.02)	32 (1.26)	38 (1.50)	50 (1.97)	66 (2.60)	81 (3.19)	100 (3.94)	125 (4.92)
Remote Flowtube	Height	H1	98 (3.86)	98 (3.86)	98 (3.86)	111 (4.37)	129 (5.08)	147 (5.79)	157 (6.18)	183 (7.20)	212 (8.35)	
	Max. Height	Hr	222 (8.74)	222 (8.74)	222 (8.74)	235 (9.25)	253 (9.96)	271 (10.67)	281 (11.06)	307 (12.09)	336 (13.23)	
Integral Flowmeter	Weight kg (lb) ^{*2}	2.6 (5.7)	2.3 (5.1)	2.5 (5.5)	2.8 (6.2)	3.4 (7.5)	4.5 (9.9)	5.3 (11.7)	7.1 (15.7)	11 (24.3)		
	Max. Height	Hi	260 (10.24)	260 (10.24)	260 (10.24)	273 (10.73)	291 (11.44)	309 (12.17)	319 (12.54)	345 (13.56)	374 (14.70)	
Integral Flowmeter	Weight kg (lb)	4.3 (9.5)	4 (8.8)	4.2 (9.3)	4.5 (9.9)	5.1 (11.2)	6.2 (13.7)	7 (15.4)	8.8 (19.4)	12.7 (28.0)		

*1: When indicator code N is selected, subtract 12 mm (0.47 inch) from the value in the figure.

*2: When option code DHC is selected, waterproof glands and a 30m long cable are attached. Add 9.5kg (20.9lb) to the weight in the table.

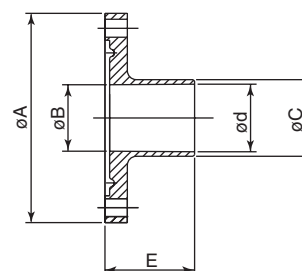

Adapter for butt weld connection

Process Connection	KKB (ISO2037 Butt Weld)									KDB (DIN 1185 Butt Weld)								
	15	25	32	40	50	65	80	100	125	15	25	32	40	50	65	80	100	125
Nominal Size	70 (2.76)	70 (2.76)	70 (2.76)	83 (3.27)	96 (3.78)	114 (4.49)	126 (4.96)	152 (5.98)	180 (7.09)	70 (2.76)	70 (2.76)	70 (2.76)	83 (3.27)	96 (3.78)	114 (4.49)	126 (4.96)	152 (5.98)	180 (7.09)
øA	16 (0.63)	22.2 (0.87)	29.4 (1.16)	34.6 (1.36)	47.6 (1.87)	59.5 (2.34)	72.3 (2.85)	97 (3.82)	123 (4.84)	16 (0.63)	22.2 (0.87)	29.4 (1.16)	34.6 (1.36)	47.6 (1.87)	59.5 (2.34)	72.3 (2.85)	97 (3.82)	123 (4.84)
øB	18 (0.71)	25.6 (1.01)	34.3 (1.35)	38.6 (1.52)	51.6 (2.03)	64.1 (2.52)	76.7 (3.02)	102.5 (4.04)	141.2 (5.56)	20 (0.79)	30 (1.18)	36 (1.42)	42 (1.65)	54 (2.13)	70 (2.76)	85 (3.35)	104 (4.09)	129 (5.08)
øC	15.2 (0.60)	22.6 (0.89)	31.3 (1.23)	35.6 (1.40)	48.6 (1.91)	60.3 (2.37)	72.9 (2.87)	97.6 (3.84)	135.7 (5.34)	16 (0.63)	26 (1.02)	32 (1.26)	38 (1.50)	50 (1.97)	66 (2.60)	81 (3.19)	100 (3.94)	125 (4.92)
ød	30 (1.18)	30 (1.18)	30 (1.18)	30 (1.18)	30 (1.18)	30 (1.18)	30 (1.18)	30 (1.18)	40 (1.57)	30 (1.18)	30 (1.18)	30 (1.18)	30 (1.18)	30 (1.18)	30 (1.18)	30 (1.18)	30 (1.18)	40 (1.57)
E	F9811 NN	F9811 NP	F9811 NQ	F9811 NR	F9811 NS	F9811 NT	F9811 NU	F9811 NV	F9811 NW	F9811 ND	F9811 NE	F9811 NF	F9811 NG	F9811 NH	F9811 NJ	F9811 NK	F9811 NL	F9811 NM

F36.EPS

● Replacement model for Earlier ADMAG or ADMAG AE, AXF002-AXF015, Wafer Type, PFA Lining

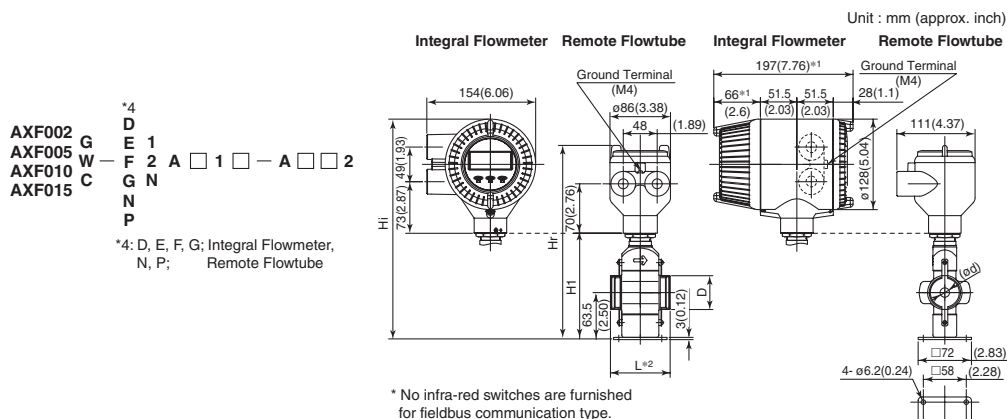

Model	Size code	002	005	010	015
	Size	2.5(0.1)	5(0.2)	10(0.4)	15(0.5)
	Lining code	A	A	A	A
Remote Flowtube	Face-to-face length	L ^{*2} 85(3.35)			
	Outside dia.	D 44(1.73)			
Integral Flowmeter	Inner diameter of Grounding ring	ød 15(0.59)			
	Height	H1 144(5.67)			
Remote Flowtube	Max. Height	Hr 268(10.55)			
	Weight kg (lb) ^{*3}	2.4(5.3)			
Integral Flowmeter	Max. Height	Hi 306(12.03)			
	Weight kg (lb)	4.1(9.0)			

- *1: When indicator code N is selected, subtract 12 mm (0.47 inch) from the value in the figure. In case of explosion proof type with indicator, add 5 mm (0.2 inch) to it.
- *2: Depending on the selection of grounding ring code and optional code, add the following value to L (face-to-face length).

Option Code	Grounding Ring Code	S, L, H, V	P, T	N
	None	+0	+22(0.87)	-6(0.24)
	GA, GC, GD (Special Gaskets)	+2(0.08)	+24(0.94)	-

- *3: When submersible type or option code DHC is selected, waterproof glands and a 30m long cable are attached. Add 9.5kg(20.9lb) to the weight in the table.

F37.EPS

● Replacement model for Earlier ADMAG or ADMAG AE, AXF025-AXF100, Wafer Type, PFA /Polyurethane Rubber Lining

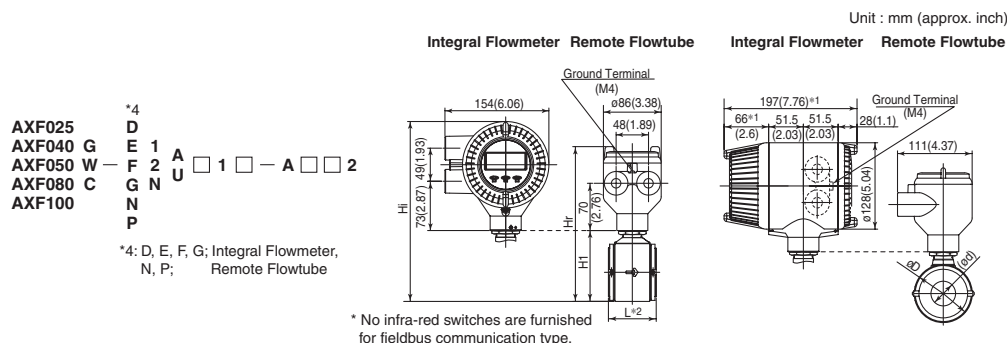

Model	Size code	025	040	050	080	100
	Size	25(1)	40(1.5)	50(2)	80(3)	100(4)
	Lining code	A,U	A,U	A,U	A,U	A,U
Remote Flowtube	Face-to-face length	L ^{*2} 93(3.66) 106(4.17) 120(4.72) 160(6.30) 180(7.09)				
	Outside dia.	øD 67.5(2.66) 86(3.39) 99(3.90) 129(5.08) 155(6.10)				
Integral Flowmeter	Inner diameter of Grounding ring	ød 27(1.06) 40(1.57) 52(2.05) 81(3.19) 98(3.86)				
	Height	H1 92(3.62) 111(4.37) 129(5.08) 157(6.18) 183(7.20)				
Remote Flowtube	Max. Height	Hr 216(8.50) 235(9.25) 253(9.96) 281(11.06) 307(12.09)				
	Weight kg (lb) ^{*3}	3.1(6.7) 3.5(7.7) 4.2(9.3) 6.4(14.1) 8.0(17.6)				
Integral Flowmeter	Max. Height	Hi 254(9.98) 273(10.73) 291(11.44) 319(12.54) 345(13.56)				
	Weight kg (lb)	4.8(10.5) 5.2(11.4) 5.9(13.1) 8.1(17.9) 9.7(21.3)				

- *1: When indicator code N is selected, subtract 12 mm (0.47 inch) from the value in the figure. In case of explosion proof type with indicator, add 5 mm (0.2 inch) to it.
- *2: Depending on the selection of grounding ring code and optional

Option Code	Grounding Ring Code	S, L, H, V	P, T	N
	None	+0	+22(0.87)	-6(0.24)
	GA, GC, GD (Special Gaskets)	+2(0.08)	+24(0.94)	-

- *3: When submersible type or option code DHC is selected, waterproof glands and a 30m long cable are attached. Add 9.5kg(20.9lb) to the weight in the table.

F38.EPS

● Replacement model for Earlier ADMAG or ADMAG AE, AXF150, AXF200, Wafer Type, PFA /Polyurethane Rubber Lining

Unit : mm (approx. inch)

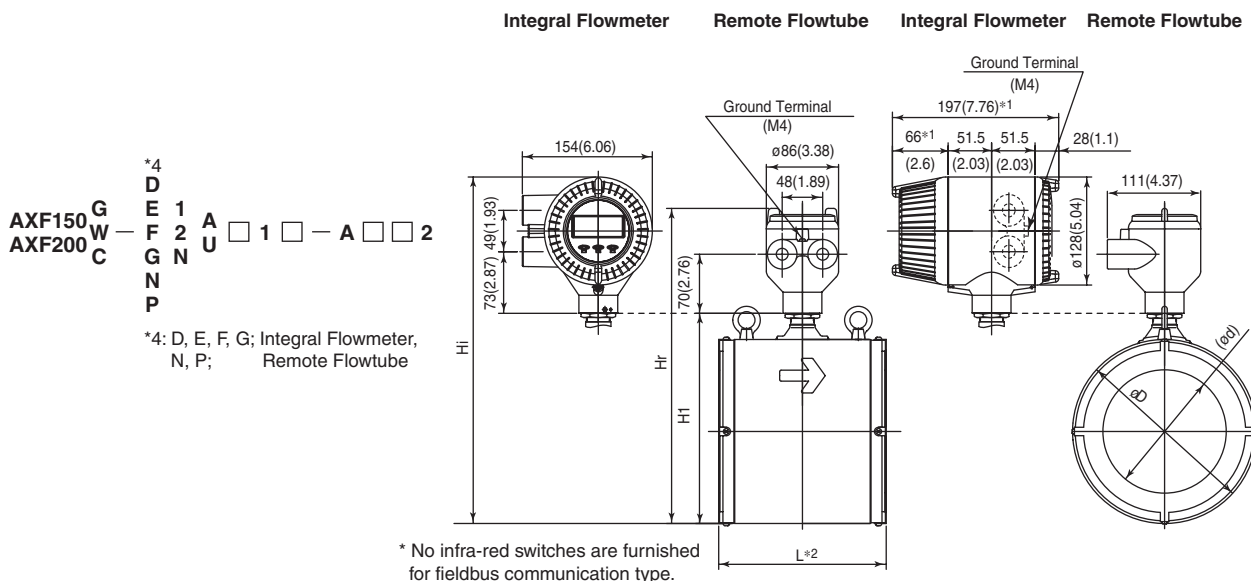

Model	Size code	150	200	
	Size	150(6)	200(8)	
	Lining code	A,U	A,U	
Remote flowtube	Face-to-face length	L*2	230(9.06)	300(11.81)
	Outside dia.	∅D	202(7.95)	252(9.92)
Integral flowmeter	Inner diameter of Grounding ring	∅d	140.7(5.54)	188.9(7.44)
	Height	H1	243(9.57)	293(11.54)
Remote flowtube	Max. Height	Hr	367(14.45)	417(16.42)
	Weight kg (lb)*3		17.9(39.5)	26.8(59.1)
Integral flowmeter	Max. Height	Hi	405(15.93)	455(17.89)
	Weight kg (lb)		19.6(43.2)	28.5(62.8)

*1: When indicator code N is selected, subtract 12 mm (0.47 inch) from the value in the figure.
In case of explosion proof type with indicator, add 5 mm (0.2 inch) to it.

*2: Depending on the selection of grounding ring code and optional code, add the following value to L (face-to-face length).

Option Code	Grounding Ring Code	S, L, H, V	P, T	N
	None	+0	+28(1.1)	-6(0.24)
	GA, GC, GD (Special Gaskets)	+2(0.08)	+30(1.18)	-

*3: When submersible type or option code DHC is selected, waterproof glands and a 30m long cable are attached. Add 9.5kg(20.9lb) to the weight in the table.

F39.EPS

● Replacement model for Earlier ADMAG or ADMAG AE, AXF150-AXF250, JIS/ANSI/DIN Flange Type, PFA /Polyurethane Rubber Lining

*4
 D E F 1
 A X F 2 1 A U □ □ □ □ C J □
 A X F 2 0 0 W — F 2 2 □ □ □ □ C A □ □ □ □ 2
 A X F 2 5 0 C — G N □ □ □ □ C C □ □ □ □
 N P C G 1

*4: D, E, F, G; Integral Flowmeter,
 N, P; Remote Flowtube

Unit : mm (approx. inch)

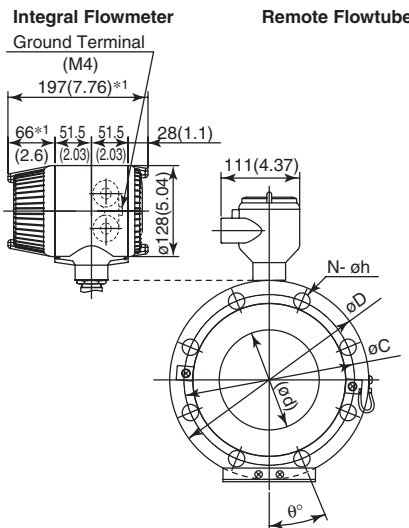
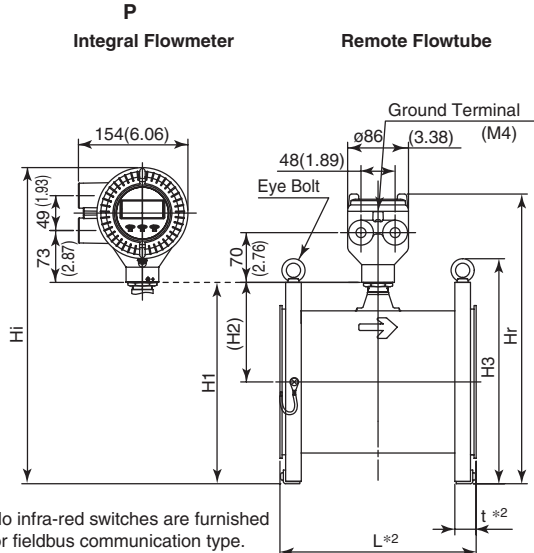

* No infra-red switches are furnished for fieldbus communication type.

Model	Process Connection		CJ1(JIS10K)			CJ2(JIS20K)			CG1(JIS F12)			CA1(ANSI Class 150)			CA2(ANSI Class 300)			CD1(DIN PN10)		CD2(DIN PN16)			
	Size code		150	200	250	150	200	250	150	200	250	150	200	250	150	200	250	200	250	150	200	250	
	Size		150 (6)	200 (8)	250 (10)	150 (6)	200 (8)	250 (10)	150 (6)	200 (8)	250 (10)	150 (6)	200 (8)	250 (10)	150 (6)	200 (8)	250 (10)	200 (8)	250 (10)	150 (6)	200 (8)	250 (10)	
	Lining code		A,U	A,U	A,U	A,U	A,U	A,U	A,U	A,U	A,U	A,U	A,U	A,U	A,U	A,U	A,U	A,U	A,U	A,U	A,U	A,U	A,U
Remote flowtube	Face-to-face length	L*2	270 (10.63)	340 (13.39)	430 (16.93)	270 (10.63)	340 (13.39)	430 (16.93)	270 (10.63)	340 (13.39)	430 (16.93)	270 (10.63)	340 (13.39)	430 (16.93)	270 (10.63)	340 (13.39)	430 (16.93)	340 (13.39)	430 (16.93)	270 (10.63)	340 (13.39)	430 (16.93)	
	Outside dia.	øD	280 (11.02)	330 (12.99)	400 (15.75)	305 (12.01)	350 (13.78)	430 (16.93)	290 (11.42)	342 (13.46)	410 (16.14)	279.4 (11.00)	342.9 (13.50)	406.4 (16.00)	317.5 (12.50)	381.0 (15.00)	444.5 (17.50)	340 (13.39)	395 (15.55)	285 (11.22)	340 (13.39)	405 (15.94)	
	Thickness	t*2	31 (1.22)	31 (1.22)	33 (1.30)	37 (1.46)	39 (1.54)	43 (1.69)	31 (1.22)	33 (1.30)	33 (1.30)	34.4 (1.35)	37.4 (1.47)	39.2 (1.54)	45.5 (1.79)	50.1 (1.97)	56.7 (2.23)	33 (1.30)	35 (1.38)	31 (1.22)	33 (1.30)	35 (1.38)	
	Inner diameter of Grounding ring	ød	140.7 (5.54)	188.9 (7.44)	243 (9.57)	140.7 (5.54)	188.9 (7.44)	243 (9.57)	140.7 (5.54)	188.9 (7.44)	243 (9.57)	140.7 (5.54)	188.9 (7.44)	243 (9.57)	140.7 (5.54)	188.9 (7.44)	243 (9.57)	188.9 (7.44)	243 (9.57)	140.7 (5.54)	188.9 (7.44)	243 (9.57)	
	Pitch circle dia.	øC	240 (9.45)	290 (11.42)	355 (13.98)	260 (10.24)	305 (12.01)	380 (14.96)	247 (9.72)	299 (11.77)	360 (14.17)	241.3 (9.50)	298.5 (11.75)	362.0 (14.25)	269.7 (10.62)	330.2 (13.00)	387.4 (15.25)	295 (11.61)	350 (13.78)	240 (9.45)	295 (11.61)	355 (13.98)	
	Bolt hole interval	θ°	22.5	15	15	15	15	15	30	22.5	22.5	22.5	22.5	15	15	15	11.25	22.5	15	22.5	15	22.5	15
	Hole dia.	øh	23 (0.91)	23 (0.91)	25 (0.98)	25 (0.98)	25 (0.98)	27 (1.06)	19 (0.75)	19 (0.75)	23 (0.91)	22.4 (0.88)	22.4 (0.88)	25.4 (1.00)	22.4 (0.88)	25.4 (1.00)	22.4 (0.88)	25.4 (1.00)	22 (0.87)	22 (0.87)	22 (0.87)	22 (0.87)	26 (1.02)
	Number of holes	N	8	12	12	12	12	12	6	8	8	8	8	8	12	12	12	16	8	12	8	12	12
	Height	H1	284 (11.18)	334 (13.15)	400 (15.75)	297 (11.69)	344 (13.54)	415 (16.34)	289 (11.38)	340 (13.39)	405 (15.94)	284 (11.18)	340 (13.39)	403 (15.87)	303 (11.93)	360 (14.17)	422 (16.61)	339 (13.35)	397 (15.63)	287 (11.30)	339 (13.35)	402 (15.83)	
	Height	H2	141 (5.55)	166 (6.54)	197 (7.76)	141 (5.55)	166 (6.54)	197 (7.76)	141 (5.55)	166 (6.54)	197 (7.76)	141 (5.55)	166 (6.54)	197 (7.76)	141 (5.55)	166 (6.54)	197 (7.76)	141 (5.55)	166 (6.54)	141 (5.55)	166 (6.54)	197 (7.76)	141 (5.55)
Height	H3	325 (12.80)	375 (14.76)	454 (17.87)	350 (13.78)	395 (15.55)	484 (19.06)	335 (13.19)	387 (15.24)	464 (18.27)	324 (12.76)	387 (15.24)	460 (18.11)	362 (14.25)	426 (16.77)	499 (19.65)	385 (15.16)	449 (17.68)	330 (12.99)	385 (15.16)	459 (18.07)		
Remote flowtube	Max. Height	Hr	408 (16.06)	458 (18.03)	524 (20.63)	421 (16.57)	468 (18.43)	539 (21.22)	413 (16.26)	464 (18.27)	529 (20.83)	408 (16.06)	464 (18.27)	527 (20.75)	427 (16.81)	484 (19.06)	546 (21.50)	463 (18.23)	521 (20.51)	411 (16.18)	463 (18.23)	526 (20.71)	
	Weight kg (lb)*3		29 (63.9)	39 (86.0)	64 (141.1)	38.3 (84.4)	53.6 (118.2)	92.5 (203.9)	31.1 (68.6)	44.6 (98.3)	67.4 (148.6)	32.1 (70.7)	50.9 (112.2)	77.4 (170.6)	53.7 (118.4)	80.5 (177.5)	127.0 (279.9)	44.2 (97.5)	67.0 (147.7)	29.9 (65.8)	43.6 (96.2)	68.8 (151.7)	
Integral flowmeter	Max. Height	Hi	446 (17.56)	496 (19.53)	562 (22.13)	459 (18.07)	506 (19.92)	577 (22.72)	451 (17.76)	502 (19.76)	567 (22.32)	446 (17.56)	502 (19.76)	565 (22.24)	465 (18.31)	522 (20.55)	584 (22.99)	501 (19.72)	559 (22.01)	449 (17.68)	501 (19.72)	564 (22.20)	
	Weight kg (lb)		30.7 (67.7)	40.7 (89.7)	65.7 (144.8)	40.0 (88.2)	55.3 (121.9)	94.2 (207.7)	32.8 (72.3)	46.3 (102.1)	69.1 (152.3)	33.8 (74.4)	52.6 (115.9)	79.1 (174.4)	55.4 (122.1)	82.2 (181.2)	128.7 (283.6)	45.9 (101.2)	68.7 (151.5)	31.6 (69.6)	45.3 (100.0)	70.5 (155.5)	

*1: When indicator code N is selected, subtract 12 mm (0.47 inch) from the value in the figure.

In case of explosion proof type with indicator, add 5 mm (0.2 inch) to it.

*2: Depending on the selection of grounding ring code and optional code, add the following value to "L" (face-to-face length) and "t" (thickness of flange).

Nominal Size: 150, 200 mm						
	L	t	L	t	L	t
Grounding Ring Code	S, L, H, V		P, T		N	
Option Code	None	+0	+0	+28(1.1)	+14(0.55)	-6(0.24)
	GA, GC, GD (Special Gaskets)	+2(0.08)	+1(0.04)	+30(1.81)	+15(0.59)	-

Nominal Size: 250 mm				
	L	t	L	t
Grounding Ring Code	S, L, H, V		N	
Option Code is "None"	+0	+0	-6(0.24)	-3(0.12)

*3: When submersible type or option code DHC is selected, waterproof glands and a 30m long cable are attached. Add 9.5kg(20.9lb) to the weight in the table.

● Flameproof Packing Adapter for TIIS Flameproof Type (Optional code G12 or G11)

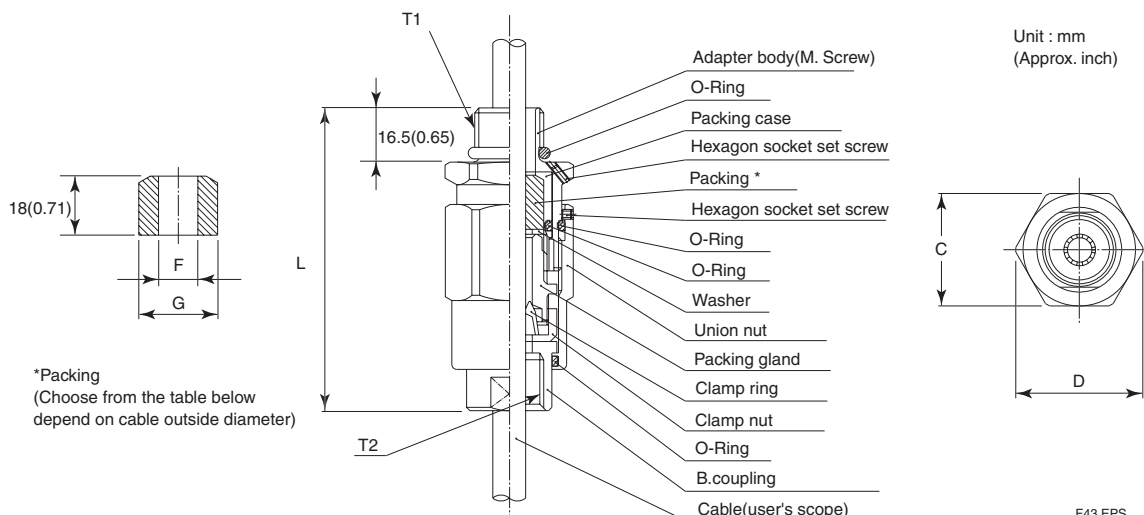

Nominal diameter		Dimension			Cable outer diameter	Packing diameter		Identification mark	Weight kg (lb)	Parts No.
T1	T2	C	D	L		F	G			
G 1/2	G 1/2	35 (1.38)	39 (1.54)	94.5 (3.72)	ø8.0 to ø10.0 (0.31 to 0.39)	ø10.0(0.39)	ø20.0 (0.79)	16 8-10	0.26 (0.57)	G9601AM*
					ø10.0 to ø12.0 (0.39 to 0.47)	ø12.0(0.47)		16 10-12		

*: G 11: 1 unit T31.EPS
G 12: 2 units

● Unless otherwise specified, difference in the dimensions are refer to the following table.

General tolerance in the dimensional outline drawing.

Unit : mm (approx.inch)

Category of basic dimension		Tolerance	Category of basic dimension		Tolerance
Above	Equal or below		Above	Equal or below	
	3 (0.12)	±0.7 (±0.03)	500 (19.69)	630 (24.80)	±5.5 (±0.22)
3 (0.12)	6 (0.24)	±0.9 (±0.04)	630 (24.80)	800 (31.50)	±6.25 (±0.25)
6 (0.24)	10 (0.39)	±1.1 (±0.04)	800 (31.50)	1000 (39.37)	±7.0 (±0.28)
10 (0.39)	18 (0.71)	±1.35 (±0.05)	1000 (39.37)	1250 (49.21)	±8.25 (±0.32)
18 (0.71)	30 (1.18)	±1.65 (±0.06)	1250 (49.21)	1600 (62.99)	±9.75 (±0.38)
30 (1.18)	50 (1.97)	±1.95 (±0.08)	1600 (62.99)	2000 (78.74)	±11.5 (±0.45)
50 (1.97)	80 (3.15)	±2.3 (±0.09)	2000 (78.74)	2500 (98.43)	±14.0 (±0.55)
80 (3.15)	120 (4.72)	±2.7 (±0.11)	2500 (98.43)	3150 (124.02)	±16.5 (±0.65)
120 (4.72)	180 (7.09)	±3.15 (±0.12)			
180 (7.09)	250 (9.84)	±3.6 (±0.14)			
250 (9.84)	315 (12.40)	±4.05 (±0.16)			
315 (12.40)	400 (15.75)	±4.45 (±0.18)			
400 (15.75)	500 (19.69)	±4.85 (±0.19)			

Remarks: The numeric is based on criteria of tolerance class IT18 in JIS B 0401.

■ SIZING DATA (Measurable flow velocity is from 0 m/s.)

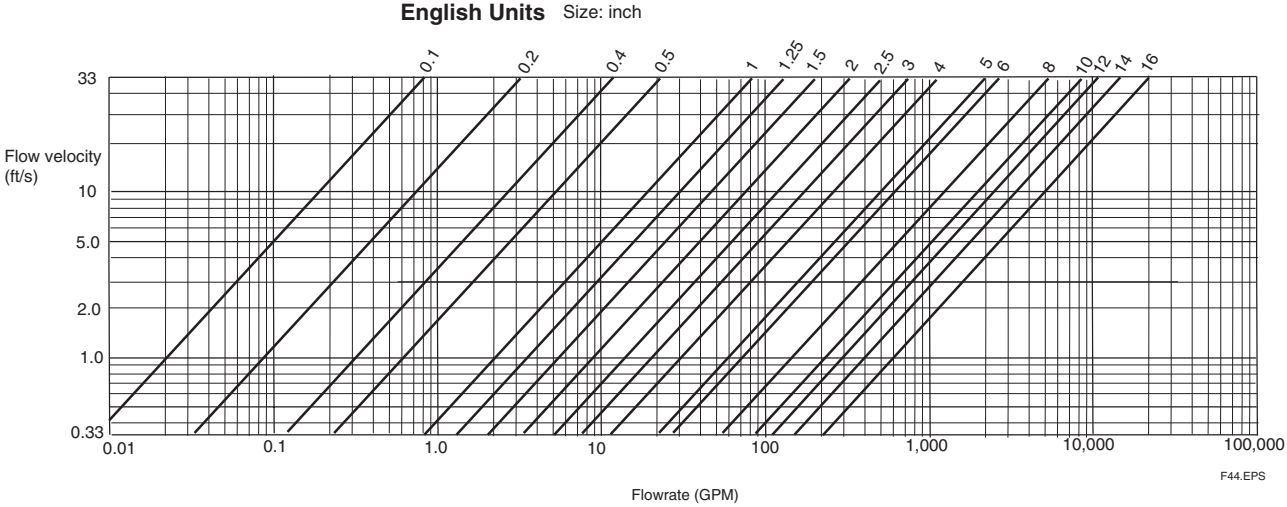
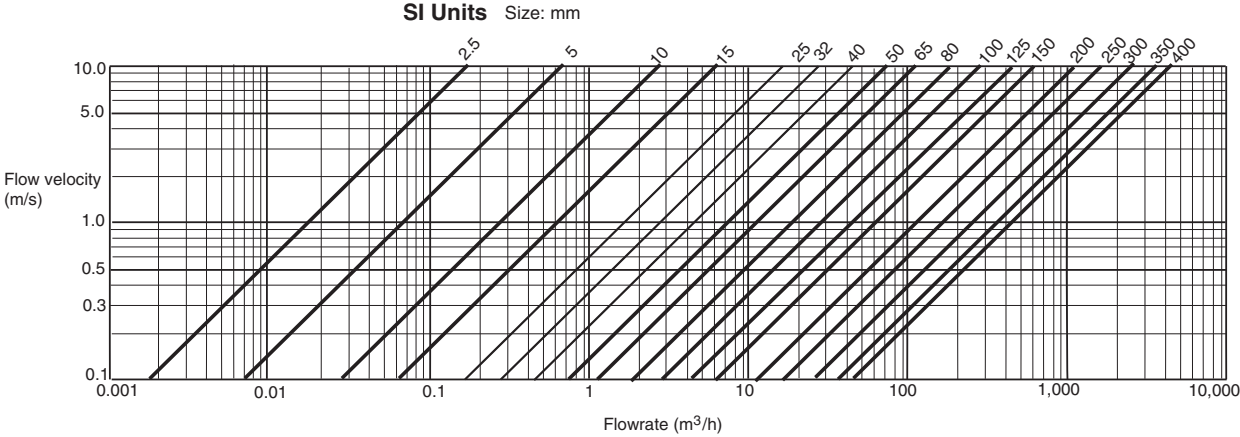

* Measurable flow velocity is from 0 m/s.

7. PED (PRESSURE EQUIPMENT DIRECTIVE)

This chapter describes further requirements and notices concerning the PED (Pressure Equipment Directive). The description in this chapter is prior to other description in this User's Manual.

(1) Technical Data

Module: H

Type of Equipment: Piping

Type of Fluid: Liquids and gas

Group of Fluid: 1 and 2 (*4)

General-purpose Use / Submersible Type / Explosion

Proof Type

MODEL	DN (mm) (*1)	PS (MPa) (*1)	PS DN (MPa · mm)	CATEGORY (*2) (*4)
AXF002G	2.5	4	10	Sound Engineering Practice (SEP) (*3)
AXF002C				
AXF005G	5	4	20	Sound Engineering Practice (SEP) (*3)
AXF005C				
AXF010G	10	4	40	Sound Engineering Practice (SEP) (*3)
AXF010C				
AXF015G	15	4	60	Sound Engineering Practice (SEP) (*3)
AXF015W				
AXF015C				
AXF025G	25	4	100	Sound Engineering Practice (SEP) (*3)
AXF025W				
AXF025C				
AXF032G	32	4	128	II
AXF032W				
AXF032C				
AXF040G	40	4	160	II
AXF040W				
AXF040C				
AXF050G	50	4	200	II
AXF050W				
AXF050C				
AXF065G	65	2	130	II
AXF065W				
AXF065C				
AXF080G	80	2	160	II
AXF080W				
AXF080C				
AXF100G	100	2	200	II
AXF100W				
AXF100C				
AXF125G	125	2	250	II
AXF125W				
AXF125C				
AXF150G	150	2	300	II
AXF150W				
AXF150C				
AXF200G	200	2	400	III
AXF200W				
AXF200C				
AXF250G	250	2	500	III
AXF250W				
AXF250C				
AXF300G	300	2	600	III
AXF300W				
AXF300C				
AXF350G	350	1	350	II
AXF350W				
AXF350C				
AXF400G	400	1	400	III
AXF400W				
AXF400C				

T0701.EPS

Sanitary Type

MODEL	DN (mm) (*1)	PS (MPa) (*1)	PS DN (MPa · mm)	CATEGORY (*2) (*4)
AXF015H	15	1	15	Sound Engineering Practice (SEP) (*3)
AXF025H	25	1	25	Sound Engineering Practice (SEP) (*3)
AXF032H	32	1	32	I
AXF040H	40	1	40	I
AXF050H	50	1	50	I
AXF065H	65	1	65	I
AXF080H	80	1	80	I
AXF100H	100	1	100	I
AXF125H	125	1	125	II

T0702.EPS

*1: PS: Maximum allowable pressure for Flowtube
DN: Nominal size

*2: For details, refer to the following.

Table 6 covered by ANNEX II of Directive 97/23/EC
(until July 18th, 2016)

Table 6 covered by ANNEX II of Directive 2014/68/EU
(from July 19th, 2016)

*3: Article 3, paragraph 3 of Directive 97/23/EC
(until July 18th, 2016)

Article 4, paragraph 3 of Directive 2014/68/EU
(from July 19th, 2016)

*4: Models classified in categories I or II shall not be used for unstable gases of Group 1.

(2) Installation



WARNING

- Tighten the bolts of the piping joints according to the prescribed torque values.
- Take measures to protect the flowmeters from forces caused by vibration channeled through the piping.

(3) Operation



WARNING

- The instrument should be operated with the temperature and pressure of the fluid under normal operating conditions.
- The ambient temperature should be that of normal operating conditions.
- Take measures to prevent excessive pressure such as water hammer, etc. To avoid water hammer prevent the pressure from exceeding the PS (maximum allowable pressure) by setting the system's safety valves, etc. appropriately.
- Should external fire occur, take safety measures at the device itself or system-wide prevent it having an effect on the flowmeters.
- Avoid using fluids exceeding the corrosion proof limitations of the lining and electrodes.
- Take measures not to abrade the metal pipe, and avoid abrading the lining by using fluids such as slurry and sand are contained.

8. EXPLOSION PROTECTED TYPE INSTRUMENT

In this chapter, further requirements and differences for explosion proof type instrument are described.



NOTE

When describing the model name like AXF□□□C in this manual, "□□□" means any of the following.

002, 005, 010, 015, 025, 032, 040, 050, 065, 080, 100, 125, 150, 200, 250, 300, 350, 400



WARNING

Magnetic flowmeters with the model name AXF□□□C are products which have been certified as explosion proof type instruments. Strict limitations are applied to the structures, installation locations, external wiring work, maintenance and repairs, etc. of these instruments. Sufficient care must be taken, as any violation of the limitations may cause dangerous situations.

Be sure to read this chapter before handling the instruments.

For explosion proof type instrument, the description in this chapter is prior to other description in this user's manual.

For ATEX or IECEx explosion proof type, be sure to read IM 01E20A01-11EN.

For TIIS explosion proof type, be sure to read "INSTALLATION AND OPERATING PRECAUTIONS FOR TIIS FLAMEPROOF EQUIPMENT" at the end of this manual.



WARNING

The terminal box cover and display cover is locked by special screw. In case of opening the cover, please use the hexagonal wrench attached.

The covers of explosion proof type products are locked. Use the attached hexagonal wrench to open and close the cover. Before opening the cover, be sure to check that the power of flowmeter has been turned off. Once the cover is closed, be sure to re-lock the product.

Be sure to lock the cover with the special screw using the hexagonal wrench attached after tightening the cover.

8.1 ATEX



NOTE

For ATEX explosion proof type specification, refer to IM 01E20A01-11EN.

8.2 FM

(1) Technical Data

Applicable Standard:

FM3600, FM3610, FM3615,
FM3810, ANSI/NEMA 250

(Integral Flowmeter)

Explosion proof for Class I, Division 1, Groups A, B, C & D.

Dust-ignition proof for Class II/III, Division 1, Groups E, F & G.

Intrinsically safe (electrodes) for Class I, Division 1, Groups A, B, C & D.

"SEAL ALL CONDUITS WITHIN 18 INCHES"

"WHEN INSTALLED IN DIV. 2, SEALS NOT REQUIRED"

Electrode Circuit Um: 250 Vac/dc

Maximum power supply voltage: 250 Vac/130 Vdc

Excitation Circuit: 140V max

Enclosure: NEMA 4X

Temperature Code: T6

Note: Temperature Code T5 to T3 included in the scope of application and its approval.

Refer to following table;

Temperature Code	Maximum Process Temperature	Minimum Process Temperature
T6	+70°C (+158°F)	-40°C (-40°F)
T5	+85°C (+185°F)	-40°C (-40°F)
T4	+120°C (+248°F)	-40°C (-40°F)
T3	+130°C (+266°F)	-40°C (-40°F)

T0813.EPS

Ambient Temp.: -40°C to +60°C (-40°F to +140°F)

(Remote Flowtube)

Explosion proof for Class I, Division 1, Groups A, B, C & D.

Dust-ignition proof for Class II/III, Division 1, Groups E, F & G.

8. EXPLOSION PROTECTED TYPE INSTRUMENT

Intrinsically safe (electrodes) for Class I, Division 1, Groups A, B, C & D.

“SEAL ALL CONDUITS WITHIN 18 INCHES”
 “WHEN INSTALLED IN DIV. 2, SEALS NOT REQUIRED”

Electrode Circuit Um: 250 Vac/dc

Excitation Circuit: 170V max

Enclosure: NEMA 4X

Temperature Code: T6

Note: Temperature Code T5 to T3 included in the scope of application and its approval.

Refer to following table;

Temperature Code	Maximum Process Temperature	Minimum Process Temperature
T6	+70°C (+158°F)	-40°C (-40°F)
T5	+85°C (+185°F)	-40°C (-40°F)
T4	+120°C (+248°F)	-40°C (-40°F)
T3	+150°C (+302°F)	-40°C (-40°F)



T0814.EPS

Ambient Temp.: -40°C to +60°C (-40°F to +140°F)

(2) Electrical Connection



The type of electrical connection is stamped near the electrical connection port according to the following codes.

(Integral Flowmeter)

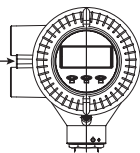
Screw Size	Marking
ISO M20x1.5 female	M 
ANSI 1/2NPT female	N 



(Remote Flowtube)

Screw Size	Marking
ISO M20x1.5 female	M 
ANSI 1/2NPT female	N 



F0806.EPS

(3) Installation



WARNING

- All wiring shall comply with National Electrical Code ANSI/NFPA 70 and Local Electrical Code.
- In hazardous locations, wiring to be in conduit as shown in Figure 8.2.
- When installed in Division 2, “SEALS NOT REQUIRED”

- In case the electrodes and/or grounding rings are made of titanium, the flowtube should be kept away from impacts and frictions in hazardous locations.

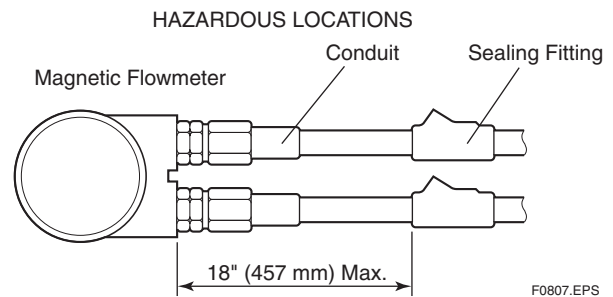

Figure 8.2 Conduit Wiring

F0807.EPS

(4) Operation



WARNING

- “OPEN CIRCUIT BEFORE REMOVING COVERS.”
- “SEALS ALL CONDUITS WITHIN 18 INCHES” in hazardous locations.
- When installed in Division 2, “SEALS NOT REQUIRED”
- Take care not to generate mechanical spark when access to the instrument and peripheral devices in hazardous locations.
- In case the electrodes and/or grounding rings are made of titanium, the flowtube should be kept away from impacts and frictions in hazardous locations.

(5) Maintenance and Repair



WARNING

- The instrument modification or parts replacement by other than authorized representative of Yokogawa Electric Corporation is prohibited and will void the approval of Factory Mutual Research Corporation.
- In case the electrodes and/or grounding rings are made of titanium, the flowtube should be kept away from impacts and frictions in hazardous locations.

8.3 CSA

(1) Technical Data

Applicable Standard:

For CSA C22.2 Series;

C22.2 No 0, C22.2 No 0.4, C22.2 No 0.5,
C22.2 No 25, C22.2 No 30, C22.2 No 94,
C22.2 No 157, C22.2 No.61010-1-12,
C22.2 No.61010-2-030-12

For CSA E79 Series;

CAN/CSA-E79-0, CAN/CSA-E79-1,
CAN/CSA-E79-7, CAN/CSA-E79-11,
CAN/CSA-E79-18

Certificate: 1481213

Process Sealing Certification:

Dual Seal certified by CSA to the requirements of
ANSI/ISA 12.27.01.

No additional sealing required.

Primary seal failure annunciation;

Deterioration of the flowrate output at nonzero
flow point.

Unstable flowrate output at zero flow point.

(Integral Flowmeter) For CSA C22. 2 Series

Explosion proof for Class I, Division 1, Groups A,
B, C & D.

Dust-ignition proof for Class II/III, Division 1,
Groups E, F & G.

Intrinsically safe (electrodes) for Class I, Division 1,
Groups A, B, C & D.

“SEAL ALL CONDUITS WITHIN 50 cm OF THE
ENCLOSURE”

“WHEN INSTALLED IN DIV. 2, SEALS NOT
REQUIRED”

Electrode Circuit Um: 250 Vac/dc

Maximum power supply voltage: 250 Vac/130 Vdc

Excitation Circuit: 140V max

Enclosure: Type 4X

Temperature Code:

Temperature Code	Maximum Process Temperature	Minimum Process Temperature
T6	+70°C (+158°F)	-40°C (-40°F)
T5	+85°C (+185°F)	-40°C (-40°F)
T4	+120°C (+248°F)	-40°C (-40°F)
T3	+130°C (+266°F)	-40°C (-40°F)

T0815.EPS

Ambient Temp.: -40°C to +60°C (-40°F to +140°F)

For CSA E79 Series

Flameproof for Zone 1, Ex dme [ia] IIC T6...T3

Intrinsically safe (electrodes), Ex ia IIC T6...T3

Electrode Circuit Um: 250 Vac/dc

Maximum power supply voltage: 250 Vac/130 Vdc

Excitation Circuit: 140V max

Enclosure: IP66, IP67

Temperature Code:

Temperature Code	Maximum Process Temperature	Minimum Process Temperature
T6	+70°C (+158°F)	-40°C (-40°F)
T5	+85°C (+185°F)	-40°C (-40°F)
T4	+120°C (+248°F)	-40°C (-40°F)
T3	+130°C (+266°F)	-40°C (-40°F)

T0816.EPS

Ambient Temp.: -40°C to +60°C (-40°F to +140°F)

(Remote Flowtube) For CSA C22.2 Series

Explosion proof for Class I, Division 1, Groups A,
B, C & D.

Dust-ignition proof for Class II/III, Division 1,
Groups E, F & G.

Intrinsically safe (electrodes) for Class I, Division 1,
Groups A, B, C & D.

“SEAL ALL CONDUITS WITHIN 50 cm OF THE
ENCLOSURE”

“WHEN INSTALLED IN DIV. 2, SEALS NOT
REQUIRED”

Electrode Circuit Um: 250 Vac/dc

Excitation Circuit: 170V max

Enclosure: Type 4X

Temperature Code:

Temperature Code	Maximum Process Temperature	Minimum Process Temperature
T6	+70°C (+158°F)	-40°C (-40°F)
T5	+85°C (+185°F)	-40°C (-40°F)
T4	+120°C (+248°F)	-40°C (-40°F)
T3	+150°C (+302°F)	-40°C (-40°F)

T0817.EPS

Ambient Temp.: -40°C to +60°C (-40°F to +140°F)

For CSA E79 Series

Flameproof for Zone 1, Ex dme [ia] IIC T6...T3

Intrinsically safe (electrodes), Ex ia IIC T6...T3

Electrode Circuit Um: 250 Vac/dc

Excitation Circuit: 170V max

Enclosure: IP66, IP67

Temperature Code:

Temperature Code	Maximum Process Temperature	Minimum Process Temperature
T6	+70°C (+158°F)	-40°C (-40°F)
T5	+85°C (+185°F)	-40°C (-40°F)
T4	+120°C (+248°F)	-40°C (-40°F)
T3	+150°C (+302°F)	-40°C (-40°F)

T0818.EPS

Ambient Temp.: -40°C to +60°C (-40°F to +140°F)

(2) Installation

For CSA C22.2 Series

WARNING

- All wiring shall comply with Canadian Electrical Code Part I and Local Electrical Codes.
- In hazardous location, wiring shall be in conduit as shown in Figure 8.3

WARNING : SEAL ALL CONDUITS WITHIN 50cm OF THE ENCLOSURE'.
UN SCELLEMENT DOIT ÊTRE INSTALLÉ À MOINS DE 50cm DU BOÎTIER.

- When installed in Division 2, "SEALS NOT REQUIRED"

For CSA E79 Series

WARNING

- All wiring shall comply with local installation requirements and local electrical code.
- In hazardous locations, the cable entry devices shall be of a certified flameproof type, suitable for the conditions of use and correctly installed.
- Unused apertures shall be closed with suitable flameproof certified blanking elements. (The plug attached is flameproof certified.)

(3) Operation

For CSA C22.2 Series

WARNING

WARNING : OPEN CIRCUIT BEFORE REMOVING COVER.

OUVRIR LE CIRCUIT AVANT D'ENLEVER LE COUVERCLE.

- Take care not to generate mechanical spark when access to the instrument and peripheral devices in hazardous locations.

For CSA E79 Series

(Integral Flowmeter)

WARNING

WARNING : AFTER DE-ENERGIZING, DELAY 20 MINUTES BEFORE OPENING. APRÈS POWER-OFF, ATTENDRE 20 MINUTES AVANT D'OUVRIR.

- Take care not to generate mechanical spark when access to the instrument and peripheral devices in hazardous locations.

(Remote Flowtube)

WARNING

WARNING : DE-ENERGIZE BEFORE OPENING.

OUVRIR LE CIRCUIT AVANT D'ENLEVER LE COUVERCLE.

- Take care not to generate mechanical spark when access to the instrument and peripheral devices in hazardous locations.

(4) Maintenance and Repair

WARNING

The instrument modification or parts replacement by other than authorized representative of YOKOGAWA Electric Corporation or YOKOGAWA Corporation of AMERICA is prohibited and will void Canadian Standards Explosionproof Certification.

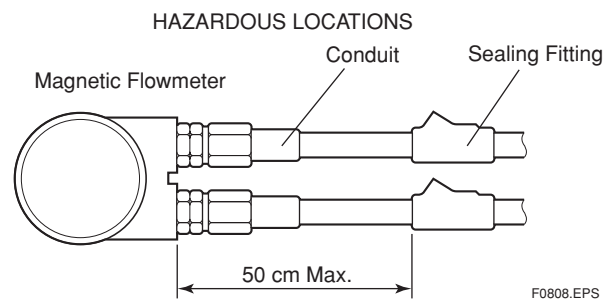

Figure 8.3 Conduit Wiring

8.4 IECEx



NOTE

For IECEx explosion proof type specification, refer to IM 01E20A01-11EN.

8.5 TIIS



CAUTION

The model AXF□□□C magnetic flowmeter with optional code JF3, which has obtained certification according to technical criteria for explosion-protected construction of electric machinery and equipment (Standards Notification No. 556 from the Japanese Ministry of Labor) conforming to IEC standards, is designed for hazardous areas where inflammable gases or vapors may be present. (This allows installation in Division 1 and 2 areas) To preserve the safety of flameproof equipment requires great care during mounting, wiring, and piping. Safety requirements also place restrictions on maintenance and repair activities. Users absolutely must read "INSTALLATION AND OPERATING PRECAUTIONS FOR TIIS FLAMEPROOF EQUIPMENT" at the end of this manual.

(1) Technical Data

Certificate:

Wafer Type;

Lining / Process Connection code Size: mm (inch)	Integral Flowmeter		Remote Flowtube	
	PFA Lining	Ceramics Lining	PFA Lining	Ceramics Lining
	-A**	-A**	-A**	-A**
2.5 (0.1)	TC18966	TC16645	TC18982	TC16669
5 (0.2)	TC18966	TC16645	TC18982	TC16669
10 (0.4)	TC18966	TC16645	TC18982	TC16669
15 (0.5)	TC18966	TC16646	TC18982	TC16670
25 (1.0) (Lay length code 1)	TC16631	TC16647	TC16655	TC16671
25 (1.0) (Lay length code 2)	TC18967	—	TC18983	—
32 (1.25)	TC16632	—	TC16656	—
40 (1.5)	TC16633	TC16648	TC16657	TC16672
50 (2.0)	TC16634	TC16649	TC16658	TC16673
65 (2.5)	TC16635	—	TC16659	—
80 (3.0)	TC16636	TC18978	TC16660	TC18994
100 (4.0)	TC16637	TC18979	TC16661	TC18995
125 (5.0)	TC16638	—	TC16662	—
150 (6.0)	TC18968	TC18980	TC18984	TC18996
200 (8.0)	TC18970	TC18981	TC18986	TC18997
250 (10)	TC18972	—	TC18988	—
300 (12)	TC18974	—	TC18990	—
350 (14)	—	—	—	—
400 (16)	—	—	—	—

T0831.EPS

Flange Type (PFA lining only);

Lining / Process Connection code Size: mm (inch)	Integral Flowmeter	Remote Flowtube
	PFA Lining	PFA Lining
	-B**, -D**	-B**, -D**
2.5 (0.1)	TC18966	TC18982
5 (0.2)	TC18966	TC18982
10 (0.4)	TC18966	TC18982
15 (0.5)	TC18966	TC18982
25 (1.0)	TC16631	TC16655
32 (1.25)	TC16632	TC16656
40 (1.5)	TC16633	TC16657
50 (2.0)	TC16634	TC16658
65 (2.5)	TC16635	TC16659
80 (3.0)	TC16636	TC16660
100 (4.0)	TC16637	TC16661
125 (5.0)	TC16638	TC16662
150 (6.0)	TC18969	TC18985
200 (8.0)	TC18971	TC18987
250 (10)	TC18973	TC18989
300 (12)	TC18975	TC18991
350 (14)	TC18976	TC18992
400 (16)	TC18977	TC18993

T0832.EPS

(Integral Flowmeter)

- Construction: Ex def[ia] IIC T4
 : Converter ; Explosion proof
 Flowtube ; Increased Safety and
 Intrinsically Safety(ia)
 Electrode ; Intrinsically Safety(ia)
 Um=250VAC 50/60Hz, 250VDC,
 Uo=250V*, Io=3.37mA*, Po=0.211W
 *Uo and Io are rms value.
- Gas Group and Temperature Class: IIC T4
- Ambient Temperature: -20 to 60°C (power supply code 1)
 : -20 to 50°C (power supply code 2)
- Fluid Temperature: 120°C max
- Electrode Circuit: 250 V AC/DC
- Maximum power supply voltage: 250V AC/130V DC
- Grounding: JIS Class C(grounding resistance 10Ω or less) or JIS Class A(grounding resistance 10Ω or less)

! WARNING

In case that ambient temperature exceeds 50°C, use heat-resistant cables with maximum allowable temperature of 70°C or above.

(Remote Flowtube)

- Construction: Ex def[ia] IIC T4
 : Terminal box ; Explosion proof
 Flowtube; Increased Safety and
 Intrinsically Safety(ia)
 Electrode; Intrinsically Safety(ia)
 Um=250VAC 50/60Hz, 250VDC,
 Uo=250V*, Io=3.37mA*, Po=0.211W
 *Uo and Io are rms value.
- Gas Group and Temperature Class: IIC T4
- Ambient Temperature: -20 to 60°C
- Fluid Temperature: 120°C max
- Electrode Circuit: 250 V AC/DC
- Grounding: JIS Class C(grounding resistance 10Ω or less) or JIS Class A(grounding resistance 10Ω or less)

! WARNING

In case of TIIS Flameproof type, a remote flowtube is available for combined use with the AXFA14 converter only.

! WARNING

In case that ambient temperature exceeds 50°C, use heat-resistant cables with maximum allowable temperature of 70°C or above.

(2) Wiring Installation

For the external wiring of flameproof types, use a flameproof packing adapter approved by Yokogawa (refer to Figure 8.4.2) or cable wiring using a flameproof metal conduit (refer to Figure 8.4.4 and “INSTALLATION AND OPERATING PRECAUTIONS FOR TIIS FLAMEPROOF EQUIPMENT” at the end of this manual).

! NOTE

This section describes the integral flowmeter as an example. The same attention must be paid to the remote flowtube.

(2-1) Wiring Cable through Flameproof Packing Adapter

! WARNING

For the TIIS flameproof type with wiring using a flameproof packing adapter, wire cables through the packing adapters approved by Yokogawa (optional code G12 or G11).

In case that optional code G11 is selected, it comes with a blanking plug. Then always apply it to the unused wiring port.

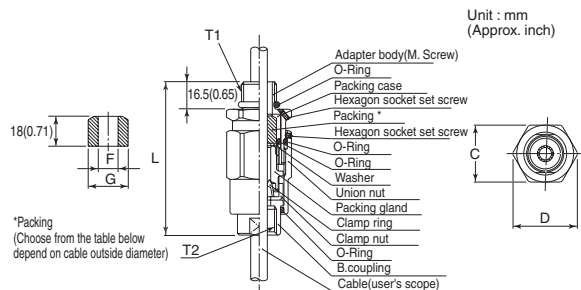

Nominal diameter		Dimension			Cable outer diameter		Packing diameter		Identification mark	Weight kg (lb)	Parts No.
T1	T2	C	D	L	F	G					
G 1/2	G 1/2	35 (1.38)	39 (1.54)	94.5 (3.72)	φ8.0 to φ10.0 (0.31 to 0.39)	φ10.0(0.39)	φ20.0	16	8-10	0.26 (0.57)	G9601AM*
					φ10.0 to φ12.0 (0.39 to 0.47)	φ12.0(0.47)	(0.79)	16	10-12		

*: G 11: 1 unit
 G 12: 2 units
 F0814.EPS

Figure 8.4.1 Flameproof Packing Adapter

- Apply a non-hardening sealant to the terminal box connection port and to the threads on the flameproof packing adapter for waterproofing.
- Either a flameproof packing adapter or a blanking plug must be applied to every wiring port. In case that optional code G11 is selected, it comes with a blanking plug. Then always apply it to the unused wiring port.

If the blanking plug is necessary, always purchase it (parts number: G9330DP) from Yokogawa.

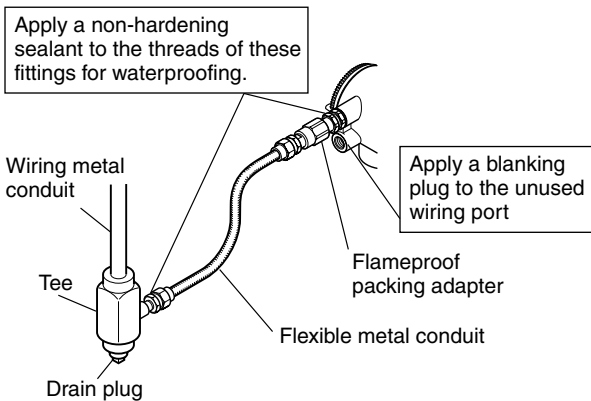

F0815.EPS

Figure 8.4.2 Typical Wiring Using Flexible Metal Conduit

Follow the procedure below when a flameproof packing adapter (optional code G12 or G11) is applied. Refer to Figure 8.4.3.

If a blanking plug is applied, follow the same procedure when the flameproof packing adapter is applied.

CAUTION

Before tightening, confirm cable length from terminal to flameproof packing adapter when setting. Once it is tightened, loosening and re-tightening may damage its sealing performance.

- Loosen the locking screw and remove the terminal box cover.
- Measure the cable outer diameter in two directions to within 0.1 mm.
- Calculate the average of the two diameters, and use packing with an internal diameter nearest to this value (see the table of Figure 8.4.1).
- Screw the flameproof packing adapter into the terminal box until the O-ring touches the wiring port (at least 6 full turns), and firmly tighten the lock nut.
- Insert the cable through the union cover, the union coupling, the clamp nut, the clamp ring, the gland, the washer, the rubber packing, and the packing box, in that order.
- Insert the end of the cable into the terminal box.
- Tighten the union cover to grip the cable. When tightening the union cover, tighten approximately one turn past the point where the cable will no longer move up and down.

Proper tightening is important. If it is too tight, a circuit break in the cable may occur; if not tight enough, the flameproof effectiveness will be compromised.

- Fasten the cable by tightening the clamp nut.
- Tighten the lock nut on the union cover.
- Connect the cable wires to each terminal.

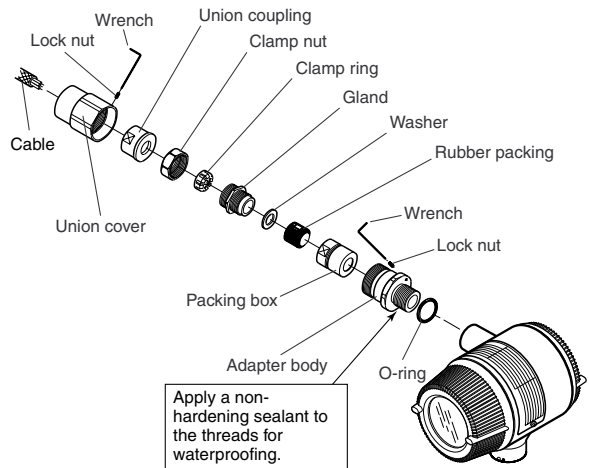

F0816.EPS

Figure 8.4.3 Installing Flameproof Packing Adapter

(2-2) Cable Wiring Using Flameproof Metal Conduit

- A seal fitting must be installed near the terminal box connection port for a sealed construction.
- Apply a non-hardening sealant to the threads of the terminal box connection port, flexible metal conduit and seal fitting for waterproofing.
- Every wiring port must apply the same wiring as Figure 8.4.4.

Apply a blanking plug to the unused wiring port of a 24V power supply version when a four-wire cable is used for both power input and signal output.

If the blanking plug is necessary, always purchase it (parts number: G9330DP) from Yokogawa.

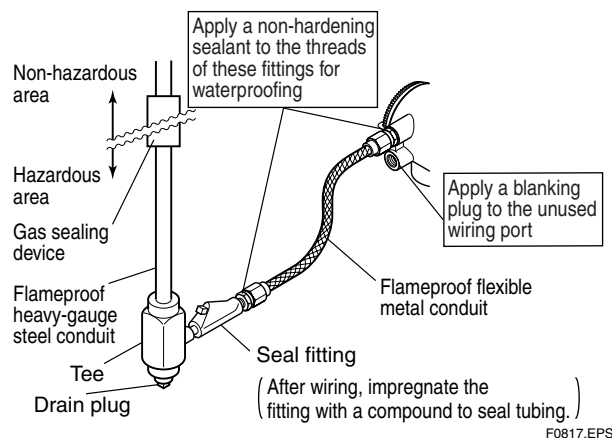

F0817.EPS

Figure 8.4.4 Typical Wiring Using Flameproof Metal Conduit

INSTALLATION AND OPERATING PRECAUTIONS FOR TIIS FLAMEPROOF EQUIPMENT

Apparatus Certified Under Technical Criteria (IEC-compatible Standards)

1. General

The following describes precautions on electrical apparatus of flameproof construction (hereinafter referred to as flameproof apparatus) in explosion-protected apparatus.

Following the Labour Safety and Health Laws of Japan, flameproof apparatus is subjected to type tests to meet either the technical criteria for explosionproof electrical machinery and equipment (standards notification no. 556 from the Japanese Ministry of Labour) (hereinafter referred to as technical criteria), in conformity with the IEC Standards, or the "Recommended Practice for Explosion-Protected Electrical Installations in General Industries," published in 1979. These certified apparatus can be used in hazardous locations where explosive or inflammable gases or vapours may be present.

Certified apparatus includes a certification label and an equipment nameplate with the specifications necessary for explosion requirements as well as precautions on explosion protection. Please confirm these precautionary items and use them to meet specification requirements.

For electrical wiring and maintenance servicing, please refer to "Internal Wiring Rules" in the Electrical Installation Technical Standards as well as "USER'S GUIDELINES for Electrical Installations for Explosive Gas Atmospheres in General Industry," published in 1994.

To meet flameproof requirements, equipment that can be termed "flameproof" must:

- (1) Be certified by a Japanese public authority in accordance with the Labour Safety and Health Laws of Japan and have a certification label in an appropriate location on its case, and
- (2) Be used in compliance with the specifications marked on its certification label, equipment nameplate and precautionary information furnished.

2. Electrical Apparatus of Flameproof Type of Explosion-Protected Construction

Electrical apparatus which is of flameproof construction is subjected to a type test and certified by the Japanese Ministry of Labour aiming at preventing explosion caused by electrical apparatus in a factory or any location where inflammable

gases or vapours may be present. The flameproof construction is of completely enclosed type and its enclosure shall endure explosive pressures in cases where explosive gases or vapours entering the enclosure cause explosion. In addition, the enclosure construction shall be such that flame caused by explosion does not ignite gases or vapours outside the enclosure.

In this manual, the word "flameproof" is applied to the flameproof equipment combined with the types of protection "e", "o", "i", and "d" as well as flameproof equipment.

3. Terminology

(1) Enclosure

An outer shell of an electrical apparatus, which encloses live parts and thus is needed to configure explosion-protected construction.

(2) Shroud

A component part which is so designed that the fastening of joint surfaces cannot be loosened unless a special tool is used.

(3) Enclosure internal volume

This is indicated by:— the total internal volume of the flameproof enclosure minus the volume of the internal components essential to equipment functions.

(4) Path length of joint surface

On a joint surface, the length of the shortest path through which flame flows from the inside to outside of the flameproof enclosure. This definition cannot be applied to threaded joints.

(5) Gaps between joint surfaces

The physical distance between two mating surfaces, or differences in diameters if the mating surfaces are cylindrical.

Note: The permissible sizes of gaps between joint surfaces, the path length of a joint surface and the number of joint threads are determined by such factors as the enclosure's internal volume, joint and mating surface construction, and the explosion classification of the specified gases and vapours.

4. Installation of Flameproof Apparatus

(1) Installation Area

Flameproof apparatus may be installed, in accordance with applicable gases, in a hazardous area in Zone 1 or 2, where the specified gases are present. Those apparatus shall not be installed in a hazardous area in Zone 0.

Note: Hazardous areas are classified in zones based upon the frequency of the appearance and the duration of an explosive gas atmosphere as follows:

Zone 0: An area in which an explosive gas atmosphere is present continuously or is present for long periods.

Zone 1: An area in which an explosive gas atmosphere is likely to occur in normal operation.

Zone 2: An area in which an explosive gas atmosphere is not likely to occur in normal operation and if it does occur it will exist for a short period only.

(2) Environmental Conditions

The standard environmental condition for the installation of flameproof apparatus is limited to an ambient temperature range from -20°C to $+40^{\circ}\text{C}$ (for products certified under Technical Criteria). However, some field-mounted instruments may be certified at an ambient temperature up to $+60^{\circ}\text{C}$ as indicated on the instrument nameplates. If the flameproof apparatus are exposed to direct sunshine or radiant heat from plant facilities, appropriate thermal protection measures shall be taken.

5. External Wiring for Flameproof Apparatus

Flameproof apparatus require cable wiring or flameproof metal conduits for their electrical connections. For cable wiring, cable glands (cable entry devices for flameproof type) to wiring connections shall be attached. For metal conduits, attach sealing fittings as close to wiring connections as possible and completely seal the apparatus. All non-live metal parts such as the enclosure shall be securely grounded. For details, see the "USER'S GUIDELINES for Electrical Installations for Explosive Gas Atmospheres in General Industry," published in 1994.

(1) Cable Wiring

- Specific cables shall be used as recommended by the "USER'S GUIDELINES for Electrical Installations for Explosive Gas Atmospheres in General Industry," published in 1994.
- In necessary, appropriate protective pipes (conduit or flexible pipes), ducts or trays shall be used for preventing the cable run (outside the cable glands) from damage.
- To prevent explosive atmosphere from being propagated from Zone 1 or 2 hazardous location to any different location or non-hazardous location through the protective pipe or duct, apply sealing of the protective pipes in the vicinity of individual boundaries, or fill the ducts with sand appropriately.
- When branch connections of cables, or cable connections with insulated cables inside the conduit pipes are made, a flameproof or increased-safety connection box shall be used. In this case, flameproof or increased-safety cable glands meeting the type of connection box must be used for cable connections to the box.

(2) Flameproof Metal Conduit Wiring

- For the flameproof metal conduit wiring or insulated wires shall be used as recommended by the USER'S GUIDELINES for Electrical Installations for Explosive Gas Atmospheres in General Industry, published in 1994.
- For conduit pipes, heavy-gauge steel conduits conforming to JIS C 8305 Standard shall be used.
- Flameproof sealing fittings shall be used in the vicinity of the wiring connections, and those fittings shall be filled with sealing compounds to complete sealing of the apparatus. In addition, to prevent explosive gases, moisture, or flame caused by explosion from being propagated through the conduit, always provide sealing fittings to complete sealing of the conduit in the following locations:
 - (a) In the boundaries between the hazardous and non-hazardous locations.
 - (b) In the boundaries where there is a different classification of hazardous location.
- For the connections of the apparatus with a conduit pipe or its associated accessories, G-type parallel pipe threads (JIS B 0202) shall be used to provide a minimum of five-thread engagement to complete tightness. In addition, since these parallel threads do not have sealing property, nonhardening sealant such as liquid gaskets shall thus be applied to those threads for ensuring waterproofness.
- If metal conduits need flexibility, use flameproof flexible fittings.

6. Maintenance of Flameproof Apparatus

To maintain the flameproof apparatus, do the following. (For details, see Chapter 10 “MAINTENANCE OF EXPLOSION-PROTECTED ELECTRICAL INSTALLATION” in the USER’S GUIDELINES for Electrical Installations for Explosive Gas Atmospheres in General Industry.)

(1) Maintenance servicing with the power on.

Flameproof apparatus shall not be maintenance-serviced with its power turned on. However, in cases where maintenance servicing is to be conducted with the power turned on, with the equipment cover removed, always use a gas detector to check that there is no explosive gas in that location. If it cannot be checked whether an explosive gas is present or not, maintenance servicing shall be limited to the following two items:

- (a) Visual inspection
Visually inspect the flameproof apparatus, metal conduits, and cables for damage or corrosion, and other mechanical and structural defects.
- (b) Zero and span adjustments
These adjustments should be made only to the extent that they can be conducted from the outside without opening the equipment cover. In doing this, great care must be taken not to cause mechanical sparks with tools.

(2) Repair

If the flameproof apparatus requires repair, turn off the power and transport it to a safety (non-hazardous) location. Observe the following points before attempting to repair the apparatus.

- (a) Make only such electrical and mechanical repairs as will restore the apparatus to its original condition. For the flameproof apparatus, the gaps and path lengths of joints and mating surfaces, and mechanical strength of enclosures are critical factors in explosion protection. Exercise great care not to damage the joints or shock the enclosure.
- (b) If any damage occurs in threads, joints or mating surfaces, inspection windows, connections between the transmitter and terminal box, shrouds or clamps, or external wiring connections which are essential in flameproofness, contact Yokogawa Electric Corporation.



CAUTION

Do not attempt to re-process threaded connections or refinish joints or mating surfaces.

- (c) Unless otherwise specified, the electrical circuitry and internal mechanisms may be repaired by component replacement, as this will not directly affect the

requirements for flameproof apparatus (however, bear in mind that the apparatus must always be restored to its original condition). If you attempt to repair the flameproof apparatus, company-specified components shall be used.

- (d) Before starting to service the apparatus, be sure to check all parts necessary for retaining the requirements for flameproof apparatus. For this, check that all screws, bolts, nuts, and threaded connections have properly been tightened.

(3) Prohibition of specification changes and modifications

Do not attempt to change specifications or make modifications involving addition of or changes in external wiring connections.

7. Selection of Cable Entry Devices for Flameproof Type



CAUTION

The cable glands (cable entry devices for flameproof type) conforming to IEC Standards are certified in combination with the flameproof apparatus. So, Yokogawa-specified cable entry devices for flameproof type shall be used to meet this demand.

References:

- (1) Type Certificate Guide for Explosion-Protected Construction Electrical Machinery and Equipment (relating to Technical Standards Conforming to International Standards), issued by the Technical Institution of Industrial Safety, Japan
- (2) USER’S GUIDELINES for Electrical Installations for Explosive Gas Atmospheres in General Industry (1994), issued by the Japanese Ministry of Labour, the Research Institute of Industrial Safet

REVISION RECORD

Title: AXF Magnetic Flowmeter Integral Flowmeter/Remote Flowtube
 [Hardware Edition]
 Manual No.: IM 01E20D01-01E

Edition	Date	Page	Revised Item
6th	Oct. 2005	3-22 to 3-24 5-1 5-5 6-7 6-12 6-14 6-21 to 6-27 6-28 6-29 6-31 6-39 6-40 6-48 8-7 to 8-8	(7) Added the "Confirmation of adapter mounting screw" Added the sentence. Added the note of installation Added the note of permeable fluids to the grounding ring/grounding electrode. Added the "IECEX" to the hazardous area classification. Added the "SF2 (IECEX)" to the withstand voltage. Changed the note for wetted parts material. MU Changed description of the "mass unit setting (MU)". PM Changed the value of the mirror finished PFA lining (PM). Changed from "Ra 0.05 to 0.15 μm" to "Size 15 to 200 mm : Ra 0.05 to 0.15 μm, Size 250 to 400 mm : Ra 0.05 to 0.25 μm" SF2 Added the "IECEX Certification (SF2)" to the optional specifications. Corrected the "Weight kg (lb)" of BD4. Corrected the "Weight kg (lb)" of BJ1/CJ1, BJ2/CJ2 and BG1/CG1. Corrected the "Inner diameter of grounding ring (ød)" of size 250mm. 8.5 Added the "IECEX".
7th	June 2006	1-1 3-11 3-12 3-13 3-16 3-17 3-18 3-22 3-23 3-24 4-3 4-6 4-13 5-5 5-8 5-9 5-10 6-1, 14, 20, 28 6-7 6-17 to 20 6-21 to 6-23 6-25 to 6-27 6-34 to 6-48	Added the postscript about FOUNDATION Fieldbus protocol type. Table 3.3.7 Changed the Torque Value. Table 3.3.8 Changed the Torque Value. Table 3.3.9 Changed the Torque Value. Table 3.3.14 Changed the Torque Value. Table 3.3.15 Changed the Torque Value. Table 3.3.16 Changed the Torque Value. 5) Added the sentence. 5) Added the sentence. 5) Added the sentence. Changed the Figure 3.3.10. (2) Added the postscript about FOUNDATION Fieldbus protocol type. (6) Added the postscript about FOUNDATION Fieldbus protocol type. 1), 2) Added the "IECEX". 5.3 Added the CAUTION. Changed the Figure 5.3.1. 5.4.3 Added the postscript about FOUNDATION Fieldbus protocol type. 5.5.1 Added the postscript about FOUNDATION Fieldbus protocol type. 5.5.2 Added the postscript about FOUNDATION Fieldbus protocol type. Added the postscript about FOUNDATION Fieldbus protocol type. Corrected from "SPCC" to "SS400" in Housing of size 500 mm to 2600 mm Corrected the value of Pressure on figure. Added the "-F" (FOUNDATION Fieldbus protocol). Added the "-F" (FOUNDATION Fieldbus protocol). Added the postscript about FOUNDATION Fieldbus protocol type.

Edition	Date	Page	Revised Item
8th	Apr. 2007	1-2 1-5 4-3, 4-10 4-4 5-1 5-7 5-7 to 5-8 5-8 5-9 6-1 6-13 6-15 6-16 6-17 6-28 6-29 6-30 6-31 8-8	(4) Changed the warning note of "Maintenance". 1.4 Added the ATEX documentation. 4.3 Added the important note for the wiring ports. (4) Added the important note for a 24 V power supply version (power supply code 2). 2) Corrected the graph of "Supply Voltage and Cable Length". 5 Changed the warning note of "Maintenance". 5.4 Changed the warning note and important note of "Maintenance". 5.4.1 Changed the caution note of "Fuse Replacement". Deleted the Figure 5.4.1. 5.4.2 Changed the content of section "Display Unit Replacement" to "Changing the Direction of the Display Unit". 5.4.3 Deleted the section "Amplifier Replacement". 5.5 Added the important note for "Setting of Switches". Deleted the "Communication Distance" and "Cable length for Specific Applications" from item of "HART". Changed the certificate number of TIIS. Corrected the graph of "Supply Power and Cable Length for Power Supply Code 2". Corrected the value of span flow rate of size 32 mm. Corrected the value of span flow rate of size 1.25 inch and size 36 inch. Added the note to optional codes C1, C2, C3, EM, and G13. Changed the gasket part number of manufacturer for optional code GC. Changed the descriptive text of HF1. Corrected the value of span flow rate of size 32 mm. Added the note to optional codes C1, C2, C3, EM, and G13. 8.5 (1) Changed the certificate number of TIIS.
9th	Jan. 2008	1-1 1-2 4-3 4-6 5-11 6-1 6-7 6-15 6-19 6-21 to 6-32 6-33 to 6-36 6-39 to 6-53	Added the postscript about PROFIBUS PA protocol type. Added the warning note on "write protect". 4.1.4 (2) Added the postscript about PROFIBUS PA protocol type. Added the postscript about PROFIBUS PA protocol type. 5.8.1 Changed the flow chart. Added the postscript about PROFIBUS PA protocol type. Corrected the frequency of "Input Impedance of Communicating Device". Changed the material of housing from "Carbon steel-JIS SPCC" to "Carbon steel-JIS SPCC equivalent". Corrected from "EN1.4404 equivalent" to "EN1.4401 equivalent" in grounding ring of size 1100mm to 2600mm. Added the CAUTION to "EMC Conformity Standard". Changed the note of "Fluid Conductivity". Changed the unit of "Vibration Conditions" from "G" to "m/s ² ". Added the "-G" (PROFIBUS PA protocol). Added the note of process connection code. Added the note of calibration code C. Added the applicable size for the electrode material code W. Added the code F and G to item name. Changed the value of mirror finished ceramics for optional code CM. Added the code G.

Edition	Date	Page	Revised Item
10th	June 2012	<p>1-3</p> <p>2-1</p> <p>3-1</p> <p>3-4</p> <p>3-14</p> <p>3-22</p> <p>4-2</p> <p>4-6</p> <p>4-10</p> <p>5-7</p> <p>6-1</p> <p>6-2</p> <p>6-5</p> <p>6-6 to 6-8</p> <p>6-9</p> <p>6-11</p> <p>6-13</p> <p>6-14</p> <p>6-16</p> <p>6-18 to 6-28</p> <p>6-21, 6-27</p> <p>6-29</p> <p>6-30</p> <p>6-31</p> <p>6-32</p>	<p>Added the "Trademarks".</p> <p>2.2 Deleted the fuse from item of accessories.</p> <p>3.1(3) Added the sentence. Changed ths sentence of *3.</p> <p>3.3 Added the important note. Changed the table 3.3.13.</p> <p>3.1 Added the table 3.3.20 (Sanitary Adapter Identification).</p> <p>4.1.3 Deleted the sentence of JIS C0920 standard. 4.1.3 (2) Corrected the Figure 4.1.1 and added the a washer. Corrected the Figure 4.1.3 and added the a gasket.</p> <p>Corrected the current range of Figure 4.1.12.</p> <p>4.2.3 Deleted the sentence of JIS C0920 standard. Corrected the Figure 4.2.4 and added a washer. Corrected the Figure 4.2.6 and added a gasket.</p> <p>5.4.1 Changed the caution note.</p> <p>6 Added the descriptive text for Converter. Corrected the communication distance and the value of maximum load resistance of BRAIN. Changed the value of minimum load resistance of HART. Deleted the type by JIS C0920 of protection. Changed the kind of coating.</p> <p>Corrected item names of instantaneous flow rate/totalized value display functions. Added the default value of damping time constant.</p> <p>Deleted the type by JIS C0920 of protection. Changed the kind of coating.</p> <p>Changed the housing material in size 2.5 mm to 15 mm from "Stainless steel-JIS SCS11" to "Stainless steel-JIS SCS11 equivalent". Changed the flange material and mini-flange material in size 25 mm to 2600 mm from "Carbon steel-JIS SS400" to "Carbon steel-JIS SS400 or SFVC 2A". Changed the housing material in size 500 to 2600 mm from "Carbon steel-JIS SS400" to "Carbon steel-JIS SS400 equivalent". Changed the material for Adapters (clamp, union, butt weld) of Sanitary Type from "Stainless steel-JIS SUS316L" to "Stainless steel-JIS SUS316L or SUSF316L". Moved the item of Recommended Gaskets Between Flowtubes And User's Flanges from P6-53. Added the Gaskets Size.</p> <p>Abbreviated the HAZARDOUS AREA CLASSIFICATION. Changed the definition of accuracy.</p> <p>Changed the numbers of EMC conformity standards. Changed the note of Fluid Conductivity.</p> <p>Changed the English Units of Measurable Flow Rate Range. Corrected the temperatures of note for General-Purpose Use, Integral Flowmeter.</p> <p>Changed the figures of Ceramics Lining.</p> <p>Deleted the fuse from item of accessories.</p> <p>Changed the standared number on note, from "JIS G 3451" to "JIS G 3443-2". Changed the material for process connection adapters of Sanitary Type from "JIS SUS316L" to "JIS SUS316L or SUSF316L".</p> <p>Changed the applicable model of carbon steel flange.</p> <p>Corrected the current range of /EM. Corrected the sentence of /MU.</p> <p>Added the descriptive text for Special Gaskets.</p> <p>Added the "union joint" to /M01 Changed the selectable range of flow rate span for optional code "SC". Added the "Dual Seal" to Specifications of "CSA Certifications (CF1)". Added notes for Bolts, Nuts, and Gaskets. Added the Singapore and India to applicable sales area of IECEx explosion proof.</p>

Edition	Date	Page	Revised Item
10th	June 2012	6-33 6-34 6-43 6-49 6-53 8-1 8-5 8-8	Corrected the sentence of /MU. Changed the selectable range of flow rate span for optional code "SC". Corrected the figure. Corrected the value of ϕd of CG1. Moved the item of Recommended Gaskets Between Flowtubes And User's Flanges to P6-8. Added the year to applicable standard numbers of CENELEC ATEX. Added the "Process Sealing Certification". Changed the certificate numbers of TIIS Flameproof.
11th	Oct. 2014	1-2 to 1-4 1-5 2-1 3-1 3-3 3-5 3-8 to 3-9 3-11 to 3-13 3-19 4-1 4-2 4-4 4-6 4-8 4-10 4-11 4-11 to 4-14 5-1 5-9 6-1 to 6-47 7-1 8-4 8-4 to 8-5 8-5 8-10 to 8-11	1.1 (1), (3), (4) Added and corrected the warning notes for specification conditions. 1.3 Deleted the description for sizes 500 to 2600mm (20 to 104 inch). 1.4 Corrected the description. 2.1 Deleted the description for sizes 500 to 2600mm (20 to 104 inch). 3.1 (3) Corrected the length of straight run, when installing two or more magnetic flowmeters. 3.2.1 (1) Added the horizontal position figure in Figure 3.2.1. Corrected the vertical position figure in Figure 3.2.1. Corrected the caution notes for transportation. 3.3.1 Corrected the Table 3.3.1. 3.3.2 (4) Corrected the tightening torque values for ceramics lining type in Table 3.3.4 to Table 3.3.6. 3.3.3 (4) Corrected the tightening torque values for ceramics lining type in Table 3.3.7 to Table 3.3.9. 3.3.5 Deleted the description for sizes 500 to 2600mm (20 to 104 inch). Added the PTFE-sheathed nonasbestos gasket in Table 3.3.16. Corrected the inner diameter of grounding ring, outer diameter for effective sealing and recommended inner diameter of gasket in Table 3.3.16. 4.1.1 Corrected the caution notes for wiring ports. 4.1.3 Corrected the important notes. Corrected the Figure 4.1.1. 4.1.4 (3) Changed the numbers of IEC in warning note. 4.1.4 (6) Corrected the value of maximum load resistance in Figure 4.1.10. Corrected the Figure 4.1.12. 4.2.1 Deleted the description for sizes 500 to 2600mm (20 to 104 inch). 4.2.3 Corrected the important notes for wiring ports. Corrected the Figure 4.2.4. 4.2.3 (2) Corrected the Figure 4.2.5. Corrected the Figure 4.2.6. 4.2.4 Deleted the description for sizes 500 to 2600mm (20 to 104 inch). Corrected the Figure 4.2.15. 5.1 Deleted the description for sizes 500 to 2600mm (20 to 104 inch). 5.5.2 Corrected the notes for the write protect switch. 5.8 Added the maintenance of the LCD display. 6 Deleted the description for sizes 500 to 2600mm (20 to 104 inch). Added the values of withstand voltage for optional codes WT1 and WT2. Added the number of EN standard in Safety Requirement Standards. Added the applicable model for optional code K1. Added the optional codes E01, WT1, WT2, PM1, PM2, PM3 and PT. Added the parts number in the table of flameproof packing adapter for TIIS flameproof type. 7 Deleted the description for sizes 500 to 2600mm (20 to 104 inch). 8.2 (2) Added the figure for electrical connection in FM. 8.2 (3), (4), (5) Added the warning notes in FM. 8.3 (1) Changed the number of Applicable Standard in CSA. 8.5 (2) Added the parts number in the table of flameproof packing adapter for TIIS flameproof type. Added the description for wiring ports.

Edition	Date	Page	Revised Item
12th	Jan. 2015	4-6	4.1.4 (6) Corrected the Figure 4.1.12.
		6-30	6 Corrected the note *15 in Table of Optional Specifications.
		8-2	8.1 (2) Corrected the electrical connection marking in ATEX.
		8-4	8.2 (1) Added the note for temperature code in FM.
13th	Sep. 2015	1-1	1. Added the NOTE for this manual.
		1-3	1.1 (7) to (9) Added the WARNING and sentences.
		1-4	1.3 Changed the IMPORTANT for combination remote converters.
		2-1	2.1 Changed the name plate and deleted the note in Figure 2.1.1, Figure 2.1.2.
		4-13	4.2.4 (4) Changed the IMPORTANT for combination remote converters.
		5-6	5.3 Deleted the parts number in Table 5.3.3.
		6-6	6. Added the mini-flange material for sanitary type.
		6-7	Added the grounding ring/grounding electrode material.
		6-8	Changed the sentences for combination remote converters.
		6-9	Changed the note for accuracy. Added the note for maximum power consumption.
			Changed the optional code (from KF2 to KF21, from SF2 to SF21).
		6-10	Changed the CAUTION for withstand voltage. Added applied "EN" standard and the performance specification in EMC Conformity Standards. Deleted the logos.
		6-15 to 6-25	Changed the note for combination remote converters. Added the grounding ring/grounding electrode material.
		6-28	Changed the sentences for optional code M01 and E01.
		6-29	Changed the optional code (from KF2 to KF21, from SF2 to SF21).
		6-30	Changed the note for combination remote converters.
		7-1	7. Changed the table and note for PED.
		8-1	8. Added the NOTE for this manual.
		8-1 to 8-5	8.1 Added and changed the sentences, notes and figure for ATEX certification.
8-8 to 8-12	8.4 Added and changed the sentences, notes and figure for IECEx certification.		

Edition	Date	Page	Revised Item
14th	May 2016	1-3	1.1 (5) Added the sentences for explosion proof type. Deleted the ATEX Documentation.
		3-8 to 3-10	3.3.2 (4) Added the JPI flange rating in Table 3.3.4 to Table 3.3.6.
		3-12 to 3-14	3.3.3 (4) Added the JPI flange rating in Table 3.3.7 to Table 3.3.10.
		3-16 to 3-17	3.3.4 (2) Added the JPI and AS flange ratings in Table 3.3.13 to Table 3.3.15.
		4-1	4.1.1 Corrected the CAUTION for a blanking plug.
		5-10 to 5-12	5.9 Changed the flow chart for troubleshooting.
		6-1	6. Corrected the sentences for HART and Protection.
		6-5	Corrected the sentences for Protection. Added the sentences for Coating.
		6-6 to 6-7	Added the materials for the flange, mini-flange and pipe.
		6-10	Added the sentence for CE marking.
		6-12	Corrected the note for fluid temperature.
		6-15 to 6-25	Added the process connection code AP1, BP1, CS1, CS2, PA1, PA2, PD1, PD2, PD4 and PJ1. Corrected the note for table.
		6-27 to 6-28	Corrected the sentences for the optional code BCC, BCF, BSC, BSF and T01.
		6-28	Added the optional code WPA.
		6-29	Corrected the sentences for the optional code G11.
		6-30	Added the note for the optional code WPA.
		6-35 to 6-39	Added the external dimensions for the process connection code AP1, BP1, CS1, CS2, PA1, PA2, PD1, PD2, PD4 and PJ1.
		6-45	Corrected the flange thickness for size 150mm, ANSI Class 300.
		7-1	7. Corrected the table and notes for PED.
		8-1	8. Added the sentences for explosion proof type.
		8-1	8.1 Deleted the sentences for ATEX explosion proof type. Added the NOTE for ATEX explosion proof type.
		8-4	8.4 Deleted the sentences for IECEx explosion proof type. Added the NOTE for IECEx explosion proof type.