

Thank you for purchasing the JUXTA Signal Conditioner.
Please read through this manual before use for correct handling.

Yokogawa Electric Corporation

2-9-32, Naka-cho Musashino-shi, Tokyo 180-8750 Japan
Phone: +81-422-52-7179 Facsimile: +81-422-52-9802

CAUTIONARY NOTES FOR SAFE USE OF THE PRODUCT

This User's Manual should be carefully read before installing and operating the product. Please keep this User's Manual for future reference.

The following symbol is used on the product and in this manual to ensure safe usage.



This symbol is displayed on the product when it is necessary to refer to the User's Manual for information on personal and instrument safety. This symbol is displayed in the User's Manual to indicate precautions to avoid danger to the operator, such as an electric shock.

The following symbols are used only in this manual.



NOTE

Draws attention to essential information for understanding the operations and/or functions of the product.

CHECKING PRODUCT SPECIFICATIONS AND PACKAGE

(1) Checking the Model and Product Specifications

Check that the model and specifications indicated on the nameplate attached to the main unit are as ordered.

(2) Packaged Items

Check that the package contains the following items:

- WA0A: 1
- Mounting block: 2
- Tag number label and Range label: 1 each
- Mounting screw (M4 x 0.7): 4
- User's Manual (this manual: IM 77J09A10-01EN)

GENERAL

The WA0A is a compact, front terminal connection type isolator that converts 1 to 5 V DC signals into isolated DC current signals.

MODEL AND SUFFIX CODES

Model	Suffix codes	Description
WA0A	-□ □ -□ *C	Output Isolator
Input	6	1 to 5 V DC
Output	A	2 to 10 mA DC
	H	10 to 50 mA DC
	Z	(Custom order) DC current signal
Power supply	-1	24V DC \pm 10%
	-2	100-240 V AC (-15%, +10%) 50/60Hz
Style code	*C	Style C

1. MOUNTING METHOD

1.1 Installing/Uninstalling the Mounting Block

The mounting block is necessary for rack mounting or wall mounting.

Installing the mounting block

- Fit the mounting block into the grooves of the converter, and slide it in the direction of an arrow as shown below-left.

Uninstalling the mounting block

- Lift the stopper using a slotted screw-driver as shown below-right, and pull the mounting block to remove it.

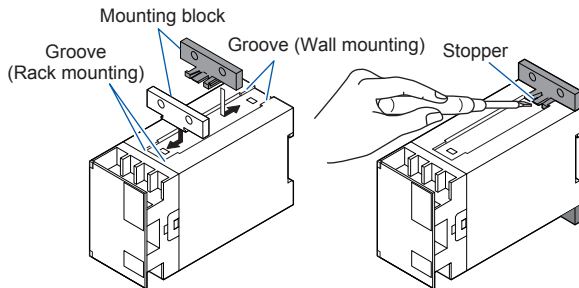

1.2 Rack Mounting

Take the FRK panel and install it on a mounting angle as shown below.

This method is suitable for high density mounting of the converters on a 19-inch rack panel.

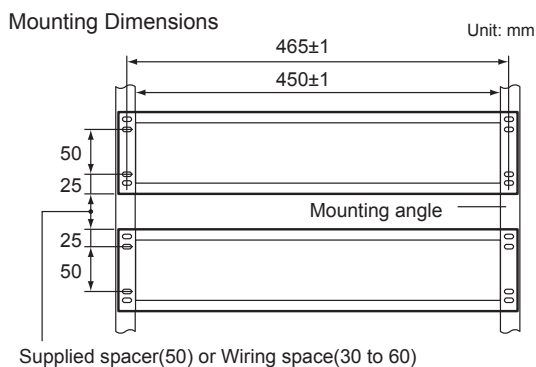
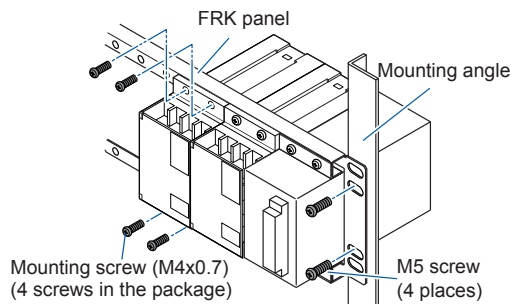

1.3 Wall Mounting

Mount the converter onto the FRK panel as shown below or mount it directly on the wall.

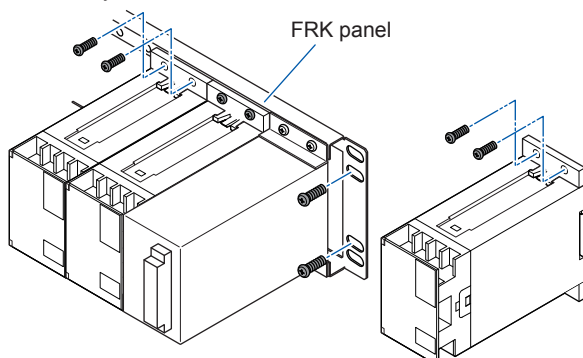

1.4 DIN Rail Mounting

Place the converter so that the DIN rail fits into the upper part of the DIN-rail groove at the rear of the converter, and push until it clicks. The converter is fixed by a slide lock (at the lower part on the rear side of the converter).

To remove the converter, pull down the slide lock using a slotted screw-driver.

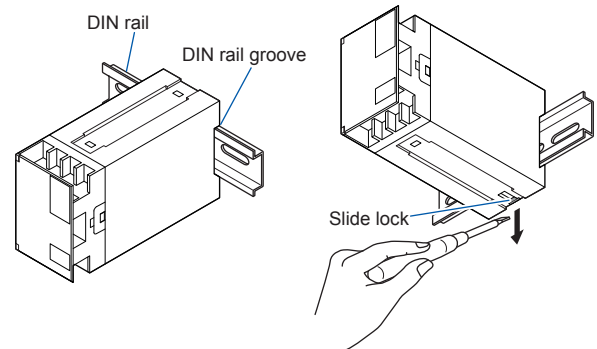

1.5 Mounting Dimensions

Unit: mm

Angle Mounting Dimensions

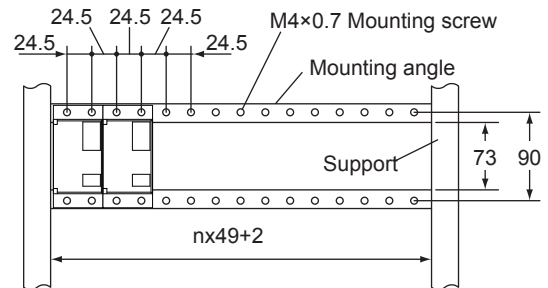

Wall Mounting Dimensions

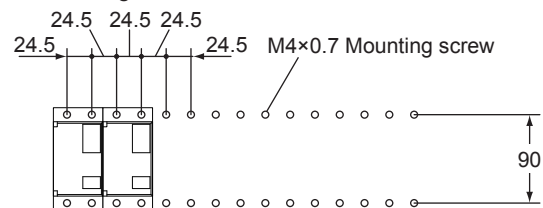

2. INSTALLATION LOCATION

- Avoid the following environments for installation locations: Areas with vibration, corrosive gases, dust, water, oil, solvents, direct sunlight, radiation, a strong electric field, and/or a strong magnetic field, altitude of more than 2000m above sea level.
- If there is any risk of a surge being induced into the power line and/or signal lines due to lightning or other factors, a dedicated lightning arrester should be used as protection for both this converter and a field-installed device.
- Operating temperature/humidity range: 0 to 50°C/5 to 90%RH (no condensation)

3. EXTERNAL WIRING



WARNING

Be sure to turn OFF the power supply before wiring to avoid the risk of electric shock. Use a tester or similar device to ensure that no power is being supplied to a cable to be connected.

M4 screw terminals are provided for the connection of external signals. Attach a crimp-on lug to each wire for connection to the terminals.

- Recommended cables: A nominal cross-sectional area of 0.5 mm² or thicker for signal cables, and that of 1.25 mm² or thicker for power cables.

Wiring Diagram

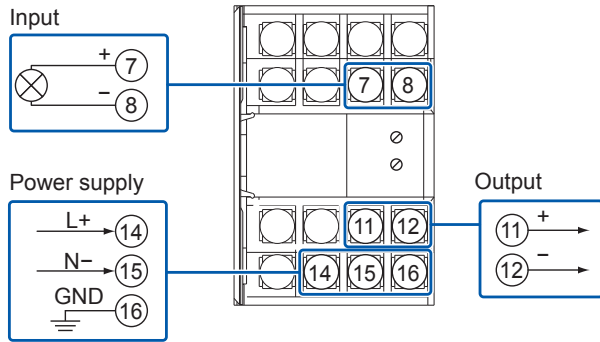

NOTE

- Do not connect anything to the terminals that are not used in the wiring diagram. Otherwise it may cause the malfunction or damage.
- The power line and input/output signal lines should be installed away from noise-generating sources. Otherwise accuracy cannot be guaranteed.
- Make sure to earth ground the ground terminal through minimum resistance. The length and thickness of the grounding cable should be as short and thick as possible. Directly connect the lead from the ground terminal ⑯ of the product to the ground. Do not carry out daisy chained inter-ground terminal wiring.
- The ground terminal ⑯ becomes effective for AC power only.
- Adhere strictly to the specifications to avoid overheating or damage. Before turning on the power, ensure the following:
 - (a) Power supply voltage and input signal value applied to the product should meet the required specifications.
 - (b) The external wiring to the terminals and wiring to ground are as specifications.
- Do not operate the product in the presence of flammable or explosive gases or vapors.
- This product is sensitive to static electricity; exercise care in handling. Before you operate the product, touch a nearby metal part to discharge static electricity.

Power Supply and Isolation

Power supply voltage:

100-240 V AC \sim (-15%, +10%) 50/60 Hz

24 V DC --- ($\pm 10\%$) (percentage ripple: less than 5% p-p)

Current consumption (24 V DC): 85 mA

Power consumption (100V AC): 9 VA

Insulation resistance:

100 M Ω at 500 V DC between input and output, input and power supply, input and ground, output and power supply, output and ground, and power supply and ground.

Withstand voltage:

(DC drive) 1500 V AC/min. between output and (input and power supply). 500 V AC/min. between input and power supply.

(AC drive) 1500 V AC/min. between input and output, input and power supply, input and ground, output and power supply, output and ground, and power supply and ground.

Power supply suffix codes: DC drive [-1], AC drive [-2]

4. MAINTENANCE

The product starts running immediately when the power is turned on; however, it needs 10 to 15 minutes of warm-up before it meets the specified performance.

4.1 Calibration Apparatus

- A voltage current source (Yokogawa 7651 or equivalent)
- A digital multimeter, DMM (Yokogawa 7561 or equivalent)
- A precision resistor of $250\Omega \pm 0.01\%$, 1W

4.2 Calibration Procedure

1. Connect the instruments as shown below.

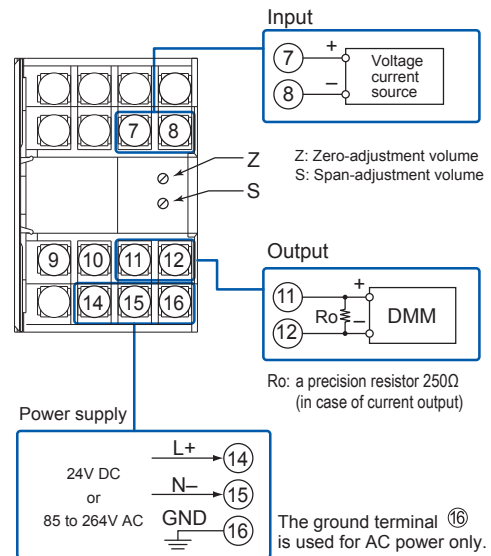

2. Use the voltage current source and apply signals equivalent to 0, 25, 50, 75, and 100% of the measuring range to the isolator.
4. Verify that the corresponding output voltages are 0, 25, 50, 75, and 100% respectively and within the specified accuracy rating. (Ro is used for current output.)
- If the output signals are out of the accuracy rating range, adjust the output signal level using the zero and span adjustment volumes on front face of the product.

