

# InspectorP64x/65x

2D vision

**SICK**  
Sensor Intelligence.



---

### Described product

InspectorP64x Flex

InspectorP65x Flex

InspectorP65x DynamicFocus

### Manufacturer

SICK AG

Erwin-Sick-Str. 1

79183 Waldkirch

Germany

### Legal information

This work is protected by copyright. Any rights derived from the copyright shall be reserved for SICK AG. Reproduction of this document or parts of this document is only permissible within the limits of the legal determination of Copyright Law. Any modification, abridgment or translation of this document is prohibited without the express written permission of SICK AG.

The trademarks stated in this document are the property of their respective owner.

© SICK AG. All rights reserved.

### Original document

This document is an original document of SICK AG.



## Contents

<b>1</b>	<b>About this document.....</b>	<b>5</b>
1.1	Information on the operating instructions.....	5
1.2	Scope.....	5
1.3	Explanation of symbols.....	5
1.4	Further information.....	6
1.5	SICK service.....	6
<b>2</b>	<b>Safety information.....</b>	<b>7</b>
2.1	Intended use.....	7
2.2	Improper use.....	7
2.3	Internet protocol (IP) technology.....	7
2.4	Limitation of liability.....	8
2.5	Modifications and conversions.....	8
2.6	Requirements for skilled persons and operating personnel.....	8
2.7	Operational safety and particular hazards.....	9
2.8	Repairs.....	11
<b>3</b>	<b>Product description.....</b>	<b>12</b>
3.1	Product ID.....	12
3.2	Scope of delivery.....	13
3.3	Product characteristics.....	14
<b>4</b>	<b>Transport and storage.....</b>	<b>17</b>
4.1	Transport.....	17
4.2	Transport inspection.....	17
4.3	Storage.....	17
<b>5</b>	<b>Mounting.....</b>	<b>18</b>
5.1	Overview of mounting procedure.....	18
5.2	Optic kit scope of delivery.....	18
5.3	Preparation for mounting.....	18
5.4	Mount the optics.....	19
5.5	Mounting location.....	21
5.6	Mounting the device.....	26
<b>6</b>	<b>Electrical installation.....</b>	<b>28</b>
6.1	Safety.....	28
6.2	Connections and pin assignment.....	30
6.3	Connection diagrams.....	31
6.4	Connecting the device.....	33
6.5	CDB650-204 wiring connection module.....	36
6.6	CDM420-0006 wiring connection module.....	45
<b>7</b>	<b>Commissioning.....</b>	<b>55</b>
7.1	Installing SensorApps and programming the device.....	55

<b>8</b>	<b>Maintenance.....</b>	<b>57</b>
8.1	Maintenance plan.....	57
8.2	Cleaning.....	57
8.3	Repairs.....	59
<b>9</b>	<b>Troubleshooting.....</b>	<b>60</b>
9.1	Overview of possible errors and faults.....	60
9.2	SICK Support.....	60
9.3	Returns.....	60
<b>10</b>	<b>Decommissioning.....</b>	<b>61</b>
10.1	Disposal.....	61
<b>11</b>	<b>Technical data.....</b>	<b>62</b>
11.1	Optics and Illumination.....	62
11.2	Performance.....	63
11.3	Interfaces.....	64
11.4	Mechanics and electronics.....	64
11.5	Ambient data.....	65
<b>12</b>	<b>Accessories.....</b>	<b>66</b>
<b>13</b>	<b>Annex.....</b>	<b>67</b>
13.1	EU declaration of conformity / Certificates.....	67
13.2	Licenses.....	67

# 1 About this document

## 1.1 Information on the operating instructions

These operating instructions provide important information on how to use devices from SICK AG.

Prerequisites for safe work are:

- Compliance with all safety notes and handling instructions supplied.
- Compliance with local work safety regulations and general safety regulations for device applications

The operating instructions are intended to be used by qualified personnel and electrical specialists.



### NOTE

Read these operating instructions carefully to familiarize yourself with the device and its functions before commencing any work.

The instructions constitute an integral part of the product and are to be stored in the immediate vicinity of the device so they remain accessible to staff at all times. Should the device be passed on to a third party, these operating instructions should be handed over with it.

These operating instructions do not provide information on operating the machine or system in which the device is integrated. For information about this, refer to the operating instructions of the specific machine.

## 1.2 Scope

These operating instructions serve to incorporate the device into a customer system. Instructions are given by stages for all actions required.

These operating instructions apply to all available device variants of the product. More detailed information for identification of the available device type see "Type code", page 12.

Available device variants are listed on the online product page:

- [www.sick.com/InspectorP64x](http://www.sick.com/InspectorP64x)
- [www.sick.com/InspectorP65x](http://www.sick.com/InspectorP65x)

Various device variants are used as examples for commissioning, based on the default parameter settings for the relevant device.

## 1.3 Explanation of symbols

Warnings and important information in this document are labeled with symbols. The warnings are introduced by signal words that indicate the extent of the danger. These warnings must be observed at all times and care must be taken to avoid accidents, personal injury, and material damage.



### DANGER

... indicates a situation of imminent danger, which will lead to a fatality or serious injuries if not prevented.

**WARNING**

... indicates a potentially dangerous situation, which may lead to a fatality or serious injuries if not prevented.

---

**CAUTION**

... indicates a potentially dangerous situation, which may lead to minor/slight injuries if not prevented.

---

**NOTICE**

... indicates a potentially harmful situation, which may lead to material damage if not prevented.

---

**NOTE**

... highlights useful tips and recommendations as well as information for efficient and trouble-free operation.

---

### 1.4 Further information

**NOTE**

Further documentation for the device can be found on the online product page at:

- [www.sick.com/InspectorP64x](http://www.sick.com/InspectorP64x)
- [www.sick.com/InspectorP65x](http://www.sick.com/InspectorP65x)

There, additional information has been provided depending on the product, such as:

- Model-specific online data sheets for device variants, containing technical data, dimensional drawing, and specification diagrams
  - EU declarations of conformity for the product family
  - Dimensional drawings and 3D CAD dimension models in various electronic formats
  - This documentation, in English and German and other languages if applicable
  - Other publications related to the devices described here
  - Publications dealing with accessories
- 

**Documents on request**

Overview of command strings for the device.

### 1.5 SICK service

If you require any technical information, our SICK Service will be happy to help. To find your agency, see the final page of this document.

---

**NOTE**

Before calling, make a note of all type label data such as type code, serial number, etc., to ensure faster processing.

---

## 2 Safety information

### 2.1 Intended use

The InspectorP6xx is a programmable vision sensor for industrial use for tasks which require high-resolution images at long distances. The program for individual use is created by SICK and HDevelop using SICK AppStudio.

The device is programmed on a PC by using the development environment software SICK AppSpace. Depending on the application, a browser-based, graphical user interface (HMI) can be created, which provides opportunities defined by the application developer to influence an application at operator level. The device offers various interfaces for controlling, programming, and operating purposes, which can be activated as necessary via development environments, control systems (programmable logic controllers), or applications. However, configuration, programming, and control requires various technical skills, depending on how the device is connected and used.

The devices are primarily designed for use in industrial and logistics areas, and they meet the requirements for industrial ruggedness, interfaces and data processing. They are not safety components as per the Machinery Directive 2006/42/EC. They are not intended and not permitted to be used in areas with explosive atmospheres, in corrosive environments, or in extreme ambient conditions.

### 2.2 Improper use

Any use outside of the stated areas, in particular use outside of the technical specifications and the requirements for intended use, will be deemed to be incorrect use.

- The device does not constitute a safety component in accordance with the respective applicable safety standards for machines.
- The device must not be used in explosion-hazardous areas, in corrosive environments or under extreme environmental conditions.
- Any use of accessories not specifically approved by SICK AG is at your own risk.



#### **WARNING**

#### **Danger due to improper use!**

Any improper use can result in dangerous situations.

Therefore, observe the following information:

- Device should be used only in accordance with its intended use.
  - All information in these operating instructions must be strictly observed.
- 

### 2.3 Internet protocol (IP) technology



#### **NOTE**

SICK uses standard IP technology in its products. The emphasis is placed on availability of products and services.

SICK always assumes the following prerequisites:

- The customer ensures the integrity and confidentiality of the data and rights affected by its own use of the aforementioned products.
  - In all cases, the customer implements the appropriate security measures, such as network separation, firewalls, virus protection, and patch management.
-

### 2.4 Limitation of liability

Relevant standards and regulations, the latest technological developments, and our many years of knowledge and experience have all been taken into account when compiling the data and information contained in these operating instructions. The manufacturer accepts no liability for damage caused by:

- Non-adherence to the product documentation (e.g., operating instructions)
- Incorrect use
- Use of untrained staff
- Unauthorized conversions
- Technical modifications
- Use of unauthorized spare parts, consumables, and accessories

With special variants, where optional extras have been ordered, or owing to the latest technical changes, the actual scope of delivery may vary from the features and illustrations shown here.

#### 2.4.1 Programmable device

The InspectorP6xx is a programmable device.

Therefore the respective programmer is responsible for his/her programming performance and the resulting working principle of the device.

The liability and warranty of SICK AG is limited to the device specification (hardware functionality and any programming interfaces) according to the agreed conditions.

Therefore, SICK AG is not liable, among other things, for damages that are caused by programming of the customer or third parties.

### 2.5 Modifications and conversions



#### NOTICE

Modifications and conversions to the device may result in unforeseeable dangers.

---

Interrupting or modifying the device or SICK software will invalidate any warranty claims against SICK AG. This applies in particular to opening the housing, even as part of mounting and electrical installation.

### 2.6 Requirements for skilled persons and operating personnel



#### WARNING

**Risk of injury due to insufficient training.**

Improper handling of the device may result in considerable personal injury and material damage.

- All work must only ever be carried out by the stipulated persons.
- 

This product documentation refers to the following qualification requirements for the various activities associated with the device:



- **Instructed personnel** have been briefed by the operator about the tasks assigned to them and about potential dangers arising from improper action.
- **Skilled personnel** have the specialist training, skills, and experience, as well as knowledge of the relevant regulations, to be able to perform tasks delegated to them and to detect and avoid any potential dangers independently.
- **Electricians** have the specialist training, skills, and experience, as well as knowledge of the relevant standards and provisions to be able to carry out work on electrical systems and to detect and avoid any potential dangers independently. In Germany, electricians must meet the specifications of the BGV A3 Work Safety Regulations (e.g. Master Electrician). Other relevant regulations applicable in other countries must be observed.

The following qualifications are required for various activities:

Table 1: Activities and technical requirements

Activities	Qualification
Mounting, maintenance	<ul style="list-style-type: none"> <li>■ Basic practical technical training</li> <li>■ Knowledge of the current safety regulations in the workplace</li> </ul>
Electrical installation, device replacement	<ul style="list-style-type: none"> <li>■ Practical electrical training</li> <li>■ Knowledge of current electrical safety regulations</li> <li>■ Knowledge of the operation and control of the devices in their particular application</li> </ul>
Commissioning, configuration	<ul style="list-style-type: none"> <li>■ Basic knowledge of the Windows™ operating system in use</li> <li>■ Basic knowledge of the design and setup of the described connections and interfaces</li> <li>■ Basic knowledge of data transmission</li> <li>■ Knowledge of the programming of image-processing systems and network components</li> </ul>
Operation of the device for the particular application	<ul style="list-style-type: none"> <li>■ Knowledge of the operation and control of the devices in their particular application</li> <li>■ Knowledge of the software and hardware environment for the particular application</li> </ul>

## 2.7 Operational safety and particular hazards

Please observe the safety notes and the warnings listed here and in other chapters of this product documentation to reduce the possibility of risks to health and avoid dangerous situations.

### LED radiation of the internal illumination unit (variants of the VI55I illumination unit)



#### NOTE

Only the VI55I integrable illumination units from SICK intended for the application can be used as internal illumination units.

#### Risk group 1

- Color of illumination: blue (aperture angle: wide, medium), red or white
- Color of spot: red, green



### CAUTION

#### Warning! Optical radiation: LED risk group 1

The LEDs may pose a danger to the eyes and skin in the event of incorrect use.

- Protect the eyes and skin against radiation.
  - Use suitable eye protection.
  - Use protective measures such as a screen to shield the radiation.
  - Do not open the housing. Opening the housing will not switch off the light source. Opening the housing may increase the level of risk.
  - Comply with the current national regulations on photobiological security of lamps and lamp systems.
- 

Risk group 2

- Color of illumination: blue (aperture angle: narrow)
- 



### CAUTION

#### Warning! Optical radiation: LED risk group 2

The LEDs may pose a danger to the eyes in the event of incorrect use.

- Protect the eyes and skin against radiation.
  - Use suitable eye protection.
  - Never point the light source at people.
  - Use protective measures such as a screen to shield the radiation.
  - Avoid any reflections on people from reflective surfaces. Be particularly careful during mounting and alignment work.
  - Do not open the housing. Opening the housing will not switch off the light source. Opening the housing may increase the level of risk.
  - Comply with the current national regulations on photobiological security of lamps and lamp systems.
- 

If the product is operated in conjunction with external illumination systems, the risks described here may be exceeded. This must be taken into consideration by users on a case-by-case basis.

---



### CAUTION

#### Optical radiation: Laser class 1

The accessible radiation does not pose a danger when viewed directly for up to 100 seconds. It may pose a danger to the eyes and skin in the event of incorrect use.

- Do not open the housing. Opening the housing may increase the level of risk.
  - Current national regulations regarding laser protection must be observed.
- 

Caution – Use of controls or adjustments or performance of procedures other than those specified herein may result in hazardous radiation exposure.

#### For both radiation types:

It is not possible to entirely rule out temporary disorienting optical effects, particularly in conditions of dim lighting. Disorienting optical effects may come in the form of daz-zle, flash blindness, afterimages, photosensitive epilepsy, depending on parameteriza-tion), or impairment of color vision, for example.

**WARNING****Electrical voltage!**

Electrical voltage can cause severe injury or death.

- Work on electrical systems must only be performed by qualified electricians.
- The power supply must be disconnected when attaching and detaching electrical connections.
- The product must only be connected to a voltage supply as set out in the requirements in the operating instructions.
- National and regional regulations must be complied with.
- Safety requirements relating to work on electrical systems must be complied with.

**WARNING****Risk of injury and damage caused by potential equalization currents!**

Improper grounding can lead to dangerous equipotential bonding currents, which may in turn lead to dangerous voltages on metallic surfaces, such as the housing. Electrical voltage can cause severe injury or death.

- Work on electrical systems must only be performed by qualified electricians.
- Follow the notes in the operating instructions.
- Install the grounding for the product and the system in accordance with national and regional regulations.

## 2.8 Repairs

Repair work on the device may only be performed by qualified and authorized personnel from SICK AG. Interruptions or modifications to the device by the customer will invalidate any warranty claims against SICK AG.

### 3 Product description

#### 3.1 Product ID

##### 3.1.1 Type label

The type label gives information for identification of the sensor.

UL certification is dependent on the type. Information on the existing UL certification can be found on the type label.

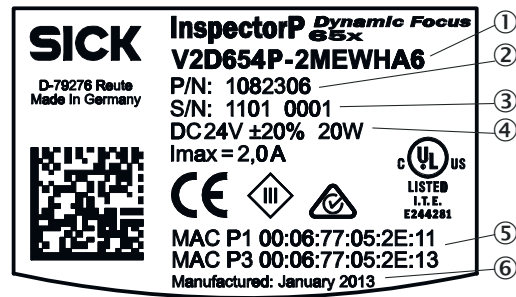

Figure 1: Type label design for the sensor

- ① Type code
- ② Product information number
- ③ Serial number
- ④ Power consumption
- ⑤ MAC addresses
- ⑥ Date of manufacture

##### 3.1.2 Type code

V	2	D	6	x	x	P	-	x	M	x	x	x	x	x
1	2	3	4	5	6	7		8	9	10	11	12	13	14

Position	Description
1 ... 5	<b>Product family</b> V2D6xx InspectorP6xx
6	<b>Image sensor resolution</b> 2: For InspectorP642: 1.7 megapixels (1600 px x 1088 px) 2: For InspectorP652: 2.1 megapixels (2048 px x 1088 px) 4: 4.2 megapixels (2048 px x 2048 px)
7	<b>Function</b> P: Programmable
8	<b>Generation</b>
9	<b>Image sensor type</b> M: Monochrome
10	<b>Lens unit type</b> E: Electrical focus (dynamic, auto, teach-auto) C: C-mount thread
11	<b>Illumination</b> R: Red/Amber W: White B: Blue X: No illumination unit installed

Position	Description
12	<b>Focal distance (lens unit)</b> H: 54 mm K: 40 mm X: No lens installed
13	<b>Connection variants<sup>1)</sup></b> A: Connection variant 1 F: Connection variant 2 H: Connection variant 3
14	<b>IP protection class and front screen</b> 5: IP 65: Plastic front screen 6: IP 65: Glass front screen

<sup>1)</sup> see "Connections and pin assignment", page 30

### 3.2 Scope of delivery

Depending on the device version and the accessories ordered, the scope of delivery will include the listed items:

- The version of the camera housing ordered, with a C-mount threaded connection (InspectorP6xx Flex) **or** InspectorP65x Dynamic Focus (incl. pre-mounted lens)
- Two sliding nuts, M5
- Light inlet and electrical connections fitted with protective caps/plugs.
- SW 2 hexagon key for opening and closing the cover of the micro SD card slot and mounting the integrable illumination unit from the optic kit (InspectorP6xx Flex)
- SICK lens cloth (only with Flex variant)

#### Accessories

Accessories, such as the optic kit, brackets, and connecting cables, are only supplied if ordered separately.

## 3.3 Product characteristics

### 3.3.1 Device view

InspectorP64x/65x Flex dimensional drawing

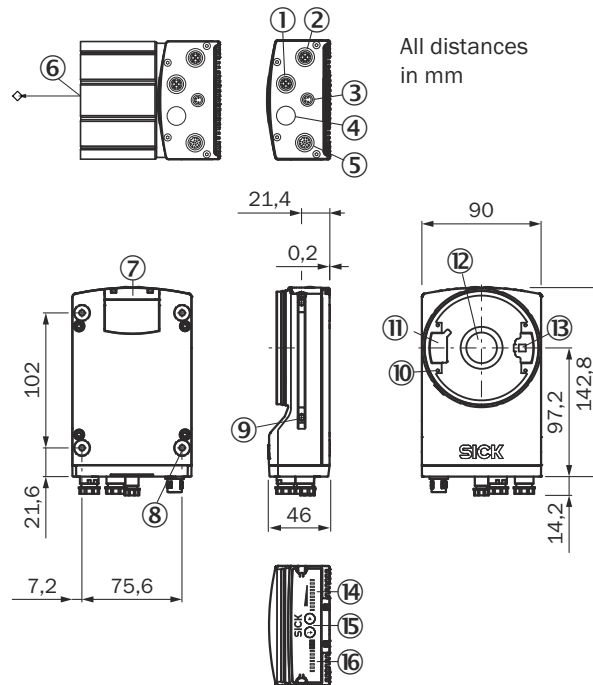

- ① Connection P1, function and design dependent on type
- ② Gigabit Ethernet port
- ③ Connection X2, function and design dependent on type
- ④ Connection P2, function and design dependent on type
- ⑤ Connection X1, function and design dependent on type
- ⑥ Reference point for working distance (center of front screen) from InspectorP64x/65x Flex to object
- ⑦ Black cover for the micro SD memory card slot
- ⑧ M5 blind tapped holes, 5 mm deep (4 x), for mounting the InspectorP64x/65x Flex
- ⑨ Optics protective hood for lens unit and integrated illumination
- ⑩ Sliding nut M5, 5.5 mm deep (2 x), pivoting, for an alternative method of mounting the InspectorP64x/65x Flex
- ⑪ Feedback LED, green
- ⑫ Lens unit
- ⑬ Outlet opening for light beam from aiming laser
- ⑭ Bar graph display (10 x LEDs)
- ⑮ Function button (2 x)
- ⑯ Status display (10 x LEDs)

### Integrable illumination unit (option)

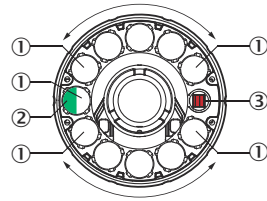

- ① Illumination via 11 LEDs
- ② Feedback LED, green (pass), briefly generates a light spot on the object within the field of view after a successful analysis (default)
- ③ Opening in the illumination for the aiming laser for alignment, the red laser LEDs can be switched off and generates a red cross on the object within the field of view

### 3.3.2 Status indicators and functions



- ① Enter pushbutton
- ② Skip pushbutton

See [table 2](#) for LED descriptions. The functions for the programmable LEDs are defined by the user in the SICK AppStudio software.

Table 2: LED status descriptions

Display	LED	Color	Status
Ready		green	Sensor ready
		red	Hardware or software error
Result	Programmable	red, green, blue, fuchsia, yellow, aqua, white	Function defined by user
Light	Programmable	red, green, blue, fuchsia, yellow, aqua, white	Function defined by user
Function	Programmable	red, green, blue, fuchsia, yellow, aqua, white	Function defined by user
L/A P3 GbE		green	The device is connected to a network
L/A P1 GbE			Not in use
L/A P2 FB			Not in use
L/A P1 FB			Not in use
BF ERR MS			Not in use
SF RUN NS			Not in use
LED bar graph (0 - 9)	Programmable	green	Function for each LED defined by user

= illuminated, = flashing

### 3.3.3 Product features and functionality

The InspectorP6xx is a vision sensor which is well-suited for a wide variety of industrial tasks thanks to its programmable interface.

Convenient functions such as function buttons, auto-setup, aiming laser, an acoustic feedback signal, and a green feedback LED reduce the amount of work required for training and installation.

The microSD memory card can be used to store images or backup copies of parameters. Thanks to SICK's 4Dpro feature, the InspectorP6xx can be integrated into numerous industrial networks.

#### 3.3.4 SICK AppSpace



The SICK AppSpace ecosystem reveals new paths leading to solutions for customer-specific applications and consists of software tools and programmable sensors or devices, such as the InspectorP6xx. The SICK AppStudio SDK is used for developing SensorApps on programmable SICK devices. Its user interface for machine operators can be created individually as a web GUI. The SICK AppManager software tool supports the service in the field in the simple distribution and management of SensorApps.

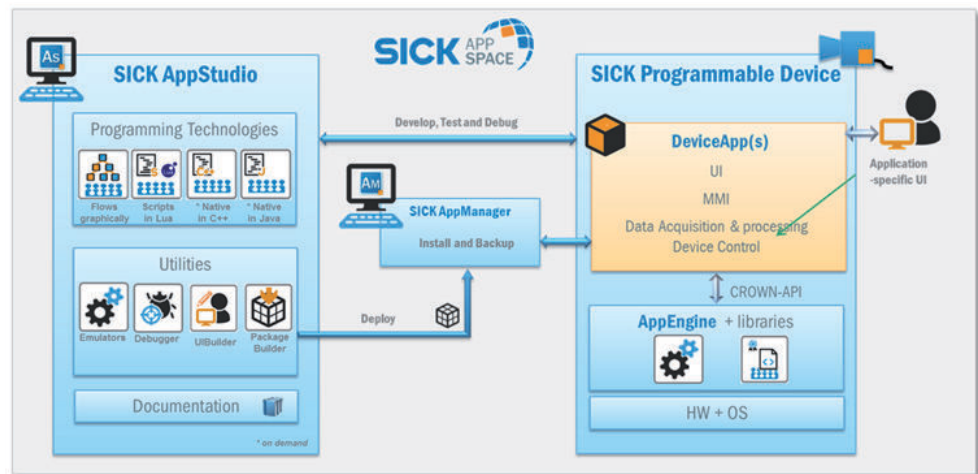

Figure 2: SICK AppSpace

Detailed instructions for SICK AppStudio and for programming the InspectorP6xx can be found in the SICK Support Portal, [supportportal.sick.com](https://supportportal.sick.com).



## 4 Transport and storage

### 4.1 Transport

For your own safety, please read and observe the following notes:



#### NOTICE

##### Damage to the product due to improper transport.

- The device must be packaged for transport with protection against shock and damp.
- Recommendation: Use the original packaging as it provides the best protection.
- Transport should be performed by trained specialist staff only.
- The utmost care and attention is required at all times during unloading and transportation on company premises.
- Note the symbols on the packaging.
- Do not remove packaging until immediately before you start mounting.

### 4.2 Transport inspection

Immediately upon receipt in Goods-in, check the delivery for completeness and for any damage that may have occurred in transit. In the case of transit damage that is visible externally, proceed as follows:

- Do not accept the delivery or only do so conditionally.
- Note the scope of damage on the transport documents or on the transport company's delivery note.
- File a complaint.



#### NOTE

Complaints regarding defects should be filed as soon as these are detected. Damage claims are only valid before the applicable complaint deadlines.

### 4.3 Storage

Store the device under the following conditions:

- Recommendation: Use the original packaging.
- Do not store outdoors.
- Store in a dry area that is protected from dust.
- So that any residual damp can evaporate, do not package in airtight containers.
- Do not expose to any aggressive substances.
- Protect from sunlight.
- Avoid mechanical shocks.
- Storage temperature: [see "Technical data", page 62](#).
- Relative humidity: [see "Technical data", page 62](#).
- For storage periods of longer than 3 months, check the general condition of all components and packaging on a regular basis.

## 5 Mounting

### 5.1 Overview of mounting procedure

The mounting of the device is divided into the following steps:

- Mount the device.
- Align the device with the object.
- Connect the device to interfaces and supply voltage.
- Adjust the device.

### 5.2 Optic kit scope of delivery



Figure 3: Optic kit

The optic kit is an accessory which can be optionally ordered for the InspectorP6xx Flex product family and is mounted on the C-Mount threaded connection of the camera housing.



#### NOTE

The IP protection class IP65 can only be guaranteed with the optic protective hood (can also be ordered individually).

The following components are included in the scope of delivery of the optic kit:

- Application-specific lens unit
- Application-specific V183I illumination unit (ring light), luminous field appropriate for focal distance of lens
- Two spacers, one with a plated-through connection for the electrical connection
- Screws: 4 x M2, 5 x 6 mm, 4 x M2, 5 x 12 mm, all screws have a hexagon cylinder head, SW 2
- IP65 optics protective hood with screw thread and viewing window

### 5.3 Preparation for mounting

#### 5.3.1 Mounting requirements



#### NOTICE

**Radio interference may occur when the device is used in residential areas!**

Only use the device in industrial environments (EN 61000-6-4).

- Ensure that there is good heat transfer from the device, in particular at high ambient temperatures (e.g., via the bracket to the mounting base or ensure that the back of the device is a sufficient distance from the wall of a housing).
- Only to be mounted using the threaded mounting holes provided for this purpose or the sliding nuts.
- Shock and vibration-free mounting.
- Clear view of the object to be measured.

### Equipment required

- Mounting device (bracket) with sufficient load-bearing capacity and suitable dimensions.
- Two or four M5 screws for mounting on a mounting device supplied by the customer. The screw length depends on the mounting base (wall thickness of the bracket). When using an optional SICK bracket, the screws for mounting are included with delivery.
- Tool and tape measure.

### 5.3.2 Mounting the device

The device is mounted using threaded mounting holes (M5) or sliding nuts.

The threaded mounting holes are located on the rear of the device.

The sliding nuts can each be inserted into a slot on the side of the housing.

SICK offers prefabricated brackets which are optimally suited for mounting the device in a wide range of applications ([www.sick.com](http://www.sick.com)).

### User-supplied brackets

A user-supplied bracket must meet the following requirements:

- Alignment of the device in the x and y axes can be adjusted
- The mounting device must be able to bear the weight of the device and connecting cables free of vibrations
- In mounting situations with strong vibrations, shock mounts may need to be provided
- Mounting options must be available for the 4 threaded mounting holes or the two sliding nuts

## 5.4 Mount the optics



### NOTE

This mounting step is only required if the optional optics accessory has been included in the order for a programmable vision sensor of the InspectorP6xx Flex product family. This does not apply for the Dynamic Focus type.

### 5.4.1 Mounting the lens and illumination



### NOTICE

#### Possible impairment of image quality!

Dust and fingerprints on optical boundary surfaces can reduce image quality and may also affect the analysis performance of the device.

- When mounting the optics accessories, always ensure that the environment is free of dust.
- Do not touch the image sensor (CMOS) in the light inlet opening of the sensor or the glass lenses at either end of the lens unit.



### NOTE

When mounting the optics accessories on the camera housing, always ensure that there is no power to the system.

**NOTICE****Risk of damage due to electrostatic discharge!**

Electrostatic discharge from the human body may damage parts of the illumination unit or the camera housing.

The illumination variants for lenses with a focal length of 12 mm or 16 mm do not feature any plastic lenses in front of the LEDs in the round recesses.

- Do not insert your fingers into the recesses.
- Do not touch the open contacts of the electrical connection for the illumination unit on the camera housing.

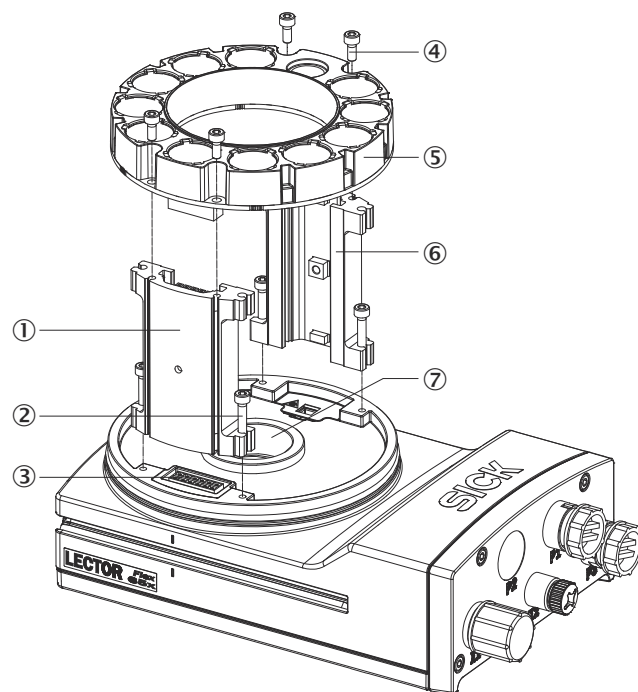
**Mounting the optics**

- ① Spacer, left with electrical connection
- ② Screw, long (4 x)
- ③ Electrical connection for ring light
- ④ Screw, short (4 x)
- ⑤ Ring light
- ⑥ Spacer, right
- ⑦ Light inlet with threaded connection for lens

1. Peel off the white protective sticker on the camera housing that covers the electrical connection ③ for the illumination unit.
2. Place the camera housing on a nonslip base.
3. Remove the protective cap from the round light inlet.
4. If necessary, carefully insert the filter (optional) and spacer disk into the light inlet.
5. Screw the lens unit into the C-mount thread. This will also lock the optional filter in place at the same time (if applicable).
6. Take two pairs of long screws and screw them into the threaded mounting holes to attach each spacer (① and ⑥) to the correct side of the camera housing.
7. Use the 4 short screws to attach the illumination unit ⑤ to the two spacers.
8. Manually preset the sharpness and mask of the lens unit.

**NOTE**

If the required adjustments are not carried out immediately, mount the optics protective hood.

## 5.4.2 Attaching the warning label

Devices and illuminations (VI83) with LEDs in risk group RG 2 feature the following warning label.

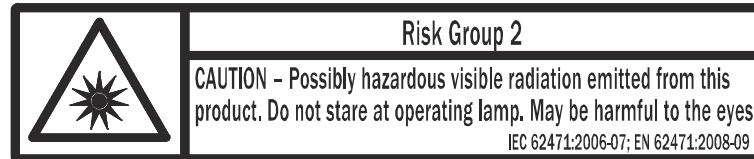

The warning label is located on the exterior of the housing of the devices. For the illumination units, the warning label is located on the outer ring.

Integrable illumination unit types in risk group RG 2 that are to be mounted by the user are accompanied by an additional black and yellow warning label for RG 2 optical radiation.

Attach the additional warning label to the outside of the protective optics cover in a clearly visible location. When the protective optics cover is mounted, the warning label on the illumination unit is hidden.

1. Affix the illumination unit to the device housing.
2. Manually adjust the sharpness and mask settings of the lens unit and check using the live image in SICK AppStudio.
3. Attach the protective optics cover and screw it tight.
4. Attach the warning label to the protective optics cover near the light outlet so that it is clearly visible.
5. If the device itself is integrated into machinery, for example, in a way which obscures the warning label attached, additional, clearly visible labels should be attached to the machinery close to where the light is emitted.

For commissioning using SICK AppStudio see ["Installing SensorApps and programming the device"](#), page 55.

## 5.5 Mounting location

### 5.5.1 Working distance

The field of view is produced depending on the focus position, focal distance of the lens, and the working distance. The necessary working distance can be determined based on the field of view diagram (see ["Field of view diagrams"](#), page 22).

### 5.5.2 Mounting bracket and reflection prevention

In order to avoid reflections from the surfaces to be scanned, the device is tilted so it is perpendicular to the surface.

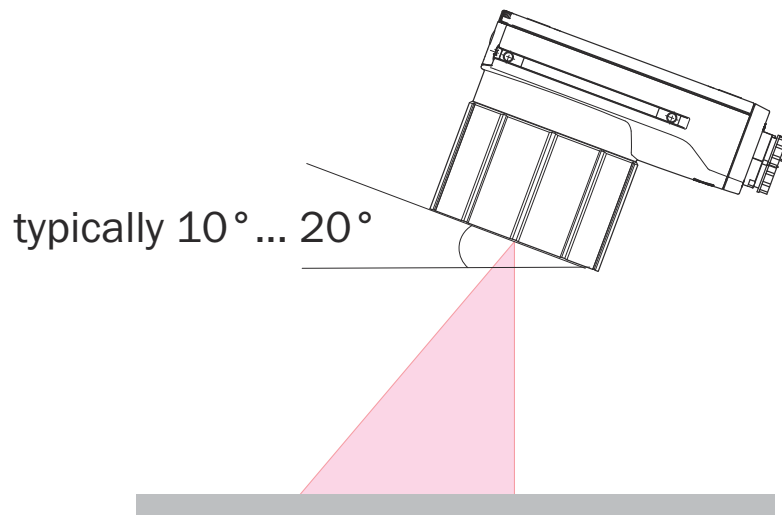

Typical values are between 10° and 20°.

Depending on the application, an angle of between 0° (bright field light) and 45° (dark field light) may be advisable.

### 5.5.3 Field of view diagrams

#### InspectorP64x Flex

Field of view in mm<sup>2</sup>

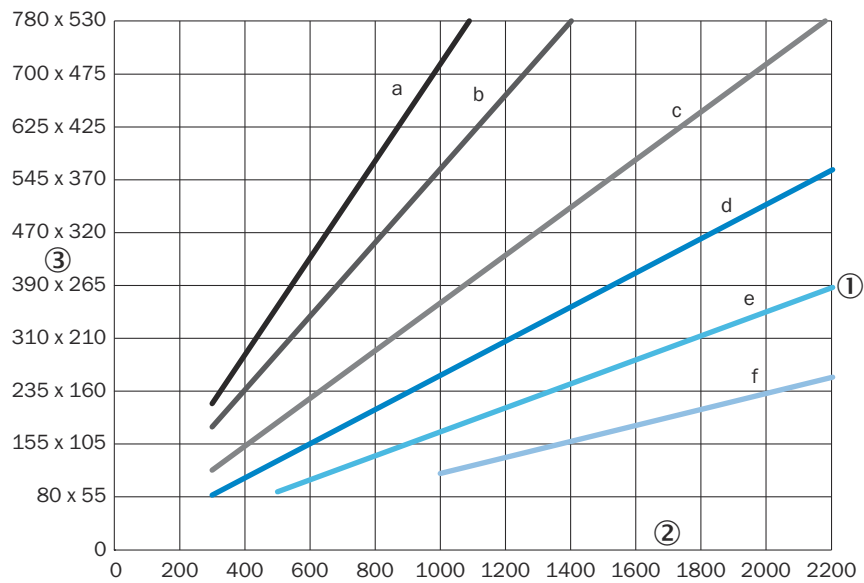

- a: f = 12 mm
- b: f = 16 mm
- c: f = 25 mm
- d: f = 35 mm
- e: f = 50 mm
- f: f = 75 mm

- ① Lens focal length
- ② Working distance in mm
- ③ Field of view in mm<sup>2</sup>

### InspectorP652 Dynamic Focus

Field of view in mm<sup>2</sup>

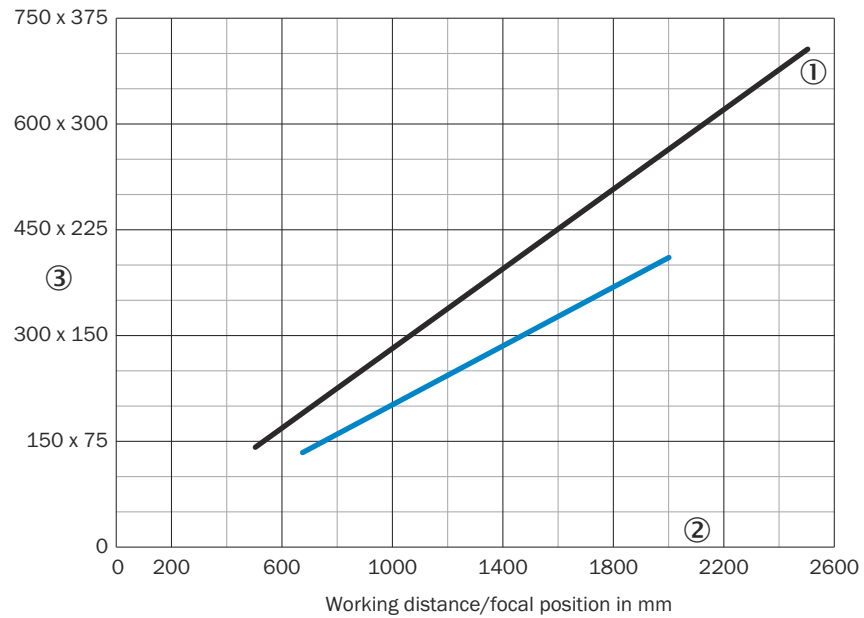

— f = 40 mm (V2D65xR-xxKxx)

— f = 54 mm (V2D652R-xxHxx)

- ① Lens focal length
- ② Working distance in mm
- ③ Field of view in mm<sup>2</sup>

**InspectorP652 Flex**

Field of view in mm<sup>2</sup>

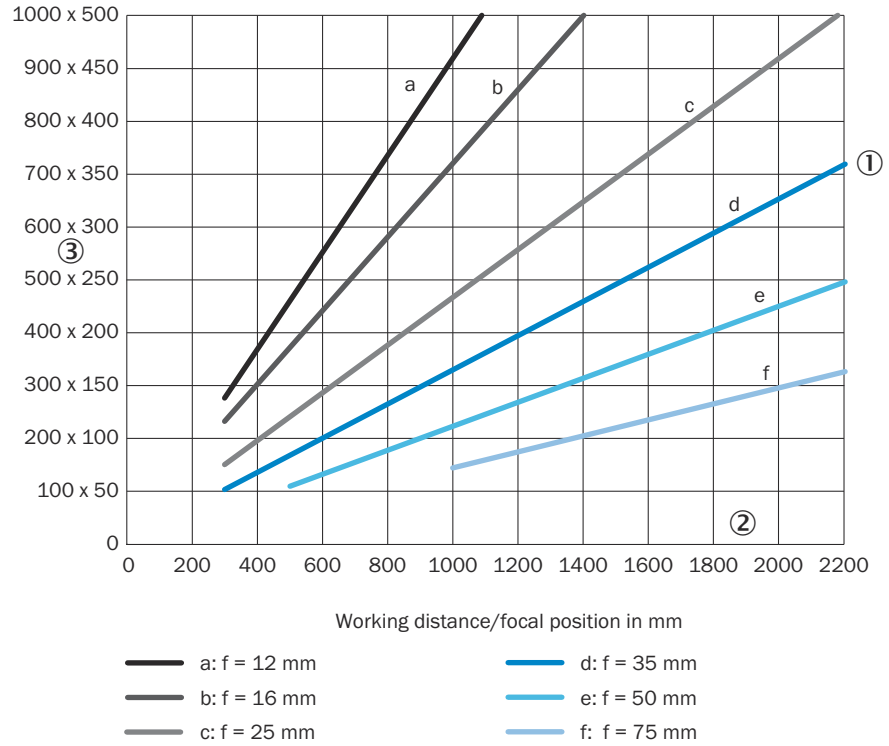

- ① Lens focal length
- ② Working distance in mm
- ③ Field of view in mm<sup>2</sup>



## InspectorP654 Dynamic Focus

Field of view in mm<sup>2</sup>

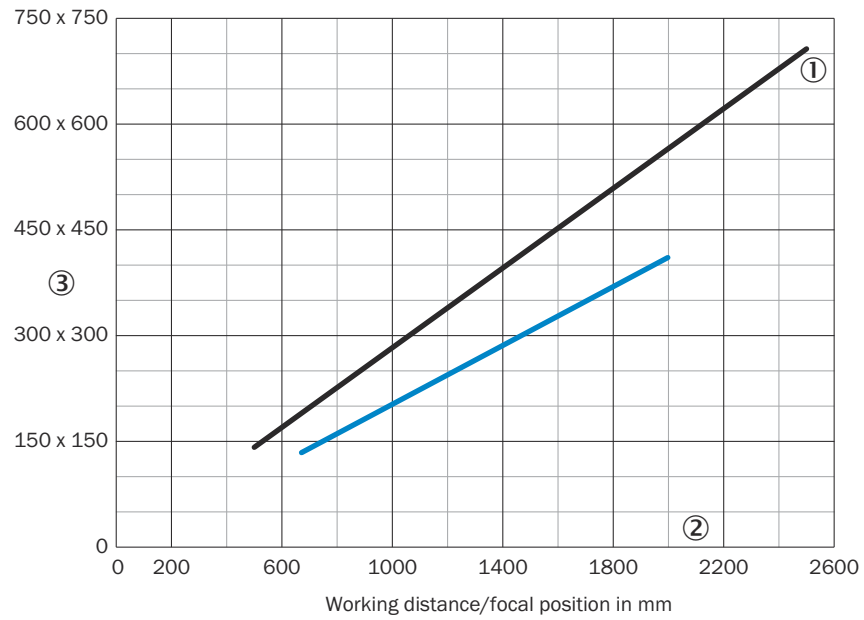

— f = 40 mm (V2D65xR-xxKxx)

— f = 54 mm (V2D654R-xxHxx)

- ① Lens focal length
- ② Working distance in mm
- ③ Field of view in mm<sup>2</sup>

### InspectorP654 Flex

Field of view in mm<sup>2</sup>

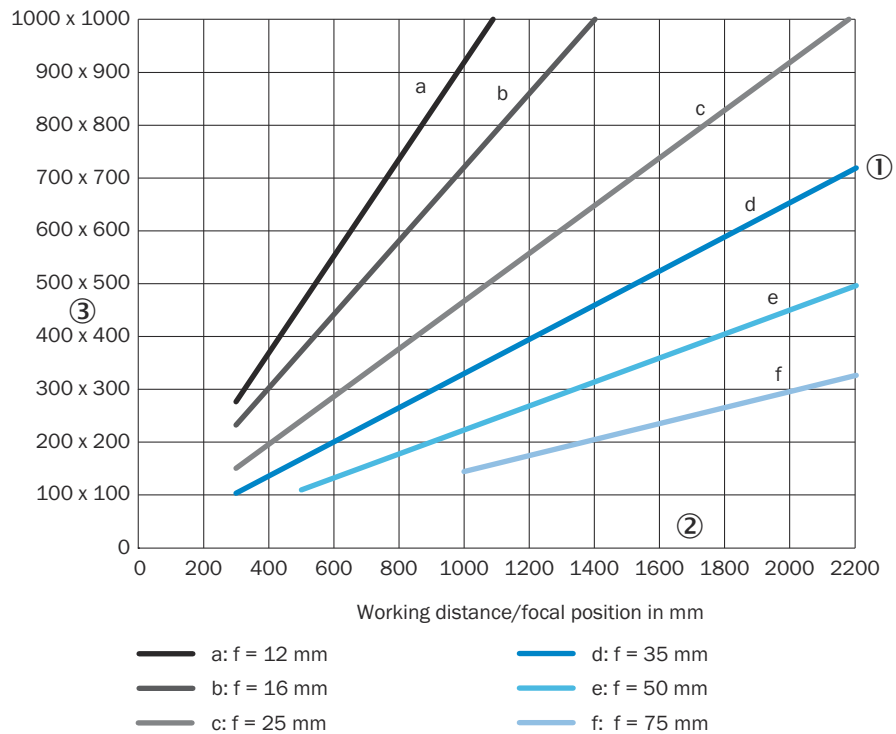

- ① Lens focal length
- ② Working distance in mm
- ③ Field of view in mm<sup>2</sup>

## 5.6 Mounting the device

### Aligning the device plus inspection window with the object

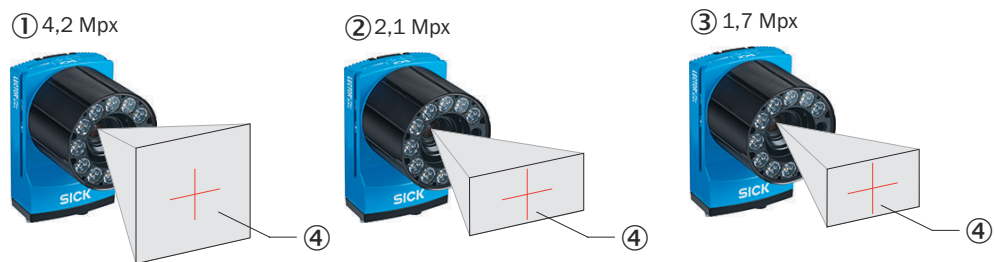

Figure 4: Resolution-dependent reading field geometries

- ① InspectorP654 with 4.2 mpx image sensor
- ② InspectorP652 with 2.1 mpx image sensor
- ③ InspectorP642 with 1.7 mpx image sensor
- ④ Field of view

The device must be aligned in consideration of the field of view (see "Field of view diagrams", page 22) and the application circumstances (see "Mounting requirements", page 18).

### Mounting the device

Perform one of the following steps:

- Mount the device on a bracket supplied by the customer using M5 screws. Screw the screws no more than 5 mm into the tapped blind holes or sliding nuts.
  - To do this, either use all 4 threaded mounting holes on the rear of the device or, alternatively, use the two M5 sliding nuts in the lateral slots.
- Attach the optional SICK bracket that has been ordered separately (e.g. mounting angle, part number 2042902) to the device using the two sliding nuts.

### 6 Electrical installation

#### 6.1 Safety

##### 6.1.1 Notes on electrical installation

---



#### NOTICE

##### Device damage due to improper supply voltage!

All circuits connected to the device must comply with the following requirements:

- SELV (EN 60950-1) or ES1 (EN 62368-1)
  - LPS (EN 60950-1 or EN 62368-1)
- 



#### NOTICE

##### Equipment damage or unpredictable operation due to working with live parts.

Working with live parts may result in unpredictable operation.

- Only carry out wiring work when the power is off.
  - Only connect and disconnect electrical connections when the power is off.
- 

- **The electrical installation must only be performed by electrically qualified personnel.**
  - **Standard safety requirements must be observed when working on electrical systems!**
  - Only switch on the supply voltage for the device when the connection tasks have been completed and the wiring has been thoroughly checked.
  - When using extension cables with open ends, ensure that bare wire ends do not come into contact with each other (risk of short-circuit when supply voltage is switched on!). Wires must be appropriately insulated from each other.
  - Wire cross-sections in the supply cable from the user's power system must be designed in accordance with the applicable standards. When this is being done in Germany, observe the following standards: DIN VDE 0100 (Part 430) and DIN VDE 0298 (Part 4) and/or DIN VDE 0891 (Part 1).
  - Circuits connected to the device must be designed as SELV circuits (SELV = Safety Extra Low Voltage).
  - Protect the device with a separate fuse at the start of the supply circuit.
- 



#### NOTE

##### Layout of data cables

- Use screened data cables with twisted-pair wires.
  - Implement the screening design correctly and completely.
  - To avoid interference, e.g. from switching power supplies, motors, clocked drives, and contactors, always use cables and layouts that are suitable for EMC.
  - Do not lay cables over long distances in parallel with power supply cables and motor cables in cable channels.
- 

##### IP 67 enclosure rating

The IP 67 enclosure rating for the device is only achieved under the following conditions:

- The cables plugged into the M12 and M8 connections are screwed tight.
- Any unused M12 electrical connections must be fitted with screw-on protective caps (for male connectors) or plugs (for female connectors) as the device is supplied.
- The blue cover at the top of the device (function keys) are flush with the device and the fixing screws are tightened.

If this is not done, the device does not fulfill any specified IP enclosure rating!

### 6.1.2 Wiring notes



#### NOTE

Preassembled cables can be found online at:

- [www.sick.com/InspectorP64x](http://www.sick.com/InspectorP64x)
- [www.sick.com/InspectorP65x](http://www.sick.com/InspectorP65x)



#### NOTICE

##### Faults during operation and device or system defects!

Incorrect wiring may result in operational faults and defects.

- Follow the wiring notes precisely.

### 6.1.3 Prerequisites for safe operation of the device



#### WARNING

##### Risk of injury and damage caused by electrical current!

As a result of equipotential bonding currents between the device and other grounded devices in the system, faulty grounding of the device can give rise to the following dangers and faults:

- Dangerous voltages are applied to the metal housings.
- Devices will behave incorrectly or be destroyed.
- Cable shielding will be damaged by overheating and cause cable fires.

#### Remedial measures

- Only skilled electricians should be permitted to carry out work on the electrical system.
- If the cable insulation is damaged, disconnect the voltage supply immediately and have the damage repaired.
- Ensure that the ground potential is the same at all grounding points.
- Where local conditions do not meet the requirements for a safe earthing method, take appropriate measures (e.g., ensuring low-impedance and current-carrying equipotential bonding).

The device is connected to the peripheral devices (voltage supply, any local trigger sensor(s), system controller) via shielded cables. The cable shield – for the data cable, for example – rests against the metal housing of the device. The device can be grounded through the cable shield or through a blind tapped hole in the housing, for example.

If the peripheral devices have metal housings and the cable shields are also in contact with their housings, it is assumed that all devices involved in the installation have the **same ground potential**.

This is achieved by complying with the following conditions:

- Mounting the devices on conductive metal surfaces
- Correctly grounding the devices and metal surfaces in the system
- If necessary: low-impedance and current-carrying equipotential bonding between areas with different ground potentials

If these conditions are not fulfilled, equipotential bonding currents can flow along the cable shielding between the devices due to differing ground potentials and cause the hazards specified. This is, for example, possible in cases where there are devices within a widely distributed system covering several buildings.

**Remedial measures**

The most common solution to prevent equipotential bonding currents on cable shields is to ensure low-impedance and current-carrying equipotential bonding. If this equipotential bonding is not possible, the following solution approaches serve as a suggestion.



**NOTICE**

We expressly advise against opening up the cable shields. This would mean that the EMC limit values can no longer be complied with and that the safe operation of the device data interfaces can no longer be guaranteed.

**Measures for widely distributed system installations**

On widely distributed system installations with correspondingly large potential differences, the setting up of local islands and connecting them using commercially available **electro-optical signal isolators** is recommended. This measure achieves a high degree of resistance to electromagnetic interference.

The use of electro-optical signal isolators between the islands isolates the ground loop. Within the islands, a stable equipotential bonding prevents equalizing currents on the cable shields.

**Measures for small system installations**

For smaller installations with only slight potential differences, insulated mounting of the device and peripheral devices may be an adequate solution.

Even in the event of large differences in the ground potential, ground loops are effectively prevented. As a result, equalizing currents can no longer flow via the cable shields and metal housing.



**NOTICE**

The voltage supply for the device and the connected peripheral devices must also guarantee the required level of insulation.

Under certain circumstances, a tangible potential can develop between the insulated metal housings and the local ground potential.

**6.2 Connections and pin assignment**

Pin	Power/ SerialData/CAN/IO	CAN IN	CAN OUT	USB	Triggering of external illumination	GB Ethernet	Ethernet
	<p>17-pin M12 male connector, A-coded</p>	<p>5-pin M12 male connector, A-coded</p>	<p>5-pin M12 female connector, A-coded</p>	<p>4-pin M8 female connector</p>	<p>3-pin M8 female connector</p>	<p>8-pin M12 female connector, X-coded</p>	<p>4-pin M12 female connector, D-coded</p>

Pin	Power/ SerialData/CAN/IO	CAN IN	CAN OUT	USB	Triggering of external illumination	GB Ethernet	Ethernet
1	GND	Shield	Shield	+5 V	Sensor 1	TRD0_P	TX+
2	DC 24 V ± 20%	DC 24 V ± 20%	DC 24 V ± 20%	Data-	-	TRD0_N	RX+
3	CAN L	GND	GND	Data+	Result 4	TRD1_P	TX-
4	CAN H	CAN H	CAN H	GND	SensGND	TRD1_N	RX-
5	TD+ (RS-422), Host	CAN L	CAN L	-	-	TRD3_P	-
6	TD- (RS-422), Host TxD (RS-232), Host	-	-	-	-	TRD3_N	-
7	TxD (RS-232), AUX	-	-	-	-	TRD2_P	-
8	RxD (RS-232), AUX	-	-	-	-	TRD2_N	-
9	SensGND	-	-	-	-	-	-
10	Sensor 1, switching input	-	-	-	-	-	-
11	RD+ (RS-422), host	-	-	-	-	-	-
12	RD- (RS-422), host RxD (RS-232), host	-	-	-	-	-	-
13	Result 1, switching output	-	-	-	-	-	-
14	Result 2, switching output	-	-	-	-	-	-
15	Sensor 2, switching input	-	-	-	-	-	-
16	Result 3, switching output	-	-	-	-	-	-
17	Result 4, switching output	-	-	-	-	-	-

## 6.3 Connection diagrams

### Connection principle

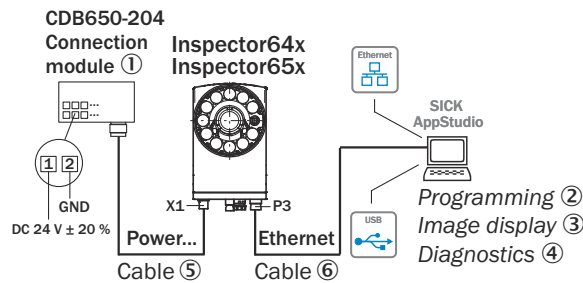

Figure 5: General connection principle

- ① CDB650-204 connection module
- ② Programming
- ③ Image display
- ④ Diagnostics
- ⑤ Cable, e.g. part no. 6051194 (3 m)
- ⑥ Cable, e.g. part no. 6049728 (2 m)

### Wiring without SICK connection module

When using customer-specific connection units, the wiring principle for the signals can be found in the connection diagrams for the connection module CDM420-0006, see ["Connecting the InspectorP6xx to the CDM420-0006"](#), page 33.

6.3.1 Connecting the InspectorP6xx to the CDB650-204

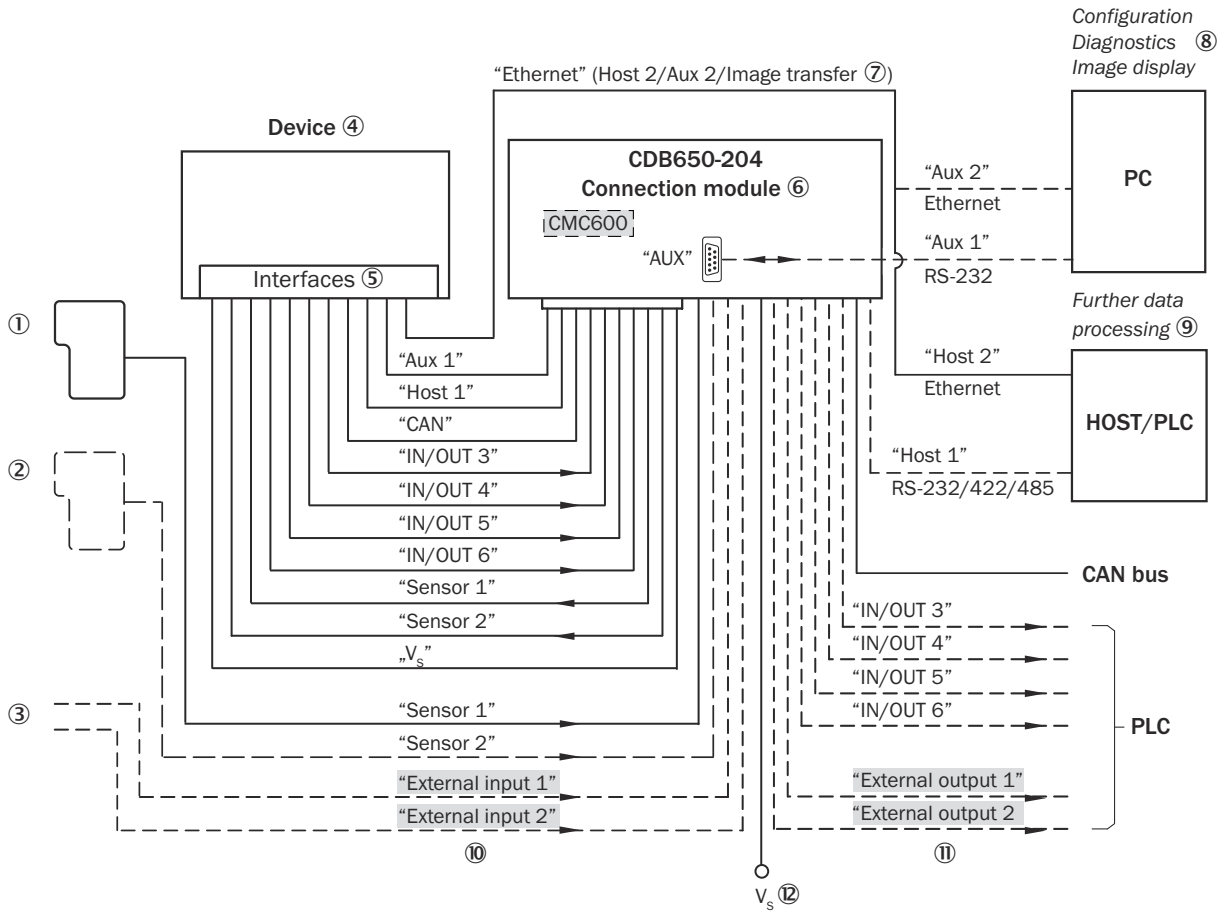

Figure 6: Connection of the device to peripherals via CDB650-204

- ① Start/Stop trigger (e.g. photoelectric sensor)
- ② Application-dependent alternative stop trigger (e.g. photoelectric sensor) or travel increment (incremental encoder)
- ③ Other functions
- ④ Device
- ⑤ Interfaces
- ⑥ Connection module
- ⑦ Image transmission
- ⑧ Configuration, diagnostics and image display
- ⑨ Further data processing
- ⑩ External switching inputs (not supported)
- ⑪ External switching outputs (not supported)
- ⑫ Supply voltage  $V_s = U_V$



### 6.3.2 Connecting the InspectorP6xx to the CDM420-0006

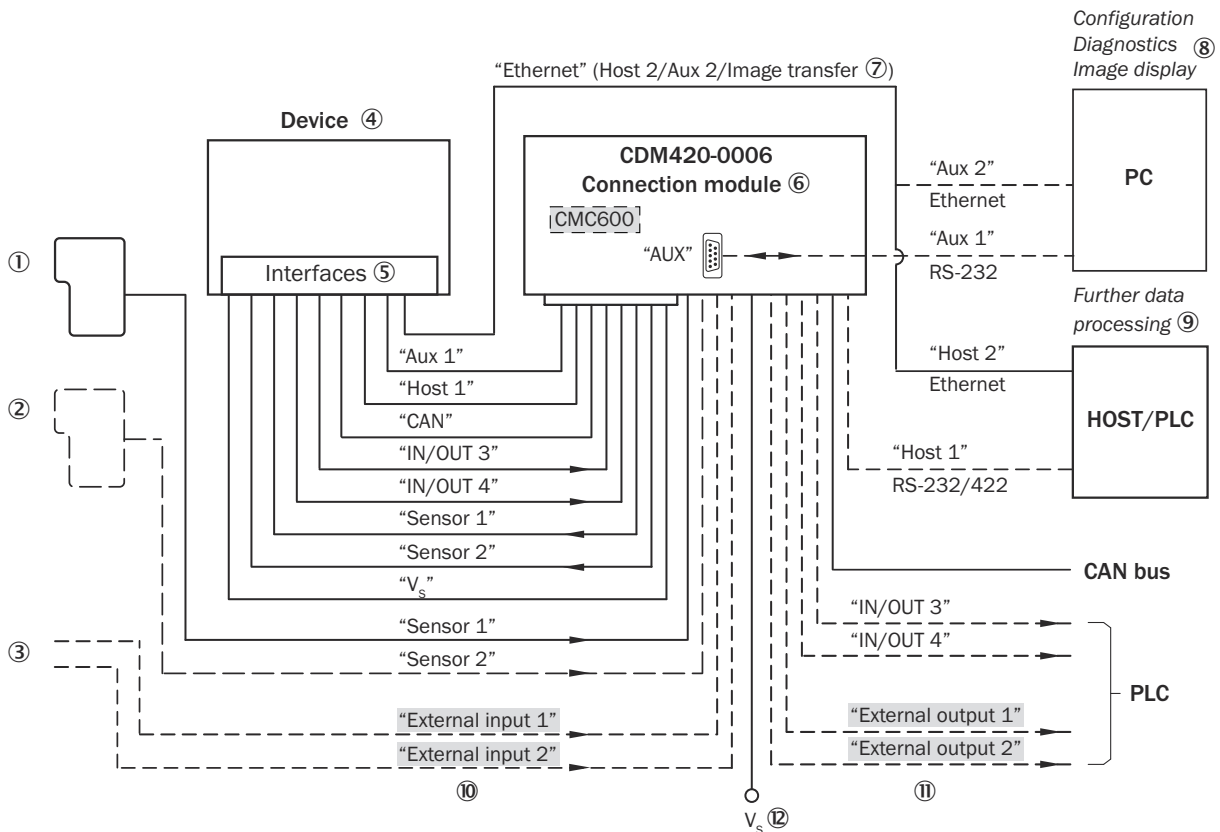

Figure 7: Connection of the device to peripherals via CDM420-0006 (overview)

- ① Start/Stop trigger (e.g. photoelectric sensor)
- ② Application-dependent alternative stop trigger (e.g. photoelectric sensor) or travel increment (incremental encoder)
- ③ Other functions
- ④ Device
- ⑤ Interfaces
- ⑥ Connection module
- ⑦ Image transmission
- ⑧ Configuration, diagnostics and image display
- ⑨ Further data processing
- ⑩ External switching inputs (not supported)
- ⑪ External switching outputs (not supported)
- ⑫ Supply voltage  $V_s = U_v$

## 6.4 Connecting the device

### 6.4.1 Connecting the supply voltage

The device must be connected to a power supply unit with the following properties:

- Supply voltage DC 24 V  $\pm$  20% (stabilized safety extra low voltage SELV (EN 60950-1) or ES-1 (EN 62368-1) LPS (EN 60950-1 or EN 62368-1)
- Voltage source with at least 30 W output power
- Additional 0.5 W output power required when using the optional CMC600 parameter memory module in the CDB650-204 or CDM420-0006 connection module

**Protecting the supply cables**

To ensure protection against short-circuits/overload in the customer’s supply cables, the conductor cross sections used must be appropriately selected and protected.

The following standards must be observed in Germany:

- DIN VDE 0100 (part 430)
- DIN VDE 0298 (part 4) and/or DIN VDE 0891 (part 1)

The infeed of the supply voltage is carried out using the connection module; for more on this, see:

Connection module	Interface	Reference
CDB650-204	Supply voltage	<a href="#">page 38</a>
CDM420-0006	Supply voltage	<a href="#">page 47</a>

The connection module CDB650-204 has a 3 A fuse (slow-blow), the CDM420-0006 has a 2 A fuse (slow-blow) in the circuit after switch S1.

**6.4.2 Wiring the data interface**

**Wiring the Ethernet interface**

1. Connect the sensor to the Ethernet connection of the PC via the adapter cable.
2. Set up communication via SICK AppStudio.



**NOTE**

The Ethernet interface of the device has an Auto-MDIX function. This automatically adjusts the transmission speed as well as any necessary crossover connections.

**Wiring the serial data interfaces**

The maximum data transmission rate for the serial interface depends on the cable length and on the type of interface. The following recommendations apply:

Interface type	Data transmission rate	Distance to the target computer (host)
RS-232	Up to 19.2 kBd 38.4 kBd ... 57.6 kBd 115.2 kBd ... 500 kBd	Max. 10 m Max. 3 m Max. 2 m
RS-422 <sup>1)</sup>	Up to 38.4 kBd 38.4 kBd ... 57.6 kBd 57.6 kBd ... 500 kBd	Max. 1200 m Max. 500 m Max. 10 m

<sup>1)</sup> For RS-422-suitable cable and corresponding cable termination as per specification



**NOTICE**

**Risk of damage to the internal interface modules!**

If the serial data interfaces are wired incorrectly, then electronic components in the device could get damaged.

- Observe the information on wiring.
- Carefully check the wiring prior to switching on the device.

If the wiring is carried out via a connection module:

Connection module	Data interface	Reference
CDB650-204	RS-232	<a href="#">page 39</a>
	RS-422	<a href="#">page 39</a>
CDM420-0006	RS-232	<a href="#">page 48</a>
	RS-422	<a href="#">page 48</a>

#### Termination of the RS-422 data interface

Termination can be implemented in the CDB650-204/CDM420-0006 connection module via switches.

Additional information on this can be found in the operating instructions for the relevant module.

### 6.4.3 Wiring the CAN interface

If the wiring of the CAN interface is carried out via a connection module:

Connection module	Data interface	Reference
CDB650-204	CAN	<a href="#">page 41</a>
CDM420-0006	CAN	<a href="#">page 50</a>

### 6.4.4 Wiring digital switching inputs

#### Physical switching inputs on the device

The two physical switching inputs “Sensor 1” and “Sensor 2” as well as IN/OUT 3 ... 6 can be used for starting and/or ending the trigger or for feeding an incremental signal.

The switching inputs “Sensor 1” and “Sensor 2” as well as IN/OUT 3 ... 6 are available with the adapter cable (17-pin M12 female connector/15-pin D-Sub HD male connector) in combination with the CDM420.

When using the M12 adapter cable (17-pin M12 female connector/17-pin M12 male connector) in combination with the CDB650 or when using the cable with one open end (17-pin M12 female connector/open end), the switching inputs “Sensor 1” and “Sensor 2” and IN/OUT 3 ... 6 are available.



#### NOTE

These two external switching inputs are not suitable for time-critical applications.

If the wiring of the inputs is carried out via a connection module:

CDB650-204	Sensor 1 and Sensor 2	<a href="#">page 42</a>
	Configurable switching inputs IN 3 ... 6	<a href="#">page 45</a>
CDM420-0006	Sensor 1 and Sensor 2	<a href="#">page 51</a>
	Configurable switching inputs IN 3 and 4	<a href="#">page 45</a>

### 6.4.5 Digital IN/OUT

#### Physical switching outputs on the device

The four physical switching outputs “IN/OUT 3 ... 6” can be allocated independently of each other with various functions for the output of the result status. If the allocated event occurs in the analysis process, then the corresponding switching output is live after the end of the trigger for the selected pulse duration.

Switching outputs IN/OUT 3 ... 4 are available at the adapter cable (17-pin, M12 female connector/15-pin D-Sub HD male connector) in combination with the CDM420.

When using the M12 adapter cables (17-pin, M12 female connector/17-pin M12 male connector) in combination with the CDB650 or when using the cable with the open end (17-pin, M12 female connector/open end), switching outputs IN/OUT 3 ... 6 are available.

If the wiring of the outputs is carried out via a connection module:

Connection module	Output signal switching device	Reference
CDB650-204	IN/OUT 3 ... 6 (RES/OUT 1 ... 4)	<a href="#">page 44</a>
CDM420-0006	IN/OUT 3 ... 4	<a href="#">page 53</a>

<sup>1</sup> Function planned



**NOTE**

Capacitive loads on the switching outputs have an effect on the switch-on and switch-off behavior. The maximum capacity of 100 nF is a limit value.

**6.5 CDB650-204 wiring connection module**

**6.5.1 Wiring overview for InspectorP63x ... 65x (1 switching input used)**

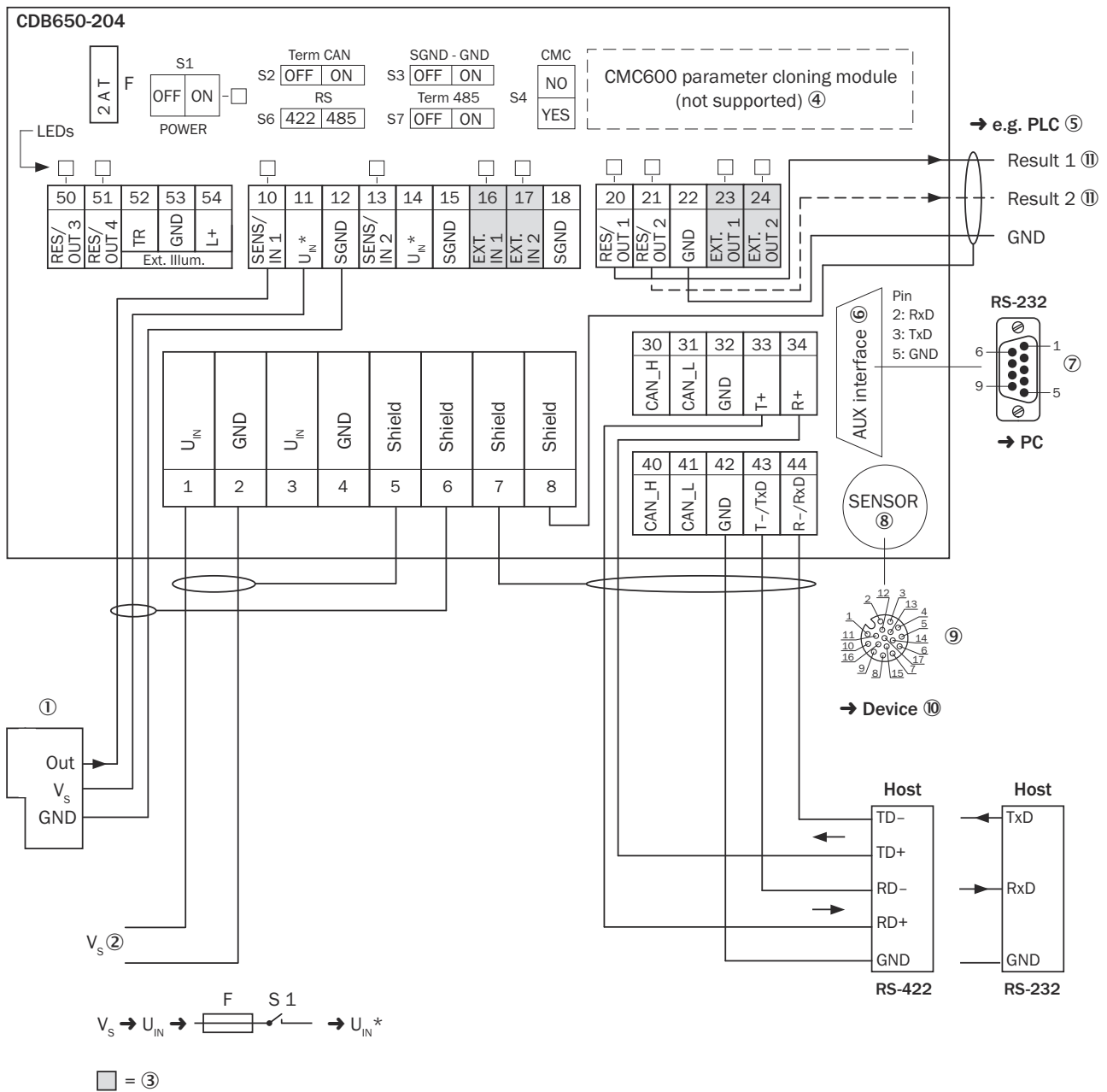

Figure 8: Connecting the device to the CDB650-204 connection module (overview)

- ① External trigger (e.g., photoelectric sensor)
- ② Supply voltage  $V_s = U_v$
- ③ External switching inputs and outputs (not supported)
- ④ CMC600 parameter cloning module (not supported)
- ⑤ E.g., PLC (programmable logic controller)
- ⑥ Auxiliary interface "AUX"
- ⑦ Male connector, D-Sub, 9-pin
- ⑧ Sensor = Device
- ⑨ Female connector, M12, 17-pin, A-coded
- ⑩ Device to be connected
- ⑪ Name of the switching output

6.5.2 Connecting supply voltage in the CDB650-204

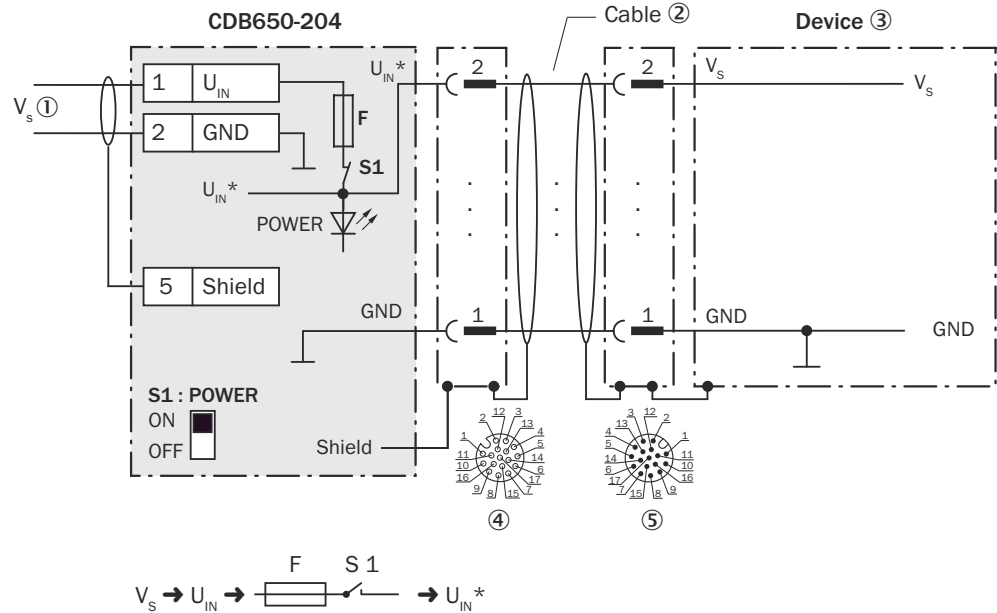

Figure 9: Connecting the device supply voltage in the CDB650-204 connection module

- ① Supply voltage  $V_s = U_V$
- ② Connecting cable 1:1 (female connector, M12, 17-pin, A-coded / male connector, M12, 17-pin, A-coded)
- ③ Device
- ④ Female connector, M12, 17-pin, A-coded
- ⑤ Male connector, M12, 17-pin, A-coded

Function switch S1

Table 3: Switch S1: power

Switch setting	Function
ON	Supply voltage $U_{IN}$ supplied to CDB650-204 and device via fuse as $U_{IN}^*$ . Voltage $U_{IN}^*$ also available at terminals 11 and 14.
OFF	CDB650-204 and device isolated from supply voltage. Recommended position for all connection work.

### 6.5.3 Wiring the serial host interface RS-232 in the CDB650-204

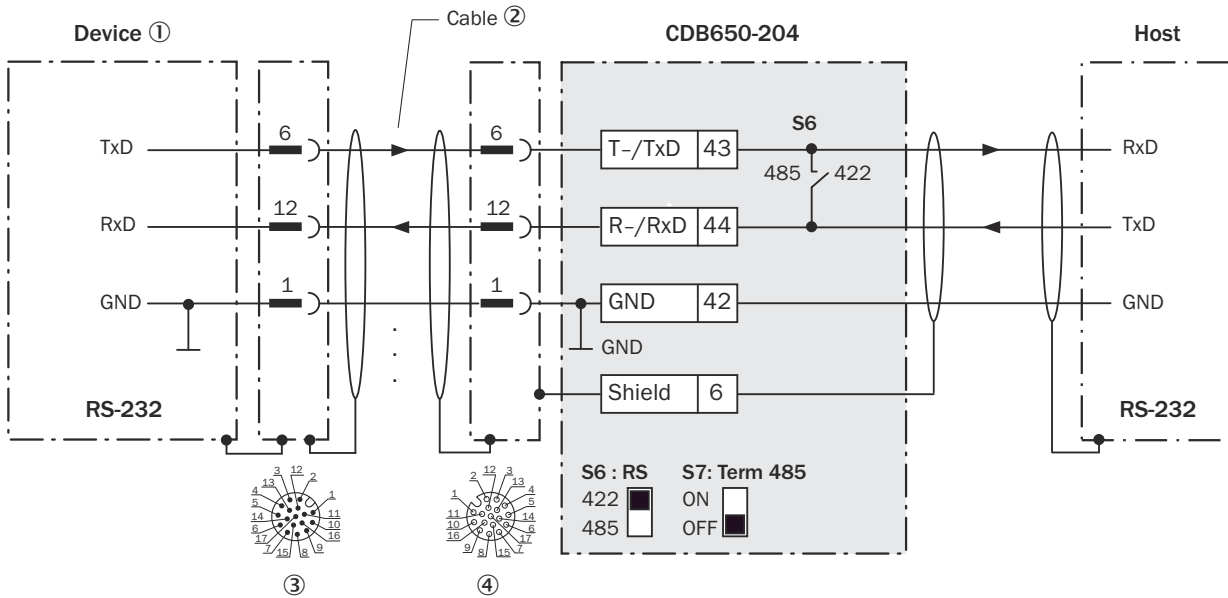

Figure 10: Wiring the RS-232 data interface

- ① Device
- ② 1:1 connecting cable, e.g., part no. 6052286 (2 m)
- ③ Male connector, M12, 17-pin, A-coded
- ④ Female connector, M12, 17-pin, A-coded

### 6.5.4 Wiring the serial host interface RS-422 in the CDB650-204

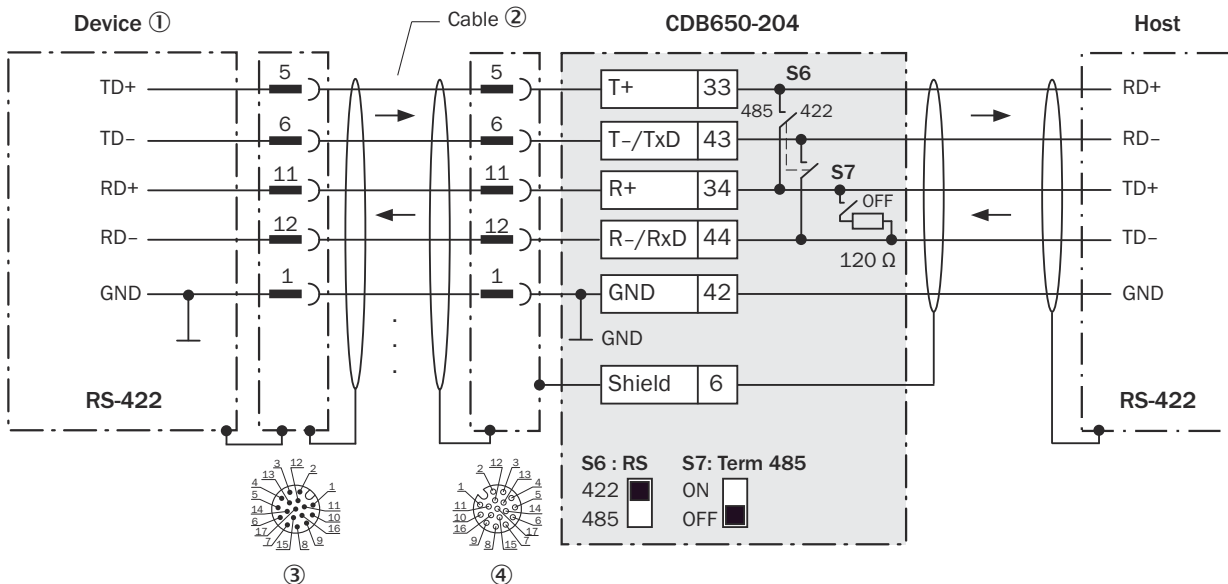

Figure 11: Wiring the RS-422 data interface

- ① Device
- ② Connecting cable 1:1 (female connector, M12, 17-pin, A-coded / male connector, M12, 17-pin, A-coded)
- ③ Male connector, M12, 17-pin, A-coded
- ④ Female connector, M12, 17-pin, A-coded

### Function switch S7

Table 4: Switch S7: Term 485

Switch setting	Function
ON	Terminates the RS-422 receiver in the device in order to improve the interference distance to the cable.
OFF	No termination



#### NOTE

Use of the RS-422 data interface:

- The relevant interface drivers of the device comply with the standard for RS-422.
  - Activation of the interface in the device with AppStudio configuration software (point-to-point).
  - The connection shown above is configured for operation of the host with permanently activated drivers (often described as “RS-422 operation”).
-



6.5.5 Wiring the CAN interface in the CDB650-204

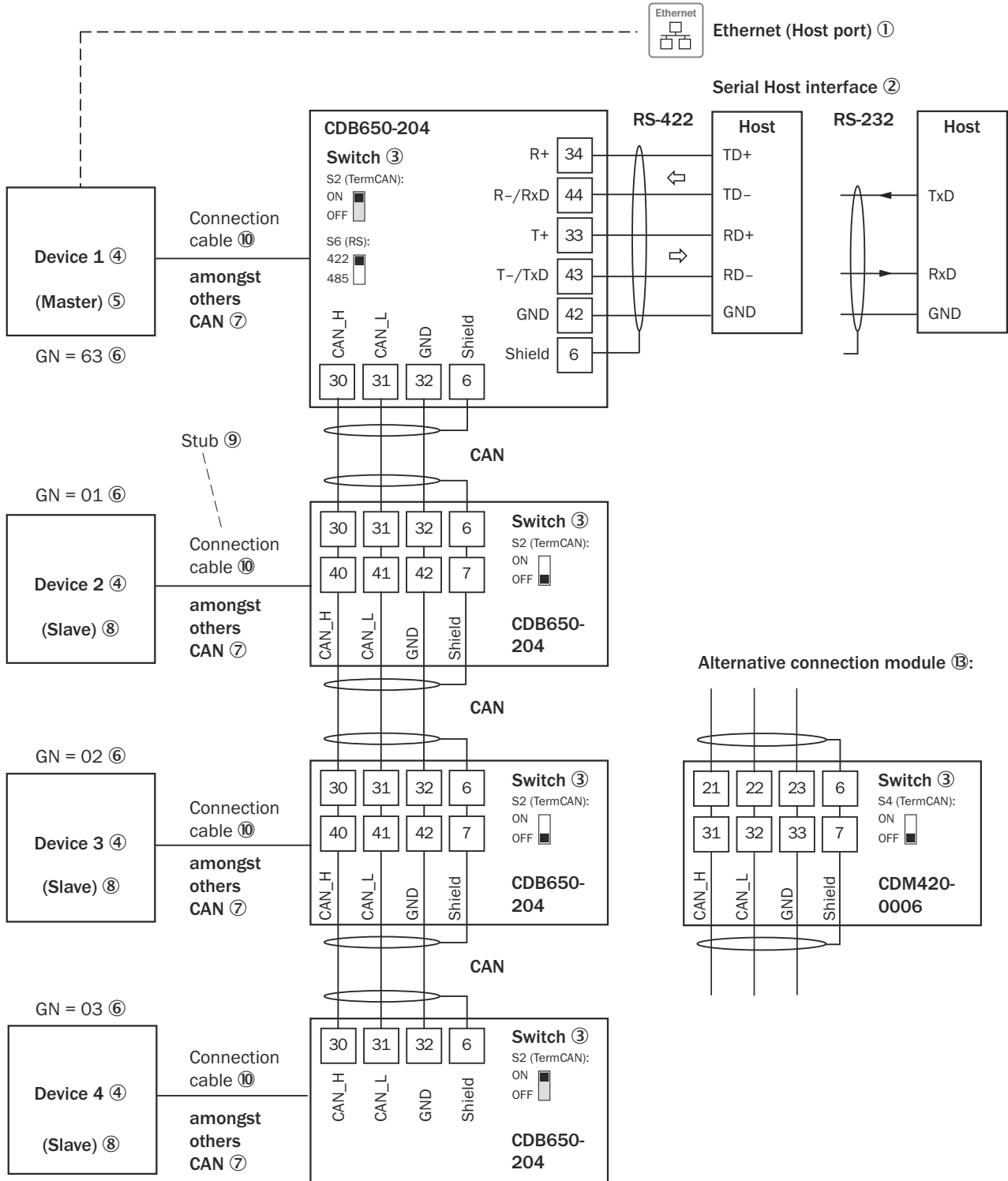

GN = Device number ⑪  
(max. 32 participants) ⑫

Figure 12: Wiring the CAN interface of the device in the CDB650-204 connection module Connection and looping of the supply voltage and connection of the trigger sensor, e.g., to the master not discussed here!

- ① Ethernet (host port)
- ② Serial host interface

- ③ Switch
- ④ Device
- ⑤ Master
- ⑥ Device number
- ⑦ CAN, for example
- ⑧ Slave
- ⑨ Stub cable
- ⑩ Connecting cable 1:1 (female connector, M12, 17-pin, A-coded / male connector, M12, 17-pin, A-coded)
- ⑪ Device number
- ⑫ Max. 32 nodes
- ⑬ Alternative connection module An adapter cable (female connector, M12, 17-pin, A-coded / male connector, D-Sub-HD, 15-pin) is required to connect the device

**6.5.6 Wiring switching inputs “Sensor 1” and “Sensor 2” in the CDB650-204**

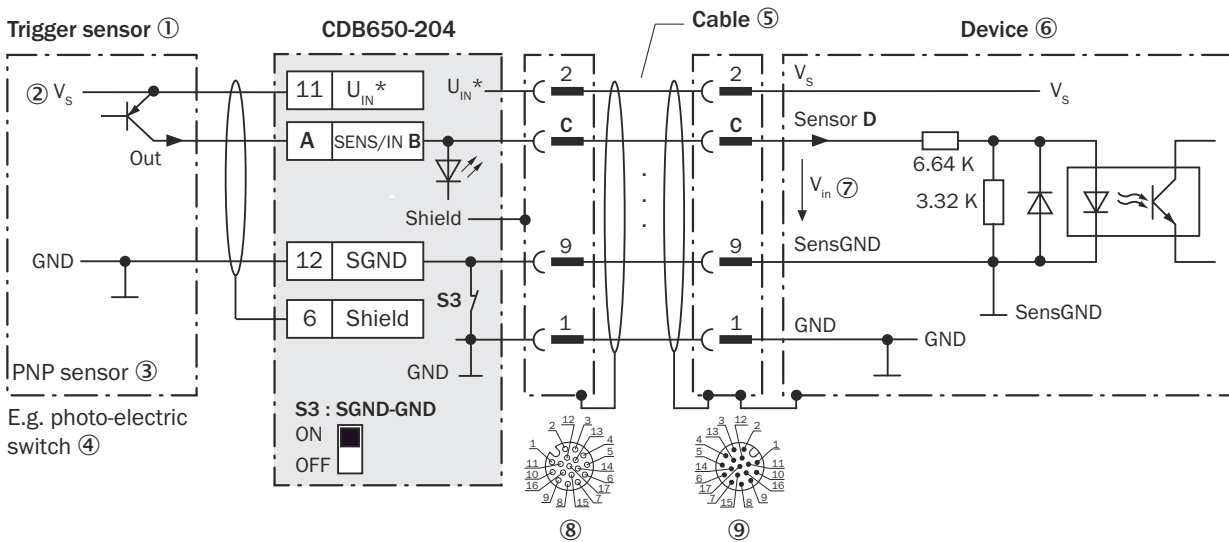

Figure 13: Trigger sensor powered by the CDB650-204

- ① Trigger sensor
- ② Supply voltage  $V_s = U_v$
- ③ PNP sensor
- ④ E.g., photoelectric sensor
- ⑤ Connecting cable 1:1 (female connector, M12, 17-pin, A-coded / male connector, M12, 17-pin, A-coded)
- ⑥ Device
- ⑦ Input voltage  $V_{in} = U_e$ . Maximum DC 30 V.
- ⑧ Female connector, M12, 17-pin, A-coded
- ⑨ Male connector, M12, 17-pin, A-coded

Table 5: Assignment of placeholders to the switching inputs

CDB650-204			Device
Terminal A	Signal B	Pin C	Sensor D
10	SENS/IN 1	10	1
13	SENS/IN 2	15	2

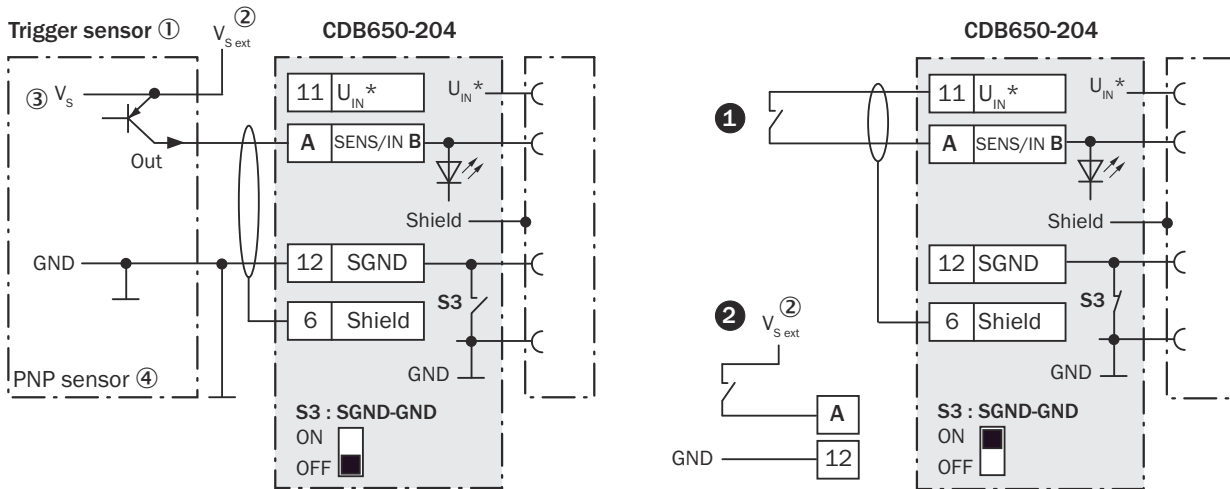

Figure 14: Left: trigger sensor connected volt-free and powered externally. Right: alternative switch, ❶ powered by CDB650-204 or ❷ connected volt-free and powered externally. Switch setting S3 as in the left-hand figure.

- ❶ Trigger sensor
- ❷ External supply voltage  $V_{S\ ext} = U_{V\ ext}$
- ❸ Supply voltage  $V_S = U_V$
- ❹ PNP sensor

### Function switch S3

Table 6: Switch S3: SGND - GND

Switch setting	Function
ON	GND of the trigger sensor connected to GND of the CDB650-204 and GND of the device
OFF	Trigger sensor connected to the CDB650-204 and the device volt-free. The shared, insulated reference potential for all switching inputs = SGND.

### Characteristic data for digital switching inputs

Table 7: Characteristic data for the switching inputs "Sensor 1" and "Sensor 2"

<b>Logic</b>	Power to the input starts the assigned function, e.g. Start analysis . Default setting for device: logic not inverted (active high), debouncing 10 ms
<b>Properties</b>	<ul style="list-style-type: none"> <li>• Opto-decoupled, reverse-polarity protected</li> <li>• Can be wired with PNP output of a trigger sensor</li> </ul>
<b>Electrical values</b>	Low: $U_e \leq 2\text{ V}$ ; $I_e \leq 0.3\text{ mA}$ High: $6\text{ V} \leq U_e \leq 30\text{ V}$ ; $0.7\text{ mA} \leq I_e \leq 5\text{ mA}$



#### NOTE

Functional assignment for the switching inputs is done with AppStudio configuration software.

### 6.5.7 Wiring IN/OUT 3 ... 6 of the device in the CDB650-204

These outputs can be configured independently as IN and OUT. Default: IN

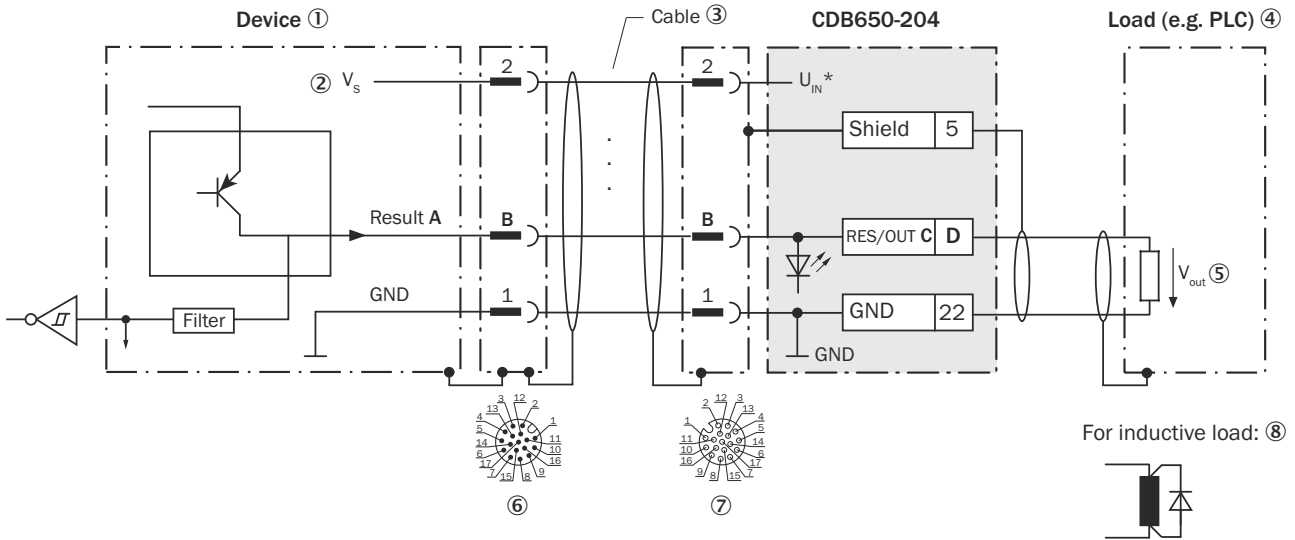

Figure 15: Wire the switching outputs

- ① Device
- ② Supply voltage  $V_s = U_v$
- ③ Connecting cable 1:1, e.g. part number 6052286 (2 m)
- ④ Load (e.g. PLC)
- ⑤ Output voltage  $V_{out} = U_a$
- ⑥ Male connector, M12, 17-pin, A-coded
- ⑦ Female connector, M12, 17-pin, A-coded
- ⑧ With inductive load: see note

**Inductive load**



**NOTE**

Provide a arc-suppression switch at the switching output if inductive load is present. Attach a freewheeling diode directly to the load.

Table 8: Assignment of placeholders to switching outputs

Device		CDB650-204	
Output A	Pin B	Signal C	Terminal D
IN/OUT 3	13	Res/Out 1	20
IN/OUT 4	14	Res/Out 2	21
IN/OUT 5	16	Res/Out 3	50
IN/OUT 6	17	Res/Out 4	51

**Characteristic data, digital IN/OUT used as switching output (OUT)**

Table 9: Characteristic data of "IN/OUT 3" to "IN/OUT 6" switching outputs

<b>Switching behavior</b>	PNP switching to supply voltage $U_v$ . Default settings in the device: no function, logic: not inverted (active high)
<b>Properties</b>	<ul style="list-style-type: none"> <li>• Short-circuit protected + temperature protected</li> <li>• Not electrically isolated from <math>U_v</math></li> </ul>
<b>Electrical values</b>	$0\text{ V} \leq U_a \leq U_v$ $(U_v - 1.5\text{ V}) \leq U_a \leq U_v$ at $I_a \leq 100\text{ mA}$

**NOTE**

Functional assignment for the switching outputs is done with AppStudio.

**6.5.8 Wiring a digital switching input in configurable switching inputs****Characteristic data for digital IN/OUT used as a switching input (IN)**

V2D65x

- Low:  $U_e \leq 5 \text{ V}$ ;  $I_e \leq 0.3 \text{ mA}$
- High:  $12 \text{ V} \leq U_e \leq U_V$ ;  $I_e \leq 1 \text{ mA}$

For the purpose of electromagnetic compatibility, inputs must be set to a defined low-impedance level!

**6.6 CDM420-0006 wiring connection module****6.6.1 Wiring overview for InspectorP63x ... 65x (1 switching input used)**

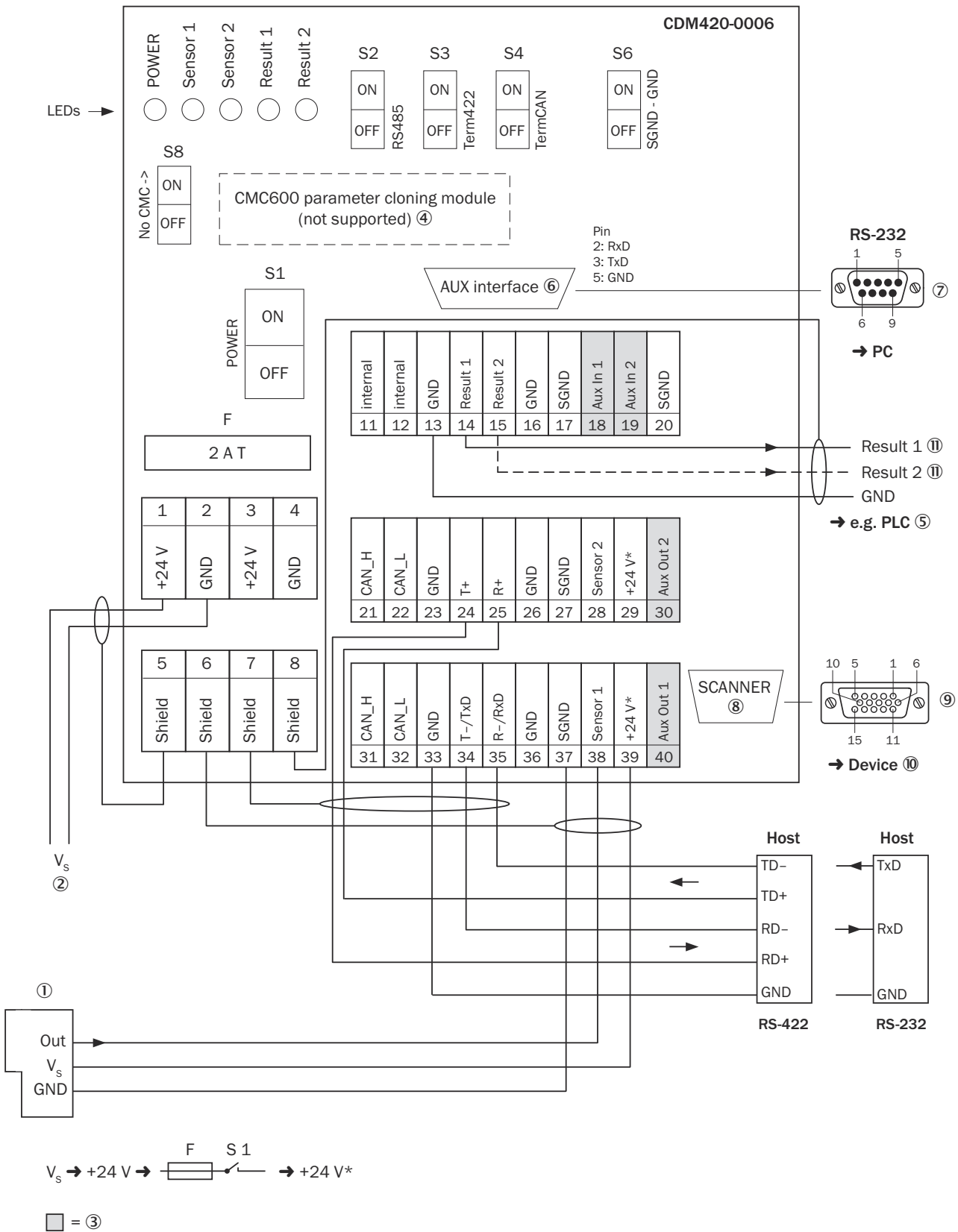

Figure 16: Connecting the device to the CDM420-0006 connection module (overview)

- ① External trigger (e.g., photoelectric sensor)
- ② Supply voltage  $V_s = U^v$
- ③ Switching inputs and outputs (not supported)

- ④ CMC600 parameter cloning module (not supported)
- ⑤ E.g., PLC (programmable logic controller)
- ⑥ Auxiliary interface "AUX"
- ⑦ Male connector, D-Sub, 9-pin
- ⑧ Sensor = Device
- ⑨ Female connector, D-Sub-HD, 15-pin
- ⑩ Device to be connected
- ⑪ Name of the switching output

### 6.6.2 Connecting supply voltage in the CDM420-0006

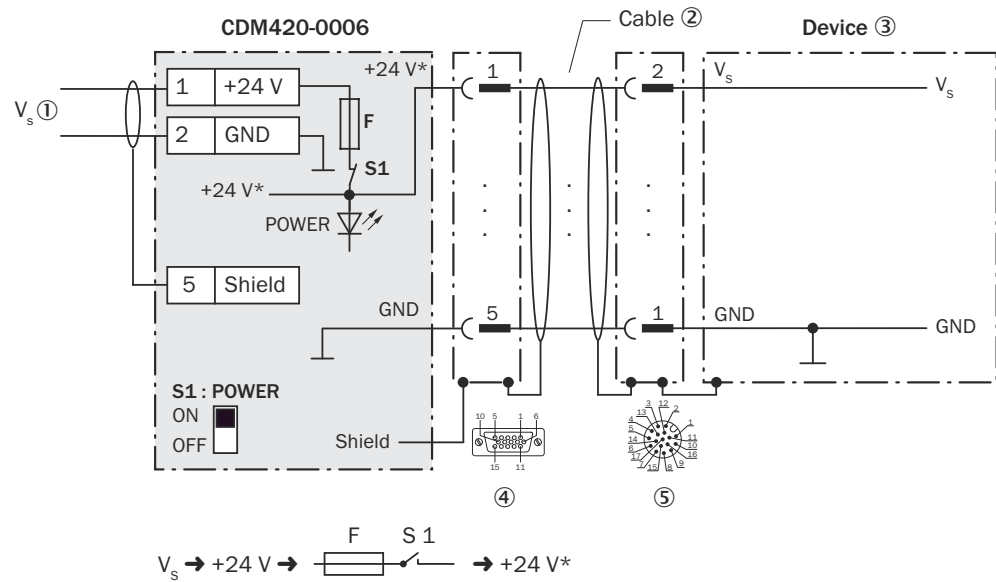

Figure 17: Connecting the device supply voltage in the CDM420-0006 connection module

- ① Supply voltage  $V_s = U_V$
- ② Adapter cable, e.g., part no. 2055419 (2 m)
- ③ Device
- ④ Female connector, D-Sub-HD, 15-pin
- ⑤ Male connector, M12, 17-pin, A-coded

#### Function switch S1

Table 10: Switch S1: power

Switch setting	Function
ON	+24 V supply voltage supplied to CDM420-0006 and device via fuse as +24 V*. +24 V* voltage also available at terminals 29 and 39.
OFF	CDM420-0006 and device isolated from supply voltage. Recommended position for all connection work.

6.6.3 Wiring the serial host interface RS-232 in the CDM420-0006

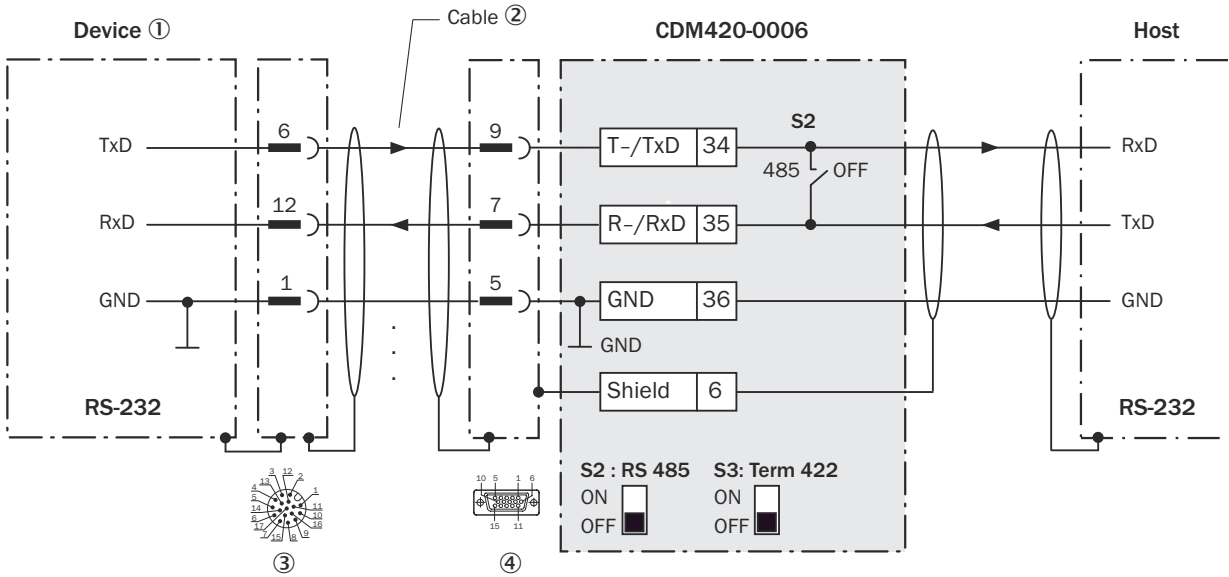

Figure 18: Wiring the RS-232 data interface

- ① Device
- ② Adapter cable, e.g., part no. 2055419 (2 m)
- ③ Male connector, M12, 17-pin, A-coded
- ④ Female connector, D-Sub-HD, 15-pin

6.6.4 Wiring the serial host interface RS-422 in the CDM420-0006

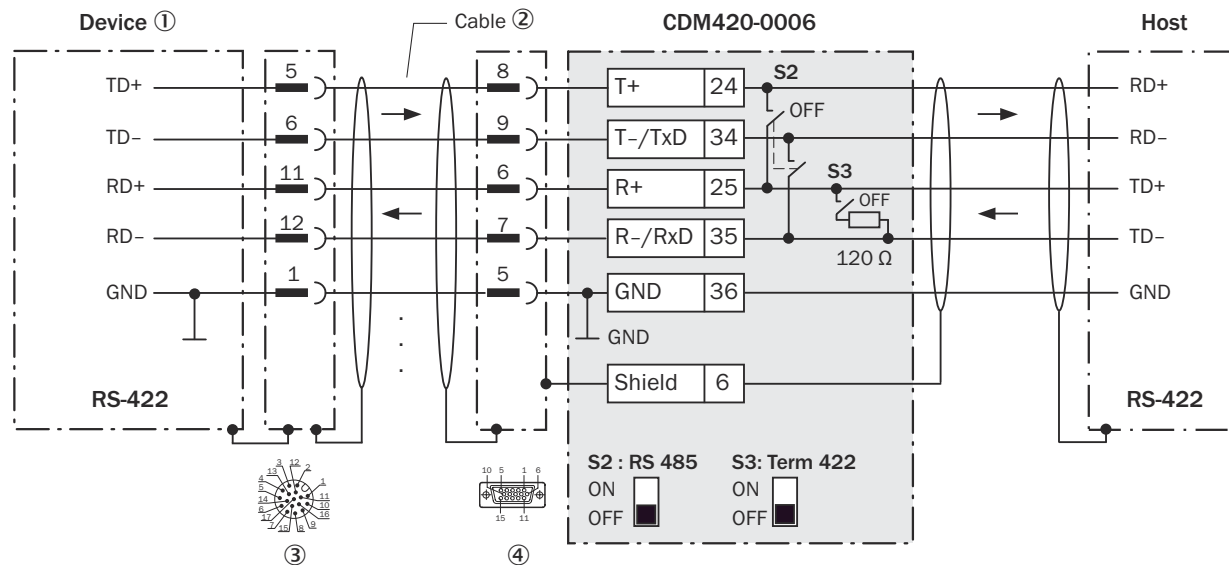

Figure 19: Wiring the RS-422 data interface

- ① Device
- ② Adapter cable, e.g., part no. 2055419 (2 m)
- ③ Male connector, M12, 17-pin, A-coded
- ④ Female connector, D-Sub-HD, 15-pin



**Function switch S3***Table 11: Switch S3: Term 485*

Switch setting	Function
ON	Terminates the RS-422 receiver in the device in order to improve the interference distance to the cable.
OFF	No termination

**NOTE**

Use of the RS-422 data interface:

- The relevant interface drivers of the device comply with the standard for RS-422.
- Activation of the interface in the device with AppStudio configuration software (point-to-point).
- The connection shown above is configured for operation of the host with permanently activated drivers (often described as “RS-422 operation”).

6.6.5 Wiring the CAN interface in the CDM420-0006

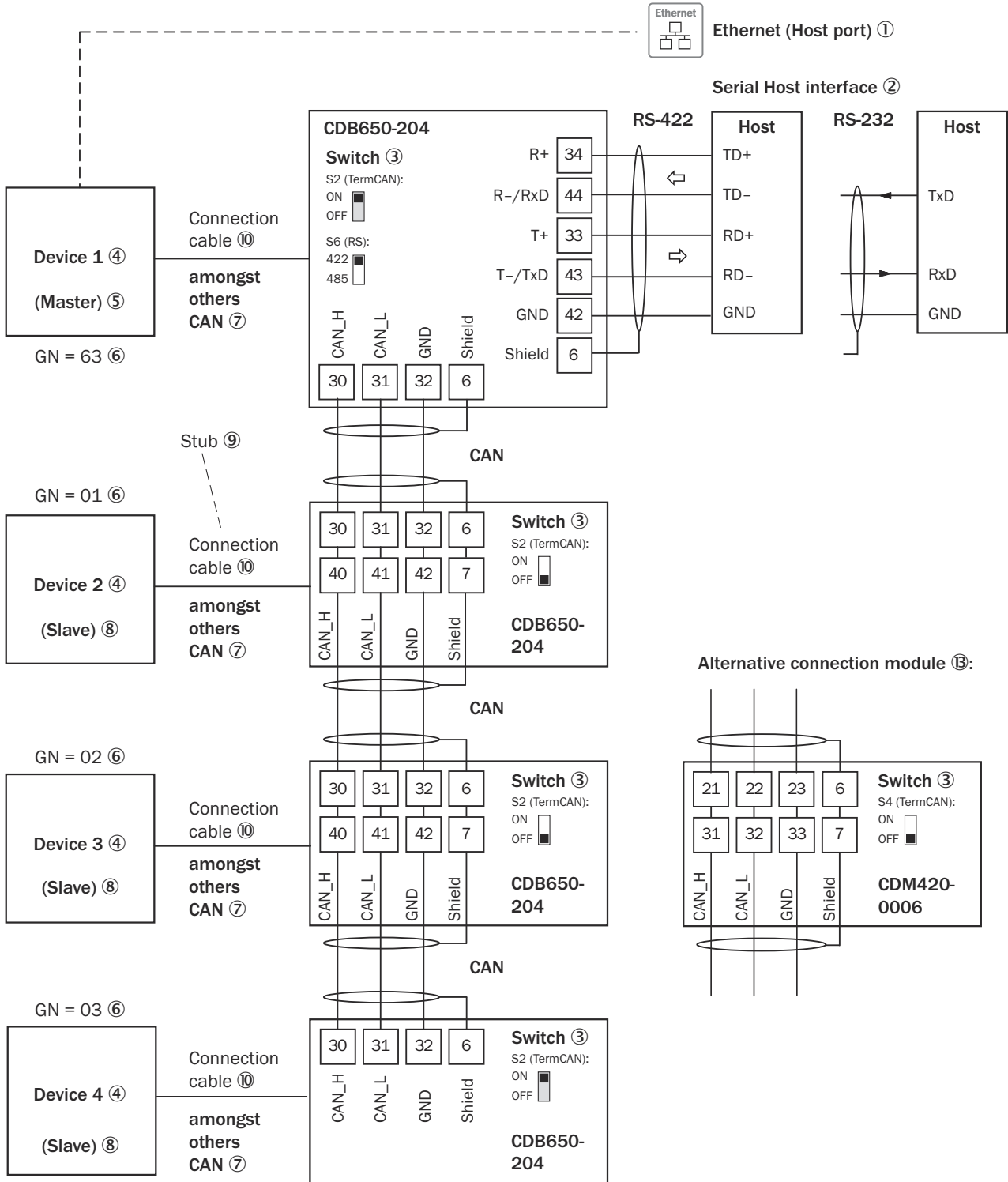

GN = Device number ⑪  
(max. 32 participants) ⑫

Figure 20: Wiring the CAN interface of the device in the CDM420-0006 connection module Connection and looping of the supply voltage and connection of the trigger sensor, e.g., to the master not discussed here!

- ① Ethernet (host port)
- ② Serial host interface

- ③ Switch
- ④ Device
- ⑤ Master
- ⑥ Device number
- ⑦ CAN, for example
- ⑧ Slave
- ⑨ Stub cable
- ⑩ Adapter cable, e.g., part no. 2055419 (2 m)
- ⑪ Device number
- ⑫ Max. 32 nodes
- ⑬ Alternative connection module: in order to connect the device, a 1:1 connecting cable is required, e.g. part no. 6052286 (2 m)

### 6.6.6 Wiring the switching inputs “Sensor 1” and “Sensor 2” in the CDM420-0006

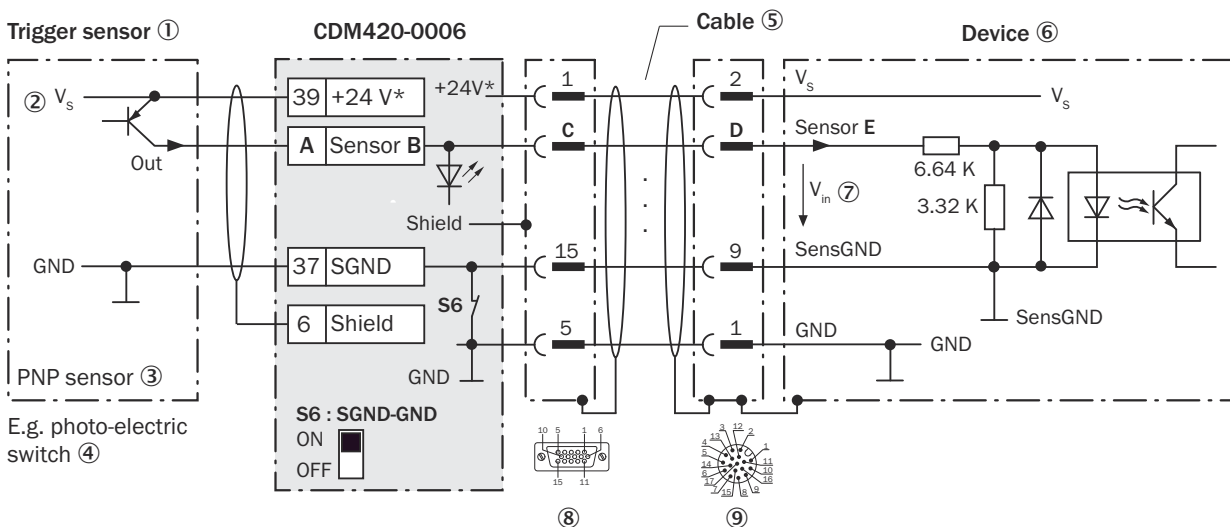

Figure 21: Trigger sensor powered by the CDM420-0006

- ① Trigger sensor
- ② Supply voltage  $V_s = U_v$
- ③ PNP sensor
- ④ E.g., photoelectric sensor
- ⑤ Adapter cable, e.g., part no. 2055419 (2 m)
- ⑥ Device
- ⑦ Input voltage  $V_{IN} = U_e$ . Maximum DC 30 V.
- ⑧ Female connector, D-Sub-HD, 15-pin
- ⑨ Male connector, M12, 17-pin, A-coded

Table 12: Assignment of placeholders to the switching inputs

CDM420-0006			Device	
Terminal A	Signal B	Pin C	Pin D	Sensor E
38	Sensor 1	14	10	1
28	Sensor 2	4	15	2

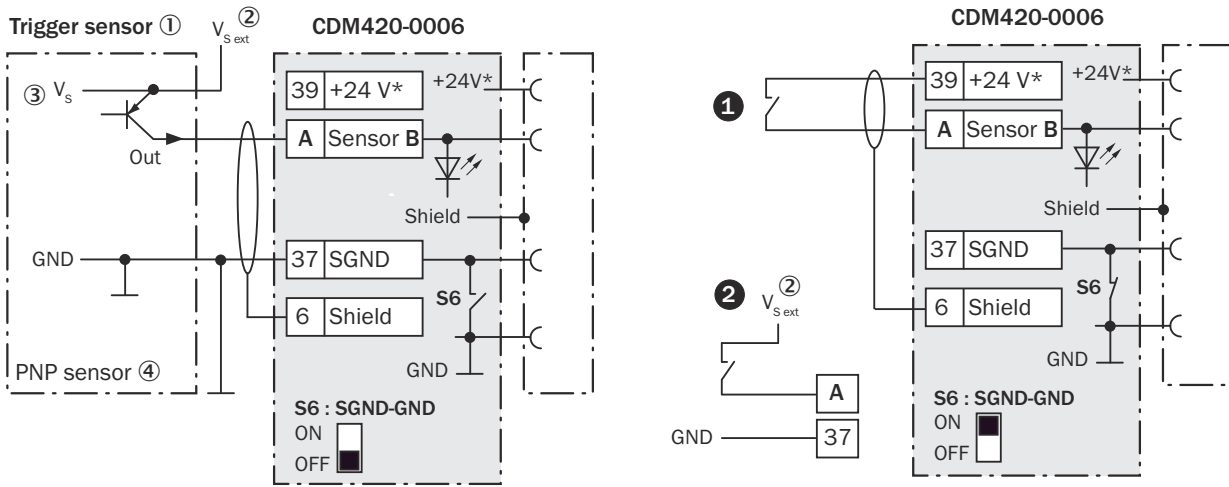

Figure 22: Left: trigger sensor connected volt-free and powered externally. Right: alternative switch, ❶ powered by CDM420-0006 or ❷ connected volt-free and powered externally. Switch setting S6 as in the left-hand figure.

- ❶ Trigger sensor
- ❷ External supply voltage  $V_{S\ ext} = U_{V\ ext}$
- ❸ Supply voltage  $V_s = U_v$
- ❹ PNP sensor

**Function switch S6**

Table 13: Switch S6: SGND - GND

Switch setting	Function
ON	GND of the trigger sensor connected to GND of the CDM420-0006 and GND of the device
OFF	Trigger sensor connected to the CDM420-0006 and the device volt-free. The shared, insulated reference potential for all switching inputs = SGND.

**Characteristic data for digital switching inputs**

Table 14: Characteristic data for the switching inputs “Sensor 1” and “Sensor 2”

<b>Logic</b>	Current to input starts the assigned function, e.g., start trigger. Default setting for device: logic not inverted (active high), debouncing 10 ms
<b>Properties</b>	<ul style="list-style-type: none"> <li>• Opto-decoupled, reverse-polarity protected</li> <li>• Can be wired with PNP output of a trigger sensor</li> </ul>
<b>Electrical values</b>	Low: $U_e \leq 2\ V$ ; $I_e \leq 0.3\ mA$ High: $6\ V \leq U_e \leq 30\ V$ ; $0.7\ mA \leq I_e \leq 5\ mA$



**NOTE**

Functional assignment for the switching inputs is done with AppStudio configuration software.

## 6.6.7 Wiring "IN/OUT 3" and "IN/OUT 4" switching outputs in the CDM420-0006

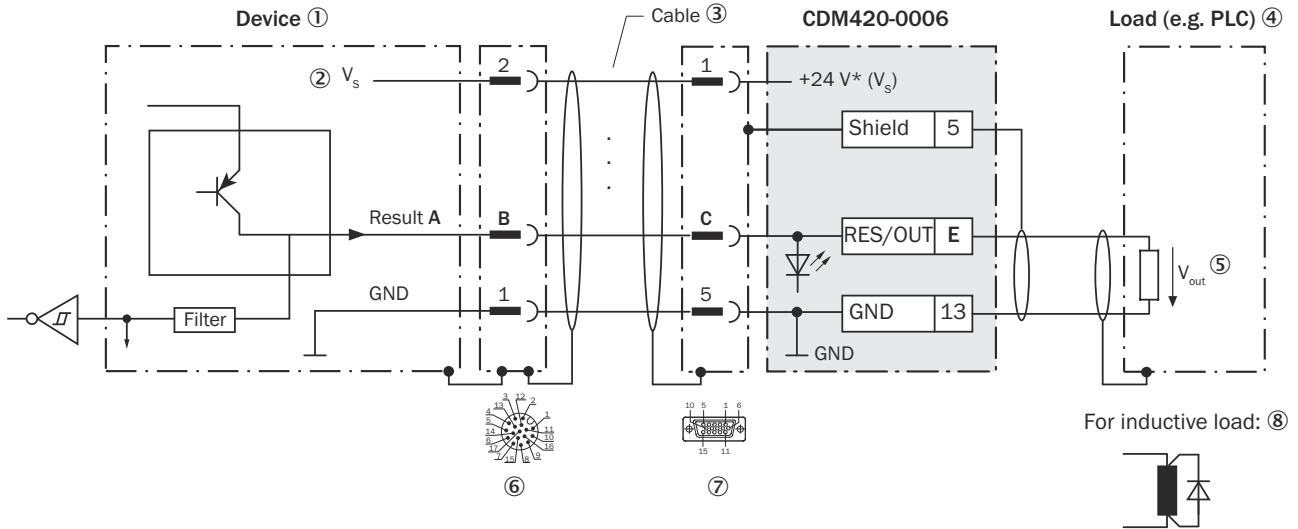

- ① Device
- ② Supply voltage  $V_s = U_v$
- ③ Adapter cable 1:1, e.g. part number 2055419 (2 m)
- ④ Load (e.g. PLC)
- ⑤ Output voltage  $V_{out} = U_a$
- ⑥ Male connector, M12, 17-pin, A-coded
- ⑦ Female connector, D-Sub-HD, 15-pin
- ⑧ With inductive load: see note

## Inductive load



## NOTE

Provide a arc-suppression switch on the switching output if inductive load present. Attach a freewheeling diode directly on the load.

Table 15: Assignment of placeholders to switching outputs

Device		CDM420-0006		
Output A	Pin B	Pin C	Signal D	Terminal E
IN/OUT 3	13	12	Result 1	14
IN/OUT 4	14	13	Result 2	15

## Characteristic data, IN/OUT used as switching output (OUT)

Table 16: Characteristic data of "IN/OUT 3" and "IN/OUT 4" switching outputs

Logic	PNP switching to supply voltage +24 V* Settings in the device: no function, logic: not inverted (active high)
Properties	<ul style="list-style-type: none"> <li>• Short-circuit protected + temperature protected</li> <li>• Not electrically isolated from supply voltage +24 V*</li> </ul>
Electrical values	$0 \text{ V} \leq U_a \leq +24 \text{ V}^*$ $(+24 \text{ V}^* - 1.5 \text{ V}) \leq U_a \leq +24 \text{ V}^*$ at $I_a \leq 100 \text{ mA}$



## NOTE

Functional assignment for the switching outputs is done with AppStudio.

### 6.6.8 Wiring a digital switching input in configurable switching inputs

#### Characteristic data for digital IN/OUT used as a switching input (IN)

V2D65x

- Low:  $U_e \leq 5 \text{ V}$ ;  $I_e \leq 0.3 \text{ mA}$
- High:  $12 \text{ V} \leq U_e \leq U_V$ ;  $I_e \leq 1 \text{ mA}$

For the purpose of electromagnetic compatibility, inputs must be set to a defined low-impedance level!

## 7 Commissioning

### 7.1 Installing SensorApps and programming the device



#### NOTICE

Update the device firmware version before you start using the device. Always use the latest version, unless there is a specific need to use an older version. Download the latest version of the firmware from the SICK Support Portal ([supportportal.sick.com](https://supportportal.sick.com)) and install it using SICK AppManager.

#### Installing SensorApps on the device

Use the SICK AppManager software to manage and install SensorApp packages (\*.sapk files) on the device. The latest version of SICK AppManager is available from [www.sick.com/SICK\\_AppManager](https://www.sick.com/SICK_AppManager).

Many SensorApps have a web user interface which is accessed by following the steps below:

1. Open a Google Chrome web browser window.
2. Type the IP address of the device. The default IP address is 192.168.0.1.

#### Installing and starting the development environment

The SICK AppStudio development environment is used by default to program the device and to perform diagnostics in case of faults.

1. Download and install the latest version of SICK AppStudio from [www.sick.com/SICK\\_AppStudio](https://www.sick.com/SICK_AppStudio). Administrator rights may be required on the PC to install the software.
2. Enter your personal license key to complete the installation.
3. Start the program. Path: **Start > All programs > SICK > SICK AppStudio**
4. Establish a connection between the software and the device via Ethernet.
- ✓ The connection wizard starts automatically.
5. The following IP address is configured by default on the device:
  - IP address P1: 192.168.0.1

#### First steps with the device

The device is supplied with a pre-installed SensorApp called ImageSetup.

1. In SICK AppStudio, double-click the paths in the AppExplorer to display all content.
2. Double-click the primary script file to open it in the script editor and display the source code.

#### Receiving images

1. Click on the corresponding button to start all apps.
2. The device page (in online mode) will now display an image on the right-hand side, enabling basic configuration to adjust parameters such as illumination, gain, contrast, and trigger methods.



#### NOTE

If the device page displays Error 404, port 80 is already occupied by another piece of software. To find out which process you need to quit, go to Task Manager > Performance tab > Resource monitor > Network tab.

Search for port 80 among the listed ports.

### **C-mount lens: adjusting the brightness and sharpness**

1. Remove the protective optics cover.
2. Loosen the lock nut fitting on the aperture ring and sharpness ring.
3. Adjust the mask using the aperture ring (top ring) on the lens to a low value such as “2”.
4. Reduce the **shutter time** and **brightness** until the object is clearly visible on the image.
5. Increase the image sharpness using the sharpness ring (bottom ring) on the lens. The object must be clearly displayed in sharp focus so that all edges are easy to identify.
6. Use the lock nut fitting to fix the sharpness ring setting in place.
7. Apply the correct mask setting for the depth of field. In order to do this, check the settings with the test object. Adjust the mask to a higher value. If a greater depth of field is required, select a higher value. Bear in mind that using a greater mask value reduces image brightness, meaning that brightness must be increased using the software. This reduces image quality.
8. Fix the aperture ring using the lock nut fitting.
9. Mount the protective optics cover.

### **Continuing programming**

- ▶ Adjust the settings for additional functions during planned operation such as triggers, result formats, data interface, etc.

### **Quitting programming**

1. Save the program in the non-volatile memory of the device.
2. Save the parameter set on the PC.



## 8 Maintenance

### 8.1 Maintenance plan

### 8.2 Cleaning

Cleaning includes the viewing window and the housing of the device.



#### NOTICE

##### Equipment damage due to improper cleaning.

Improper cleaning may result in equipment damage.

- Only use recommended cleaning agents.
- Never use sharp objects for cleaning.

#### Cleaning the inspection window

Check the viewing window of the device for accumulated dirt at regular intervals. This is especially relevant in harsh operating environments (dust, abrasion, damp, fingerprints, etc.).

The inspection window lens must be kept clean and dry during operation.



#### NOTE

Static charging may cause dust particles to stick to the inspection window. This effect can be reduced by using an anti-static cleaning agent in combination with the SICK lens cloth (part no. 4003353) (can be obtained from [www.sick.com](http://www.sick.com)).



#### NOTICE

##### Damage to the inspection window/.

Reduced analysis performance due to scratches or streaks on the window.

- Clean the window only when wet.
- Use a mild cleaning agent that does not contain powder additives. Do not use aggressive cleaning agents, such as acetone, etc.
- Avoid any movements that could cause scratches or abrasions on the window.
- Only use cleaning agents suitable for the screen material.

The type of screen material used in the inspection window can be found on the type label (see "Type code", page 12).

#### Cleaning procedure:



#### CAUTION

##### Optical radiation: Laser class 1M

The accessible radiation does not pose a danger when viewed directly for up to 100 seconds. It may pose a danger to the eyes and skin in the event of incorrect use.

- Never look directly at the laser beam using optical instruments. Optical instruments include magnifying glasses, microscopes, telescopes and binoculars.
- Do not open the housing. Opening the housing may increase the level of risk.
- Current national regulations regarding laser protection must be observed.



### CAUTION

#### Warning! Optical radiation: LED risk group 1

The LEDs may pose a danger to the eyes and skin in the event of incorrect use.

- Protect the eyes and skin against radiation.
  - Use suitable eye protection.
  - Use protective measures such as a screen to shield the radiation.
  - Do not open the housing. Opening the housing will not switch off the light source. Opening the housing may increase the level of risk.
  - Comply with the current national regulations on photobiological security of lamps and lamp systems.
- 



### CAUTION

#### Warning! Optical radiation: LED risk group 2

The LEDs may pose a danger to the eyes in the event of incorrect use.

- Protect the eyes and skin against radiation.
  - Use suitable eye protection.
  - Never point the light source at people.
  - Use protective measures such as a screen to shield the radiation.
  - Avoid any reflections on people from reflective surfaces. Be particularly careful during mounting and alignment work.
  - Do not open the housing. Opening the housing will not switch off the light source. Opening the housing may increase the level of risk.
  - Comply with the current national regulations on photobiological security of lamps and lamp systems.
- 

#### For both radiation types:

It is not possible to entirely rule out temporary disorienting optical effects, particularly in conditions of dim lighting. Disorienting optical effects may come in the form of dazzle, flash blindness, afterimages, photosensitive epilepsy, depending on parameterization), or impairment of color vision, for example.

---



### CAUTION

#### Hazardous radiation.

If any operating or adjusting devices other than those specified here are used or other methods are employed, this can lead to dangerous exposure to radiation. Damage to the eyes is possible.

- If the product is operated in conjunction with external illumination systems, the risks described here may be exceeded. This must be taken into consideration by users on a case-by-case basis.
  - Do not look into the light source when it is switched on.
  - Comply with the latest version of the applicable regulations on photobiological safety of lamps and lamp systems as well as on laser protection.
- 

Only the illumination units from SICK intended for the application can be used as internal illumination units.

- ▶ Switch off the device for the duration of the cleaning operation. If this is not possible, use suitable laser protection goggles. These must absorb radiation of the device's wavelength effectively.
- ▶ Glass window: remove dust from the viewing window using a soft, clean brush. If necessary, also clean the viewing window with a clean, damp, lint-free cloth, and a mild anti-static lens cleaning fluid.
- ▶ Plastic window: clean the viewing window only with a clean, damp, lint-free cloth, and a mild anti-static lens cleaning fluid.



---

**NOTICE**

If the inspection window is scratched or damaged (cracked or broken), the lens must be replaced. Contact SICK Support to arrange this.

- If the inspection window is cracked or broken, take the device out of operation immediately for safety reasons and have it repaired by SICK.
- 

## 8.3 Repairs

Repair work on the device may only be performed by qualified and authorized personnel from SICK AG. Interruptions or modifications to the device by the customer will invalidate any warranty claims against SICK AG.

## 9 Troubleshooting

### 9.1 Overview of possible errors and faults

Table 17: Errors and faults

Situation	Error/fault
Mounting	<ul style="list-style-type: none"> <li>■ Device poorly aligned to the object (e.g. dazzle).</li> </ul>
Electrical installation	<ul style="list-style-type: none"> <li>■ Data interfaces of the device incorrectly wired.</li> </ul>
Programming	<ul style="list-style-type: none"> <li>■ See SICK AppSpace interface documentation (troubleshooting of individual objects and functions).</li> </ul>
Operation	<ul style="list-style-type: none"> <li>■ Trigger control incorrect and/or not suitable for the object.</li> <li>■ Device faults (hardware/software).</li> </ul>

### 9.2 SICK Support

If the fault cannot be rectified, the device may be defective.

The device must not be repaired by the user. Interrupting or modifying the device will invalidate any warranty claims against SICK AG.

Rapid replacement of a device by the user is, however, possible.

- ▶ Where a fault cannot be rectified, make contact with the SICK Service department. To find your representative, see the final page of this document.



#### NOTE

Before calling, make a note of all type label data such as type designation, serial number, etc. to ensure faster telephone processing.

### 9.3 Returns

- ▶ Do not dispatch devices to the SICK Service department without consultation.
- ▶ The device must be sent in the original packaging or an equivalent padded packaging.



#### NOTE

To enable efficient processing and allow us to determine the cause quickly, please include the following when making a return:

- Details of the contact person
- Description of the application
- Description of the fault that occurred

## 10 Decommissioning

### 10.1 Disposal

If a device can no longer be used, dispose of it in an environmentally friendly manner in accordance with the applicable country-specific waste disposal regulations. Do not dispose of the product along with household waste.



#### **NOTICE**

**Danger to the environment due to improper disposal of the device.**

Disposing of devices improperly may cause damage to the environment.

Therefore, observe the following information:

- Always observe the valid regulations on environmental protection.
  - Separate the recyclable materials by type and place them in recycling containers.
-

## 11 Technical data



**NOTE**

The relevant online data sheet for your product, including technical data, dimensional drawing, and connection diagrams can be downloaded, saved, and printed from the Internet:

- [www.sick.com/InspectorP64x](http://www.sick.com/InspectorP64x)
- [www.sick.com/InspectorP65x](http://www.sick.com/InspectorP65x)

### 11.1 Optics and Illumination

Type	InspectorP64x Flex (V2D64xP-MCxxxx) InspectorP65x Flex (V2D65xP-MCxxxx)	InspectorP65x DynamicFocus (V2D65xP-MExxxx)
Focus	Manual adjustment of the sharpness and aperture on the optional lens unit	Dynamic and externally triggered electrical focus adjustment for working distance
Illumination for field of view	Optional e.g., variants of the VI83I integrable illumination unit: 11 x LED, visible light. White ( $\lambda = 6,000 \pm 500$ K) Blue ( $\lambda = 455 \pm 20$ nm) Red ( $\lambda = 620 \pm 30$ nm)	11 x LED, visible light. White ( $\lambda = 6,000 \pm 500$ K) Blue ( $\lambda = 455 \pm 20$ nm)
Feedback LED (spot in field of view)	Optional e.g., variants of the VI83I integrable illumination unit: 1 x LED, visible light. Green ( $\lambda = 525 \pm 15$ nm)	1 x LED, visible light. Green ( $\lambda = 525 \pm 15$ nm)

Type	InspectorP64x Flex (V2D64xP-MCxxxx) InspectorP65x Flex (V2D65xP-MCxxxx)	InspectorP65x DynamicFocus (V2D65xP-MExxxx)
LED risk group of illumination unit	“White + Feedback LED” option “Blue – Medium + Feedback LED” option “Blue – Wide + Feedback LED” option <ul style="list-style-type: none"> <li>Risk group 1 (low risk) according to IEC 62471-1: 2006-07/EN 62471-1: 2008-09.</li> </ul> “Red + Feedback LED” option <b>Radiance:</b> $L_B < 10 \times 10^3 \text{ W}/(\text{m}^2\text{sr})$ within 100 s; at a distance of $\geq 200 \text{ mm}$ $L_R < 7 \times 10^5 \text{ W}/(\text{m}^2\text{sr})$ within 10 s; at a distance of $\geq 200 \text{ mm}$	“White + Feedback LED” option <ul style="list-style-type: none"> <li>Risk group 1 (low risk) according to IEC 62471-1: 2006-07/EN 62471-1: 2008-09.</li> </ul> <b>Radiance:</b> $L_B < 10 \times 10^3 \text{ W}/(\text{m}^2\text{sr})$ within 100 s; at a distance of $\geq 200 \text{ mm}$ $L_R < 7 \times 10^5 \text{ W}/(\text{m}^2\text{sr})$ within 10 s; at a distance of $\geq 200 \text{ mm}$
	“Blue – Narrow + Feedback LED” option <ul style="list-style-type: none"> <li>Risk group 2 (moderate risk) according to IEC 62471-1: 2006-07/EN 62471-1: 2008-09 due to exposure to blue light.</li> </ul> <b>Radiance:</b> $L_B < 10 \times 10^3 \text{ W}/(\text{m}^2\text{sr})$ within 50 s (RG 2); at a distance of $\geq 200 \text{ mm}$ $L_R < 7 \times 10^5 \text{ W}/(\text{m}^2\text{sr})$ within 10 s (RG 1); at a distance of $\geq 200 \text{ mm}$ Risk RG 1 (low risk) corresponding to $L_B < 10 \times 10^3 \text{ W}/(\text{m}^2\text{sr})$ within 100 s for distances $> 1 \text{ m}$ .	“Blue + Feedback LED” option <ul style="list-style-type: none"> <li>Risk group 2 (moderate risk) according to IEC 62471-1: 2006-07/EN 62471-1: 2008-09 due to exposure to blue light.</li> </ul> <b>Radiance:</b> $L_B < 10 \times 10^3 \text{ W}/(\text{m}^2\text{sr})$ within 50 s (RG 2); at a distance of $\geq 200 \text{ mm}$ $L_R < 7 \times 10^5 \text{ W}/(\text{m}^2\text{sr})$ within 10 s (RG 1); at a distance of $\geq 200 \text{ mm}$ Risk RG 1 (low risk) corresponding to $L_B < 10 \times 10^3 \text{ W}/(\text{m}^2\text{sr})$ within 100 s for distances $> 1 \text{ m}$ .
Aiming laser (field of view)	Visible light. Red ( $\lambda = 630 \text{ nm} \dots 680 \text{ nm}$ ), can be disengaged	
Laser class	Class 1M according to IEC 60825-1: 2007-03. Complies with 21 CFR 1040.10 except for tolerances according to Laser Notice no. 50 of June 24, 2007. $P < 1.40 \text{ mW}$	

## 11.2 Performance

Type	InspectorP64x Flex (V2D64xP-MCxxxx) InspectorP65x Flex (V2D65xP-MCxxxx)	InspectorP65x DynamicFocus (V2D65xP-MExxxx)
Working distance	see "InspectorP64x Flex", page 22 see "InspectorP652 Dynamic Focus", page 23	see "InspectorP652 Flex", page 24
Lens unit	Application-specific <a href="http://www.sick.com/InspectorP64x">www.sick.com/InspectorP64x</a> <a href="http://www.sick.com/InspectorP65x">www.sick.com/InspectorP65x</a>	see "Type code", page 12
Image sensor resolution	see "Type code", page 12	
Image sensor type	see "Type code", page 12	

Type	InspectorP64x Flex (V2D64xP-MCxxx) InspectorP65x Flex (V2D65xP-MCxxx)	InspectorP65x DynamicFocus (V2D65xP-MExxx)
Image recording rate	InspectorP64x Flex At 1.7 Mpx: 40 Hz InspectorP65x Flex At 2 Mpx: 70 Hz At 4 Mpx: 40 Hz	At 2 Mpx: 70 Hz At 4 Mpx: 40 Hz
Ambient light tolerance	2000 lx on surface	
Image memory	Internally 512 MB, externally on optional microSD memory card (max. 16 GB)	

## 11.3 Interfaces

Type	InspectorP64x Flex (V2D64xP-MCxxx) InspectorP65x Flex (V2D65xP-MCxxx)	InspectorP65x DynamicFocus (V2D65xP-MExxx)
Serial RS-232/ 422	Host (300 Bd ... 115.2 kBd), for data output	
Serial RS-232	Aux (57.6 kBd)	
USB	Not supported	
Ethernet	Image transmission (FTP). 10/100/1,000 Mbit/s, TCP/IP, PROFINET IO, EtherNet/IP. MAC address(es), see type label.	
CAN	20 kbit/s ... 1 Mbit/s Protocol: SICK CAN sensor network	
PROFIBUS <sup>1)</sup>	Optional via external fieldbus module CDF600-21xx	
PROFINET IO	Built-in, additionally available (optional) via external fieldbus module CDF600-2200	
Digital switching inputs and outputs	2 x Sensor 1 and 2 4 x physical (freely configurable inputs and outputs) 2 x additional external via optional CMC600 <sup>1)</sup> module in connection module CDB650-204 or CDM420-0006 (external input/output 1 and 2)	
Digital switching inputs	2 x Sensor 1 and 2 4 x physical (configurable IN 3 ... 6) U <sub>e</sub> = max. 32 V, I <sub>e</sub> = max. 5 mA, opto-decoupled, reverse polarity protected, adjustable debounce time	
Digital switching outputs	4 x physical (configurable OUT 3 ... 6) U <sub>a</sub> = U <sub>v</sub> - 1.5 V, I <sub>a</sub> ≤ 100 mA. Short-circuit protected, temperature protected. Not galvanically isolated from the supply voltage.	

<sup>1)</sup> Function planned

## 11.4 Mechanics and electronics

Type	InspectorP64x Flex (V2D64xP-MCxxx) InspectorP65x Flex (V2D65xP-MCxxx)	InspectorP65x DynamicFocus (V2D65xP-MExxx)
Optical indicators	10 x RGB LEDs: status indicators 1 x LED: feedback LED, green 10 x RGB LEDs: bar graph, blue	



Type	InspectorP64x Flex (V2D64xP-MCxxxx) InspectorP65x Flex (V2D65xP-MCxxxx)	InspectorP65x DynamicFocus (V2D65xP-MExxxx)
Acoustic indicators	1 x beeper for signaling events, can be deactivated	
External backup of configuration data	Optional on plug-in micro SD memory card or via optional CMC600 module in connection module CDB650-204 or CDM420-0006.	
Supply voltage	DC 24 V ± 20% SELV (EN 60950-1: 2014-08) and LPS (EN 60950-1: 2014-08) or Class 2 (UL 1310) required	
Current consumption	Max. 2.0 A (with switching outputs)	
Power consumption	Typically 20 W (with switching outputs without load)	
Weight	Max. 635 g, without optic kit	Max. 950 g, model-dependent
Material Housing	Aluminum die cast	
Material Viewing window	Glass or plastic (PMMA), 2 mm thick, with scratch-proof coating: <a href="#">see "Type code", page 12</a>	
Electrical protection class	III, in accordance with DIN EN 60950-1: 2014-08	
Enclosure rating	According to EN 60529: 2000-09: <a href="#">see "Type code", page 12</a> Maintaining the enclosure rating, <a href="#">see "Notes on electrical installation", page 28</a> .	

## 11.5 Ambient data

Type	InspectorP64x Flex (V2D64xP-MCxxxx) InspectorP65x Flex (V2D65xP-MCxxxx)	InspectorP65x DynamicFocus (V2D65xP-MExxxx)
Vibration resistance Shock resistance	According to EN 60068-2-6: 2008-02 In accordance with EN 60068-2-27: 2009-05	
Ambient temperature	Operation <sup>1)</sup> : 0 °C ... +50 °C Storage -20 °C ... +70 °C	
Permissible relative humidity	0% ... 90%, non-condensing	

<sup>1)</sup> Notes regarding adequate dissipation of lost heat: [see "Mounting requirements", page 18](#)

### 12 Accessories

---



**NOTE**

Accessories and where applicable mounting information can be found online at:

- [www.sick.com/InspectorP64x](http://www.sick.com/InspectorP64x)
  - [www.sick.com/InspectorP65x](http://www.sick.com/InspectorP65x)
-

## 13 Annex

### 13.1 EU declaration of conformity / Certificates

The EU declaration of conformity and other certificates can be downloaded from the Internet at:

- [www.sick.com/InspectorP64x](http://www.sick.com/InspectorP64x)
- [www.sick.com/InspectorP65x](http://www.sick.com/InspectorP65x)

### 13.2 Licenses

SICK uses open-source software. This software is licensed by the rights holders using the following licenses among others: the free licenses GNU General Public License (GPL Version2, GPL Version3) and GNU Lesser General Public License (LGPL), the MIT license, zLib license, and the licenses derived from the BSD license.

This program is provided for general use, but WITHOUT ANY WARRANTY OF ANY KIND. This warranty disclaimer also extends to the implicit assurance of marketability or suitability of the program for a particular purpose.

More details can be found in the GNU General Public License. View the complete license texts here: [www.sick.com/licensetexts](http://www.sick.com/licensetexts). Printed copies of the license texts are also available on request.

**Australia**

Phone +61 3 9457 0600  
1800 334 802 - tollfree  
E-Mail sales@sick.com.au

**Austria**

Phone +43 22 36 62 28 8-0  
E-Mail office@sick.at

**Belgium/Luxembourg**

Phone +32 2 466 55 66  
E-Mail info@sick.be

**Brazil**

Phone +55 11 3215-4900  
E-Mail marketing@sick.com.br

**Canada**

Phone +1 905 771 14 44  
E-Mail information@sick.com

**Czech Republic**

Phone +420 2 57 91 18 50  
E-Mail sick@sick.cz

**Chile**

Phone +56 2 2274 7430  
E-Mail info@schadler.com

**China**

Phone +86 20 2882 3600  
E-Mail info.china@sick.net.cn

**Denmark**

Phone +45 45 82 64 00  
E-Mail sick@sick.dk

**Finland**

Phone +358-9-2515 800  
E-Mail sick@sick.fi

**France**

Phone +33 1 64 62 35 00  
E-Mail info@sick.fr

**Germany**

Phone +49 211 5301-301  
E-Mail info@sick.de

**Hong Kong**

Phone +852 2153 6300  
E-Mail ghk@sick.com.hk

**Hungary**

Phone +36 1 371 2680  
E-Mail office@sick.hu

**India**

Phone +91 22 4033 8333  
E-Mail info@sick-india.com

**Israel**

Phone +972 4 6881000  
E-Mail info@sick-sensors.com

**Italy**

Phone +39 02 274341  
E-Mail info@sick.it

**Japan**

Phone +81 3 5309 2112  
E-Mail support@sick.jp

**Malaysia**

Phone +6 03 8080 7425  
E-Mail enquiry.my@sick.com

**Mexico**

Phone +52 472 748 9451  
E-Mail mario.garcia@sick.com

**Netherlands**

Phone +31 30 2044 000  
E-Mail info@sick.nl

**New Zealand**

Phone +64 9 415 0459  
0800 222 278 - tollfree  
E-Mail sales@sick.co.nz

**Norway**

Phone +47 67 81 50 00  
E-Mail sick@sick.no

**Poland**

Phone +48 22 539 41 00  
E-Mail info@sick.pl

**Romania**

Phone +40 356 171 120  
E-Mail office@sick.ro

**Russia**

Phone +7 495 775 05 30  
E-Mail info@sick.ru

**Singapore**

Phone +65 6744 3732  
E-Mail sales.gsg@sick.com

**Slovakia**

Phone +421 482 901201  
E-Mail mail@sick-sk.sk

**Slovenia**

Phone +386 591 788 49  
E-Mail office@sick.si

**South Africa**

Phone +27 11 472 3733  
E-Mail info@sickautomation.co.za

**South Korea**

Phone +82 2 786 6321  
E-Mail info@sickkorea.net

**Spain**

Phone +34 93 480 31 00  
E-Mail info@sick.es

**Sweden**

Phone +46 10 110 10 00  
E-Mail info@sick.se

**Switzerland**

Phone +41 41 619 29 39  
E-Mail contact@sick.ch

**Taiwan**

Phone +886 2 2375-6288  
E-Mail sales@sick.com.tw

**Thailand**

Phone +66 2645 0009  
E-Mail Ronnie.Lim@sick.com

**Turkey**

Phone +90 216 528 50 00  
E-Mail info@sick.com.tr

**United Arab Emirates**

Phone +971 4 88 65 878  
E-Mail info@sick.ae

**United Kingdom**

Phone +44 1727 831121  
E-Mail info@sick.co.uk

**USA**

Phone +1 800 325 7425  
E-Mail info@sick.com

**Vietnam**

Phone +84 945452999  
E-Mail Ngo.Duy.Linh@sick.com

Further locations at [www.sick.com](http://www.sick.com)