

MCS100FT
FTIR Multicomponent Analysis System
for Continuous Flue Gas Monitoring



- Installation
- Operation
- Maintenance



Document Information

Document ID

Title: Operating Instructions MCS100FT
Part No.: 8011893
Version: 2-1
Release: 2012-07

Product

Product name: MCS100FT

Manufacturer

SICK AG
Erwin-Sick-Str. 1 · 79183 Waldkirch · Germany
Tel.: +49 7641 469-0
Fax: +49 7641 469-11 49
E-Mail: info.pa@sick.de

Trademarks

Modbus is a trademark of Schneider Automation.
PROFIBUS a trademark of Profibus Nutzerorganisation e.V.
Other product names used in this document may also be trademarks and are only used for identification purposes.

Original documents

The English edition 8011893 of this document is an original document of the manufacturer.
SICK AG assumes no liability for the correctness of an unauthorized translation.
Contact the publisher in case of doubt.

Legal information

Subject to change without notice

© SICK AG. All rights reserved.

Glossary

a.u.: "arbitrary unit" (indefinite 2012-07 value).

CAN-Bus: Control Area Network. A field bus.

CompactFlash®-Disc: Memory card.

Ethernet: Computer networking technology. Basis for network protocols, e.g. TCP/IP.

ESD: Electrostatic Discharge

Field bus: An industrial communication system connecting a variety of field equipment such as analyzers, measuring sensors, actuators and drives with a control unit.

Firewall: Safety concept of software and hardware components to restrict access to computer networks.

Modbus®: Field bus communication protocol

PROFIBUS®: Field bus communication protocol

OLE: Object Linking and Embedding. Standardized data interface (Microsoft Corporation)

OPC: Openness, Productivity, Collaboration. Standardized data interface (OPC Foundation™).

Span gas: Test gas with a concentration of approx. 75% of the full scale limit.

SOPAS (SICK Open Portal for Applications and Systems): SICK Parameter Setting and Data Calculation Software.

SOPAS ET: SOPAS PC Engineering Tool. Configuration protocol.

TCP/IP: Network protocol.

Warning Symbols



Hazard (general)



Hazard by voltage



Hazard by explosive substances/mixtures



Hazard by corrosive substances



Hazard by unhealthy substances



Hazard by laser radiation

Warning Levels

DANGER

Immediate hazard which *will* result in severe personal injury or death.

WARNING

Risk or hazardous situation which *could* result in severe personal injury or death.

CAUTION

Hazard or unsafe practice which *could* result in personal injury or property damage.

Information Symbols



Important technical information for this product



Important information on electrical or electronic functions



Supplementary information



Link to information at another place



Nice to know

1	Important Information	7
1.1	Main hazards	8
1.2	Intended use	8
1.2.1	Purpose of the device	8
1.3	Responsibility of user	8
1.4	Additional documentation/information	9
2	Product Description	11
2.1	Product identification	12
2.2	Features of the MCS100FT	12
2.2.1	Method of operation	13
2.2.2	Internal functional units	13
2.3	Interfaces	14
2.4	Remote control	14
2.4.1	Ethernet	14
2.4.2	Modbus	14
2.4.3	OPC (option)	14
2.4.4	QAL3 (option)	14
2.5	Description of subassemblies	15
2.5.1	Exterior view	15
2.5.2	Interior view	16
2.5.3	Interferometer	16
2.5.4	O ₂ sensor	16
2.5.5	TOC with FID-100FT (option)	17
2.6	Gas flow plan	18
3	Preparations for Initial Start-up	19
3.1	Scope of delivery	20
3.2	Preparing the installation location	20
3.3	Transport and installation	21
3.4	Preparing the gas connections	21
3.4.1	Connecting the gas outlet	23
3.5	Preparing the electrical installation	24
3.6	Ethernet interface	25
3.6.1	Connection to a PC	26
3.6.2	Connection to a switch or a hub	26
3.7	Modbus	26
3.8	OPC (option)	26
4	Start-up	27
4.1	Persons authorized to carry out the start-up	28
4.2	Before switching on	28
4.3	Switching on the MCS100FT	29

5	Operation	31
5.1	Operator panel	32
5.2	Entering text	32
5.3	Time and date	32
5.4	Measuring screen	33
5.4.1	Status lines	33
5.5	Menu trees - what is where	35
5.5.1	Top menu level	35
5.5.2	SCU menu tree	36
5.5.3	MCS100FT menu tree	37
5.5.4	FID-100FT menu tree	38
5.6	“System Control Unit” (SCU) menus	39
5.6.1	Menu tree	39
5.6.2	Menu selection	39
5.6.3	Login (user levels)	39
5.6.4	Upload all Parameters from Device	39
5.6.5	Start screen	40
5.6.6	Measuring screen	40
5.6.7	Diagnosis	43
5.6.8	Parameter setting	45
5.6.9	Maintenance	45
5.7	MCS100FT menus	50
5.7.1	Menu tree	50
5.7.2	Menu selection	50
5.7.3	Login (user levels)	51
5.7.4	Upload all parameters from device	51
5.7.5	Measured values	52
5.7.6	Parameters	52
5.7.7	Adjustment	55
5.7.8	Diagnosis	61
5.7.9	Maintenance	69
5.8	FID-100FT menus (option)	70
5.8.1	Menu tree	70
5.8.2	Selection	70
5.8.3	Measured value	70
5.8.4	Language	71
5.8.5	Parameter	71
5.8.6	Adjustment	74
5.8.7	Diagnosis	75
5.8.8	Maintenance	79
5.9	Starting important operating sequences	81
5.9.1	Purge system with instrument air	81
5.9.2	Checking and adjusting with test gas	81
5.9.3	Checking without test gas (option)	81

6	Shutdown	83
6.1	Switching off (for a period up to approx. 2 weeks)	84
6.2	Shutting down	84
6.3	Transport	84
6.4	Storage	84
6.5	Disposal	85
7	Scheduled Maintenance	87
7.1	Maintenance intervals	88
7.1.1	Recommended spare parts for 2 years operation	88
7.2	Description of maintenance work	89
7.2.1	Visual control	89
7.2.2	Renewing the fan pad	89
7.2.3	Checking/replacing the drying agent cartridge in the interferometer	90
8	Clearing Malfunctions	93
8.1	Fuses	94
8.2	Faults on the monitor	94
8.3	Indicators on the operator panel	95
8.3.1	Status field red - "Stand-By"	95
8.3.2	"Current menu level" is red	95
8.3.3	Time / date displayed is incorrect	95
8.4	Malfunctions of the I/O modules	96
8.5	Checking the operating state of the interferometer	96
8.6	FID does not ignite/burn	96
9	Technical Documentation	97
9.1	Approvals	98
9.1.1	Conformity	98
9.1.2	Electrical protection	98
9.2	Dimensions	99
9.3	Technical data	100

MCS100FT

1 Important Information

Main hazards
Main instructions for operation
Intended use
Own responsibility

1.1 Main hazards

Overview of important safety information:



Moist instrument air damages the interferometer.

- ▶ Always follow the instrument air specification (→ p. 101).



WARNING: Risk of explosions on MCS100FT with FID-100FT

The FID-100FT is supplied with hydrogen. Risk of explosions due to leaky lines.

- ▶ Do not plug or block exhaust air openings (→ p. 20, §3.2).
- ▶ Do not operate the MCS100FT with FID-100FT in closed rooms
OR
install a hydrogen sensor (H₂ sensor) (< 25% LEL)

1.2 Intended use

1.2.1 Purpose of the device

The MCS100FT is a multicomponent analysis system for continuous flue gas monitoring of industrial combustion plants (emission measuring system).

The sample gas is extracted at the sampling point and fed through the analysis system (extractive measurement).

1.3 Responsibility of user

Designated users

The MCS100FT may be operated by competent persons only who, based on their device-specific training and knowledge of the device as well as knowledge of the relevant regulations, can assess the tasks given and recognize the dangers involved.

Correct use

- ▶ Only use the device as described in these Operating Instructions.
The manufacturer bears no responsibility for any other use.
- ▶ Perform the prescribed maintenance.
- ⊗ No components may be removed, added or changed on the device unless described and specified in the official manufacturer information. Otherwise:
 - The device could become dangerous.
 - Any warranty by the manufacturer becomes void.

Special local conditions

- ▶ In addition to these Operating Instructions, follow all local laws, technical rules and company-internal operating directives applicable at the respective installation location of the device.

Retention of documents

These Operating Instructions and the System Documentation:

- ▶ Must be available for reference.
- ▶ Must be passed on to new owners.

1.4

Additional documentation/information

The following documents are applicable in addition to these Operating Instructions:

Instructions delivered with the System Documentation

- SCU Operating Instructions
- SCU Technical Information
- Modular I/O System Operating Instructions
- Heater Controller (HC8X) Operating Instructions
- Documentation on individual settings
- Installation Plan

Additional instructions (optional)

- Gas Sampling Probe Operating Instructions
- Instrument Air Conditioning System Operating Instructions

MCS100FT

2 Product Description

Device features
Functional principle
Device description

2.1 Product identification

Type plate

The *type plate* is located on the top of the right cabinet side.



It is possible that your MCS100FT has a different configuration to that described in this manual.

- ▶ Refer to the System Documentation (→ p. 9, § 1.4) delivered with your MCS100FT for the individual configuration of your system.

2.2 Features of the MCS100FT

Fig. 1

Extractive measuring system MCS100FT (components only examples)

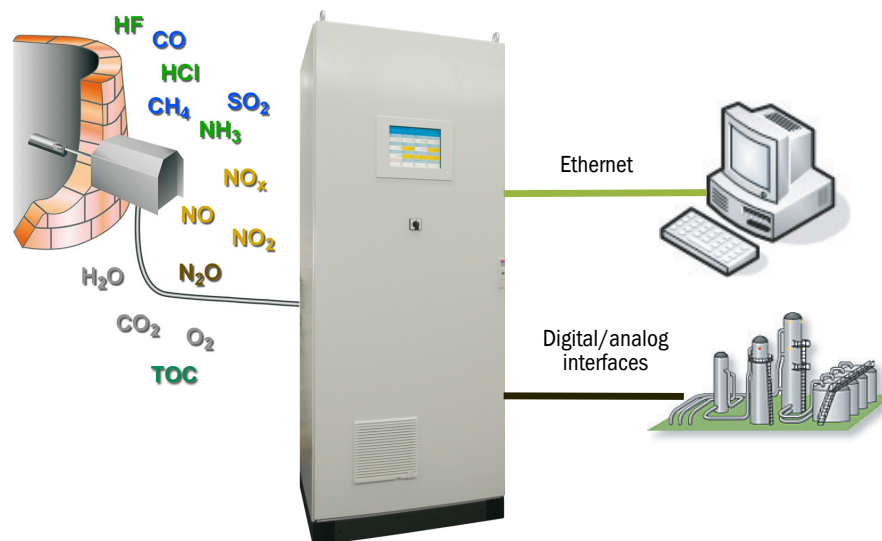

The MCS100FT is a multicomponent analysis system for continuous flue gas monitoring of industrial combustion plants (*emission measuring system*).

The MCS100FT operates in extractive mode, i.e. the gas is withdrawn from the gas duct using a gas sampling probe and fed to the analysis system via a (heated) sample gas line.

The acquired measured values are computed internally (cross-sensitivity compensation, scaling (pressure, temperature), conversion to “dry flue gas” etc.).

2.2.1 Method of operation

The MCS100FT operates independently.

- Sampling probe backflush and test gas feed are performed cyclically and can also be started manually.
- The MCS100FT signals an *uncertain operating state* with status indicators (→ p. 33, §5.4.1). The MCS100FT remains in Measuring mode.
- Should a *malfunction* occur, the MCS100FT switches automatically to “Stand-by” mode (→ p. 95, §8.3.1). The sample gas line and the sample gas path in the MCS100FT are automatically purged with instrument air in this mode.
The analog outputs remain at the last valid measured value.

The operational states are signaled by status signals and entered in a logbook.

2.2.2 Internal functional units

The MCS100FT contains the following independent functional units:

- The MCS100FT analyzer (with Fourier Transform Infrared spectrometer (FTIR spectrometer) and O₂ sensor).
- The FID-100FT (analyzer) (option).
- The System Control Unit (SCU) that manages the MCS100FT analyzer and (optionally) the FID-100FT analyzer and contains the operator panel.

All functional units are independent and have their own menu structure on the operator panel with own parameter settings, own password levels, own logbook, etc.

Functions of the MCS100FT analyzer

- The MCS100FT analyzer records measured values and cross-sensitivities.
It calculates the sample gas concentrations on a scaled (pressure, temperature) basis.
- Menu item “MCS100FT” (→ p. 37, §5.5.3) serves to view, and set parameters (password protected), for the MCS100FT analyzer settings on the operator panel.

FID-100FT (option) functions

- The FID-100FT analyzer records measured values (uncorrected raw values).
- Menu item “FID/100FT” (→ p. 38, §5.5.4) serves to view, and set parameters (password protected), for the FID-100FT analyzer settings.

Functions of the System Control Unit (SCU)

- As higher level control unit, the SCU itself provides the operator panel to operate the MCS100FT, the FID-100FT (option) and the SCU.
- The SCU reads the scaled MCS100FT analyzer measured values and the FID-100FT (option) measured values, and performs conversions (e.g.: Conversion to dry flue gas), averaging, etc.
- The SCU contains the programs (formulas) that control the sequences (e.g. zero cycle) of the MCS100FT analyzer and the FID-100FT.
- The settings of the SCU and the measured values calculated by the SCU can be viewed and set (with password protection) using the “System Control Unit” menu item (→ p. 36, §5.5.2).

2.3 Interfaces

Standard: Analog and digital interfaces.

Option: RS485/422 (Modbus RTU) (→ SCU Operating Instructions).

2.4 Remote control

2.4.1 Ethernet

Standard: Ethernet (Modbus TCP/IP).

Operation via SOPAS ET (option)

Operator menus and Measuring screens are also available on an external PC via Ethernet for user comfort (with the engineering tool SOPAS ET → “SCU” Operating Instructions).

2.4.2 Modbus

Modbus® is a communication standard for digital controls to connect a »Master« device with several »Slave« devices. The Modbus protocol defines the communication commands only but not their electronic transfer; therefore it can be used with different digital interfaces (for MCS100FT: Ethernet).



Further information on the Modbus:

- Parameter settings → SCU Operating Instructions
- Further information: → “SCU Technical Information” manual

2.4.3 OPC (option)

OPC is a standardized software interface that allows to exchange data between the applications of different manufacturers.

The SICK OPC server is required.

System bus: Ethernet.



Further information on the OPC:

- Parameter settings → SCU Operating Instructions
- Further information: → “SCU Technical Information” manual

2.4.4 QAL3 (option)

Optional QAL3 quality monitoring according to DIN EN 14181 with internal adjustment standard (filter wheel) or span gas.

Monitoring can be triggered manually or cyclically.

2.5 Description of subassemblies

2.5.1 Exterior view

Fig. 2 Front view

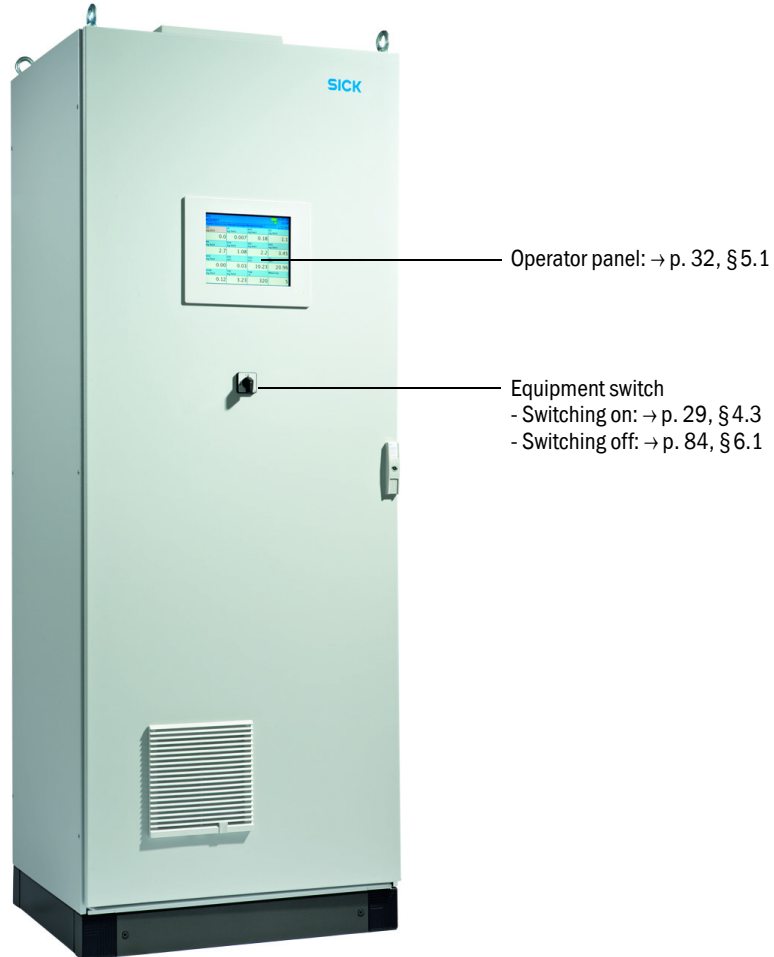

2.5.2 Interior view

Fig. 3 Interior view-

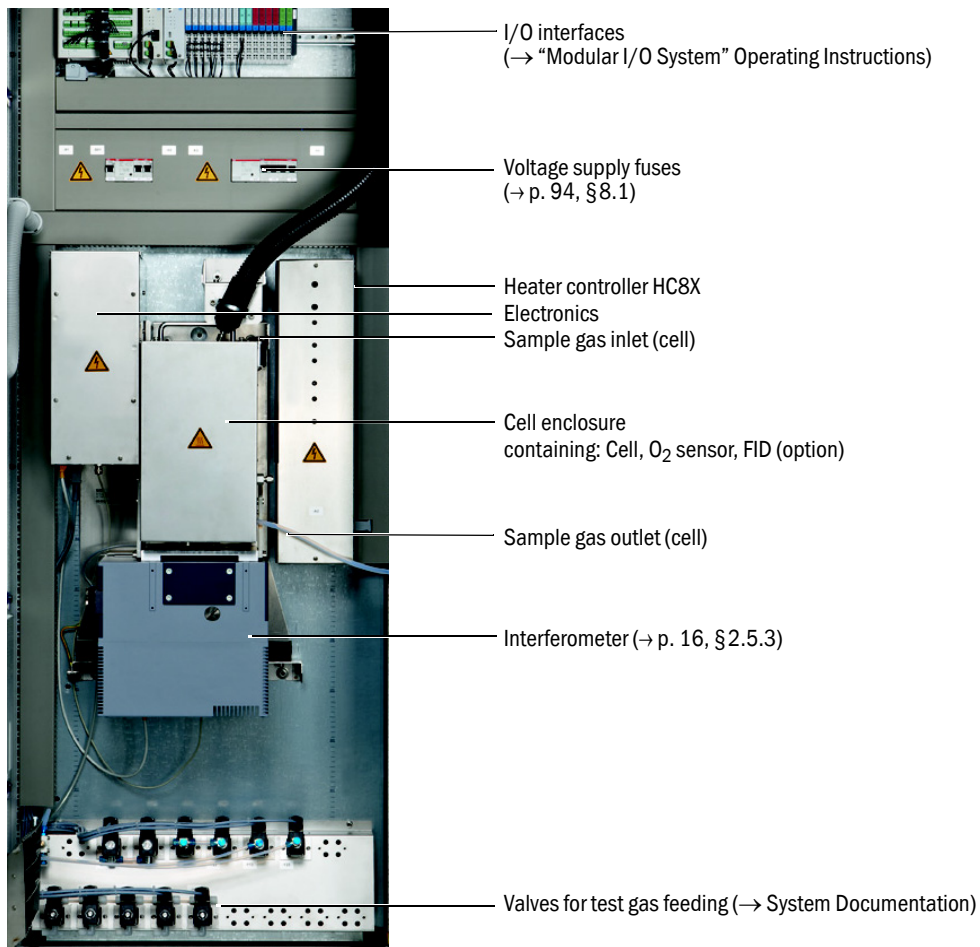

2.5.3 Interferometer

The interferometer in the MCS100FT contains a laser.

The interferometer complies with *laser class 1*.



WARNING: Laser radiation inside the interferometer

The laser radiation (*laser class 3R*) *inside* the interferometer can cause permanent damage to the eyes.

- ⊗ Do not open any part of the interferometer enclosure or look into the laser beam or its reflection directly or by using optical instruments.

2.5.4 O₂ sensor

Oxygen measurement is performed with a zirconium dioxide (ZrO₂) sensor (in short: O₂ sensor).

The O₂ sensor is located within the cell enclosure.

The signals of the O₂ sensor are integrated in MCS100FT signal processing.

2.5.5

TOC with FID-100FT (option)

As an option, the MCS100FT can be fitted with a FID (Flame Ionization Detector) to measure the organically bound total carbon (TOC).

The FID is located in the cell enclosure.

The signals of the FID-100FTs are integrated in MCS100FT signal processing.

The measured values are displayed on the operator panel.

2.6 Gas flow plan

Fig. 4 Gas flow plan

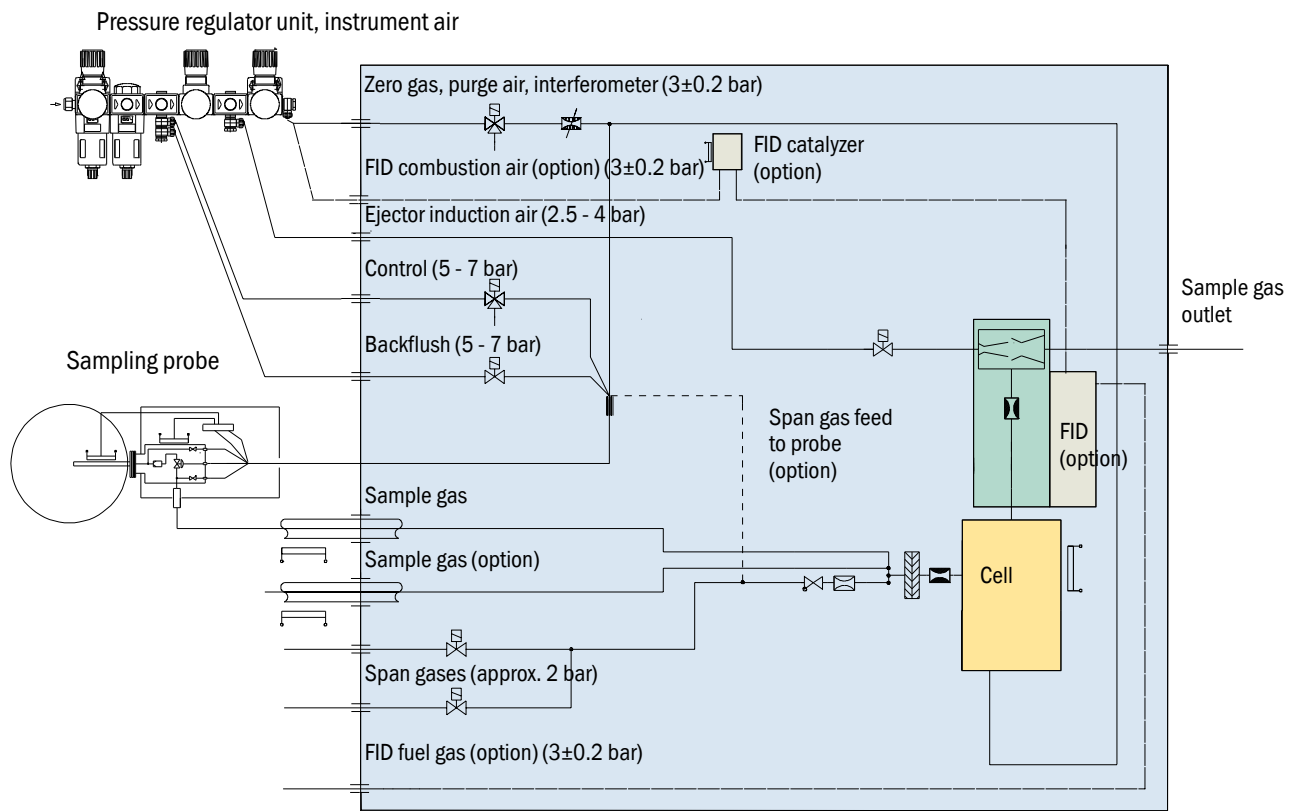

MCS100FT

3 Preparations for Initial Start-up

Installation
Assembly

3.1 Scope of delivery

Please see the delivery documents for the scope of delivery.

3.2 Preparing the installation location



- ▶ The connection to the gas supply may only be performed by skilled persons who, based on their technical training and knowledge as well as knowledge of the relevant regulations, can assess the tasks given and recognize the hazards involved.
- ▶ Also follow all local laws, technical rules and company-internal operating directives applicable at the respective installation location of the device.

The persons performing the installation are responsible for the preparation of the installation location.

- Take the ambient conditions (→ p. 101) into account.
- Enclosure dimensions → p. 99, §9.2
- Ensure the load carrying capacity of the floor is adequate (minimum 550 kg/m²).
- Set up the MCS100FT in a low-vibration environment whenever possible.
- Set up the MCS100FT as close as possible to the sampling point.
Short sample gas lines result in short lag times.
Maximum length of sample gas line: 35 m.
- Provide a suitable installation location for the test gas cylinders.
Note: Observe local regulations for the installation of gas cylinders.
- Provide a suitable installation location for the pressure regulator unit and (optionally) the instrument air conditioning system.
- Air outlet:



WARNING: Risk of explosions on MCS100FT with FID-100FT

The FID-100FT is supplied with hydrogen. Risk of explosions due to leaky lines.

- ▶ Do not plug or block the air outlet.
- ▶ Do not operate the MCS100FT with FID-100FT in closed rooms
OR
install a hydrogen sensor (H₂ sensor) (< 25% LEL)

- The air outlet is located in the MCS100FT lid.
- In the "IP54" version (option), the air outlet is on the right enclosure side.
- ▶ Do not block the air outlet.
 - Leave at least 20 cm clearance.
- Provide (individual) attachments for the system cabinet.
 - For installation on gratings: Parts could drop or liquids (e.g. condensate) could drip and cause injuries.
Provide a suitable base plate.

3.3

Transport and installation



The MCS100FT may only be transported and installed by skilled persons who, based on their training and knowledge as well as knowledge of the relevant regulations, can assess the tasks given and recognize the dangers involved.

- ▶ Position the MCS100FT with suitable hoisting equipment (for example a crane) (weight of the MCS100FT approx. 260 kg).
Use the lugs on the top cover.
- ▶ Secure the MCS100FT immediately against falling over.

3.4

Preparing the gas connections



WARNING: Hazards by leaky gas path

- Health risk when noxious sample gas leaks out.
- Risk of damage to the MCS100FT and adjacent equipment if the sample gas is corrosive or could generate corrosive liquids in combination with water (e.g. humidity).
- The measured values could possibly be incorrect if the gas path is leaky.
- ▶ The gas lines to the MCS100FT may only be laid by skilled persons who, based on their training and knowledge as well as knowledge of the relevant regulations, can assess the tasks given and recognize the dangers involved.
- ▶ The connection of the gas lines to the MCS100FT may only be performed by SICK Customer Service.



CAUTION: Risk of explosion when explosive sample gas is used

- ▶ Do not use the MCS100FT for measuring explosive or combustible gases



Moist instrument air damages the interferometer.

- ▶ Always follow the instrument air specification (→ p. 101).



For MCS100FT with FID-100FT:

- ▶ Fit a pressure controller to the fuel gas pressure cylinder.
Signal output, for example, at 10 bar residual pressure (option).
- ▶ Provide an external stopcock on the system cabinet inlet for H₂ supply.
- ▶ Use a leak detector to check the H₂ supply leak tightness.

Fig. 5

Gas connections on the side and top

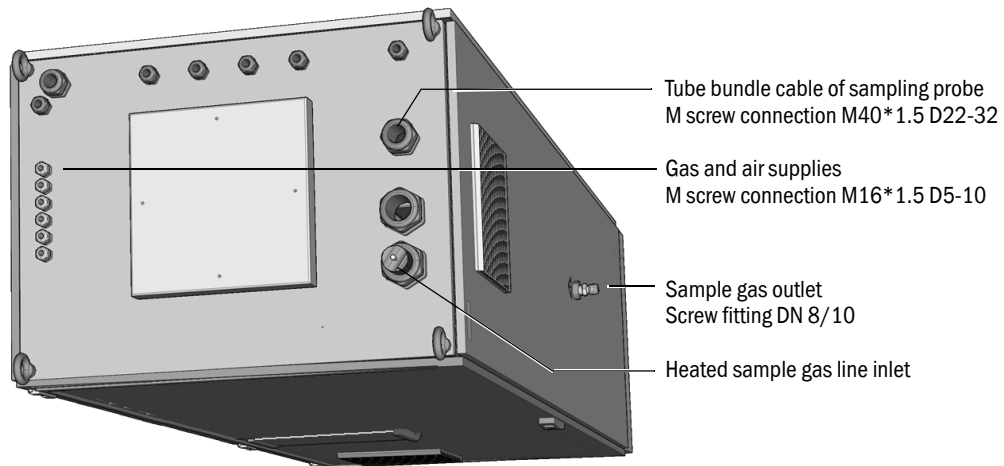

- 1 Lay the sample gas line from the sampling probe to the MCS100FT.



► Observe the information concerning laying sample gas lines enclosed with the sample gas lines.

- Direction: Electric connection on cabinet side.
- Leave excess length of the sample gas line on the sampling probe.

- 2 Lay the tube bundle cable from the sampling probe to the MCS100FT.
Direction: Any.
- 3 Provide instrument air supply (specification → p. 100, §9.3 and following), plan an instrument air conditioning system when necessary.
- 4 Lay gas lines for test gases. Make sure tubes are clean.



WARNING: Risk of explosions on MCS100FT with FID-100FT

The screw fitting (location depends on application) for hydrogen supply includes a flow limiter.

- The hydrogen inlet has a sticker marked "H₂".
- Do not modify this screw fitting.
- Do not connect the hydrogen supply to any other screw fitting.

- 5 For MCS100FT with FID-100FT:
 - Only use analytically pure tubes made of copper or stainless steel for the hydrogen supply.
 - Do not contaminate the insides of tubes during assembly

3.4.1

Connecting the gas outlet



CAUTION: Noxious and aggressive exhaust gases.

Exhaust gases can contain components harmful to health or irritating.

- ▶ Lead the measuring system gas outlets outdoors or into a suitable flue.
- ▶ Do not connect the exhaust gas line with the exhaust gas line of sensitive subassemblies (e.g. cooler). Aggressive gases could damage these subassemblies as a result of diffusions.
- ▶ Observe information from the plant operator.



Lay the exhaust gas line in a suitable manner.

- ▶ The gas outlet must be open to the ambient pressure; in waste disposal lines it can be laid with a light partial vacuum.
- ▶ Do not bend or crimp exhaust gas lines.



Condensate could accrue in the exhaust gas line.

- ▶ Use a suitable hose line (PTFE) to run the condensate outlet into an open condensate container or a waste disposal line.
- ▶ Lay the line so that it always runs downwards.
- ▶ Keep the line opening free from any blockages or liquids.
- ▶ Protect the line from frost.

- ▶ Connect the tube to the gas outlet.

3.5

Preparing the electrical installation**WARNING: Health risk by voltage**

- ▶ The preparation of the MCS100FT may only be performed by skilled electricians who, based on their technical training and knowledge as well as knowledge of the relevant regulations, can assess the tasks given and recognize the hazards involved.
- ▶ The wiring system to the power source of the system must be installed and fused according to the relevant regulations.



- ▶ Do not connect any electrical signals to the MCS100FT.
Let SICK Customer Service connect the MCS100FT electrics.

Fig. 6

Electrical connections in the cover of the MCS100FT

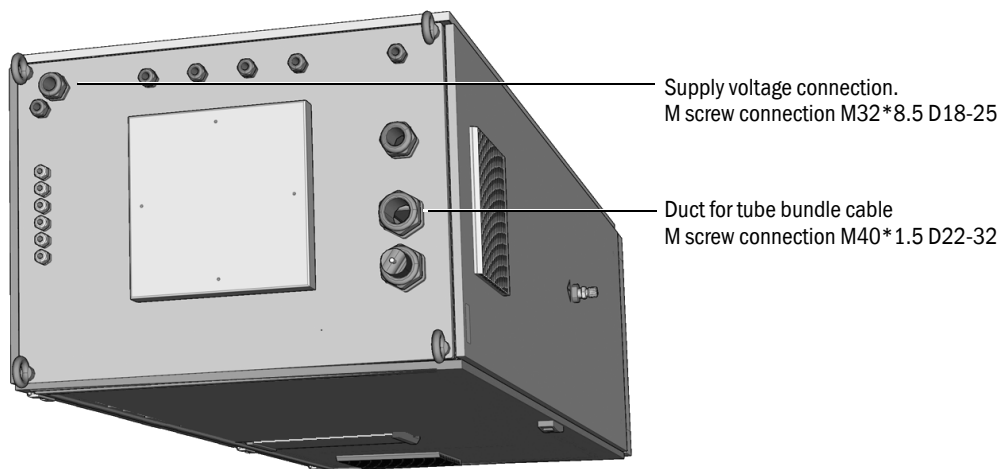

- 1 Lay the signal lines.
- 2 Lay the tube bundle cable of the sampling probe.
- 3 Provide the mains supply voltage.
Power input → »Technical data«.
Plan suitable mains supply separation.

3.6 Ethernet interface



When the MCS100FT is operated using Ethernet, there is the risk of undesired access to the MCS100FT via the Ethernet (“hacking”).

▶ Only operate the MCS100FT with firewall protection.

Fig. 7 Ethernet port on the rear of the operator panel

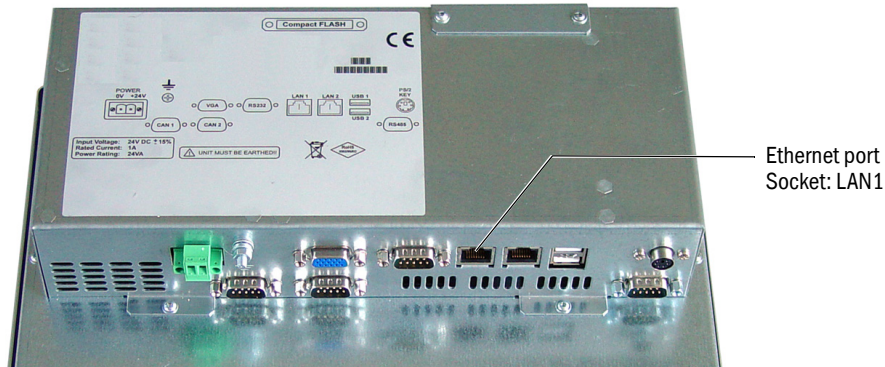

Let SICK Customer Service connect the Ethernet cable in the system cabinet of the MCS100FT.

- Plug: RJ 45
- Type: TCP/IP peer-to-peer
- Transmission parameter: 10 Mbit/s half-duplex
- Addresses (The IP address must be unique):
 - IP address of the SCU: See label at the Ethernet port.
 - IP addresses and the addresses of the SCU and MCS100FT subnet masks: See SOPAS ET (→ p. 14, §2.4.1).

To change addresses:

(Note: The unit (MCS100FT, FID-100FT or SCU) and the PC to be connected must be in the same network segment)

- a) Start SOPAS ET.
- b) “Network Scan Assistant”.
- c) “Network Configuration”.
- d) “Auto IP configuration” (“Enable AutoIP” must be clicked).
- e) “Search”.
- f) Click the desired device.
- g) “Edit”.

3.6.1 Connection to a PC

Fig. 8 MCS100FT with PC via Ethernet



- Cable: Crossover

Procedure

- ▶ Connect the Ethernet line.

3.6.2 Connection to a switch or a hub

Fig. 9 MCS100FT at the hub

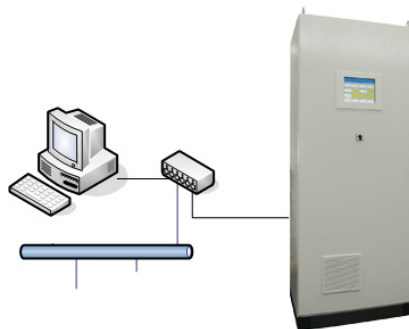

A PC and a user interface can be simultaneously connected to the SCU using a switch (multiconnect) or hub.

- Slot at the switch: Optional.
- Cable: 1:1 (no crossover).
Crossover cable possible, depending on switch or hub.

Procedure

- ▶ Connect the Ethernet line.

3.7 Modbus



For information on Modbus parameter settings: → "SCU" Operating Instructions

3.8 OPC (option)

Let SICK Customer Service install the OPC software.

MCS100FT

4 Start-up

Switching on
Assessment of error-free function

4.1 Persons authorized to carry out the start-up



The MCS100FT may only be put into operation by skilled persons who, based on their device-specific training and knowledge of the device as well as knowledge of the relevant regulations, can assess the tasks given and recognize the dangers involved.

4.2 Before switching on...



WARNING: Risk of explosions on MCS100FT with FID-100FT

▶ Before switching the mains voltage on, check: The H₂ concentration in the system cabinet must be < 25% LEL.

- ▶ Check: Is the MCS100FT dry and clean inside?
- ▶ Check: Is the drying agent cartridge of the interferometer dry (→ p. 90, § 7.2.3)?
- ▶ For MCS100FT with FID-100FT:
 - Check with a leak detector: Are the external hydrogen supply and the hydrogen connection on the system cabinet gas-tight.
 - Is the system cabinet ventilation ensured (exhaust air openings in system cabinet cover open).
 - If an H₂ sensor is fitted: Check the H₂ sensor functions correctly.
- ▶ Switch on all fuses (→ p. 94, § 8.1).

After a longer period of standstill (several weeks), also check:

- ▶ Instrument air supply and fuel gas supply (for FID-100FT) available and clean?



Moist or contaminated instrument air causes damage in the interferometer.

▶ Always follow the instrument air specification (→ p. 101).

- ▶ Test gases: Use-by date.
- ▶ Gas pressures.
- ▶ Sample gas outlet free from any blockages?
- ▶ Sampling probe ready for operation?
- ▶ For MCS100FT with FID-100FT: Leak tightness of the H₂ supply.

4.3

Switching on the MCS100FT

- 1 Switch the MCS100FT on with the device switch (→ p. 15, §2.5.1) (position “ON”).
- 2 The SICK logo appears after a few seconds.
- 3 The *green* “POWER” LED goes on after a few seconds.
- 4 A brown progress bar is displayed.
- 5 The monitor switches off for a few seconds.
- 6 A blue progress bar, a gray status bar and a clock symbol with rotating segments are displayed.
This process takes a few minutes (depending on the number and type of analyzers connected).

Fig. 10

Operator panel



- 7 The Start screen with the Measuring screen is shown.→ p. 33, §5.4
(Start screen default: → p. 40, §5.6.6.)

Fig. 11

Measuring screen (example)

SCU MCS100FT				25.05.10 14:01
Component Unit	Unit/Measuring/Measuring Screen 1	Component Unit	Component Unit	NN a.u.
701	17.3	126		NN a.u.
NN a.u.	NN a.u.	NN a.u.		NN a.u.
NN a.u.	NN a.u.	NN a.u.		NN a.u.
NN a.u.	NN a.u.	NN a.u.	Measuring	
				5

- 8 The MCS100FT is in Measuring mode when both status fields (→ p. 33, §5.4.1) are green.



Operation of the MCS100FT → p. 31, §5



If the system does *not* switch to Measuring mode:
Error message, see menu MCS100FT/Diagnosis/Logbook (→ p. 62, §5.7.8.2).

MCS100FT

5 Operation

Operation
Status messages

5.1 Operator panel

The MCS100FT is operated via a touchscreen where you can perform inputs by touching the monitor.



Operation via SOPAS ET (option)

Operator menus and Measuring screens are also available on an external PC via Ethernet for user comfort (with the engineering tool SOPAS ET → SCU Operating Instructions).

5.2 Entering text

If you touch a line which requires text input: A virtual keyboard for entering text is displayed:

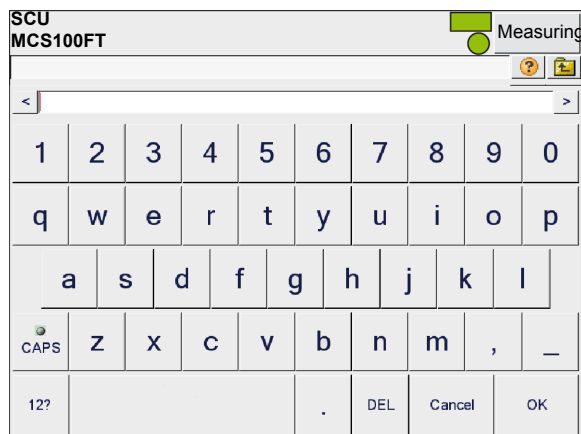

- “CAPS” key: Toggles between upper and lower case characters.
 - “CAPS” LED is on: Upper case is switched on.
- “12?” key: Toggle to numeric pad and special characters



You can also enter text via SOPAS ET (p. 32, §5.1).

5.3 Time and date



Setting the operator panel time and date:

Menu: *System Control Unit/Parameter/Device*: → “SCU Operating Instructions” and “SCU Technical Information” manuals.

MCS100FT and FID-100FT automatically retrieve date and time from the SCU.

5.4 Measuring screen

Typical Measuring screen:

2 status lines → p. 33, § 5.4.1

Current menu level

Measured value box → p. 41, § 5.6.6.1
Highlighted *light brown*:
The corresponding analyzer is shown in the second status line

Status fields (→ p. 33, § 5.4.1)

Date (dd.mm.yy) and time of the operator panel (→ § 5.4.1)

Switch to higher menu level.
The “Measure” field is displayed instead of Date and Time:

Touch “Measure” to return to the Measuring screen.

MCS100FT operating state with state code (only internal significance)

- ▶ To exit the menu: Touch
- Adjustment of Measuring screen → p. 40, § 5.6.6

5.4.1 Status lines

The SCU has 2 status lines:

- First status line: SCU status line (higher level control unit).
- Second status line: Status line of the analyzer currently selected (MCS100FT or FID-100FT)

The status lines have status fields (depending on parameter settings) to display the respective device status.

SCU status line
(Parameter settings → “SCU Technical Information” manual)

Status line of the analyzer
(MCS100FT or FID-100FT) for which the measured value box
(→ p. 41, § 5.6.6.1) is activated
(highlighted *light brown*).

Status fields
Top: SCU status field
Bottom: Analyzer status field

Significance of status fields

Abbrev.	Color	Significance	Cause
None	Green	Proper operation	---
MReq, M	Yellow	Maintenance request	A device function will shortly be restricted.
C		Functional check	Device-internal functional check running.
U		Uncertain	Uncertain device state.
F	Red	Failure	Failure.

The screenshot shows the SCU MCS100FT interface. At the top, there are status fields: 'F' (Failure), 'MReq' (Maintenance Request), 'C' (Control), and 'U' (Uncertain). Below these are four colored circles: red (F), yellow (M), green (C), and yellow (U). The top right shows the date and time: 25.05.10 14:01. The main display area is a table with columns for Component Unit and Measuring Unit. The first row shows values 701, 17.3, and 126. The second row shows 'NN a.u.' for all columns. The third row shows 'NN a.u.' for all columns. The fourth row shows 'NN a.u.' for all columns. The fifth row shows 'NN a.u.' for all columns. The sixth row shows 'NN a.u.' for all columns. The seventh row shows 'NN a.u.' for all columns. The eighth row shows 'NN a.u.' for all columns. The ninth row shows 'NN a.u.' for all columns. The tenth row shows 'NN a.u.' for all columns. The eleventh row shows 'NN a.u.' for all columns. The twelfth row shows 'NN a.u.' for all columns. The thirteenth row shows 'NN a.u.' for all columns. The fourteenth row shows 'NN a.u.' for all columns. The fifteenth row shows 'NN a.u.' for all columns. The sixteenth row shows 'NN a.u.' for all columns. The seventeenth row shows 'NN a.u.' for all columns. The eighteenth row shows 'NN a.u.' for all columns. The nineteenth row shows 'NN a.u.' for all columns. The twentieth row shows 'NN a.u.' for all columns. The twenty-first row shows 'NN a.u.' for all columns. The twenty-second row shows 'NN a.u.' for all columns. The twenty-third row shows 'NN a.u.' for all columns. The twenty-fourth row shows 'NN a.u.' for all columns. The twenty-fifth row shows 'NN a.u.' for all columns. The twenty-sixth row shows 'NN a.u.' for all columns. The twenty-seventh row shows 'NN a.u.' for all columns. The twenty-eighth row shows 'NN a.u.' for all columns. The twenty-ninth row shows 'NN a.u.' for all columns. The thirtieth row shows 'NN a.u.' for all columns. The thirty-first row shows 'NN a.u.' for all columns. The thirty-second row shows 'NN a.u.' for all columns. The thirty-third row shows 'NN a.u.' for all columns. The thirty-fourth row shows 'NN a.u.' for all columns. The thirty-fifth row shows 'NN a.u.' for all columns. The thirty-sixth row shows 'NN a.u.' for all columns. The thirty-seventh row shows 'NN a.u.' for all columns. The thirty-eighth row shows 'NN a.u.' for all columns. The thirty-ninth row shows 'NN a.u.' for all columns. The fortieth row shows 'NN a.u.' for all columns. The forty-first row shows 'NN a.u.' for all columns. The forty-second row shows 'NN a.u.' for all columns. The forty-third row shows 'NN a.u.' for all columns. The forty-fourth row shows 'NN a.u.' for all columns. The forty-fifth row shows 'NN a.u.' for all columns. The forty-sixth row shows 'NN a.u.' for all columns. The forty-seventh row shows 'NN a.u.' for all columns. The forty-eighth row shows 'NN a.u.' for all columns. The forty-ninth row shows 'NN a.u.' for all columns. The fiftieth row shows 'NN a.u.' for all columns. The fifty-first row shows 'NN a.u.' for all columns. The fifty-second row shows 'NN a.u.' for all columns. The fifty-third row shows 'NN a.u.' for all columns. The fifty-fourth row shows 'NN a.u.' for all columns. The fifty-fifth row shows 'NN a.u.' for all columns. The fifty-sixth row shows 'NN a.u.' for all columns. The fifty-seventh row shows 'NN a.u.' for all columns. The fifty-eighth row shows 'NN a.u.' for all columns. The fifty-ninth row shows 'NN a.u.' for all columns. The sixtieth row shows 'NN a.u.' for all columns. The sixty-first row shows 'NN a.u.' for all columns. The sixty-second row shows 'NN a.u.' for all columns. The sixty-third row shows 'NN a.u.' for all columns. The sixty-fourth row shows 'NN a.u.' for all columns. The sixty-fifth row shows 'NN a.u.' for all columns. The sixty-sixth row shows 'NN a.u.' for all columns. The sixty-seventh row shows 'NN a.u.' for all columns. The sixty-eighth row shows 'NN a.u.' for all columns. The sixty-ninth row shows 'NN a.u.' for all columns. The seventieth row shows 'NN a.u.' for all columns. The seventy-first row shows 'NN a.u.' for all columns. The seventy-second row shows 'NN a.u.' for all columns. The seventy-third row shows 'NN a.u.' for all columns. The seventy-fourth row shows 'NN a.u.' for all columns. The seventy-fifth row shows 'NN a.u.' for all columns. The seventy-sixth row shows 'NN a.u.' for all columns. The seventy-seventh row shows 'NN a.u.' for all columns. The seventy-eighth row shows 'NN a.u.' for all columns. The seventy-ninth row shows 'NN a.u.' for all columns. The eightieth row shows 'NN a.u.' for all columns. The eighty-first row shows 'NN a.u.' for all columns. The eighty-second row shows 'NN a.u.' for all columns. The eighty-third row shows 'NN a.u.' for all columns. The eighty-fourth row shows 'NN a.u.' for all columns. The eighty-fifth row shows 'NN a.u.' for all columns. The eighty-sixth row shows 'NN a.u.' for all columns. The eighty-seventh row shows 'NN a.u.' for all columns. The eighty-eighth row shows 'NN a.u.' for all columns. The eighty-ninth row shows 'NN a.u.' for all columns. The ninetieth row shows 'NN a.u.' for all columns. The hundredth row shows 'NN a.u.' for all columns. The hundred and first row shows 'NN a.u.' for all columns. The hundred and second row shows 'NN a.u.' for all columns. The hundred and third row shows 'NN a.u.' for all columns. The hundred and fourth row shows 'NN a.u.' for all columns. The hundred and fifth row shows 'NN a.u.' for all columns. The hundred and sixth row shows 'NN a.u.' for all columns. The hundred and seventh row shows 'NN a.u.' for all columns. The hundred and eighth row shows 'NN a.u.' for all columns. The hundred and ninth row shows 'NN a.u.' for all columns. The hundred and tenth row shows 'NN a.u.' for all columns. The hundred and eleventh row shows 'NN a.u.' for all columns. The hundred and twelfth row shows 'NN a.u.' for all columns. The hundred and thirteenth row shows 'NN a.u.' for all columns. The hundred and fourteenth row shows 'NN a.u.' for all columns. The hundred and fifteenth row shows 'NN a.u.' for all columns. The hundred and sixteenth row shows 'NN a.u.' for all columns. The hundred and seventeenth row shows 'NN a.u.' for all columns. The hundred and eighteenth row shows 'NN a.u.' for all columns. The hundred and nineteenth row shows 'NN a.u.' for all columns. The hundred and twentieth row shows 'NN a.u.' for all columns. The hundred and twenty-first row shows 'NN a.u.' for all columns. The hundred and twenty-second row shows 'NN a.u.' for all columns. The hundred and twenty-third row shows 'NN a.u.' for all columns. The hundred and twenty-fourth row shows 'NN a.u.' for all columns. The hundred and twenty-fifth row shows 'NN a.u.' for all columns. The hundred and twenty-sixth row shows 'NN a.u.' for all columns. The hundred and twenty-seventh row shows 'NN a.u.' for all columns. The hundred and twenty-eighth row shows 'NN a.u.' for all columns. The hundred and twenty-ninth row shows 'NN a.u.' for all columns. The hundred and thirtieth row shows 'NN a.u.' for all columns. The hundred and thirty-first row shows 'NN a.u.' for all columns. The hundred and thirty-second row shows 'NN a.u.' for all columns. The hundred and thirty-third row shows 'NN a.u.' for all columns. The hundred and thirty-fourth row shows 'NN a.u.' for all columns. The hundred and thirty-fifth row shows 'NN a.u.' for all columns. The hundred and thirty-sixth row shows 'NN a.u.' for all columns. The hundred and thirty-seventh row shows 'NN a.u.' for all columns. The hundred and thirty-eighth row shows 'NN a.u.' for all columns. The hundred and thirty-ninth row shows 'NN a.u.' for all columns. The hundred and fortieth row shows 'NN a.u.' for all columns. The hundred and forty-first row shows 'NN a.u.' for all columns. The hundred and forty-second row shows 'NN a.u.' for all columns. The hundred and forty-third row shows 'NN a.u.' for all columns. The hundred and forty-fourth row shows 'NN a.u.' for all columns. The hundred and forty-fifth row shows 'NN a.u.' for all columns. The hundred and forty-sixth row shows 'NN a.u.' for all columns. The hundred and forty-seventh row shows 'NN a.u.' for all columns. The hundred and forty-eighth row shows 'NN a.u.' for all columns. The hundred and forty-ninth row shows 'NN a.u.' for all columns. The hundred and fiftieth row shows 'NN a.u.' for all columns. The hundred and fifty-first row shows 'NN a.u.' for all columns. The hundred and fifty-second row shows 'NN a.u.' for all columns. The hundred and fifty-third row shows 'NN a.u.' for all columns. The hundred and fifty-fourth row shows 'NN a.u.' for all columns. The hundred and fifty-fifth row shows 'NN a.u.' for all columns. The hundred and fifty-sixth row shows 'NN a.u.' for all columns. The hundred and fifty-seventh row shows 'NN a.u.' for all columns. The hundred and fifty-eighth row shows 'NN a.u.' for all columns. The hundred and fifty-ninth row shows 'NN a.u.' for all columns. The hundred and sixtieth row shows 'NN a.u.' for all columns. The hundred and sixty-first row shows 'NN a.u.' for all columns. The hundred and sixty-second row shows 'NN a.u.' for all columns. The hundred and sixty-third row shows 'NN a.u.' for all columns. The hundred and sixty-fourth row shows 'NN a.u.' for all columns. The hundred and sixty-fifth row shows 'NN a.u.' for all columns. The hundred and sixty-sixth row shows 'NN a.u.' for all columns. The hundred and sixty-seventh row shows 'NN a.u.' for all columns. The hundred and sixty-eighth row shows 'NN a.u.' for all columns. The hundred and sixty-ninth row shows 'NN a.u.' for all columns. The hundred and seventieth row shows 'NN a.u.' for all columns. The hundred and seventy-first row shows 'NN a.u.' for all columns. The hundred and seventy-second row shows 'NN a.u.' for all columns. The hundred and seventy-third row shows 'NN a.u.' for all columns. The hundred and seventy-fourth row shows 'NN a.u.' for all columns. The hundred and seventy-fifth row shows 'NN a.u.' for all columns. The hundred and seventy-sixth row shows 'NN a.u.' for all columns. The hundred and seventy-seventh row shows 'NN a.u.' for all columns. The hundred and seventy-eighth row shows 'NN a.u.' for all columns. The hundred and seventy-ninth row shows 'NN a.u.' for all columns. The hundred and eightieth row shows 'NN a.u.' for all columns. The hundred and eighty-first row shows 'NN a.u.' for all columns. The hundred and eighty-second row shows 'NN a.u.' for all columns. The hundred and eighty-third row shows 'NN a.u.' for all columns. The hundred and eighty-fourth row shows 'NN a.u.' for all columns. The hundred and eighty-fifth row shows 'NN a.u.' for all columns. The hundred and eighty-sixth row shows 'NN a.u.' for all columns. The hundred and eighty-seventh row shows 'NN a.u.' for all columns. The hundred and eighty-eighth row shows 'NN a.u.' for all columns. The hundred and eighty-ninth row shows 'NN a.u.' for all columns. The hundred and ninetieth row shows 'NN a.u.' for all columns. The hundred and ninety-first row shows 'NN a.u.' for all columns. The hundred and ninety-second row shows 'NN a.u.' for all columns. The hundred and ninety-third row shows 'NN a.u.' for all columns. The hundred and ninety-fourth row shows 'NN a.u.' for all columns. The hundred and ninety-fifth row shows 'NN a.u.' for all columns. The hundred and ninety-sixth row shows 'NN a.u.' for all columns. The hundred and ninety-seventh row shows 'NN a.u.' for all columns. The hundred and ninety-eighth row shows 'NN a.u.' for all columns. The hundred and ninety-ninth row shows 'NN a.u.' for all columns. The hundredth row shows 'NN a.u.' for all columns.

Status fields presence and logic depend on the SCU parameter settings (→ “SCU Technical Information”) or Analyzer manual.

Actions that can be taken when a status field is yellow or red:

- ▶ Touch the colored measured value box: The associated analyzer is displayed in the second status line.
If no analyzer shows an error: The cause is in the SCU.
- ▶ Touch several times until the menu selection (→ p. 35, § 5.5) appears and then select the menu of the analyzer or SCU involved.
- ▶ Select the menu *Diagnosis* (depends on the analyzer).

The SCU status line parameter setting is normally “Group alarm”. This means that the error message of an analyzer *not* displayed is also shown as a status message in the SCU status line.

5.5 Menu trees - what is where

Touch  (several times) to reach the top menu level.

5.5.1 Top menu level

Independent menu trees are available when operating the MCS100FT:

 Description of the respective function → p. 13, §2.2.2

- System Control Unit SCU (higher level control unit)
- MCS100FT (analyzer part of the MCS100FT system cabinet)
- FID-100FT (analyzer) (option)

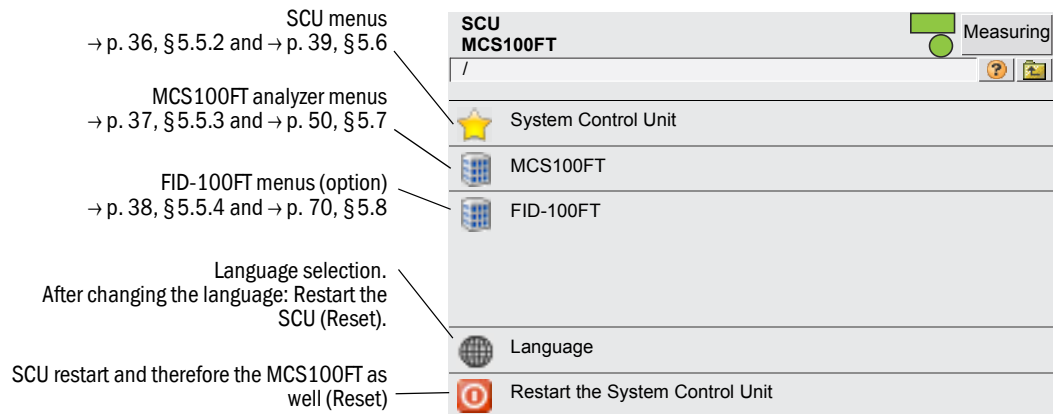

The screenshot shows a menu titled "SCU MCS100FT" with a "Measuring" indicator in the top right. The menu items are:

- System Control Unit (with a star icon)
- MCS100FT (with a grid icon)
- FID-100FT (with a grid icon)
- Language (with a globe icon)
- Restart the System Control Unit (with a red circular arrow icon)

Annotations with arrows pointing to the menu items:

- SCU menus → p. 36, §5.5.2 and → p. 39, §5.6 (points to "System Control Unit")
- MCS100FT analyzer menus → p. 37, §5.5.3 and → p. 50, §5.7 (points to "MCS100FT")
- FID-100FT menus (option) → p. 38, §5.5.4 and → p. 70, §5.8 (points to "FID-100FT")
- Language selection. After changing the language: Restart the SCU (Reset). (points to "Language")
- SCU restart and therefore the MCS100FT as well (Reset) (points to "Restart the System Control Unit")

 Some menus depend on the user level selected (password protected → p. 51, §5.7.3).
The menus for *all user levels* are shown completely in the following, however, to some extent, only those involved in operating the unprotected level are described.

5.5.2 SCU menu tree

Menu tree	Explanation
SCU	
Login	→ p. 51, §5.7.3
Upload all Parameters from Device	→ p. 51, §5.7.4
Start Screen	→ p. 40, §5.6.6
Measuring Screen	→ p. 40, §5.6.6
Measuring Screen 1 .. 8	→ p. 40, §5.6.6 ← Measuring Screen
Diagnosis (of SCU)	→ p. 43, §5.6.7
Logbook	→ p. 43, §5.6.7.1
Device	→ p. 44, §5.6.7.2
Cyclic Trigger	→ p. 44, §5.6.7.3
Parameter	→ “SCU” Technical Information manual
Measuring Screen	
I/O	
Formulas	
Status	
Variables and Functions	
Sequence Controls	
Test Gas Table	[1]
Logbook	
Logbook Texts (TXTi)	
Modbus	
Device	
Operating States Change	[1]
Maintenance	→ p. 45, §5.6.9
Tests	→ p. 45, §5.6.9.1
...	
Manual Adjust	[1]
Hardware Reset	→ p. 49, §5.6.9.3

1 This menu is not used in the SCU. Please use the appropriate MCS100FT or FID-100FT menu.

5.5.3 MCS100FT menu tree

Menu tree	Explanation
MCS100FT	
Login	→ p. 51, §5.7.3
Upload all Parameters from Device	→ p. 51, §5.7.4
Measured Values	→ p. 52, §5.7.5 ← Raw value display
Parameters	→ p. 52, §5.7.6
Device Parameters	→ p. 53, §5.7.6.1
Temperature Control	→ p. 54, §5.7.6.2
Pressure Control	→ p. 54, §5.7.6.3
Logbook	→ p. 54, §5.7.6.4
Adjustment	→ p. 55, §5.7.7
Automatically	→ p. 55, §5.7.7.1
Adjustment manual IR Components	→ p. 57, §5.7.7.2
Parameters	→ p. 58, §5.7.7.3
Diagnosis	→ p. 61, §5.7.8
Device Information	→ p. 61, §5.7.8.1
Logbook	→ p. 62, §5.7.8.2
Driftcheck (QAL3) with span gas	→ p. 66, §5.7.8.3
Driftcheck (QAL3) without span gas	→ p. 66, §5.7.8.4
Energy values	→ p. 66, §5.7.8.5
Sensor Values	→ p. 67, §5.7.8.6
Maintenance	→ p. 69, §5.7.9
Operation Mode Switch	→ p. 69, §5.7.9.1
Status Reset	→ p. 69, §5.7.9.2

5.5.4 FID-100FT menu tree







Menu tree	Explanation
FID-100FT	
Login	→ p. 51, §5.7.3
Upload all Parameters from Device	→ p. 51, §5.7.4
Measured value	→ p. 70, §5.8.3 ← Raw value display
Language	→ p. 71, §5.8.4
Parameter	→ p. 71, §5.8.5
Measured value display	→ p. 71, §5.8.5.1
Measuring range	→ p. 72, §5.8.5.2
Span gas setting	→ p. 72, §5.8.5.3
Sample gas name	→ p. 72, §5.8.5.4
Device parameters	→ p. 73, §5.8.5.5
Gas timing	→ p. 73, §5.8.5.6
Adjustment	→ p. 74, §5.8.6
Zero and responsivity	→ p. 74, §5.8.6
Zero	→ p. 74, §5.8.6
Responsivity	→ p. 74, §5.8.6
Diagnosis	→ p. 75, §5.8.7
Operating mode	→ p. 75, §5.8.7.1
Adjustment results	→ p. 76, §5.8.7.2
Logbook	→ p. 77, §5.8.7.3
Maintenance	→ p. 79, §5.8.8
Ignition	→ p. 79, §5.8.8.1
Operating mode	→ p. 79, §5.8.8.2
Test gas switch	→ p. 80, §5.8.8.3

5.6 “System Control Unit” (SCU) menus

5.6.1 Menu tree

 Complete menu tree → p. 36, §5.5.2

5.6.2 Menu selection

SCU MCS100FT	Measure
/System Control Unit/	
 Login	→ p. 39, §5.6.3
 Upload all Parameters from Device	→ p. 39, §5.6.4
 Start Screen	→ p. 40, §5.6.6
 Measuring	→ p. 40, §5.6.6
 Diagnosis	→ p. 43, §5.6.7
 Parameter	→ “SCU” Technical Information manual
 Maintenance	→ p. 45, §5.6.9

5.6.3 Login (user levels)

Menu: System Control Unit/Login

 Equivalent to the menu for the MCS100FT: MCS100FT/Login → p. 51, §5.7.3

Password

Userlevel	Designation	Allowed actions	Password ¹²
1	None	View measured values and parameters	No password
3	Authorized user	Start actions and change parameters	HIDE

¹ The password cannot be changed.

² Capital letters

 The menus of *both user levels* are described in this Manual. Menus not allowed for a user level are not displayed.

5.6.4 Upload all Parameters from Device

Menu: System Control Unit/Upload all Parameters from Device

The current parameters from the SCU memory are loaded to the SCU operating unit.

No further prompts are displayed, the parameters are loaded when the menu item is touched.

 If it is possible that parameters have been changed in the SCU via the Ethernet (e.g. via SOPAS ET):
 ► Perform “Upload all Parameters from Device” before changing parameters.

5.6.5 Start screen

Menu: System Control Unit/Start screen

The Start screen is automatically displayed after the start of the SCU or after touching the “Measure” field.

You can select the desired Start screen from the displayed list of Measuring screens (→ §5.6.6).

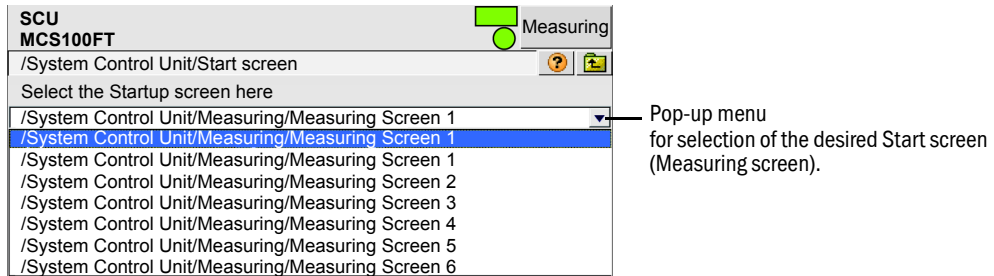

5.6.6 Measuring screen

Menu: System Control Unit/Measuring

Select the desired parametrized Measuring screen from the list shown.

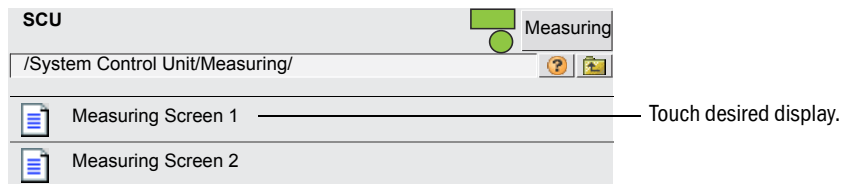

- Measuring screens comprise:
 - Measured value box (→ p. 41, §5.6.6.1)
 - Bargraph (→ p. 42, §5.6.6.2)
 - LineWriter (→ p. 42, §5.6.6.3)
- Setting Measuring Screen parameters (→ “SCU Technical Information“ manual)

 Refresh interval for display: Approx. 1 second

5.6.6.1 Measured value box (description)

A measured value box shows the measured value as *numeric* value.

(Measured box default: → “SCU Technical Information“ manual)

Typical Measuring screen:

Status line of the analyzer for which the measured value box is activated (*light brown*) is shown.

Name (e.g.: Component) - Unit

Measured value

Measured value box color:
 - *Light brown*: Activated
 - *Light blue*: Valid
 - *Gray*: Not used

Measured value field color:
 - *White*: Measured value OK
 - *Yellow*: Maintenance request/uncertain
 - *Red*: Failure

SCU MCS100FT		25.05.10 14:01	
/System Control Unit/Measuring/Measuring Screen 1			
Name	Name	NN	NN
Unit	Unit	a.u.	a.u.
701	17.3	126	
NN	NN	NN	NN
a.u.	a.u.	a.u.	a.u.
			Name
NN	NN	NN	Unit
a.u.	a.u.	a.u.	
			Name
NN	NN	NN	Unit
a.u.	a.u.	a.u.	

Touching a measured value box activates this box.

- The activated box is highlighted *light brown*.
 - If *NN* (instead of component) or *a.u.* (instead of unit) is displayed:
 - No measured value has been assigned.
 - If a measured value box is shown *gray*:
 - Measured value box not used (→ “SCU Technical Information“ manual).
- The status of the analyzer to which the activated (*light brown*) box is assigned is shown in the status line.

Scaling (measured value box, bar graph, line writer)

Touching an *activated* measured value box calls up a screen to scale the measured value box:

Character color of component or unit.

Significant positions (-99 .. +99)
 Minus sign = decimal places
 Example:
 -2: 123.45
 -1: 1234.5
 0 : 12345
 1 : 12340 (trailing zeros)
 2 : 12300

For bar graphs:
 Scale start and end.

Checkmark: Display line (Only effective for “LineWriter”)

SCU MCS100FT		Measure
/System Control Unit/Measuring/Measuring Screen 1		
Color Choice	black	
Data Dimension	-2	
Scale Start	0	
Scale End	100	
Activate	<input checked="" type="checkbox"/>	
Save		
Cancel		

5.6.6.2 **Bargraph representation (description)**

The bargraph representation shows the measured value as a graphic bar.
 (Bargraph representation default values: → “SCU Technical Information“ manual)
 Typical bargraph representation:

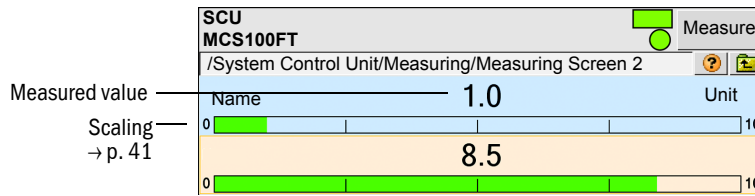

Significance and settings: → Measured value box (→ p. 41, §5.6.6.1)

5.6.6.3 **Line Writer (description)**

The LineWriter shows a maximum of 8 measured values in an y-t diagram.
 (Line writer default values: → “SCU Technical Information“ manual)
 LineWriter example:

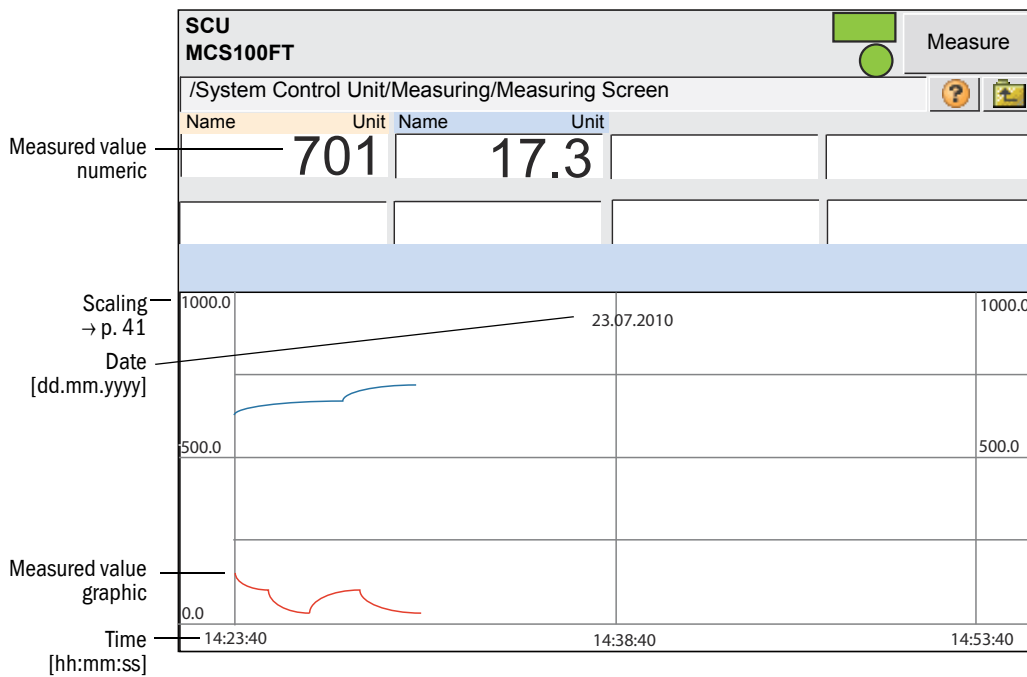

Significance and settings: → Measured value box (→ p. 41, §5.6.6.1)

5.6.7

Diagnosis

Menu: System Control Unit/Diagnosis

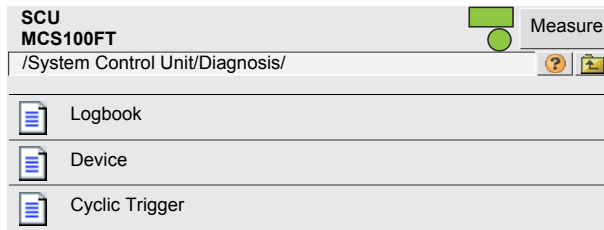

→ § 5.6.7.1

→ p. 44, § 5.6.7.2

→ p. 44, § 5.6.7.3

5.6.7.1

Logbook

Menu: System Control Unit/Diagnosis/Logbook

This menu serves to make settings for the SCU logbook.

The operation of the SCU logbook is equivalent to the operation of the MCS100FT logbook (→ p. 62, § 5.7.8.2).

Logbook entries

Logbook entry	Description	Possible cause/ clearance ¹
Failure "F" classification in logbook, status field on operator panel (→ p. 33, § 5.4) lights <i>red</i>		
Global Failure	Status of an analyzer	Error in analyzer.
DeviceOff	Connection failure	---
NotPresent		---
Mismatched	Analyzer software does not match the data record stored in the SCU.	Switch the SCU off and on again.
CouldntGetChecksum	Internal error	Please contact SICK Customer Service.
CouldntRegisterDevicIdent		
CouldntReadProclIndex		
CouldntReadDevicIdent		
CouldntReadOpState		
NoOpStateDescriptor		
CouldntReadOpStateDe- scriptor		
CouldntAddDiag		
CouldntReadProcDescr		
CouldntAddProcVal		
CouldntAddInpVal		
CouldntAddCtlVal		
UnknownValType		
CouldntGetNextCMV		
Maintenance "M" classification in logbook, status field on operator panel (→ p. 33, § 5.4) lights <i>yellow</i>		
Global Failure	Status of an analyzer	Error in analyzer.
Extended "X/E" classification in logbook, no display of further information		
OVO (Overload0nx)	Input range of nth analog input exceeded.	Check external power source.
	Desired current on nth analog output not reached.	Check external load.

Subject to change without notice

Logbook entry	Description	Possible cause/ clearance ¹
PFO (PowerFault)	Fault in internal voltages	Check voltages on the CAN nodes.
CONF (Config.Err)	Found modules do not comply with presetting	Adjust modules with default.
COM (I2C-Communication)	Communication fault on node NO	Check firm seating of I/O modules.
Global Failure	Status of an analyzer	Error in analyzer.
Uncertain "U" classification in logbook, status field on operator panel (→ p. 33, § 5.4) lights yellow		
Global Failure	Status of an analyzer	Error in analyzer.
Initializing	Connection is being established	----
Check "C" classification in logbook, status field on operator panel (→ p. 33, § 5.4) lights yellow		
Global Failure	Status of an analyzer	Error in analyzer.

¹ If fault persists: Contact SICK Customer Service.

5.6.7.2

Device information

Menu: *System Control Unit/Diagnosis/Device*

This menu shows the version numbers of the SCU.

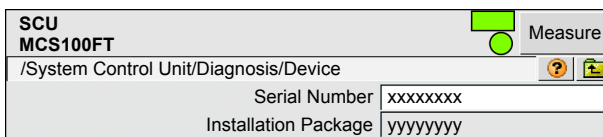

+i Have these numbers available when you have a service request concerning the SCU.

5.6.7.3

Cyclic trigger (CTi)

Menu: *System Control Unit/Diagnosis/Cyclic Trigger*

List of the next start timepoints.

Setting cyclic trigger parameters: → "SCU Technical Information" manual.

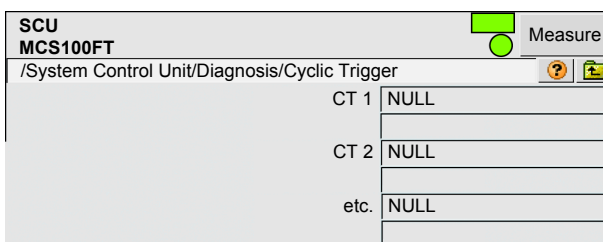

Designation	Remark
CTi	Cyclic trigger name

5.6.8 **Parameter setting**

Menu: *System Control Unit/Parameter*







This menu serves to set the SCU parameters:

- Measuring screen
- Sequence control of MCS100FT
- Logbook
- Interfaces
- etc.

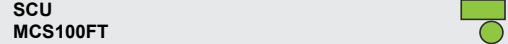
 Setting SCU parameters → “SCU Technical Information“.

5.6.9 **Maintenance**







Menu: *System Control Unit/Maintenance*

 	
/System Control Unit/Maintenance/	
 Tests	→ p. 45, § 5.6.9.1
 Manual Adjust	→ p. 49, § 5.6.9.2
 Hardware Reset	→ p. 49, § 5.6.9.3
 Maintenance Mode	→ p. 49, §

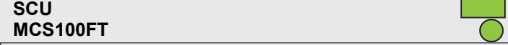
5.6.9.1 **Tests**

Menu: *System Control Unit/Maintenance/Tests*

This menu serves to test the analog and digital interfaces.

 	
/System Control Unit/Maintenance/Tests/	
 Digital Input	→ p. 46
 Digital Output	→ p. 47
 Analog Input	→ p. 48
 Analog Output	→ p. 49

 Interface menu explanation: → “SCU Technical Information“ manual
The “Save” button has no significance.

● Digital inputs

Menu: System Control Unit/Maintenance/Tests/Digital Input

SCU MCS100FT			
/System Control Unit/Maintenance/Tests/Digital Input			Measure
Save	Mark	Test	
Index	Module	Name	Inverted
1	N1M01DI01(DI04)	di1:Switch Main/Meas	<input checked="" type="checkbox"/>
2	N1M01DI02(DI04)	di2	<input type="checkbox"/>
3	N1M01DI03(DI04)	di3	<input type="checkbox"/>
etc.			

- ▶ “Mark” desired tests and then perform these tests with “Test”.
The following Test menu appears:

SCU MCS100FT	
/System Control Unit/Maintenance/Tests/Digital Input	
Index	1
Module	N1M01DI01(DI04)
DI(n) [State]	<input type="radio"/>
DI(n) [Source]	<input type="radio"/>
Cancel	

Designation	Remark
Index	Number of the selected input. Shown automatically.
Module	Topographic addressing (→ “SCU Technical Information“ manual). Shown automatically.
DI(n) [State]	Computed value of [Source] (“Inverted” is taken into consideration) .
DI(n) [Source]	LED off: Physical contact open. LED on: Physical contact closed.

● Digital outputs

Menu: System Control Unit/Maintenance/Tests/Digital Output.

SCU MCS100FT			
/System Control Unit/Maintenance/Tests/Digital Output			
Save	Mark	Test	
Index	Module	Source	Inverted
1	N1M02DO01(DO04)	bv11	<input checked="" type="checkbox"/>
2	N1M02DO02(DO04)	bv12	<input type="checkbox"/>
3	N1M02DO03(DO04)	s2e9	<input type="checkbox"/>
etc.			

► “Mark” desired tests and then perform these tests with “Test”.

The following Test menu appears:

SCU MCS100FT	
/System Control Unit/Maintenance/Tests/Digital Output	
Index	1
Module	N1M02DO01(DO04)
Test Parameter	<input checked="" type="checkbox"/>
DO(n)O [State]	<input type="radio"/>
DO(n) [Source]	<input type="radio"/>
Cancel	

Designation	Remark
Index	Number of the selected output. Shown automatically.
Module	Topographic addressing (→ “SCU Technical Information“ manual). Shown automatically.
Test Parameter	No checkmark: Physical contact should be open. Checkmark: Physical contact should be closed.
DO(n)O [State]	LED off: Relay open. LED on: Relay closed.
DO(n) [Source]	LED off: Program specification: Physical contact should be open. LED on: Program specification: Physical contact should be closed.

● Analog inputs

Menu: System Control Unit/Maintenance/Tests/Analog Input

SCU MCS100FT							
/System Control Unit/Maintenance/Tests/Analog Input							Measure
Save Mark Test							
Index	Module	Name	Unit	Gas Condition	Zero	Range Start	Range End
1	N1M14AI01(AI02)	AI1	4mA	----	4mA	0.0E00	1.0E02
2	N1M14AI02(AI02)	AI2	4mA	----	4mA	0.0E00	1.0E02
3	N1M14AI03(AI02)	ai3	4mA	----	4mA	0.0E00	1.0E02
etc.							

- ▶ “Mark” desired tests and then perform these tests with “Test”.
The following Test menu appears:

SCU MCS100FT	
/System Control Unit/Maintenance/Tests/Analog Input	
Index	1
Module	N1M14AI01(AI02)
AI(n) [mA]	12
AI(n) [phys. Unit]	701
Cancel	

Designation	Remark
Index	Number of the selected input. Shown automatically.
Module	Topographic addressing (→ “SCU Technical Information“ manual). Shown automatically.
AI(n) [mA]	Current measured on the analog input.
AI(n) [phys. Unit]	Converted physical measured value.

● Analog outputs

Menu: System Control Unit/Maintenance/Tests/Analog Output

SCU MCS100FT Measure									
/System Control Unit/Maintenance/Tests/Analog Output ? ↗									
Save			Mark			Test			
Index	Module	Source	Zero	Range1 Start	Range1 End	Range1 active	Range2 Start	Range2 End	Range2 active
1	N1M10AO01(AO02)	rv1	4mA	0.0E00	1.0E02	<input checked="" type="checkbox"/>	0.0E00	1.0E02	<input type="checkbox"/>
2	N1M10AO02(AO02)	rv2	4mA	0.0E00	1.0E02	<input checked="" type="checkbox"/>	0.0E00	1.0E02	<input type="checkbox"/>
3	N1M11AO02(AO02)	rv3	4mA	0.0E00	1.0E02	<input checked="" type="checkbox"/>	0.0E00	1.0E02	<input type="checkbox"/>
etc.									

- ▶ “Mark” desired tests and then perform these tests with “Test”.
The following Test menu appears:

SCU MCS100FT Measure	
/System Control Unit/Maintenance/Tests/Analog Output ? ↗	
Index	1
Module	N1M10AO01(AO02)
Test Parameter [mA]	12
AO(n)O [mA]	12
AO(n) [phys. Unit]	701
Cancel	

Designation	Remark
Index	Number of the selected output. Shown automatically.
Module	Topographic addressing (→ “SCU Technical Information“ manual). Shown automatically.
Test Parameter [mA]	Input: Setpoint value of the current to be output.
AO(n)O [mA]	Actual value of the current output.
AO(n) [phys. Unit]	Output value converted to the physical unit.

5.6.9.2 Manual adjust



This menu is not used in the SCU.
Please use the appropriate MCS100FT or FID-100FT menu.

5.6.9.3 Hardware reset

Menu: System Control Unit/Maintenance/Hardware Reset
Triggers an SCU restart and therefore the MCS100FT as well.

SCU MCS100FT Measure	
/System Control Unit/Maintenance/Hardware Reset ? ↗	
Hardware Reset	

5.7 **MCS100FT menus**









5.7.1 **Menu tree**

 Complete menu tree → p. 37, §5.5.3

5.7.2 **Menu selection**

Menu: *MCS100FT*

The “*MCS100FT*” menu serves to access the *MCS100FT Analyzer*.

SCU MCS100FT		 Measure
/MCS100FT/		
 Login		→ p. 51, §5.7.3
 Upload all Parameters from Device		→ p. 51, §5.7.4
 Measured Values		→ p. 52, §5.7.5
 Parameters		→ p. 52, §5.7.6
 Adjustment		→ p. 55, §5.7.7
 Diagnosis		→ p. 61, §5.7.8
 Maintenance		→ p. 69, §5.7.9

5.7.3 Login (user levels)

Menus: MCS100FT/Login and FID-100FT/Login

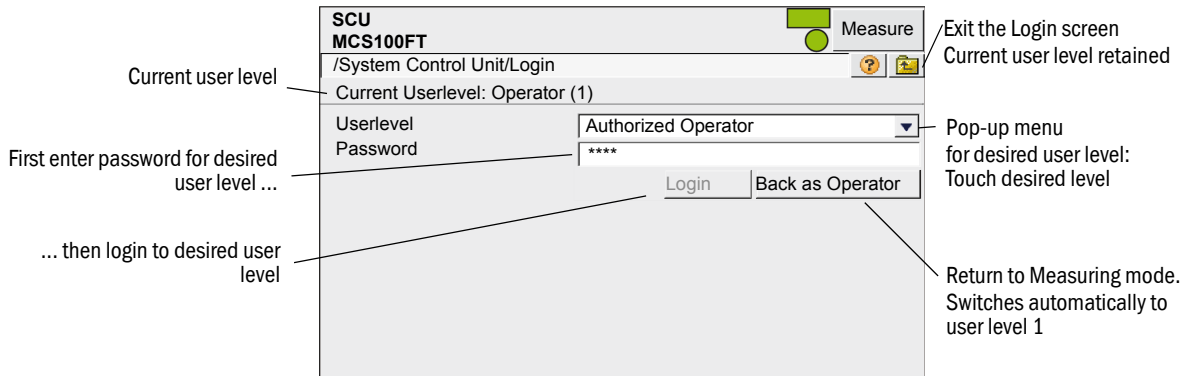

Userlevel	Designation	Allowed actions	Password ¹²
1	None	View measured values and parameters	No password
3	Authorized Operator	Start actions and change parameters	HIDE

- 1 The password cannot be changed.
- 2 Capital letters

- If there is not input in user level 3 for a period of 30 minutes, a dialog window is shown prompting for confirmation to remain at this user level.
- At user level 1, the menus of user level 3 are not shown or are blocked for inputs. The blocked fields are then *grayed out*.

 The menus of *both user levels* are described in this Manual. Menus not allowed for a user level are not displayed.

5.7.4 Upload all parameters from device

Menu: MCS100FT

The current parameters are loaded to the operator panel from the analyzer of the MCS100FT resp. FID-100FT

No further prompts are displayed, the parameters are loaded when the menu item is touched.

 If it is possible that parameters were changed on the MCS100FT resp. FID-100FT via the Ethernet (e.g. via SOPAS ET):
 ► Perform "Upload all Parameters from Device" before changing parameters.

5.7.5 Measured values

Menu: MCS100FT/Measured Values

SCU		Measure
MCS100FT		
/MCS100FT/Measured Values		
HCl mg/m3	0,366	
HF mg/m3	19,565	
NH3 mg/m3	2,736	
CO mg/m3	9,976	



This menu shows the *uncorrected* MCS100FT analyzer measured values (no moisture correction, no averaging, cross-sensitivities are corrected).

The uncorrected measured values are transferred to the SCU and computed further there (averaging and conversion to “dry flue gas”).

The *calculated* values are shown in the *System Control Unit/Measuring* menu (→ p. 40, §5.6.6).

- Update interval: Approx. 20 seconds.

5.7.6 Parameters

Menu: MCS100FT/Parameters

SCU		Measure
MCS100FT		
/MCS100FT/Parameters		
Device Parameters		→ p. 53, §5.7.6.1
Temperature Control		→ p. 54, §5.7.6.2
Pressure Control		→ p. 54, §5.7.6.3
Logbook		→ p. 54, §5.7.6.4



If it is possible that parameters were changed on the MCS100FT via the Ethernet (e.g. via SOPAS ET):

- ▶ Perform “*Upload all Parameters from Device*” (→ p. 51, §5.7.4) before changing parameters.

5.7.6.1

Device parameters

Menu: MCS100FT/Parameters/Device Parameters

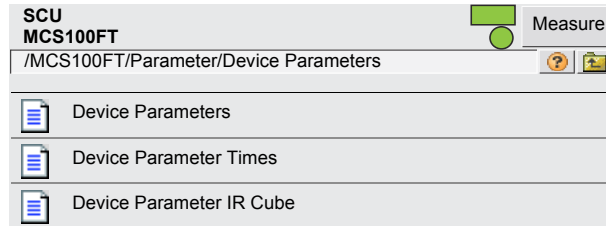

→ p. 53

→ p. 53

→ p. 53

Device parameters

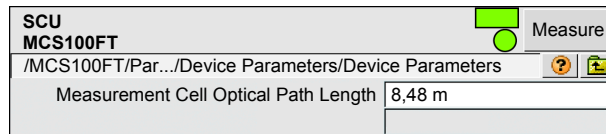

Designation	Remark
Measurement Cell Optical Path Length	Displays of optical length of sample gas cell

Device parameter times

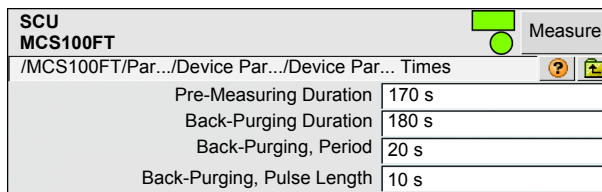

An input screen is shown after touching a field.

Designation	Remark
Pre-Measuring Duration	When Measuring mode is switched to: The specified period is defined as operating state "Pre-measuring". MCS100FT behavior (analog outputs, status signals, etc) depends on the parameter settings.
Back-Purging Duration	Back purging cycle duration
Back-Purging, Period	Interval in which the "pulse length" should occur.
Back-Purging, Pulse Length	How long back purging runs.

Device parameter IR Cube

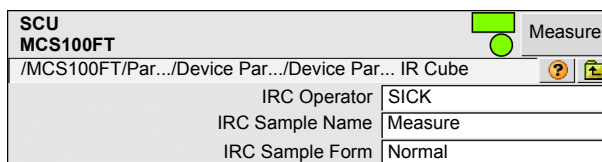

An input screen is shown after touching a field.

Designation ¹	Remark
IRC Operator	Freely selectable
IRC Sample Name	Freely selectable
IRC Sample Form	Freely selectable

¹ IRC: IR Cube

5.7.6.2 **Temperature control**

Menu: MCS100FT/Parameters/Temperature Control

This menu shows the temperature setpoints [°C].

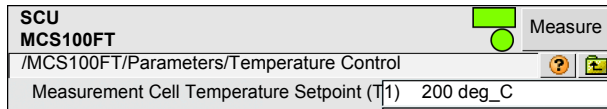

5.7.6.3 **Pressure control**

Menu: MCS100FT/Parameters/Pressure Control

This menu shows the pressure setpoint values [hPa].

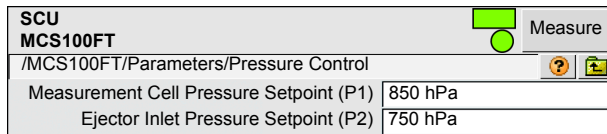

5.7.6.4 **Logbook**

Menu: MCS100FT/Parameters/Logbook

This menu serves to enter the settings for the logbook (→ p. 62, §5.7.8.2) of the MCS100FT analyzer.

(The SCU has an own setting for its own logbook → p. 43, §5.6.7.1)

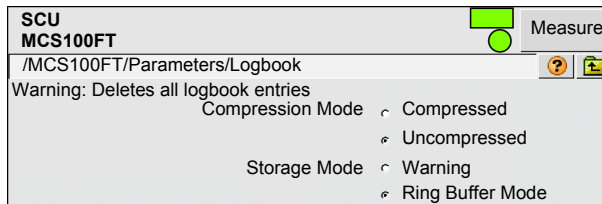

Designation	Remark
Compression Mode:	When an error occurs:
- Compressed:	- An error counter is incremented.
- Uncompressed:	- The error message is saved.
Storage Mode:	When the logbook buffer is full:
- Warning :mode	- A message is output and no further entries are stored.
- Ring Buffer Mode:	- The oldest entries are overwritten with the current entries. No relevant message is displayed.



Changing the setting deletes the logbook contents.

5.7.7

Adjustment



IMPORTANT: Incorrect adjustment when O₂ sensor is dry
 No dry gas may have been applied to the O₂ sensor for a longer period of time before it is adjusted.

- ▶ For example, perform the adjustment of the O₂ sensor *before* other components are adjusted with dry gas.

Menu: MCS100FT/Adjustment

SCU MCS100FT	Measure
/MCS100FT/Adjustment	
Automatically	→ p. 55, §5.7.7.1
Adjustment manual IR Components	→ p. 57, §5.7.7.2
Parameter	→ p. 58, §5.7.7.3

5.7.7.1

Automatically

Menu: MCS100FT/Adjustment/Automatically

This menu serves to start check and adjustment processes which then run automatically. Touching displayed components allows to select only those components that have to be checked.



Before exiting the menu, touch: “activate all used components”, otherwise it is possible that not all components used are checked in automatic checks.

To display all components again, touch: “activate all used components”.

Automatic O₂ adjustment

Menu: MCS100FT/Adjustment/Automatically/Automatic O₂ adjustment

SCU MCS100FT	Measure
/MCS100FT/Adjustment/Automatically/ Aut. O ₂ adjustment	
O ₂ Sensor Driftcheck	
O ₂ Sensor Adjustment	

Designation	Remark
O ₂ Sensor Driftcheck	Drift check of O ₂ sensor. Presetting → p. 58, §5.7.7.3.
O ₂ Sensor Adjustment	Adjustment check of O ₂ sensor. Presetting → p. 58, §5.7.7.3.

Adjustment automatically IR components

Menu: MCS100FT/Adjustment/Automatically/Adjustment automatically IR components



SCU		Measure	
MCS100FT			
/MCS100FT/.../Adjustment automatically IR components			
Zero Adjust all			
Driftcheck (QAL3) with span gas			
Adjustment with span gas			
Driftcheck (QAL3) without span gas			
Adjustment without span gas			
Cancel			
activate all used components			
1	HCl		
Active	<input checked="" type="checkbox"/>		
2	HF		
Active	<input checked="" type="checkbox"/>		
	Measure		
	32 s		
	127 s		

Designation	Remark
Zero Adjust all	Set zero point for all activated components.
Driftcheck (QAL3) with span gas	Drift check with span gas feed. The MCS100FT is then in operating state "Drift check".
Adjustment with span gas	Adjustment of selected IR component with span gas.
Driftcheck (QAL3) without span gas ¹⁾	Drift check without span gas feed. The MCS100FT is then in operating state "Drift check".
Adjustment without span gas ¹⁾	Adjustment of selected IR component without span gas.
Cancel	Cancel the current check
activate all used components	Activation of all components used.
Component	Name of component.
Active	Checkmark: Component is active.
"Operating state"	Display of current operating state of the MCS100FT.
"1234 s"	State active since [s].
"1234 s"	Remaining time [s].



¹ Optional

5.7.7.2 Adjustment manual IR Components

Menu: MCS100FT/Adjustment/Adjustment manual IR Components

SCU MCS100FT	 Measure
Menu: MCS100FT/Adjustment/Adjustment manual IR Comp.  	
Zero Adjust all	
Man. adjust activate	
Cancel	
Test Gas <input checked="" type="checkbox"/>	
	Measuring
	325 s
	23 s

Designation	Remark
Zero Adjust all	Reset all IR components to zero. The valves are switched automatically.
Man. adjust activate	A menu for adjustment start is displayed (refer to below this Table).
Cancel	Cancel the current check. The respective valve is closed.
Test Gas	For internal use only
“Operating state”	Display of current operating state of the MCS100FT.
“1234”	State active since [s].
“1234”	Remaining time [s].

SCU MCS100FT	 Measure
/MCS100FT/.../Adjustment automatically IR components  	
Zero Adjust all	
Man. adjust activate	
Cancel	
1	HCl
	9.23
Valve <input checked="" type="checkbox"/>	
Adjust. Referencepoint	
2	HF
	0.96
Valve <input checked="" type="checkbox"/>	
Adjust. Referencepoint	

Designation	Remark
Zero Adjust all	(Originates from previous menu - without significance here)
Man. adjust activate	(Originates from previous menu - without significance here)
Cancel	Cancel the current check The respective valve is closed.
Measured component	Name of measured component
“1234”	Actual measured value
Valve	Checkmark: The valve for this component is open
Adjust. Referencepoint	Set the factor of the reference point. ▶ Execute this command only when you are sure that you wish to change the factor.
	

▶ To terminate adjustment: Touch “Cancel” or go to “Measure”.

Subject to change without notice

5.7.7.3

Parameters

Menu: MCS100FT/Adjustment/Parameter

O₂ sensor

Menu: MCS100FT/Adjustment/Parameter/O₂ Sensor

This menu serves to set the adjustment parameters of the O₂ sensor.

SCU		Measure
MCS100FT		
MCS100FT/Adjustment/Parameter/O ₂ Sensor		
Span Gas 1	20.95 %	
Last Value	20.7168 %	
Valve No. 1	0	
Span Gas 2	2.1 %	
Last Value	2.1 %	
Valve No. 2	6	
Pressure on Span gas 1	959.2023 hPa	
Pressure on Span gas 2	965.4014 hPa	
Time Constant T90	20 s	
No. of Adjust. Points	2	
1 Point Adjust when Zeroadjust	<input checked="" type="checkbox"/>	

An input screen for entering the value is shown after touching a field.

Designation	Remark
Span Gas 1	Concentration of the span gas with high concentration [% by volume]. Typically instrument air.
Last Value	Last current span gas value 1.
Valve No. 1	Preset.
Span Gas 2	Concentration of the span gas with low concentration [% by volume]. Typically approx. 10% of test gas 1.
Last Value	Last current span gas value 2.
Valve No. 2	Preset.
Pressure on Span gas 1	Ambient air pressure when span gas fed
Pressure on Span gas 2	Ambient air pressure when span gas fed
Time Constant T90	Averaging (seconds).
No. of Adjust. Points:	
1	Only one span gas (Span Gas 1) is used for adjustment. Normally: 1 point adjustment with instrument air.
2	Both span gases are used for adjustment. First Span Gas 2, then Span Gas 1.
Adjust when Zeroadjust	Checkmark: Automatically adjusts during zero point adjustment also O ₂ with span gas 1.

IR components

Menu: MCS100FT/Adjustment/Parameter/IR components

This menu serves to set the parameters for the adjustment of the IR components.

The list shows the active components.

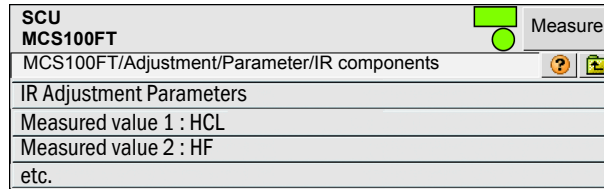

5.7.7.4

IR components/IR Adjustment Parameters

Menu: MCS100FT/Adjustment/Parameter/IR components/IR Adjustment Parameters

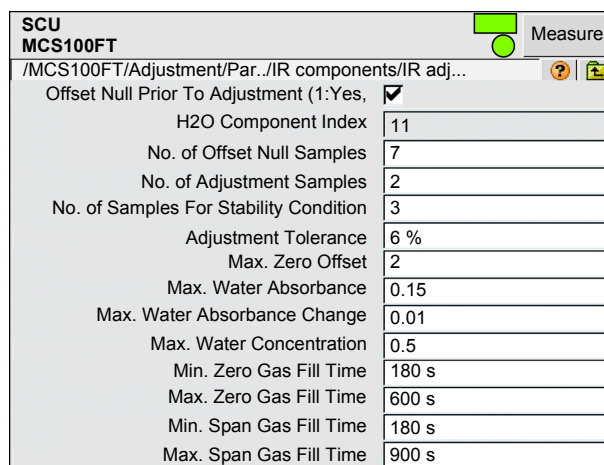

An input screen is shown after touching a field.

Designation	Remark
Offset Null Prior To Adjustment (1:Yes, 2:No)	Checkmark: Yes, duration approx. 20 minutes.
H2O Component Index	Index ("Number") of the measured value for H ₂ O. Preset.
No. Of Offset Null Samples	Number of measured values when adjusting the zero point.
No. of Adjustment Samples	Number of measured values when adjusting the reference point.
No. of Samples for Stability Condition	Number of measured values for the stability check
Adjustment Tolerance	When the difference of two successive adjustments is greater than the entered value (in %): The adjustment factor is not set and an error message output.
Max. Zero Offset	Maximum allowed offset during reset to zero. The reset to zero is not saved if the difference during reset to zero is larger than the specified offset. The unit is the unit of the respective component.
Max. Water Absorbance	When the absorbance entered is exceeded during zero adjust: Zero adjust is aborted and an error message shown.
Max. Water Absorbance Change	Criterion for stability of gas during gas feeding: Difference of H ₂ O absorbance. If, during leveling out, the value is below this "difference" between two measurements, the gas has "leveled out".

Designation	Remark
Max. Water Concentration	When the concentration entered is exceeded during zero adjust: Zero adjust is aborted and an error message shown. The unit is the one in which the water concentration is measured.
Min. Zero Gas Fill Time	Minimum level-out time for zero gas after which the stability check starts.
Max. Zero Gas Fill Time	A warning is output when leveling out has not been successful before the entered time has elapsed.
Min. Span Gas Fill Time	Minimum level-out time for span gas.
Max. Span Gas Fill Time	A warning is output when leveling out has not been successful before the entered time has elapsed.

IR components/measured value x

Menu: MCS100FT/Adjustment/Parameter/IR components/Measured value x

This menu serves to set the parameters of the span gases of the IR components.

SCU MCS100FT	
/MCS100FT/Adjustment/Parameter/Measured value x: HCl	
Unit "ppm"	<input type="checkbox"/>
	mg/m3
Mole weight	36.46 g/mol
Valve No.	4
Stability [conc.]	90
Span Gas	100
Measure gas purge	180 s
Span Factor internal	1.002
Span Factor	1.03

Designation	Remark
Dimension "ppm"	Unit of concentration. Preset: mg/m ³ Checkmark for "Unit 'ppm' active": Unit in ppm
	Unit of concentration.
Mole weight	Molecular weight of test gas. Preset.
Valve No.	Valve number of the test gas valve. Preset.
Stability [conc.]	Criterion for stability of gas during gas feeding: Difference of concentration (in unit of component) . If, during leveling out, the value between two measurements is below this "difference", the gas has "leveled out". Reference value: ±2% of full scale value.
Span Gas	Test gas concentration.
Measure gas purge	Minimum purge time for sample gas before adjustment starts [seconds].
Span Factor internal	Adjustment factor for adjustment with internal adjustment standard (filter wheel).
Span Factor	Adjustment factor for adjustment with span gas.

5.7.8

Diagnosis

Menu: MCS100FT/Diagnosis

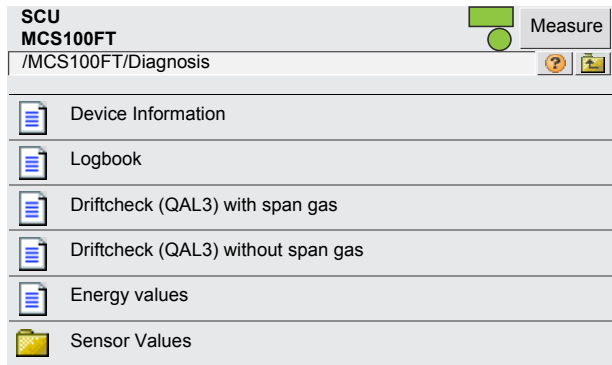

→ p. 61, §5.7.8.1

→ p. 62, §5.7.8.2

→ p. 66, §5.7.8.3

→ p. 66, §5.7.8.4

→ p. 66, §5.7.8.5

→ p. 67, §5.7.8.6

5.7.8.1

Device information

Menu: MCS100FT/Diagnosis/Device Information

Basic settings of MCS100FT.

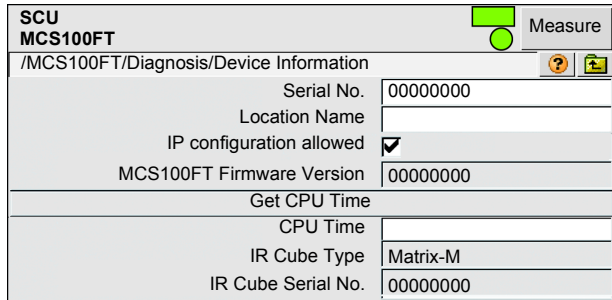





Designation	Remark
Serial No.	Serial number. Preset.
Location Name	The name entered here is shown in the menus to identify the MCS100FT (Example: "MCS100FT stack1").
IP configuration allowed	Checkmark: The IP address can be changed via SOPAS ET.
MCS100FT Firmware Version	Firmware version of the MCS100FT.
Get CPU Time	Read out internal time of the MCS100FT.
CPU Time	Display of time read.
IR Cube Type	Type of interferometer. Preset.
IR Cube Serial No.	Serial number of interferometer. Preset.







5.7.8.2

Logbook of the MCS100FT and FID-100FT

Menus: MCS100FT/Diagnosis/Logbook and FID-100FT/Diagnosis/Logbook

The *internal* status messages are recorded in the MCS100FT resp. FID-100FT logbook (separate logbooks) (format: Uncompressed data storage (SCU logbook → p. 43, § 5.6.7.1).

SCU				Measure			
MCS100FT							
/MCS100FT/Diagnosis/Logbook							
 87%		 Entries 65		Show all messages			
Reset		Update		Backward Forward			
No.	Device	Text	Class	Date Begin	Time Begin	Date End	Time End
1	System	Cell Pressure	X	yy/mm/dd	hh:mm:ss	-----	-----
2	System	Cell Flow	X	yy/mm/dd	hh:mm:ss	yy/mm/dd	hh:mm:ss
3	System	Cell Temp.	X	yy/mm/dd	hh:mm:ss	yy/mm/dd	hh:mm:ss
4	System	System start	X	yy/mm/dd	hh:mm:ss	yy/mm/dd	hh:mm:ss

Designation	Remark
	Fill level of logbook in %. When the characters are <i>red</i> : The logbook is full. Warning mode: Further entries are not accepted. Ring buffer mode: Oldest entries are overwritten.
 	Data compression: Symbol <i>not crossed out</i> : Compressed. Symbol <i>crossed out</i> : Uncompressed.
	Significance and default: → p. 54, § 5.7.6.4
 	Ring buffer mode. Warning mode. Significance and default: → p. 54, § 5.7.6.4
Entries	Current number of entries in the logbook.
Filter for messages	Only the desired messages are shown. - Show active failures - Show all failures - Show active maintenance requests - Show all maintenance requests - Show active uncertain - Show all uncertain - Show active extended messages - Show all extended messages - Show active messages - Show all messages Classification → Further on in this Table.
Reset	Clear all entries.
Export (Only in SOPAS ET)	All entries selected via the message filter (→ Further back in this Table) are saved on the PC as .log file. Format: CSV (comma-separated list). Can be read in EXCEL, for example.
Refresh	Update display of logbook entries.
Backward	Scroll back.
Forward	Scroll forward.
▲ ▼	Sort in ascending/descending order. To switch sorting on or change sequence: Click column header.
	Current number of message. <i>Red</i> LED: Message still pending. <i>Green</i> LED: Message no longer pending.

Subject to change without notice

Designation	Remark
Device name	Name of triggering unit.
Entries ¹	Number of times errors have occurred. Significance and default: → p. 54, §5.7.6.4
Text	Logbook message (see below).
Class	F = Failure M = Maintenance request C = Maintenance / Check U = Uncertain X/E = Extended
Date Begin	Format: yy-mm-dd For “Uncompressed”: Occurrence of message. For “Compressed”: Last occurrence of message.
Time Begin	Format: hh:mm:ss For “Uncompressed”: Occurrence of message. For “Compressed”: Last occurrence of message.
Date End	Format: yy-mm-dd For “Uncompressed”: Clearing of message. For “Compressed”: Last clearing of message.
Time End	Format: hh:mm:ss For “Uncompressed”: Clearing of message. For “Compressed”: Last clearing of message.

¹ Only for compressed data storage

MCS100FT logbook entries



FID-100FT logbook entries → p. 77, §5.8.7.3

Logbook entry	Description	Possible cause/ clearance ¹
Failure “F” classification in logbook, status field on operator panel (→ p. 33, §5.4) lights <i>red</i>		
Unknown command	Internal error.	Switch the MCS100FT off and on again.
OS error		
Bad Config.		
File I/O		
Numerical		
Unknown failure		
Numerical		
Spectr. resolution out of range	Spectral resolution is incorrect.	Please contact SICK Customer Service.
EEPROM	EEPROM error	Switch the MCS100FT off and on again.
IRCube comm.	Communication with interferometer interrupted	Fuse in system cabinet (→ p. 94, §8.1) switched on? Interferometer switched on? (Power plug inserted correctly? Mains switch at bottom of interferometer switched on). All 3 LEDs at the bottom of the interferometer must light. Check firm seating of the Ethernet connection between the electronics and interferometer. The Ethernet LEDs at the electronics unit must light/flash.

Logbook entry	Description	Possible cause/ clearance ¹
IOProxy comm.	Internal communication interrupted	Switch the MCS100FT off and on again.
HC3 comm.		
PC2 comm.		
Eval modul com.		
File measval	Internal file error	
File config		
File conditions		
File espec		
Absorbance calculation	Error in calculation of spectra	
Background calculation		
O2 calculation	Error in O ₂ feeding	Check O ₂ test gas supply.
O2 Span Lineconst.		
O2 Span Steepness		
O2 Span Stability		
O2 Span CANCEL	O ₂ check canceled	
Zero Waterpeakdiff.	Error during zero gas feeding	Check zero gas supply.
Zero Waterpeakvalue	Sample gas too humid determined during zero gas feeding	Check zero gas supply (specification → p. 101). This error message could also indicate that humidity has penetrated the interferometer. Check drying agent cartridge (→ p. 90, § 7.2.3).
Zero Background	Error during zero gas feeding	Check zero gas supply.
Zero CANCEL	Zero point check aborted	Check cause (additional logbook entries).
Span Zerocycle	Error during responsivity (span point) check	Check zero gas supply.
Span Tolerance		Check test gas supply.
Span Stability		
Span Watervalue		
Span CANCEL		Responsivity (span point) check aborted
IRCube Temp.	Interferometer temperature error	Check for cause within possible options (e.g. filter pad).
Fan Temp.	Temperature error of electronics unit.	
Cell Temp.	Temperature error of cell	
Cat. Temp.	Optional	----
Cell Flow	Sample gas flow erroneous	Probe/sample gas line/cell clogged? Instrument air supply present? Sample gas outlet clogged? Ejector clogged?
Cell Press	Pressure in cell incorrect	Probe/sample gas line/cell clogged? Instrument air supply present? Sample gas outlet clogged? Ejector clogged?
IR-Cube Energy	Measuring beam energy in interferometer too low	Please contact SICK Customer Service.
Maintenance request "M" classification in logbook, status field on operator panel (→ p. 33, § 5.4) lights <i>yellow</i>		
Logbook memory full	Logbook is full	Delete entries in the logbook (→ p. 62, § 5.7.8.2).

Logbook entry	Description	Possible cause/ clearance ¹
Data logging: writing data	Error when writing data	Switch the MCS100FT off and on again.
Data logging: open file		
Logbook error	Error when writing into the logbook	
Flashcard missing	No flashcard	Please contact SICK Customer Service.
Extended "X/E" classification in logbook, no display of further information		
Spectral resolution warning	Spectral resolution of interferometer is incorrect	Please contact SICK Customer Service.
Medium temperature warning	Sample gas temperature outside tolerance	Check cause as far as possible.
Medium pressure warning	Sample gas pressure erroneous	
Medium flow warning	Sample gas flow erroneous	Probe/sample gas line clogged? Instrument air supply available?
Measurement value range warning	Measurement range exceeded	- Sample gas concentration too high? - Check sample gas feed for correct state (cleanness, pressure, temperature). - Feed zero gas and check display. - Feed span gas and check display.
Measurement range x	Measurement range x	The MCS100FT has switched to measurement range x
Dig.Out x	Activation of valves	---
Uncertain "U" classification in logbook, no display of further information		
Spectral evaluation	Error in calculation of spectra	Please contact SICK Customer Service.
Numerical		
Medium temperature out of range	Sample gas temperature outside tolerance	Check cause as far as possible.
Medium pressure out of range	Sample gas pressure outside tolerance	
Medium flow out of range	Sample gas flow outside tolerance	Probe/sample gas line clogged? Instrument air supply available?
Measurement value out of range	Measurement range exceeded	- Sample gas concentration too high? - Check sample gas feed for correct state (cleanness, pressure, temperature). - Feed zero gas and check display. - Feed span gas and check display.

¹ If fault persists: Contact SICK Customer Service.

5.7.8.3 **Drift check (QAL3) with span gas**



Menu: MCS100FT/Diagnosis/Driftcheck (QAL3) with span gas

This menu serves to display the results of the drift check “with span gas”.

 To refresh the Table, perform “Upload all Parameters from Device” (→ p. 51, §5.7.4).

SCU
MCS100FT
Measure

Menu: MCS100FT/Diagnosis/Driftcheck (QAL3) with span gas

Mark	Copy				
MV	Name	Dimension	Nominal	actual	actual Zero
MV1	HCl	mg/m3	1.0E02	1.0E02	0.0E00
MV2	HF	mg/m3	1.0E02	1.0E02	0.0E00
MV3	NH3	mg/m3	1.0E02	1.0E02	0.0E00
etc.					

Designation	Remark
MV	Measured value number of component. Preset.
Name	Name of component. Preset.
Dimension	Unit of concentration. Preset.
Nominal	Nominal concentration of reference value.
actual	Actual concentration of the reference value last measured (without span gas)
actual Zero	Actual concentration of the zero value last measured (with span gas)

5.7.8.4 **Driftcheck (QAL3) without span gas**

Menu: MCS100FT/Diagnosis/Driftcheck (QAL3) without span gas

This menu serves to display the results of the drift check “without span gas”.

The menu is equivalent to menu Drift check (QAL3) with span gas (see above).

5.7.8.5 **Energy values**

Menu: MCS100FT/Diagnosis/Energy values

This menu serves to display 3 energies of the wavelength ranges.

5.7.8.6 **Sensor values**

Menu: *MCS100FT/Diagnosis/Sensor Values*

The respective sensor values are displayed in these menus.

This menu serves exclusively for service purposes.

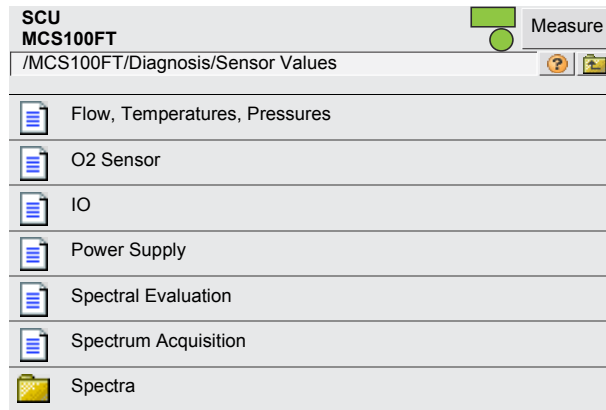

→ p. 68 (only in SOPAS ET)

Spectra (only in SOPAS ET)

Menu: MCS100FT/Diagnosis/Sensor Values/Spectra

Various spectra can be viewed in this menu.

- Reference spectrum
Single-channel performance spectrum for zero gas feeding.
This spectrum is saved after every zero adjustment
- Measurement spectrum
Single-channel performance spectrum for sample gas feeding.
This spectrum is continuously updated during measurement
- Zero gas absorbance spectrum
This spectrum is the absorbance spectrum of the zero gas.
Zero gas is fed as sample gas.
- Absorbance spectrum without baseline correction

$$\text{Absorbancespectrum} = \log \frac{\text{Referenzcspectrum}}{\text{Measurementspectrum}}$$

- Absorbance spectrum

$$\text{Absorbancespectrum} = \left(\log \frac{\text{Referencespectrum}}{\text{Measurementspectrum}} \right) \pm \text{Baseline}$$

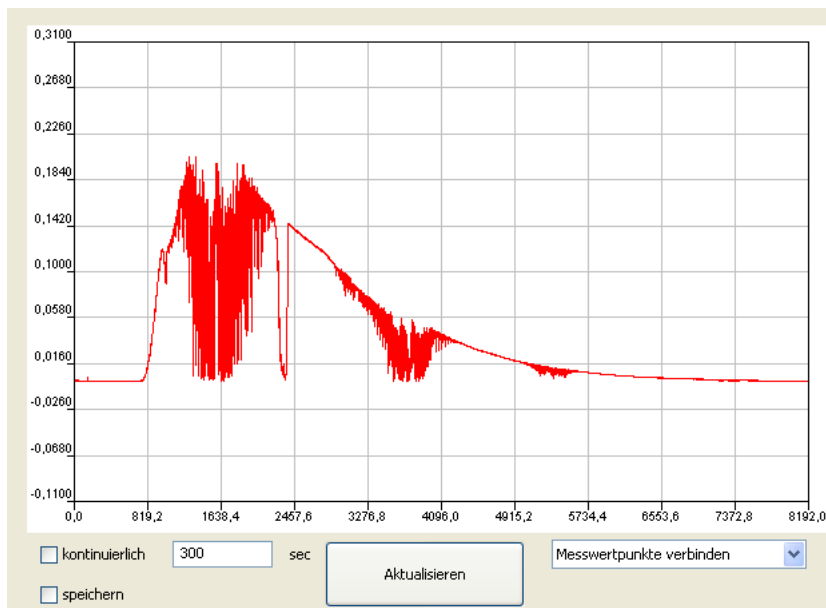

Click two points in the spectrum to zoom sections of the spectrum.

Designation	Significance
Ordinate	Performance [absorbance]
Abscissa	Wave number [cm ⁻¹]
Continuous	The displayed spectrum is continuously refreshed.
Time	Time interval of continuous display.
Save	Save spectrum.
Refresh	Refresh spectrum.
Connect measured points	Connect measured points (line display)
Show individual measured points	Show individual measured points.

Subject to change without notice

5.7.9

Maintenance

Menu: MCS100FT/Maintenance

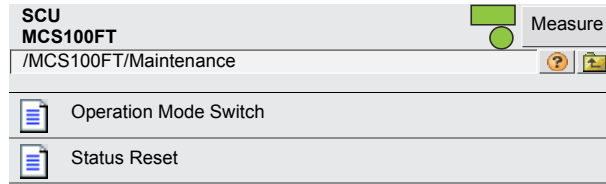

→ p. 69, § 5.7.9.1

→ p. 69, § 5.7.9.2

5.7.9.1

Operation Mode Switch

Menu: MCS100FT/Maintenance/Operation Mode Switch

This menu serves to switch the MCS100FT to the desired operating state.

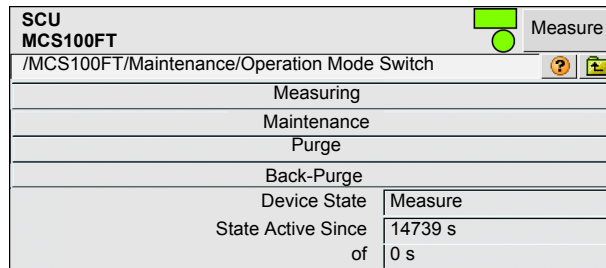

Designation	Remark
Measuring	Switch the MCS100FT to measuring operation.
Maintenance	Switch Maintenance mode on. - A status signal (→ delivered system documentation) is set. - The <i>yellow</i> status indicator on the cabinet door lights. - An entry is made in the logbook.
Back-Purge	Backflushing runs once. Duration and cycle as per parameter settings in → p. 53, § 5.7.6.1. Then automatic return to “Measuring”.
Purge	MCS100FT sampling probe, sample gas line and gas path are purged with instrument air. A status signal (→ delivered system documentation) is set.
Device State	Shows the operating state.
State Active Since	State Active Since
of	For programs running automatically: Remaining time.

5.7.9.2

Status Reset

Menu: MCS100FT/Maintenance/Status Reset

All pending messages are reset.

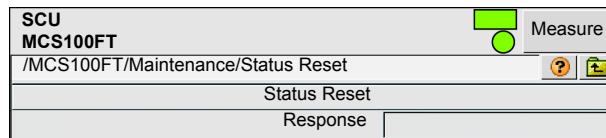











Designation	Remark
Status Reset	Reset all pending messages.
Response	Result of reset.

5.8 FID-100FT menus (option)

5.8.1 Menu tree

 Complete menu tree → p. 38, §5.5.4





5.8.2 Selection

SCU FID-100FT	Measure
/FID-100FT/	 
 Login	→ p. 51, §5.7.3
 Upload all Parameters from Device	→ p. 51, §5.7.4
 Measured value [1]	→ p. 70, §5.8.3
 Language	→ p. 71, §5.8.4
 Parameter	→ p. 71, §5.8.5
 Adjustment	→ p. 74, §5.8.6
 Diagnosis	→ p. 75, §5.8.7
 Maintenance	→ p. 79, §5.8.8

5.8.3 Measured value

Menu: FID-100FT/Measured Value

Parameter setting → p. 71, §5.8.5.1

SCU FID-100FT	Measure
/FID-100FT/Measured Value[1]	 
Measuring 	
CnHm mg org C	
1,0	
Maintenance request 	
Failure 	

LED	... when LED on:
Measuring	MCS100FT is in operating state "Measuring"
Maintenance request	MCS100FT is in operating state "Maintenance request"
Failure	MCS100FT is in operating state "Failure"

5.8.4 Language

Menu: FID-100FT/Parameter/Language

Selects the language for FID error messages and logbook entries.

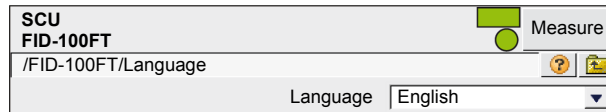

5.8.5 Parameter

Menu: FID-100FT/Parameter

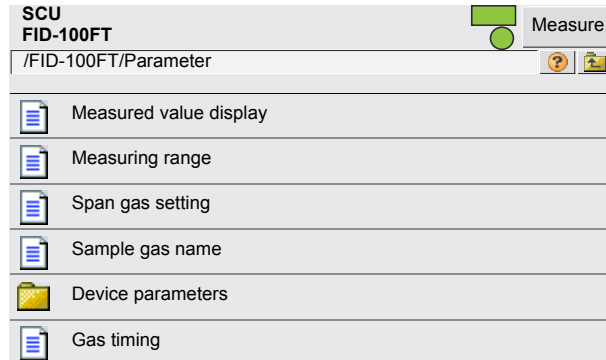

→ p. 71, §5.8.5.1

→ p. 72, §5.8.5.2

→ p. 72, §5.8.5.3

→ p. 72, §5.8.5.4

→ p. 73, §5.8.5.5

→ p. 73, §5.8.5.6

5.8.5.1 Measured value display

Menu: FID-100FT/Parameter/Measured value display

This menu serves to set parameters for the measured value display (number of decimal places).

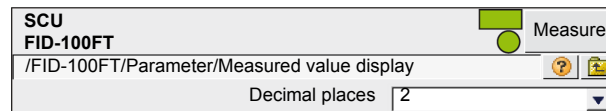

5.8.5.2 **Measurement range**

This menu serves to set the parameters for the measurement range.

SCU FID-100FT		 Measure
/FID-100FT/Parameter/Measurement range		
Measurement range	15	
Unit	mg org C	

Designation	Remark
Measurement range	Full scale value (full scale value value is always "0")
Unit	ppm or mg org. C/m ³

5.8.5.3 **Span gas setting**

Menu: FID-100FT/Parameter/Span gas setting

This menu serves to enter the span gas name and concentration. Span gas concentration: Approx. 80% of the measurement range set.

SCU FID-100FT		 Measure
/FID-100FT/Parameter/Span gas setting		
Span gas value	80ppm	
Span gas name	Propan	

5.8.5.4 **Sample gas name**

Menu: FID-100FT/Parameter/Sample gas name

This menu serves to enter the sample gas name (freely selectable).

SCU FID-100FT		 Measure
/FID-100FT/Parameter/Sample gas name		
Sample gas name	CnHm	

5.8.5.5 **Device parameters**

Menu: FID-100FT/Parameter/Device parameters

This menu serves to display and enter device parameters.

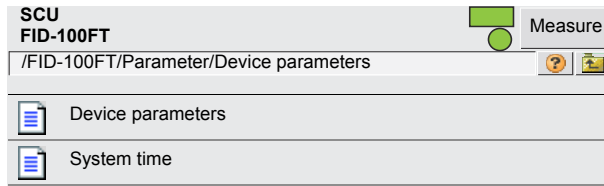

Submenu	Designation	Remark
Device parameters	Serial No.	Serial number display
	Fitting location	Entry box for sampling point (fitting location) name
System time	System time	Date and time display

5.8.5.6 **Gas timing**

Menu: FID-100FT/Parameter/Gas timing

This menu serves to set the purge times for automatic adjustment

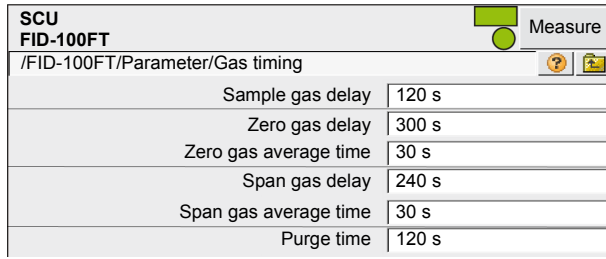

Designation	Remark
Sample gas delay	Purge time [s] with sample gas after adjustment completion until the measured value is released again.
Zero gas delay	Purge time [s] with zero gas after zero gas activated during adjustment. The averaging time then starts.
Zero gas average time	Averaging time [s] for zero gas during zero point adjustment.
Span gas delay	Purge time [s] with span gas after span gas activated during adjustment. The averaging time then starts.
Span gas average time	Averaging time [s] for span gas during span gas adjustment.
Purge time	Purge time [s] with zero gas after adjustment completion until the measured value is released again.

5.8.6

Adjustment

Menu: FID-100FT/Adjustment

Select desired adjustment:

- Zero and responsivity (span point)
- Only zero point
- Only responsivity (span point)
- ▶ Start automatic adjustment.

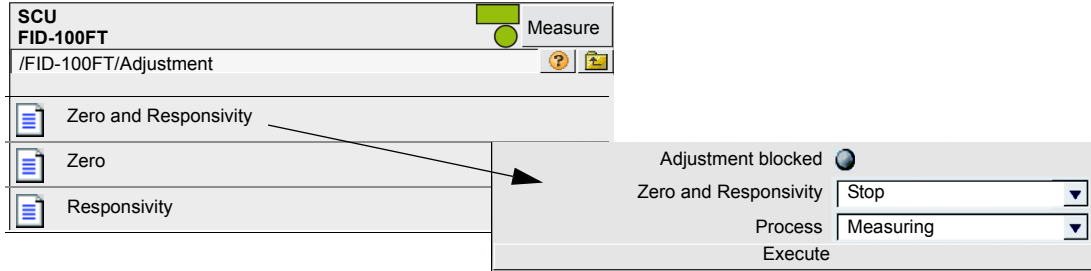

Designation	Remark
Adjustment blocked	LED on: Adjustment blocked by MCS100FT internal sequences. Wait until the LED goes off.
Zero and Responsivity	Start: Select "Start"
Zero	Terminate: Select "Stop"
Responsivity	
Process	Current device state
Execute	Execute selection

5.8.7

Diagnosis

Menu: FID-100FT/Diagnosis

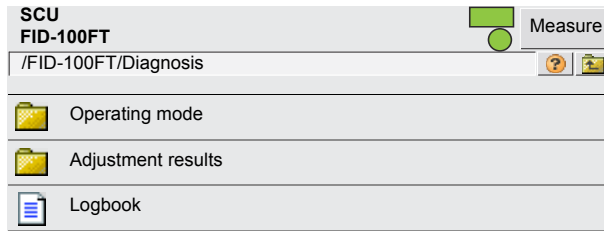

→ p. 75, §5.8.7.1

→ p. 76, §5.8.7.2

→ p. 77, §5.8.7.3

5.8.7.1

Operating mode

Menu: FID-100FT/Diagnosis/Operating mode

This menu shows the operating modes.

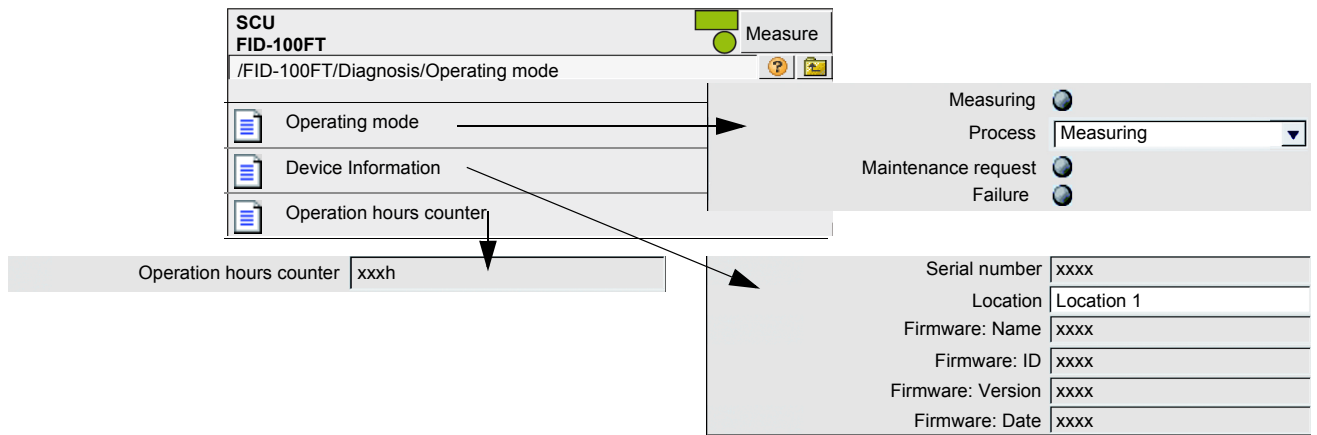

Significance of LEDs → p. 70, §5.8.3

5.8.7.2

Adjustment results

Menu: FID-100FT/Diagnosis/Adjustment results

Displays the adjustment results.

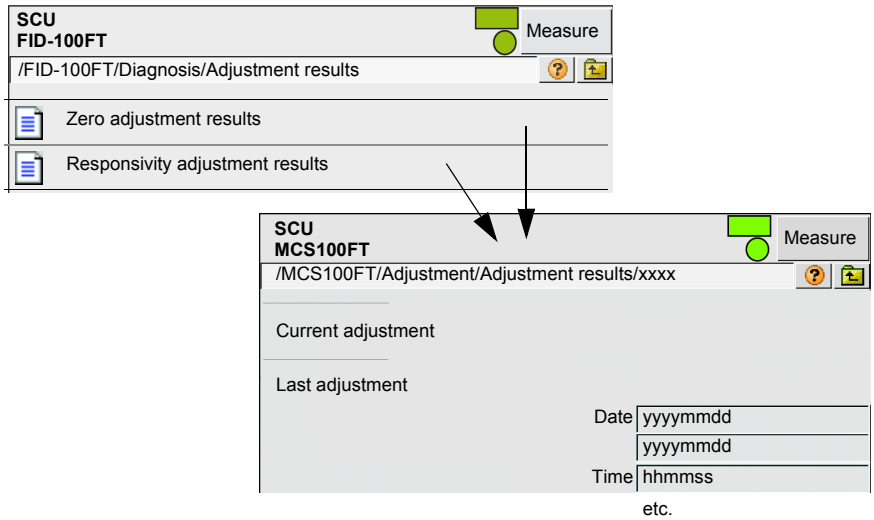

Designation	Remark
Current adjustment	Drift since "last adjustment" (top line in each case)
Last adjustment	Drift since factory calibration (bottom line in each case)
Date	Date of respective adjustment [jjjjmmtt]
Time	Time of respective adjustment [hhmmss]
Zero drift abs.	Absolute drift since last adjustment. Limit value as default. A message occurs when exceeded
Span drift abs.	Absolute drift since last adjustment. Limit value as default. A message occurs when exceeded
Zero drift rel.	Relative drift since last adjustment. Limit value as default. A message occurs when exceeded
Span gas drift rel.	Relative drift since last adjustment. Limit value as default. A message occurs when exceeded
Span gas value	Span gas concentration set. (only shown for sensitivity drift)
Span gas name	Span gas name. (only shown for sensitivity drift)
Measurement range	Full scale value
Measuring unit	Sample gas unit.

5.8.7.3

FID-100FT logbook

Menu: FID-100FT/Diagnosis/Logbook



Logbook explanation → p. 62, §5.7.8.2

Logbook entry	Description	Possible cause/ clearance ¹
Failure "F" classification in logbook, status field on operator panel (→ p. 33, § 5.4) lights <i>red</i>		
programming-error	Error in device process.	Switch the MCS100FT off and on again.
software-error	Error in internal device software.	
division by zero	Division by zero.	
calculation-overflow	Calculation error.	
EEPROM is defective.	EEPROM defective.	
Watchdog	Program monitoring time exceeded.	
I2C-interface-module-error	Internal device communication interrupted.	
PC2_FLAM-interface-module-error	Communication with Combustion Air and Fuel Gas Control module interrupted.	
FIDCB-interface-module-error	Fault in FID electronics.	
high-voltage-supply-warning	Device high voltage incorrect.	
Wrong parameter	Check parameter settings.	Changes only possible in the password protected user level.
setup-data-not-available	Setup data not available.	
EEPROM-checksum-error	EEPROM checksum for parameter settings incorrect.	Modify the MCS100FT parameter settings. This is only possible in the password protected user level.
pressure-fuel-gas	Fuel gas pressure outside tolerance.	Check fuel gas supply. Switch the MCS100FT off and on again. if this does not help → Contact SICK Customer Service.
pressure-combustion-air	Combustion air pressure outside tolerance.	Check combustion air supply. Switch the MCS100FT off and on again. if this does not help → Contact SICK Customer Service.
fuel-gas-supply	Fuel gas pressure too low.	Check fuel gas supply.
flameout	Flame no longer burning or cannot be ignited.	Check fuel gas supply. Ignite flame again → p. 79, § 5.8.8.1
flame-control-sensor-defective	Flame temperature sensor defective.	Please contact SICK Customer Service.
zero-gas-calibration-not-possible	Zero point adjustment not possible.	Check zero gas supply. Clear error through ignition and (→ p. 79, § 5.8.8.1) start adjustment again.
error-zero-calibration-drift	Zero drift outside tolerance.	
span-gas-calibration-not-possible	Responsivity (span point) adjustment not possible.	Check test gas supply. Clear error through ignition and (→ p. 79, § 5.8.8.1) start adjustment again.
error-span-calibration-drift	Responsivity (span point) drift outside tolerance.	
Maintenance "M" classification in logbook, status field on operator panel (→ p. 33, § 5.4) lights <i>yellow</i>		
service-mode-is-ON	Maintenance mode activated manually.	→ Operation Mode Switch → p. 79, § 5.8.8.2
realtime-clock-not-set	Date and time not set.	Set date and time → p. 73, § 5.8.5.5

Subject to change without notice

Logbook entry	Description	Possible cause/ clearance ¹
PC2-FLAM-module-overload	Overload on an A/D transducer in the Combustion Air and Fuel Gas Control module.	Check gas paths and gas pressures. Switch the MCS100FT off and on again.
FIDCB-module-overload	Overload on an A/D transducer in the FID electronics.	
high-voltage-supply-warning	Device high voltage incorrect.	The device can still be used but must be checked → Contact SICK Customer Service.
pressure-fuel-gas	Fuel gas pressure at tolerance threshold.	Check fuel gas supply. If this does not help: The device can still be used but must be checked → Contact SICK Customer Service
pressure-combustion-air	Combustion air pressure at tolerance threshold.	Check combustion air supply. If this does not help: The device can still be used but must be checked → Contact SICK Customer Service
Warning-zero-calibration-drift	Zero drift at tolerance threshold.	Check zero gas supply. If this does not help: The device can still be used but must be checked → Contact SICK Customer Service
Warning-span-calibration-drift	Responsivity (span point) drift at tolerance threshold.	Check test gas supply. If this does not help: The device can still be used but must be checked → Contact SICK Customer Service
Warning-No-Span-Gas/Sensitivity	Responsivity (span point) adjustment has no sensitivity. Test gas supply has no pressure or the defined test gas concentration does not match the actual test gas supply.	Check test gas supply and values. Clear error through ignition and (→ p. 79, § 5.8.8.1) start adjustment again.
Warning-open-logging-file-errorer	Error in Logbook management.	The device can still be used but must be checked → Contact SICK Customer Service.
Warning-logging-file-write-err		
Warning-logbook-error		

¹ If fault persists: Contact SICK Customer Service.

5.8.8 **Maintenance**

Menu: FID-100FT/Maintenance

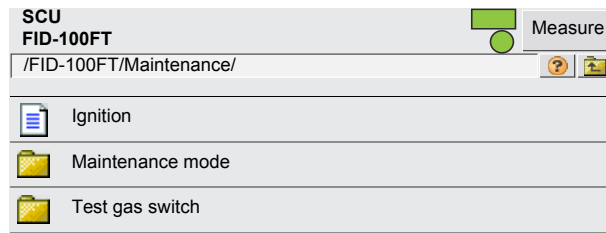

→ p. 79, §5.8.8.1

→ p. 79, §5.8.8.2

→ p. 80, §5.8.8.3

5.8.8.1 **Ignition**

Menu: FID-100FT/Maintenance/Ignition

The FID ignites automatically during start-up.
This menu serves to start ignition manually.
The LED goes on when the flame is burning.

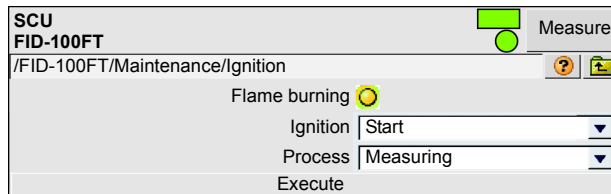

If the FID does not ignite → p. 96, §8.6

5.8.8.2 **Maintenance mode**

Menu: FID-100FT/Maintenance/Maintenance mode

This menu serves to switch the operating state from “Measuring” to “Maintenance” (and vice-versa).

In “Maintenance”, maintenance mode is just signaled and the FID-100FT continues to run.
Parameter data are blended in automatically.

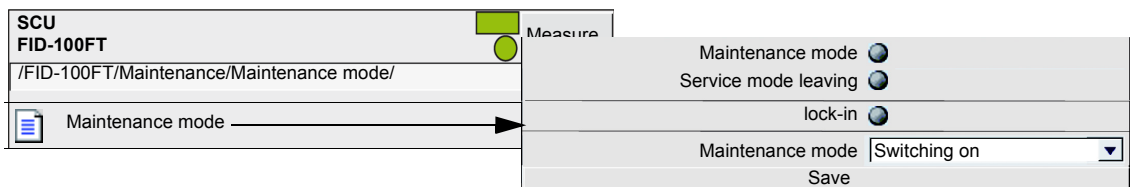

Designation	Remark
Measuring	Select operating state “Measuring”
Process	“Internal process” display (for information only)
Maintenance mode	LED on: Operation mode “Maintenance” active
Service mode leaving	Delay time until the FID-100FT switched automatically to Measuring mode.
lock-in	Maintenance mode cannot be exited. Please contact SICK Customer Service.
Maintenance mode	Select Maintenance mode

5.8.8.3 Switching test gases on/off

Menus: FID-100FT/Maintenance/Zero gas switch and FID-100FT/Maintenance/Test gas switch

This menu serves to switch zero resp. test gas on and off manually.

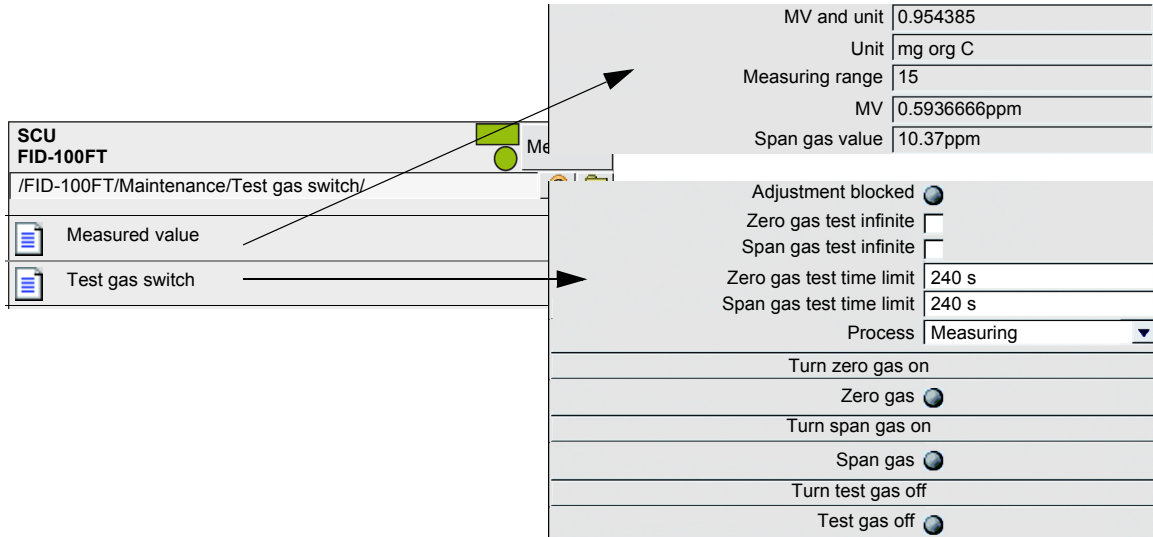

Designation	Remark
MV and unit	Measured value in the unit of the measured value (next line)
Unit	Measured value unit
Measuring range	Full scale value (FS)
MV	Measured value converted to the span gas unit (next line)
Span gas value	Span gas value with unit
Adjustment blocked	LED on: Adjustment cannot be carried out (due to, for example, internal FID-100FT sequences)
Zero gas test / Span gas test infinite	Gas remains switched on or off for an unlimited time.
Zero gas test / Span gas test time limit	Max. switch on duration
Process	"Internal process" display (for information only)
Turn zero gas on	Button serves to switch zero gas on. LED "Zero gas" then goes on.
Turn span gas on	Button serves to switch span gas on. LED "Span gas" then goes on.
Turn test gas off	Button serves to switch zero resp. span gas off again. LED "Test gas off" then goes on.

5.9 **Starting important operating sequences**

5.9.1 **Purge system with instrument air**

Menu: *MCS100FT/Maintenance/Operation Mode Switch* (→ p. 69, §5.7.9.1)

5.9.2 **Checking and adjusting with test gas**

- MCS100FT:
Menu: *MCS100FT/Adjustment* (→ p. 55, §5.7.7)
- FID-100FT
Menu: *FID-100FT/Adjustment/Zero point* (→ p. 74, §5.8.6)
Menu: *FID-100FT/Maintenance/Test gas switch* (→ p. 80, §5.8.8.3)

5.9.3 **Checking without test gas (option)**

- MCS100FT:
Menu: *MCS100FT/Adjustment* (→ p. 55, §5.7.7)

MCS100FT

6 Shutdown

Switching off the MCS100FT
Shutting down the MCS100FT
Transport
Disposal

6.1

Switching off (for a period up to approx. 2 weeks)

- 1 Set a maintenance signal (menu : *MCS100FT/Maintenance/Operation Mode Switch* → p. 69, §5.7.9.1).
- 2 For MCS100FT with FID-100FT: Switch off H₂ supply at the external stopcock.
- 3 Switch the MCS100FT to purge mode (menu: *MCS100FT/Maintenance/Operation Mode Switch* → p. 69, §5.7.9.1)
- 4 Run the measuring system in this condition for at least 15 minutes.
- 5 Set the device switch to the "OFF" position.
Caution: Do not switch off the instrument air



Moisture in the interferometer causes damage.

- With the power switched off, the sample gas path and the interferometer are automatically purged with instrument air.
- ▶ Continue to ensure the quality of the instrument air (specification → p. 101).



The thermostatic control of the sampling probe is switched off.

- ▶ Ensure the sampling probe will not become soiled.

6.2

Shutting down

- ▶ Switch the MCS100FT off (→ p. 84, §6.1).
- The shutdown of the MCS100FT may be performed by trained personnel only.



Moisture in the interferometer causes damage.

- ▶ Check the drying agent cartridge monthly even after shutting down (→ p. 90, §7.2.3).

- 1 Make sure no more flue gas can be suctioned in.
- 2 Make sure the sampling probe cannot get soiled (for example, pull the probe tube off).
- 3 Shut instrument air off.
- 4 Switch off all fuses in the MCS100FT (→ p. 89, §7.2).
- 5 Disconnect all MCS100FT poles from the mains.
- 6 Purge all lines and valves carrying sample gas with inert gas.
- 7 Close gas inlets and outlets off airtight.

6.3

Transport

The MCS100FT contains subassemblies requiring transport safety devices.

- Preparation for transport may be performed by trained personnel only.

6.4

Storage

Recommendation: Store the MCS100FT in dry conditions whenever possible.



Moisture in the interferometer causes damage.

- ▶ Check drying agent cartridge of the interferometer monthly when stored (→ p. 90, §7.2.3).

6.5

Disposal



Observe the relevant local conditions for the disposal of industrial waste.

The following subassemblies could contain substances that have to be disposed of separately:

- *Electronics*: Capacitors, rechargeable batteries, batteries.
- *Display*: Liquid of LC display.
- *Sample gas filters*: Sample gas filters could be contaminated by pollutants.

MCS100FT

7 Scheduled Maintenance

Maintenance plan

Spare parts

7.1 Maintenance intervals

Maintenance work	Reference	W ¹	Q ¹	H ¹	Y ¹
System cabinet					
Check measured values for plausibility	----	x	x	x	x
Visual check of system cabinet	→ p. 89, § 7.2.1		x	x	x
Replace filter pad for fan	→ p. 89, § 7.2.2		x	x	x
Replace filter pad for air outlet ²	→ p. 89, § 7.2.2		x	x	x
Check drying agent cartridge	→ p. 90, § 7.2.3		x	x	x
Maintenance by trained personnel	----			x	x

¹ W = weekly Q = quarterly, H = half-yearly, Y = yearly

² Only for the "IP54" version

7.1.1 Recommended spare parts for 2 years operation

Recommended spare parts	Number	Part No.
Filter pad for cabinet fan	8 ¹	5309684
Filter pad for air outlet	8 ²	On request
Drying agent cartridge, interferometer ³	1	5320799

¹ As required

² Only for the "IP54" version as required

³ *Recommendation:* In case moisture has penetrated the interferometer.

7.2 Description of maintenance work



The interferometer contains a laser.

⊗ Do not open any parts of the interferometer enclosure.

7.2.1 Visual control

MCS100FT

- *Status line on the operator panel:* Status field must light green.
If not: See logbook for cause.
- *Logbook:* Check for special entries.
- *Sample gas outlet:* Continuity, deposits.
- *System cabinet:* Visual check of the inside for
 - Dryness
 - Corrosion
 - Unusual odor
 - Unusual noises

Peripherals

- *Sample gas sampling:* Condition.
- *Test gas supply:* Condition, availability (use-by date), pressures.

7.2.2 Renewing the fan pad

Spare parts	Part No.
Filter pad for cabinet fan	5309684
Filter pad air outlet (for version "IP54")	5309684

The MCS100FT does not have to be switched off.

- 1 Remove the fan grill.
- 2 Insert a new fan pad *immediately*.
- 3 Refit the fan grill.

7.2.3 Checking/replacing the drying agent cartridge in the interferometer

Spare part ¹	Part No.
Drying agent cartridge	5320799

¹ As required

The interferometer contains a drying agent cartridge.

An indicator field shows the condition of the drying agent cartridge.

Fig. 12 Location of the drying agent cartridge in the interferometer

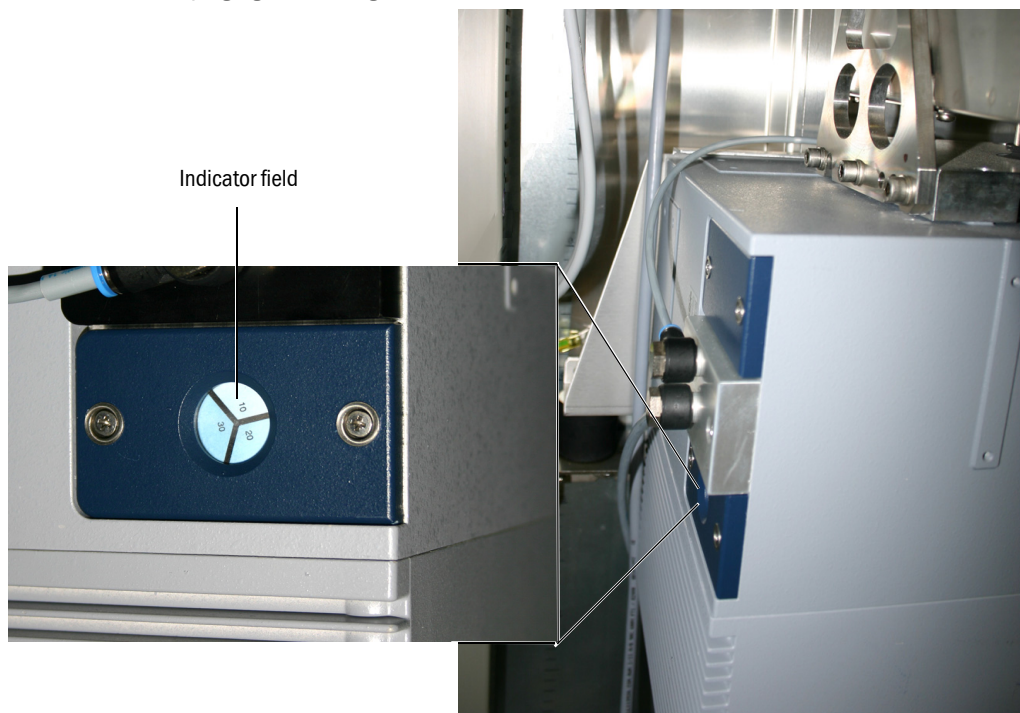

- Indicator fields are *white/light blue*: Drying agent cartridge is dry.
- One indicator field is *light red*: Drying agent cartridge is moist.



Moisture in the interferometer causes damage.

When one indicator field is *light red*:

- ▶ Check cause (e.g. condition of the instrument air supply).
- ▶ Replace drying agent cartridge (→ p. 91, § 7.2.3.1).

7.2.3.1 **Procedure to replace the drying agent cartridge**
The MCS100FT does not have to be switched off.

Fig. 13 Replace the drying agent cartridge

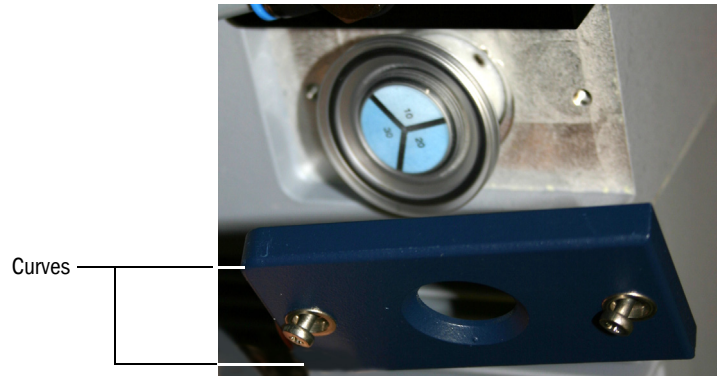

- 1 Loosen 2 screws of the cover (Phillips screwdriver) and remove cover.
 - 2 Pull out the drying agent cartridge.
 - 3 *Immediately* insert new drying agent cartridge.
 - 4 Reinstall the cover (curves “at the rear”) and screw tight.
- *Recommendation:* Keep a new drying agent cartridge in storage.

MCS100FT

8 Clearing Malfunctions

Fuses

Status messages

Implausible measured values

FID-100FT does not ignite

8.1 Fuses

Fig. 14 Fuses, system cabinet

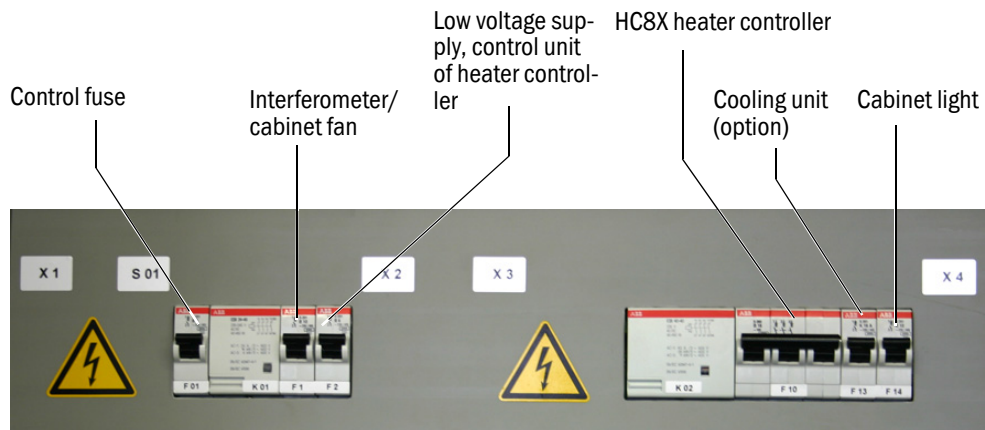

 It is possible that the fuses of your MCS100FT have a different assignment.
 ► Refer to the delivered System Documentation for fuse assignment.

8.2 Faults on the monitor

Error	Possible cause	Remarks ¹
Monitor is blank. - "POWER" LED not on.	No supply voltage.	Check voltage supply (power supply unit) and supply lines.
	Monitor is defective.	SCU itself is ready for operation.
Monitor illuminates. "POWER" LED not on.	Program not running.	Switch the voltage supply (power supply unit) off and on.
Touch operation not possible	Monitor is dirty.	Clean monitor with a damp cloth and, when necessary, with a detergent.
	Incorrect touch calibration	Reset from SOPAS ET (→ "SCU Technical Information" manual)
Monitor too bright or too dark	Monitor defective	Setting is not possible. Please contact SICK Customer Service.

¹ If fault persists: Contact SICK Customer Service.

8.3 Indicators on the operator panel

8.3.1 Status field *red* - “Stand-By“

When a malfunction occurs, MCS100FT switches automatically to “Stand-by”.

In this state:

- MCS100FT status field is *red*.
- A status signal is set.
- The sample gas path (including sampling probe) is purged with instrument air.
- For FID-100FT: The FID-100FT fuel gas supply is switched off.
- A relevant error message is displayed on the operator panel and entered in the logbook (→ p. 62, §5.7.8.2).
- ▶ Correct the malfunction or have it corrected by trained personnel.
If it was possible to correct the malfunction without switching the MCS100FT off (e.g. clearing a jam when the “sample gas flow” malfunction occurred), the MCS100FT automatically switches back to Measuring mode.

8.3.2 “Current menu level” is *red*

When the current menu level is highlighted *red*:

The connection from MCS100FT resp. FID-100FT to SCU is interrupted.

SCU Analyzer			F 25.05.10 14:01
/System Control Unit/Measuring/Measuring Screen			
Component Unit	Component Unit	Component Unit	NN a.u.
701	17.3	126	
NN a.u.	NN a.u.	NN a.u.	NN a.u.

Current menu level

- 1 Touch several times until the menu selection (→ p. 35, §5.5) appears and then select the menu of the analyzer or SCU involved.
The SCU and the MCS100FT or the FID-100FT regain contact.
If the connection is not established:
 - Check connection between MCS100FT resp. FID-100FT and SCU.
 - Restart the SCU (→ p. 35, §5.5.1).

8.3.3 Time / date displayed is incorrect

Time and date → p. 33, §5.4.1

When the time on the operator panel is wrong after every switch-on:

The battery in the SCU is empty.

Have the battery replaced by SICK Customer Service.

8.4 Malfunctions of the I/O modules

Malfunction	Note ¹
The red LED on the I/O modules goes on	Check firm seating of the green connectors on the rear of the SCU.
The green "running light" is interrupted	Please contact SICK Customer Service.

¹ If fault persists: Contact SICK Customer Service.



More information on the I/O modules → "Modular I/O System" Operating Instructions.

8.5 Checking the operating state of the interferometer

- All 3 LEDs on the power plug at the bottom of the interferometer must be on.
If not:
 - ▶ Is the fuse in the MCS100FT switched on? (→ p. 94, §8.1)
 - ▶ Is the mains switch on the bottom of the interferometer switched on?
 - ▶ Check firm seating of the power plug on the bottom of the interferometer.
- Both LEDs on the socket of the Ethernet cable must light/flash.
If not:
 - ▶ Check firm seating of the Ethernet cable.

8.6 FID does not ignite/burn

- ▶ Ignition of FID: → p. 79, §5.8.8.1

Malfunction	Possible cause	Note
FID does not ignite	Fuel gas supply not available or pressure too low	Ensure correct fuel gas supply.
	Air in the fuel gas line	Ignite repeatedly until the flame is burning. If the FID still does not ignite: Contact SICK Customer Service
FID goes out "repeatedly"	Fuel gas contaminated or pressure varies	Ensure correct fuel gas supply (clean tubes).

MCS100FT

9 Technical Documentation

Dimensions
Technical data

9.1 Approvals

9.1.1 Conformity

The technical design of this device complies with the following EU directives and EN standards:

- EU Directive NSP 2006/95/EC
- EU Directive EMC 2004/108/EC



Applied EN standards:

- EN 61010-1, Safety requirements for electrical equipment for measurement, control and laboratory use
- EN 61326, Electrical equipment for measuring technology, control and laboratory use - EMC requirements

9.1.2 Electrical protection

- Insulation: Protection class 1 according to EN 61010-1.
- Insulation coordination: Measuring category II according to EN61010-1.
- Contamination: The device operates safely in an environment up to degree of contamination 2 according to EN 61010-1 (usual, nonconductive contamination and temporary conductivity by occasional moisture condensation).

9.2

Dimensions

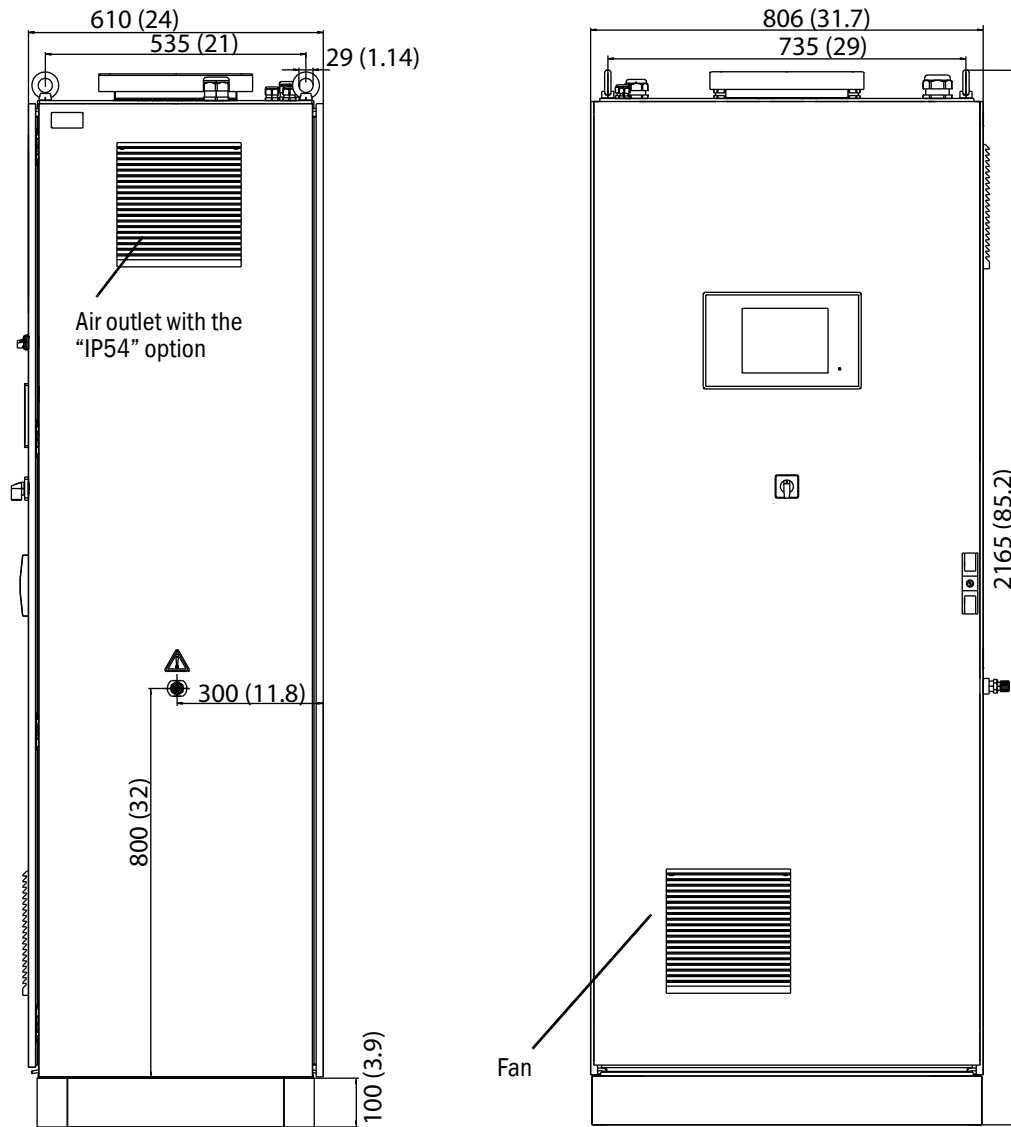

Dimensions in mm (inch)

Subject to change without notice

9.3

Technical data

The Technical Data depend on the equipment on the MCS100FT.

Components	Smallest measuring range	Largest measuring range
CH ₄	0 ... 50 mg/m ³	0 ... 150 mg/m ³
CO	0 ... 75 mg/m ³	0 ... 1500 mg/m ³
HCl	0 ... 15 mg/m ³	0 ... 150 mg/m ³
HF	0 ... 3 mg/m ³	0 ... 10 mg/m ³
NH ₃	0 ... 10 mg/m ³	0 ... 50 mg/m ³
NO	0 ... 200 mg/m ³	0 ... 2000 mg/m ³
N ₂ O	0 ... 50 mg/m ³	0 ... 500 mg/m ³
NO ₂	0 ... 100 mg/m ³	0 ... 500 mg/m ³
SO ₂	0 ... 75 mg/m ³	0 ... 1500 mg/m ³
CO ₂	0 ... 25 % by volume	0 ... 25 % by volume
C ₃ H ₈	0 ... 50 mg/m ³	0 ... 50 mg/m ³
H ₂ O	0 ... 40 % by volume	0 ... 40 % by volume
O ₂	0 ... 21 % by volume	0 ... 21 % by volume
TOC	0 ... 15 mg/m ³	0 ... 500 mg/m ³

The measuring components and measuring ranges can have individual settings → delivered system documentation.

Measured value recording	
Detection limit:	< 2% of full scale reading
Zero drift:	< 3% of full scale reading per maintenance interval For FID-100FT: < 2% of full scale reading per week
Sensitivity drift:	< 3% of full scale reading per maintenance interval For FID-100FT: < 2% of full scale reading per week
Temperature influence:	< 2% of full scale reading / 10 K
Setting time T ₉₀ :	< 200 s For FID: < 45 s
Limit values:	2 limit values as toggle

Device features	
Optical path length of cell:	8.48 m (334 in.)
Laser:	1.5 mW , 633 nm - Laser class 1: Outside interferometer (radiation into cell) - Laser class 3R: Inside interferometer
Device dimensions:	2100 x 800 x 600 (mm) (HxWxD) including 100 mm base 82.7 x 31.5 x 23.6 (in.) (HxWxD) incl. 3.4 in. Base
Weight:	Approx. 260 kg (580 lb)
Enclosure color:	RAL 7035
Sample gas volume, cell:	1.3 l (80 cu.in)
Heating temperature:	
- Sample gas probe	Max. 200°C (390°F)
- Sample gas line	Max. 200°C (390°F)
- Cell	Max. 200°C (390°F)
Sample gas:	
- Flow	Approx. 300 l/h
- Temperature, cell	Max. 200°C (390°F)
- Temperature, sampling point	Max. 1300°C (2370°F)
- Input pressure	90 ... 110 kPa (0.9 ... 1.1 bar)

Ambient conditions	
Ambient temperature:	+5 ... +35 °C (41 ... 95 °F)
Storage temperature:	-20 ... +60 °C (-4 ... 140 °F)
Relative humidity:	Max. 80% (without condensation)
Ambient air pressure:	900 ... 1100 hPa (mbar)
Degree of protection:	IP 43; optional: IP 54

Power input ¹	
- System cabinet	Max. 1000 VA
- Heated sample gas line	95 VA/m (1.5 VA/in.)
- Gas sampling probe	450 VA
- Heated probe tube	450 VA

¹ Feed depends on the application. See system documents.

Gas supply			
Gas	Quality	Input pressure	Flow
Zero gas: IR components/FID:	Instrument air (see below)	300 ± 20 kPa (3 ± 0.2 bar)	Max. 350 l/h
O ₂ analyzer:	1 ... 4% by vol.O ₂ in N ₂ , accuracy ± 2 %	300 ± 20 kPa (3 ± 0.2 bar)	Max. 350 l/h
Span gas: IR components:	Approx. 70% of full scale value	300 ± 20 kPa (3 ± 0.2 bar)	Max. 350 l/h
O ₂ analyzer:	20.96% by vol.O ₂ (ambient air)	300 ± 20 kPa (3 ± 0.2 bar)	Max. 350 l/h
FID-100FT:	Propane in synthetic air. Approx. 80% of full scale reading	300 ± 20 kPa (3 ± 0.2 bar)	Approx. 450 l/h
Instrument air:	Particle size max. 1 µm, oil content max. 0.1 mg/m ³ , pressure dew point max. -30° C (-22° F). When measuring CH ₄ : Instrument air must be free from CH ₄ .	500 ... 700 kPa (5.0 ... 7.0 bar)	Approx. 1500 l/h
Fuel gas for FID:	H ₂ > 5.0	300 ± 20 kPa (3 ± 0.2 bar)	Max. 80 ml/min.
Combustion air for FID:	Instrument air (see above)	---	Max. 30 l/h

Piping	
- Sample gas inlet	DN 4/6
- Ejector induction air	DN 6/8
- Test gas inlet	DN 4/6
- FID-100FT fuel gas inlet	DN 4/6
- Gas outlet	DN 8/10

Operation and interfaces	
Operation:	Password-protected user level
Sequence programs:	Programmable as required
Display and input:	Touch-sensitive 5.7" VGA color monitor (320x240 pixels)
Digital outputs ¹ :	Relay (→ "Modular System I/O" Operating Instructions)
Digital inputs ¹ :	Relay (→ "Modular System I/O" Operating Instructions)
Analog outputs ¹ :	0/4 - 20 mA (→ "Modular System I/O" Operating Instructions)
Analog inputs ¹ :	0/4 - 20 mA (→ "Modular System I/O" Operating Instructions)
Data interfaces:	Optional RS485/422 (Modbus) CAN-Bus (system bus to optional remote I/O interfaces)
Remote control:	Ethernet (Modbus TCP/IP): - Plug: RJ 45 - Type: TCP/IP peer-to-peer. - Method: 10 MBit half-duplex OPC optional

¹ System-dependent configuration → delivered system documentation.
Description → "Modular I/O System" Operating Instructions

Emissions	
Generated condensate:	Approx. 1 l/day (at approx. 25% by vol. H ₂ O in sample gas)

A			
Adjustment	81	Drift (menu)	
- Automatically	55	- FID-100FT	76
- FID-100FT	73, 80	- MCS100FT	61
- Manual	57	Drift check	66
- MCS100FT	61	E	
- O2 Sensor	58	E (classification)	63
Ali	48	Electrical installation	24
Analog inputs (parameter setting)	48	Energy values (menu)	66
Analog outputs (parameter setting)	49	Error messages	
AOi	49	- FID-100FT	77
Approvals	98	- MCS100FT	63
Assembly	20	Ethernet interface	25
		Export (logbook entries)	62
B		F	
Backflush	13	F (classification)	63
Bargraph representation	42	Fan pad	89
Brightness	94	FID analyzer	13, 17
C		FID does not ignite	96
C (classification)	63	Flow plan	18
Components (parameters) (MCS100FT)	59	FTIR spectrometer	13
Connections		Fuses	16, 94
- Electrical	24	G	
- Gas	21	Gas connections	22
Contrast	94	Gas flow plan	18
Controls	32	Gas timing, FID-100FT	73
CTi	44	I	
Cyclic trigger (parameters)	44	Ignition, FID (menu)	79
D		Indicators/displays	32
Date	33, 61	Installation	20 - 21
Device information (menu)	44, 61	Intended use	8
- SCU	44	Interfaces	
Device parameters	53	- Location	16
- FID-100FT	73	- SCU	45
- IR-Cube	53	- Test	45
- MCS100FT	53	Interferometer	16
- Times	53	Interior view	16
Device switch	15	IP address	25, 61
Diagnosis (menu)		L	
- FID-100FT	75	Language	35
- MCS100FT	61	- FID-100FT	71
- SCU	43	Laser class	16
Digital inputs (parameters)	46	Laying the gas lines	21
Digital outputs (parameter setting)	47	LineWriter	42
Dli	46	Logbook	
Dimensions	99	- FID-100FT	62
Display yellow/red	33	- MCS100FT	62
Disposal	85	- SCU	43
Documentation (more detailed)	9		
DOi	47		

Logbook entries			
- FID-100FT	77		
- MCS100FT	63		
- SCU	43		
Logbook, setting parameters			
- MCS100FT	54		
- SCU	45		
Login			
- FID-100FT	51		
- MCS100FT	51		
- SCU	39		
M			
M (classification)	63		
Maintenance (menu)			
- FID-100FT	79		
- MCS100FT	69		
- SCU	45, 49		
Maintenance intervals	88 - 89		
Malfunction	13		
MCS100FT analyzer	13		
Measuring screen, setting parameters (SCU)	45		
Measure (operator panel)	33		
Measured value			
- FID-100FT	70		
- Parameters	60		
Measured value box	41		
Measured value display			
- FID-100FT	71		
Measured value representation	41		
Measuring	40		
- SCU	40		
Measuring screen	33		
- MCS100FT	52		
Menu tree	35		
- FID	38		
- MCS100FT	37		
- SCU	36		
Menus			
- FID-100FT	70		
- MCS100FT	50		
- SCU	39		
Modbus (installation)	26		
O			
O2 Sensor	16		
- Adjustment	58		
- Parameter	58		
O2 sensor	13		
OPC	26		
Operating mode (menu), FID-100FT	75		
Operation Mode Switch	69		
- FID-100FT	79		
- MCS100FT	69		
Operator panel	15		
Oxygen sensor	16		
P			
Parameter			
- FID-100FT	71		
- O2 Sensor	58		
Parameters			
- IR Components	59		
- MCS100FT	52		
- SCU	45		
Password			
- FID-100FT	51		
- MCS100FT	51		
- SCU	39		
Pressure	54		
Product features	12		
Product identification	12		
Purge (with instrument air)	81		
Q			
QAL3	14, 66		
- Check, starting	56		
R			
Reset	35, 49		
Restart	35		
S			
Scope of delivery	20		
SCU (function)	13		
Sensor values	67		
Shutting down	84		
Single adjustment (parameter)	49		
Spare parts	88		
Spectra	68		
Stand-by	13, 95		
Start screen	40		
Start-up	28		
Status field	33		
- Yellow/red	33		
Status indicator	32 - 33		
Storage	84		
Switch off	84		
T			
Technical data	100		
Temperature control (MCS100FT)	54		
Test gas feed	81		
Time	33, 61		
TOC	17		
Transport	21		
Type plate	12		

U

U (classification) 63
Upload parameters
- FID-100FT 51
- MCS100FT 51
- SCU 39

V

Version 44, 61
Visual control 89

X

X (classification) 63

MCS100FT

8011893/V2-1/2012-07 | Subject to change without notice

SICK worldwide

You will find our local subsidiary
or agency at:
www.sick.com

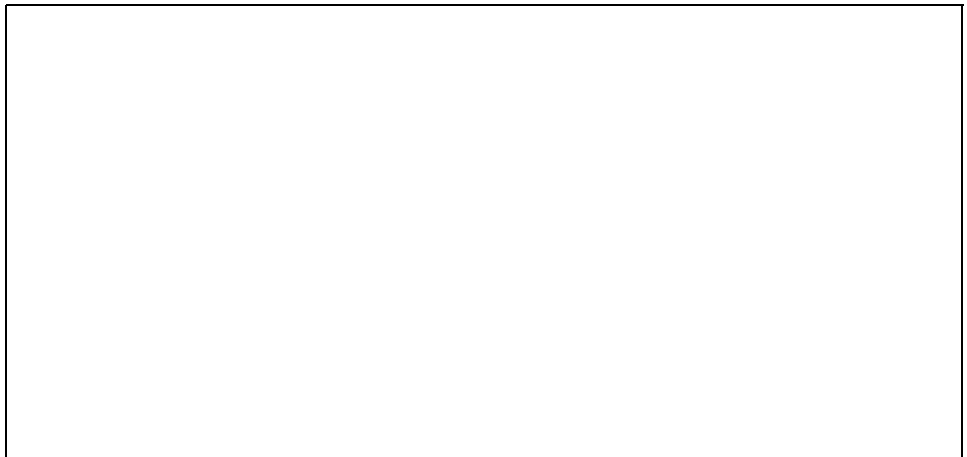

Your local sales and service partner