

# TRANSIC Extractive

OXYGEN MEASUREMENT FOR EVERY APPLICATION

Process Gas Analyzer systems (PGA)

**SICK**  
Sensor Intelligence.

# RELIABLE OXYGEN MEASUREMENT FOR CHALLENGING PROCESS ENVIRONMENTS

Oxygen is a vital elixir of life. Yet in industrial environments, it is often unwelcome. It is highly reactive and can severely compromise process safety and product quality. For instance, it can lead to uncontrolled combustion, to corrosion, and to changes in product properties in foods or chemicals, for example. In such cases, the absence of oxygen is a sign of quality and absolutely essential to ensuring a safe process. TRANSIC Extractive reliably measures oxygen content and can be adapted to the most varied of application conditions – whether you are looking to guarantee safety, prevent corrosion, or ensure product quality.



- ① TRANSIC100LP
- ② Flowmeter
- ③ Needle valve
- ④ Ejector pump
- ⑤ Pressure reducer
- ⑥ Power supply
- ⑦ Mounting panel

## Focused on essentials

With TRANSIC Extractive, SICK provides a modular system for the extractive analysis of oxygen that lends itself to virtually all applications and industry standards. The TRANSIC Extractive process gas analyzer system focuses on the essentials: It impresses thanks to the minimum maintenance it requires, its low operating costs, and components that are perfectly matched to the application in question.

## Proven technology now also available for extractive measurements

TRANSIC Extractive is the answer to all measurement situations where in-situ analysis is not possible: for example, when the measurement point is difficult to access, at temperatures above

80 °C, or when process pressures are high. SICK developed this flexible gas analyzer system for extractive oxygen measurement with conditions such as these in mind. The proven technology of the TRANSIC100LP laser oxygen transmitter can now also be used for extractive measurements.

As a result, TRANSIC Extractive is opening up new possibilities with respect to oxygen measurement. It is now possible to carry out calibrations and operational checks with an additional air supply without dismantling the device, as the procedures can be performed outside the monitored area. If required, TRANSIC Extractive can also keep its eye on several measurement points: Thanks to the programmable measurement point switchover feature, multiple measurement points can be reliably monitored in turn.

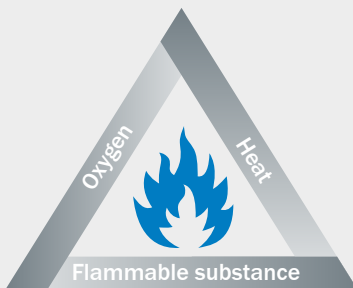

### Oxygen is an ignition source

TRANSIC Extractive is used in many applications where the presence of oxygen gives rise to a risk of explosion. In such cases, the oxygen concentration has to be accurately detected and monitored in order to protect people and plants, and to ensure process safety. The combustion triangle (image to the left) illustrates the three conditions that enable a fire to start: oxygen, heat, and a combustible substance. In many cases, it is not possible to avoid the presence of fuel or the process-related build-up of heat. Therefore, a fire can only be prevented by ensuring the absence of oxygen. It is precisely this that TRANSIC Extractive reliably monitors.



## TRANSIC100LP – THE CORE SYSTEM COMPONENT

TRANSIC Extractive combines the benefits of the TRANSIC100LP transmitter design with the flexibility of an extractive analyzer system. Based on modular design principles, it can be individually configured for every customer. However, one core system component remains unchanged – the TRANSIC100LP laser oxygen transmitter. The system uses state-of-the-art laser technology to deliver precise measurement results even in difficult conditions. As a result, TRANSIC Extractive is the ideal solution for monitoring the O<sub>2</sub> concentration in plants and processes across all industries.

### Laser spectroscopy for precise measurement results

Tunable Diode Laser Spectroscopy is primarily used in high-end gas analyzers and is characterized by its highly selective measurement capability. The oxygen properties are used for O<sub>2</sub> measurement. That means O<sub>2</sub> atoms in the near infrared range are stimulated at specific wavelengths. A laser diode modulates the radiation that provides energy to the O<sub>2</sub> atoms. In the measuring probe, the laser beam hits the O<sub>2</sub> atoms and is weakened according to the concentrations of oxygen. A receiver measures the intensity of the radiation and accurately determines the absorption. One distinct advantage of laser spectroscopy is its insensitivity to possible interference. For O<sub>2</sub> in particular, there are no absorptions of other gases in the area of sampled absorption peaks.

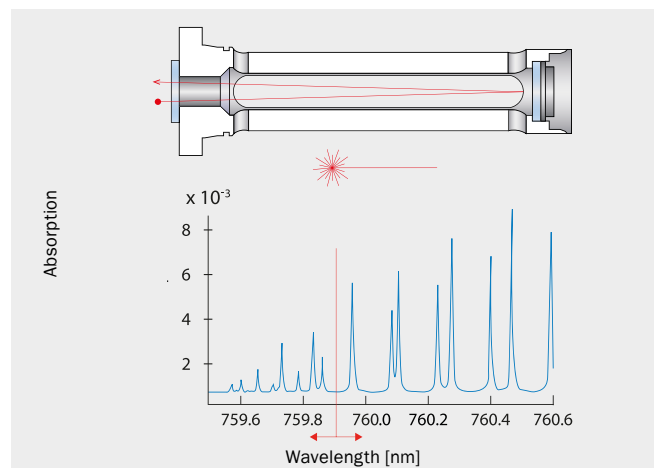

Specific wavelengths at which the TRANSIC100LP measures oxygen selectively

# ONE SYSTEM – MANY APPLICATIONS

As an extractive oxygen measurement device, TRANSIC Extractive is the right choice for a whole host of applications and industries. It reliably fulfills standardized hygiene requirements, offers standardized protection against environmental influences, and is also certified for use in explosion-hazardous areas (to ATEX or NEC 500 and NEC 505).

TRANSIC Extractive is frequently used for the inerting and blanketing of tanks: the airspace in the tank above substances that react with oxygen is filled with inert gas. This effectively protects the content of the tank against contact with oxygen and prevents explosions. In the packaging and food industries too, maintaining a controlled atmosphere is often crucial in ensuring product quality. For example, with modified atmosphere packaging (MAP), food is vacuum-packed, keeping it fresh for longer. While controlled atmosphere storage (CA storage) controls the ripening process of fruit and vegetables when they are transported and stored by reducing the amount of oxygen. Thanks to the system's modular construction, TRANSIC Extractive can be individually adapted to numerous industries and applications.



Inerting and blanketing of tanks



Processing of substances that react with oxygen in process engineering plants



Modified atmosphere packaging



Controlled atmosphere storage

# OXYGEN MEASUREMENT FOR EVERY APPLICATION



## Product description

The TRANSIC Extractive modular analyzer system combines the benefits of the TRANSIC transmitter design with the flexibility of an extractive analyzer system. TRANSIC Extractive is the ideal solution for monitoring the O<sub>2</sub> concentration in plants and processes across all industries. The system uses state-of-

the-art laser spectroscopy to perform reliable measurements even in difficult conditions. As a modular system, it can be adapted to different industry standards and virtually every application, and can even be used in hazardous areas or hygienic areas without any problems.

## At a glance

- Oxygen transmitter based on modern laser spectroscopy (TDLS)
- Compact design adapted to specific application conditions
- Very easy to operate and install
- Can be combined with sample point switching
- Flexible for virtually every application
- Modular extension possible

## Your benefits

- Reliable measurement in difficult measuring conditions and in contaminated gases
- Slim sample conditioning system results in minimal maintenance work
- Can be used in hazardous areas
- Easy to use and install
- Low operating costs



## Additional information

Fields of application . . . . .	7
Detailed technical data . . . . .	7
Ordering information . . . . .	8
Dimensional drawings . . . . .	8

→ [www.sick.com/TRANSIC\\_Extractive](http://www.sick.com/TRANSIC_Extractive)

For more information, simply visit the above link to obtain direct access to technical data, CAD design models, operating instructions, software, application examples, and much more.

## Fields of application

- Inertization of tanks and lines
- Monitoring of O<sub>2</sub> concentration when storing, processing, and packaging food, medicines, and other oxygen-sensitive substances

## Detailed technical data

The exact device specifications and performance data of the product may deviate from the information provided here, and depend on the application in which the product is being used and the relevant customer specifications.

### System TRANSIC Extractive

<b>Measured values</b>	O <sub>2</sub>
<b>Maximum number of measurands</b>	1
<b>Measurement principles</b>	Diode laser spectroscopy (TDLS)
<b>Measuring ranges</b>	O <sub>2</sub> 0 ... 5 Vol.-% / 0 ... 100 Vol.-%
<b>Response time (t<sub>90</sub>)</b>	≤ 10 s
<b>Accuracy</b>	≤ 0.2 Vol.-%
<b>Zero point drift</b>	± 0.1 Vol.-% per year
<b>Process temperature</b>	-20 °C ... +200 °C Other temperatures on request
<b>Process pressure</b>	800 hPa ... 15,000 hPa Higher pressures on request
<b>Ambient temperature</b>	-20 °C ... +60 °C
<b>Storage temperature</b>	-20 °C ... +80 °C
<b>Ex-approvals</b>	<p>IECEX Sender/receiver unit: II 1/2G Ex ib IIB T4 Gb; II 2D Ex ib tb IIIC T85°C Db Measuring probe: II 1/2G Ex op is IIB T4 Ga; II 2D Ex ib tb IIIC T85°C Db Power supply: II 2G Ex e mb [ib] IIB T4 Gb; II 2D Ex tb [ib] IIIC T85°C Db Applies for TRANSIC itself, not necessarily for the entire system</p> <p>ATEX Sender/receiver unit: II 1/2G Ex ib IIB T4 Gb; II 2D Ex ib tb IIIC T85°C Db Measuring probe: II 1/2G Ex op is IIB T4 Ga; II 2D Ex ib tb IIIC T85°C Db Power supply: II 2G Ex e mb [ib] IIB T4 Gb; II 2D Ex tb [ib] IIIC T85°C Db Applies for TRANSIC itself, not necessarily for the entire system</p> <p>NEC/CEC (US/CA) Sender/receiver unit: Class I, Division 2, Group A, B, C, D T4 Measuring probe: Class I, Division 1 + 2, Group A, B, C, D T4 Applies for TRANSIC itself, not necessarily for the entire system</p>
<b>Electrical safety</b>	CE
<b>Enclosure rating</b>	IP66
<b>Analog outputs</b>	<p>1 output: 0/4 ... 20 mA, 500 Ω</p> <p>1 output: 0/4 ... 20 mA, 200 Ω Only for ATEX/IECEX version TRANSIC151LP</p>
<b>Digital outputs</b>	<p>1 relay contact: 30 V AC, 1 A / 60 V DC, 0.5 A</p> <p>1 NAMUR output:</p> <p>Only for ATEX/IECEX version TRANSIC151LP</p>
<b>Interfaces</b>	<p>RS-485 (not for the ATEX/IECEX version)</p> <p>RS-232 (Service interface; not in ATEX/IECEX design)</p> <p>USB (not approved for Ex-applications)</p>
<b>Dimensions (W x H x D)</b>	500 mm x 500 mm x 400 mm (Basic variety, depending on version)
<b>Weight</b>	15 kg ... 30 kg Depending on configuration

<b>Power supply</b>	Voltage	24 V DC TRANSIC151LP: 21.6 ... 26.4 V For ATEX/IECEx versions via TSA151 energy supply, a PELV power supply unit is not necessarily required
	Current consumption	≤ 500 mA TRANSIC151LP: ≤ 240 mA Depending on version
	Power consumption	≤ 6 W TRANSIC151LP: ≤ 5.2 W Depending on version
<b>Corrective functions</b>	Adjustment with ambient air or test gases	
<b>Test functions</b>	Contamination check	

## Ordering information

Our regional sales organization will help you to select the optimum device configuration.

## Dimensional drawings (Dimensions in mm (inch))

System TRANSIC Extractive

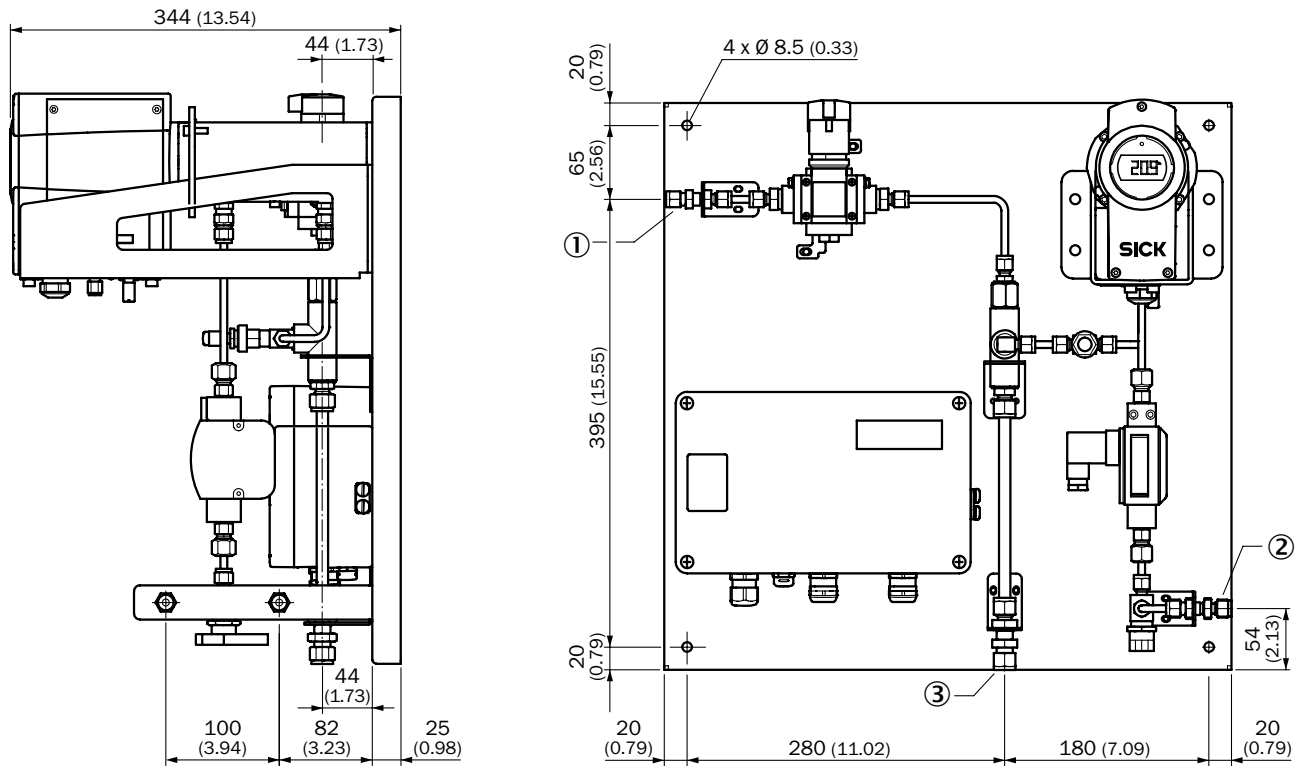







## REGISTER AT WWW.SICK.COM TO TAKE ADVANTAGE OF OUR FOLLOWING SERVICES FOR YOU





- ✔ Access information on net prices and individual discounts.
- ✔ Easily order online and track your delivery.
- ✔ Check your history of all your orders and quotes.
- ✔ Create, save, and share as many wish lists as you want.
- ✔ Use the direct order to quickly order a big amount of products.
- ✔ Check the status of your orders and quotes and get information on status changes by e-mail.
- ✔ Save time by using past orders.
- ✔ Easily export orders and quotes, suited to your systems.



## SERVICES FOR MACHINES AND PLANTS: SICK LifeTime Services

Our comprehensive and versatile LifeTime Services are the perfect addition to the comprehensive range of products from SICK. The services range from product-independent consulting to traditional product services.



- 
**Consulting and design**  
 Safe and professional
- 
**Product and system support**  
 Reliable, fast, and on-site
- 
**Verification and optimization**  
 Safe and regularly inspected
- 
**Upgrade and retrofits**  
 Easy, safe, and economical
- 
**Training and education**  
 Practical, focused, and professional

## SICK AT A GLANCE

SICK is a leading manufacturer of intelligent sensors and sensor solutions for industrial applications. With more than 8,000 employees and over 50 subsidiaries and equity investments as well as numerous agencies worldwide, we are always close to our customers. A unique range of products and services creates the perfect basis for controlling processes securely and efficiently, protecting individuals from accidents and preventing damage to the environment.

We have extensive experience in various industries and understand their processes and requirements. With intelligent sensors, we can deliver exactly what our customers need. In application centers in Europe, Asia and North America, system solutions are tested and optimized in accordance with customer specifications. All this makes us a reliable supplier and development partner.

Comprehensive services round out our offering: SICK LifeTime Services provide support throughout the machine life cycle and ensure safety and productivity.

**For us, that is “Sensor Intelligence.”**

### **Worldwide presence:**

Australia, Austria, Belgium, Brazil, Canada, Chile, China, Czech Republic, Denmark, Finland, France, Germany, Great Britain, Hungary, Hong Kong, India, Israel, Italy, Japan, Malaysia, Mexico, Netherlands, New Zealand, Norway, Poland, Romania, Russia, Singapore, Slovakia, Slovenia, South Africa, South Korea, Spain, Sweden, Switzerland, Taiwan, Thailand, Turkey, United Arab Emirates, USA, Vietnam.

Detailed addresses and further locations → [www.sick.com](http://www.sick.com)