

# General Specifications

GS 77J04A07-02E

Model MA7D  
Distributor  
(Dual-output and Unified Signal Type)

**JUXTA**

## General

The MA7D is a insulated dual-output, plug-in type distributor that is used in combination with a two-wire type transmitter to convert the transmitter's 4 to 20 mA DC signals into isolated 4 to 20 mA DC current or 1 to 5 V DC voltage signals.

- Supports BARD-800.
- Provided with power indicator lamp (RDY).



## Model and Suffix Codes

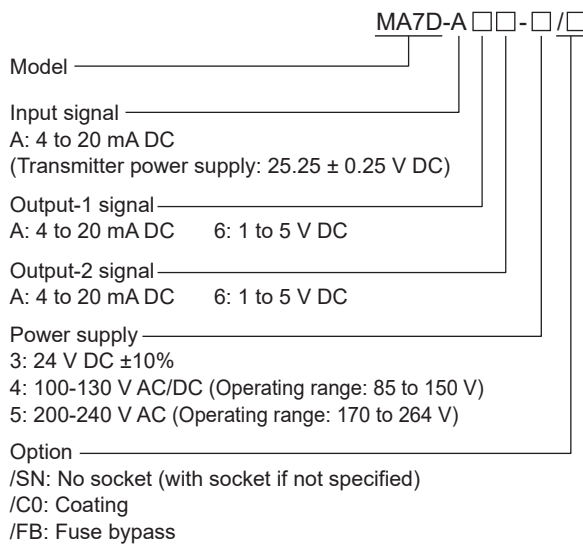

(Note 1) "/CO" option: Polyurethane coating. The "/CO" option does not guaranteed the coating effect though it is expected that the corrosion resistance for electric circuit is reinforced. And it is not able to submit coating test data.

(Note 2) "/FB" option: The primary power supply fuse is deleted, short circuit and ship it.

## Ordering Information

- Model and Suffix Codes: e.g. MA7D-AA6-3

Note: When output signals of 4 to 20 mA and 1 to 5 V DC are required, specify Output-1 as 4 to 20 mA DC because of the allowable load resistance.

## Input/Output Specifications

Input signal: 4 to 20 mA DC signal from two-wire type transmitter  
Input resistance: 250 Ω  
Transmitter power supply: 25.25±0.25 V DC (provided with a current limiter to keep the current between 25 and 35 mA)  
Allowable conductor resistance (RL): Up to [(20 – transmitter's minimum operating voltage) V/0.02 A] Ω  
Maximum allowable input current: 40 mA DC

Output signal: 1 to 5 V DC or 4 to 20 mA DC insulated dual outputs

Output variable range: -6 to 106 % (Both output-1 and output-2)

Allowable load resistance:

Output-1 Range	Allowable Load Resistance	Output-2 Range	Allowable Load Resistance
4 to 20 mA DC	750 Ω maximum	4 to 20 mA DC	350 Ω maximum
1 to 5 V DC	2 kΩ minimum	1 to 5 V DC	2 kΩ minimum

Output resistance: 4 to 20 mA DC; 500 kΩ or more  
1 to 5 V DC; 1 Ω or less

Zero adjustment: -5 to +5%

Span adjustment: 95 to 105%

## Standard Performance

Accuracy rating: ±0.1% of span

Response speed: 150 ms, 63% response (10 to 90%)

Effect of power supply voltage fluctuation: Within the accuracy range of span for power supply voltage fluctuation.

Effect of ambient temperature change: ±0.15 % of span for change of 10 °C

## Power Supply and Isolation

Supply rated voltage range: 24 V DC ±10%

100-130 V AC / DC ≈ 50/60Hz

200-240 V AC ~ 50/60 Hz

Supply input voltage range: 24 V DC ±10%

100-130 V AC / DC (±15%) 50/60Hz

200-240 V AC (-15, +10%) 50/60 Hz

Power consumption: 2.6 W at 24 V DC;

2.5 W at 110 V DC; 4.8 VA at 100 V AC;

6.5 VA at 200 V AC

Insulation resistance: 100 MΩ minimum at 500 V DC

between input, output-1, output-2, power

supply and grounding terminals mutually

Withstanding voltage: 2000 V AC for one minute

between input, (output-1 and output-2),

power supply and grounding terminals

mutually;

1000 V AC for one minute between

output-1 and output-2 terminals

**■ Environmental Conditions**

Temperature: 0 to 50 °C (0 to 40 °C for multiple mounting)  
 Humidity: 5 to 90 % RH (no condensation)  
 Ambient Condition: Avoid installation in such environments as corrosive gas like sulfide hydrogen, dust, sea breeze and direct sunlight.  
 Magnetic field: 400 A/m or less.  
 Continuous vibration (at 5 to 9 Hz) Half amplitude of 3 mm or less (at 9 to 150 Hz) 4.9 m/s<sup>2</sup> or less, 1 oct/min for 90 minutes each in the 3-axis directions.  
 Impact: 98 m/s<sup>2</sup> or less, 11 msec, 3-axis 3 times each in 6 directions.  
 Altitude: 2000 m or less.  
 Warm-up time: At least 30 minutes after power on.

**■ Transport and Storage Conditions**

Ambient temperature: -25 to 70 °C  
 Temperature change rate: 20 °C per hour or less  
 Ambient humidity: 5 to 95 %RH (no condensation)

**■ Mounting and Appearance**

Construction: Compact plug-in type  
 Material: Modified polyphenylene oxide (casing)  
 Mounting method: Wall or DIN rail mounting  
 More than 5 mm interval is required for side-by-side close mounting.  
 Connection method: M3.5 screw terminals  
 External dimensions: 86.5 (H) × 51 (W) × 132 (D) mm (including a socket)  
 Weight: Main unit: 200 g or less  
 Socket: 80 g or less

**■ Accessories**

Spacer: One (used for DIN rail mounting)

**■ Terminal Assignments**

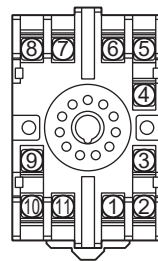

1	Output-1	(+)
2	Output-1	(-)
3	Do not use	
4	Input	(PS+)
5	Input	(-)
6	Input	(COM)
7	Supply	(L+)
8	Supply	(N-)
9	GND	
10	Output-2	(+)
11	Output-2	(-)

**■ Block Diagrams**

(2) Combination with two-wire type transmitter using external power supply

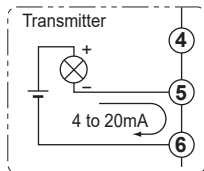

(1) Combination with two-wire type transmitter using internal power supply

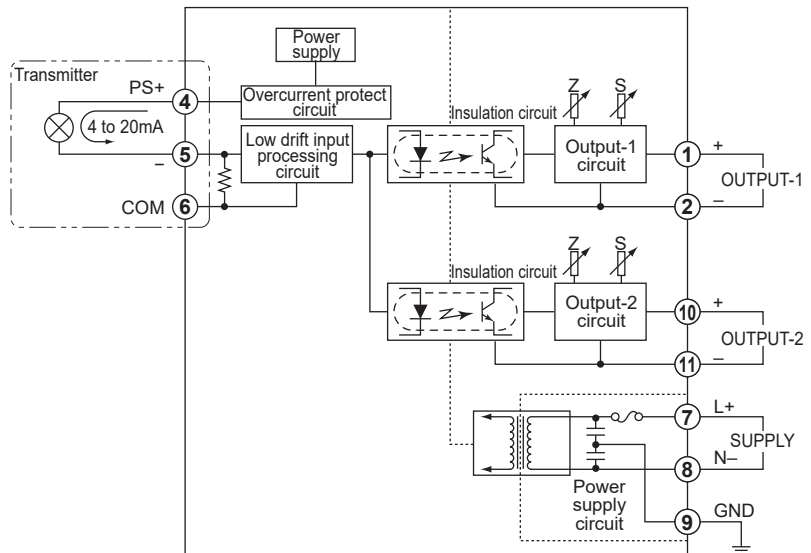

■ External Dimensions

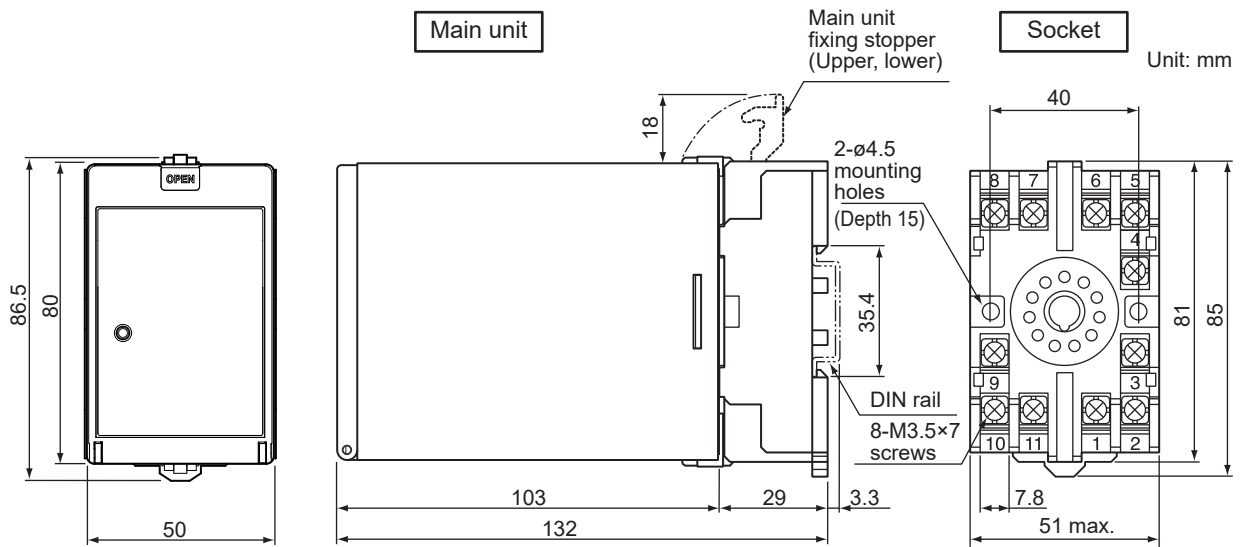

<Mounting Dimensions>

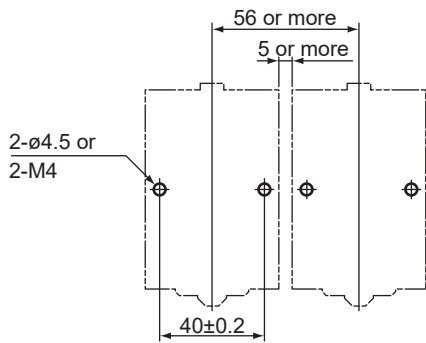

Note:

- When mounting the units close together, leave a space of at least 5 mm between them.
- Use the supplied spacer to keep a space of 5 mm for DIN rail mounting.

Normal Allowable Deviation=  $\pm$  (Value of JIS B 0401-1998 tolerance grade IT18) / 2