

General Specifications

Model PR300 Power and Energy Meter



GS 77C01E01-01E



Overview

This panel-mounted power and energy meter with a large, three-row LED display integrates all the measuring functions required for power management in locations such as factories and buildings into a single unit.

With the objective of working toward the preservation of the global environment by saving energy and performing equipment maintenance, the PR300 is designed to display and output the energy of various types of electrical equipment.

Features

- Saves on cost, wiring, and space
Integrates a wide selection of functions for measuring things like energy (active, regenerative, reactive, and apparent), power (active, regenerative, reactive, and apparent), voltage, current, frequency, and power factor into a single unit.
- Employs a large, three-row LED display
Capable of displaying three-phase current and voltage simultaneously, and the measurement items you assign.
- Analog output function
Equipped with a transducer function for power (active, regenerative, reactive, and apparent), voltage, current, frequency, and power factor (4 to 20 mA DC).
- Demand measurement
Measures the average power and current within a specified period. It also allows you to set up alarm points to output alarms.
- Equipped with a multitude of functions
Enables measurement of the maximum and minimum values of voltage and the maximum value of current, as well as, for example, the use of external digital input to measure energy at arbitrary times.
- Pulse output
Capable of outputting pulses proportional to energy (one measurement item from active, regenerative, reactive, and apparent energy).
- Converts the phase and wire system of an AC power system and an input voltage circuit to a universal format
The PR300 can handle from the single-phase two-wire system and single-phase three-wire system to the three-phase three-wire system and three-phase four-wire system, and also universally cope with input voltage circuits up to 600 V AC.
- Compatible with ANSI 4-inch round form size and DIN 96-square instrument size
The ability to attach and detach JIS/ANSI-mounting kit makes the PR300 compatible with panel cutouts of ANSI 4-inch round form, JIS 110-square instrument size, and DIN 96-square instrument size.
- Standard equipped with an RS-485 communication function and capable of Ethernet communication
- Compatible with overseas requirements
Power line indications A, B, and C provided for overseas use, in addition to R, S, and T

ANSI 4-inch round form size

DIN 96-square instrument size



The ability to attach and detach JIS/ANSI-mounting kit ensures compatibility with two sizes.

Model and Suffix Codes

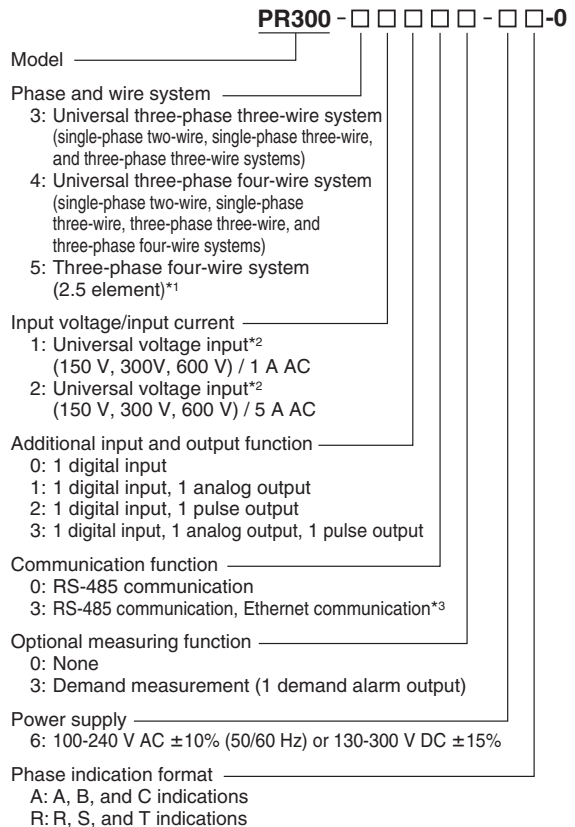

*1 In cases where "Three-phase four-wire system (2.5 element)" is specified, the input current specification of 1 A AC is not applicable. (PR300-51xxx-xx-0 cannot be ordered.)
Can be used only when the voltage is in a state of equilibrium. The phase and wire system cannot be changed.

*2 Set the voltage range (150 V, 300 V, or 600 V) according to the rated input voltage to be measured. (Refer to "Rated Input Voltage" of the Input Specifications on page 6.)

*3 For Ethernet communication, the RS-485 communication interface is exclusively for the Ethernet-serial gateway function.

Ordering Information

Specify the model and suffix codes.

Example: PR300-31000-6A-0

■ Measuring Functions

Measurement item	Single-phase two-wire system	Single-phase three-wire system	Three-phase three-wire system	Three-phase four-wire system	Three-phase four-wire system (2.5 element) *3	Unit and symbol	Remarks		
Active energy (+) *1	✓	✓	✓	✓	✓	kWh, MWh			
Active energy (-) *1	✓	✓	✓	✓	✓	-kWh, -MWh	Regenerative energy		
Reactive energy (+) *1	✓	✓	✓	✓	*4	kvarh, Mvarh	LAG: +		
Reactive energy (-) *1	✓	✓	✓	✓	*4	-kvarh, -Mvarh	LEAD: -		
Apparent energy *1	✓	✓	✓	✓	*4	kVAh, MVAh			
Optional active energy *1	✓	✓	✓	✓	✓	Wh			
Active power	Instantaneous	✓	✓	✓	✓	W, kW, MW			
	Maximum	✓	✓	✓	✓				
	Minimum	✓	✓	✓	✓				
Reactive power	Instantaneous	✓	✓	✓	✓	var, kvar, Mvar			
	Maximum	✓	✓	✓	*4				
	Minimum	✓	✓	✓	✓				
Apparent power	Instantaneous	✓	✓	✓	✓	VA, kVA, MVA			
	Maximum	✓	✓	✓	*4				
	Minimum	✓	✓	✓	✓				
Voltage-1	Instantaneous	✓	✓	✓	✓	V, kV			
	Maximum	✓	✓	✓	✓				
	Minimum	✓	✓	✓	✓				
Voltage-2	Instantaneous	-	✓	-	✓	V, kV			
	Maximum	-	✓	-	✓				
	Minimum	-	✓	-	✓				
Voltage-3	Instantaneous	-	-	✓	✓	V, kV			
	Maximum	-	-	✓	✓				
	Minimum	-	-	✓	✓				
Current-1	Instantaneous	✓	✓	✓	✓	A, kA			
	Maximum	✓	✓	✓	*4				
Current-2	Instantaneous	-	✓	-	✓	A, kA			
	Maximum	-	✓	-	✓				
Current-3	Instantaneous	-	-	✓	✓	A, kA			
	Maximum	-	-	✓	*4				
Frequency	Instantaneous	✓	✓	✓	✓	Hz	Calculated from the voltage-1		
	Maximum	✓	✓	✓	✓				
	Minimum	✓	✓	✓	✓				
Power factor	Instantaneous	✓	✓	✓	✓	COSφ	LAG: + LEAD: -		
	Maximum	✓	✓	✓	✓				
	Minimum	✓	✓	✓	✓				
Demand current *2	Demand current-1	Demand	✓	✓	✓	✓	*4	A, kA	
		Maximum	✓	✓	✓	✓	*4	A, kA	
	Demand current-2	Demand	-	✓	-	✓	-	A, kA	
		Maximum	-	✓	-	✓	-	A, kA	
	Demand current-3	Demand	-	-	✓	✓	*4	A, kA	
		Maximum	-	-	✓	✓	*4	A, kA	
Demand power *2	Demand	✓	✓	✓	✓	✓	W, kW, MW		
	Maximum	✓	✓	✓	✓	✓	W, kW, MW		

*1 Integrated low-cut power can be set for each energy.

Integrated low-cut power: This is a function for not integrating power less than a set value as energy.

The setting range of integrated low-cut power is 0.05 to 20.00% of the rated power (initial value: 0.05%).

*2 Either demand power or demand current can be set as a measurement item.

*3 Can be used only when the voltage is in a state of equilibrium.

*4 Can be measured only when the current is in a state of equilibrium.

✓: Effective
-: Ineffective

● **Optional integrating function**

Power is integrated while a control signal for optional integration is on.

When the control signal is switched from off to on, the optional integrated value indication is reset and integration starts. (The integrated value prior to the reset is held in a register.) The integrated value cannot be guaranteed in the event of a power failure occurring during integration.

● **Demand measurement (when demand measurement is specified)**

The PR300 measures average power or average current within a set demand period.

The maximum demand value for the demand measuring time is held until the power is turned off, remote reset is executed, or the next demand measurement is started.

Item	Setting Range	Resolution	Initial Value	Remarks
Demand power/current	Active power, current	—	Active power	
Demand period	1 to 60 minutes (Demand alarm mask time to 60 minutes)	1 minute	30 minutes	Demand alarm mask time ≤ Demand period
Demand alarm mask time*	1 minute to length of demand period	1 minute	1 minute	
Demand power alarm point	1 to 1000 kW	1 kW	100 kW	When demand power is selected
Demand current alarm point	1 to 1000 A	1 A	100 A	When demand current is selected
Alarm release function	Automatic release and manual release	—	Automatic release	
Data update interval	10 seconds	—	—	

* This is the time from the start of the demand period to the set time in which no judgment is made for the alarm (alarm masked). During the alarm mask time, no maximum demand value is updated and no alarm is output.

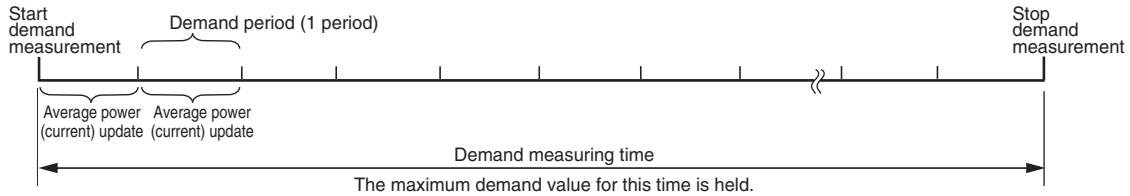



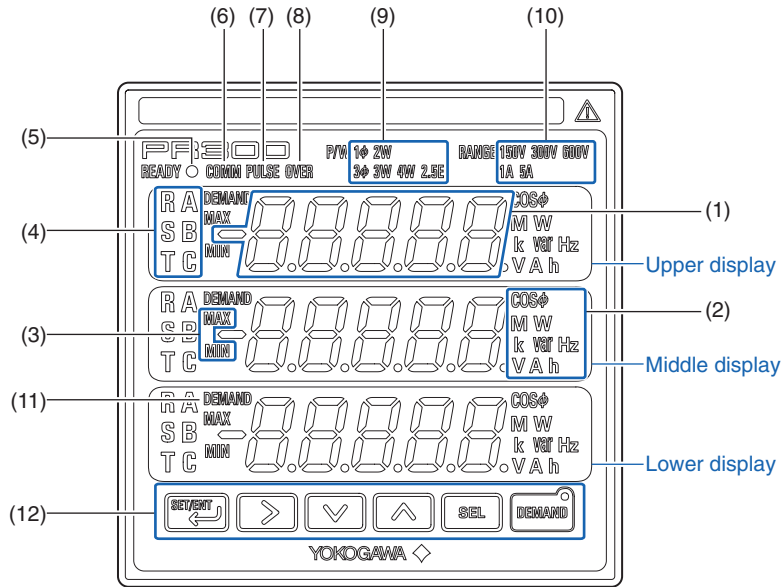















■ Display and Operation Specifications



(1) Measured Value Display	5-digit, 3-row, 7-segment LED display Display color: red																																																																					
	<p>Measured Value display:</p> <table border="1"> <thead> <tr> <th>Measurement Item</th> <th>Display</th> </tr> </thead> <tbody> <tr> <td>Active energy</td> <td>□□□□□ [kWh, MWh] *1</td> </tr> <tr> <td>Reactive energy</td> <td>± □□□□□ [kvarh, Mvarh] *2</td> </tr> <tr> <td>Apparent energy</td> <td>□□□□□ [kVAh, MVAh] *1</td> </tr> <tr> <td>Regenerative energy</td> <td>- □□□□□ [kWh, MWh] *2</td> </tr> <tr> <td>Optional active energy</td> <td>□□□□□ [Wh]</td> </tr> <tr> <td>Active/regenerative power (instantaneous, maximum, and minimum values)</td> <td>□□□□ [W, kW, MW] *2, *3</td> </tr> <tr> <td>Reactive power (instantaneous, maximum, and minimum values)</td> <td>□□□□ [var, kvar, Mvar] *2, *3</td> </tr> <tr> <td>Apparent power (instantaneous, maximum, and minimum values)</td> <td>□□□□ [VA, kVA, MVA] *1, *3</td> </tr> <tr> <td>Voltage (instantaneous, maximum, and minimum values)</td> <td>□□□□ [V, kV] *1, *3</td> </tr> <tr> <td>Current (instantaneous and maximum values)</td> <td>□□□□ [A, kA] *2, *4</td> </tr> <tr> <td>Power factor (instantaneous, maximum, and minimum values)</td> <td>LEAD: d □□□□ [COSφ] *3 LAG: G □□□□ [COSφ]</td> </tr> <tr> <td>Frequency (instantaneous, maximum, and minimum values)</td> <td>□□.□ [Hz] *3</td> </tr> <tr> <td>Demand power</td> <td>□□□□ [W, kW, MW] [DEMAND] *4</td> </tr> <tr> <td>Maximum demand power</td> <td>□□□□ [W, kW, MW] [DEMAND] *4</td> </tr> <tr> <td>Demand current</td> <td>□□□□ [A, kA] [DEMAND] *4</td> </tr> <tr> <td>Maximum demand current</td> <td>□□□□ [A, kA] [DEMAND] *4</td> </tr> </tbody> </table> <p>*1: Without sign, but with a decimal point *2: With a sign and a decimal point ("+" is not indicated). Regenerative power (energy) always shows "-" negative indication. The position of a decimal point differs depending on the primary rated power, VT ratio, and CT ratio. *3: "MAX" lights up for the maximum value and "MIN" lights up for the minimum value. *4: "MAX" lights up for the maximum value.</p> <p>Measured Value screen: Display pattern: The measurement items you want to display are assigned to each of the upper, middle, and lower displays to provide indications using three display rows as one pattern. Up to eight display patterns can be set. The initial values are as shown in the following table. (Combinations other than those shown in the following table are also available if the parameters are set.) Number of display patterns: Can be set in the range of 1 to 8. Pressing the SET/ENT key switches the display from "display pattern-1," "display pattern-2," and so on in order according to the number of patterns set. The initial value is "1" and only display pattern-1 is displayed when this value is set.</p> <table border="1"> <thead> <tr> <th></th> <th>Display Pattern-1</th> <th>Display Pattern-2</th> <th>Display Pattern-3</th> <th>Display Pattern-4</th> <th>Display Pattern-5</th> <th>Display Pattern-6</th> <th>Display Pattern-7</th> <th>Display Pattern-8</th> </tr> </thead> <tbody> <tr> <td>Upper display</td> <td>Current (Phase switch indication)*</td> <td>Active power</td> <td>Active energy</td> <td>Current-1</td> <td>Voltage-1</td> <td>Current (Phase switch indication)*</td> <td>Current (Phase switch indication)*</td> <td>Active power</td> </tr> <tr> <td>Middle display</td> <td>Voltage (Phase switch indication)*</td> <td>Reactive power</td> <td>LEAD reactive energy</td> <td>Current-2</td> <td>Voltage-2</td> <td>Voltage (Phase switch indication)*</td> <td>Active power</td> <td>Maximum demand value</td> </tr> <tr> <td>Lower display</td> <td>Active power</td> <td>Power factor</td> <td>Apparent energy</td> <td>Current-3</td> <td>Voltage-3</td> <td>Frequency</td> <td>Power factor</td> <td>Demand value</td> </tr> </tbody> </table> <p>* The display of current (phase switch indication) is switched between current-1, current-2, and current-3 each time the SEL key is pressed. The display of voltage (phase switch indication) is switched between voltage-1, voltage-2, and voltage-3 each time the SEL key is pressed.</p>	Measurement Item	Display	Active energy	□□□□□ [kWh, MWh] *1	Reactive energy	± □□□□□ [kvarh, Mvarh] *2	Apparent energy	□□□□□ [kVAh, MVAh] *1	Regenerative energy	- □□□□□ [kWh, MWh] *2	Optional active energy	□□□□□ [Wh]	Active/regenerative power (instantaneous, maximum, and minimum values)	□□□□ [W, kW, MW] *2, *3	Reactive power (instantaneous, maximum, and minimum values)	□□□□ [var, kvar, Mvar] *2, *3	Apparent power (instantaneous, maximum, and minimum values)	□□□□ [VA, kVA, MVA] *1, *3	Voltage (instantaneous, maximum, and minimum values)	□□□□ [V, kV] *1, *3	Current (instantaneous and maximum values)	□□□□ [A, kA] *2, *4	Power factor (instantaneous, maximum, and minimum values)	LEAD: d □□□□ [COSφ] *3 LAG: G □□□□ [COSφ]	Frequency (instantaneous, maximum, and minimum values)	□□.□ [Hz] *3	Demand power	□□□□ [W, kW, MW] [DEMAND] *4	Maximum demand power	□□□□ [W, kW, MW] [DEMAND] *4	Demand current	□□□□ [A, kA] [DEMAND] *4	Maximum demand current	□□□□ [A, kA] [DEMAND] *4		Display Pattern-1	Display Pattern-2	Display Pattern-3	Display Pattern-4	Display Pattern-5	Display Pattern-6	Display Pattern-7	Display Pattern-8	Upper display	Current (Phase switch indication)*	Active power	Active energy	Current-1	Voltage-1	Current (Phase switch indication)*	Current (Phase switch indication)*	Active power	Middle display	Voltage (Phase switch indication)*	Reactive power	LEAD reactive energy	Current-2	Voltage-2	Voltage (Phase switch indication)*	Active power	Maximum demand value	Lower display	Active power	Power factor	Apparent energy	Current-3	Voltage-3	Frequency	Power factor
Measurement Item	Display																																																																					
Active energy	□□□□□ [kWh, MWh] *1																																																																					
Reactive energy	± □□□□□ [kvarh, Mvarh] *2																																																																					
Apparent energy	□□□□□ [kVAh, MVAh] *1																																																																					
Regenerative energy	- □□□□□ [kWh, MWh] *2																																																																					
Optional active energy	□□□□□ [Wh]																																																																					
Active/regenerative power (instantaneous, maximum, and minimum values)	□□□□ [W, kW, MW] *2, *3																																																																					
Reactive power (instantaneous, maximum, and minimum values)	□□□□ [var, kvar, Mvar] *2, *3																																																																					
Apparent power (instantaneous, maximum, and minimum values)	□□□□ [VA, kVA, MVA] *1, *3																																																																					
Voltage (instantaneous, maximum, and minimum values)	□□□□ [V, kV] *1, *3																																																																					
Current (instantaneous and maximum values)	□□□□ [A, kA] *2, *4																																																																					
Power factor (instantaneous, maximum, and minimum values)	LEAD: d □□□□ [COSφ] *3 LAG: G □□□□ [COSφ]																																																																					
Frequency (instantaneous, maximum, and minimum values)	□□.□ [Hz] *3																																																																					
Demand power	□□□□ [W, kW, MW] [DEMAND] *4																																																																					
Maximum demand power	□□□□ [W, kW, MW] [DEMAND] *4																																																																					
Demand current	□□□□ [A, kA] [DEMAND] *4																																																																					
Maximum demand current	□□□□ [A, kA] [DEMAND] *4																																																																					
	Display Pattern-1	Display Pattern-2	Display Pattern-3	Display Pattern-4	Display Pattern-5	Display Pattern-6	Display Pattern-7	Display Pattern-8																																																														
Upper display	Current (Phase switch indication)*	Active power	Active energy	Current-1	Voltage-1	Current (Phase switch indication)*	Current (Phase switch indication)*	Active power																																																														
Middle display	Voltage (Phase switch indication)*	Reactive power	LEAD reactive energy	Current-2	Voltage-2	Voltage (Phase switch indication)*	Active power	Maximum demand value																																																														
Lower display	Active power	Power factor	Apparent energy	Current-3	Voltage-3	Frequency	Power factor	Demand value																																																														

<Continued on the following page>

		<p>VT ratio/CT ratio: If the VT ratio and CT ratio are set, input to the PR300 is displayed after converting it to the primary input value before VT or CT. The VT and CT ratios can be set via communication or using the operation keys. VT ratio setting range: 1 to 6000* CT ratio setting range: 0.05 to 32000* * Set the VT ratio and CT ratio so that [secondary rated power] × [VT ratio] × [CT ratio] is smaller than 10 GW.</p>																																										
(2)	Unit Lamps	The relevant unit lamp lights up according to a measurement item and measured value. Display color: red																																										
(3)	MAX and MIN Lamps	Either the MAX or MIN lamp lights up when a maximum or minimum measured value is displayed. Display color: red																																										
(4)	Phase Indication Lamps	Indicate the phase to which the measured value corresponds. (The A, B, and C indications or R, S, and T indications should be specified in accordance with the suffix code.) Display color: red <table border="1" style="margin-left: 20px;"> <thead> <tr> <th>Phase and Wire System</th> <th>Voltage-1</th> <th>Voltage-2</th> <th>Voltage-3</th> <th>Current-1</th> <th>Current-2</th> <th>Current-3</th> </tr> </thead> <tbody> <tr> <td>Single-phase two-wire system</td> <td>A (R)</td> <td>–</td> <td>–</td> <td>A (R)</td> <td>–</td> <td>–</td> </tr> <tr> <td>Single-phase three-wire system</td> <td>A, B (R, S)</td> <td>B, C (S, T)</td> <td>–</td> <td>A (R)</td> <td>C (T)</td> <td>–</td> </tr> <tr> <td>Three-phase three-wire system</td> <td>A, B (R, S)</td> <td>–</td> <td>B, C (S, T)</td> <td>A (R)</td> <td>–</td> <td>C (T)</td> </tr> <tr> <td>Three-phase four-wire system</td> <td>A (R)</td> <td>B (S)</td> <td>C (T)</td> <td>A (R)</td> <td>B (S)</td> <td>C (T)</td> </tr> <tr> <td>Three-phase four-wire system (2.5 element)</td> <td>A (R)</td> <td>–</td> <td>C (T)</td> <td>A (R)*</td> <td>–</td> <td>C (T)*</td> </tr> </tbody> </table> <p>* Can be measured only when the current is in a state of equilibrium.</p>	Phase and Wire System	Voltage-1	Voltage-2	Voltage-3	Current-1	Current-2	Current-3	Single-phase two-wire system	A (R)	–	–	A (R)	–	–	Single-phase three-wire system	A, B (R, S)	B, C (S, T)	–	A (R)	C (T)	–	Three-phase three-wire system	A, B (R, S)	–	B, C (S, T)	A (R)	–	C (T)	Three-phase four-wire system	A (R)	B (S)	C (T)	A (R)	B (S)	C (T)	Three-phase four-wire system (2.5 element)	A (R)	–	C (T)	A (R)*	–	C (T)*
Phase and Wire System	Voltage-1	Voltage-2	Voltage-3	Current-1	Current-2	Current-3																																						
Single-phase two-wire system	A (R)	–	–	A (R)	–	–																																						
Single-phase three-wire system	A, B (R, S)	B, C (S, T)	–	A (R)	C (T)	–																																						
Three-phase three-wire system	A, B (R, S)	–	B, C (S, T)	A (R)	–	C (T)																																						
Three-phase four-wire system	A (R)	B (S)	C (T)	A (R)	B (S)	C (T)																																						
Three-phase four-wire system (2.5 element)	A (R)	–	C (T)	A (R)*	–	C (T)*																																						
(5)	Power Lamp	Lights up when power is supplied. Blinks (4 times/sec) until it returns to normal when the communication error occurs. Display color: green																																										
(6)	Communication Lamp	Blinks during communication (RS-485 or Ethernet). Display color: green																																										
(7)	Pulse Output Lamp	Lights up when output is produced during pulse output, and goes out when no output is produced. Display color: green																																										
(8)	Demand Alarm Lamp	If a demand value exceeds the demand alarm point at a time other than during the alarm mask time, the OVER lamp lights up to indicate the occurrence of an alarm. Display color: red																																										
(9)	Phase and Wire System Lamps	The lamps of the phase and wire system that have been set light up. Display color: green																																										
(10)	Input Range Lamps	The input voltage range (150 V, 300 V, or 600 V) and input current range (1 A or 5 A) that have been set light up. Display color: green																																										
(11)	DEMAND Lamp	Lights up when a demand value is displayed. Display color: red																																										
(12)	Operation Keys	<table border="0" style="width: 100%;"> <tr> <td style="width: 50px; vertical-align: top;"></td> <td>Used to switch measured value display patterns. This key is also used for setting parameters.</td> </tr> <tr> <td style="vertical-align: top;"></td> <td>Used to move the display digit during energy indication. This key is also used for setting parameters.</td> </tr> <tr> <td style="vertical-align: top;"></td> <td>Used to display the maximum or minimum measured value.</td> </tr> <tr> <td style="vertical-align: top;"></td> <td>These keys are also used for setting parameters.</td> </tr> <tr> <td style="vertical-align: top;"></td> <td>Used to switch phase indications when the PR300 displays a voltage or current for which phase indication can be changed. (Phase switch indication is not available for single-phase two-wire system.) This key is also used for setting parameters.</td> </tr> <tr> <td style="vertical-align: top;"></td> <td>Used to start/stop demand measurement. The lamp in the key lights up during demand measurement. Display color: green</td> </tr> </table>		Used to switch measured value display patterns. This key is also used for setting parameters.		Used to move the display digit during energy indication. This key is also used for setting parameters.		Used to display the maximum or minimum measured value.		These keys are also used for setting parameters.		Used to switch phase indications when the PR300 displays a voltage or current for which phase indication can be changed. (Phase switch indication is not available for single-phase two-wire system.) This key is also used for setting parameters.		Used to start/stop demand measurement. The lamp in the key lights up during demand measurement. Display color: green																														
	Used to switch measured value display patterns. This key is also used for setting parameters.																																											
	Used to move the display digit during energy indication. This key is also used for setting parameters.																																											
	Used to display the maximum or minimum measured value.																																											
	These keys are also used for setting parameters.																																											
	Used to switch phase indications when the PR300 displays a voltage or current for which phase indication can be changed. (Phase switch indication is not available for single-phase two-wire system.) This key is also used for setting parameters.																																											
	Used to start/stop demand measurement. The lamp in the key lights up during demand measurement. Display color: green																																											
	Indicator-out Mode Setting	This function turns off LEDs after a certain time elapses, with the exception of the power lamp (LED). The ON/OFF setting of the indicator-out mode function and the wait time before entering the indicator-out mode can be set using the operation keys. (Cannot be set via communication.) Indicator-out mode: ON/OFF (initial value: OFF) Indicator-out mode wait time: 1 to 60 minutes (resolution: 1 minute) (initial value: 10 minutes)																																										
	A/D Sampling Rate, Data Update Interval	A/D sampling rate: 4.8 kHz Internal measurement data: display/communication data is updated at an interval of 1 second or less																																										

Input Specifications

Phase and Wire System	<ul style="list-style-type: none"> • Universal three-phase three-wire system (switch the setting from single-phase two-wire system, single-phase three-wire system, or three-phase three-wire system) • Universal three-phase four-wire system (switch the setting from single-phase two-wire system, single-phase three-wire system, three-phase three-wire system, or three-phase four-wire system) • Three-phase four-wire system (2.5 element) 			
Frequency	45 to 65 Hz			
Rated Input Voltage	Rated Voltage	Voltage Range (Variable)	The primary voltage of VT	Allowable Input Voltage
	120 V	150 V	900 kV	150 V
	240 V	300 V	1800 kV	300 V
	480 V	600 V	3600 kV	600 V
Rated Input Current	Rated Current	Current Range (Fixed)	The primary current of CT	Allowable Input Current
	1 A	1 A	32 kA	1.2 times the current range (continuous) Twice the current range (10 seconds) or 10 times the current range (3 seconds)
	5 A	5 A	160 kA	
Rated Input Power and Measuring Range (When VT and CT are used, their respective secondary values)	• Single-phase two-wire system			
	Input (AC)	Rated Power	Input Measuring Range	Approximate Consumed VA
				Voltage Current
	120 V / 1 A	100 W	-120 to 120 W	0.2 VA
	120 V / 5 A	500 W	-600 to 600 W	
	240 V / 1 A	200 W	-240 to 240 W	0.4 VA
	240 V / 5 A	1000 W	-1200 to 1200 W	
	480 V / 1 A	400 W	-480 to 480 W	0.8 VA
	480 V / 5 A	2000 W	-2400 to 2400 W	
	• Single-phase three-wire system			
Input (AC)	Rated Power	Input Measuring Range	Approximate Consumed VA	
			Voltage Current	
240 V / 1 A	200 W	-240 to 240 W	0.2 VA/ phase	
240 V / 5 A	1000 W	-1200 to 1200 W		
240 V / 1 A	600 W	-720 to 720 W	0.4 VA/ phase	
240 V / 5 A	3000 W	-3600 to 3600 W		
480 V / 1 A	1200 W	-1440 to 1440 W	0.8 VA/ phase	
480 V / 5 A	6000 W	-7200 to 7200 W		
• Three-phase three-wire system				
Input (AC)	Rated Power	Input Measuring Range	Approximate Consumed VA	
			Voltage Current	
120 V / 1 A	200 W	-240 to 240 W	0.2 VA/ phase	
120 V / 5 A	1000 W	-1200 to 1200 W		
240 V / 1 A	400 W	-480 to 480 W	0.4 VA/ phase	
240 V / 5 A	2000 W	-2400 to 2400 W		
480 V / 1 A	800 W	-960 to 960 W	0.8 VA/ phase	
480 V / 5 A	4000 W	-4800 to 4800 W		
• Three-phase four-wire system				
Input (AC)	Rated Power	Input Measuring Range	Approximate Consumed VA	
			Voltage Current	
120 V / 1 A	300 W	-360 to 360 W	0.2 VA/ phase	
120 V / 5 A	1500 W	-1800 to 1800 W		
240 V / 1 A	600 W	-720 to 720 W	0.4 VA/ phase	
240 V / 5 A	3000 W	-3600 to 3600 W		
480 V / 1 A	1200 W	-1440 to 1440 W	0.8 VA/ phase	
480 V / 5 A	6000 W	-7200 to 7200 W		
<p>*Input specification of 1 A AC is not available for 2.5 element.</p> <p>• Input measuring range when VT and CT are used The primary input power (Secondary rated power × 1.2 × VT ratio × CT ratio) is smaller than 10 GW and the value calculated by the following equation is within the input measuring range mentioned above.</p> $\text{Input measuring range (W)} = \frac{\text{Primary input power (W)}}{\text{VT ratio} \times \text{CT ratio}}$				

Digital Input Specifications

For digital input, either the optional integration start/stop or the demand alarm release can be used. If demand measurement is specified for an optional measuring function, digital input enters demand alarm release status. In this case, the optional integration start/stop cannot be used.

Control signal for optional integration

Function	Starts or stops optional integration.
Number of Inputs	1
Input Signal	Voltage signal* ON signal: 4.5 to 25 V DC OFF signal: within ±1 V DC
Minimum ON time	50 ms

* A special order can be placed for no-voltage contact.

Note: Optional integration control is also possible via communication.

Once control is performed by digital input, only digital input-based control is available. Communication-based control is no longer possible until the power is turned off/on or remote reset is executed.

Demand alarm release (when demand measurement is specified)

Function	Cancels demand alarm.
Number of Inputs	1
Input Signal	Voltage signal* ON signal: 4.5 to 25 V DC OFF signal: within ±1 V DC
Minimum ON time	50 ms

* A special order can be placed for no-voltage contact.

■ Analog Output Specifications (When Analog Output is Specified)

Function	Converts measurement data into DC current for output.	
Measurement Item for Output	One item selected from active power, reactive power, apparent power, voltage (1 to 3), current (1 to 3), power factor, and frequency	
Output Signal	4 to 20 mA DC	
Output Accuracy	Measurement accuracy of measurement item for output + (±0.5% of F.S.)	
Allowable Load Resistance	0 to 600 Ω	
Response speed	2 seconds or less (until ±1% of the final value is reached)	
Setting Item	Measurement item for output and the lower and upper limits of scaling. Initial value: active power (W), lower limit of scaling: 50% (0 W), upper limit of scaling: 100% (maximum value of the input measuring range W) Scaling setting condition: upper limit of scaling – lower limit of scaling ≥ 50%	
Setting Range of Lower/Upper Limits of Scaling According to Measurement Item for Output	Active power	–rated power (W) to rated power (W)
	Reactive power	–rated power (var) to rated power (var)
	Apparent power	0 to rated power (VA)
	Voltage (1 to 3)	0 to voltage range (V)
	Current (1 to 3)	0 to current range (A)
	Power factor	(LEAD)0.5 to 1 to (LAG)0.5
	Frequency	45 to 65 (Hz)

■ Pulse Output Specifications (When Pulse Output is Specified)

Function	Outputs pulses proportional to energy.	
Measurement Item for Output	One item selected from active energy, regenerative energy, reactive energy (LEAD, LAG), and apparent energy	
Number of Outputs	1	
Output Signal	Open collector	
Contact Capacity	30 V DC at 200 mA	
Pulse Unit	0.1 to 5000.0 kWh/pulse* (set in 100 Wh increments)	
Setting Item	Measurement item for output, pulse unit, and ON pulse width Initial value: active energy (kWh), pulse unit: 1 kWh/pulse, and ON pulse width: 50 ms	
ON Pulse Width	Represents the ON time of pulses to be output. (Set the pulse width so that the maximum ON pulse width obtained by the following equation is not exceeded.) Within the range of 10 to 1270 ms (set in 10 ms increments) $\text{Maximum ON pulse width (ms)} = \frac{\text{Pulse unit [kWh/pulse]}^* \times 3600 \times 1000^2}{\text{Secondary rated power [W]} \times \text{VT ratio} \times \text{CT ratio} \times 1.2 \times 2}$	

* The units are kvarh/pulse for reactive energy and kVAh/pulse for apparent energy.

■ Demand Alarm Output Specifications (When Demand Measurement is Specified)

Function	Outputs an alarm if the measured demand value exceeds the set demand alarm point.
Output Signal	Open collector
Contact Capacity	30 V DC at 200 mA
Alarm Release Function	Automatic release: Cancels the alarm if demand falls below the demand alarm point when the next measurement is performed. Manual release*: Holds the status of an alarm that occurred once. Cancels the alarm by digital input or the operation key, or via communication.

* Refer to "Demand alarm release" of the Digital Input Specifications.

■ Communication Specifications

● RS-485 communication

Example:

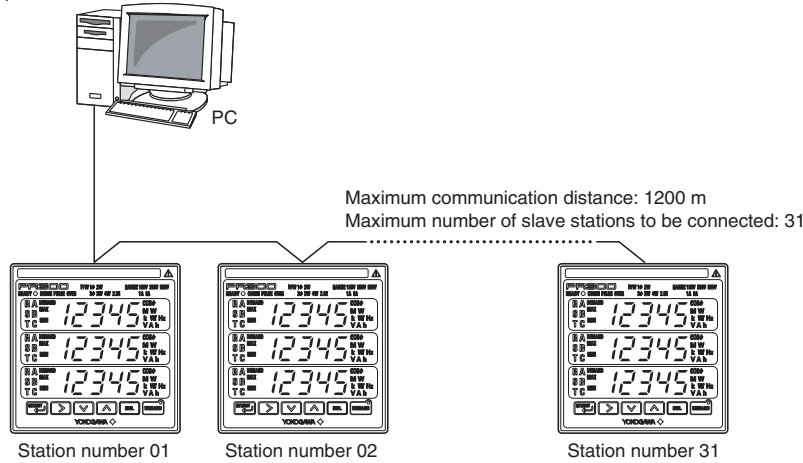

Function	RS-485 communication enables you to use the command/response method to read a variety of measurements and write various settings.	
Protocol	PC link (with checksum, without checksum), Modbus (RTU, ASCII), PR201 original (Note 1)	
Transmission Distance	Approx. 1200 m maximum (when 24 AWG twisted-pair cable is used)	
Connection Method	Multi-drop connection (a maximum of 32 units [including a higher-level device])	
Station Number	01 to 99 (maximum number of units to be connected: 31 [number of units that can be connected to a PC etc.]) (Setting range: 01 to 31 is recommended)	
Transmission Method	Half-duplex communication	
Synchronization Method	Start-stop synchronization	
Baud Rate	19200, 9600, and 2400 bps	
Xon/Xoff Control	None	
Data Format	Data length	8 bits, 7 bits
	Parity	None, even, odd
	Stop bit	1 bit, 2 bits

For details, refer to the user's manual for communications of each device to be connected.
(Note 1) The settings cannot be written.

Example of Connection Diagram

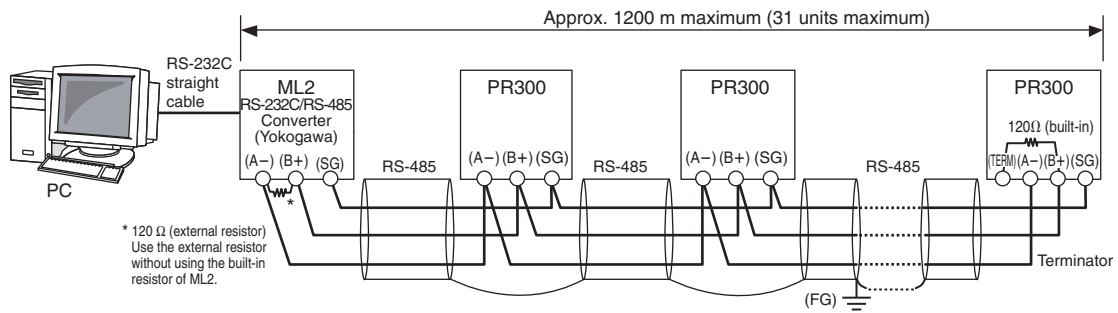

Notes:

The PR300 employs a two-wire system for RS-485 communication.

SG: The SG terminal is connected to match the signal level of the RS-485 communication line.

FG: All shielded wires must be connected and then grounded at one place to provide noise protection for RS-485 communication lines.

● Ethernet communication (when the Ethernet communication function is specified)

Example:

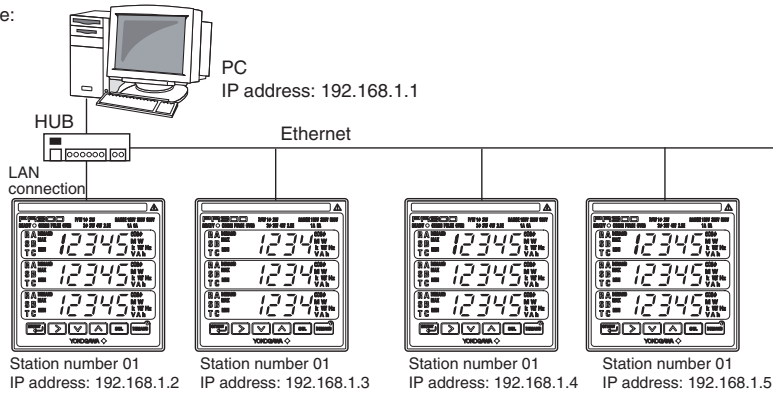

Function	Ethernet communication enables you to use the command/response method to read a variety of measurements and write various settings. The PR300 can be connected to IEEE802.3-compliant networks (10BASE-T/100BASE-TX).		Higher-level device (PC etc.) MODBUS/TCP TCP, UDP IP, ICMP, ARP Ethernet 10BASE-T/100BASE-TX																
Communication Specifications	Protocol	Modbus/TCP																	
	Access Control	CSMA/CD																	
	Baud Rate	10 Mbps/100 Mbps																	
	Maximum Segment Length	100 m (distance between the hub and module)																	
	Maximum Connecting Configuration	Maximum of 4 levels of cascading (for 10BASE-T) or maximum of 2 levels of cascading (for 100BASE-TX) (Number of hubs that can be cascade connected)																	
IP Address	IP addresses can be set using the operation keys on the front of the PR300.																		
Modbus/TCP Function	Code	Function	Description																
	03	Reads data from multiple D registers	Capable of reading data from up to 64 registers continuously.																
	06	Writes data into D register	Capable of writing data into one register.																
	08	Performs loopback test	Capable of performing a communication test.																
	16	Writes data into multiple D registers	Capable of writing data into up to 32 registers continuously.																
Overview of Modbus/TCP Protocol	The structure of Modbus/TCP protocol is as follows: The Simple Protocol Data Unit (PDU) is the same as Modbus/RTU (Modbus protocol via serial communication). The Modbus Application Protocol Header (MBAP Header) is made of the following seven bytes: <table border="1"> <tr> <td>Byte No</td> <td>0</td> <td>1</td> <td>2</td> <td>3</td> <td>4</td> <td>5</td> <td>6</td> </tr> <tr> <td>Description</td> <td>Transaction ID</td> <td>Protocol ID</td> <td>Number of bytes</td> <td>Unit ID</td> <td></td> <td></td> <td></td> </tr> </table> Transaction ID: Set any value for identifying the transaction. The PR300 returns a value received from a higher-level device as a response. Protocol ID: Specify "0" for the Modbus/TCP protocol. Number of bytes: Number of bytes after the unit ID (byte number 6) Unit ID: The PR300 returns a value received from a higher-level device as a response.			Byte No	0	1	2	3	4	5	6	Description	Transaction ID	Protocol ID	Number of bytes	Unit ID			
Byte No	0	1	2	3	4	5	6												
Description	Transaction ID	Protocol ID	Number of bytes	Unit ID															
Ethernet-Serial Gateway Function	The PR300 has an RS-485 communication terminal in addition to an Ethernet communication connector. Modbus/TCP commands received by Ethernet are relayed to the RS-485 terminal. This enables the PR300 to connect to a device with an RS-485 communication function (Modbus/RTU protocol) via a network.																		
	<table border="1"> <tr> <th colspan="2">RS-485 communication</th> </tr> <tr> <td>Protocol</td> <td>Modbus/RTU</td> </tr> <tr> <td>Baud Rate</td> <td>9600 bps</td> </tr> <tr> <td>Parity</td> <td>Even, odd, or none</td> </tr> <tr> <td>Stop Bit</td> <td>1 bit</td> </tr> <tr> <td>Data Length</td> <td>8 bits</td> </tr> </table>	RS-485 communication		Protocol	Modbus/RTU	Baud Rate	9600 bps	Parity	Even, odd, or none	Stop Bit	1 bit	Data Length	8 bits	Example: 					
RS-485 communication																			
Protocol	Modbus/RTU																		
Baud Rate	9600 bps																		
Parity	Even, odd, or none																		
Stop Bit	1 bit																		
Data Length	8 bits																		

For details, refer to the user's manual for communications of each device to be connected.

Note: If Ethernet communication is used, the RS-485 communication interface is used specifically for the Ethernet-serial gateway function. Therefore, it is not possible for a higher-level device such as a PC to access the PR300 via the RS-485 communication interface.

Standard Performance

Accuracy Rating	Active energy/optional active energy (Wh)	±0.5% (EN60687 accuracy: class 0.5 or equivalent)
	Active power (W)	±0.5% of F.S.
	Voltage (V)	±0.25% of F.S. (voltage rms)
	Current (A)	±0.25% of F.S. (current rms)
	Frequency (Hz)	±0.5 Hz
	Demand	±0.5%
Calculation Accuracy	The value is calculated to an accuracy of ±1 digit from the measured value for reactive energy, apparent energy, reactive power, apparent power, power factor or current*. * Current is only for the 2.5 element measurement.	
Backup upon Power Failure	The last integrated values obtained immediately before the power failure are held for active energy, regenerative energy, reactive energy, and apparent energy.	
Insulation Resistance	Between each of the voltage input, current input, power, ground, digital input, pulse output, analog output, RS485 communication output, Ethernet communication output, and alarm output terminals	100 MΩ or more (at 500 V DC)
Withstand Voltage	Between each of the voltage input, current input, power, and ground terminals:	2500 V AC for 1 minute
	Between (the voltage input, current input, power and ground terminals) and the digital input, pulse output, analog output, alarm output, RS-485 communication output, and Ethernet communication output terminals:	2500 V AC for 1 minute
	Between each of the digital input, pulse output, analog output, alarm output, and (RS-485 communication output, Ethernet communication output) terminals:	1000 V AC for 1 minute
	Between the RS-485 communication output, and Ethernet communication output terminals:	500 V AC for 1 minute
Impulse Withstand Voltage	Between all of the voltage input, current input, and power terminals and the ground terminal: Between all of the output and ground terminals and all of the voltage input and current input terminals: 6 kV (1.2/50μs), 10 times for positive and negative	
Effects of Magnetic Field	400 A/m or less Active power: ±0.5% of F.S. Voltage/Current: ±0.25% of F.S.	
Effects of Changes in Ambient Temperature	±0.03%/°C for a temperature change rate of 10°C/h or less (when 0.05 In ≤ I ≤ I max, power factor = 1) ±0.05%/°C for a temperature change rate of 10°C/h or less (when 0.1 In ≤ I ≤ I max, power factor = LAG 0.5) In: rated current, I: present current input	
Effects of Power Supply Voltage Variations	Active power: ±0.25%, Voltage/Current: ±0.125% (for variations within the power supply operating range (when 0.01 In and power factor = 1)) In: rated current	
Effects of Input Frequency	Active power: ±0.25%, Voltage/Current: ±0.125% (for variation of 45 to 65 Hz)	
Power Supply	100-240 V AC ±10% (50/60 Hz) or 130-300 V DC ±15%	
Power Consumption	AC drive: 10 VA maximum, DC drive: 5 W maximum	

Safety and EMC Standards

Safety Standards	Compliant with UL61010-1 CAN/CSA C22.2 No.61010-1-04 (C-UL Listed)		
Measurement category	600V CAT. III		
	Measurement Category	Description	Remarks
	CAT.I	Circuits not directly connected to main power supply	
	CAT.II	Circuits directly connected to low-voltage facility	Home-use equipment, portable tools, etc.
	CAT.III	Circuits in building facilities	Switchboards, circuit breakers, etc.
CAT.IV	Supply sources to low-voltage facilities	Overhead lines, cable systems, etc.	
Installation category	CAT. II Pollution degree: 2		
Rated measurement input	Voltage input: 600V AC (between terminals) Current input: 600V AC (across ground)		
EMC-compliant Standards	KC marking: Electromagnetic wave interference prevention standard, electromagnetic wave protection standard compliance		

■ Environmental Conditions

Normal Operating Conditions	
Warm-up time	At least 30 minutes
Ambient temperature	0 to 50°C (reference temperature: 23 ±2°C)
Temperature change	10°C/h or less
Ambient humidity	20 to 90% RH (no condensation)
Magnetic field	400 A/m or less
Continuous vibration	10 to 60 Hz, 0.035 mm, 75 minutes 60 to 150 Hz, 4.9 m/s ² , 75 minutes
Short-time vibration	14.7 m/s ² for 15 seconds or less
Shock	98 m/s ² or less (for shock time of 11 ms)
Installation	Indoor installation only
Mounting position	Vertical surface mounting only
Installation altitude	2000 m or less
Effects on Operating Conditions	
Effects of ambient temperature	Analog output: ±0.05% of F.S./°C or less
Effects on supply voltage variations	Analog output: ±0.05% of F.S./°C or less
Transport and Storage Conditions	
Temperature	-20 to 70°C
Humidity	5 to 95% RH (no condensation)
Shock and dropping of package	90 cm (provided that an external packing box is used)

■ Initial Settings (Time of Shipment)

The PR300 has the following initial settings at the time of shipment. Settings can be modified after delivery.

	Setting Item	Initial Value
Input	Phase and wire system	Three-phase three-wire system (for three-phase three-wire system) Three-phase four-wire system (for three-phase four-wire system)
	Voltage range	300 V
	VT ratio	1
	CT ratio	1.00
	Integrated low-cut power	0.05 %
Communication	Station number	01
	Protocol	PC link with checksum
	Baud rate	9600 bps
	Parity	None
	Stop bit	1 bit
	Data length	8 bits
	IP address *1	192.168.1.1
	Port number *1	502
Pulse Output *2	Subnet mask *1	255.255.255.0
	Default gateway *1	0.0.0.0
	Measurement item for pulse output	Active energy (kWh)
	Pulse unit	1 kWh/pulse
Analog Output *3	ON pulse width	50 ms
	Measurement item for analog output	Active power (W)
	Lower limit of scaling	50% (0 W)
Demand Measurement *4	Upper limit of scaling	100% (maximum value of the input measuring range W)
	Demand power/current	Active power
	Demand period	30 minutes
	Demand alarm mask time	1 minute
	Demand power alarm point	100 kW
	Demand current alarm point	100 A
Other	Alarm release function	Automatic release
	Indicator-out mode/indicator-out mode wait time	Off/10 minutes

*1 When the Ethernet communication function is specified

*2 When pulse output is specified

*3 When analog output is specified

*4 When demand measurement is specified

■ Power Items and Equations

(V and A are rms values)

Phase and Wire System	Apparent Power	Reactive Power (without using reactive power meter method)	Power Factor
Single-phase two-wire system	$VA = V \times A$	$Q = \sqrt{((VA)^2 - P^2)}$	$\Sigma P / \Sigma VA$ (without using reactive power meter method)
Single-phase three-wire system	$VA_i = V_i \times A_i$ $i = 1, 2$ $\Sigma VA = VA_1 + VA_2$	$Q_i = \sqrt{((VA_i)^2 - P_i^2)}$ $i = 1, 2$ $\Sigma Q = Q_1 + Q_2$	
Three-phase three-wire system	$VA_i = V_i \times A_i$ $i = 1, 3$ $\Sigma VA = \sqrt{3}/2(VA_1 + VA_3)$	$Q_i = \sqrt{((VA_i)^2 - P_i^2)}$ $i = 1, 3$ $\Sigma Q = Q_1 + Q_3$	
Three-phase four-wire system	$VA_i = V_i \times A_i$ $i = 1, 2, 3$ $\Sigma VA = VA_1 + VA_2 + VA_3$	$Q_i = \sqrt{((VA_i)^2 - P_i^2)}$ $i = 1, 2, 3$ $\Sigma Q = Q_1 + Q_2 + Q_3$	
Three-phase four-wire system (2.5 element)	$VA_i = V_i \times A_i$ $i = 1, 3$ $\Sigma VA = \sqrt{3}/2(VA_1 + VA_3)$	$Q_i = \sqrt{3/2} \sqrt{(VA_i)^2 - P_i^2}$ $i = 1, 3$ $\Sigma Q = Q_1 + Q_3$	

* For distorted wave input, there may be differences between the PR300 and a measuring instrument that uses a different measurement principle.

■ Mounting and Shape

Materials	Casing: polycarbonate resin (PC), UL94 V-0 Terminal block: polybutylene terephthalate (PBT), UL94 V-0 Terminal cover: polyamide resin (PA6), UL94 V-2
Mounting Method	Panel mounting (refer to Panel Cutout Dimensions)
Connection Method	M3 screws for terminal connections: analog output, pulse output, demand alarm output, digital input, and RS-485 communication M4 screws for terminal connections: voltage/current input and power supply RJ45 connection: Ethernet communication
External Dimensions (including a terminal cover)	110(H) × 110(W) × 128(D) mm or 96(H) × 96(W) × 126(D) mm
Weight	Approx. 600 g (when the accessories such as mounting bracket are attached)

■ Accessories

JIS/ANSI-mounting kit	1 set
DIN-mounting bracket	2
Dust cover (with a screw)	1
Terminal cover (with screws)	1
Shorting bar (for RS-485 communication termination)	1
Tag number label	2

■ Connection Diagrams

A phase and wire system can be selected by specifying the parameters.

If measurement input does not exceed 600 V AC or 5A AC, direct input without using a VT or CT is possible. Do not ground the input circuit when a VT or CT is not used. Perform wiring for the voltage and current in the same circuit.

● Single-phase two-wire system

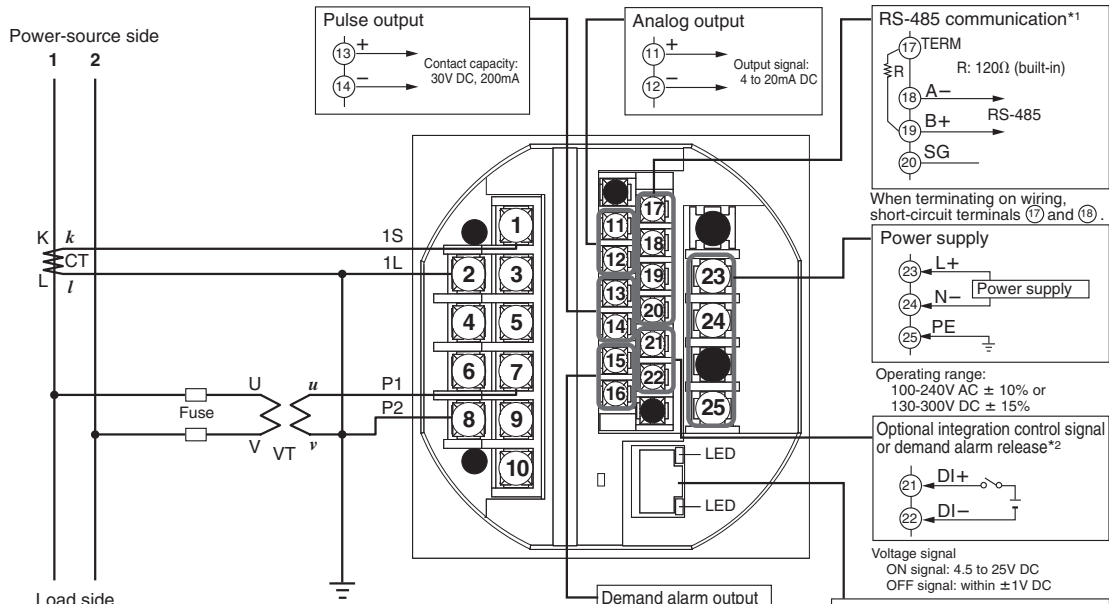

CAUTION
Screws marked with ● are an essential part of the structure. For safety reasons, do not touch them.

- *1: If Ethernet communication is used, the RS-485 communication interface is used specifically for the Ethernet-serial gateway function.
- *2: If demand measurement is specified, the demand alarm release is selected.

Ethernet communication
RJ45 connector
10BASE-T/100BASE-TX

Link LED (top)		Active LED (bottom)	
Color	Description	Color	Description
Off	Stopped	Off	Stopped
Orange	10Mbps	Orange	Half duplex
Green	100Mbps	Green	Full duplex

Switching between 10BASE-T and 100BASE-TX takes place automatically.
Switching between half duplex and full duplex takes place automatically.

● Single-phase three-wire system

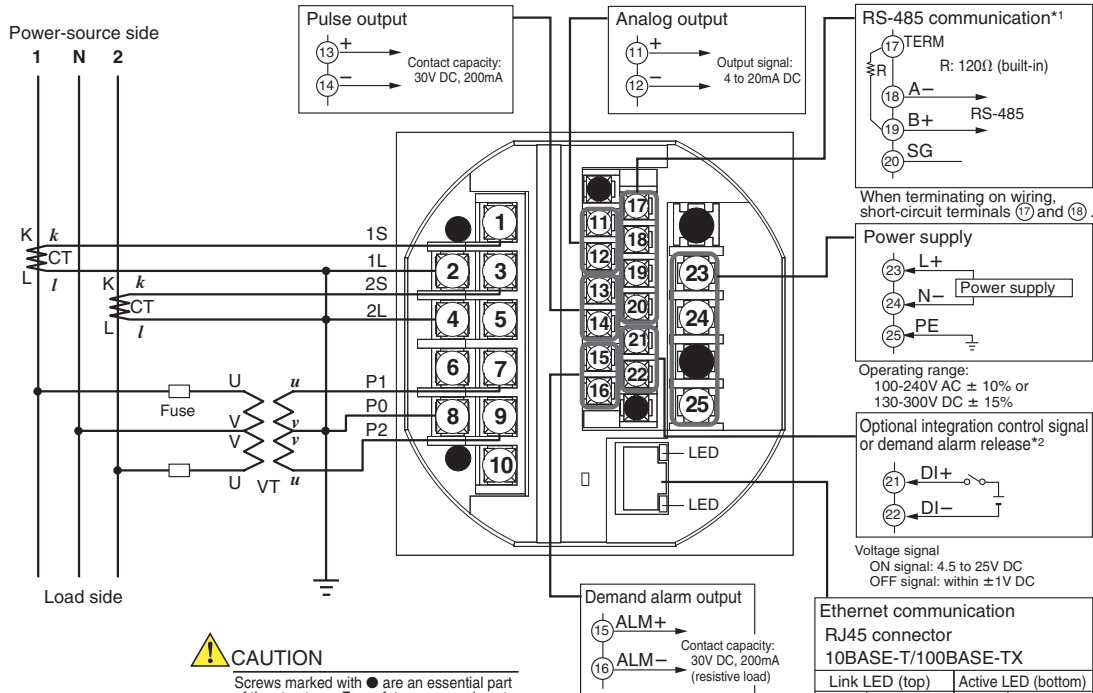

CAUTION
Screws marked with ● are an essential part of the structure. For safety reasons, do not touch them.

*1: If Ethernet communication is used, the RS-485 communication interface is used specifically for the Ethernet-serial gateway function.
*2: If demand measurement is specified, the demand alarm release is selected.

Ethernet communication
RJ45 connector
10BASE-T/100BASE-TX

Link LED (top)		Active LED (bottom)	
Color	Description	Color	Description
Off	Stopped	Off	Stopped
Orange	10Mbps	Orange	Half duplex
Green	100Mbps	Green	Full duplex

Switching between 10BASE-T and 100BASE-TX takes place automatically.
Switching between half duplex and full duplex takes place automatically.

● Three-phase three-wire system

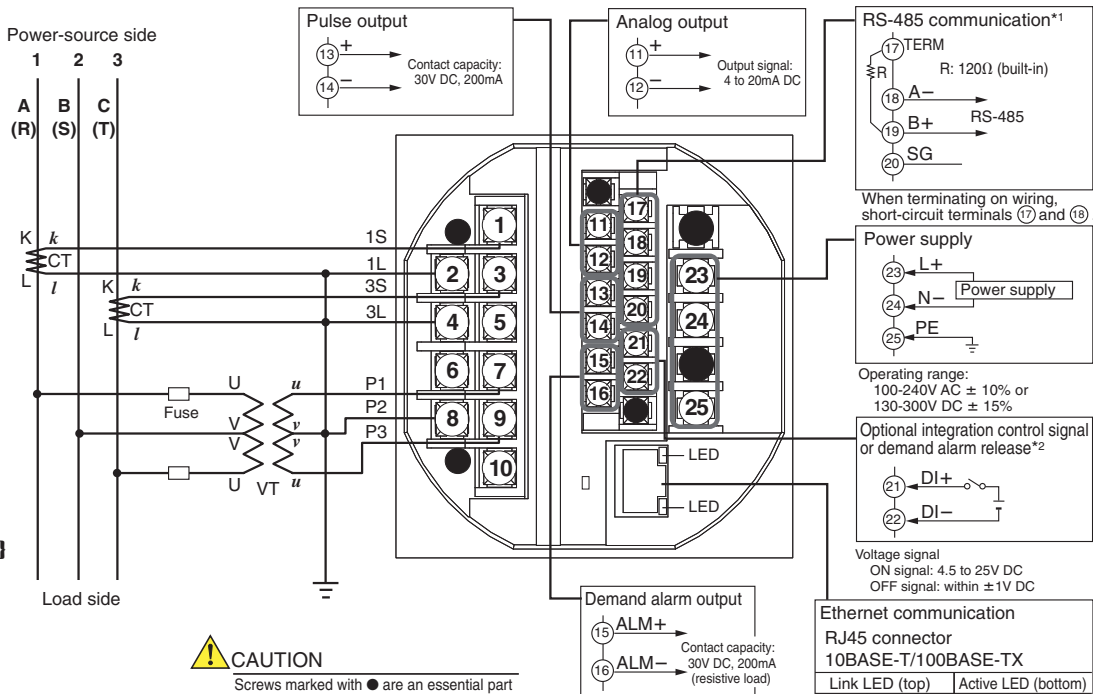

CAUTION
Screws marked with ● are an essential part of the structure. For safety reasons, do not touch them.

*1: If Ethernet communication is used, the RS-485 communication interface is used specifically for the Ethernet-serial gateway function.
*2: If demand measurement is specified, the demand alarm release is selected.

Ethernet communication
RJ45 connector
10BASE-T/100BASE-TX

Link LED (top)		Active LED (bottom)	
Color	Description	Color	Description
Off	Stopped	Off	Stopped
Orange	10Mbps	Orange	Half duplex
Green	100Mbps	Green	Full duplex

Switching between 10BASE-T and 100BASE-TX takes place automatically.
Switching between half duplex and full duplex takes place automatically.

● Three-phase four-wire system

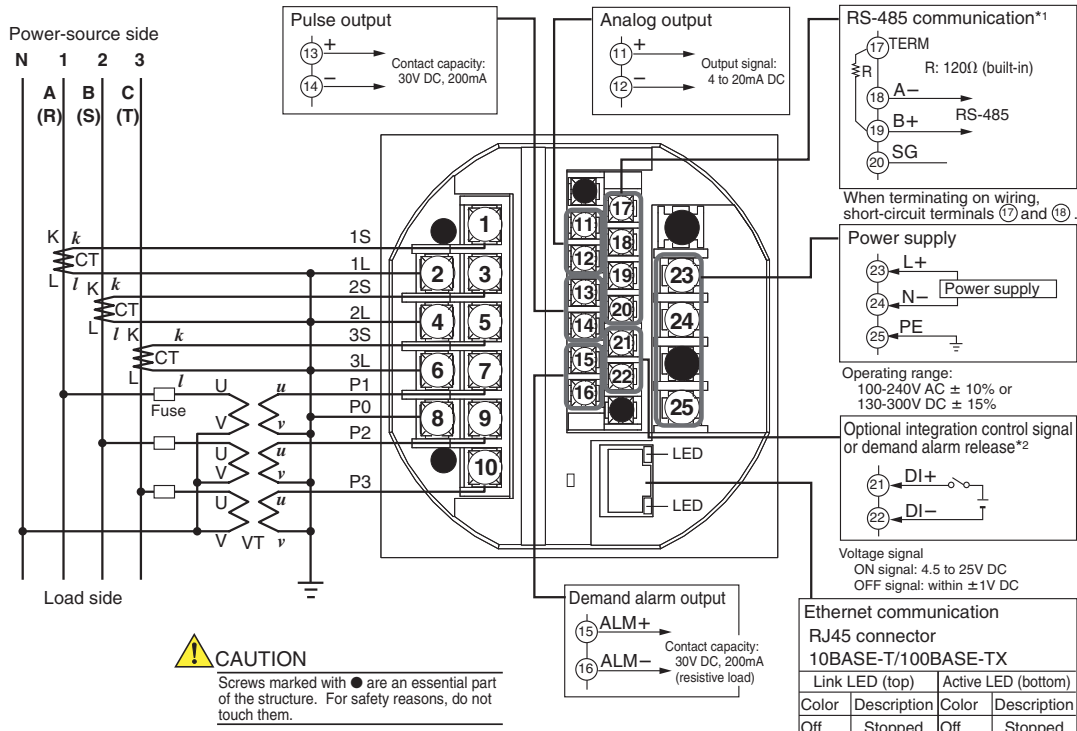

*1: If Ethernet communication is used, the RS-485 communication interface is used specifically for the Ethernet-serial gateway function.
*2: If demand measurement is specified, the demand alarm release is selected.

Ethernet communication
RJ45 connector
10BASE-T/100BASE-TX

Link LED (top)		Active LED (bottom)	
Color	Description	Color	Description
Off	Stopped	Off	Stopped
Orange	10Mbps	Orange	Half duplex
Green	100Mbps	Green	Full duplex

Switching between 10BASE-T and 100BASE-TX takes place automatically.
Switching between half duplex and full duplex takes place automatically.

● Three-phase four-wire system (2.5 element)

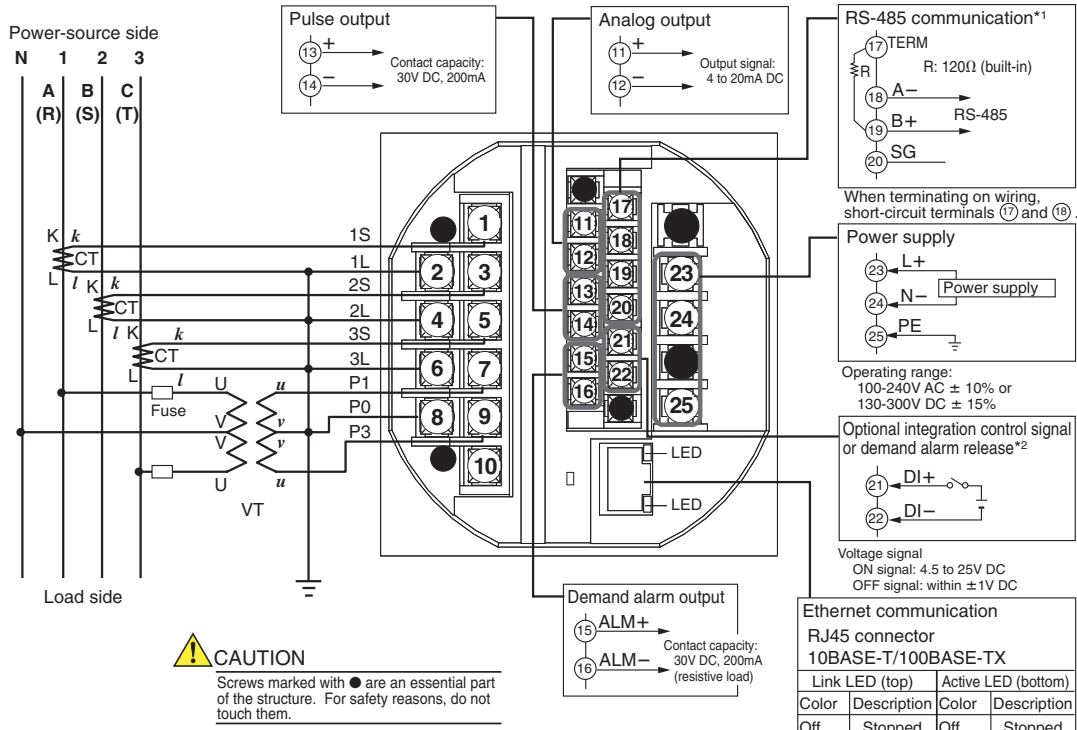

*1: If Ethernet communication is used, the RS-485 communication interface is used specifically for the Ethernet-serial gateway function.
*2: If demand measurement is specified, the demand alarm release is selected.

Ethernet communication
RJ45 connector
10BASE-T/100BASE-TX

Link LED (top)		Active LED (bottom)	
Color	Description	Color	Description
Off	Stopped	Off	Stopped
Orange	10Mbps	Orange	Half duplex
Green	100Mbps	Green	Full duplex

Switching between 10BASE-T and 100BASE-TX takes place automatically.
Switching between half duplex and full duplex takes place automatically.

● DIN 96-square instrument size

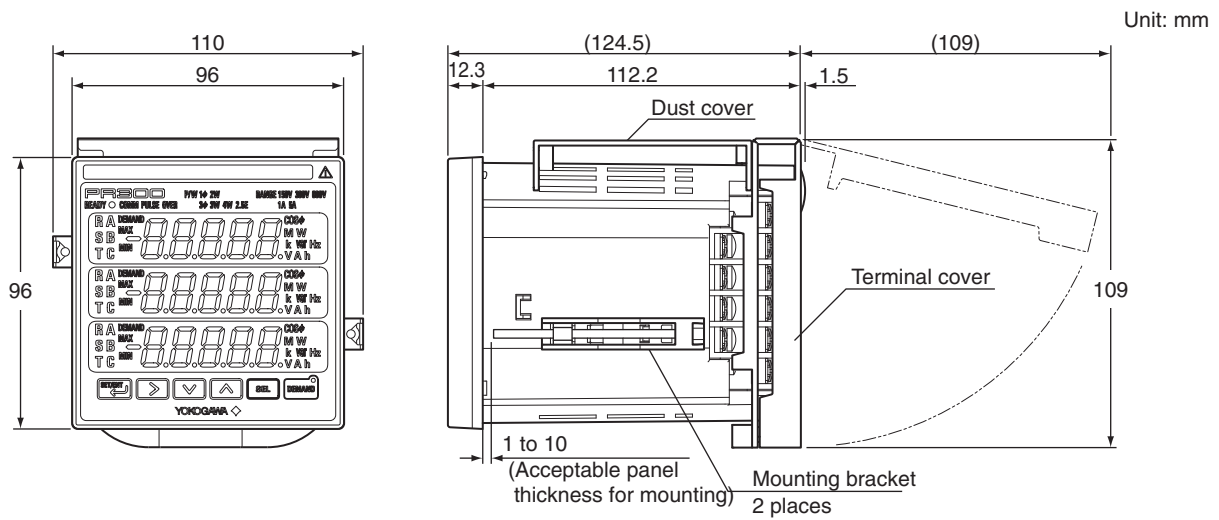

<Panel Cutout Dimensions>

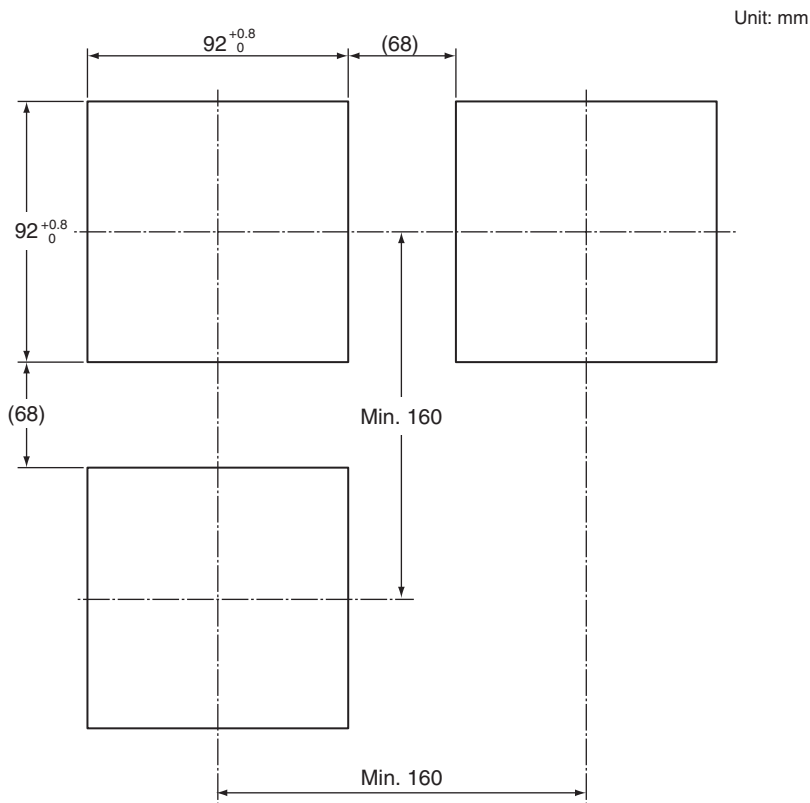

Normal Allowable Deviation=±(Value of JIS B 0401-1999 tolerance grade IT18)/2