

IM JF70-01E

## 1. INSPECTION

This instrument has been thoroughly tested at the factory before shipment. When you receive it, visually inspect it for damage and check the accessories.

### 1.1 Model number and specification check

Check to see the model number and specifications on the nameplate attached to the front cover of the transmitter are as ordered.

### 1.2 Contents of the instruction manual

This instruction manual provides instructions on mounting and maintenance of the instrument.

## 2. GENERAL

This instrument receives contact pulse or voltage pulse signals from the field and convert them into set pulse rate and isolated transistor pulse contact.

Accessories: Mounting block	2
Tag number label	1
Mounting screw M4	2

## 3. MOUNTING METHOD

JUXTA signal conditioners can be mounted on racks, walls or DIN rails.

### 3.1 Rack mounting

Use panel (FRK-16) and install it on an angle as shown in Fig.1. This is a convenient method for high density mounting on 19-inch rack panel.

### 3.2 Wall mounting

Use panel (FRK-16) to install the instrument on the wall as shown in Fig. 2 or directly mount it on the wall.

### 3.3 DIN rail mounting

Insert DIN rail into the upper section of the DIN rail groove on the rear of the instrument and lock the rail in position by using the slide lock at the base of the instrument as shown in Figs. 3 and 4.

### 3.4 Angle mounting

See Fig.5 for dimension of angle mounting.

### 3.5 Mounting block installation and removal

Insert a mounting block into groove of the instrument and slide it until it locks in position by the stopper as shown in Fig.6. To remove it, use screwdriver (-) to lift the stopper and slide the mounting block along the groove.

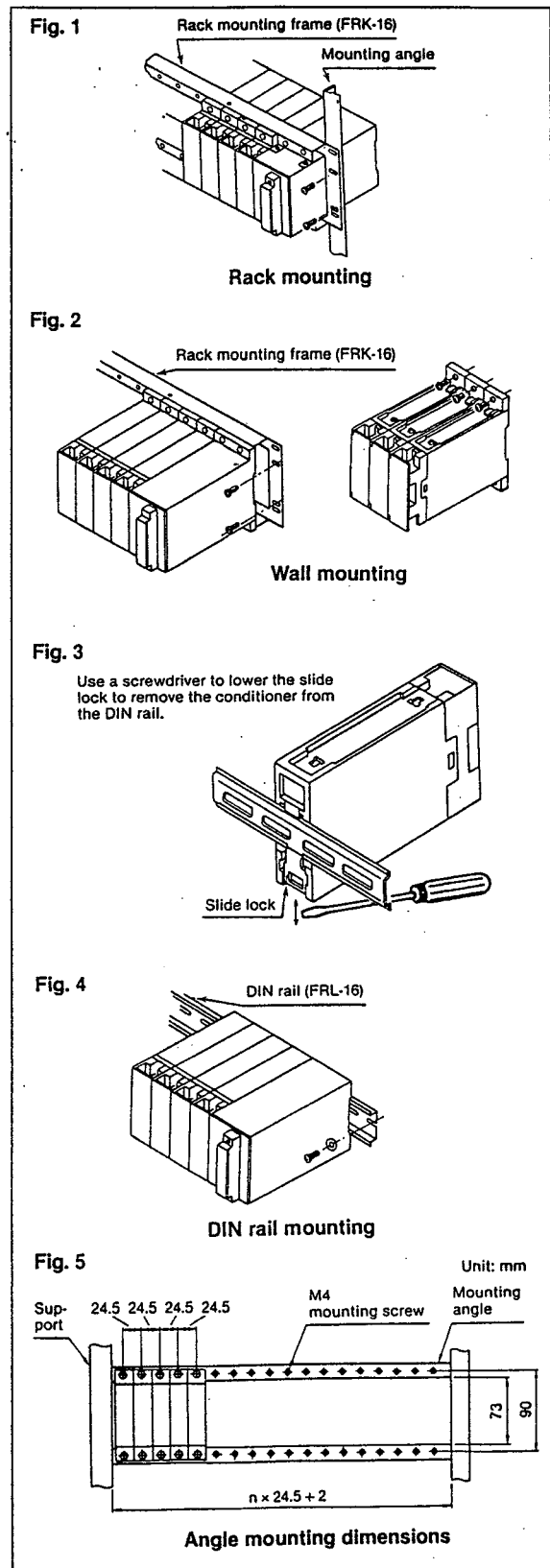

#### 4. CALCULATION AND SETTING OF PULSE RATE

##### 4.1 Calculation of pulse rate

This instrument converts 0~Fin,00 Hz input pulse into pulse rate and gains 0~Fout,00 Hz output pulse of ON pulse width 30ms when

$$Fin,00 \leq 10\text{kHz} \quad (\text{Specify } Fin,00 \text{ when ordering})$$

$$Fout,00 \leq 16.6\text{Hz} \quad (\text{Specify } Fout,00 \text{ when ordering})$$

Pulse rate can be obtained by putting Fin,00 and Fout,00 into formula (1) below:

$$\text{Pulse rate} = \frac{Fout,00}{Fin,00} \text{ ---(1)}$$

Check to see the obtained pulse rate meets with the following conditions:

To make duty less than 50% of output ON pulse width 30ms, output frequency (Fout,00) will be less than 16.6Hz. To satisfy with this condition, setting of pulse rate against input frequency (Fin,00) is limited as shown in Fig.8. Change of output ON pulse width is treated by special order. However, when change is made on output ON pulse width, input frequency (Fin,00) is also changed.

##### 4.2 Pulse rate setting

Set pulse rate obtained by the formula (1) on switches SW51~SW54. (See Fig.9)

#### 5. MAINTENANCE

(Caution)

Carry out the following calibration after warm-up the instrument for more than 5 minutes.

##### 5.1 Equipment required for calibration

- Pulse Generator 1  
(Yokogawa-Hewlett-Packard 8116A or equivalent)
- Counter 1  
(Yokogawa-Hewlett-Packard 5334B or equivalent)
- Resistor and Battery  
(25Ω, J, 2W or more resistor and 6V battery) 1 each

##### 5.2 Calibration

Signal transmission characteristic check  
Connect pulse generator, counter and resistor as shown in Fig. 11. Generate rectangular pulse at optional frequency within standard specifications by pulse generator and measure its value by the counter (oscilloscope). Then connect the counter to terminals No.4 and 5. Check that the pulse frequency corresponding to the input is output. In case use of oscilloscope, output pulse is shaped in rectangle.

Note:

When power of FP4P is turned on/off, one pulse may be counted by the pulse input device which connects to the FP4P.

Fig. 6

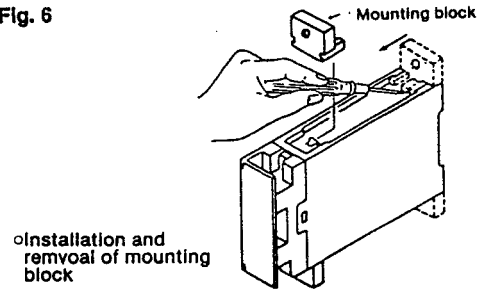
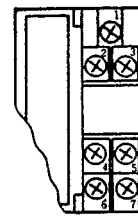

Fig. 7



Terminal	
1	INPUT NC
2	INPUT +
3	INPUT -
4	OUTPUT +
5	OUTPUT -
6	SUPPLY +
7	SUPPLY -

Terminal arrangement

Fig. 8

Input Frequency (Fin,00)	Pulse Rate
0~16.6Hz	No limit
16.7~33.3Hz	0.4000 以下
33.4~83.3Hz	0.2000 以下
83.4~166Hz	0.1000 以下
167~333Hz	0.0400 以下
334~833Hz	0.0200 以下
0.834~1.66 kHz	0.0100 以下
1.67~3.33 kHz	0.0040 以下
3.34~8.33 kHz	0.0020 以下
8.34~10.0 kHz	0.0010 以下

Fig. 9

(Example)

$$\text{Pulse Rate} = 0.1234$$

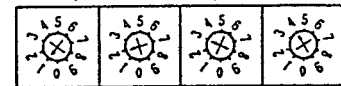

Fig. 10

Pulse signal

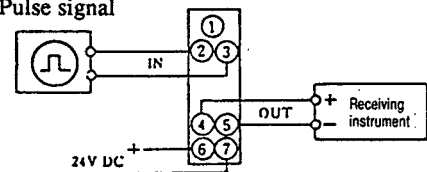
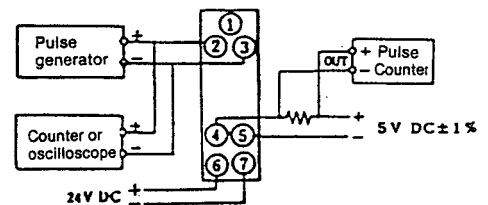

Fig. 11



Calibration equipment wiring

Subject to change without notice for grade up quality and performance.