**User's
Manual**

**AQ1300/AQ1301 ETHERNET
Multi Field Tester
Communication Interface**

Thank you for purchasing the AQ1300/AQ1301 ETHERNET Multi Field Tester. This Communication Interface User's Manual describes the functions and commands of the following communication interfaces.

- USB Interface
- Ethernet Interface

To ensure correct use, please read this manual thoroughly before operation. Keep this manual in a safe place for quick reference in the event that a question arises. This manual is one of four AQ1300/AQ1301 manuals. Please read all the manuals.

Manual Title	Manual No.	Description
AQ1300/AQ1301 ETHERNET Multi Field Tester Operation Guide	IM AQ1300-02EN	This guide focuses on the handling precautions, basic operations, and specifications of the AQ1300/AQ1301.
AQ1300/AQ1301 ETHERNET Multi Field Tester User's Manual (included in CD)	IM AQ1300-01EN	This manual. It explains all the AQ1300/AQ1301 features and how to use them.
AQ1300/AQ1301 ETHERNET Multi Field Tester Communication Interface User's Manual (included in CD)	IM AQ1300-17EN	The manual explains the AQ1300 communication interface features and instructions on how to use them.
AQ1300 MFT10GbE Setup Software User's Manual (included in CD)	IM AQ1300-61EN	This manual explains how to use a PC to create AQ1300/AQ1301 setup files, display result files, and generate CSV files.

Notes

- **This manual (IM AQ1300-17EN 2nd edition) applies to AQ1300/AQ1301 ETHERNET Multi Field Testers with firmware version R1.09.01.001 and later.**

If you are using an older version, you will not be able to use the features described in this manual. Check the firmware version of your product on the product information screen. For information on how to view the product information, see section 14.4 in the user's manual, IM AQ1300-01EN. For information on how to update the firmware, see section 14.5 in the user's manual, IM AQ1300-01EN.

- The contents of this manual are subject to change without prior notice as a result of continuing improvements to the instrument's performance and functionality. The figures given in this manual may differ from those that actually appear on your screen.
- Every effort has been made in the preparation of this manual to ensure the accuracy of its contents. However, should you have any questions or find any errors, please contact your nearest YOKOGAWA dealer.
- Copying or reproducing all or any part of the content of this manual without the permission of YOKOGAWA is strictly prohibited.
- The TCP/IP software of this product and the documents concerning it have been developed/created by YOKOGAWA based on the BSD Networking Software, Release 1 that has been licensed from the Regents of the University of California.

Trademarks

- Microsoft, Windows, Windows XP and Windows Vista are either registered trademarks or trademarks of Microsoft Corporation in the United States and/or other countries.
- Adobe, Acrobat, and PostScript are either registered trademarks or trademarks of Adobe Systems Incorporated.
- In this manual, the ® and TM symbols do not accompany their respective registered trademark or trademark names.
- Other company and product names are registered trademarks or trademarks of their respective holders.

Revisions

- 1st Edition: March 2013
- 2nd Edition: September 2015
- 3rd Edition: October 2017

USB Interface and Ethernet Interface

- The items below are needed on the PC to use the communication functions via the USB interface.
- The communication library (TMCTL)
- USB driver
- The item below is needed on the PC to use the communication functions via the Ethernet interface.
- The communication library (TMCTL)

The library and driver above can be downloaded from the following Web page.

<http://www.yokogawa.com/tm/>

How to Use this Manual

Structure of the Manual

This User's Manual consists of the following sections:

Chapter 1 USB Interface

Describes the functions and specifications of the USB interface used to control the AQ1300/AQ1301 ETHERNET Multi Field Tester from a PC.

Chapter 2 Ethernet Interface/Telnet

Describes the functions and specifications of the Ethernet interface.

Chapter 3 Before Programming

Describes the syntax used to transmit commands.

Chapter 4 Commands

Describes each command that is available.

Chapter 5 Condition Register / Output Queue and Error Queue

Describes the register and queues.

Appendix

Explains the support for AQ1300/AQ1301 error cord.

Conventions Used in This Manual

Notations Used in the Procedural Explanations

On pages that describe the operating procedures in each chapter, the following notations are used to distinguish the procedure from their explanations.

Procedure This subsection contains the operating procedure used to carry out the function described in the current section. The procedures are written with inexperienced users in mind; experienced users may not need to carry out all the steps.

Explanation This subsection describes the setup parameters and the limitations on the procedures.

Note Calls attention to information that is important for proper operation of the instrument.

Terms Used in Explanations of Procedures

Panel Keys and Soft Keys

Bold characters used in the procedural explanations indicate characters that are marked on the panel keys or the characters of the soft keys displayed on the screen menu.

Units

k: Denotes "1000." Example: 400km

K: Denotes "1024." Example: 459 KB (file data size)

Symbols Used in Syntax Descriptions

Symbols which are used in the syntax descriptions in Chapter 4 are shown below.

These symbols are referred to as BNF notation (Backus-Naur Form).

For detailed information, see section 3.4, "Data."

Symbol	Description	Example	Example of Input
<x>	Defined value	SET:M<x> <x> = 1,2,3	-> SET:M2
{}	One of the options in {} is selected.	LMTechnique {LSA TPA}	-> LMTechnique TPA
	Exclusive OR		

Contents

How to Use this Manual	iii
Conventions Used in This Manual	iv
Chapter 1 USB Interface	
1.1 Names and Functions of Parts	1-1
1.2 USB Interface Features and Specifications.....	1-2
1.3 Connecting via the USB Interface	1-3
1.4 Setting the AQ1300/AQ1301 (USB)	1-4
Chapter 2 Ethernet Interface/Telnet	
2.1 Names and Functions of Parts	2-1
2.2 Ethernet Interface Features and Specifications.....	2-2
2.3 Connecting the Ethernet Interface.....	2-3
2.4 Setting the AQ1300/AQ1301 (Network)	2-4
2.5 Telnet.....	2-6
Chapter 3 Before Programming	
3.1 Messages	3-1
3.2 Commands	3-3
3.3 Response	3-4
3.4 Data	3-5
Chapter 4 Commands	
4.1 List of Commands	4-1
4.2 MENU Group.....	4-4
4.3 CONFig Group	4-5
4.4 INBand Group	4-14
4.5 CONTrol Group	4-15
4.6 RESult:COUNter Group	4-16
4.7 COMMunicate Group	4-19
4.8 STATus Group	4-20
Chapter 5 Output Queue, and Error Queue	
5.1 Output and Error Queue.....	5-1
Appendix	
Appendix Error Messages.....	App-1
Index	

1

2

3

4

5

App

Index

1.1 Names and Functions of Parts

Front Panel

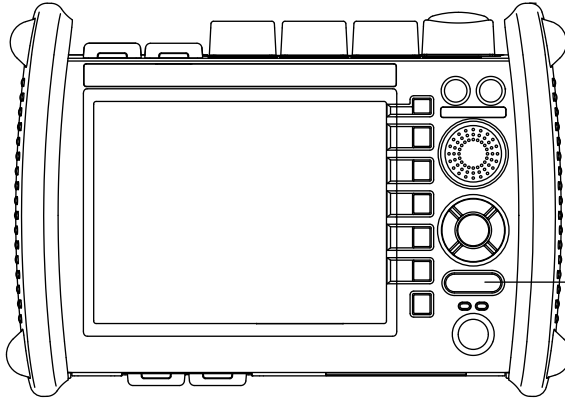

SETUP key
Press this key to select the USB interface.

Bottom

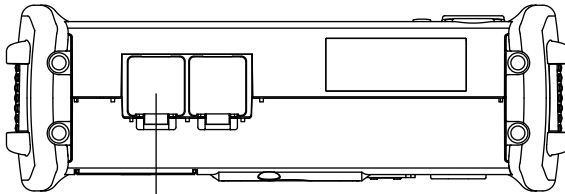

USB type B (mini B) connector
Connector used to connect the AQ1300/AQ1301 to the controller (such as a PC) using a USB cable.

1.2 USB Interface Features and Specifications

USB Interface Features

The AQ1300/AQ1301 auto tests (auto and auto (remote)) can be executed remotely from the PC.

USB Interface Specifications

Electrical and mechanical specifications:	Conforms to USB Rev.1.1
Connector:	Type B (mini B) connector (receptacle)
Number of ports:	1
Power supply:	Self-powered
Compatible PC systems:	PC running Windows 2000, Windows XP, or Windows Vista with a standard USB port (a separate device driver is needed to connect to a PC).

Switching between Remote and Local Modes

When Switching from Local to Remote Mode

Sending a command when the instrument is in the local mode causes the instrument to switch to the remote mode.

- All keys except the **Release** soft key are disabled.
- Settings entered in local mode are retained even when the AQ1300/AQ1301 switches to remote mode.

When Switching from Remote to Local Mode

Pressing the **Release** soft key in remote mode puts the instrument in local mode.

- Key operations are enabled.
- Settings entered in remote mode are retained even when the AQ1300/AQ1301 switches to local mode.

Note

The AQ1300/AQ1301 cannot be remotely controlled via the USB interface while the storage function is in operation. Remote control via the Ethernet interface is also not possible.

1.3 Connecting via the USB Interface

Connection Procedure

1. Open the bottom cover of the left side.
2. Connect a USB cable to the type B (mini B) connector.

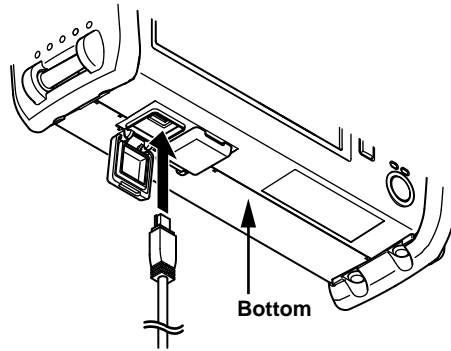

Precautions to Be Taken When Connecting the Cable

- Connect the USB cable by inserting the connector firmly into the USB connector.
- Do not connect or disconnect the USB cable after the power is turned ON until the AQ1300/AQ1301 is ready for operation (approximately 20 s).

1.4 Setting the AQ1300/AQ1301 (USB)

Procedure

Selecting the USB Interface Function

1. Press **SETUP** and then the **System Setup** soft key to display the following screen.

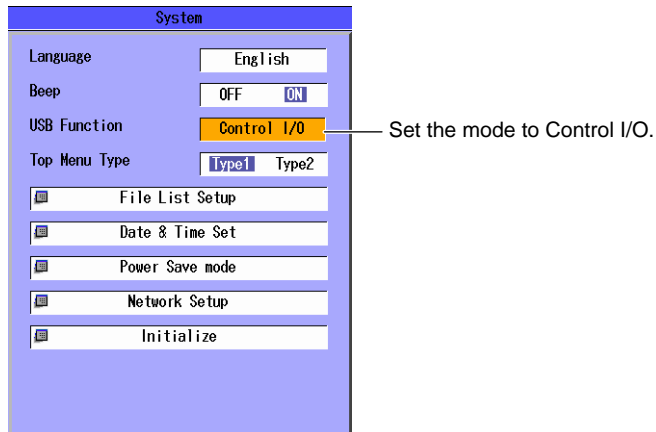

Releasing the Remote Control

1. Press the **Release** soft key that appears on the screen after communication starts.



Explanation

USB Interface

To control the AQ1300/AQ1301 remotely using communication commands through the USB port, install YOKOGAWA's TMC (Text and Measurement Class) driver into your PC. To obtain YOKOGAWA's USB TMC driver, contact your nearest YOKOGAWA dealer or access the following USB driver page at our Web site and download it.

<http://tmi.yokogawa.com/us/service-support/>

Note

- You cannot change the display while the AQ1300/AQ1301 is being remotely controlled.
- Only use the USB TMC driver (or software) provided by YOKOGAWA.

2.1 Names and Functions of Parts

Front Panel

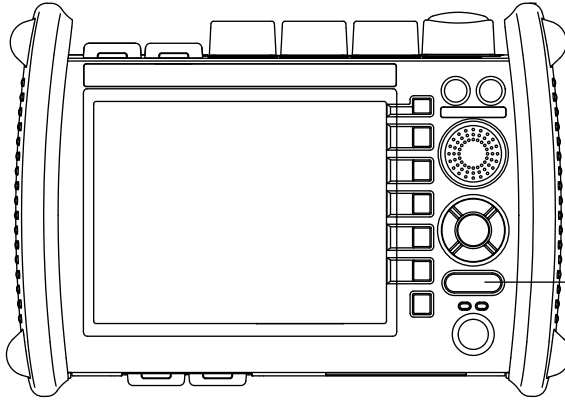

SETUP key
Press this key to select the ethernet interface.

Bottom

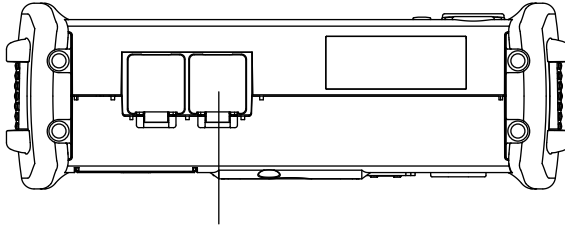

Ethernet Port
Connector used to connect the AQ1300/AQ1301 to the controller (such as a PC) using a ethernet cable.

2.2 Ethernet Interface Features and Specifications

Ethernet Interface Features

The AQ1300/AQ1301 auto tests (auto and auto (remote)) can be executed remotely from the PC.

Ethernet Interface Specifications

Electrical and mechanical specifications: Conforms to IEEE802.3

Transmission system: Ethernet (10BASE-T/100BASE-TX)

Data rate: 10 Mbps/100 Mbps

Number of communication ports: 1

Port number: 10001/tcp

Communication protocol: VXI-11

Connector type: RJ45 connector

Switching between Remote and Local Modes

When Switching from Local to Remote Mode

Sending a command when the instrument is in the local mode causes the instrument to switch to the remote mode.

- All keys except the **Release** soft key are disabled.
- Settings entered in local mode are retained even when the AQ1300/AQ1301 switches to remote mode.

When Switching from Remote to Local Mode

Pressing the **Release** soft key in remote mode puts the instrument in local mode.

- Key operations are enabled.
- Settings entered in remote mode are retained even when the AQ1300/AQ1301 to local mode.

Note

The AQ1300/AQ1301 cannot be remotely controlled via the USB interface while the storage function is in operation. Remote control via the Ethernet interface is also not possible.

FTP Feature

The AQ1300/AQ1301 has an FTP Feature. You can transfer the data stored in the AQ1300/AQ1301 internal memory to the PC using FTP commands from the PC.

2.3 Connecting the Ethernet Interface

Connection Procedure

1. Open the bottom cover of the right side.
2. Connect a UTP (Unshielded Twisted-Pair) cable or an STP (Shielded Twisted-Pair) cable that is connected to a hub, for example, to the 100BASE-TX port on the bottom of the AQ1300/AQ1301.

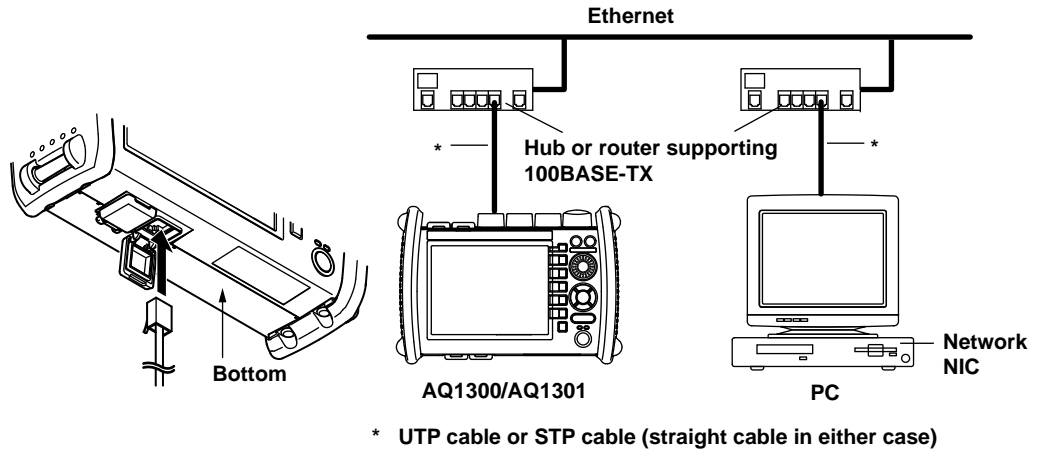

Precautions to Be Taken When Connecting the Cable

- Be sure to use a straight cable via a hub for the connection between the AQ1300/AQ1301 and the PC.
- Use a network cable that conforms to your network environment (such as the data rate).
- When using a UTP cable (straight cable), use a cable of category 5.

2.4 Setting the AQ1300/AQ1301 (Network)

The settings for remotely controlling the AQ1300/AQ1301 via the Ethernet interface are explained below.

Procedure

Selecting the Ethernet Interface Function

1. Press **SETUP** and then the **System Setup** soft key to display the following screen.

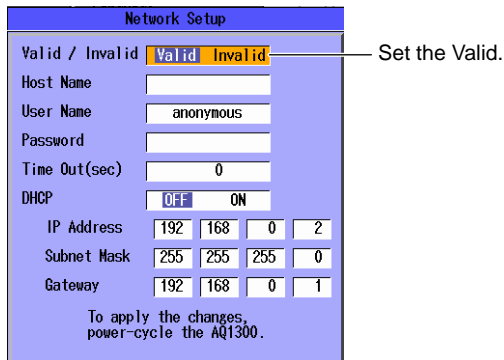

Network Setup				
Valid / Invalid	Valid	Invalid		
Host Name				
User Name	anonymous			
Password				
Time Out(sec)	0			
DHCP	<input type="checkbox"/> OFF <input type="checkbox"/> ON			
IP Address	192	168	0	2
Subnet Mask	255	255	255	0
Gateway	192	168	0	1
To apply the changes, power-cycle the AQ1300.				

Releasing the Remote Control

1. Press the **Release** soft key that appears on the screen after communication starts.



Remote
Release

Explanation**Setting the Ethernet Interface**

You must set the following parameters to use the Ethernet interface function.

- **Enabling or Disabling the Network Setup**

After you have set the user name, password, timeout value, and TCP/IP parameters, select Valid and then restart the AQ1300/AQ1301 to use the network connection.

- **User Name**

- **Password**

- **Setting the Timeout Value**

The connection to the network is automatically disconnected if there is no access to the AQ1300/AQ1301 for the specified time.

- **Setting the TCP/IP**

IP Address

Subnet Mask

Default Gateway

For details on how to configure the settings, see section 10.4, “Configuring Network Settings,” in the *AQ1300/AQ1301 ETHERNET Multi Field Tester User's Manual*, IM AQ1300-01EN.

Note

- You must restart the AQ1300/AQ1301 if you change the Ethernet settings. Before you restart the AQ1300/AQ1301, the settings from before you changed the settings are used.
- The AQ1300/AQ1301 cannot be remotely controlled via the ethernet interface while the USB storage function is in operation.

2.5 Telnet

The AQ1300/AQ1301 is equipped with a Telnet server feature.

You can use this feature to control the AQ1300/AQ1301 from a PC connected via the Ethernet interface.

Telnet Server Specifications

Controller Terminal

Terminal equipped with a Telnet (RFC854) feature

Connection

Port number: 23 (Telnet)

Simultaneous connections: 1

Simultaneous Telnet and front-panel control is not possible.

The AQ1300/AQ1301 cannot be controlled from the front panel when it is being accessed through Telnet (except for terminating the Telnet connection).

When the AQ1300/AQ1301 is being controlled from the front panel, Telnet login is not possible.

Security with login password

Connection timeout available

Echo Back

Fixed remote echo back

Changeable prompt (system device name assignment)

Allowed Characters (Codes)

Only the following characters (codes) can be used.

Alphanumeric characters and symbols [ASCII code: 2 (0x20) to 126 (0x7e)]

Backspace ('\b') [ASCII code: 8 (0x08)]

Line feed characters ('\r' and '\n') [ASCII code: 10 (0x0a) and 13 (0x0d)]

Kanji codes are not allowed.

3.1 Messages

Messages

Messages are used to exchange information between the controller and the instrument. Messages that are sent from the controller to the instrument are called program messages and messages that are sent back from the instrument to the controller are called response messages.

If a program message contains a message unit that requests a response (a query), the instrument returns a response message upon receiving the program message. A single response message is always returned in response to a single program message.

Program Messages Program Message Unit

A program message consists of zero or more program message units; each unit corresponds to one command. The instrument executes the received commands in order.

Each program message unit is separated by a semicolon (;).

Example `:PMETer:MODulation MOD_CW;UNIT DB<PMT>`

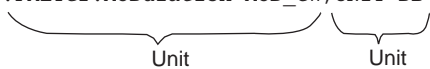

<PMT>

PMT is a program message terminator. The following three types are available.

- **NL (New Line)**
Same as LF (Line Feed). ASCII code "0AH" is used.
- **^END**
END message defined in IEEE488.1. (EOI signal) (The data byte sent with an END message will be the final item of the program message unit.)
- **NL^END**
NL with an END message added (NL is not included in the program message unit.)

Program Header

A program header is used to indicate the command type. For details, see section 3.2, "Commands."

Program Data

If certain conditions are required in executing a command, program data is added. A space (ASCII code "20H") separates the program data from the header. If there are multiple sets of program data, they are separated by commas (.). For details, see section 3.4, "Data."

Example `:PMETer:MODulation MOD_CW<PMT>`

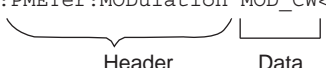

Response Messages Response Message Units

A response message consists of one or more response message units: each response message unit corresponds to one response. Response message units are delimited by a ";" (semicolon).

Example `:PMETer:MODulation MOD_CW;UNIT DB<PMT>`

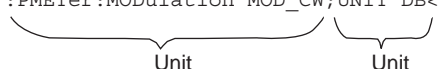

<RMT>

RMT stands for "response message terminator." The response message terminator is NL^EOM.

Response Header

A response header sometimes precedes the response data. A space separates the data from the header. For details, see section 3.3, "Response."

Response Data

Response data contains the content of the response. If there are multiple sets of response data, they are separated by commas (.). For details, see section 3.4, "Data."

Example `850E-9<RMT> :PMETer:MODulation MOD_CW<PMT>`

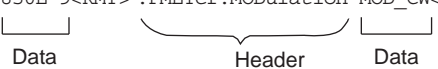

If there are multiple queries in a program message, responses are returned in the same order that the queries were received in. The AQ1300/AQ1301 returns a single response message unit to most queries, but there are queries that the AQ1300/AQ1301 returns multiple units to. The first response message unit always corresponds to the first query, but the nth response unit may not necessarily correspond to the nth query. If you want to make sure that every response is retrieved, divide the program messages into individual messages.

3.1 Messages

Note

- It is always possible to send a program message if the previous message which was sent did not contain any queries.
 - If the previous message contained a query, it is not possible to send another program message until a response message has been received. An error will occur if a program message is sent before a response message has been received in its entirety. A response message which has not been received will be discarded.
 - If an attempt is made by the controller to receive a response message, even if there is no response message, an error will occur. An error will also occur if the controller makes an attempt to receive a response message before transmission of a program message has been completed.
 - If a program message of more than one unit is sent and some of the units are incomplete, this instrument receives program message units which the instrument thinks complete and attempts to execute them. However, these attempts may not always be successful and a response may not always be returned, even if the program message contains queries.
-

3.2 Commands

Command

There are three types of commands (program headers) that a controller may send to the AQ1300/AQ1301. The commands differ in their program header formats.

Compound Header

Other commands that are specific to the AQ1300/AQ1301 are classified and arranged in a hierarchy according to their functions. Be sure to use a colon to specify a lower hierarchical level.

Compound header example :PMEter:LINK:STATe

When Concatenating Commands

Command Groups

A command group is a group of commands that have common compound headers arranged in a hierarchy. A command group may contain sub-groups.

Example

Commands relating to acquisition settings

```
:PMEter:DREF
:PMEter:LINK:STATe
:PMEter:MAXMin:STATe
:PMEter:MODulation
:PMEter:OFFSet
:PMEter:REFerence
:PMEter:WAVelength:DETail
```

When Concatenating Commands of the Same Group

The AQ1300/AQ1301 stores the hierarchical level of the command that is currently being executed and processes the next command on the assumption that it belongs to the same level. Therefore, the common header section can be omitted for commands that belong to the same group.

Example

```
:PMEter:MODulation MOD_CW;UNIT DB<PMT>
```

When Concatenating Commands of Different Groups

If the subsequent command does not belong to the same group, place a colon in front of the header (cannot be omitted).

Example

```
:PMEter:MODulation MOD_CW::MENU:
FUNction TOP<PMT>
```

When Separating Commands with <PMT>

If a terminator is used to separate two commands, each command is a separate message. Therefore, the common header must be typed in for each command even when commands of the same command group are being concatenated.

Example

```
:PMEter:MODulation MOD_CW<PMT>;PMEter
UNIT DB<PMT>
```

Upper-level Query

An upper-level query is a query that is made by appending a question mark to the highest level command of a group. The controller can receive all of the settings in a group collectively by executing an upper-level query. Some upper-level queries of a group, which may be comprised of more than three hierarchical levels, can cause the AQ1300/AQ1301 to transmit all the lower level settings.

Example

```
:NETWork:CONTRol?<PMT> -> :NETW:CONT:
PASS "ABC";TIM 30;USER "anonyumous"
```

Note

- The response to an upper-level query can be sent back to the AQ1300/AQ1301 as a program message. This enables the settings that were present when the upper-level query was made to be reproduced later on.
- Some upper-level queries do not return setup data that is not currently in use. Exercise caution because not all of a group's information is necessarily returned in a response.

Header Interpretation Rules

The AQ1300/AQ1301 interprets the header that it receives according to the rules below.

Example

"DRANge" can be written as "drange" or "Drange."

- The lower-case characters can be omitted.

Example

"DRANge" can be written as "DRANG" or "DRAN."

- The question mark at the end of a header indicates that it is a query. You cannot omit the question mark.

Example

The shortest abbreviation for "DRANge?" is "DRAN?."

- If the <x> (value) at the end of a mnemonic is omitted, it is interpreted as a 1.

Example

If you write "M" for "M<x>", "M1." is specified.

Note

A mnemonic is a character string made up of alphanumeric characters.)

3.3 Response

Form

When the controller sends a query with a question mark, the AQ1300/AQ1301 returns a response message to the query.

Response Consisting of a Header and Data

Responses that can be used as program messages without any changes are returned with command headers attached.

Example

```
:PMETer:MODulation?<PMT>  
-> :PMETer:MODulation MOD_270HZ<RMT>
```

If You Want the AQ1300/AQ1301 to Return Responses without Headers

You can configure the AQ1300/AQ1301 so that even responses that have both headers and data are returned without headers. Use the COMMunicate:HEADer command for this purpose.

Abbreviated Form

The AQ1300/AQ1301 normally returns response headers with the lower-case section removed. You can configure the AQ1300/AQ1301 so that full headers are returned. Use the COMMunicate:VERBose command for this purpose.

3.4 Data

Data contains conditions and values that are written after the header. A space separates the data from the header. Data is grouped as follows:

Data	Description
<Decimal>	A value expressed in decimal notation (Example: Western calendar year ->MISC:DATE:YEAR 2009)
<Distance><Time> <Wavelength><Loss>	A physical value (Example: Timeout value ->NETWork: CONTRol:TIMEout 30))
<Character data>	Predefined character string (mnemonic). Select from the available strings in braces. (Example: Select the function mode ->MENU:FUNCTION {TOP LSPM LOSStest PONPm MLOSstest IPTest})
<Boolean>	Indicates ON and OFF. Specify ON or OFF. (Example: Turn on the DHCP ->NETWork: DHCP ON))
<String data>	User-defined string (Example: Set the Network password ->NETWork:CONTRol:PASSword "ABC")

<Decimal>

<Decimal> indicates a value expressed as a decimal number, as shown in the table below. Decimal values are written in the NR form as specified in ANSI X3.42-1975.

Symbol	Description	Example		
<NR1>	Integer	125	-1	+1000
<NR2>	Fixed point number	125.0	-.90	+001.
<NR3>	Floating point number	125.0E+0	-9E-1	+1E4
<NRf>	Any of the forms <NR1> to <NR3> is allowed.			

- The AQ1300/AQ1301 can receive decimal values that are sent from the controller in any form, from <NR1> to <NR3>. This is expressed as <NRf>.
- The AQ1300/AQ1301 returns a response to the controller in one of the forms from <NR1> to <NR3> depending on the query. The same form is used regardless of the size of the value.
- For the <NR3> form, the plus sign after the "E" can be omitted. You cannot omit the minus sign.
- If a value outside the setting range is entered, the value is adjusted to the closest value within the range.
- If a value has more significant digits than are available, the value will be rounded.

<Distance>, <Time>, <Wavelength>, and <Loss>

<Distance>, <Time>, <Wavelength>, and <Loss> indicate decimal values that have physical significance. A <Multiplier> or <Unit> can be attached to the <NRf> form that was described earlier. The following types of expressions are possible.

Form	Example
<NRf><Multiplier><Unit>	0.85UM
<NRf><Unit>	500m
<NRf><Multiplier>	5M
<NRf>	5E -3

<Multiplier>

<Multipliers> that you can use are indicated in the following table.

Symbol	Word	Description
EX	Exa	10 ¹⁸
PE	Peta	10 ¹⁵
T	Tera	10 ¹²
G	Giga	10 ⁹
MA	Mega	10 ⁶
K	Kilo	10 ³
M	Milli	10 ⁻³
U	Micro	10 ⁻⁶
N	Nano	10 ⁻⁹
P	Pico	10 ⁻¹²
F	Femto	10 ⁻¹⁵
A	Atto	10 ⁻¹⁸

<Unit>

<Units> that you can use are indicated in the following table.

Symbol	Word	Description
M	Meter	Distance
S	Second	Time
dB	Decibel	Level
UM	Micro meter	Wavelength

- <Multiplier> and <Unit> are not case sensitive.
- "U" is used to indicate micro ("μ").
- "MA" is used for Mega to distinguish it from Milli.
- If both <Multiplier> and <Unit> are omitted, the default unit is used.

3.4 Data

<Character Data>

<Character data> is a predefined character string (mnemonics). It is mainly used to indicate that an option listed as a character string in braces must be selected and entered. The data interpretation rules are the same as those described in "Header Interpretation Rules" on page 3-4.

Form	Example
{SIMPLE DETAIL WIZARD MULTI}	DETAIL

- As with the header, the COMMunicate:VERBoSe command can be used to select whether to return the response in the full form or in the abbreviated form.
- The COMMunicate:HEADer setting does not affect <character data>.

<Boolean>

<Boolean> is data that indicates ON or OFF. The following types of expressions are possible.

Form	Example
{ON OFF <NRf>}	ON OFF 1 0

- When <Boolean> is expressed in the <NRf> form, "OFF" is selected if the rounded integer value is 0, and ON is selected for all other cases.
- A response message is always returned with a 1 if the value is ON and with a 0 if the value is OFF.

<String Data>

<String data> is not a predefined character string like <character data>. It can be any character string. The character string must be enclosed in single quotation marks (') or double quotation marks (").

Form	Example
<Character string data>	'ABC' "IEEE488.2-1987"

- If a character string contains a double quotation mark ("), the double quotation mark is expressed as two consecutive quotation marks (""). This rule also applies to single quotation marks.
- A response message is always enclosed in double quotation marks (").
- <String data> is any character string. Therefore, the AQ1300/AQ1301 assumes that the remaining program message units are part of the character string if no single (') or double quotation mark (") is encountered. As a result, no error is detected if a quotation mark is omitted.

<Block data>

<Block data> is any 8-bit data. It is only used in response messages on the AQ1300/AQ1301. The syntax is as follows:

Form	Example
#N <N-digit decimal number><data byte sequence>	#800000010ABCDEFGHIJ

- #N
Indicates that the data is <block data>."N" indicates the number of succeeding data bytes (digits) in ASCII code.
- <N-digit decimal number>
Indicates the number of bytes of data (example: 00000010 = 10 bytes).
- <Data byte sequence>
Expresses the actual data (example: ABCDEFGHIJ).
- Data is comprised of 8-bit values (0 to 255). This means that the ASCII code "0AH" which stands for "NL" can also be included in the data. Hence, care must be taken when programming the controller.

4.1 List of Commands

Command	Function	Page
MENU Group		
:MENU:FUNCTION	Selects a test menu.	4-4
:MENU:FILElist:LIST<x>?	Displays the content of the comment in the setup file list.	4-4
:MENU:FILElist:SElect	Selects the file to load from the setup file list.	4-4
:MENU:FILElist:DEFault	Selects the default settings.	4-4
:MENU:EXIT	Returns to the top screen.	4-4
:MENU:ERRor:CLEar	Clears the error dialog box.	4-4
CONFig Group		
:CONFig:AUTO:TEST:INTERface	Sets the measurement interface.	4-5
:CONFig:AUTO:TEST:LAYer	Sets the layer to test.	4-5
:CONFig:AUTO:TEST:UDP	Sets whether to add UDP to Tx frames.	4-5
:CONFig:AUTO:TEST:JUMBoframe	Sets whether to treat oversize frames like normal frames.	4-5
:CONFig:AUTO:LINK:NEGotiation	Select whether to use auto negotiation.	4-5
:CONFig:AUTO:LINK:SPEed	Sets the link speed when Test Interface is set to RJ-45.	4-5
:CONFig:AUTO:LINK:DUPLex	Sets the communication mode for when Speed is set to 100M or 10M.	4-6
:CONFig:AUTO:LINK:FLOWcontrol	Enables or disables flow control.	4-6
:CONFig:AUTO:LINK:MDI	Sets the measurement port to straight or crossover mode.	4-6
:CONFig:AUTO:ADDRESS:SRC:MAC:TYPE	Sets the source MAC address type.	4-6
:CONFig:AUTO:ADDRESS:SRC:MAC:ADDRESS	Sets the source MAC address.	4-6
:CONFig:AUTO:ADDRESS:SRC:VLAN:STACKs	Sets the number of VLAN stacks.	4-6
:CONFig:AUTO:ADDRESS:SRC:VLAN:TAG2:TPID	Sets the VLAN2 TPID.	4-6
:CONFig:AUTO:ADDRESS:SRC:VLAN:TAG2:CoS	Sets the VLAN2 CoS (Class of Service).	4-6
:CONFig:AUTO:ADDRESS:SRC:VLAN:TAG2:ID	Sets the VLAN2 VLAN-ID.	4-7
:CONFig:AUTO:ADDRESS:SRC:VLAN:TAG1:TPID	Sets the VLAN1 TPID.	4-7
:CONFig:AUTO:ADDRESS:SRC:VLAN:TAG1:CoS	Sets the VLAN1 CoS (Class of Service).	4-7
:CONFig:AUTO:ADDRESS:SRC:VLAN:TAG1:ID	Sets the VLAN1 VLAN-ID.	4-7
:CONFig:AUTO:ADDRESS:SRC:IPV4:TYPE	Selects whether to specify the source IPv4 address manually or to acquire and set it automatically through DHCP.	4-7
:CONFig:AUTO:ADDRESS:SRC:IPV4:ADDRESS	Sets the source IPv4 address.	4-7
:CONFig:AUTO:ADDRESS:SRC:IPV4:SUBNetmask	Sets the length of the net mask.	4-7
:CONFig:AUTO:ADDRESS:SRC:IPV4:GATeway	Sets the gateway address.	4-7
:CONFig:AUTO:ADDRESS:SRC:IPV6:TYPE	Selects whether to specify the source IPv6 address manually or to specify it through stateless autoconfiguration using the RA from an IPv6 router.	4-8
:CONFig:AUTO:ADDRESS:SRC:IPV6:ADDRESS	Sets the source IPv6 address.	4-8
:CONFig:AUTO:ADDRESS:SRC:IPV6:ROUTer:MANual	Sets whether to manually set the router address and prefix length.	4-8
:CONFig:AUTO:ADDRESS:SRC:IPV6:ROUTer:PREFixlength	Sets the prefix length when setting the router address manually. When the router address is obtained automatically, the obtained prefix length is displayed.	4-8
:CONFig:AUTO:ADDRESS:SRC:IPV6:ROUTer:ADDRESS	Sets the router address when setting the router address manually. When the router address is obtained automatically, the obtained address is displayed.	4-8
:CONFig:AUTO:ADDRESS:DST:MAC:TYPE	Sets the destination MAC address type.	4-8

4.1 List of Commands

Command	Function	Page
:CONFig:AUTO:ADDRess:DST:MAC:ADDRess	Set the destination MAC address.	4-9
:CONFig:AUTO:ADDRess:DST:IPV4:ADDRess	Sets the destination IPv4 address.	4-9
:CONFig:AUTO:ADDRess:DST:IPV6:ADDRess	Sets the source IPv6 address.	4-9
:CONFig:AUTO:ITEM:SElect	Selects the test item that you want to execute.	4-9
:CONFig:AUTO:ITEM:LIST?	Displays a list of registered test items.	4-9
:CONFig:AUTO:MASTerslave	Selects which device to configure and display the results of, either master or slave, for auto remote mode.	4-9
:CONFig:AUTO:TRAFfic:TXRate	Sets the transmission rate of the traffic test.	4-9
:CONFig:AUTO:TRAFfic:TXMode	Sets the transmission mode.	4-9
:CONFig:AUTO:TRAFfic:TXTime	Sets the transmission time when the transmission mode of the traffic test is set to time.	4-10
:CONFig:AUTO:TRAFfic:TXFRames	Sets the number of frames when the transmission mode of the traffic test is set to frames.	4-10
:CONFig:AUTO:TRAFfic:FRAMelength	Sets the Transmission frame length of the traffic test.	4-10
:CONFig:AUTO:TRAFfic:ACTUallength?	Displays the actual frame length of the specified frame of the traffic test.	4-10
:CONFig:AUTO:TRAFfic:FILLpattern	Sets the fill pattern to insert in the payload area of the traffic test.	4-10
:CONFig:AUTO:LOOPback:TARGet	Sets the loopback target frame of the loopback test.	4-10
:CONFig:AUTO:QOS:TXMode	Sets the QoS test transmission mode.	4-10
:CONFig:AUTO:QOS:TXTime	Sets the transmission time when the transmission mode of the QoS test is set to time.	4-10
:CONFig:AUTO:QOS:TXFRames	Sets the number of frames when the transmission mode of the QoS test is set to frames.	4-11
:CONFig:AUTO:QOS:FIELD	Sets the QoS target field of the QoS test.	4-11
:CONFig:AUTO:QOS:CH<x>:ENABle	Enables or disables CH<x> of the QoS test.	4-11
:CONFig:AUTO:QOS:CH<x>:TXRate	Sets the CH<NRf> test transmission rate of the QoS test.	4-11
:CONFig:AUTO:QOS:CH<x>:VALue	Sets the CH QoS value of the QoS test.	4-11
:CONFig:AUTO:QOS:CH<x>:FRAMelength	Sets the transmission frame length of CH<x> of the QoS test.	4-11
:CONFig:AUTO:QOS:CH<x>:ACTUallength?	Displays the actual transmission frame length of the specified frame of CH of the QoS test.	4-11
:CONFig:AUTO:QOS:FILLpattern	Sets the fill pattern to insert in the payload area of the QoS test.	4-11
:CONFig:AUTO:PING:INTerval	Sets the PING test transmission interval.	4-12
:CONFig:AUTO:PING:TXMode	Sets the PING test transmission mode.	4-12
:CONFig:AUTO:PING:TXTime	Sets the transmission time in unit of minutes when the transmission mode of the PING test is set to time.	4-12
:CONFig:AUTO:PING:TXFRames	Sets the number of frames when the transmission mode of the PING test is set to frames.	4-12
:CONFig:AUTO:PING:FRAMelength	Sets the Transmission frame length of the PING test.	4-12
:CONFig:AUTO:PING:ACTUallength?	Displays the actual frame length of the specified frame of the PING test.	4-12
:CONFig:AUTO:BERT:TXRate	Sets the BERT test transmission rate.	4-12
:CONFig:AUTO:BERT:TXMode	Sets the BERT test transmission mode.	4-12
:CONFig:AUTO:BERT:TXTime	Sets the transmission time when the transmission mode of the BERT test is set to time.	4-13
:CONFig:AUTO:BERT:TXFRames	Sets the number of frames when the transmission mode of the BERT test is set to frames.	4-13
:CONFig:AUTO:BERT:FRAMelength	Sets the Transmission frame length of the BERT test.	4-13
:CONFig:AUTO:BERT:ACTUallength?	Displays the actual frame length of the specified frame of the BERT test.	4-13
INBand Group		
:INBand:CONNect	Connects or disconnects the measurement on the slave side during auto remote mode.	4-14

Command	Function	Page
CONTROL Group		
:CONTROL:MEASURE	Starts or stops measurement.	4-15
:CONTROL:TRANSMIT	Starts or stops the transmission of test frames.	4-15
:CONTROL:NEXT	Executes the next test when the AQ1300/AQ1301 is ready to execute the next test.	4-15
:CONTROL:STATUS?	Displays the current measurement execution status.	4-15
RESULT:COUNTER Group		
:RESULT:COUNTER:COMMON?	Displays all counter values in the common group. You can also display a specific counter.	4-16
:RESULT:COUNTER:LINK?	Displays all counter values in the link group. You can also display a specific counter.	4-16
:RESULT:COUNTER:TX?	Displays all counter values in the transmission group. You can also display a specific counter.	4-16
:RESULT:COUNTER:RX?	Displays all counter values in the reception group. You can also display a specific counter.	4-17
:RESULT:COUNTER:RXERROR?	Displays all counter values in the reception error group. You can also display a specific counter.	4-17
:RESULT:COUNTER:LATENCY?	Displays all counter values in the delay group. You can also display a specific counter.	4-17
:RESULT:COUNTER:SEQUENCE?	Displays all counter values in the sequence group. You can also display a specific counter.	4-17
:RESULT:COUNTER:PAYLOAD?	Displays all counter values in the payload group. You can also display a specific counter.	4-17
:RESULT:COUNTER:CH<x>TX?	Displays all counter values in the CH<x>Tx group. You can also display a specific counter.	4-18
	Counter values without measurement results appear as "NaN."	4-18
:RESULT:COUNTER:CH<x>RX?	Displays all counter values in the CH<x>Rx group. You can also display a specific counter.	4-18
	Counter values without measurement results appear as "NaN."	4-18
:RESULT:COUNTER:BERT?	Displays all counter values in the BERT group. You can also display a specific counter.	4-18
:RESULT:COUNTER:PING?	Displays all counter values in the PING group. You can also display a specific counter.	4-18
COMMUNICATE Group		
:COMMUNICATE:HEADER	Sets or queries whether a header is added to the response to a query (example with header: ":INBand:CONNECT CONNECT"; example without header: "CONNECT").	4-19
:COMMUNICATE:VERBOSE	Sets or queries whether the response to a query is returned fully spelled out (e.g., :INBand:CONNECT CONNECT) or in its abbreviated form (e.g., INB:CONN CONNECT).	4-19
:COMMUNICATE:TELNET:ERROR	Sets the error display timing for Telnet connection.	4-19
STATUS Group		
:STATUS:ERROR?	Queries the error code and message of the last error that has occurred (top of the error queue).	4-20
:STATUS:QMESsage	Sets or queries whether message information will be attached to the response to the STATUS:ERROR? query.	4-20

4.2 MENU Group

Select a test menu. The commands in this group deal with the selection of setup files.

:MENU:FUNCTION

Function Selects a test menu.

Syntax :MENU:FUNCTION{AUTO|REMOTE}

Example :MENU:FUNCTION AUTO

:MENU:FUNCTION?

->:MENU:FUNCTION AUTO

Description AUTO: Auto mode is selected.

REMOTE: Auto remote mode is selected.

NOTE: Mode is not selected (query only).

:MENU:FILElist:LIST<x>?

Function Displays the content of the comment in the setup file list.

Syntax :MENU:FILElist:LIST<NRf>?

Example :MENU:FILELIST:LIST1?

->:MENU:FILELIST:LIST1

"SAMPLE_TEST01"

Description <NRf>: Specify the number in the file list (1 to 48).

:MENU:FILElist:SElect

Function Selects the file to load from the setup file list.

Syntax :MENU:FILElist:SElect{<NRf>}

<NRf>: 1 to 48

Example :MENU:FILELIST:SELECT 1

:MENU:FILELIST:SELECT?

->:MENU:FILELIST:SELECT 1

Description Enter the setup file number.

:MENU:FILElist:DEfault

Function Selects the default settings.

Syntax :MENU:FILElist:DEfault

Example :MENU:FILELIST:DEFAULT

Description Overwrites the current settings with the default settings.

:MENU:EXIT

Function Returns to the top screen.

Syntax :MENU:EXIT

Example :MENU:EXIT

Description Ends the auto or auto remote mode and returns to the top screen.

:MENU:ERRor:CLEar

Function Clears the error dialog box.

Syntax :MENU:ERRor:CLEar

Example :MENU:ERRor:CLEar

Description Clears the error dialog box shown on the AQ1300/AQ1301 screen.

4.3 CONFig Group

The commands in this group deal with measurement parameter settings. Various settings can be changed and queries.

:CONFig:AUTO:TEST:INTERface

Function Sets the measurement interface.

Syntax `:CONFig:AUTO:TEST:INTERface{XFP
|SFP|SFPFE|RJ45|}`

Example `:CONFIG:AUTO:TEST:INTERFACE XFP
:CONFIG:AUTO:TEST:INTERFACE?
->:CONFIG:AUTO:TEST:INTERFACE XFP`

Description XFP: Select this option to use the 10GBASE-R measurement port.
SFP: Select this option to use the 1000BASE-X measurement port.
SFPFE: Select this option to use the 100BASE-X measurement port.
RJ-45: Select this option to use the 10BASE-T/100BASE-TX/1000BASE-T measurement port.

:CONFig:AUTO:TEST:LAYer

Function Sets the layer to test.

Syntax `:CONFig:AUTO:TEST:
LAYer{L2|IPV4|IPV6}`

Example `:CONFIG:AUTO:TEST:LAYER L2
:CONFIG:AUTO:TEST:LAYER?
->:CONFIG:AUTO:TEST:LAYER L2`

Description L2: Select this option to test layer 2.
IPV4: Select this option to test layer 3 according to the IPv4 protocol.
IPV6: Select this option to test layer 3 according to the IPv6 protocol.

:CONFig:AUTO:TEST:UDP

Function Sets whether to add UDP to Tx frames.

Syntax `:CONFig:AUTO:TEST:UDP{ON|OFF}`

Example `:CONFIG:AUTO:TEST:UDP ON
:CONFIG:AUTO:TEST:UDP?
->:CONFIG:AUTO:TEST:UDP ON`

Description You can use this command when the test layer is L3-IPv4 or L3-IPv6.
ON: UDP is added to Tx frames.
OFF: UDP is not added to Tx frames.

:CONFig:AUTO:TEST:JUMBoframe

Function Sets whether to treat oversize frames like normal frames.

Syntax `:CONFig:AUTO:TEST:JUMBoframe{ON
|OFF}`

Example `:CONFIG:AUTO:TEST:JUMBOFRAME ON
:CONFIG:AUTO:TEST:JUMBOFRAME?
->:CONFIG:AUTO:TEST:JUMBOFRAME ON`

Description ON: Frames whose length is between 64 and 9999 bytes are considered to be normal frames.
OFF: Frames that are longer than 1518 + the value set for "VLAN stacks" in the source settings × 4 bytes are considered oversized.

:CONFig:AUTO:LINK:NEGotiation

Function Select whether to use auto negotiation.

Syntax `:CONFig:AUTO:LINK:
NEGotiation{AUTO|MANUAL}`

Example `:CONFIG:AUTO:LINK:NEGOTIATION AUTO
:CONFIG:AUTO:LINK:NEGOTIATION?
->:CONFIG:AUTO:LINK:NEGOTIATION AUTO`

Description This command is valid when Test Interface is set to RJ-45 or SFP(GbE).
AUTO: The link between the AQ1300/AQ1301 and the device that it is connected to is configured automatically through auto negotiation.
MANUAL: The link must be configured manually.

:CONFig:AUTO:LINK:SPEed

Function Sets the link speed when Test Interface is set to RJ-45.

Syntax `:CONFig:AUTO:LINK:SPEed{S10G|S1G|S10
0M|S10M|AUTO}`

Example `:CONFIG:AUTO:LINK:SPEED S1G
:CONFIG:AUTO:LINK:SPEED?
->:CONFIG:AUTO:LINK:SPEED S1G`

Description S10G: 10 Gbit/s (10GBASE-R) is in use. [Only for querying]
S1G: 1 Gbit/s 1000BASE-T is in use. Or, 1 Gbit/s (1000BASE-X) is in use.
S100M: 100 Mbit/s (100BASE-TX) is in use.
S10M: 10 Mbit/s (10BASE-T) is in use.
AUTO: The link speed is set automatically. This command is valid when Negotiation is set to Auto.

4.3 CONFIg Group

:CONFIg:AUTO:LINK:DUPLex

Function Sets the communication mode for when Speed is set to 100M or 10M.

Syntax :CONFIg:AUTO:LINK:DUPLex{FULL|HALF|AUTO}

Example :CONFIg:AUTO:LINK:DUPLEx FULL
:CONFIg:AUTO:LINK:DUPLEx?
->:CONFIg:AUTO:LINK:DUPLEx FULL

Description This command is valid when Test Interface is set to RJ-45.

FULL: Full duplex communication

HALF: Half duplex communication

AUTO: The AQ1300/AQ1301 chooses full or half duplex automatically. This command is valid when Negotiation is set to Auto.

:CONFIg:AUTO:LINK:FLOWcontrol

Function Enables or disables flow control.

Syntax :CONFIg:AUTO:LINK:FLOWcontrol{ON|OFF}

Example :CONFIg:AUTO:LINK:FLOWCONTROL ON
:CONFIg:AUTO:LINK:FLOWCONTROL?
->:CONFIg:AUTO:LINK:FLOWCONTROL ON

Description ON: Flow control is enabled.

OFF: Flow control is disabled.

:CONFIg:AUTO:LINK:MDI

Function Sets the measurement port to straight or crossover mode.

Syntax :CONFIg:AUTO:LINK:MDI{MDI|MDI_X|AUTO}

Example :CONFIg:AUTO:LINK:MDI MDI
:CONFIg:AUTO:LINK:MDI?
->:CONFIg:AUTO:LINK:MDI MDI

Description This command is valid when Test Interface is set to RJ-45.

MDI: Straight

MDI_X: Cross

AUTO: The AQ1300/AQ1301 switches between straight and crossover mode automatically (this command is valid when Negotiation is set to Auto).

:CONFIg:AUTO:ADDRESS:SRC:MAC:TYPE

Function Sets the source MAC address type.

Syntax :CONFIg:AUTO:ADDRESS:SRC:MAC:TYPE{GLOBAL|MANUAL}

Example :CONFIg:AUTO:ADDRESS:SRC:MAC:TYPE GLOBAL
:CONFIg:AUTO:ADDRESS:SRC:MAC:TYPE?
->:CONFIg:AUTO:ADDRESS:SRC:MAC:TYPEGLOBAL

Description GLOBAL: The global MAC address assigned to the measuring instrument is used.

MANUAL: The MAC address that you enter is used.

:CONFIg:AUTO:ADDRESS:SRC:MAC:ADDRESS

Function Sets the source MAC address.

Syntax :CONFIg:AUTO:ADDRESS:SRC:MAC:ADDRESS{ "<MAC Address>" }

Example :CONFIg:AUTO:ADDRESS:SRC:MAC:ADDRESS "00:00:00:00:00:01"
:CONFIg:AUTO:ADDRESS:SRC:MAC:ADDRESS?
->:CONFIg:AUTO:ADDRESS:SRC:MAC:ADDRESS"00:00:00:00:00:01"

Description Format: "xx:xx:xx:xx:xx:xx"

:CONFIg:AUTO:ADDRESS:SRC:VLAN:STACKs

Function Sets the number of VLAN stacks.

Syntax :CONFIg:AUTO:ADDRESS:SRC:VLAN:STACKs{<Nrf>}
<Nrf>: 0 to 2

Example :CONFIg:AUTO:ADDRESS:SRC:VLAN:STACKS 0
:CONFIg:AUTO:ADDRESS:SRC:VLAN:STACKS?
->:CONFIg:AUTO:ADDRESS:SRC:VLAN:STACKS 0

Description 0: No VLAN stacks

1: One VLAN stack

2: Two VLAN stacks

:CONFIg:AUTO:ADDRESS:SRC:VLAN:TAG2:TPID

Function Sets the VLAN2 TPID.

Syntax :CONFIg:AUTO:ADDRESS:SRC:VLAN:TAG2:TPID{#H<TPID>}
<TPID>: 0 to FFFF

Example :CONFIg:AUTO:ADDRESS:SRC:VLAN:TAG2:TPID #H88a8
:CONFIg:AUTO:ADDRESS:SRC:VLAN:TAG2:TPID?
->:CONFIg:AUTO:ADDRESS:SRC:VLAN:TAG2:TPID #H88A8

Description Selectable range: 0000 to FFFF (HEX)

:CONFIg:AUTO:ADDRESS:SRC:VLAN:TAG2:COS

Function Sets the VLAN2 CoS (Class of Service).

Syntax :CONFIg:AUTO:ADDRESS:SRC:VLAN:TAG2:COS{<Nrf>}
<Nrf>: 0 to 7

Example :CONFIg:AUTO:ADDRESS:SRC:VLAN:TAG2:COS 0
:CONFIg:AUTO:ADDRESS:SRC:VLAN:TAG2:COS?
->:CONFIg:AUTO:ADDRESS:SRC:VLAN:TAG2:COS 0

Description Selectable range: 0 to 7

:CONFIG:AUTO:ADDRESS:SRC:VLAN:TAG2:ID

Function Sets the VLAN2 VLAN-ID.

Syntax :CONFIG:AUTO:ADDRESS:SRC:VLAN:TAG2:
ID{<Nrf>}
<Nrf>: 0 to 4095

Example :CONFIG:AUTO:ADDRESS:SRC:VLAN:TAG2:
ID 0
:CONFIG:AUTO:ADDRESS:SRC:VLAN:TAG2:
ID?
->:CONFIG:AUTO:ADDRESS:SRC:VLAN:
TAG2:ID 0

Description Selectable range: 0 to 4095

:CONFIG:AUTO:ADDRESS:SRC:VLAN:TAG1:TPID

Function Sets the VLAN1 TPID.

Syntax :CONFIG:AUTO:ADDRESS:SRC:VLAN:TAG1:
TPID{#H<TPID>}
<TPID>: 0 to FFFF

Example :CONFIG:AUTO:ADDRESS:SRC:VLAN:TAG1:
TPID #H8100
:CONFIG:AUTO:ADDRESS:SRC:VLAN:TAG1:
TPID?
->:CONFIG:AUTO:ADDRESS:SRC:VLAN:
TAG1:TPID #H8100

Description Selectable range: 0000 to FFFF (HEX)

:CONFIG:AUTO:ADDRESS:SRC:VLAN:TAG1:CoS

Function Sets the VLAN1 CoS (Class of Service).

Syntax :CONFIG:AUTO:ADDRESS:SRC:VLAN:TAG1:
COS{<Nrf>}
<Nrf>: 0 to 7

Example :CONFIG:AUTO:ADDRESS:SRC:VLAN:TAG1:
COS 0
:CONFIG:AUTO:ADDRESS:SRC:VLAN:TAG1:
COS?
->:CONFIG:AUTO:ADDRESS:SRC:VLAN:
TAG1:CoS 0

Description Selectable range: 0 to 7

:CONFIG:AUTO:ADDRESS:SRC:VLAN:TAG1:ID

Function Sets the VLAN1 VLAN-ID.

Syntax :CONFIG:AUTO:ADDRESS:SRC:VLAN:TAG1:
ID{<Nrf>}
<Nrf>: 0 to 4095

Example :CONFIG:AUTO:ADDRESS:SRC:VLAN:TAG1:
ID 100
:CONFIG:AUTO:ADDRESS:SRC:VLAN:TAG1:
ID?
->:CONFIG:AUTO:ADDRESS:SRC:VLAN:
TAG1:ID 100

Description Selectable range: 0 to 4095

:CONFIG:AUTO:ADDRESS:SRC:IPV4:TYPE

Function Selects whether to specify the source IPv4 address manually or to acquire and set it automatically through DHCP.

Syntax :CONFIG:AUTO:ADDRESS:SRC:IPV4:
TYPE{MANUAL|DHCP}

Example :CONFIG:AUTO:ADDRESS:SRC:IPV4:TYPE
MANUAL
:CONFIG:AUTO:ADDRESS:SRC:IPV4:TYPE?
->:CONFIG:AUTO:ADDRESS:SRC:IPV4:TYPE
MANUAL

Description This command is valid when Test Layer is set to L3-IPv4 Test.

MANUAL: You must set the source IPv4 address manually.

DHCP: When you retrieve the IP address, the AQ1300/AQ1301 acquires and sets the source IPv4 address using DHCP.

:CONFIG:AUTO:ADDRESS:SRC:IPV4:ADDRESS

Function Sets the source IPv4 address.

Syntax :CONFIG:AUTO:ADDRESS:SRC:IPV4:
ADDRESS{ "<IP Address>" }

Example :CONFIG:AUTO:ADDRESS:SRC:IPV4:
ADDRESS "192.168.0.1"
:CONFIG:AUTO:ADDRESS:SRC:IPV4:
ADDRESS?
->:CONFIG:AUTO:ADDRESS:SRC:IPV4:
ADDRESS"192.168.0.1"

Description Format: "192.168.0.1"

:CONFIG:AUTO:ADDRESS:SRC:IPV4:SUBNetmask

Function Sets the length of the net mask.

Syntax :CONFIG:AUTO:ADDRESS:SRC:IPV4:
SUBNetmask{<Nrf>}
<Nrf>: 1 to 31

Example :CONFIG:AUTO:ADDRESS:SRC:IPV4:
SUBNETMASK 24
:CONFIG:AUTO:ADDRESS:SRC:IPV4:
SUBNETMASK?
->:CONFIG:AUTO:ADDRESS:SRC:IPV4:
SUBNETMASK 24

Description Selectable range: 1 to 31

:CONFIG:AUTO:ADDRESS:SRC:IPV4:GATeway

Function Sets the gateway address.

Syntax :CONFIG:AUTO:ADDRESS:SRC:IPV4:
GATeway{ "<IP Address>" }

Example :CONFIG:AUTO:ADDRESS:SRC:IPV4:
GATEWAY "192.168.0.254"
:CONFIG:AUTO:ADDRESS:SRC:IPV4:
GATEWAY?
->:CONFIG:AUTO:ADDRESS:SRC:IPV4:
GATEWAY"192.168.0.254"

Description Format: "192.168.0.254"

4.3 CONFIG Group

:CONFIG:AUTO:ADDRESS:SRC:IPV6:TYPE

Function Selects whether to specify the source IPv6 address manually or to specify it through stateless autoconfiguration using the RA from an IPv6 router.

Syntax :CONFIG:AUTO:ADDRESS:SRC:IPV6:TYPE {MANUAL|AUTO}

Example :CONFIG:AUTO:ADDRESS:SRC:IPV6:TYPE
MANUAL
:CONFIG:AUTO:ADDRESS:SRC:IPV6:TYPE?
->:CONFIG:AUTO:ADDRESS:SRC:IPV6:TYPE
MANUAL

Description This command is valid when Test Layer is set to L3-IPv6 Test.
MANUAL: You must set the source IPv6 address manually.
AUTO: When you retrieve the IP address, the AQ1300/AQ1301 automatically configures the source IPv6 address.

:CONFIG:AUTO:ADDRESS:SRC:IPV6:ADDRESS

Function Sets the source IPv6 address.

Syntax :CONFIG:AUTO:ADDRESS:SRC:IPV6:ADDRESS { "<IPv6 Address>" }

Example :CONFIG:AUTO:ADDRESS:SRC:IPV6:ADDRESS "FF80:0000:0000:0000:0000:0000:00:0001"
:CONFIG:AUTO:ADDRESS:SRC:IPV6:ADDRESS?
->:CONFIG:AUTO:ADDRESS:SRC:IPV6:ADDRESS"FF80:0000:0000:0000:0000:0000:0000:0001"

Description Format: "FF80:0000:0000:0000:0000:0000:0000:0001"

:CONFIG:AUTO:ADDRESS:SRC:IPV6:ROUTER:MANUAL

Function Sets whether to manually set the router address and prefix length.

Syntax :CONFIG:AUTO:ADDRESS:SRC:IPV6:ROUTER:MANUAL {ON|OFF}

Example :CONFIG:AUTO:ADDRESS:SRC:IPV6:ROUTER:MANUAL ON
:CONFIG:AUTO:ADDRESS:SRC:IPV6:ROUTER:MANUAL?
->:CONFIG:AUTO:ADDRESS:SRC:IPV6:ROUTER:MANUAL ON

Description ON: The router address and prefix length are set manually.
OFF: The router address and prefix length are obtained automatically at the start of a test.

:CONFIG:AUTO:ADDRESS:SRC:IPV6:ROUTER:PREFIXLENGTH

Function Sets the prefix length when setting the router address manually. When the router address is obtained automatically, the obtained prefix length is displayed.

Syntax :CONFIG:AUTO:ADDRESS:SRC:IPV6:ROUTER:PREFIXLENGTH {<Nrf>}
<Nrf>: 1 to 127

Example :CONFIG:AUTO:ADDRESS:SRC:IPV6:ROUTER:PREFIXLENGTH 64
:CONFIG:AUTO:ADDRESS:SRC:IPV6:ROUTER:PREFIXLENGTH?
->:CONFIG:AUTO:ADDRESS:SRC:IPV6:ROUTER:PREFIXLENGTH 64

Description Selectable range: 1 to 127

:CONFIG:AUTO:ADDRESS:SRC:IPV6:ROUTER:ADDRESS

Function Sets the router address when setting the router address manually. When the router address is obtained automatically, the obtained address is displayed.

Syntax :CONFIG:AUTO:ADDRESS:SRC:IPV6:ROUTER:ADDRESS { "<IPv6 Address>" }

Example :CONFIG:AUTO:ADDRESS:SRC:IPV6:ROUTER:ADDRESS "FF80:0000:0000:0000:0000:0000:0000:0001"
:CONFIG:AUTO:ADDRESS:SRC:IPV6:ROUTER:ADDRESS?
->:CONFIG:AUTO:ADDRESS:SRC:IPV6:ROUTER:ADDRESS"FF80:0000:0000:0000:0000:0000:0000:0001"

Description Format: "FF80:0000:0000:0000:0000:0000:0000:0001"

:CONFIG:AUTO:ADDRESS:DST:MAC:TYPE

Function Sets the destination MAC address type.

Syntax :CONFIG:AUTO:ADDRESS:DST:MAC:TYPE {ARP|MANUAL}

Example :CONFIG:AUTO:ADDRESS:DST:MAC:TYPE ARP
:CONFIG:AUTO:ADDRESS:DST:MAC:TYPE?
->:CONFIG:AUTO:ADDRESS:DST:MAC:TYPE ARP

Description ARP: The destination MAC address is obtained automatically.
MANUAL: The destination MAC address is specified manually.

:CONFIG:AUTO:ADDRESS:DST:MAC:ADDRESS

Function Set the destination MAC address.

Syntax :CONFIG:AUTO:ADDRESS:DST:MAC:
ADDRESS{ "<MAC Address>" }

Example :CONFIG:AUTO:ADDRESS:DST:MAC:ADDRESS
"00:00:00:00:00:01"
:CONFIG:AUTO:ADDRESS:DST:MAC:
ADDRESS?
->:CONFIG:AUTO:ADDRESS:DST:MAC:
ADDRESS"00:00:00:00:00:01"

Description Format: "xx:xx:xx:xx:xx:xx"

:CONFIG:AUTO:ADDRESS:DST:IPV4:ADDRESS

Function Sets the destination IPv4 address.

Syntax :CONFIG:AUTO:ADDRESS:DST:IPV4:
ADDRESS{ "<IPAddress>" }

Example :CONFIG:AUTO:ADDRESS:DST:IPV4:
ADDRESS"192.168.0.1"
:CONFIG:AUTO:ADDRESS:DST:IPV4:
ADDRESS?
->:CONFIG:AUTO:ADDRESS:DST:IPV4:
ADDRESS "192.168.0.1"

Description Format: "192.168.0.1"

:CONFIG:AUTO:ADDRESS:DST:IPV6:ADDRESS

Function Sets the source IPv6 address.

Syntax :CONFIG:AUTO:ADDRESS:DST:IPV6:
ADDRESS{ "<IPv6 Addr>" }

Example :CONFIG:AUTO:ADDRESS:DST:IPV6:
ADDRESS"FF80:0000:0000:0000:0000:0000:0000:0001"
:CONFIG:AUTO:ADDRESS:DST:IPV6:
ADDRESS?
->:CONFIG:AUTO:ADDRESS:DST:IPV6:
ADDRESS"FF80:0000:0000:0000:0000:0000:0000:0001"

Description Format: "FF80:0000:0000:0000:0000:0000:0000:0001"

:CONFIG:AUTO:ITEM:SELECT

Function Selects the test item that you want to execute.

Syntax :CONFIG:AUTO:ITEM:
SELECT{ ITEM(n) } (n):1-8

Example :CONFIG:AUTO:ITEM:SELECT ITEM1
:CONFIG:AUTO:ITEM:SELECT?
->:CONFIG:AUTO:ITEM:SELECT ITEM1

Description ITEM1: Selects test item 1.
ITEM2 Selects test item 2.
ITEM3 Selects test item 3.
ITEM4 Selects test item 4.
ITEM5 Selects test item 5.
ITEM6 Selects test item 6.
ITEM7 Selects test item 7.
ITEM8 Selects test item 8.

:CONFIG:AUTO:ITEM:LIST?

Function Displays a list of registered test items.

Syntax :CONFIG:AUTO:ITEM:LIST?

Example :CONFIG:AUTO:ITEM:LIST?
->:CONFIG:AUTO:ITEM:LIST 4,PING,TRAFFIC,QOS,TRAFFIC

Description Response data: <number of Items>[,<Item1 Type>][,<Item2 Type>] ...
<number of Items>: Number of registered tests (1 to 8)
<Item(n)Type>: The type of test registered in Item(n)
{TRAFFIC|QOS|BERT|PING|LOOPBACK}

:CONFIG:AUTO:MASTERSLAVE

Function Selects which device to configure and display the results of, either master or slave, for auto remote mode.

Syntax :CONFIG:AUTO:MASTERSLAVE{MASTER|SLAVE}

Example :CONFIG:AUTO:MASTERSLAVE MASTER
:CONFIG:AUTO:MASTERSLAVE?
->:CONFIG:AUTO:MASTERSLAVE MASTER

Description MASTER: Selects the configuration and results of the master.
SLAVE: Selects the configuration and results of the slave.

:CONFIG:AUTO:TRAFFIC:TXRATE

Function Sets the transmission rate of the traffic test.

Syntax :CONFIG:AUTO:TRAFFIC:TXRATE{<NRF>}
<NRF>: 0.00001 to 100 (0.00001 steps)

Example :CONFIG:AUTO:TRAFFIC:TXRATE 0.00001
:CONFIG:AUTO:TRAFFIC:TXRATE?
->:CONFIG:AUTO:TRAFFIC:TXRATE 0.00001

Description Selectable range: 0.00001 to 100.00000%

:CONFIG:AUTO:TRAFFIC:TXMODE

Function Sets the transmission mode.

Syntax :CONFIG:AUTO:TRAFFIC:TXMODE{CONTINUE|FRAMES|TIME}

Example :CONFIG:AUTO:TRAFFIC:TXMODE CONTINUE
:CONFIG:AUTO:TRAFFIC:TXMODE?
->:CONFIG:AUTO:TRAFFIC:TXMODE CONTINUE

Description CONTINUE: Mode in which frames are sent continuously. Once transmission is started, it continues until it is stopped.
FRAMES: Mode in which the specified number of frames are sent. When transmission is started, the specified number of frames are sent, and then transmission stops automatically.
TIME: Mode in which frames are sent over the specified length of time. When transmission is started, transmission takes place for the specified length of time and stops automatically.

4.3 CONFig Group

:CONFig:AUTO:TRAFfic:TXTime

Function Sets the transmission time when the transmission mode of the traffic test is set to time.

Syntax :CONFig:AUTO:TRAFfic:TXTime{<Nrf>}
<Nrf>: 1 to 1440

Example :CONFig:AUTO:TRAFfic:TXTime 1
:CONFig:AUTO:TRAFfic:TXTime?
->:CONFig:AUTO:TRAFfic:TXTime 1

Description Selectable range: 1 to 1440 minutes

:CONFig:AUTO:TRAFfic:TXFrames

Function Sets the number of frames when the transmission mode of the traffic test is set to frames.

Syntax :CONFig:AUTO:TRAFfic:TXFrames{<Nrf>}
<Nrf>: 1 to 4294967295

Example :CONFig:AUTO:TRAFfic:TXFrames 1
:CONFig:AUTO:TRAFfic:TXFrames?
->:CONFig:AUTO:TRAFfic:TXFrames 1

Description Selectable range: 1 to 4294967295

:CONFig:AUTO:TRAFfic:FRAMelength

Function Sets the Transmission frame length of the traffic test.

Syntax :CONFig:AUTO:TRAFfic:
FRAMelength{<Nrf>}
<Nrf>: 64 to 9999

Example :CONFig:AUTO:TRAFfic:FRAMELENGTH 64
:CONFig:AUTO:TRAFfic:FRAMELENGTH?
->:CONFig:AUTO:TRAFfic:FRAMELENGTH64

Description

VLAN	L2 and L3-IPv4 (bytes)	L3-IPv6 (bytes)
None	64 (64) to 9999 (9999)	74 (74) to 9999 (9999)
1 stack	64 (68) to 9999 (9999)	74 (78) to 9999 (9999)
2 stacks	64 (72) to 9999 (9999)	74 (82) to 9999 (9999)

* The value inside the parentheses indicates the actual Transmission frame length.

:CONFig:AUTO:TRAFfic:ACTuallength?

Function Displays the actual frame length of the specified frame of the traffic test.

Syntax :CONFig:AUTO:TRAFfic:ACTuallength?

Example :CONFig:AUTO:TRAFfic:ACTUALLLENGTH?
->:CONFig:AUTO:TRAFfic:
ACTUALLLENGTH72

Description See the :CONFig:AUTO:TRAFfic:FRAMelength command.

:CONFig:AUTO:TRAFfic:FILLpattern

Function Sets the fill pattern to insert in the payload area of the traffic test.

Syntax :CONFig:AUTO:TRAFfic:FILLpattern{ALL_0|ALL_1|ALTO_1|RANDOM}

Example :CONFig:AUTO:TRAFfic:FILLPATTERN
ALL_0
:CONFig:AUTO:TRAFfic:FILLPATTERN?
->:CONFig:AUTO:TRAFfic:FILLPATTERN
ALL_0

Description ALL_0: An all zero pattern is inserted.
ALL_1: An all one pattern is inserted.
ALTO_1: Alternating zeros and ones are inserted.
RANDOM: A random pattern is inserted.

:CONFig:AUTO:LOOPback:TARGet

Function Sets the loopback target frame of the loopback test.

Syntax :CONFig:AUTO:LOOPback:
TARGet{SOURCE|ALL}

Example :CONFig:AUTO:LOOPback:TARGet SOURCE
:CONFig:AUTO:LOOPback:TARGet?
->:CONFig:AUTO:LOOPback:TARGet
SOURCE

Description SOURCE: Only the frames addressed to the source are looped back.
ALL: All frames are looped back.

:CONFig:AUTO:QOS:TXMode

Function Sets the QoS test transmission mode.

Syntax :CONFig:AUTO:QOS:TXMode
{CONTINUE|FRAMES|TIME}

Example :CONFig:AUTO:QOS:TXMODE TIME
:CONFig:AUTO:QOS:TXMODE?
->:CONFig:AUTO:QOS:TXMODE TIME

Description CONTINUE: Mode in which frames are sent continuously. Once transmission is started, it continues until it is stopped.
FRAMES: Mode in which the specified number of frames are sent. When transmission is started, the specified number of frames are sent, and then transmission stops automatically.
TIME: Mode in frames are sent over the specified length of time. When transmission is started, transmission takes place for the specified length of time and stops automatically.

:CONFig:AUTO:QOS:TXTime

Function Sets the transmission time when the transmission mode of the QoS test is set to time.

Syntax :CONFig:AUTO:QOS:TXTime <Nrf>
<Nrf>: 1 to 1440

Example :CONFig:AUTO:QOS:TXTIME 10
:CONFig:AUTO:QOS:TXTIME?
->:CONFig:AUTO:QOS:TXTIME 10

Description Selectable range: 1 to 1440 minutes

:CONFIg:AUTO:QOS:TXFRAMES

Function Sets the number of frames when the transmission mode of the QoS test is set to frames.

Syntax :CONFIg:AUTO:QOS:TXFRAMES <NRF>
<NRF>: 1 to 4.3E+09

Example :CONFIg:AUTO:QOS:TXFRAMES 20
:CONFIg:AUTO:QOS:TXFRAMES?
->:CONFIg:AUTO:QOS:TXFRAMES 20

Description Selectable range: 1 to 4294967295

:CONFIg:AUTO:QOS:FIELD

Function Sets the QoS target field of the QoS test.

Syntax :CONFIg:AUTO:QOS:FIELD {FRAME_ID|VLAN1_ID|VLAN1_COS|VLAN2_ID|VLAN2_COS|IPV4_TOS|IPV4_DSCP|IPV6_TOS|IPV6_DSCP|L4_DP|L4_SP}

Example :CONFIg:AUTO:QOS:FIELD VLAN1_ID
:CONFIg:AUTO:QOS:FIELD?
->:CONFIg:AUTO:QOS:FIELD VLAN1_ID

:CONFIg:AUTO:QOS:CH<x>:ENABLE

Function Enables or disables CH<x> of the QoS test.

Syntax :CONFIg:AUTO:QOS:CH<x>:ENABLE
{ON|OFF}
<x>:1-4

ON: CH<x> of the QoS test is enabled.

OFF: CH<x> of the QoS test is disabled.

Example :CONFIg:AUTO:QOS:CH1:ENABLE ON
:CONFIg:AUTO:QOS:CH1:ENABLE?
->:CONFIg:AUTO:QOS:CH1:ENABLE 1

:CONFIg:AUTO:QOS:CH<x>:TXRATE

Function Sets the CH<NRF> test transmission rate of the QoS test.

Syntax :CONFIg:AUTO:QOS:CH<x>:TXRATE <NRF>
<x>:1-4
<NRF>: 0.0001 to 100

Example :CONFIg:AUTO:QOS:CH1:TXRATE 25
:CONFIg:AUTO:QOS:CH1:TXRATE?
->:CONFIg:AUTO:QOS:CH1:TXRATE
25.00000

Description Range: 0.00001 to 100.00000%

:CONFIg:AUTO:QOS:CH<x>:VALue

Function Sets the CH QoS value of the QoS test.

Syntax :CONFIg:AUTO:QOS:CH<x>:VALue <NRF>
<x>: 1-4
<NRF>: 0 to 65535

Example :CONFIg:AUTO:QOS:CH1:VALue 20
:CONFIg:AUTO:QOS:CH1:VALue?
->:CONFIg:AUTO:QOS:CH1:VALue 20

Description Selectable range: 0 to 65535

:CONFIg:AUTO:QOS:CH<x>:FRAMelength

Function Sets the transmission frame length of CH<x> of the QoS test.

Syntax :CONFIg:AUTO:QOS:CH<x>:FRAMelength
<NRF>
<x>: 1-4
<NRF>: 64 to 9999

Example :CONFIg:AUTO:QOS:CH1:FRAMelength 128
:CONFIg:AUTO:QOS:CH1:FRAMelength?
->:CONFIg:AUTO:QOS:CH1:FRAMelength
128

Description

VLAN	L2 and L3-IPv4 (bytes)	L3-IPv6 (bytes)
None	64 (64) to 9999 (9999)	74 (74) to 9999 (9999)
1 stack	64 (68) to 9999 (9999)	74 (78) to 9999 (9999)
2 stacks	64 (72) to 9999 (9999)	74 (82) to 9999 (9999)

* The value inside the parentheses indicates the actual Transmission frame length.

:CONFIg:AUTO:QOS:CH<x>:ACTUalLength?

Function Displays the actual transmission frame length of the specified frame of CH of the QoS test.

Syntax :CONFIg:AUTO:QOS:CH<x>:ACTUalLength?
<x>:1-4

Example :CONFIg:AUTO:QOS:CH1:ACTUalLength?
->:CONFIg:AUTO:QOS:CH1:ACTUalLength?
128

Description See the :CONFIg:AUTO:QOS:CH<x>:FRAMelength command.

:CONFIg:AUTO:QOS:FILLpattern

Function Sets the fill pattern to insert in the payload area of the QoS test.

Syntax :CONFIg:AUTO:QOS:FILLpattern {ALL_0|ALL_1|ALT0_1|RANDOM}

Example :CONFIg:AUTO:QOS:FILLpattern ALL_0
:CONFIg:AUTO:QOS:FILLpattern?
:CONFIg:AUTO:QOS:FILLpattern ALL_0

Description ALL_0: An all zero pattern is inserted.

ALL_1: An all one pattern is inserted.

ALT0_1: Alternating zeros and ones are inserted.

RANDOM: A random pattern is inserted.

4.3 CONFig Group

:CONFig:AUTO:PING:INTERval

Function Sets the PING test transmission interval.

Syntax :CONFig:AUTO:PING:INTERval{T1MS
|T10MS|T100MS|T1S}

Example :CONFIG:AUTO:PING:INTERVAL T1MS
:CONFIG:AUTO:PING:INTERVAL?
->:CONFIG:AUTO:PING:INTERVAL T1MS

Description T1MS: 1 ms
T10MS: 10 ms
T100MS: 100 ms
T1S: 1 s

:CONFig:AUTO:PING:TXMode

Function Sets the PING test transmission mode.

Syntax :CONFig:AUTO:PING:TXMode{CONTINUE|FR
AMES|TIME}

Example :CONFIG:AUTO:PING:TXMODE CONTINUE
:CONFIG:AUTO:PING:TXMODE?
->:CONFIG:AUTO:PING:TXMODE CONTINUE

Description CONTINUE: Mode in which frames are sent continuously. Once transmission is started, it continues until it is stopped.
FRAMES: Mode in which the specified number of frames are sent. When transmission is started, the specified number of frames are sent, and then transmission stops automatically.
TIME: Mode in which frames are sent over the specified length of time. When transmission is started, transmission takes place for the specified length of time and stops automatically.

:CONFig:AUTO:PING:TXTime

Function Sets the transmission time in unit of minutes when the transmission mode of the PING test is set to time.

Syntax :CONFig:AUTO:PING:TXTime{<Nrf>}
<Nrf>: 1 to 1440

Example :CONFIG:AUTO:PING:TXTIME 1
:CONFIG:AUTO:PING:TXTIME?
->:CONFIG:AUTO:PING:TXTIME1

Description Selectable range: 1 to 1440 minutes

:CONFig:AUTO:PING:TXFRames

Function Sets the number of frames when the transmission mode of the PING test is set to frames.

Syntax :CONFig:AUTO:PING:TXFRames{<Nrf>}
<Nrf>: 1 to 4294967295

Example :CONFIG:AUTO:PING:TXFRAMES 1
:CONFIG:AUTO:PING:TXFRAMES?
->:CONFIG:AUTO:PING:TXFRAMES 1

Description Selectable range: 1 to 4294967295

:CONFig:AUTO:PING:FRAMelength

Function Sets the Transmission frame length of the PING test.

Syntax :CONFig:AUTO:PING:FRAMelength{<Nrf>}
<Nrf>: 64 to 9999

Example :CONFIG:AUTO:PING:FRAMELENGTH 64
:CONFIG:AUTO:PING:FRAMELENGTH?
->:CONFIG:AUTO:PING:FRAMELENGTH 64

Description
VLAN L2 and L3-IPv4 (bytes) L3-IPv6 (bytes)
None 64 (64) to 9999 (9999) 74 (74) to 9999 (9999)
1 stage 64 (68) to 9999 (9999) 74 (78) to 9999 (9999)
2 stages 64 (72) to 9999 (9999) 74 (82) to 9999 (9999)
* The value inside the parentheses indicates the actual Transmission frame length.

:CONFig:AUTO:PING:ACTUallength?

Function Displays the actual frame length of the specified frame of the PING test.

Syntax :CONFig:AUTO:PING:ACTUallength?
Example :CONFIG:AUTO:PING:ACTUALLENGTH?
->:CONFIG:AUTO:PING:ACTUALLENGTH72

Description See the :CONFig:AUTO:PING:FRAMelength command.

:CONFig:AUTO:BERT:TXRate

Function Sets the BERT test transmission rate.

Syntax :CONFig:AUTO:BERT:TXRate{<Nrf>}
<Nrf>: 0.00001 to 100 (0.00001 steps)

Example :CONFIG:AUTO:BERT:TXRATE 0.00001
:CONFIG:AUTO:BERT:TXRATE?
->:CONFIG:AUTO:BERT:TXRATE 0.00001

Description Selectable range: 0.00001 to 100.00000%

:CONFig:AUTO:BERT:TXMode

Function Sets the BERT test transmission mode.

Syntax :CONFig:AUTO:BERT:TXMode{CONTINUE|FR
AMES|TIME}

Example :CONFIG:AUTO:BERT:TXMODE CONTINUE
:CONFIG:AUTO:BERT:TXMODE?
->:CONFIG:AUTO:BERT:TXMODE CONTINUE

Description CONTINUE: Mode in which frames are sent continuously. Once transmission is started, it continues until it is stopped.
FRAMES: Mode in which the specified number of frames are sent. When transmission is started, the specified number of frames are sent, and then transmission stops automatically.
TIME: Mode in which frames are sent over the specified length of time. When transmission is started, transmission takes place for the specified length of time and stops automatically.

:CONFig:AUTO:BERT:TXTime

Function Sets the transmission time when the transmission mode of the BERT test is set to time.

Syntax :CONFig:AUTO:BERT:TXTime{ <NRf> }
<NRf>: 1 to 1440

Example :CONFig:AUTO:BERT:TXTIME1
:CONFig:AUTO:BERT:TXTIME?
->:CONFig:AUTO:BERT:TXTIME1

Description Selectable range: 1 to 1440 minutes

:CONFig:AUTO:BERT:TXFrames

Function Sets the number of frames when the transmission mode of the BERT test is set to frames.

Syntax :CONFig:AUTO:BERT:TXFrames{ <NRf> }
<NRf>: 1 to 4294967295

Example :CONFig:AUTO:BERT:TXFRAMES 1
:CONFig:AUTO:BERT:TXFRAMES?
->:CONFig:AUTO:BERT:TXFRAMES1

Description Selectable range: 1 to 4294967295

:CONFig:AUTO:BERT:FRAMelength

Function Sets the Transmission frame length of the BERT test.

Syntax :CONFig:AUTO:BERT:FRAMelength{ <NRf> }
<NRf>: 64 to 9999

Example :CONFig:AUTO:BERT:FRAMELENGTH64
:CONFig:AUTO:BERT:FRAMELENGTH?
->:CONFig:AUTO:BERT:FRAMELENGTH64

Description

VLAN	L2 and L3-IPv4 (bytes)	L3-IPv6 (bytes)
None	64 (64) to 9999 (9999)	74 (74) to 9999 (9999)
1 stage	64 (68) to 9999 (9999)	74 (78) to 9999 (9999)
2 stages	64 (72) to 9999 (9999)	74 (82) to 9999 (9999)

* The value inside the parentheses indicates the actual Transmission frame length.

:CONFig:AUTO:BERT:ACTuallength?

Function Displays the actual frame length of the specified frame of the BERT test.

Syntax :CONFig:AUTO:BERT:ACTuallength?

Example :CONFig:AUTO:BERT:ACTUALLENGTH?
-> :CONFig:AUTO:BERT:ACTUALLENGTH
72

Description See the :CONFig:AUTO:BERT:FRAMelength command.

4.4 INBand Group

The commands in this group deal with auto remote inband control.

:INBand:CONNECT

Function Connects or disconnects the measurement on the slave side during auto remote mode.

Syntax :INBand:CONNECT{CONNECT|RELEASE}

Example :INBAND:CONNECT CONNECT
:INBAND:CONNECT?
->:INBAND:CONNECT CONNECT

Description CONNECT: Connects the slave device.
RELEASE: Disconnects the slave device.
In a query, the current connection status is indicated.

4.5 CONTROL Group

The commands in this group are used to control measurements.

:CONTROL:MEASURE

Function Starts or stops measurement.

Syntax :CONTROL:MEASURE {START|STOP}

Example :CONTROL:MEASURE START
:CONTROL:MEASURE?
->:CONTROL:MEASURE START

Description START: Starts measurement.
STOP: Stops measurement.

:CONTROL:TRANSMIT

Function Starts or stops the transmission of test frames.

Syntax :CONTROL:TRANSMIT {START|STOP}

Example :CONTROL:TRANSMIT START
:CONTROL:TRANSMIT?
->:CONTROL:TRANSMIT START

Description START: Starts transmission.
STOP: Stops transmission.

:CONTROL:NEXT

Function Executes the next test when the AQ1300/AQ1301 is ready to execute the next test.

Syntax :CONTROL:NEXT

Example :CONTROL:NEXT

:CONTROL:STATUS?

Function Displays the current measurement execution status.

Syntax :CONTROL:STATUS?

Example :CONTROL:STATUS?
->:CONTROL:STATUS 1, EXECUTING

Description Response data: <current test ItemNo>,<{STOP|EXECUTING|PAUSE}>
<current Test No>: The number of the test item being executed (1 to 8)
<{STOP|EXECUTING|PAUSE}>: Test execution status
STOP: The test is stopped.
EXECUTING: The test is in execution.
PAUSE: Waiting to start the next test.

4.6 RESULT:COUNTER Group

The commands in this group are used to display counter values.

:RESULT:COUNTER:COMMON?

Function Displays all counter values in the common group. You can also display a specific counter.

Syntax :RESULT:COUNTER:COMMON?
Counter values without measurement results appear as "NaN."

Individual display commands

:RESULT:COUNTER:COMMON:TIME?	[Common] Acquisition time
:RESULT:COUNTER:COMMON:DURATION?	[Common] Measurement time

:RESULT:COUNTER:LINK?

Function Displays all counter values in the link group. You can also display a specific counter.

Syntax :RESULT:COUNTER:LINK?
Counter values without measurement results appear as "NaN."

Individual display commands

:RESULT:COUNTER:LINK:STATUS?	[Link] Link status
:RESULT:COUNTER:LINK:LASEROFF?	[Link] The number of times the laser has been turned off
:RESULT:COUNTER:LINK:LINKDOWN?	[Link] Number of link down detection
:RESULT:COUNTER:LINK:TXFREQDEV?	[Link] Transmission clock frequency deviation (ppm)
:RESULT:COUNTER:LINK:RXFREQDEV?	[Link] Reception clock frequency deviation (ppm)
:RESULT:COUNTER:LINK:LFSSEND?	[Link] LF transmission count
:RESULT:COUNTER:LINK:RFSEND?	[Link] RF transmission count
:RESULT:COUNTER:LINK:LFDetect?	[Link] LF detection count
:RESULT:COUNTER:LINK:RFDetect?	[Link] RF detection count
:RESULT:COUNTER:LINK:LFRxcolumn?	[Link] Number of received LF columns
:RESULT:COUNTER:LINK:RFRxcolumn?	[Link] Number of received RF columns
:RESULT:COUNTER:LINK:SYLOSS?	[Link] 66B sync loss count
:RESULT:COUNTER:LINK:SYERROR?	[Link] 66B sync error count
:RESULT:COUNTER:LINK:SYHIBER?	[Link] 66B Sync hi-ber Count

:RESULT:COUNTER:TX?

Function Displays all counter values in the transmission group. You can also display a specific counter.

Syntax :RESULT:COUNTER:TX?
Counter values without measurement results appear as "NaN."

Individual display commands

:RESULT:COUNTER:TX:FRAME?	[Tx] Number of normal frames
:RESULT:COUNTER:TX:BYTE?	[Tx] Number of bytes
:RESULT:COUNTER:TX:RATE?	[Tx] Rate (%)
:RESULT:COUNTER:TX:FPS?	[Tx] Rate (frame/s)
:RESULT:COUNTER:TX:BTSP?	[Tx] Rate (byte/s)
:RESULT:COUNTER:TX:BPS?	[Tx] Rate (bps)
:RESULT:COUNTER:TX:REPLYFRAME?	[Tx] Number of reply frames
:RESULT:COUNTER:TX:ERRFRAME?	[Tx] Number of error frames
:RESULT:COUNTER:TX:CRCErr?	[Tx] Number of CRC error frames
:RESULT:COUNTER:TX:UNDERSIZE?	[Tx] Number of undersized frames
:RESULT:COUNTER:TX:OVERSIZE?	[Tx] Number of oversized frames
:RESULT:COUNTER:TX:SYMBOLERR?	[Tx] Number of symbol error frames

:RESult:COUNTer:RX?

Function Displays all counter values in the reception group. You can also display a specific counter.

Syntax :RESult:COUNTer:RX?

Counter values without measurement results appear as "NaN."

Individual display commands

:RESult:COUNTer:RX:FRAME?	[Rx] Number of normal frames
:RESult:COUNTer:RX:BYTE?	[Rx] Number of bytes
:RESult:COUNTer:RX:RATE?	[Rx] Rate (%)
:RESult:COUNTer:RX:FPS?	[Rx] Rate (frame/s)
:RESult:COUNTer:RX:BTPS?	[Rx] Rate (byte/s)
:RESult:COUNTer:RX:BPS?	[Rx] Rate (bps)
:RESult:COUNTer:RX:PEKRate?	[Rx] Peak rate (%)
:RESult:COUNTer:RX:PEKFps?	[Rx] Peak rate (frame/s)
:RESult:COUNTer:RX:PEKBps?	[Rx] Peak rate (bps)
:RESult:COUNTer:RX:AVGRate?	[Rx] Average rate (%)
:RESult:COUNTer:RX:AVGFps?	[Rx] Average rate (frame/s)
:RESult:COUNTer:RX:AVGBps?	[Rx] Average rate (bps)
:RESult:COUNTer:RX:PAUSEframe?	[Rx] Number of pause frames
:RESult:COUNTer:RX:COLLision?	[Rx] Number of detected collisions
:RESult:COUNTer:RX:ERRFrame?	[Rx] Number of error frames

:RESult:COUNTer:RXError?

Function Displays all counter values in the reception error group. You can also display a specific counter.

Syntax :RESult:COUNTer:RXError:CRCErr?

Counter values without measurement results appear as "NaN."

Individual display commands

:RESult:COUNTer:RXError:CRCErr?	[Rx error] CRC error Number of frames
:RESult:COUNTer:RXError:UNDersize?	[Rx error] Number of undersized frames
:RESult:COUNTer:RXError:OVERsize?	[Rx error] Number of oversized frames
:RESult:COUNTer:RXError:ALIGNmenterr?	[Rx error] Number of alignment error frames
:RESult:COUNTer:RXError:SYMBOLerr?	[Rx error] Symbols Number of error frames

:RESult:COUNTer:LATency?

Function Displays all counter values in the delay group. You can also display a specific counter.

Syntax :RESult:COUNTer:LATency?

Counter values without measurement results appear as "NaN."

Individual display commands

:RESult:COUNTer:LATency:MAXifg?	[Delay] Maximum interframe gap (us)
:RESult:COUNTer:LATency:MINifg?	[Delay] Minimum interframe gap (us)
:RESult:COUNTer:LATency:AVGifg?	[Delay] Average interframe gap (us)
:RESult:COUNTer:LATency:MAXLatency?	[Delay] Maximum packet delay time (us)
:RESult:COUNTer:LATency:MINLatency?	[Delay] Minimum packet delay time (us)
:RESult:COUNTer:LATency:AVGLatency?	[Delay] Average packet delay time (us)
:RESult:COUNTer:LATency:MAXBitifg?	[Delay] Maximum interframe gap (bit)
:RESult:COUNTer:LATency:MINBitifg?	[Delay] Minimum interframe gap (bit)
:RESult:COUNTer:LATency:AVGBitifg?	[Delay] Average interframe gap (bit)

:RESult:COUNTer:SEquence?

Function Displays all counter values in the sequence group. You can also display a specific counter.

Syntax :RESult:COUNTer:SEquence?

Counter values without measurement results appear as "NaN."

Individual display commands

:RESult:COUNTer:SEquence:LOSSpacket?	[Sequence] Number of loss packets
:RESult:COUNTer:SEquence:REOrder?	[Sequence] Number of reorder packets
:RESult:COUNTer:SEquence:DUPLicate?	[Sequence] Number of duplicate packets
:RESult:COUNTer:SEquence:MAXBurstloss?	[Sequence] Max burst loss number

:RESult:COUNTer:PAYLoad?

Function Displays all counter values in the payload group. You can also display a specific counter.

Syntax :RESult:COUNTer:PAYLoad?

Counter values without measurement results appear as "NaN."

Individual display commands

:RESult:COUNTer:PAYLoad:PAYLoaderr?	[Payload] Number of payload errors
-------------------------------------	------------------------------------

4.6 :RESult:COUNter Group

:RESult:COUNter:CH<x>Tx?

Function Displays all counter values in the CH<x>Tx group. You can also display a specific counter.

Syntax :RESult:COUNter: COUNter:CH<x>Tx?
<x>:1-8
Counter values without measurement results appear as "NaN."

Individual display commands

:RESult:COUNter:CH<x>Tx:FRAME?	[CH<x>Tx] Number of normal frames
:RESult:COUNter:CH<x>Tx:BYTE?	[CH<x>Tx] Number of bytes
:RESult:COUNter:CH<x>Tx:RATE?	[CH<x>Tx]Rate(%)
:RESult:COUNter:CH<x>Tx:FPS?	[CH<x>Tx]Rate(frame/s)
:RESult:COUNter:CH<x>Tx:BPS?	[CH<x>Tx]Rate(bps)

:RESult:COUNter:CH<x>Rx?

Function Displays all counter values in the CH<x>Rx group. You can also display a specific counter.

Syntax :RESult:COUNter: COUNter:CH<x>Rx?
<x>:1-8
Counter values without measurement results appear as "NaN."

Individual display commands

:RESult:COUNter:CH<x>Rx:FRAME?	[CH<x>Rx] Number of normal frames
:RESult:COUNter:CH<x>Rx:BYTE?	[CH<x>Rx] Number of reception bytes
:RESult:COUNter:CH<x>Rx:RATE?	[CH<x>Rx]Rate (%)
:RESult:COUNter:CH<x>Rx:FPS?	[CH<x>Rx] Rate (frame/s)
:RESult:COUNter:CH<x>Rx:BPS?	[CH<x>Rx] Rate (bps)
:RESult:COUNter:CH<x>Rx:PEKRate?	[CH<x>Rx] Peak rate (%)
:RESult:COUNter:CH<x>Rx:PEKFps?	[CH<x>Rx] Peak rate (frame/s)
:RESult:COUNter:CH<x>Rx:PEKBps?	[CH<x>Rx] Peak rate (bps)
:RESult:COUNter:CH<x>Rx:AVGRate?	[CH<x>Rx] Average rate (%)
:RESult:COUNter:CH<x>Rx:AVGFps?	[CH<x>Rx] Average rate (frame/s)
:RESult:COUNter:CH<x>Rx:AVGBps?	[CH<x>Rx] Average rate (bps)
:RESult:COUNter:CH<x>Rx:MAXLatency?	[CH<x>Rx] Maximum packet delay time (us)
:RESult:COUNter:CH<x>Rx:MINLatency?	[CH<x>Rx] Minimum packet delay time (us)
:RESult:COUNter:CH<x>Rx:AVGLatency?	[CH<x>Rx] Average packet delay time (us)
:RESult:COUNter:CH<x>Rx:LOSSpacket?	[CH<x>Rx] Number of loss packets
:RESult:COUNter:CH<x>Rx:REOrder?	[CH<x>Rx] Number of reorder packets
:RESult:COUNter:CH<x>Rx:DUPLicate?	[CH<x>Rx] Number of duplicate packets
:RESult:COUNter:CH<x>Rx:MAXBurstloss?	[CH<x>Rx] Max burst loss number
:RESult:COUNter:CH<x>Rx:PAYLoaderr?	[CH<x>Rx] Number of payload errors

:RESult:COUNter:BERT?

Function Displays all counter values in the BERT group. You can also display a specific counter.

Syntax :RESult:COUNter:BERT?
Counter values without measurement results appear as "NaN."

Individual display commands

:RESult:COUNter:BERT:ERRRate?	[BERT] Bit error rate (x10-12)
:RESult:COUNter:BERT:ERRCount?	[BERT] Number of bit errors
:RESult:COUNter:BERT:ERRFrame?	[BERT] Number of bit error frames
:RESult:COUNter:BERT:SYNCloss?	[BERT] BERT sync loss count
:RESult:COUNter:BERT:TARGetbyte?	[BERT] BERT target byte
:RESult:COUNter:BERT:BITerrinsert?	[BERT] Bit error insertion

:RESult:COUNter:PING?

Function Displays all counter values in the PING group. You can also display a specific counter.

Syntax :RESult:COUNter:PING?
Counter values without measurement results appear as "NaN."

Individual display commands

:RESult:COUNter:PING:SENDcount?	[PING] Number of tests
:RESult:COUNter:PING:LOSSCount?	[PING] Number of losses
:RESult:COUNter:PING:ARPer?	[PING] Number of ARP errors
:RESult:COUNter:PING:IPV4err?	[PING] Number of IP errors
:RESult:COUNter:PING:ICMPerr?	[PING] Number of ICMP errors
:RESult:COUNter:PING:TIMEout?	[PING] Timeout
:RESult:COUNter:PING:LOSSRate?	[PING] Loss rate (%)
:RESult:COUNter:PING:MAXResponse?	[PING] Maximum response time (ms)
:RESult:COUNter:PING:MINResponse?	[PING] Minimum response time (ms)
:RESult:COUNter:PING:AVGResponse?	[PING] Average response time (ms)

4.7 COMMunicate Group

The commands in this group deal with system communication.

:COMMunicate:HEADer

Function Sets or queries whether a header is added to the response to a query (example with header: ":INBand:CONNect CONNECT"; example without header: "CONNECT").

Syntax :COMMunicate:HEADer{<Boolean>
:COMMunicate:HEADer?

Example :COMMUNICATE:HEADER ON
:COMMUNICATE:HEADER?->:COMM:HEAD1

:COMMunicate:VERBose

Function Sets or queries whether the response to a query is returned fully spelled out (e.g., :INBand:CONNect CONNECT) or in its abbreviated form (e.g., INB:CONN CONNECT).

Syntax :COMMunicate:VERBose{<Boolean>
:COMMunicate:VERBose?

Example :COMMUNICATE:VERBOSE ON
:COMMUNICATE:VERBOSE?->:COMM:VERB 0

:COMMunicate:TELNet:ERRor

Function Sets the error display timing for Telnet connection.

Syntax :COMMunicate:TELNet:ERRor
NORMAL | IMMEDIATE
:COMMunicate:TELNet:ERRor?

Example :COMMUNICATE:TELNET:ERROR IMMEDIATE
:COMMUNICATE:TELNET:ERROR?
->COMMUNICATE:TELNET:ERROR IMMEDIATE

Description **NORMAL** The error is displayed when it is queried with the :STATus:ERRor? error command.
IMMEDIATE The error is displayed immediately when the command is executed.

4.8 STATUS Group

The commands in this group deal with system communication status.

:STATUS:ERROR?

Function Queries the error code and message of the last error that has occurred (top of the error queue).

Syntax :STATUS:ERROR?

Example :STATUS:ERROR?->113,"Undefined header"

:STATUS:QMESSAGE

Function Sets or queries whether message information will be attached to the response to the STATUS:ERROR? query.

Syntax :STATUS:QMESSAGE{<Boolean>}

:STATUS:QMESSAGE?

Example :STATUS:QMESSAGE OFF

:STATUS:QMESSAGE?->:STATUS:QMESSAGE 1

5.1 Output and Error Queue

Output Queue

The output queue stores query response messages. As shown below, data is stored in order and read from the oldest message first. The output queue is cleared when the AQ1300/AQ1301 is turned off and then back on.

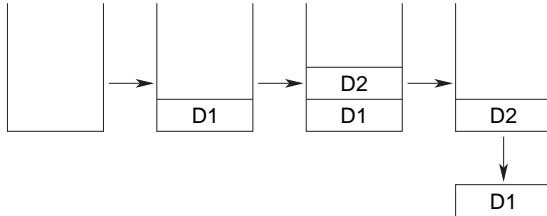

Error Queue

When an error occurs, the error queue stores the error number and message. For example, if the AQ1300/AQ1301 receives an incorrect program message from the controller, the error number (113) and the error message (“Undefined header”) are stored in the error queue when the AQ1300/AQ1301 displays the error message.

You can use the `:STATUS:ERROR?` query to read the contents of the error queue. Like the output queue, the messages in the error queue are read from the oldest one first.

If the error queue overflows, the last message is replaced with the following message: 350, “Queue overflow”

The error queue is cleared when:

- The AQ1300/AQ1301 is turned off and then back on.

Appendix Error Messages

This section describes error messages. Errors can be divided into two types: communication errors that the AQ1300/AQ1301 communication server generates and function errors that the AQ1300/AQ1301 measurement application generates. These errors are explained in detailed below. For information on how to query error messages, see the description in the STATus group commands.

Communication Errors

Communication errors are generated by the AQ1300/AQ1301 communication server or command parser. The following errors are available.

Error No	Message	Description
102	Syntax error.	-
113	Undefined header.	-
141	Invalid character data.	-
222	Data out of range.	-
223	Data invalid.	-
350	Queue overflow.	-

Function Errors

Function errors are generated by the AQ1300/AQ1301 measurement application. Some errors occur at the time of command execution, and others occur when the status changes. The following errors are available.

Errors That Occur at the Time of Command Execution

- **Errors That Occur When a Setting Is Changed**

Error No	Message	Description
1298	Settings conflict.	There is a conflict with other settings.

- **Errors That Occur When a Measurement Is Started**

Error No	Message	Description
8	Error Address Resolution.	ARP/NDP address resolution failed.
9	Now Linkdown.	The link is down.
30	The Source IP address is not got yet.	The source IP address has not been obtained. Before starting the test, obtain an IP address on the Link/Address Source Address setup screen.
1284	The control to the destination machine failed.	Measurement/transmission control on the other device failed. The other device may not be displaying the measured results.
1285	Same as above	Same as above

- **Inband Remote Errors**

Error No	Message	Description
14	Fail inband connection.	-
1277	Connection Timeout.	-
1276	Bad Password.	-
1290	The system version of the destination is mismatch.	-

Appendix Error Messages

• Setup File Load and Result File Save Errors

Error No	Message	Description
1257	Cannot be loaded.	-
1260	Unreadable setup/result file.	-
1261	Save Error.	-
1262	load Error.	-
1264	Detect Bad Container.	An abnormal container was detected in the file. The file may be corrupt.
1273	Load Error(Bad Measurement Type)(This File is for "Auto")	-
1274	Load Error(Bad Measurement Type)(This File is for "Auto(Remote)")	-
1275	Load Error(Bad Measurement Type)(This File is for "Manual")	-
1292	Load Error(Bad Measurement Type)(This File is for "RFC2544")	-
1295	This File is for "10G". The test interface was changed into SFP from XFP.	-
1291	Cannot make measurement result file, because measurement data doesn't exist.	-

• Other Errors

Error No	Message	Description
1272	Fail Getting Address.	Address acquisition through DHCP or stateless autoconfiguration failed.

Errors That Occur When the Status Changes

• Errors That Occur during Measurement

Error No	Message	Description
10	Detect Linkdown while Stating.	A linkdown condition was detected during measurement, so the measurement was stopped.
11	Detect L2Error while Stating.	An L2 error was detected during measurement, so the measurement was stopped.
12	Detect L3Error while Stating.	An L3 error was detected during measurement, so the measurement was stopped.
28	Detect result Fail.	A measurement failure was detected during measurement, so the measurement was stopped.

• Errors That Occur During Inband Remote Connection

Error No	Message	Description
1280	Inband Session is disconnected.	-

• System Errors (1/2)

Error No	Message
5001	System Error.
5002	FPGA Configuration Error.
5003	FAN Alarm.
5004	Detect Bad Clock.
5005	Detect Bad Optical Module.
5006	Battery is low Please power it off, and charge the battery or replace the battery. Or, please use the AC power supply.
5007	Backup battery failed, and needs to be repaired. Please contact Yokogawa's representatives.
5008	Battery is low The instrument will be powered off in 10 sec.
5010	The temperature inside the instrument is too high. The instrument may be damaged if it is kept using in this condition. The instrument will be powered off in 10 sec. Please do not power it on till the battery is cooled down.
5011	The temperature inside the instrument is too low. The instrument may be damaged if it is kept using in this condition. The instrument will be powered off in 10 sec. Please do not power it on till the battery is cooled down.

• System Errors (2/2)

Error No	Message
5012	The temperature inside the instrument is too high. The instrument may be damaged if it is kept using in this condition. The instrument will be powered off in 10 sec. Please do not power it on till the battery is cooled down.
5013	The temperature inside the instrument is too low. The instrument may be damaged if it is kept using in this condition. The instrument will be powered off in 10 sec. Please do not power it on till the battery is cooled down.
5014	The Voltage of AC power supply is too low. The instrument may be damaged if it is kept using in this condition. The instrument will be powered off in 10 sec. Please make sure of using the dedicated AC adapter.
5015	The Voltage of AC power supply is too high. The instrument may be damaged if it is kept using in this condition. The instrument will be powered off in 10 sec. Please make sure of using the dedicated AC adapter.

Index

Symbol

<Boolean>	3-6
<Character Data>	3-6
<Decimal>	3-5
<Distance>	3-5
<Loss>	3-5
<Multiplier>	3-5
<PMT>	3-1
<Program Message Unit>	3-1
<RMT>	3-1
<String Data>	3-6
<Time>	3-5
<Unit>	3-5
<Wavelength>	3-5

A

Abbreviated Form	3-4
------------------------	-----

C

Command	3-3
Command Groups	3-3
Compound Header	3-3

D

Data	3-1, 3-5
------------	----------

E

Error Queue	5-1
Ethernet Interface	2-2

H

Header	3-1
--------------	-----

M

Messages	3-1
Message Unit	3-1
mini B	1-3

O

Output Queue	5-1
--------------------	-----

P

PMT	3-1
Port number	2-2
Program Messages	3-1

Q

query	3-1
-------------	-----

R

Releasing the Remote Control (Ethernet)	2-4
Releasing the Remote Control (USB)	1-4
Response Data	3-1
RMT	3-1

S

shortest abbreviation	3-3
STP cable	2-3
Switching from Local to Remote Mode (Ethernet)	2-2
Switching from Local to Remote Mode (USB)	1-2
Switching from Remote to Local Mode (Ethernet)	2-2
Switching from Remote to Local Mode (USB)	1-2

T

TCP/IP	2-5
Timeout Value	2-5
type B	1-3

U

Upper-level Query	3-3
USB connector type B (mini B)	1-3
USB Interface	1-2
UTP cable	2-3