

---

**User's  
Manual**

**IR200/IR400 Infrared Gas Analyzer  
Communication Functions (MODBUS)**

IM 11G02P01-01E

---

# Introduction

---

This manual describes the communication function of model IR200 or IR400 Infrared Gas Analyzer.

Read this manual and understand Modbus communication specification before using this function.

Regarding main analyzer, refer IMs below.

For model IR200; IM 11G02M01-01E

For model IR400; IM 11G02N01-01E

# Notices

---

## ■ Regarding This Manual

- This manual should be passed on to the end user.
- Read this manual carefully and fully understand how to operate this product before you start operation.
- This manual is intended to explain the functions of this product. Yokogawa Electric Corporation (hereinafter simply referred to as Yokogawa) does not warrant that the functions will suit a particular purpose of the user.
- All rights reserved. No part of this document may be reproduced in any form without Yokogawa's written permission.
- The contents of this manual are subject to change without prior notice.
- If any question arises or errors are found, or if any information is missing from this manual, please inform the nearest Yokogawa sales office.

## ■ Regarding Protection, Safety, and Prohibition Against Unauthorized Modification

- For the protection and safe use of the product and the system controlled by it, be sure to follow the instructions on safety described in this manual when handling the product.
- If protection/safety circuits are to be used with the product or the system controlled by it, they should be installed outside of the product.

## ■ Regarding Force Majeure

- Yokogawa makes no warranties regarding the product except those mentioned in the WARRANTY that is provided separately.
- In cases where the use of this product results in damage or loss to the user or a third party, Yokogawa will not be responsible for any incidental or consequential damage or loss, or any damage or loss suffered by the user or third party resulting from a defect or defects in this product which could not be foreseen by Yokogawa.

## ■ Regarding the Software Supplied by Yokogawa

- Yokogawa makes no warranties regarding the product except those mentioned in the WARRANTY that is provided separately.
- Use this software with one specified computer only. You must purchase another copy of the software for use with each additional computer.
- Copying this software for purposes other than backup is strictly prohibited.
- Store the floppy disk(s) or the streamer tape (original medium) containing this software in a secure place. Yokogawa may not be able to assure the Yokogawa-specified quality level of the product nor may be able to provide the Yokogawa-specified maintenance service in the event the user does not have the original medium.
- Reverse engineering such as the disassembly or decompilation of software is strictly prohibited.
- No portion of the software supplied by Yokogawa may be transferred, exchanged, or sublet or leased for use by any third party without the prior permission of Yokogawa.

## After-sales Warranty

---

- The warranty shall cover the period noted on the quotation presented to the Purchaser at the time of purchase. The Purchaser shall receive the Seller's warranted services in accordance with the Seller's provisions. The Purchaser shall be charged, even during the warranty period, for expenses arising from the dispatch of engineering personnel from the Seller to locations other than those specified by the Seller to repair the purchased product in question.
- The Purchaser shall bear the responsibility for repair costs, even during the warranty period, if the malfunction is due to:
  - failure of a part or parts indicated in the instruction manual or other literature as not covered by this warranty.
  - use of software, hardware or spare parts not supplied by the Seller.
  - improper and/or inadequate maintenance by the Purchaser.
  - retrofitting, overuse, misuse, or erroneous operation by the Purchaser not conforming to the standards approved by the Seller.
  - malfunction or damage from improper relocation of the product in question after delivery.
  - use of a power supply (voltage and/or frequency) not specified by the Seller or due to a failure in the power supply.
  - use of the product in question in a location not conforming to the standards specified by the Seller, or due to improper maintenance of the installation location.
  - reason of force majeure such as fires, earthquakes, storms/floods, thunder/lightening, or other natural disasters, or disturbances, riots, warfare, or radioactive contamination.
- The Seller shall not guarantee the suitability of the purchased product to any particular application of the Purchaser. Nor shall the Seller be liable for any damage to the product, direct or indirect, resulting from such an application.
- The Seller shall not be liable for any damage, direct or indirect, inflicted on the purchased product at any premises of the end user in the case where the Purchaser reassembles the purchased product into another product to transfer to the end user or resells the purchased product to the end user.

# CONTENTS

---

1. COMMUNICATION FUNCTIONS .....	1
1.1 General.....	1
2. SPECIFICATIONS .....	2
2.1 Communication specifications.....	2
3. CONNECTION.....	3
3.1 Terminal allocation .....	3
3.2 Connection.....	3
4. SETTING OF COMMUNICATION CONDITION.....	4
4.1 Set items.....	4
4.2 Setting operation.....	4
5. MODBUS COMMUNICATION PROTOCOL.....	5
5.1 General.....	5
5.2 Composition of message .....	6
5.3 Response of slave station.....	8
5.4 Function code.....	9
5.5 Calculation of error check code (CRC-16) .....	10
5.6 Transmission control procedure.....	12
6. DETAILS OF MESSAGE .....	14
6.1 Read-out of word data [Function code:03 <sub>H</sub> ] .....	14
6.2 Read-out of read only word data [Function code:04 <sub>H</sub> ] .....	16
6.3 Write-in of word data (1 word) [Function code:06 <sub>H</sub> ].....	18
6.4 Write-in of continuous word data [Function code:10 <sub>H</sub> ] .....	19
7. ADDRESS MAP AND DATA FORMAT .....	21
7.1 Data format .....	21
7.2 Address map .....	23
7.3 Supplement to address map .....	32
8 . SAMPLE PROGRAM .....	34
9. TROUBLESHOOTING.....	40



# 1. COMMUNICATION FUNCTIONS

## 1.1 General

- This instrument provides a communication function through RS-232 interface, which allows data transmit to or receive from the host computer and other devices.
- The communication system is comprised of a master station and slave stations. One slave station (this instrument) can be connected to one master station.  
It is also possible to adapt the instrument to the environment of RS-485 interface using RS-232 ↔ RS-485 converter. In this case, up to 31 of slave station (present instrument) can be connected per master station.
- Because the master station can communicate with only one slave station at a time, the destination can be identified by the "Station No" set for each slave station.
- In order that the master station and the slave station can communicate, the format of the transmit/receive data must coincide. In this instrument, the format of the communication data is determined by the MODBUS protocol.

[RS-232 ↔ RS-485 converter] (recommended article)

Type: KS-485 (non-isolated type)/SYSTEM SACOM Corp.

Type: SI-30A (isolated type)/SEKISUI ELECTRONICS Co., Ltd.

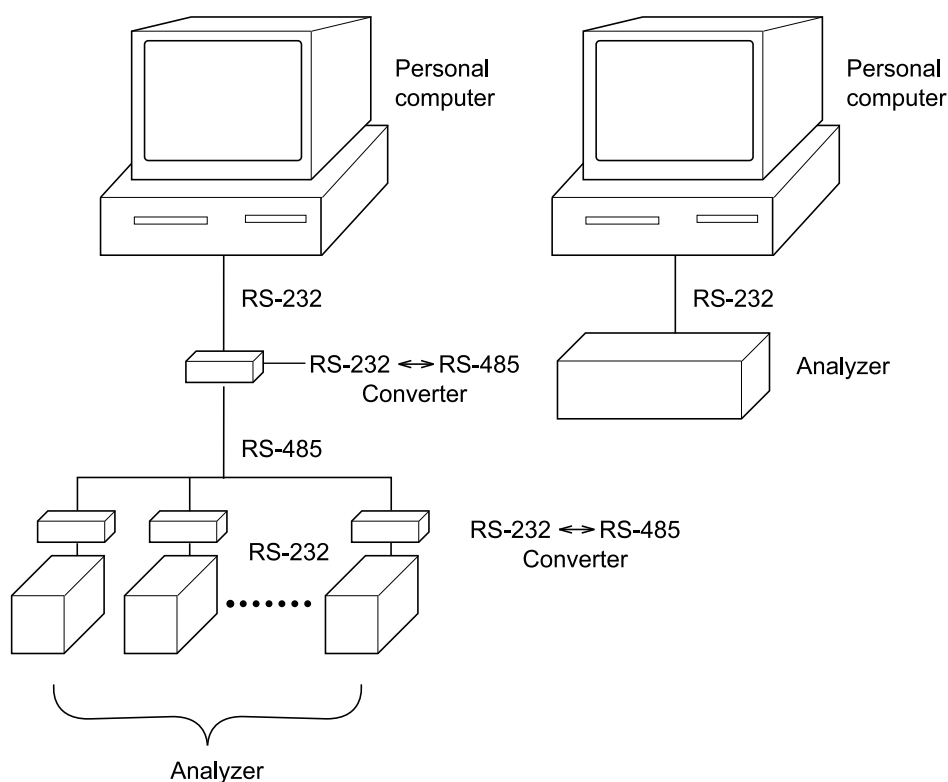

## 2. SPECIFICATIONS

---

### 2.1 Communication specifications

Item	Specification	
Electrical specification	Based on EIA RS-232	
Transmission system	2-wire, semi-duplicate	
Synchronizing system	Start-stop synchronous system	
Connection format	1 : 1	
Number connectable units	1 unit (or 31 if RS-485 interface is used)	
Transmission speed	9600bps	
Data format	Data length	8 bits
	Stop bit	1 bit
	Parity	None
	X flow control	None
Transmission code	HEX value (MODBUS RTU mode)	
Error detection	CRC-16	
Isolation	No isolation between transmission circuit and others	



### 3. CONNECTION

**⚠ WARNING**

For avoiding electric shock and malfunctions, do not turn on the power supply until all wiring have been completed.

#### 3.1 Terminal allocation (Input/output terminal CN2)

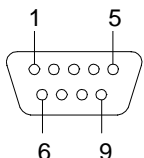
Terminal number	Signal name	Pin connection
2	Recive Data	
3	Transmit Data	
5	Signal GND	
Others	NC	

9-pin D-Sub  
(male)

#### 3.2 Connection

As connecting cable, use a commercially available RS-232 reverse cable.

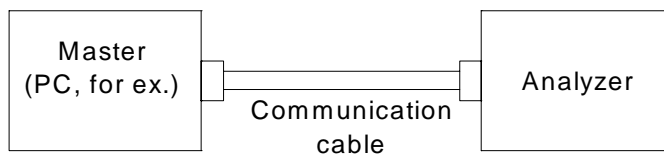

Connect the cable to CN2 on the input/output terminal block (on rear for model IR200, separate for model IR400).

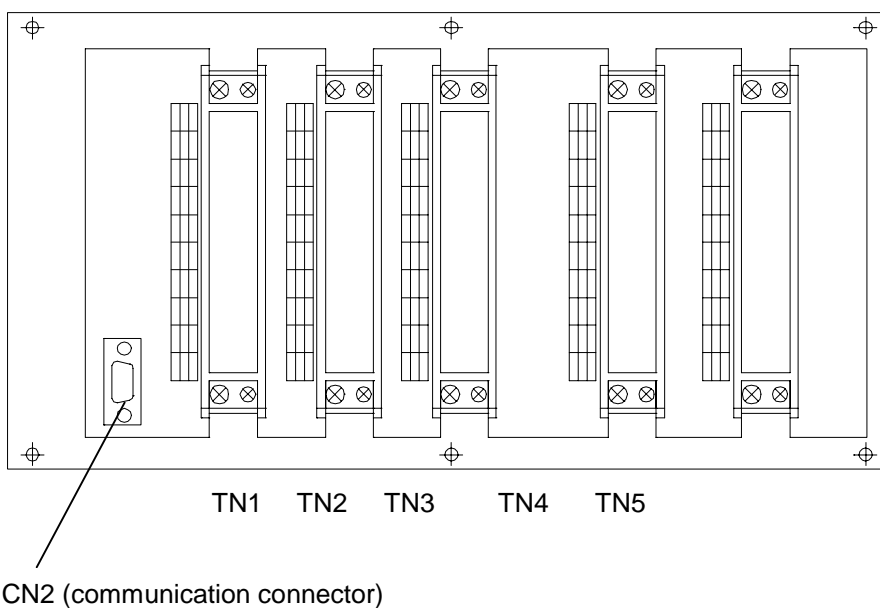

## 4. SETTING OF COMMUNICATION CONDITION

---

In order that the master station and instrument can correctly communicate, following settings are required.

- All communication condition settings of the master station are the same as those of instruments.
- All instruments connected on a line are set to "Station Nos. (STno)" which are different from each other. (Any "Station No." is not shared by more than one instrument.)

### 4.1 Set items

The parameters to be set are shown in the following table. Set them by operating the front panel keys.

Item	Value at delivery	Setting range	Remarks
Transmission speed	9600bps	Fixed (can not be changed)	Set the same communication condition to the master station and all slave stations.
Data length	8 bits	Fixed (can not be changed)	
Stop bit	1 bit	Fixed (can not be changed)	
Parity setting	None	Fixed (can not be changed)	
Station No.	1	0 to 31 (0:communication function stop)	Set a different value to each station.

### 4.2 Setting operation

Set the station No. on the analyzer maintenance mode display (see the instruction manual below).

For model IR200; IM 11G02M01-01E

For model IR400; IM 11G02N01-01E

# 5. MODBUS COMMUNICATION PROTOCOL

---

## 5.1 General

The communication system by the MODBUS protocol is that the communication is always started from the master station and a slave station responds to the received message.

Transmission procedures is as shown below.

- 1) The master station sends a command message to a slave station.
- 2) The slave station checks that the station No. in the received message matches with the own station No. or not.
- 3) If matched, the slave station executes the command and sends back the response message.
- 4) If mismatched, the slave station leaves the command message and wait for the next command message.

- a) In case when the station No. in the received command message matches with the own slave station No.

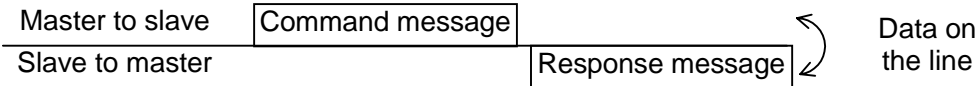

- b) In case when the station No. in the received command message mismatches with the own slave station No.

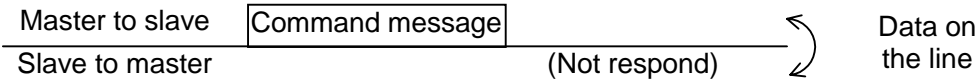

The master station can individually communicate with any one of slave stations connected on the same line upon setting the station No. in the command message.

---

## 5.2 Composition of message

Command message and response message consist of 4 fields ; Station No., Function code, Data and Error check code. And these are send in this order.

Station No. (1 byte)
Function code (1 byte)
Data (2 to 133 bytes)
Error check code (CRC-16) (2 bytes)

**Fig. 5-1 Composition of message**

In the following, each field is explained.

### (1) Station No.

Station No. is the number specifying a slave station. Only a slave station that corresponds to a value to which "Station No." is set on the analyzer maintenance mode display executes a command.

### (2) Function code

This is a code to designate the function executed at a slave station.  
For details, refer to section 5.4.

### (3) Data

Data are the data required for executing function codes. The composition of data varies with function codes. For details, refer to chapter 6.

A register number is assigned to each data in the analyzer. For reading/writing the data by communication, designate the register number.

Note that the register number transmitted on message is expressed as its relative address.  
The relative address is calculated by the following expression.

$$\boxed{\text{Relative address}} = \left( \text{The lower 4 digits of the } \boxed{\text{Register number}} \right) - 1$$

For example, when the register number designated by a function code is 40003,

$$\begin{aligned} \text{Relative address} &= (\text{lower 4 digits of } 40003) - 1 \\ &= 0002 \end{aligned}$$

is used on the message.

---

#### **(4) Error check code**

This is the code to detect message errors (change in bit) in the signal transmission.  
On the MODBUS protocol (RTU mode), CRC-16 (Cyclic Redundancy Check) is applied.

For CRC calculation method, refer to section 5.5.

---

## 5.3 Response of slave station

### (1) Response for normal command

To a relevant message, the slave station creates and sends back a response message which corresponds to the command message. The composition of message in this case is the same as in section 5.2.

Contents of the data field depend on the function code. For details, refer to Chapter 6.

### (2) Response for abnormal command

If contents of a command message have an abnormality (for example, non-actual function code is designated) other than transmission error, the slave station does not execute that command but creates and sends back a response message at error detection.

The composition of response message at error detection is as shown in Fig. 5-2. The value used for function code field is function code of command message plus 80<sub>H</sub>.

Table 5-1 gives error codes.

Station No.
Function code + 80 <sub>H</sub>
Error code
Error check(CRC-16)

**Fig. 5-2 Response message at error detection**

**Table 5-1 Error code**

Error code	Contents	Description
01H	Illegal function	Non-actual function code is designated. Check for the function code.
02H	Illegal data address	A relative address of a register number to which the designated function code can not be used.
03H	Illegal data value	Because the designation of number is too much, the area where register numbers do not exist is designated.

### (3) No response

Under any of the following items, the slave station takes no action of the command message and sends back no response.

- A station number transmitted in the command message differs from the station number specified to the slave station.
- A error check code is not matched, or a transmission error (parity error, etc.) is detected.
- The time interval between the composition data of the message becomes longer than the time corresponding to 24 bits. (Refer to section 5.6 Transmission control procedure)

## 5.4 Function code

According to MODBUS protocol, register numbers are assigned by function codes.  
Each function code acts on specific register number.

This correspondence is shown in Table 5-2, and the message length by function is shown in Table 5-3.

**Table 5-2 Correspondence between function codes and objective address**

Function code			Register No.	
No.	Function	Object	No.	Contents
03 <sub>H</sub>	Read-out (continuously)	Holding register	4xxxx	Read-out/write-in word data
04 <sub>H</sub>	Read-out (continuously)	Input register	3xxxx	Read-out word data
06 <sub>H</sub>	Write-in	Holding register	4xxxx	Read-out/write-in word data
10 <sub>H</sub>	Write-in (continuously)	Holding register	4xxxx	Read-out/write-in word data

**Table 5-3 Function code and message length**

[Unit : byte]

Function code	Contents	Number of designatable data	Command message		Response message	
			Minimum	Maximum	Minimum	Maximum
03 <sub>H</sub>	Read-out of word data	60 words	8	8	7	133
04 <sub>H</sub>	Read-out of word data (read-out only)	15 words	8	8	7	133
06 <sub>H</sub>	Write-in of word data	1 word	8	8	8	8
10 <sub>H</sub>	Write-in of continuous word data	60 words	11	137	8	8

## 5.5 Calculation of error check code (CRC-16)

CRC-16 is the 2-byte (16-bits) error check code. From the top of the message (station No.) to the end of the data field are calculated.

The slave station calculates the CRC of the received message, and does not respond if the calculated CRC is different from the contents of the received CRC code.

The following shows the calculation procedure for CRC-16.

- (a) Store FFFF<sub>H</sub> into 16 bit register (CRC register).
- (b) Subject the 1st byte (8 bits) of transmit message and CRC register contents to an exclusive logical summation (XOR), and store the result into the CRC register.
- (c) Shift the CRC register contents 1 bit to the right. Store 0 at MSB.
- (d) If LSB before shifting is 0, do nothing.  
If LSB before shifting is 1, subject it and A001H to XOR, and store the result into the CRC register.
- (e) Repeat the steps (c) and (d) 8 times (shift by 8 bits).
- (f) Execute steps (b) to (e) for the next byte of the transmit message.  
Likewise, successively repeat the steps to each byte of the transmit message.
- (g) The CRC code that is retained is the value of CRC register that stands when the processing has ended for latest byte (latest data except error code) of the transmit message.
- (h) As error check code of the transmit message, store this CRC value in the order of lower 8 bits and upper 8 bits.

Transmit message (ex.)

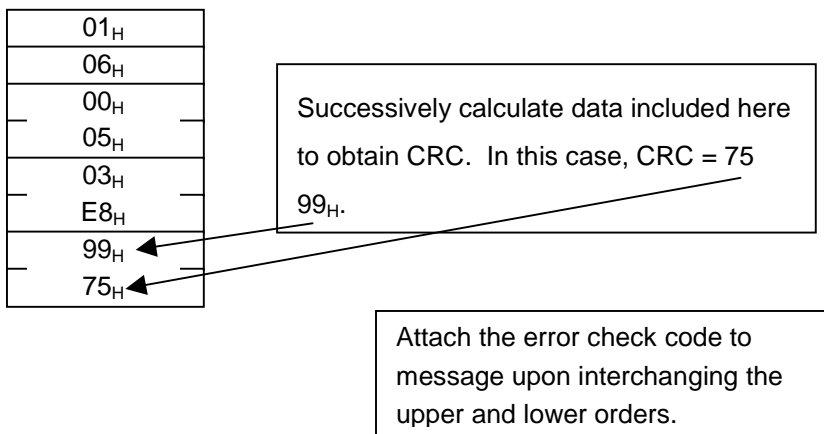
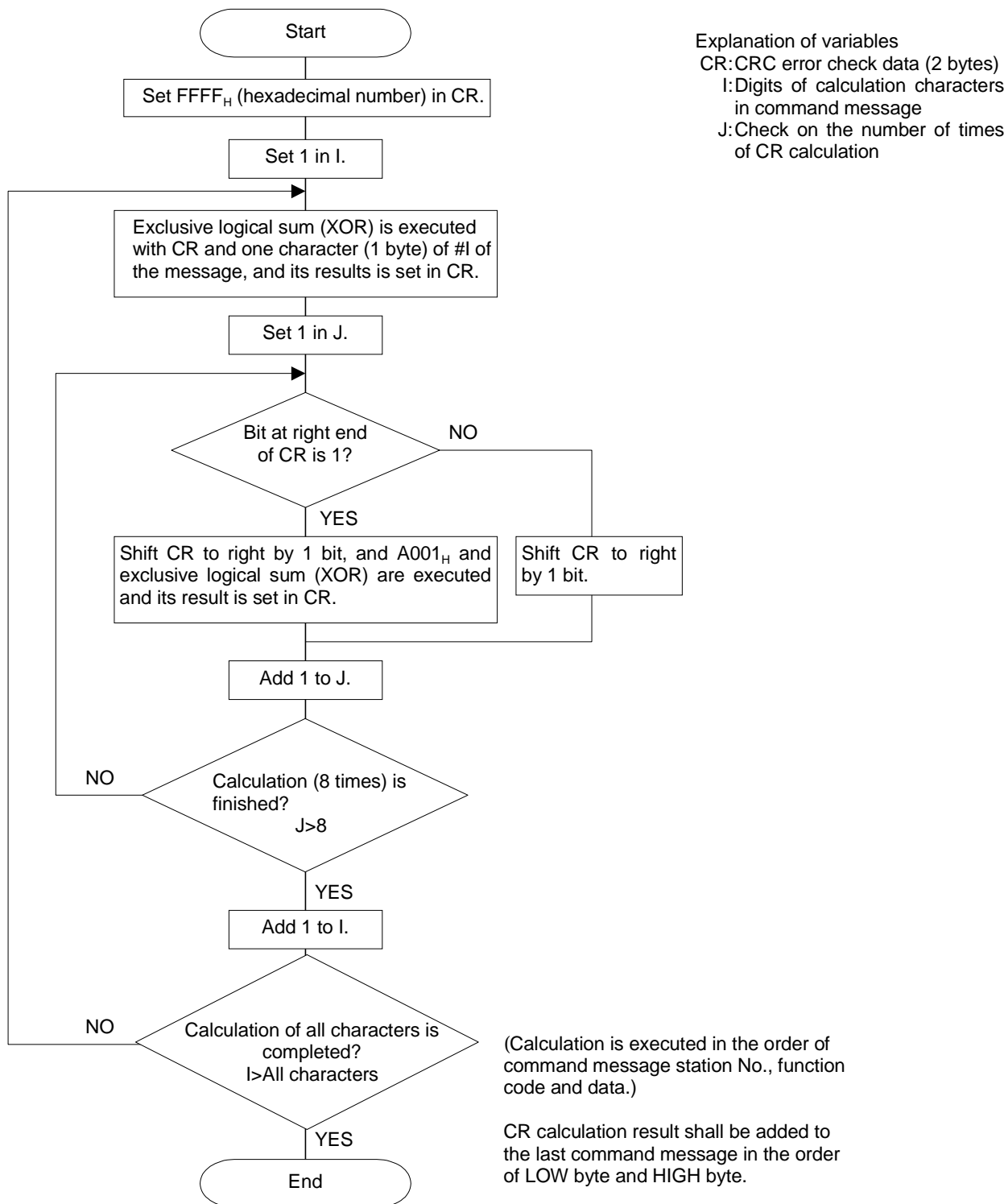

Fig. 5-3 shows the flow of the CRC-16 calculation system.





**Fig. 5-3 Flow of CRC-16 calculation**

---

## 5.6 Transmission control procedure

### (1) Transmission procedure of master station

The master station must proceed to a communication upon conforming to the following items.

- (1-1) Before sending a command message, provide 48 bits time or more vacant status.
- (1-2) For sending, the interval between bytes of a command message is below 24 bits time.
- (1-3) Within 24 bits time after sending a command message, the receiving status is posted.
- (1-4) Provide 48 bits time or more vacant status between the end of response message reception and beginning of next command message sending [same as in (1-1)].
- (1-5) For ensuring the safety, make a confirmation of the response message and make an arrangement so as to provide 3 times or more retries in case of no response, error occurrence, etc.

Note) The above definition is for most unfavorable value. For ensuring the safety, it's recommended the program of the master to work with safety factors of 2 to 3. Concretely, it is advised to arrange the program for 9600 bps with 10 ms or more for vacant status (1-1), and within 1 ms for byte interval (1-2) and changeover from sending to receiving (1-3).

### (2) Description

#### 1) Detection of the message frame

The status on the line of the communication system is one of the 2 below.

- (a) Vacant status (no data on line)
- (b) Communication status (data is existing)

Instruments connected on the line are initially at a receiving status and monitoring the line. When 24 bits time or more vacant status has appeared on the line, the end of preceding frame is assumed and, within following 24 bits time, a receiving status is posted. When data appears on the line, instruments receive it while 24 bits time or more vacant status is detected again, and the end of that frame is assumed. I.e., data which appeared on the line from the first 24 bits time or more vacant status to the next 24 bits time or more vacant status is fetched as one frame.

Therefore, one frame (command message) must be sent upon confirming the following.

- (1-1) 48 bits time or more vacant status precedes before the command message sending.
- (1-2) Interval between bytes of 1 command message is smaller than 24 bits time.

#### 2) Response of this instrument

After a frame detection (24 bits time or more vacant status), this instrument carries out processing with that frame as a command message. If the command message is destined to the own station, a response message is returned. Its processing time is 1 to 30 ms (depends on contents of command message). After sending a command message, therefore, the master station must observe the following.

- (1-3) Receiving status is posted within 24 bits time after sending a command message.

---

Space time of longer than 5ms is needed  
(longer than 10ms is recommended)

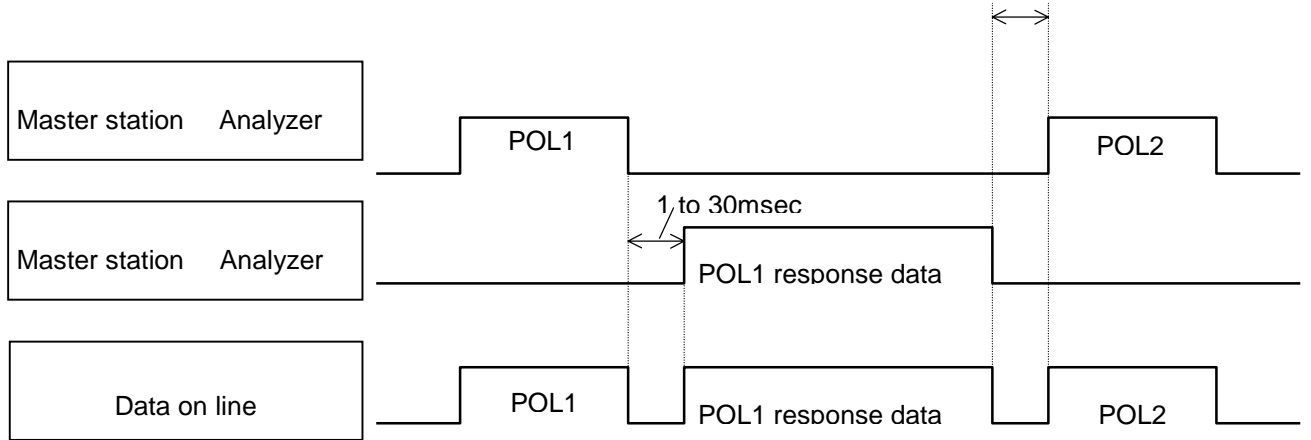

## 6. DETAILS OF MESSAGE

### 6.1 Read-out of word data [Function code:03<sub>H</sub>]

Function code	Max. word number read-out in one message	Relative data address	Register No.	Contents
03 <sub>H</sub>	64 words	0000 <sub>H</sub> 006D <sub>H</sub>	40001 40110	User setting

#### (1) Message composition

Command message composition (byte)

Station No.	
Function code	
Read-out start No. (relative address)	Upper
	Lower
Read-out word number	Upper
	Lower
CRC data	Lower
	Upper

} 1 to 64

Response message composition (byte)

Station No.	
Function code	
Read-out byte number	
Contents of the first word data	Upper
	Lower
Contents of the next word data	Upper
	Lower
-----	
Contents of the last word data	Upper
	Lower
CRC data	Lower
	Upper

Read-out word number×2

\* Arrangement of read-out word data

MSB	LSB
Upper byte of contents of the first word data	
Lower byte of contents of the first word data	
Upper byte of contents of the next word data	
Lower byte of contents of the next word data	
-----	
Upper byte of contents of the last word data	
Lower byte of contents of the last word data	

#### (2) Function explanations

Word data of continuous word numbers from the read-out start No. can be read. Read-out word data are transmitted from the slave station in the order of upper and lower bytes.

### (3) Message transmission (example)

The following shows an example of reading out from No. 1 station the setting CH2 (2nd component) range-1 zero and span calibration concentration.

Relative address of CH2 range-1 zero calibration concentration setting: 0004<sub>H</sub> Data number: 02<sub>H</sub>

Command message composition (byte)

Station No.		01 <sub>H</sub>
Function code		03 <sub>H</sub>
Read-out start No. (relative address)	Upper	00 <sub>H</sub>
	Lower	04 <sub>H</sub>
Read-out word number	Upper	00 <sub>H</sub>
	Lower	02 <sub>H</sub>
CRC data	Lower	85 <sub>H</sub>
	Upper	CA <sub>H</sub>

Response message composition (byte)

Station No.		01 <sub>H</sub>
Function code		03 <sub>H</sub>
Read-out byte number		04 <sub>H</sub>
Contents of the first word data	Upper	00 <sub>H</sub>
	Lower	00 <sub>H</sub>
Contents of the next word data	Upper	03 <sub>H</sub>
	Lower	E8 <sub>H</sub>
CRC data	Lower	FA <sub>H</sub>
	Upper	8D <sub>H</sub>

\* Meaning of read-out data

CH2 range-1 zero calibration concentration setting    00 00<sub>H</sub> = 0  
(contents of first word data)

CH2 range-1 span calibration concentration setting    03 E8<sub>H</sub> = 1000  
(contents of next word data)

Provided decimal point position = 1, measurement unit = 1,

CH2 range-1 zero calibration concentration = 0.0 ppm

CH2 range-1 span calibration concentration = 100.0 ppm



For handling of decimal point and unit, refer to Section 7.1.

## 6.2 Read-out of read only word data [Function code:04<sub>H</sub>]

Function code	Max. word number read-out in one message	Relative data address	Resister No.	Contents
04 <sub>H</sub>	64 words	0000 <sub>H</sub> 00BD <sub>H</sub>	30001 30190	Measurement value and status
		0425 <sub>H</sub> 0447 <sub>H</sub>	31062 31096	Fixed setting

### (1) Message composition

Command message composition (byte)

Station No.	
Function code	
Read-out start No. (relative address)	Upper
	Lower
Read-out word number	Upper
	Lower
CRC data	Lower
	Upper

Response message composition (byte)

Station No.		Read-out word number×2
Function code		
Read-out byte number		
Contents of the first word data	Upper	
	Lower	
Contents of the next word data	Upper	
	Lower	
—		
Contents of the last word data	Upper	
	Lower	
CRC data	Lower	
	Upper	

\* Arrangement of read-out word data

MSB	LSB
Upper byte of contents of the first word data	
Lower byte of contents of the first word data	
Upper byte of contents of the next word data	
Lower byte of contents of the next word data	
—	
Upper byte of contents of the last word data	
Lower byte of contents of the last word data	

### (2) Function explanations

Word data of continuous word numbers from the read-out start No. can be read. Read-out word data are transmitted from the slave station in the order of upper and lower bytes.

### (3) Message transmission (example)

The following shows an example of reading out from No. 1 station the CH5 measurement concentration, decimal point position and measurement unit.

Relative address of CH5 measurement concentration: 000C<sub>H</sub> Data number: 03<sub>H</sub>

Command message composition (byte)

Station No.		01 <sub>H</sub>
Function code		04 <sub>H</sub>
Read-out start No. (relative address)	Upper	00 <sub>H</sub>
	Lower	0C <sub>H</sub>
Read-out word number	Upper	00 <sub>H</sub>
	Lower	03 <sub>H</sub>
CRC data	Lower	70 <sub>H</sub>
	Upper	08 <sub>H</sub>

Response message composition (byte)

Station No.		01 <sub>H</sub>
Function code		04 <sub>H</sub>
Read-out byte number		06 <sub>H</sub>
Contents of the first word data	Upper	04 <sub>H</sub>
	Lower	B0 <sub>H</sub>
Next word data contents	Upper	00 <sub>H</sub>
	Lower	02 <sub>H</sub>
Latest word data contents	Upper	00 <sub>H</sub>
	Lower	00 <sub>H</sub>
CRC data	Lower	81 <sub>H</sub>
	Upper	0D <sub>H</sub>

\* Meaning of read-out data

First word data contents      04 B0<sub>H</sub> = 1200  
 Next word data contents      00 02<sub>H</sub> = 2 (decimal point position)  
 Latest word data contents    00 00<sub>H</sub> = 0 (vol %)

In the above case, measurement concentration = 12.00 vol%



For handling of decimal point and unit, refer to Section 7.1.

### 6.3 Write-in of word data (1 word) [Function code:06<sub>H</sub>]

Function code	Max. word number write-in in one message	Relative data address	Resister No.	Contents
06 <sub>H</sub>	1 word	0000 <sub>H</sub> 006D <sub>H</sub>	40001 40110	User setting
		07D0 <sub>H</sub> 07D1 <sub>H</sub>	42001 42002	Operation command

#### (1) Message composition

Command message composition (byte)

Station No.	
Function code	
Write-in designate No. (relative address)	Upper
	Lower
Write-in word data	Upper
	Lower
CRC data	Lower
	Upper

Response message composition (byte)

Station No.	
Function code	
Write-in designate No. (relative address)	Upper
	Lower
Write-in word data	Upper
	Lower
CRC data	Lower
	Upper

#### (2) Function explanation

Designated word data is written in write-in designate No. Write-in data are transmitted from master station in the order of upper and lower bytes.

#### (3) Message transmission (example)

The following shows an example of transmitting the "ZERO" key command to No. 1 station.  
Key operation command Relative address: 07D0<sub>H</sub>

Command message composition (byte)

Station No.		01 <sub>H</sub>
Function code		06 <sub>H</sub>
Write-in designate No. (relative address)	Upper	07 <sub>H</sub>
	Lower	D0 <sub>H</sub>
Write-in word data	Upper	00 <sub>H</sub>
	Lower	40 <sub>H</sub>
CRC data	Lower	88 <sub>H</sub>
	Upper	B7 <sub>H</sub>

} ZERO key command

Response message composition (byte)

Station No.		01 <sub>H</sub>
Function code		06 <sub>H</sub>
Write-in designate No. (relative address)	Upper	07 <sub>H</sub>
	Lower	D0 <sub>H</sub>
Write-in word data	Upper	00 <sub>H</sub>
	Lower	40 <sub>H</sub>
CRC data	Lower	88 <sub>H</sub>
	Upper	B7 <sub>H</sub>



## 6.4 Write-in of continuous word data [Function code:10<sub>H</sub>]

Function code	Max. word number write-in in one message	Relative data address	Resister No.	Kind of data
10 <sub>H</sub>	64 words	0000 <sub>H</sub> 006D <sub>H</sub>	40001 40110	User setting

### (1) Message composition

Command message composition (byte)

Station No.	
Function code	
Write-in start No. (relative address)	Upper
	Lower
Write-in word number	Upper
	Lower
Write-in byte number	
First write-in word data	Upper
	Lower
Next write-in word data	Upper
	Lower
Last write-in word data	Upper
	Lower
CRC data	Lower
	Upper

} 1 to 64

} Write-in word number×2

Response message composition (byte)

Station No.	
Function code	
Write-in start No. (relative address)	Upper
	Lower
Write-in word number	Upper
	Lower
CRC data	Lower
	Upper

\* Arrangement of write-in word data

MSB	LSB
Upper byte of contents of the first word data	
Lower byte of contents of the first word data	
Upper byte of contents of the next word data	
Lower byte of contents of the next word data	
Upper byte of contents of the last word data	
Lower byte of contents of the last word data	

### (2) Function explanation

Word data of continuous word number is written from write-in start address. Write-in word data are transmitted from master station in the order of upper and lower bytes.

### (3) Message transmission (example)

The following shows an example of writing the CH1 (1st component) alarm settings to No. 1 station.

CH1 range-1 high alarm setting = 1388<sub>H</sub> (= 5000<sub>D</sub>)

CH1 range-1 low alarm setting = 000A<sub>H</sub> (= 10<sub>D</sub>)

CH1 range-2 high alarm setting = 03E8<sub>H</sub> (= 1000<sub>D</sub>)

CH1 range-2 low alarm setting = 000A<sub>H</sub> (= 10<sub>D</sub>)

CH1 range-1 high alarm setting Relative address: 0023<sub>H</sub> Data number: 04<sub>H</sub>

Command message composition (byte)

Station No.	01 <sub>H</sub>	
Function code	10 <sub>H</sub>	
Write-in start No.	Upper	00 <sub>H</sub>
	Lower	23 <sub>H</sub>
Write-in word number	Upper	00 <sub>H</sub>
	Lower	04 <sub>H</sub>
Write-in byte number	08 <sub>H</sub>	
First write-in word data	Upper	13 <sub>H</sub>
	Lower	88 <sub>H</sub>
Next write-in word data	Upper	00 <sub>H</sub>
	Lower	0A <sub>H</sub>
Next write-in word data	Upper	03 <sub>H</sub>
	Lower	E8 <sub>H</sub>
Last write-in word data	Upper	00 <sub>H</sub>
	Lower	0A <sub>H</sub>
CRC data	Lower	E2 <sub>H</sub>
	Upper	A6 <sub>H</sub>

Response message composition (byte)

Station No.	01 <sub>H</sub>	
Function code	10 <sub>H</sub>	
Write-in start No.	Upper	00 <sub>H</sub>
	Lower	23 <sub>H</sub>
Write-in word number	Upper	00 <sub>H</sub>
	Lower	04 <sub>H</sub>
CRC data	Lower	30 <sub>H</sub>
	Upper	00 <sub>H</sub>



Since the transmission data can not include a decimal point, data of 500.0 is transmitted as "5000".

For transmission format of each data, refer to the Address map (Chapter 7).

## 7. ADDRESS MAP AND DATA FORMAT

---

### 7.1 Data format

#### 7.1.1 Transmission data format

The MODBUS protocol used in this instrument is RTU (Remote Terminal Unit) mode. Transmitted data is "numeric value" and not ASCII code".

#### 7.1.2 Handling of decimal point position and measurement unit

When transmitted, the calibration concentration setting, alarm's high and low limits and measurement concentration data have no decimal point nor measurement unit.

Calculate exact values of data upon point positioning as shown below.

- (a) Calibration concentration setting (register No. 40001 to 40020)  
Alarm setting (register No. 40036 to 40055)

You can know the point position for each CH (channel) and each range, and unit upon reading in the decimal point position data (register No. 31087 to 31096), and the unit data (register No. 31067 to 31076).

The decimal point position data has a value of 0, 1, 2 or 3. You can obtain an exact value by the following calculation.

- Case 0: Calibration concentration setting data /1
- Case 1: Calibration concentration setting data /10
- Case 2: Calibration concentration setting data /100
- Case 3: Calibration concentration setting data /1000

The unit data has a value of 0, 1, 2 or 3, that corresponds as follows.

- Case 0: vol%
- Case 1: ppm
- Case 2: mg/m<sup>3</sup>
- Case 3: g/m<sup>3</sup>

For example, if:

- CH1 range-1 span calibration concentration setting (register No. 40002) = 2000,
- CH1 range-1 decimal point position (register No. 31087) = 1, and
- CH1 range-1 unit (register No. 31067) = 1,

the value is 200.0 ppm.

For writing-in, proceed in the reverse. To obtain 200.0 ppm, write 2000 as calibration concentration setting.

The decimal point position and unit are unchangeable because fixed to each CH and each range.

---

(b) Measurement concentration (register No. 30001 to 30036)

The decimal point position and measurement unit for each concentration are stored in registers following that of concentration, and can be known by reading them in.

The meaning of decimal point position data and measurement unit data values are the same as in (a) above.

For example, if:

CH3 measurement concentration (register No. 30007) = 1270,

CH3 decimal point position (register No. 30008) = 2,

CH3 measurement unit (register No. 30009) = 0,

the value is 12.70 vol%

### 7.1.3 Handling at measurement data over-range

Even if the measurement data is at over-range, with "— — — —" displayed on the screen, the concentration that stands then is transmitted as read-out measurement concentration.

## 7.2 Address map

For details of functions and settable ranges of different parameters, refer to the instruction manual for the analyzer. Relevant model: 2; for model IR200, 4; for model IR400.

**Word data [read-out/write-in]: Function code [03<sub>H</sub>, 06<sub>H</sub>, 10<sub>H</sub>]**

### User settings

Relative address	Register No.	Data type	Memory contents	Read-out/write-in data	Remarks or corresponding parameter	Relevant model
0000 <sub>H</sub>	40001	Word	CH1 range-1 zero calibration concentration	0 to 9999	Calibration value	2/4
0001 <sub>H</sub>	40002	Word	CH1 range-1 span calibration concentration	Decimal point position depends on range		2/4
0002 <sub>H</sub>	40003	Word	CH1 range-2 zero calibration concentration			2/4
0003 <sub>H</sub>	40004	Word	CH1 range-2span calibration concentration			2/4
0004 <sub>H</sub>	40005	Word	CH2 range-1 zero calibration concentration			2/4
0005 <sub>H</sub>	40006	Word	CH2 range-1 span calibration concentration			2/4
0006 <sub>H</sub>	40007	Word	CH2 range-2 zero calibration concentration			2/4
0007 <sub>H</sub>	40008	Word	CH2 range-2 span calibration concentration			2/4
0008 <sub>H</sub>	40009	Word	CH3 range-1 zero calibration concentration			2/4
0009 <sub>H</sub>	40010	Word	CH3 range-1 span calibration concentration			2/4
000A <sub>H</sub>	40011	Word	CH3 range-2 zero calibration concentration			2/4
000B <sub>H</sub>	40012	Word	CH3 range-2 span calibration concentration			2/4
000C <sub>H</sub>	40013	Word	CH4 range-1 zero calibration concentration			2/4
000D <sub>H</sub>	40014	Word	CH4 range-1 span calibration concentration			2/4
000E <sub>H</sub>	40015	Word	CH4 range-2 zero calibration concentration			2/4
000F <sub>H</sub>	40016	Word	CH4 range-2 span calibration concentration			2/4
0010 <sub>H</sub>	40017	Word	CH5 range-1 zero calibration concentration			4
0011 <sub>H</sub>	40018	Word	CH5 range-1 span calibration concentration	4		
0012 <sub>H</sub>	40019	Word	CH5 range-2 zero calibration concentration	4		
0013 <sub>H</sub>	40020	Word	CH5 range-2 span calibration concentration	4		

**Word data [read-out/write-in]: Function code [03<sub>H</sub>, 06<sub>H</sub>, 10<sub>H</sub>]**

**User settings**

Relative address	Register No.	Data type	Memory contents	Read-out/write-in data	Remarks or corresponding parameter	Relevant model
0014 <sub>H</sub>	40021	Word	CH1 auto calibration switch	0, 1  (0: Do not calibrate in auto calibration 1: Calibrate in auto calibration)	Auto calibration component	2/4
0015 <sub>H</sub>	40022	Word	CH2 auto calibration switch			2/4
0016 <sub>H</sub>	40023	Word	CH3 auto calibration switch			2/4
0017 <sub>H</sub>	40024	Word	CH4 auto calibration switch			2/4
0018 <sub>H</sub>	40025	Word	CH5 auto calibration switch			4
0019 <sub>H</sub>	40026	Word	CH1 zero calibration switch	0,1  (0: Selectable zero calibration, 1: Zero calibration at once)	About zero calibration	2/4
001A <sub>H</sub>	40027	Word	CH2 zero calibration switch			2/4
001B <sub>H</sub>	40028	Word	CH3 zero calibration switch			2/4
001C <sub>H</sub>	40029	Word	CH4 zero calibration switch			2/4
001D <sub>H</sub>	40030	Word	CH5 zero calibration switch			4
001E <sub>H</sub>	40031	Word	CH1 calibration range switch	0,1  (0: Calibrate indicated range only, 1: Calibrate both ranges at same time)	About calibration range	2/4
001F <sub>H</sub>	40032	Word	CH2 calibration range switch			2/4
0020 <sub>H</sub>	40033	Word	CH3 calibration range switch			2/4
0021 <sub>H</sub>	40034	Word	CH4 calibration range switch			2/4
0022 <sub>H</sub>	40035	Word	CH5 calibration range switch			4
0023 <sub>H</sub>	40036	Word	CH1 range-1 high alarm setting	0 to 9999  Decimal point position depends on range	Alarm setting	2/4
0024 <sub>H</sub>	40037	Word	CH1 range-1 low alarm setting			2/4
0025 <sub>H</sub>	40038	Word	CH1 range-2 high alarm setting			2/4
0026 <sub>H</sub>	40039	Word	CH1 range-2 low alarm setting			2/4
0027 <sub>H</sub>	40040	Word	CH2 range-1 high alarm setting			2/4
0028 <sub>H</sub>	40041	Word	CH2 range-1 low alarm setting			2/4
0029 <sub>H</sub>	40042	Word	CH2 range-2 high alarm setting			2/4
002A <sub>H</sub>	40043	Word	CH2 range-2 low alarm setting			2/4
002B <sub>H</sub>	40044	Word	CH3 range-1 high alarm setting			2/4
002C <sub>H</sub>	40045	Word	CH3 range-1 low alarm setting			2/4
002D <sub>H</sub>	40046	Word	CH3 range-2 high alarm setting			2/4
002E <sub>H</sub>	40047	Word	CH3 range-2 low alarm setting			2/4
002F <sub>H</sub>	40048	Word	CH4 range-1 high alarm setting			2/4
0030 <sub>H</sub>	40049	Word	CH4 range-1 low alarm setting			2/4
0031 <sub>H</sub>	40050	Word	CH4 range-2 high alarm setting			2/4
0032 <sub>H</sub>	40051	Word	CH4 range-2 low alarm setting			2/4
0033 <sub>H</sub>	40052	Word	CH5 range-1 high alarm setting			4
0034 <sub>H</sub>	40053	Word	CH5 range-1 low alarm setting			4
0035 <sub>H</sub>	40054	Word	CH5 range-2 high alarm setting			4
0036 <sub>H</sub>	40055	Word	CH5 range-2 low alarm setting	4		

**Word data [read-out/write-in]: Function code [03<sub>H</sub>, 06<sub>H</sub>, 10<sub>H</sub>]**

**User settings**

Relative address	Register No.	Data type	Memory contents	Read-out/write-in data	Remarks or corresponding parameter	Relevant model
0037 <sub>H</sub>	40056	Word	CH1 alarm mode	0,1,2 (0: High limit alarm, 1: Low limit alarm, 2: High or low limit)	Alarm setting	2/4
0038 <sub>H</sub>	40057	Word	CH2 alarm mode			2/4
0039 <sub>H</sub>	40058	Word	CH3 alarm mode			2/4
003A <sub>H</sub>	40059	Word	CH4 alarm mode			2/4
003B <sub>H</sub>	40060	Word	CH5 alarm mode			4
003C <sub>H</sub>	40061	Word	CH1 alarm switch	0,1 (0: Alarm OFF, 1: Alarm ON)		2/4
003D <sub>H</sub>	40062	Word	CH2 alarm switch			2/4
003E <sub>H</sub>	40063	Word	CH3 alarm switch			2/4
003F <sub>H</sub>	40064	Word	CH4 alarm switch			2/4
0040 <sub>H</sub>	40065	Word	CH5 alarm switch			4
0041 <sub>H</sub>	40066	Word	Alarm hysteresis	0000H to 0014H (0 to 20%FS)		2/4
0042 <sub>H</sub>	40067	Word	Auto calibration start time(day)	00H to 06H (Sun. to Sat.)	Setting of auto calibration	2/4
0043 <sub>H</sub>	40068	Word	Auto calibration start time(hour)	00H to 23H (BCD code)		2/4
0044 <sub>H</sub>	40069	Word	Auto calibration start time(min)	00H to 59H (BCD code)		2/4
0045 <sub>H</sub>	40070	Word	Auto calibration cycle			2/4
0046 <sub>H</sub>	40071	Word	Auto calibration cycle unit	0,1 (0: h, 1: days)		2/4
0047 <sub>H</sub>	40072	Word	Auto calibration switch	0,1 (0: OFF, 1: ON)		2/4
0048 <sub>H</sub>	40073	Word	Auto calibration gas flow time	003CH to 0257H (60 to 599 sec)		2/4
0049 <sub>H</sub>	40074	Word	Key lock switch	0,1 (0: OFF, 1: ON)	Key lock	2/4
004A <sub>H</sub>	40075	Word	Remote range switch	0,1 (0: OFF, 1: ON)	Remote range	2/4
004B <sub>H</sub>	40076	Word	Response time 1	0000H to 0063H (0 to 99 sec) *(a)	Response time	2/4
004C <sub>H</sub>	40077	Word	Response time 2			2/4
004D <sub>H</sub>	40078	Word	Response time 3			2/4
004E <sub>H</sub>	40079	Word	Response time 4			4
004F <sub>H</sub>	40080	Word	Response time 5			4
0050 <sub>H</sub>	40081	Word	Response time 6			4
0051 <sub>H</sub>	40082	Word	Response time 7			4
0052 <sub>H</sub>	40083	Word	Response time 8			4
0053 <sub>H</sub>	40084	Word	Oxygen meter response time			2/4
0054 <sub>H</sub>	40085	Word	1st order moving average period	0000H to 003bH (0 to 59 min or 1 to 4 h)	Average period	2/4
0055 <sub>H</sub>	40086	Word	2nd order moving average period			2/4
0056 <sub>H</sub>	40087	Word	3rd order moving average period			2/4
0057 <sub>H</sub>	40088	Word	4th order moving average period			4
0058 <sub>H</sub>	40089	Word	1st order moving average period unit	0,1 (0: h, 1: min)		2/4
0059 <sub>H</sub>	40090	Word	2nd order moving average period unit			2/4
005A <sub>H</sub>	40091	Word	3rd order moving average period unit			2/4
005B <sub>H</sub>	40092	Word	4th order moving average period unit			4

**Word data [read-out/write-in]: Function code [03<sub>H</sub>, 06<sub>H</sub>, 10<sub>H</sub>]**

### User settings

Relative address	Register No.	Data type	Memory contents	Read-out/write-in data	Remarks or corresponding parameter	Relevant model
005C <sub>H</sub>	40093	Word	Hold switch	0,1 (0: OFF, 1: ON)	Output hold	2/4
005D <sub>H</sub>	40094	Word	Oxygen conversion reference value	01H to 13H(1% to 19%)	Oxygen conversion reference value	2/4
005E <sub>H</sub>	40095	Word	Peak alarm switch	0,1 (0: OFF, 1: ON)	Setting of peak alarm	
005F <sub>H</sub>	40096	Word	Peak alarm concentration	0064H to 03e8H (100 to 1000ppm)		
0060 <sub>H</sub>	40097	Word	Peak alarm count	0001H to 0063H (1 to 99 times)		2/4
0061 <sub>H</sub>	40098	Word	Peak alarm hysteresis	0000H to 0014H (0 to 20%FS)		2/4
0062 <sub>H</sub>	40099	Word	Auto zero calibration start (day)	00H to 06H (Sun. to Sat.)	Setting of auto zero calibration	2/4
0063 <sub>H</sub>	40100	Word	Auto zero calibration start (hour)	00H to 23H (BCD code)		2/4
0064 <sub>H</sub>	40101	Word	Auto zero calibration start (min)	00H to 59H (BCD code)		2/4
0065 <sub>H</sub>	40102	Word	Auto zero calibration cycle			2/4
0066 <sub>H</sub>	40103	Word	Auto zero calibration cycle unit	0,1 (0: h, 1: days)		2/4
0067 <sub>H</sub>	40104	Word	Auto zero calibration switch	0,1 (0: OFF, 1: ON )		2/4
0068 <sub>H</sub>	40105	Word	Auto zero calibration gas flow time	003CH to 0257H (60 to 599 sec)		2/4
0069 <sub>H</sub>	40106	Word	CH1 range change setting	0,1 (0: range-1, 1: range-2.)	Range changeover (disabled if remote range ON)	2/4
006A <sub>H</sub>	40107	Word	CH2 range change setting			2/4
006B <sub>H</sub>	40108	Word	CH3 range change setting			2/4
006C <sub>H</sub>	40109	Word	CH4 range change setting			2/4
006D <sub>H</sub>	40110	Word	CH5 range change setting			4

### Word data [write-in] : Function code [06<sub>H</sub>]

#### Operation command

Relative address	Register No.	Data type	Memory contents	Write-in data	Remarks or corresponding parameter	Relevant model
07D0 <sub>H</sub>	42001	Word	Keying command	01H:MODE 02H: Side, 04H: Up, 08H: Down 10H: ESC, 20H: ENT 40H: ZERO, 80H: SPAN	Sending a value simulates keying	2/4
07D1 <sub>H</sub>	42002	Word	Display change	1: Return to measurement mode display	Force to return to measurement mode	2/4



**Word data [read-out only] : Function code[04<sub>H</sub>]**

**Measurement value and status**

Relative address	Register No.	Data type	Memory contents	Read-out data	Remarks or corresponding parameter	Relevant model
0000 <sub>H</sub>	30001	Word	CH1 concentration	Concentration: -9999 to 9999 (value corresponding to indication without decimal point) Decimal point position: 0,1,2,3 (0; concentration/1 1; concentration/10 2; concentration/100 3; concentration/1000) Measurement unit: 0, 1, 2, 3 (0; vol% 1; ppm 2; mg/m <sup>3</sup> 3; g/m <sup>3</sup> )  Transmit values under current measurement conditions		2/4
0001 <sub>H</sub>	30002	Word	CH1 decimal point position			2/4
0002 <sub>H</sub>	30003	Word	CH1 measurement unit			2/4
0003 <sub>H</sub>	30004	Word	CH2 concentration			2/4
0004 <sub>H</sub>	30005	Word	CH2 decimal point position			2/4
0005 <sub>H</sub>	30006	Word	CH2 measurement unit			2/4
0006 <sub>H</sub>	30007	Word	CH3 concentration			2/4
0007 <sub>H</sub>	30008	Word	CH3 decimal point position			2/4
0008 <sub>H</sub>	30009	Word	CH3 measurement unit			2/4
0009 <sub>H</sub>	30010	Word	CH4 concentration			2/4
000A <sub>H</sub>	30011	Word	CH4 decimal point position			2/4
000B <sub>H</sub>	30012	Word	CH4 measurement unit			2/4
000C <sub>H</sub>	30013	Word	CH5 concentration			2/4
000D <sub>H</sub>	30014	Word	CH5 decimal point position			2/4
000E <sub>H</sub>	30015	Word	CH5 measurement unit			2/4
000F <sub>H</sub>	30016	Word	CH6 concentration			2/4
0010 <sub>H</sub>	30017	Word	CH6 decimal point position			2/4
0011 <sub>H</sub>	30018	Word	CH6 measurement unit			2/4
0012 <sub>H</sub>	30019	Word	CH7 concentration			2/4
0013 <sub>H</sub>	30020	Word	CH7 decimal point position			2/4
0014 <sub>H</sub>	30021	Word	CH7 measurement unit			2/4
0015 <sub>H</sub>	30022	Word	CH8 concentration			2/4
0016 <sub>H</sub>	30023	Word	CH8 decimal point position			2/4
0017 <sub>H</sub>	30024	Word	CH8 measurement unit			2/4
0018 <sub>H</sub>	30025	Word	CH9 concentration			4
0019 <sub>H</sub>	30026	Word	CH9 decimal point position			4
001A <sub>H</sub>	30027	Word	CH9 measurement unit			4
001B <sub>H</sub>	30028	Word	CH10 concentration			4
001C <sub>H</sub>	30029	Word	CH10 decimal point position			4
001D <sub>H</sub>	30030	Word	CH10 measurement unit			4
001E <sub>H</sub>	30031	Word	CH11 concentration			4
001F <sub>H</sub>	30032	Word	CH11 decimal point position			4
0020 <sub>H</sub>	30033	Word	CH11 measurement unit			4
0021 <sub>H</sub>	30034	Word	CH12 concentration	4		
0022 <sub>H</sub>	30035	Word	CH12 decimal point position	4		
0023 <sub>H</sub>	30036	Word	CH12 measurement unit	4		

**Word data [read-out only] : Function code[04<sub>H</sub>]**

**Measurement value and status**

Relative address	Register No.	Data type	Memory contents	Read-out data	Remarks or corresponding parameter	Relevant model		
0024 <sub>H</sub>	30037	Word	Peak count	0 to 100 times/hour		2/4		
0025 <sub>H</sub>	30038	Word	CH1 current range	0, 1 (0; range-1, 1;range-2)		2/4		
0026 <sub>H</sub>	30039	Word	CH2 current range			2/4		
0027 <sub>H</sub>	30040	Word	CH3 current range			2/4		
0028 <sub>H</sub>	30041	Word	CH4 current range			2/4		
0029 <sub>H</sub>	30042	Word	CH5 current range			4		
002A <sub>H</sub>	30043	Word	CH1 high/low limit alarm	0, 1, 2 (0: No alarm, 1: High limit alarm, 2: Low limit alarm	Whether or how alarm is currently produced.	2/4		
002B <sub>H</sub>	30044	Word	CH2 high/low limit alarm			2/4		
002C <sub>H</sub>	30045	Word	CH3 high/low limit alarm			2/4		
002D <sub>H</sub>	30046	Word	CH4 high/low limit alarm			2/4		
002E <sub>H</sub>	30047	Word	CH5 high/low limit alarm			4		
002F <sub>H</sub>	30048	Word	Peak count alarm	0,1 (0: No, 1: Yes)		2/4		
0030 <sub>H</sub>	30049	Word	Auto (Auto zero) calibration in progress	0,1 (0: No, 1: Yes)		2/4		
0031 <sub>H</sub>	30050	Word	CH1 zero calibration in progress	0,1 (0: No, 1: Yes)		2/4		
0032 <sub>H</sub>	30051	Word	CH2 zero calibration in progress			2/4		
0033 <sub>H</sub>	30052	Word	CH3 zero calibration in progress			2/4		
0034 <sub>H</sub>	30053	Word	CH4 zero calibration in progress			2/4		
0035 <sub>H</sub>	30054	Word	CH5 zero calibration in progress			4		
0036 <sub>H</sub>	30055	Word	CH1 span calibration in progress			2/4		
0037 <sub>H</sub>	30056	Word	CH2 span calibration in progress			2/4		
0038 <sub>H</sub>	30057	Word	CH3 span calibration in progress			2/4		
0039 <sub>H</sub>	30058	Word	CH4 span calibration in progress			2/4		
003A <sub>H</sub>	30059	Word	CH5 span calibration in progress			4		
003B <sub>H</sub>	30060	Word	Instrument error			0,1 (0: No, 1; Yes)	Whether error is produced	2/4
003C <sub>H</sub>	30061	Word	Calibration error			0,1 (0: No, 1; Yes)	Whether error is produced	2/4
003D <sub>H</sub>	30062	Word	Latest error No.			-1 to 9 (Error No.-1) * (b) 0 to 6 (Sun. to Sat.) 0 to 23 (hours) 0 to 59 (min) 0 to 4	Error log contents	2/4
003E <sub>H</sub>	30063	Word	Latest error WEEK	2/4				
003F <sub>H</sub>	30064	Word	Latest error HOUR	2/4				
0040 <sub>H</sub>	30065	Word	Latest error MIN	2/4				
0041 <sub>H</sub>	30066	Word	Latest error TARGET	2/4				

**Word data [read-out only] : Function code[04<sub>H</sub>]**

**Measurement value and status**

Relative address	Register No.	Data type	Memory contents	Read-out data	Remarks or corresponding parameter	Relevant model
0042 <sub>H</sub>	30067	Word	The previous error No.	-1 to 9 (Error No.-1)		2/4
0043 <sub>H</sub>	30068	Word	The previous error WEEK	0 to 6 (Sun. to Sat.)		2/4
0044 <sub>H</sub>	30069	Word	The previous error HOUR	0 to 23 (hours)		2/4
0045 <sub>H</sub>	30070	Word	The previous error MIN	0 to 59 (min)		2/4
0046 <sub>H</sub>	30071	Word	The previous error TARGET	0 to 4		2/4
						2/4
						2/4
007E <sub>H</sub>	30127	Word	Oldest error No.	-1 to 9 (Error No.-1)		2/4
007F <sub>H</sub>	30128	Word	Oldest error WEEK	0 to 6 (Sun. to Sat.)		2/4
0080 <sub>H</sub>	30129	Word	Oldest error HOUR	0 to 23 (hour)		2/4
0081 <sub>H</sub>	30130	Word	Oldest error MIN	0 to 59 (min)	2/4	
0082 <sub>H</sub>	30131	Word	Oldest error TARGET	0 to 4	2/4	
0083 <sub>H</sub>	30132	Word	Error 1	0,1 (0: No, 1: Yes)	Whether error is currently produced	2/4
0084 <sub>H</sub>	30133	Word	Error 2			2
0085 <sub>H</sub>	30134	Word	Error 3			2
0086 <sub>H</sub>	30135	Word	Error 10			2/4
0087 <sub>H</sub>	30136	Word	CH1 Error 4	0,1 (0: No, 1: Yes)		2/4
0088 <sub>H</sub>	30137	Word	CH1 Error 5			2/4
0089 <sub>H</sub>	30138	Word	CH1 Error 6			2/4
008A <sub>H</sub>	30139	Word	CH1 Error 7			2/4
008B <sub>H</sub>	30140	Word	CH1 Error 8			2/4
008C <sub>H</sub>	30141	Word	CH1 Error 9			2/4
					2/4	
					2/4	
0099 <sub>H</sub>	30154	Word	CH4 Error 4	0,1 (0: No, 1: Yes)		2/4
009A <sub>H</sub>	30155	Word	CH4 Error 5			2/4
009B <sub>H</sub>	30156	Word	CH4 Error 6			2/4
009C <sub>H</sub>	30157	Word	CH4 Error 7			2/4
009D <sub>H</sub>	30158	Word	CH4 Error 8			2/4
009E <sub>H</sub>	30159	Word	CH4 Error 9			2/4
009F <sub>H</sub>	30160	Word	CH5 Error 4	0,1 (0: No, 1: Yes)		4
00A0 <sub>H</sub>	30161	Word	CH5 Error 5			4
00A1 <sub>H</sub>	30162	Word	CH5 Error 6			4
00A2 <sub>H</sub>	30163	Word	CH5 Error 7			4
00A3 <sub>H</sub>	30164	Word	CH5 Error 8			4
00A4 <sub>H</sub>	30165	Word	CH5 Error 9			4

**Word data [read-out only] : Function code[04<sub>H</sub>]**

**Measurement value and status**

Relative address	Register No.	Data type	Memory contents	Read-out data	Remarks or corresponding parameter	Relevant model
00A5 <sub>H</sub>	30166	Word	CH1 auto zero calibration in progress	0,1 (0: No, 1: Yes)		2/4
00A6 <sub>H</sub>	30167	Word	CH1 auto span calibration in progress			2/4
00A7 <sub>H</sub>	30168	Word	CH1 hold in progress	0,1 (0: No, 1: Yes)		2/4
						2/4
						2/4
00AE <sub>H</sub>	30175	Word	CH4 auto zero calibration in progress	0,1 (0: No, 1: Yes)		2/4
00AF <sub>H</sub>	30176	Word	CH4 auto span calibration in progress			2/4
00B0 <sub>H</sub>	30177	Word	CH4 hold in progress	0,1 (0: No, 1: Yes)		2/4
00B1 <sub>H</sub>	30178	Word	CH5 auto zero calibration in progress	0,1 (0: No, 1: Yes)		4
00B2 <sub>H</sub>	30179	Word	CH5 auto span calibration in progress			4
00B3 <sub>H</sub>	30180	Word	CH5 hold in progress	0,1 (0: No, 1: Yes)		4
00B4 <sub>H</sub>	30181	Word	Display information (1)	* (c)		2/4
00B5 <sub>H</sub>	30182	Word	Display information (2)			2/4
00B6 <sub>H</sub>	30183	Word	Display information (3)			2/4
00B7 <sub>H</sub>	30184		(Do not use)			
00B8 <sub>H</sub>	30185		(Do not use)			
00B9 <sub>H</sub>	30186		(Do not use)			
00BA <sub>H</sub>	30187		(Do not use)			
00BB <sub>H</sub>	30188		(Do not use)			
00BC <sub>H</sub>	30189	Word	Manual calibration channel	Cursor CH-1 * (d)		2/4
00BD <sub>H</sub>	30190		(Do not use)			

**Word data [read-out only] : Fuction code[04<sub>H</sub>]**

**Fixed setting**

Relative address	Register No.	Data type	Memory contents	Read-out data	Remarks or corresponding parameter	Relevant model
0425 <sub>H</sub>	31062	Word	CH1 range numbers	1, 2		2/4
0426 <sub>H</sub>	31063	Word	CH2 range numbers	(1: 1 range, 2: 2 ranges)		2/4
0427 <sub>H</sub>	31064	Word	CH3 range numbers			2/4
0428 <sub>H</sub>	31065	Word	CH4 range numbers			2/4
0429 <sub>H</sub>	31066	Word	CH5 range numbers			4
042A <sub>H</sub>	31067	Word	CH1 range-1 unit		0,1,2,3	
042B <sub>H</sub>	31068	Word	CH1 range-2 unit	(0;vol%		2/4
042C <sub>H</sub>	31069	Word	CH2 range-1 unit	1; ppm		2/4
042D <sub>H</sub>	31070	Word	CH2 range-2 unit	2; mg/m <sup>3</sup>		2/4
042E <sub>H</sub>	31071	Word	CH3 range-1 unit	3; g/m <sup>3</sup> )		2/4
042F <sub>H</sub>	31072	Word	CH3 range-2unit			2/4
0430 <sub>H</sub>	31073	Word	CH4 range-1 unit			2/4
0431 <sub>H</sub>	31074	Word	CH4 range-2 unit			2/4
0432 <sub>H</sub>	31075	Word	CH5 range-1 unit			4
0433 <sub>H</sub>	31076	Word	CH5 range-2 unit			4
0434 <sub>H</sub>	31077	Word	CH1 range-1 value	1 to 9999		2/4
0435 <sub>H</sub>	31078	Word	CH1 range-2 value			2/4
0436 <sub>H</sub>	31079	Word	CH2 range-1 value			2/4
0437 <sub>H</sub>	31080	Word	CH2 range-2 value			2/4
0438 <sub>H</sub>	31081	Word	CH3 range-1 value			2/4
0439 <sub>H</sub>	31082	Word	CH3 range-2 value			2/4
043A <sub>H</sub>	31083	Word	CH4 range-1 value			2/4
043B <sub>H</sub>	31084	Word	CH4 range-2 value			2/4
043C <sub>H</sub>	31085	Word	CH5 range-1 value			4
043D <sub>H</sub>	31086	Word	CH5 range-2 value			4
043E <sub>H</sub>	31087	Word	CH1 range-1 decimal point position	0,1,2,3		2/4
043F <sub>H</sub>	31088	Word	CH1 range-2 decimal point position	(0: Nothing below decimal point, 1: 1 digit below decimal point, 2: 2 digits below decimal point, 3: 3 digits below decimal point.		2/4
0440 <sub>H</sub>	31089	Word	CH2 range-1 decimal point position			2/4
0441 <sub>H</sub>	31090	Word	CH2 range-2 decimal point position			2/4
0442 <sub>H</sub>	31091	Word	CH3 range-1 decimal point position			2/4
0443 <sub>H</sub>	31092	Word	CH3 range-2 decimal point position			2/4
0444 <sub>H</sub>	31093	Word	CH4 range-1 decimal point position			2/4
0445 <sub>H</sub>	31094	Word	CH4 range-2 decimal point position			2/4
0446 <sub>H</sub>	31095	Word	CH5 range-1 decimal point position			4
0447 <sub>H</sub>	31096	Word	CH5 range-2 decimal point position			4

Notes

1. Relevant model: 2; Model IR200, 4; Model IR400  
For data for which only 4 or 2 is indicated, there is no data for the other model.
2. For contents of \*(a) to \*(d), refer to Section 7.3 "Supplements to address map".

## 7.3 Supplement to address map

\* (a) Register No. 40076 to 40083 (response time 1 to 8)

The following shows signals corresponding to response time 1 to 8.

- Model IR200

Response time 1	1st component detector signal
Response time 2	2nd component detector signal
Response time 3	3rd component detector signal
Response time 4 to 8	Unused

The above does not include sensor signals of oxygen.

- Model IR400

Response time 1	1st component measurement detector signal
Response time 2	1st component interference compensation detector signal
Response time 3	2nd component measurement detector signal
Response time 4	2nd component interference compensation detector signal
Response time 5	3rd component measurement detector signal
Response time 6	3rd component interference compensation detector signal
Response time 7	4th component measurement detector signal
Response time 8	4th component interference compensation detector signal

The above does not include sensor signals of oxygen.

\* (b) Register No. 30062 to 30131 (error log)

Up to 14 errors logged can be read in the order from the latest to older ones.

The contents are as follows.

Error No.: No. of produced error. Stored value is error number minus 1.

Error WEEK: Day when error occurred.

Error HOUR: Indicates at what o'clock error occurred.

Error MIN: Indicates at what minutes error occurred.

Error TARGET: No. of CH where error occurred.

CH No. minus 1 is stored.

0 at error No. 1, 2, 3 or 10.

No. of optical system where error occurred minus 1 if error No. is 1 in case of model IR400.

---

\* (c) Register numbers 30181, 30182, 30183 (display information (1), (2), (3))  
The display information is values for knowing the current display status of the instrument.

- Contents of values of display information (1) (status of each setting panel)

- 0: Measurement mode display (manual calibration display included)

- 1: Menu mode display

- 2: Changeover of range display

- 3: Calibration setting display

- 4: Alarm setting display

- 5: Automatic calibration setting display

- 6: Peak alarm setting display

- 7: Parameter setting display

- 8: Maintenance mode display

- 9: Factory mode display

- 10: Auto zero calibration setting display

- Contents of values of display information (2) (status at manual calibration)

- 0: Measurement mode display

- 4: Channel selection display at manual zero calibration

- 5: Zero calibration wait display at manual zero calibration

- 6: Zero calibration in progress display at manual zero calibration

- 7: Channel selection display at manual span calibration

- 8: Span calibration wait display at manual span calibration

- 9: Span calibration in progress display at manual span calibration

- 10: Error contents indication display

- Contents of values of display information (3)

- Correspond to value of CH (channel) from which the measurement mode is displayed.

- Top channel number minus 1 is stored.

\* (d) Register number 30189 (manual calibration channel)

Data for knowing a channel (component) which the cursor is positioned at to carry out a calibration at when a manual calibration is under way.

Channel number to carry out a calibration at minus 1 is stored.

## 8. SAMPLE PROGRAM

---

This chapter concerns data read-out/write-in sample program which operates on N88-Japanese BASIC (\*2) for PC-9801 (\*1) or compatible PCs.

Note that the program shown here is for reference for you to create a program and not for guaranteeing all actions.

Before executing the program, make sure of the communication conditions in the following procedure.

- Communication speed (baud rate):

Match the conditions with this instrument using SWITCH command and SPEED command of MS-DOS (\*3).

For SWITCH command and SPEED command, refer to the reference manual of MS-DOS.

- Data length, stop bits and parity:

Set in this program. Match the conditions with this instrument.

\*1 PC-9801 series are products of NEC Corporation.

\*2 N88-Japanese BASIC is a registered trade mark of NEC Corporation.

\*3 MS-DOS is a registered trade mark of Microsoft Corporation.



---

(a) **Example of data read-out**

Operation: Read-out CH1 measurement concentration value.

(Continuous word read-out from read-out only area)

Used function code : 04H

Read-out start register No. : 30001

Read-out word number : 3

```
1000 '-----
1010 '  READ CONTINUOUS WORDS      SAMPLE PROGRAM
1020 '-----
1030 '
1040 ' Transmission speed = 9600 bps (selected with SPEED command and SWITCH command of MS-DOS)
1050 '
1060 CLS
1070 DIM CC(255)
1080 '
1100 '----- Send data setting -----
1110 CC(1)=&H01      'Station No.      = 1
1120 CC(2)=&H04      'Function code = 04H
1130 CC(3)=&H00      'Upper byte of relative address(0000H) of resister No.30001
1140 CC(4)=&H00      'Lower byte of relative address(0000H) of resister No.30001
1150 CC(5)=&H00      'Upper byte of read-out word data(0003H)
1160 CC(6)=&H03      'Lower byte of read-out word data(0003H)
1170 COUNT=6
1200 '
1210 '----- CRC code calculation of send data -----
1220 GOSUB *CRC.CALC
1230 CC(7)=CRC.L      'Lower byte of CRC calculation result → Upper byte in message
1240 CC(8)=CRC.H      'Upper byte of CRC calculation result → Lower byte in message
1250 COUNT=COUNT+2
1300 '
1310 '----- Send data -----
1320 PRINT " Sending data > ";
1330 OPEN "COM1:N81NN" AS #1      ' No parity ... "N81NN"
1340
1350
1360 FOR I=1 TO COUNT
1370   PRINT #1,CHR$(CC(I));      'Writing in transmission port
1380   PRINT RIGHT$("0"+HEX$(CC(I)),2);" "; 'Displaying on screen
1390 NEXT I
1400 '
1410 FOR I=0 TO 12000 :NEXT I      ' Interval time
1500 '

```

```

1510 '----- Data receive -----
1520 PRINT
1530 LENGTH=LOC(1) 'Number of data in receiving buffer
1540 IF LENGTH=0 THEN PRINT "No answer" :END
1550 PRINT " Receiving data < ";
1560 FOR I=1 TO LENGTH
1570 X$=INPUT$(1,#1) 'Taking data from receiving buffer
1580 CC(I)=ASC(X$) 'Digitizing and storing
1590 PRINT RIGHT$("0"+HEX$(CC(I)),2);" "; 'Displaying on screen
1600 NEXT I
1610 CLOSE #1
1620 COUNT=LENGTH-2
1630 GOSUB *CRC.CALC
1700 '
1710 '----- Transmission error check -----
1720 PRINT
1730 CRC.L$=RIGHT$("0"+HEX$(CRC.L),2)
1740 CRC.H$=RIGHT$("0"+HEX$(CRC.H),2)
1750 PRINT "CRC calculation = ";CRC.L$;" ";CRC.H$
1760 IF CC(LENGTH-1)<>CRC.L THEN GOTO *ER.MESSAGE
1770 IF CC(LENGTH)<>CRC.H THEN GOTO *ER.MESSAGE
1780 GOTO *PRT.RESULT
1790 *ER.MESSAGE
1800 PRINT "Communication error"
1810 END
1900 '
1910 '----- Display of result -----
1920 *PRT.RESULT
1930
1940 PRINT
1950 VALUE=HEX$(CC(4))+RIGHT$("0"+HEX$(CC(5)),2) '2byte 1word
1960 DE$=HEX$(CC(6))+RIGHT$("0"+HEX$(CC(7)),2) '2byte 1word
1970 UN$=HEX$(CC(8))+RIGHT$("0"+HEX$(CC(9)),2) '2byte 1word
1980
1990 Select Case Val("&H"+DE$)
2000 Case 0
2010 CONC=Val("&H"+Value$)/1
2020 Case 1
2030 CONC=Val("&H"+Value$)/10
2040 Case 2
2050 CONC=Val("&H"+Value$)/100
2060 Case 3
2070 CONC=Val("&H"+Value$)/1000
2080 End Select
2090
2100 Select Case Val("&H"+UN$)
2110 Case 0
2120 UNIT="vol%"
2130 Case 1
2140 UNIT="ppm%"

```

---

```

2150         Case 2
2160             UNIT="mg/m3"
2170         Case 3
2180             UNIT="g/m3"
2190 End Select
2200
2210 Print "CH1 measurement concentration =";CONC;UNIT
2220
2230 END
3000 '
3010 '----- CRC calculation -----
3020 *CRC.CALC           ' For contents, refer to CRC calculation flow chart
3030 CR=&HFFFF
3040 FOR I=1 TO COUNT
3050     CR=CR XOR CC(I)
3060     FOR J=1 TO 8
3070         CT=CR AND &H1
3080         IF CR<0 THEN CH=1 ELSE CH=0:GOTO *CRC.CALC.10
3090         CR=CR AND &H7FFF
3100     *CRC.CALC.10
3110         CR=INT(CR/2)
3120         IF CH=1 THEN CR=CR OR &H4000
3130         IF CT=1 THEN CR=CR XOR &HA001
3140     NEXT J
3150 NEXT I
3160 CRC.L=CR AND &HFF           ' Lower byte of CRC calculation
3170 CRC.H=((CR AND &HFF00)/256 AND &HFF) ' Upper byte of CRC calculation
3180 RETURN

```

---

**(b) Data write-in example**

Operation : Change CH1 measurement range via communication

(Single word write-in)

Used function code : 06H

Write-in register No. : 40106

Write-in data : 1 (changeover from range 1 to range 2)

```
1000 '-----
1010 '   WRITE 1 WORD       SAMPLE PROGRAM
1020 '-----
1030 '
1040 ' Transmission speed = 9600 bps (selected with SPEED command and SWITCH command of MS-DOS)
1050 '
1060 CLS
1070 DIM CC(255)
1080 '
1100 '----- Send data setting -----
1110 CC(1)=&H01           ' Station No.       = 1
1120 CC(2)=&H06           ' Function code = 06H
1130 CC(3)=&H00           ' Upper byte of relative address(0069H) of resister No.40106
1140 CC(4)=&H69           ' Lower byte of relative address(0069H) of resister No.40106
1150 CC(5)=&H00           ' Upper byte of Write-in word data(0001H)
1160 CC(6)=&H01           ' Lower byte of Write-in word data(0001H)
1170 COUNT=6
1200 '
1210 '----- CRC code calculation of send data -----
1220 GOSUB *CRC.CALC
1230 CC(7)=CRC.L          ' Lower byte of CRC calculation result → Upper byte in message
1240 CC(8)=CRC.H          ' Upper byte of CRC calculation result → Lower byte in message
1250 COUNT=COUNT+2
1300 '
1310 '----- Send data -----
1320 PRINT "Sending data > ";
1330 OPEN "COM1:N81NN" AS #1           ' No parity ... "N81NN "
1340
1350
1360 FOR I=1 TO COUNT
1370   PRINT #1,CHR$(CC(I));           ' Writing transmission port
1380   PRINT RIGHT$("0"+HEX$(CC(I)),2);" "; ' Displaying on screen
1390 NEXT I
1400 '
1410 FOR I=0 TO 12000 :NEXT I         ' Interval time
1500 '

```

```

1510 '----- Data receive -----
1520 PRINT
1530 LENGTH=LOC(1) 'Number of data in receiving buffer
1540 IF LENGTH=0 THEN PRINT "No answer" :END
1550 PRINT "Receiving data < ";
1560 FOR I=1 TO LENGTH
1570 X$=INPUT$(1,#1) 'Taking data from receiving buffer
1580 CC(I)=ASC(X$) 'Digitizing and storing
1590 PRINT RIGHT$("0"+HEX$(CC(I)),2);" "; 'Displaying on screen
1600 NEXT I
1610 CLOSE #1
1620 COUNT=LENGTH-2
1630 GOSUB *CRC.CALC
1700 '
1710 '----- Transmission error check -----
1720 PRINT
1730 CRC.L$=RIGHT$("0"+HEX$(CRC.L),2)
1740 CRC.H$=RIGHT$("0"+HEX$(CRC.H),2)
1750 PRINT "CRC calculation = ";CRC.L$;" ";CRC.H$
1760 IF CC(LENGTH-1)<>CRC.L THEN GOTO *ER.MESSAGE
1770 IF CC(LENGTH)<>CRC.H THEN GOTO *ER.MESSAGE
1780 GOTO *PRT.RESULT
1790 *ER.MESSAGE
1800 PRINT "Communication error"
1810 END
1900 '
1910 '----- Display of result -----
1920 *PRT.RESULT
1930 PRINT
1940 PRINT " Range change ended "
1950 END
3000 '
3010 '----- CRC calculation -----
3020 *CRC.CALC 'For contents, refer to CRC calculation flow
3030 CR=&HFFFF
3040 FOR I=1 TO COUNT
3050 CR=CR XOR CC(I)
3060 FOR J=1 TO 8
3070 CT=CR AND &H1
3080 IF CR<0 THEN CH=1 ELSE CH=0:GOTO *CRC.CALC.10
3090 CR=CR AND &H7FFF
3100 *CRC.CALC.10
3110 CR=INT(CR/2)
3120 IF CH=1 THEN CR=CR OR &H4000
3130 IF CT=1 THEN CR=CR XOR &HA001
3140 NEXT J
3150 NEXT I
3160 CRC.L=CR AND &HFF 'Lower byte of CRC calculation
3170 CRC.H=((CR AND &HFF00)/256 AND &HFF) 'Upper byte of CRC calculation
3180 RETURN

```

## 9. TROUBLESHOOTING

---

If the communication is unavailable, check the following items.

Whether all devices related to communication are turned on.

Whether connections are correct.

Whether the number of connected instruments and connection distance are as specified

Whether communication conditions coincide between the master station (host computer) and slave stations (instrument)

Transmission speed : 9600bps

Data length : 8 bits

Stop bit : 1 bit

Parity : None

Whether send/receive signal timing conforms to Section 5.6 in this manual.

Whether the station No. designated as send destination by the master station coincides with the station No. of the connected instrument.

Whether more than one instrument connected on the same transmission line shares the same station No.

Whether the station No. of instruments is set at other than 0.

If it's 0, the communication function does not work.







# Revision Record

---

Manual Title : IR200/IR400 Infrared Gas Analyzer Communication Functions (MODBUS)

Manual Number : IM 11G02P01-01E

---

<b>Edition</b>	<b>Date</b>	<b>Remark (s)</b>
1st	Sept. 2002	Newly published

---