

Allowable load resistance:

Output-1 Range	Allowable Load Resistance	Output-1 Range	Allowable Load Resistance
4 to 20 mA DC	750 Ω maximum	0 to 10 mV DC	250 k Ω minimum
2 to 10 mA DC	1500 Ω maximum	0 to 100 mV DC	250 k Ω minimum
1 to 5 mA DC	3000 Ω maximum	0 to 1 V DC	2 k Ω minimum
0 to 20 mA DC	750 Ω maximum	0 to 10 V DC	10 k Ω minimum
0 to 16 mA DC	900 Ω maximum	0 to 5 V DC	2 k Ω minimum
0 to 10 mA DC	1500 Ω maximum	1 to 5 V DC	2 k Ω minimum
0 to 1 mA DC	15 k Ω maximum	-10 to +10 V DC	10 k Ω minimum
Output-2 Range	Allowable Load Resistance	Output-2 Range	Allowable Load Resistance
4 to 20 mA DC	350 Ω maximum	1 to 5 V DC	2 k Ω minimum

Note: Use HART communication within the allowable load resistance range of the HART communication specifications.

Output resistance: Current output; 500 k Ω or more

Voltage output other than below: 1 Ω or less

0 to 10 mV DC, 0 to 100 mV DC: 100 Ω or less

Zero adjustment: -5 to +5%

Span adjustment: 95 to 105%

■ HART Communication Specifications

Frequency band: 500 Hz to 10 kHz (-6dB range)

500 Hz to 5 kHz (-3dB range)

Allowable load resistance: 230 to 600 Ω

Communication direction: Bi-directional (*)

* HART communication can only be used between the input and Output-1.

Maximum number of connectable HART communication devices: 1

Trademarks: HART is a registered trademark of the FieldComm Group.

■ Standard Performance

Accuracy rating: $\pm 0.1\%$ of span (aside from the $\pm 0.1\%$ accuracy of the external resistor for current input); accuracy is not guaranteed for output levels less than 0.5% of the span of a 0 to X mA output range type.

Response speed: 150 ms, 63% response (10 to 90%)
For option codes /C and /HC: 25 ms, 63% response (10 to 90%)

Effect of power supply voltage fluctuation: Accuracy range or less of span for power supply voltage fluctuation.

Effect of ambient temperature change: $\pm 0.15\%$ or less of span for change of 10 $^{\circ}\text{C}$

■ Safety and EMC Standards

CSA: CSA 22.2 No. 61010-1, installation category II (*1), pollution degree 2 (*2), and CSA C22.2 No. 61010-2-030

UL: UL61010-1, UL 61010-2-030 (CSA NRTL/C)

CE:

EMC directive

EN 61326-1 compliance, Class A Table 2 (*3)

EN 61326-2-3 compliance

EN 61000-3-2 compliance

EN 61000-3-3 compliance

EN 55011 Class A Group 1

Low voltage directive:

EN 61010-1, EN 61010-2-030

Installation category II (*1)

Pollution degree 2 (*2)

Measurement category O (other)

EMC Regulatory Arrangement in Australia and New Zealand (RCM): EN 55011 Class A, Group 1
KC marking: Electromagnetic wave interference prevention standard, electromagnetic wave protection standard compliance

- *1 Installation category (overvoltage category) II: Describes a number which defines a transient overvoltage condition. Implies the regulation for impulse withstand voltage.
"II" applies to electrical equipment which is supplied from the fixed installation like a distribution board.
- *2 Pollution degree 2: Describes the degree to which a solid, liquid, or gas which deteriorates dielectric strength or surface resistivity is adhering.
"2" applies to normal indoor atmosphere. Normally, only non-conductive pollution occurs.
- *3 The instrument continues to operate at a measurement accuracy of within $\pm 20\%$ of the range during testing.

However, if optional code /C0 or /FB is specified, the conformity to the safety and EMC standards is excluded.

■ Environment Standard

RoHS Directive: EN 50581

(However, when option code /C0 or /FB is specified, CE marking is not applicable because the product does not comply with the Safety and EMC standards.)

■ Power Supply and Isolation

Supply rated voltage range: 100-240 V AC/DC \approx 50/60 Hz or 15-30 V DC \approx

Supply input voltage range: 100-240 V AC/DC \approx (-15, +10%) 50/60 Hz or 15-30 V DC \approx ($\pm 20\%$)

Power consumption: 2.2 W at 24 V DC; 2.1 W at 110 V DC; 4.2 VA at 100 V AC; 6.1 VA at 200 V AC

Insulation resistance: 100 M Ω minimum at 500 V DC between input, output-1, output-2, power supply and grounding terminals mutually

Withstanding voltage: 2000 V AC for one minute between input, (output-1 and output-2), power supply and grounding terminals mutually;
1000 V AC for one minute between output-1 and output-2 terminals

■ Environmental Conditions

Temperature: -10 to 55 $^{\circ}\text{C}$ (45 $^{\circ}\text{C}$ or less for side-by-side close installation*)

* If the previous model (style S3.xx earlier) is installed together, the ambient temperature is 0 to 40 $^{\circ}\text{C}$.

Humidity: 5 to 90 % RH (no condensation)

Ambient Condition: Avoid installation in such environments as corrosive gas like sulfide hydrogen, dust, sea breeze and direct sunlight.

Magnetic field: 400 A/m or less.

Continuous vibration (at 5 to 9 Hz) Half amplitude of 3 mm or less (at 9 to 150 Hz) 4.9 m/s² or less, 1 oct/min for 90 minutes each in the 3-axis directions.

Impact: 98 m/s² or less, 11 msec, 3-axis 3 times each in 6 directions.

Altitude: 2000 m or less.

Warm-up time: At least 30 minutes after power on.

Transport and Storage Conditions

Ambient temperature: -25 to 70 °C
 Temperature change rate: 20 °C per hour or less
 Ambient humidity: 5 to 95 %RH (no condensation)

Mounting and Appearance

Construction: Compact plug-in type
 Material: Modified polyphenylene oxide (casing)
 Mounting method: Wall, DIN rail or dedicated VJ mounting base (VJCE) mounting
 Connection method: M3 screw terminals
 External dimensions:
 76 (H) × 29.5 (W) × 124.5 (D) mm (including a socket)
 Weight: Main unit: 100 g or less
 Socket: 50 g or less

Accessories

Tag number label: One
 Resistor (Shunt resistor): One (attached for current input *)

Resistance	Part No.	Resistance	Part No.
100 Ω	E9786WD	500 Ω	E9786WF
250 Ω	E9786WE	1 kΩ	E9786WG

* Excluding option codes /C and /HC.

Customized Signal Specifications

Input custom specification

- Customized specifications complying with safety standards, EMC standards, and environmental standards

Input range (DC)	Standard span (DC)	Input resistance	
-0.025 to 0.025 V	0.01 V	1 MΩ during power on 10 kΩ or more during power off	
-0.125 to 0.125 V	0.04 V		
-1.25 to 1.25 V	0.4 V		
-2.5 to 2.5 V	1 V		
-12.5 to 12.5 V	4 V		
-25 to 25 V	8 V	1 MΩ during power on 800 kΩ or more during power off	
-0.1 to 0.1 mA	0.04 mA		
-1 to 1 mA	0.4 mA		
-5 to 5 mA	4 mA		
-10 to 10 mA	8 mA		500 Ω
-20 to 20 mA ^{*1}	16 mA		250 Ω
-50 to 50 mA ^{*2}	40 mA		100 Ω
			1 kΩ

*1 The following can not be produced.

Input range (DC)	Input span (DC)
-20 to -16.8 mA	3.2 mA or less
16.8 to 20 mA	

*2 The following can not be produced.

Input range (DC)	Input span (DC)
-50 to -30 mA	20 mA or less
30 to 50 mA	

Accuracy rating: ±0.1% of span^{*5}

- Customized specifications that do not comply with safety standards, EMC standards, and environmental standards

Input range (DC)	Standard span (DC)	Input resistance
-100 to 100 V	40 V	1 MΩ during power on 800 kΩ or more during power off
-200 to 200 V	80 V	
-300 to 300 V	120 V	
-70 to 70 mA ^{*3}	80 mA	50 Ω
-150 to 150 mA ^{*4}	100 mA	10 Ω

*3 The following can not be produced.

Input range (DC)	Input span (DC)
-70 to -42 mA	28 mA or less
42 to 70 mA	

*4 The following can not be produced.

Input range (DC)	Input span (DC)
-150 to -90 mA	60 mA or less
90 to 150 mA	

Accuracy rating: ±0.1% of span^{*5}

*5 Accuracy restrictions

When the input span is less than the standard span, the accuracy calculated by the following formula is applied.

$$\text{Accuracy rating (\%)} = \pm 0.1\% \times \frac{\text{Standard span}}{\text{Input span}}$$

Other restrictions

- The input span is 1/10 or more of the standard span

Output custom specification

	Current Signal	Voltage Signal
Output range (DC)	0 to 24 mA	-10 to +10 V
Span (DC)	1 to 24 mA	10 mV to 20 V
Zero elevation	0 to 200%	-100 to +200%

Note: Customized specifications for the output-1 signal within 0 to 20 mA DC or within -10 to +10 V DC comply with safety standards, EMC standards, and environmental standards.

- The above note is limited to the standard specification of output-2.
- Other customized specifications do not conform to these standards.

Terminal Assignments

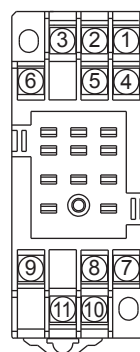

1	Input	(+)
2	Output-2	(+)
3	Input	(-)
4	Do not use	
5	Output-2	(-)
6	Do not use	
7	Output-1	(+)
8	GND	
9	Output-1	(-)
10	Supply	(L+)
11	Supply	(N-)

Do not use output-2 for the single-output type.

■ Block Diagram

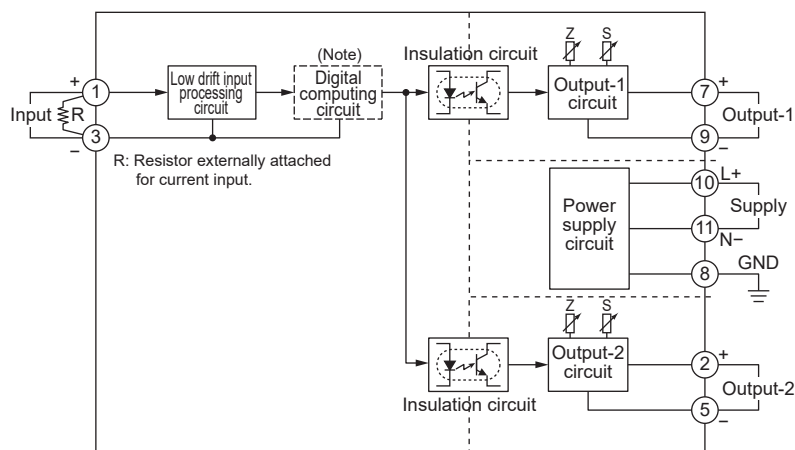

Note: Digital computing circuit is added for the input/output suffix codes other than "A" and "6".

For option codes /C and /HC

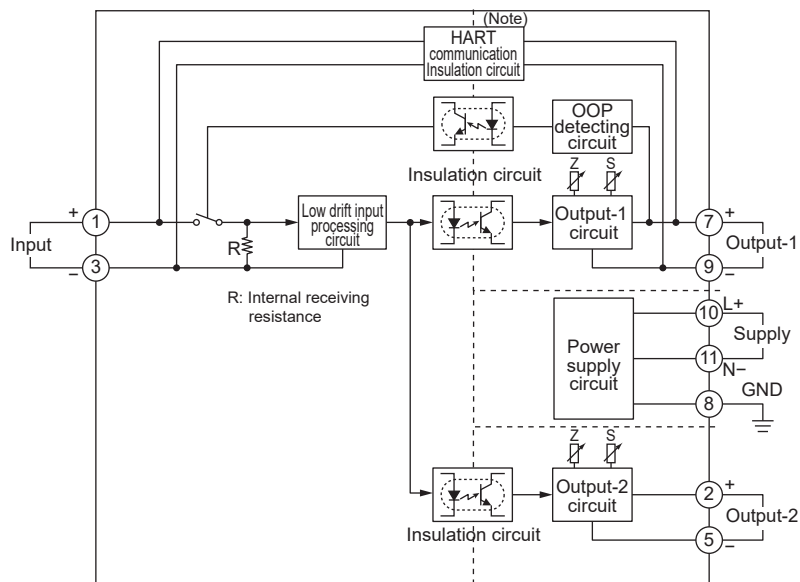

Note: The HART communication isolation circuit is added when the option code / HC is specified.

External Dimensions

