

TRANSIC Extractive



Beschriebenes Produkt

Produktname: TRANSIC Extractive
Dokument ID.: 8021262

Manufacturer

SICK AG
Erwin-Sick-Str. 1 · 79183 Waldkirch · Germany
Telefon: +49 7641 469-0
Fax: +49 7641 469-1149
E-Mail: info.pa@sick.de

Production location

SICK AG
Nimburger Str. 11 · 79276 Reute · Germany

Legal information

This work is protected by copyright. Any rights derived from the copyright shall be reserved for SICK AG. Reproduction of this document or parts of this document is only permissible within the limits of the legal determination of Copyright Law. Any modification, expurgation or translation of this document is prohibited without the express written permission of SICK AG.

The trademarks stated in this document are the property of their respective owner.

© SICK AG. All rights reserved

Original document

This document is an original document of SICK AG.

Content

- 1 About this Document 5**
 - 1.1 Limitation of Liability..... 5
 - 1.2 Purpose of this Document 5
 - 1.3 Target Group..... 5
 - 1.4 Further Information..... 5
 - 1.5 Additional Technical Documentation 6
 - 1.6 Document Conventions..... 6

- 2 Important Safety Instructions 7**
 - 2.1 Supplemental Directives..... 7
 - 2.2 Safety Conventions 7
 - 2.3 Warning Signs 8
 - 2.4 Mandatory symbols conventions..... 8
 - 2.5 Safety Messages 8
 - 2.6 Notices..... 9
 - 2.7 Intended Use 10
 - 2.7.1 RoHS Directive 10
 - 2.7.2 Measured components..... 10
 - 2.7.3 Measuring range..... 10
 - 2.8 Requirements for the Qualification of Personnel 10

- 3 System Description 11**
 - 3.1 Characteristics 11
 - 3.2 Gas Flow Diagram 12
 - 3.3 Method of Operation 13
 - 3.3.1 Settings 13

- 4 Installation 15**
 - 4.1 Mounting Plate 15

- 5 Operation 17**
 - 5.1 Interfaces 17
 - 5.1.1 Keypad 17
 - 5.2 Maintenance Interface..... 18

- 6 Maintenance..... 19**

- 7 Technical Data 21**

- 8 Disposal..... 23**

1 About this Document

**Note**

This document regarding the TRANSIC Extractive:

- Contains information required during the life cycle of the System.
- Is available to all those people who work with the System.

Please read this document carefully and make sure that you understand the content fully before working with the System.

1.1 Limitation of Liability

**Note**

Applicable standards and regulations, the latest state of technological development and many years of knowledge and experience have all been taken into account, when assembling the data and information contained in this document.

The manufacturer accepts no liability for damage caused by:

- Failing to observe this document.
- Non-compliance of notices and regulations.
- Unauthorized installation and mounting of the TRANSIC Extractive.
- Arbitrary modifications.
- Use of unauthorized spare parts, consumables and accessories.

With special variants, where optional extras have been ordered, or owing to the latest technical changes, the actual scope of delivery may vary from the features and illustrations shown here.

1.2 Purpose of this Document

This document describes the TRANSIC Extractive.

1.3 Target Group

This document is intended for qualified personnel which are authorized to perform installation, operation, and maintenance on the TRANSIC Extractive.

1.4 Further Information

Special local conditions

Follow all local laws, technical rules, and company-internal operating directives applicable at the respective installation site of the TRANSIC Extractive.

Preserving the documents

This document and the additional technical documentation and information must be:

- Available for reference
- Passed on to new owners

1.5 Additional Technical Documentation

- Operating instructions of the following system components:

Component	Manufacturer
OI_TRANSIC151LP	SICK

- Technical System-Documentation (EPLAN) contains:
 - Technical Data
 - Wiring diagram
 - Gas flow diagram

1.6 Document Conventions

- ▶ Instruction



Refer to another document.

All units of measurement in this document are originally metric units.
Subject to change without notice. Images might differ from actual design.

2 Important Safety Instructions



Note

Read and follow all safety instructions in this document.

2.1 Supplemental Directives



WARNING

- ▶ Read and understand this document carefully prior to working on the system or any other of its components.
- ▶ Only fully trained professionals from the respective field are permitted to work on the system.
- ▶ Follow all operational procedures.
- ▶ Follow all local regulations.
- ▶ Follow all local regulations regarding working with gas and electrical components.
- ▶ Entry to system area is only permitted to authorized personnel.
- ▶ Wear personal protective equipment (PPE) while on the system area.



2.2 Safety Conventions

Symbols on system and system components labels, safety labels and in safety messages inside this document are according to the current standards.

The following conventions for signal words are used in this document, complying with ANSI Z535.6:



DANGER

DANGER indicates a hazardous situation with a high risk level, which if not avoided, will result in death or serious injury.



WARNING

WARNING indicates a hazardous situation with a middle risk level, which if not avoided, could result in death or serious injury.



CAUTION

CAUTION indicates a potentially dangerous situation with a low risk level, which if not avoided may lead to minor or moderates injuries.

NOTICE









NOTICE is used to address practices not related to personal injury but to property damages.



Note

Indicates important information and useful hints.

2.3 Warning Signs

Sign	Significance
	Hazard (general)
	Hazard by voltage
	Hazard in potentially explosive areas
	Risk of explosion
	Hazard by laser
	Hazard by oxidizing substances
	Hazard by hot surfaces
	Hazard for the environment, nature and organic life

2.4 Mandatory symbols conventions

Symbol	Significance
	Refer to another document

2.5 Safety Messages

 **DANGER**

 **LASER Protection Class 1**
 Hazard by laser. Serious injuries.
 ▶ Do not place reflective objects directly into the probe.

 **DANGER**

 **RISK BY OXIDATION PROCESS**
 Death or serious injury will occur.
 ▶ Check ambient conditions before start installation and/or commissioning.

NOTICE

ELECTROSTATIC CHARGE
 Note the ESD regulations. Do not touch components inside the enclosure, these can be damaged.

**DANGER****HAZARDOUS VOLTAGE**

The system is supplied with mains voltage from the grid. Danger of electrocution - contact will cause electric shock, burn or death.



- ▶ Only qualified personnel can perform electrical works on the system.
- ▶ Always exercise caution when handling cables and connectors.
- ▶ Before working on the system:
 - ▶ Follow operational procedures such as Lockout-Tagout.
 - ▶ Check that there is no residual voltage by measuring AC voltages.

**WARNING****FLAMMABLE OR EXPLOSIVE GAS MIXTURE**

Serious injuries.



- ▶ To avoid inflammable or explosive gas mixtures we recommend to use only Nitrogen (N₂) as propellant gas.
- ▶ If an inflammable or explosive gas mixtures can not be avoided ensure proper treatment or disposal (exhaust) after sample gas outlet.
- ▶ If calibrating the TRANSIC151LP with ambient air, ensure proper treatment or disposal (exhaust) after sample gas outlet.

2.6 Notices**NOTICE****SYSTEM WARRANTY**

If you disregard the safety and hazard precautions, no warranty claim for damages will be honored. If you alter parts of the System by your own initiative, all warranty claims will be forfeited.

- ▶ Regard all safety and hazard precautions.
- ▶ Use only material supplied or approved by SICK for the system maintenance.
- ▶ Do not alter the system.

NOTICE**SYSTEM DAMAGE**

Damage to any system components or parts can lead to malfunction of the entire System. Do not ignore damaged or broken parts, refer to this manual and contact SICK support immediately.

- ▶ Do not install damaged parts.

2.7 Intended Use

The TRANSIC Extractive is a stationary system and serves continuous measurement of oxygen in the industrial sector.

The sample gas is taken from a sampling point and feed through the gas analyzer (extractive measurement).

Operation in explosion-hazard areas

Suitable for areas according to ATEX and IECEx (IEC 60079-10).



For further and detailed information about intended use of the TRNSIC151LP, refer to the respective Operating Instructions.

2.7.1 RoHS Directive

This product is designed for applications in large industrial plants according to Article 2 (4) e, RoHS 2011/65/EU and can therefore only be used in such systems.

The product is neither suitable nor approved for use outside of these systems. SICK cannot assume any kind of warranty or liability for use outside of these systems.

2.7.2 Measured components

Gases	O ₂ (Oxygen)
-------	-------------------------

2.7.3 Measuring range

Component	Range	Unit
O ₂	0 ... 21	%
	0 ... 100	%
ambient measurement	2 ... 21	%

2.8 Requirements for the Qualification of Personnel



Note Qualified personnel

- Qualified personnel have the specialist training, skills, and experience, as well as knowledge of the relevant regulations and standards, to be able to perform tasks delegated to them and to detect and to avoid any potential dangers independently.
 - Electricians have the specialist training, skills, and experience, as well as knowledge of the relevant standards and provisions to be able to carry out work on electrical systems and to detect and avoid any potential dangers independently.
-

3 System Description

3.1 Characteristics

The TRANSIC Extractive is an analysis system to measure and monitor oxygen.

The TRANSIC Extractive works extractive, i.e. the gas to be measured is taken from the gas duct using a gas extraction probe or probes and fed to the analysis system via sample gas line(s).

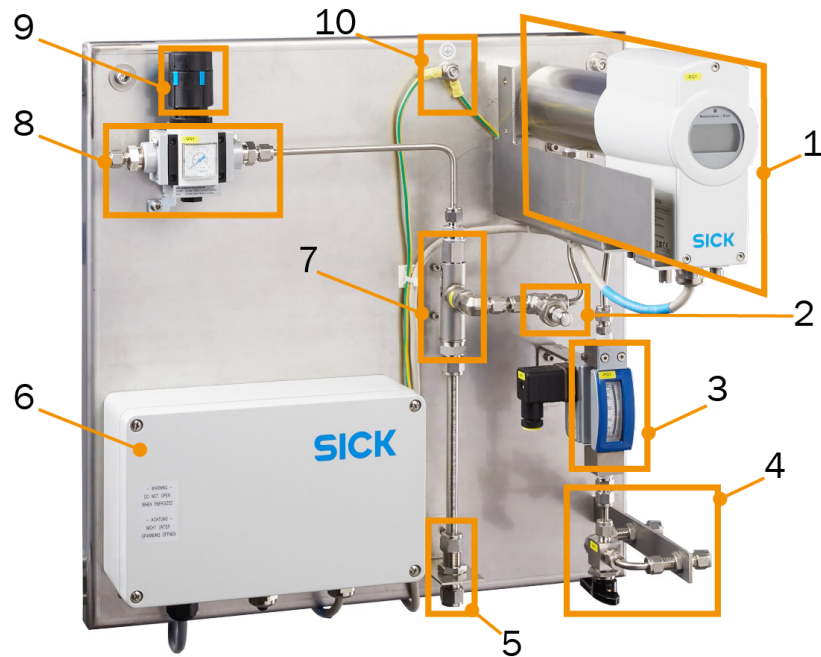

Fig. 1: TRANSIC Extractive system components

Legend

- | | |
|----|---------------------------------------|
| 1 | TRANSIC151LP |
| 2 | Needle valve |
| 3 | Flow meter |
| 4 | Manual valve sample gas/reference gas |
| 5 | Sample and propellant gas outlet |
| 6 | Voltage supply unit |
| 7 | Injector pump |
| 8 | Propellant gas inlet |
| 9 | Pressure reducer |
| 10 | Grounding point |

3.2 Gas Flow Diagram

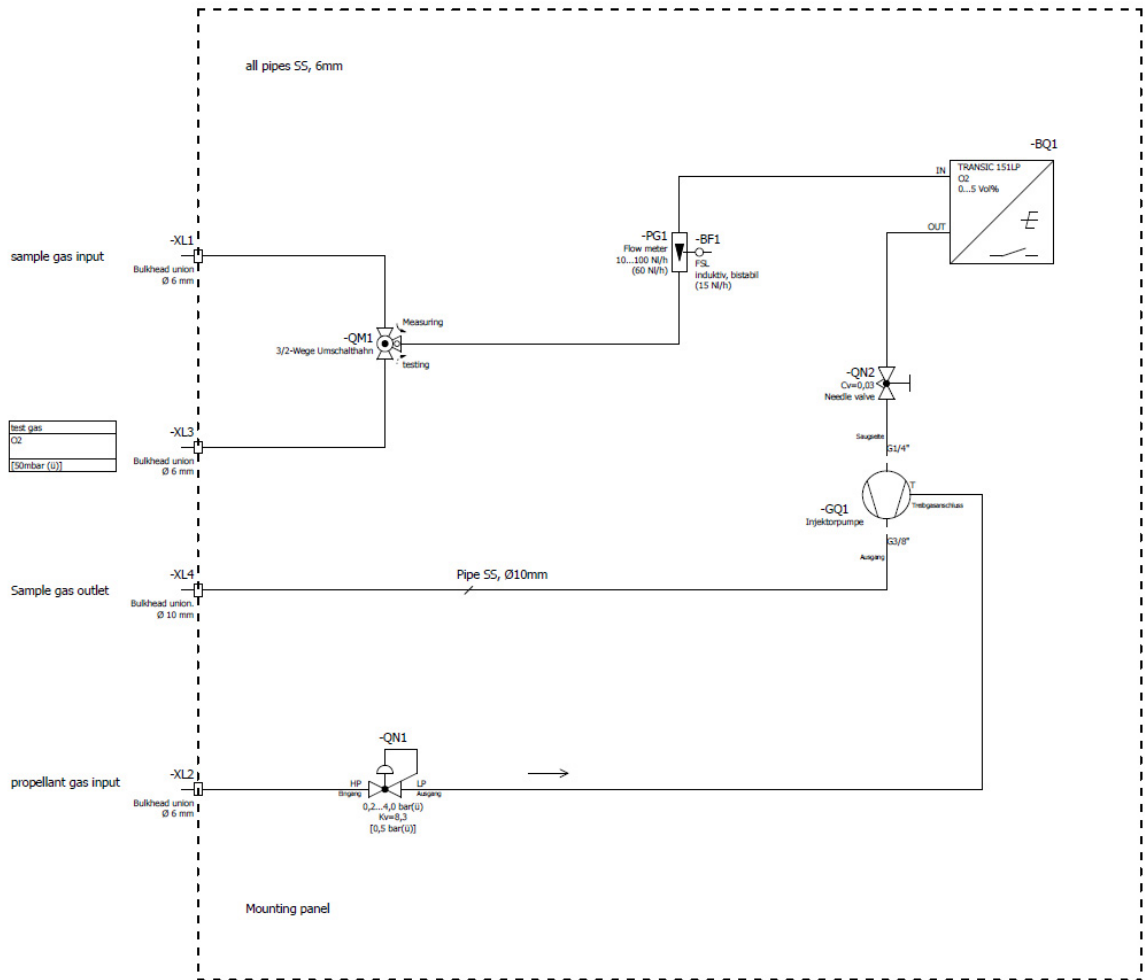

Fig. 2: TRANSIC Extractive gas flow diagram

3.3 Method of Operation

The sample gas is fed through gas analyzer and flow meter via injector pump. The sample gas and the propellant gas are mixed in the injector pump. This gas mixture is fed to the sample gas outlet.



WARNING



FLAMMABLE OR EXPLOSIVE GAS MIXTURE

Serious injuries.



- ▶ To avoid inflammable or explosive gas mixtures we recommend to use only Nitrogen (N₂) as propellant gas.
- ▶ If an inflammable or explosive gas mixtures can not be avoided ensure proper treatment or disposal (exhaust) after sample gas outlet.
- ▶ If calibrating the TRANSIC151LP with ambient air, ensure proper treatment or disposal (exhaust) after sample gas outlet.

3.3.1 Settings

The sample flow rate can be adjusted via needle valve and/or propellant gas pressure reducer:

- ▶ Needle valve open - higher sample gas flow.
- ▶ Needle valve close - lower sample gas flow.
- ▶ Higher propellant gas pressure - higher sample gas flow.
- ▶ Lower propellant gas pressure - lower sample gas flow.
- ▶ For calibration with ambient air or reference gases sample gas inlet can be switched via manual valve.



For further and detailed information about calibration of the TRANSIC151LP, refer to the respective Operating Instructions.

3 SYSTEM DESCRIPTION

4 Installation

4.1 Mounting Plate

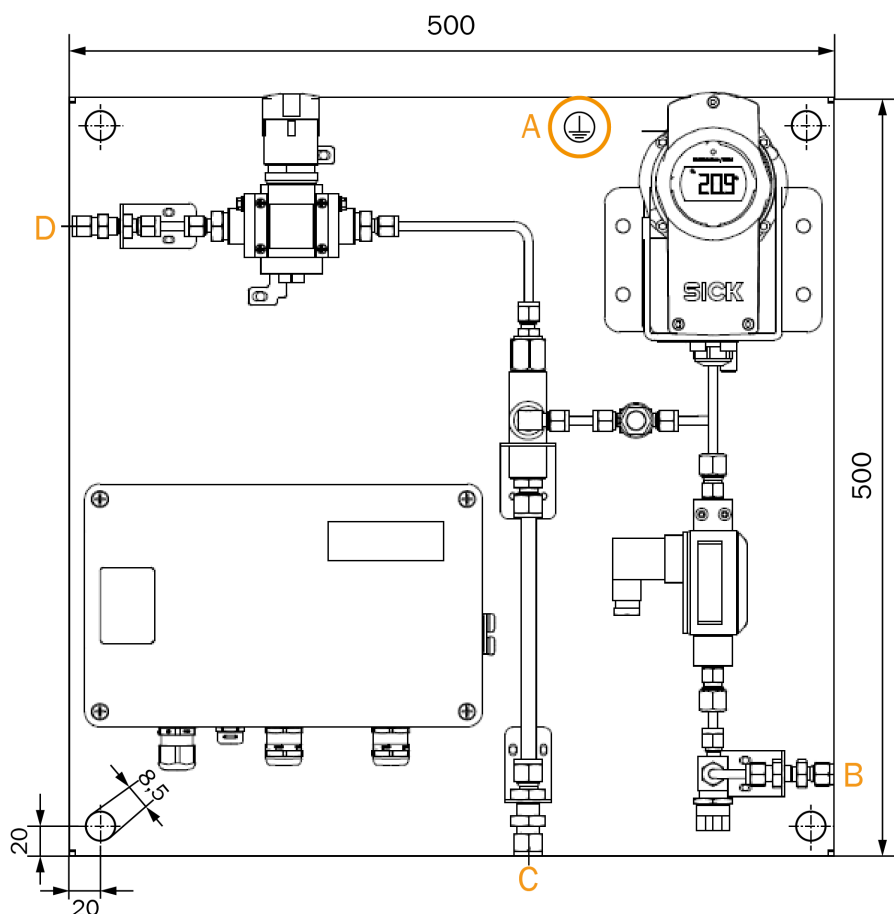

Fig. 3: Mounting plate dimensions/connections

- ▶ Appropriate installation site:
 - Wall
 - Frame
 - Rack
- ▶ Appropriate fixing material
 - Bolts
 - Nuts
 - Dowels
 - Anchoring
- ▶ (A) Grounding point
- ▶ Line connectors
 - (B) Sample and reference gas connectors: Swagelok 6 mm (2x)
 - (C) Sample gas exhaust: Swagelok 10 mm
 - (D) Propellant gas inlet: Swagelok 6 mm

5 Operation

5.1 Interfaces

- Keypad
- Maintenance interface



Note

Changes to parameters are password protected. The password allows access for 30 minutes after entry.

5.1.1 Keypad

A display and four pushbuttons are located on the front enclosure panel. The measured oxygen is shown on the display. LEDs signal the operating mode.

Characteristics Calibration of:

- Process pressure
- Humidity
- Carbon dioxide content

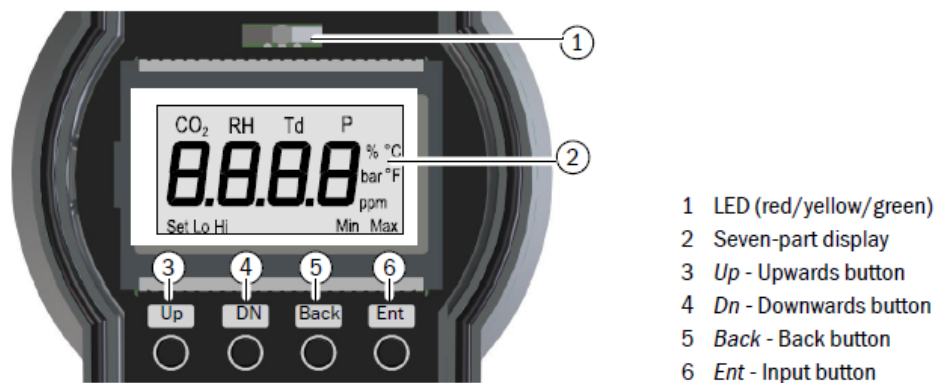

- 1 LED (red/yellow/green)
- 2 Seven-part display
- 3 Up - Upwards button
- 4 Dn - Downwards button
- 5 Back - Back button
- 6 Ent - Input button

Fig. 4: Keypad (source: TRANSIC151LP operating instructions)

Display modes

Display mode	Display/LED	Process
Start (duration: 2,5 minutes)	Software Version Self test Pass	Self-test starts Information: Self-test running Warming up phase starts
Normal operation	Green LED remains on Measured oxygen value	Measured oxygen value is shown continuously
Error state	Red LED remains on Error state number	
Warning	Yellow LED flashes Measured oxygen value is displayed	Select function "Err" in the menu

5.2 Maintenance Interface

The maintenance interface is located on the connector block above the display.

- Functions**
- Maintenance
 - Calibration
 - Changing parameters
 - Configuration of alarm thresholds



For further and detailed information about operation, maintenance, and calibration of the TRANSIC151LP, refer to the respective Operating Instructions.

6 Maintenance



For further and detailed information about maintenance of the TRANSIC151LP, refer to the respective the Operating Instructions.

7 Technical Data

The exact device specifications and performance data of the product may deviate from the information provided here, and depends on the respective application and customer specifications.

Measured value	O ₂
Max. number of measured values	1
Measuring principle	Diode laser spectroscopy (TDLS)
Measuring ranges	O ₂ : 0 ... 5 Vol.-% / 0 ... 100 Vol.-%
Response time (t ₉₀)	≤ 10 s
Accuracy	≤ 0,2 Vol.-%
Zero point drift	± 0,1 Vol.-% per year
Process temperature	-20 °C ... 200 °C (other temperature ranges on request)
Process pressure	800 hPa ... 15.000 hPa (further pressure ranges on request)
Ambient temperature	-20 °C ... +60 °C
Storage temperature	-20 °C ... +80 °C
Ex-approvals - IECEx	Sender/receiver unit: II 1/2G Ex ib IIB T4 Gb; II 2D Ex ib tb IIIC T85 °C Db Measuring probe: II 1/2G Ex op is IIB T4 Ga; II 2D Ex ib tb IIIC T85 °C Db Power supply: II 2G Ex e mb [ib] IIB T4 Gb; II 2D Ex tb [ib] IIIC T85 °C Db
Ex-approvals - ATEX	Sender/receiver unit: II 1/2G Ex ib IIB T4 Gb; II 2D Ex ib tb IIIC T85 °C Db Measuring probe: II 1/2G Ex op is IIB T4 Ga; II 2D Ex ib tb IIIC T85 °C Db Power supply: II 2G Ex e mb [ib] IIB T4 Gb; II 2D Ex tb [ib] IIIC T85 °C Db
Ex-approvals - NEC/CEC (US/CA)	Sender/receiver unit: Class I, Division 2, Group A, B, C, D T4 Measuring probe: Class I, Division 1 + 2, Group A, B, C, D T4
Electrical safety	CE
Protection class	IP66
Analog outputs	1 output: 0/4 ... 20 mA, 500 Ω 1 output: 0/4 ... 20 mA, 200 Ω Only for ATEX/IECEx version TRANSIC151LP.
Digital outputs	1 relay contact: 30 V AC, 1 A/60 V DC, 0,5 A 1 NAMUR output: Only for ATEX/IECEx version TRANSIC151LP.
Interfaces	RS-485 (not for ATEX/IECEx version) RS-232c (Service interface; not in ATEX/IECEx design) USB (not approved for Ex-applications)
Dimensions (W x H x D) (depending on version)	500 x 500 x 400 mm / 19.68 x 19.68 x 15.74 in
Weight (depending on configuration)	15 ... 30 kg / 33.06 ... 66.13 lbs

Power supply - Voltage	24 V DC TRANSIC151LP: 21,6...26,4 V For ATEX/IECEX version via TSA151, a PELV power supply is mandatory
Power supply - Current consumption	≤ 500 mA TRANSIC151LP: ≤ 240 mA (depending on version)
Power consumption	≤ 6 W TRANSIC151LP: $\leq 5,2$ W (depending on version)
Corrective functions	Adjustment with ambient air or test gases
Test functions	Contamination check

8 Disposal



Note

Note the relevant currently valid local and legal environment regulations and directives for the disposal of industrial and electronic waste.

NOTICE

DISPOSAL OF BATTERIES, ELECTRIC- AND ELECTRONIC DEVICES

- ▶ According to the European Directives, batteries, accumulators and electrical or electronic devices must not be disposed of in general waste.
- ▶ The owner is obliged by law to return this devices at the end of their life to the respective public collection points.
- ▶ This symbol on the product, its package or in this document, indicates that a product is subject to these regulations.



The following assemblies may contain substances which must be disposed of separately:

- **Electronic:**
Capacitors, accumulators, batteries.
- **Displays:**
Liquid in the LC-Displays.
- **Sample gas lines:**
Toxic substances of the sample gas could be penetrated or adhered into soft materials of the gas path (e. g. hoses, seal rings). Please check if such effects must be taken into account during disposal.
- **Analyzer modules:**



For detailed information to the disposal of analyzer modules, refer to the respective Operating Instructions.

Australia

Phone +61 3 9457 0600
1800 334 802 – tollfree
E-Mail sales@sick.com.au

Austria

Phone +43 22 36 62 28 8-0
E-Mail office@sick.at

Belgium/Luxembourg

Phone +32 2 466 55 66
E-Mail info@sick.be

Brazil

Phone +55 11 3215-4900
E-Mail marketing@sick.com.br

Canada

Phone +1 905 771 14 44
E-Mail information@sick.com

Czech Republic

Phone +420 2 57 91 18 50
E-Mail sick@sick.cz

Chile

Phone +56 2 2274 7430
E-Mail info@schadler.com

China

Phone +86 20 2882 3600
E-Mail info.china@sick.net.cn

Denmark

Phone +45 45 82 64 00
E-Mail sick@sick.dk

Finland

Phone +358-9-2515 800
E-Mail sick@sick.fi

France

Phone +33 1 64 62 35 00
E-Mail info@sick.fr

Germany

Phone +49 211 5301-301
E-Mail info@sick.de

Hong Kong

Phone +852 2153 6300
E-Mail ghk@sick.com.hk

Hungary

Phone +36 1 371 2680
E-Mail office@sick.hu

India

Phone +91 22 4033 8333
E-Mail info@sick-india.com

Israel

Phone +972 4 6881000
E-Mail info@sick-sensors.com

Italy

Phone +39 02 274341
E-Mail info@sick.it

Japan

Phone +81 3 5309 2112
E-Mail support@sick.jp

Malaysia

Phone +6 03 8080 7425
E-Mail enquiry.my@sick.com

Mexico

Phone +52 472 748 9451
E-Mail mario.garcia@sick.com

Netherlands

Phone +31 30 2044 000
E-Mail info@sick.nl

New Zealand

Phone +64 9 415 0459
0800 222 278 – tollfree
E-Mail sales@sick.co.nz

Norway

Phone +47 67 81 50 00
E-Mail sick@sick.no

Poland

Phone +48 22 539 41 00
E-Mail info@sick.pl

Romania

Phone +40 356 171 120
E-Mail office@sick.ro

Russia

Phone +7 495 775 05 30
E-Mail info@sick.ru

Singapore

Phone +65 6744 3732
E-Mail sales.gsg@sick.com

Slovakia

Phone +421 482 901201
E-Mail mail@sick-sk.sk

Slovenia

Phone +386 591 788 49
E-Mail office@sick.si

South Africa

Phone +27 11 472 3733
E-Mail info@sickautomation.co.za

South Korea

Phone +82 2 786 6321
E-Mail info@sickkorea.net

Spain

Phone +34 93 480 31 00
E-Mail info@sick.es

Sweden

Phone +46 10 110 10 00
E-Mail info@sick.se

Switzerland

Phone +41 41 619 29 39
E-Mail contact@sick.ch

Taiwan

Phone +886 2 2375-6288
E-Mail sales@sick.com.tw

Thailand

Phone +66 2645 0009
E-Mail Ronnie.Lim@sick.com

Turkey

Phone +90 216 528 50 00
E-Mail info@sick.com.tr

United Arab Emirates

Phone +971 4 88 65 878
E-Mail info@sick.ae

United Kingdom

Phone +44 1727 831121
E-Mail info@sick.co.uk

USA

Phone +1 800 325 7425
E-Mail info@sick.com

Vietnam

Phone +84 945452999
E-Mail Ngo.Duy.Linh@sick.com

Further locations at www.sick.com