

GM700

Laser Gas Analyzer
Probe Version

Protection Window for NH₃ and HF

SICK
Sensor Intelligence.

Described product GM700
Probe Version
GM700-02, GM700-04, GM700-05, GM700-07, GM700-09

Manufacturer SICK AG
Erwin-Sick-Str. 1
D-79183 Waldkirch
Germany

Production location SICK AG
Gisela-Sick-Str. 1
D-79276 Reute
Germany

Legal information This work is protected by copyright. Any rights derived from the copyright shall be reserved for SICK AG. Reproduction of this document or parts of this document is only permissible within the limits of the legal determination of Copyright Law. Any modification, abridgment or translation of this document is prohibited without the express written permission of SICK AG.

The trademarks stated in this document are the property of their respective owner.

© SICK AG. All rights reserved

Original document This document is an original document of SICK AG.



Contents

1	About this document.....	4
1.1	Additional documentation / information.....	4
2	Safety Information.....	4
2.1	Intended use	4
2.2	User qualification	4
3	Product overview.....	5
3.1	Product identification.....	5
3.2	Scope of delivery	5
3.3	Principle of operation.....	5
3.4	Layout and function	5
4	Installation	6
4.1	System component assembly and measuring point preparation	6
4.2	Tools required	6
4.3	Prerequisites	6
4.4	Installation sequence.....	6
5	Commissioning and operation.....	9
6	Maintenance.....	9
6.1	Qualification	9
6.2	Maintenance intervals and implementation.....	9
7	Troubleshooting	10
7.1	Purge-air failure.....	10
8	Technical data, consumables and spare parts	11
8.1	Protection window.....	11
8.2	Dimension drawings.....	11
8.3	Accessories, consumables and spare parts	11
9	Decommissioning.....	12
9.1	Safety instructions for decommissioning.....	12
9.2	Remove measuring system	12

1 About this document

This document describes the installation, commissioning and maintenance of the protection window in the event of a purge air failure.

This document is only applicable for the measuring device described in the product identification.

This document is intended for persons commissioning, operating and maintaining the device.

1.1 Additional documentation / information

- Operating Instructions for GM700 Probe (no. 8022447, English)
- Operating Instructions for SLV4 - Purge Air Unit (no. 8007692, English)
- Safety Information (no. 8019910, English)

You can download these documents from www.sick.com. To find a publication, enter the relevant part number in the search field.

2 Safety Information

- ▶ This document is only valid in connection with the documentation listed in section 1 of this document. Please read and observe the safety information and warning notices contained therein.
- ▶ Only put the device into operation when this document and the Operating Instructions have been read and understood. Contact SICK Customer Service should any questions arise.
- ▶ Refer to the device involved for the standards and guidelines of the Declaration of Conformity used.
- ▶ Keep this document, together with the Operating Instructions, available for reference and pass these on to a new owner.

2.1 Intended use

The protection window is part of the GM700 measuring system. This special version is used for emergency protection of the sender/receiver unit in the event of an accidental purge air failure. It is not a permanent substitute for a functioning purge air supply.

Otherwise, the manufacturer bears no responsibility and any warranty of the manufacturer expires.

2.2 User qualification

The device may only be operated by qualified persons who, based on their device-specific training and knowledge, as well as knowledge of the relevant regulations, can assess the tasks given and recognize the hazards involved.

3 Product overview

3.1 Product identification

Product name:	Protection window for purge air failure
For devices:	GM700-04/05/07/09, GM700-02
Device version:	Probe GMP
Manufacturer:	SICK AG Erwin-Sick-Str. 1 · D-79183 Waldkirch · Germany
Order information	2107166

3.2 Scope of delivery

- Protection window as a complete set
- 2 additional disc springs
- 3 screws for fixing

Not part of the scope of delivery (can be ordered externally):

- Sender/receiver unit
- Probe components
- Purge air supply
- Other components of the GM700 measuring system

3.3 Principle of operation

This accessory protects the sender/receiver unit of the GM700 measuring system in case of accidental and occasional failure of the purge air supply. Here, the sender/receiver unit is sealed by the protection window towards the process, so that no corrosive or wet process gas can penetrate into the sender/receiver unit and cause damage to the device.

The protection window does not represent a replacement for a purge air supply.

3.4 Layout and function

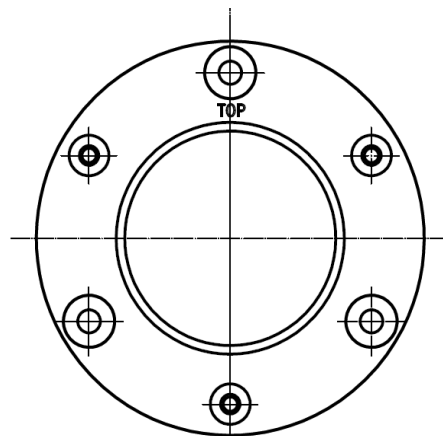

Protection window with marking for correct mounting

The protection window has to be mounted in an oriented way.

- The marking (colored point or writing „top“) must be upwards.

4 Installation

4.1 System component assembly and measuring point preparation

The installation procedure of the system components, such as probe, control unit, sender/receiver unit, and the preparation of the measuring point, including the mounting of the flange, can be found in the Operating Instructions of the corresponding measuring system GM700.

4.2 Tools required

- Torx wrench 20 mm – for mounting/replacing the protection window
- Screw wrench 19 mm – for optical fine alignment of the device

4.3 Prerequisites

- Make sure that the purge air supply is on (at least until the protection windows is mounted and fixed).

4.4 Installation sequence

4.4.1 First steps

1. Carry out a fine alignment of the GM700 measuring system to check the alignment of the system (see page 9).
2. Disconnect the power supply of the sender/receiver unit.

4.4.2 Separate the sender/receiver unit from the flange attachment

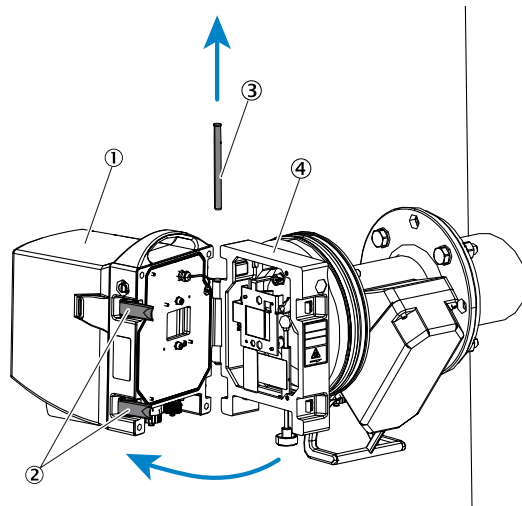

- ① Sender/receiver unit
- ② Quick-release fastener for the new housing
- ③ Hinge pin
- ④ Flange attachment

Steps:

1. Loosen the quick-release fasteners.
2. Pull the hinge pin upwards and remove the sender/receiver unit.

4.4.3 Dismount the flange attachment and insert the two additional disc springs

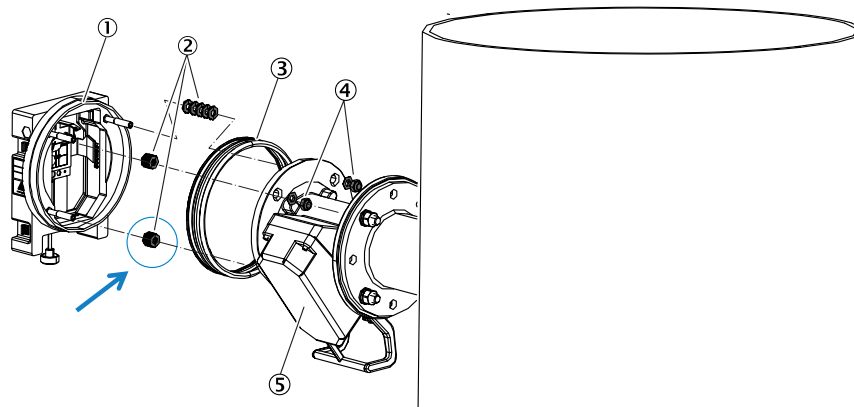

- ① Flange attachment sender/receiver unit
- ② Sets of disc springs (10 per attachment, individually facing each other)
- ③ Sealing ring
- ④ Mounting nut with centering disc
- ⑤ Purge air attachment

Steps:

1. Open the three mounting nuts at the device flange while holding it with one hand.
Be careful: Make sure that the centering disks do not fall out of the device flange.
2. Remove the flange attachment. Make sure that the disc springs remain on the 3 threaded bolts.
3. Add the 2 additional disc springs on the lower threaded bolt of the flange attachment.

4.4.4 Mount the protection window

1. Grease the sealing of the protection window.
Make sure that the optical window is kept clean.
2. Insert the protection window in the purge air attachment.
Make sure that the two marked holes point upwards.



IMPORTANT: In the protection window, a wedge window is installed oriented. Incorrect installation position leads to malfunction or complete dysfunction.

- ▶ If the protection window does not lie flat in the purge air attachment, press in lightly using the palm of the hand.
- ▶ Do not use extreme force or a hammer!

3. Fix the protection window with the 3 screws.

Before: without protection window

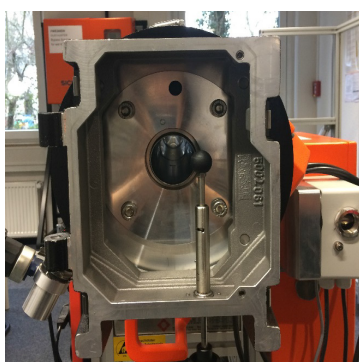

After: with protection window



4.4.5 Remount the flange attachment

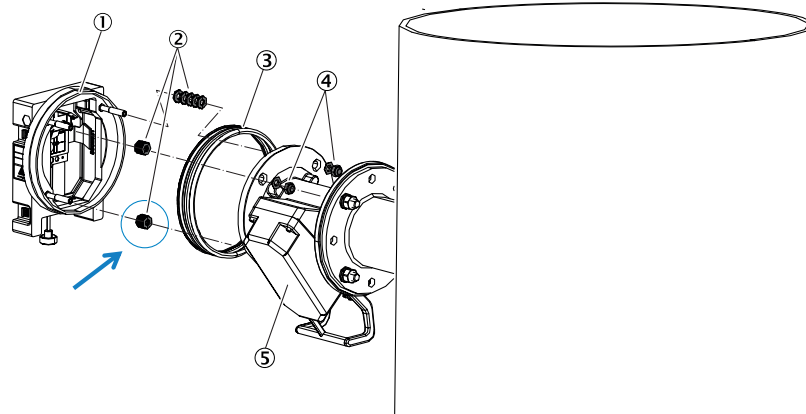

- ① Flange attachment sender/receiver unit
- ② Sets of disc springs (10 per attachment, individually facing each other)
- ③ Sealing ring
- ④ Mounting nut with centering disc
- ⑤ Purge air attachment

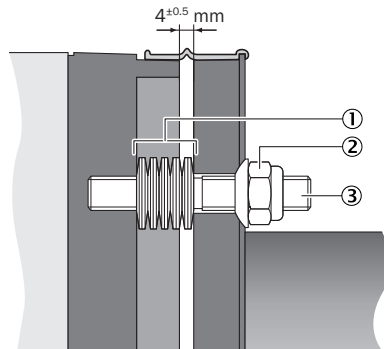

- ① Arrangement disc springs
- ② Self-locking nut with centering disc
- ③ Threaded bolt

Steps:



IMPORTANT: Make sure that the 2 additional disc springs have been mounted on the lower threaded bolt of the flange attachment.

4. Pull the sealing ring over the device flange and hang loosely over the purge air unit.
5. Place the flange attachment on the device flange.
6. Attach the centering discs.



IMPORTANT: Note the direction of the centering disc: The convex side must fit into the groove on the purge air adapter.

7. Tighten the self-locking nuts with a 19 mm open-end wrench so that the disc springs are slightly compressed and a uniform gap of approximately 4 mm remains.
8. Fix the sealing ring over the purge air attachment and the device flange.

4.4.6 Remount the sender/receiver unit on the flange attachments

Steps:

1. Follow the steps given in the Operating Instructions, chapter 7.7.



IMPORTANT: Before returning to normal operation, the power supply must be turned on and a fine adjustment carried out.

4.4.7 Carry out fine alignment

Steps:

1. Turn the power supply of the control unit on.
2. Follow the steps given in the Operating Instructions, chapter 7.9.

5 Commissioning and operation

No further steps are required.

6 Maintenance

6.1 Qualification

The checks and maintenance described in this chapter may be performed by service technicians using the equipment in accordance with the information in this manual.

The Operating Instructions and the Safety Instructions must be observed as well.

6.2 Maintenance intervals and implementation

The maintenance intervals depend on the individual application conditions and should be clarified in individual cases with SICK Service.

Recommendation:

- ▶ Check if the protection window is soiled on a regular basis.
- ▶ If protection window is soiled, dismount and clean.
- ▶ Clean the wedge window using isopropanol and clean pressured air or an optical cleaning tissue.

7 Troubleshooting

For malfunction of the measuring system, consult the corresponding Operating Instructions of the device and the Operation Instructions of the purge air unit.

7.1 Purge-air failure

7.1.1 Signs indicating a possible purge air failure

- Error message on systems equipped with a differential pressure switch
- Failure of the power supply of the purge air unit
- Enclosure temperature rise of the GM700 sender/receiver unit
- Rapidly rising contamination of the optical interface of the sender/receiver unit
- Visibly detached or damaged hose of the purge air supply to the purge air attachment
- Clogged or wet purge air filter

7.1.2 Actions in case of purge air failure

Materials required:

- Suitable protection equipment (protective clothing, gloves, etc.) to allow safe opening of the gas duct and removal of the sender/receiver unit and the reflector in the existing system conditions (hot/aggressive/harmful/dust-laden sample gases, overpressure in the duct)

Steps:

1. Check and clean purge air unit:
 - ▶ Remove dust and contamination.
 - ▶ Check air filter.
 - ▶ Check power supply.
2. Restore purge air supply: For details, see the Operating Instructions for the purge air unit.
3. Check protection window:
 - ▶ Either clean or replace the protection window.
 - ▶ If heavily soiled or damaged, replace the protection window.

8 Technical data, consumables and spare parts

8.1 Protection window

Materials	flange: aluminum, anodized
Wedge window	quartz/fused silica
Sealing	MVQ60 / NBR70
Mass	approx. 0,25kg
Dimensions	diameter: 68 mm, height: 22 mm
Process pressure range	± 50 hPa, relative
Process temperature range	< 100 °C

8.2 Dimension drawings

Front view

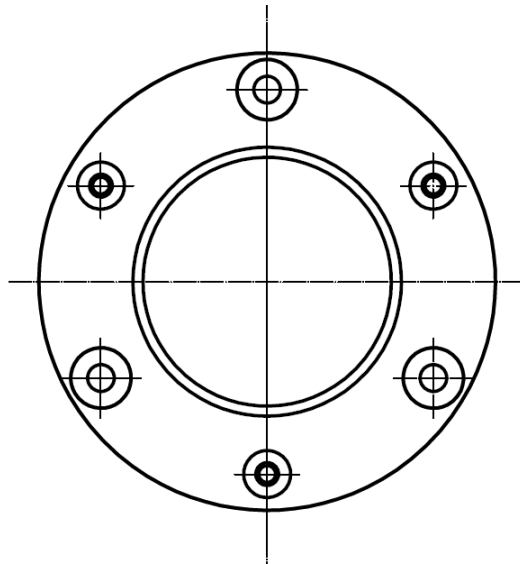

8.3 Accessories, consumables and spare parts

The respective accessories, consumables and spare parts of the standard version are available.

The protection window for purge air failure is a complete kit and can only be replaced in its entirety.

A repair is not provided for the protection window. Defective parts must be disposed of in accordance with local regulations.

9 Decommissioning

9.1 Safety instructions for decommissioning

See Operating Instructions of the respective measuring system.

9.2 Remove measuring system

1. See Operating Instructions of the measuring system.
2. Remove and clean the protection window.

Australia

Phone +61 (3) 9457 0600
1800 33 48 02 – tollfree
E-Mail sales@sick.com.au

Austria

Phone +43 (0) 2236 62288-0
E-Mail office@sick.at

Belgium/Luxembourg

Phone +32 (0) 2 466 55 66
E-Mail info@sick.be

Brazil

Phone +55 11 3215-4900
E-Mail comercial@sick.com.br

Canada

Phone +1 905.771.1444
E-Mail cs.canada@sick.com

Czech Republic

Phone +420 234 719 500
E-Mail sick@sick.cz

Chile

Phone +56 (2) 2274 7430
E-Mail chile@sick.com

China

Phone +86 20 2882 3600
E-Mail info.china@sick.net.cn

Denmark

Phone +45 45 82 64 00
E-Mail sick@sick.dk

Finland

Phone +358-9-25 15 800
E-Mail sick@sick.fi

France

Phone +33 1 64 62 35 00
E-Mail info@sick.fr

Germany

Phone +49 (0) 2 11 53 010
E-Mail info@sick.de

Greece

Phone +30 210 6825100
E-Mail office@sick.com.gr

Hong Kong

Phone +852 2153 6300
E-Mail ghk@sick.com.hk

Hungary

Phone +36 1 371 2680
E-Mail ertekesites@sick.hu

India

Phone +91-22-6119 8900
E-Mail info@sick-india.com

Israel

Phone +972 97110 11
E-Mail info@sick-sensors.com

Italy

Phone +39 02 27 43 41
E-Mail info@sick.it

Japan

Phone +81 3 5309 2112
E-Mail support@sick.jp

Malaysia

Phone +603-8080 7425
E-Mail enquiry.my@sick.com

Mexico

Phone +52 (472) 748 9451
E-Mail mexico@sick.com

Netherlands

Phone +31 (0) 30 229 25 44
E-Mail info@sick.nl

New Zealand

Phone +64 9 415 0459
0800 222 278 – tollfree
E-Mail sales@sick.co.nz

Norway

Phone +47 67 81 50 00
E-Mail sick@sick.no

Poland

Phone +48 22 539 41 00
E-Mail info@sick.pl

Romania

Phone +40 356-17 11 20
E-Mail office@sick.ro

Russia

Phone +7 495 283 09 90
E-Mail info@sick.ru

Singapore

Phone +65 6744 3732
E-Mail sales.gsg@sick.com

Slovakia

Phone +421 482 901 201
E-Mail mail@sick-sk.sk

Slovenia

Phone +386 591 78849
E-Mail office@sick.si

South Africa

Phone +27 10 060 0550
E-Mail info@sickautomation.co.za

South Korea

Phone +82 2 786 6321/4
E-Mail infokorea@sick.com

Spain

Phone +34 93 480 31 00
E-Mail info@sick.es

Sweden

Phone +46 10 110 10 00
E-Mail info@sick.se

Switzerland

Phone +41 41 619 29 39
E-Mail contact@sick.ch

Taiwan

Phone +886-2-2375-6288
E-Mail sales@sick.com.tw

Thailand

Phone +66 2 645 0009
E-Mail marcom.th@sick.com

Turkey

Phone +90 (216) 528 50 00
E-Mail info@sick.com.tr

United Arab Emirates

Phone +971 (0) 4 88 65 878
E-Mail contact@sick.ae

United Kingdom

Phone +44 (0)17278 31121
E-Mail info@sick.co.uk

USA

Phone +1 800.325.7425
E-Mail info@sick.com

Vietnam

Phone +65 6744 3732
E-Mail sales.gsg@sick.com

Detailed addresses and further locations at www.sick.com