

General Specifications

VJSS High/Low Signal Selector (Isolated Single-output and Isolated Dual-output Types)

JUXTA

GS 77J01S11-01E

General

The VJSS is a compact, plug-in high/low signal selector that selects the higher or lower of two DC input signals and converts it into an isolated DC voltage or DC current signals.

The VJSS selector features:

- a wide choice of output signal ranges;
- four isolated ports (input, output-1, output-2, power supply and grounding) on a dual-output model;
- a withstanding voltage of 2000 V AC;
- a wide supply voltage range - supporting both 100 V and 200 V power lines of AC or DC; and
- Various parameters such as input range can be set and modified using a PC (VJ77) or Handy Terminal (JHT200).
- close side-by-side mounting;

Model and Suffix Codes

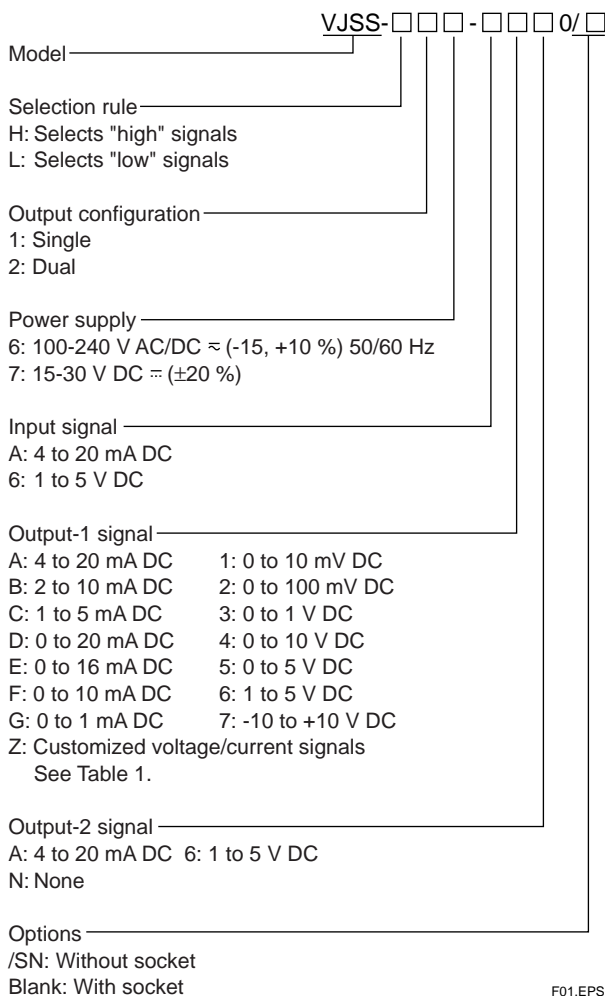

Items to be specified when ordering

- Model and Suffix Code: e.g. VJSS-H26-AAA0

Input/Output Specifications

Type of input: A pair of DC voltage or DC current signals, where both inputs share the same electrical specifications.

Input resistance: 250 Ω for 4 to 20 mA DC range
Approx. 1 M Ω for 1 to 5 V DC range (or 800 k Ω when turned off)

Output signal: DC voltage of DC current

Allowable load resistance:

Output 1 Output Range	Output Range
4 to 20 mA DC: 750 Ω maximum	0 to 10 mV DC: 250 k Ω minimum
2 to 10 mA DC: 1500 Ω maximum	0 to 100 mV DC: 250 k Ω minimum
1 to 5 mA DC: 3000 Ω maximum	0 to 1 V DC: 2 k Ω minimum
0 to 20 mA DC: 750 Ω maximum	0 to 10 V DC: 10 k Ω minimum
0 to 16 mA DC: 900 Ω maximum	0 to 5 V DC: 2 k Ω minimum
0 to 10 mA DC: 1500 Ω maximum	1 to 5 V DC: 2 k Ω minimum
0 to 1 mA DC: 15 k Ω maximum	-10 to +10 V DC: 10 k Ω minimum
Output 2 Output Range	Output Range
4 to 20 mA DC: 350 Ω maximum	1 to 5 V DC: 2 k Ω minimum

Input adjustment: \pm 1% of span (Zero/Span)

Output adjustment: \pm 5% of span (Zero/Span)

Standard Performance

Accuracy rating: \pm 0.1% of span (aside from the \pm 0.1% accuracy of the external resistor on current-input models); accuracy is not guaranteed for output level less than 0.5% of the span of a 0 to X mA output range type.

Selection sensitivity: 0.5% of span

Response: 150 ms for a 63% response (10 to 90% change of range)

Insulation resistance: 100 M Ω minimum at 500 V DC between input, output-1, output-2, power supply and grounding terminals mutually

Withstanding voltage: 2000 V AC for one minute between input, (output-1, output-2), power supply and grounding terminals mutually;
1000 V AC for one minute between output-1 and output-2 terminals

Operating temperature range: 0 to 50°C

Operating humidity range: 5 to 90% RH (no condensation)

Supply voltage range: 100-240 V AC/DC \approx (-15, +10%)
50/60 Hz or 15-30 V DC \approx (\pm 20%)

Effects of power line regulation: Up to \pm 0.1% of span for a supply voltage range of 85 to 264 V AC (47 to 63 Hz), 85 to 264 V DC or 12 to 36 V DC

Effects of ambient temperature variations: Up to $\pm 0.2\%$ of span per 10°C

Power Dissipation: 24V DC 2.3W, 10V DC 2.2W
100V AC 4.6VA, 200V AC 6.4VA

■ Conformance to EMC Standards

Applicable EMC standard: EN61326

CE-certified models mean those which are CE certified on condition that they be operated over a supply voltage range of 15-30 V DC \pm ($\pm 20\%$) only.

■ Mounting and Appearance

Material: ABS resin (casing)

Mounting: Wall mounting, DIN rail mounting, or mounting on a side-by-side multiple mounting base

Connection: Terminals with M3 size screws

External dimensions: 76 (H) \times 29.5 (W) \times 124.5 (D) mm

Weight: Main unit = approx. 120 g; socket = approx. 51 g

■ Accessories

Tag number label: One

Resistor module: Two (for current input model)

Customized Signal Specifications

Table 1 Manufacturable Ranges

	Current Signal	Voltage Signal
Output range	0 to 24 mA DC	-10 to +10 V DC
Span	1 to 24 mA DC	10 mV to 20 V DC
Zero elevation	0 to 200%	-100% to +200%

T01.EPS

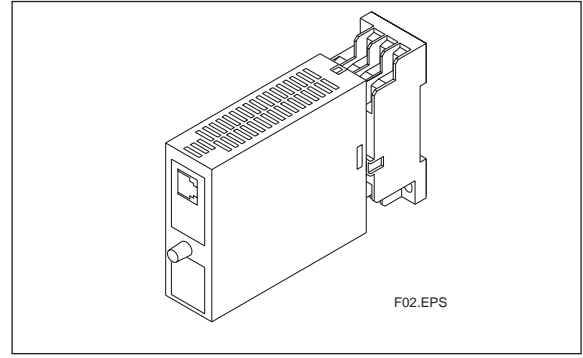

Terminal Assignments

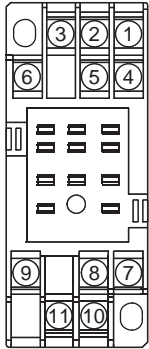

1	INPUT 1	(+)
2	OUTPUT 2	(+)
3	INPUT 1	(-)
4	INPUT 2	(+)
5	OUTPUT 2	(-)
6	INPUT 2	(-)
7	OUTPUT 1	(+)
8	GND	
9	OUTPUT 1	(-)
10	SUPPLY	(L+)
11	SUPPLY	(N-)

Note: For single-output models, OUTPUT2 is N.C.
Do not use N.C. terminal

F03.EPS

Block Diagram

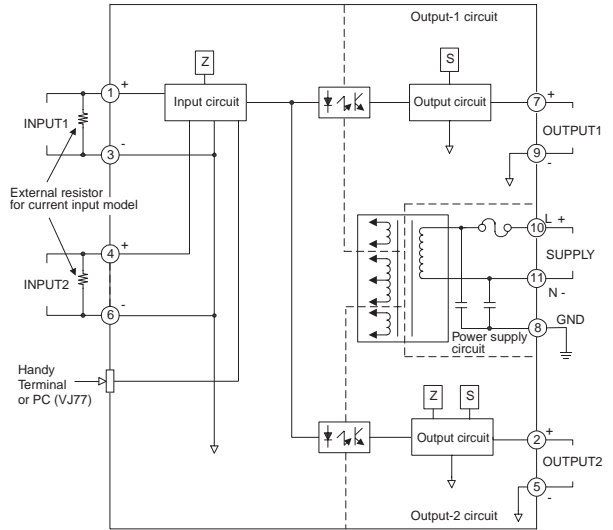

Note: Single-output models do not contain the output-2 circuit.

F04.EPS

External Dimensions

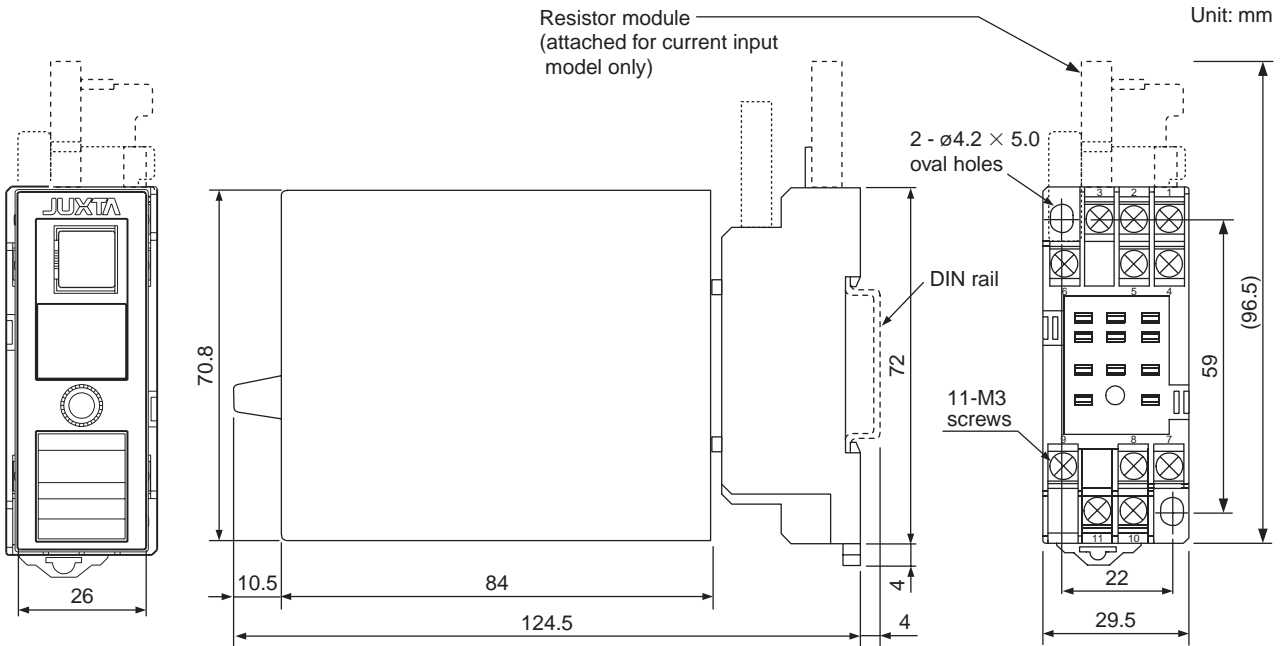

F05.EPS

• The information covered in this document is subject to change without notice for reasons of improvements in quality and/or performance.