

**digitalYEWFLO Series
Vortex Flowmeter
[Style:S2]**

IM 01F06A00-01EN

digitalYEWFO Series

Vortex Flowmeter

IM 01F06A00-01EN 21th Edition

Contents

| | | |
|-----------|---|------------|
| 1. | INTRODUCTION..... | 1-1 |
| 1.1 | Using This Instrument Safely | 1-2 |
| 1.2 | Warranty..... | 1-3 |
| 2. | HANDLING PRECAUTIONS..... | 2-1 |
| 2.1 | Checking Model and Specifications | 2-1 |
| 2.2 | Transportation and Storage Precautions..... | 2-1 |
| 3. | INSTALLATION | 3-1 |
| 3.1 | Installation Precautions | 3-1 |
| 3.2 | Piping Precautions | 3-1 |
| 3.3 | Maintenance of Piping..... | 3-5 |
| 3.4 | Cryogenic and High Process Temperature Version Insulation | 3-6 |
| 3.5 | Mounting Procedures..... | 3-6 |
| 4. | WIRING | 4-1 |
| 4.1 | Load Resistance of Output Condition | 4-1 |
| 4.2 | Selection of Wires | 4-2 |
| 4.3 | Connection | 4-2 |
| 4.4 | Connection of DYC Remote Type Signal Cable..... | 4-5 |
| 4.5 | End Processing Method of DYC Remote Type Signal Cable | 4-6 |
| 4.5.1 | For Remote Type Vortex Flowmeter (DY-N)..... | 4-6 |
| 4.5.2 | For Remote Type Vortex Flow Converter (DYA)..... | 4-7 |
| 4.6 | Wiring Procedures and Precautions..... | 4-8 |
| 4.7 | Grounding..... | 4-9 |
| 5. | BASIC OPERATING PROCEDURES..... | 5-1 |
| 5.1 | Display Configuration | 5-1 |
| 5.2 | Display Contents..... | 5-2 |
| 5.3 | Display Mode | 5-3 |
| 5.3.1 | Changes to Engineering Display Unit from % Display | 5-4 |
| 5.3.2 | Indicate the Total Rate in the Data Display(Lower)..... | 5-5 |
| 5.4 | Setting Mode..... | 5-6 |
| 5.4.1 | Display Configuration of Setting Mode | 5-6 |
| 5.4.2 | Data Setting Method | 5-7 |

| | | |
|-----------|--|------------|
| 6. | PARAMETERS | 6-1 |
| 6.1 | digitalYEWFO Parameters | 6-1 |
| 6.2 | Multi-Variable Type (/MV) Parameters..... | 6-1 |
| 6.3 | Parameters List | 6-1 |
| 6.4 | Parameters Description | 6-11 |
| 6.5 | Self-Diagnostic (Error Code List) | 6-20 |
| 7. | OPERATION FOR THE BRAIN TERMINAL (BT200) | 7-1 |
| 7.1 | Connection Method for the BT200 | 7-1 |
| 7.2 | BT200 Screen and Displaying Flow Rate | 7-2 |
| 7.3 | Setting Parameters using BT200 | 7-4 |
| 8. | OPERATION VIA HART CONFIGURATION TOOL (HART 5)..... | 8-1 |
| 8.1 | HART Protocol Revision | 8-1 |
| 8.2 | HART Configuration Tool and Matching of Device Revision | 8-1 |
| 8.3 | Setting Parameters using DTM | 8-2 |
| 8.4 | Interconnection between digitalYEWFO and HART Configuration Tool..... | 8-2 |
| 8.5 | Basic Setup..... | 8-3 |
| 8.6 | Parameter Setting | 8-3 |
| 8.7 | Data Renewing and Upload/Download function | 8-3 |
| 8.8 | Self-Diagnostic..... | 8-3 |
| 8.9 | Software Write Protect | 8-3 |
| 8.10 | Specific Functions of HART Configuration Tool | 8-4 |
| 8.10.1 | Burst Mode..... | 8-4 |
| 8.10.2 | Multidrop Mode | 8-4 |
| 8.10.3 | Switching HART Protocol Revision | 8-4 |
| 8.10.4 | Other Operations for the HART Configuration Tool | 8-5 |
| 8.11 | Menu Tree (HART 5)..... | 8-6 |
| 9. | OPERATION VIA HART CONFIGURATION TOOL (HART 7)..... | 9-1 |
| 9.1 | HART Protocol Revision | 9-1 |
| 9.2 | HART Configuration Tool and Matching of Device Revision | 9-1 |
| 9.3 | Setting Parameters using DTM | 9-1 |
| 9.4 | Interconnection between digitalYEWFO and HART Configuration Tool..... | 9-2 |
| 9.5 | Basic Setup..... | 9-3 |
| 9.6 | Parameter Setting | 9-3 |
| 9.7 | Data Renewing and Upload/Download function | 9-3 |
| 9.8 | Self-Diagnostic..... | 9-3 |
| 9.9 | Software Write Protect | 9-4 |
| 9.10 | Specific Functions of HART Configuration Tool | 9-4 |
| 9.10.1 | Process Variable Setup (Dynamic Variables)..... | 9-4 |
| 9.10.2 | Burst Mode..... | 9-5 |
| 9.10.3 | Event Notification | 9-8 |

| | | |
|-------------|---|--------------|
| 9.10.4 | Multidrop Mode | 9-9 |
| 9.10.5 | Loop Test, Simulation, and Squawk..... | 9-10 |
| 9.10.6 | Switching HART Protocol Revision | 9-13 |
| 9.10.7 | Other Operations for the HART Configuration Tool | 9-14 |
| 9.11 | Menu Tree (HART 7)..... | 9-15 |
| 10. | OPERATION | 10-1 |
| 10.1 | Adjustment | 10-1 |
| 10.1.1 | Zero Adjustment..... | 10-1 |
| 10.1.2 | Span Adjustment..... | 10-1 |
| 10.1.3 | Loop Test..... | 10-1 |
| 10.1.4 | Totalizer Start and Totalizer Reset | 10-2 |
| 10.1.5 | Setting of Pulse Output (Scaling)..... | 10-2 |
| 10.1.6 | Setting of Burnout Switch..... | 10-2 |
| 10.1.7 | Setting of Write Protect Switch | 10-3 |
| 10.1.8 | Power Failure | 10-3 |
| 10.2 | Adjustment for Manual Mode | 10-3 |
| 10.2.1 | Low Cut Adjustment..... | 10-3 |
| 10.2.2 | Zero Tuning..... | 10-3 |
| 11. | MAINTENANCE..... | 11-1 |
| 11.1 | Changing the Converter and the Terminal Box Orientation..... | 11-2 |
| 11.2 | Indicator Removal and Rotation..... | 11-3 |
| 11.3 | Amplifier Unit Removal | 11-3 |
| 11.4 | Amplifier Unit Assembling..... | 11-3 |
| 11.5 | Vortex Shedder Removal | 11-4 |
| 11.6 | Flow Calculation | 11-6 |
| 12. | TROUBLESHOOTING | 12-1 |
| 12.1 | Large Errors or Unstable Output..... | 12-1 |
| 12.2 | The Indication Goes to Zero at Certain Time | 12-1 |
| 12.3 | No Output When The Fluid is Flowing..... | 12-2 |
| 12.4 | Output is Indicated at Zero Flow | 12-3 |
| 12.5 | Multi-Variable Type (/MV)..... | 12-4 |
| 13. | GENERAL SPECIFICATIONS | 13-1 |
| 13.1 | Standard Specifications..... | 13-1 |
| 13.2 | Model And Suffix Codes..... | 13-5 |
| 13.3 | Option Specifications..... | 13-8 |
| 13.3.1 | Option Multi-Variable (Built-In Temperature Sensor) Type (/MV) | 13-10 |
| 13.3.2 | Option Reduced Bore Type (/R1, /R2)..... | 13-11 |
| 13.4 | Sizing..... | 13-11 |
| 13.5 | Detailed Accuracy | 13-13 |
| 13.6 | Option Specifications (For Explosion Protected Type)..... | 13-20 |
| 13.7 | External Dimensions | 13-22 |

| | | |
|------------|--|-------------|
| 14. | EXPLOSION PROTECTED TYPE INSTRUMENT | 14-1 |
| 14.1 | ATEX | 14-1 |
| 14.2 | FM | 14-4 |
| 14.3 | IECEX | 14-8 |
| 14.4 | CSA | 14-11 |
| 14.5 | TIIS | 14-14 |
| 15. | PED (PRESSURE EQUIPMENT DIRECTIVE) | 15-1 |

**INSTALLATION AND OPERATING PRECAUTIONS FOR FLAMEPROOF
ENCLOSURE “d” CERTIFIED UNDER JAPANESE TYPE CERTIFICATION**

Revision Information

1. INTRODUCTION

Thank you for purchasing the digitalYEWFLO series vortex flowmeter.

To ensure correct use of the instrument, please read this manual thoroughly and fully understand how to operate the instrument before operating it.

■ Regarding This Manual

- This manual should be provided to the end user.
- The contents of this manual may be changed without prior notice.
- All rights are reserved. No part of this manual may be reproduced in any form without Yokogawa's written permission.
- Yokogawa makes no warranty of any kind with regard to this material, including, but not limited to, implied warranties of merchantability and suitability for a particular purpose.
- All reasonable effort has been made to ensure the accuracy of the contents of this manual. However, if any errors or omissions are found, please inform Yokogawa.
- The specifications covered by this manual are limited to those for the standard type under the specified model number break-down and do not cover custom-made instruments.
- Please note that this manual may not be revised for any specification changes, construction changes or operating part changes that are not considered to affect function or performance.
- Yokogawa assumes no responsibilities for this product except as stated in the warranty.
- If the customer or any third party is harmed by the use of this product, Yokogawa assumes no responsibility for any such harm owing to any defects in the product which were not predictable, or for any indirect damages.

■ Safety and Modification Precautions

- The following general safety precautions must be observed during all phases of operation, service, and repair of this instrument. Failure to comply with these precautions or with specific WARNINGS given elsewhere in this manual violates safety standards of design, manufacture, and intended use of the instrument. Yokogawa assumes no liability for the customer's failure to comply with these requirements. If this instrument is used in a manner not specified in this manual, the protection provided by this instrument may be impaired.
- Yokogawa will not be liable for malfunctions or damage resulting from any modification made to this instrument by the customer.
- The following safety symbol marks are used in this manual and instrument.



WARNING

A WARNING sign denotes a hazard. It calls attention to procedure, practice, condition or the like, which, if not correctly performed or adhered to, could result in injury or death of personnel.



CAUTION

A CAUTION sign denotes a hazard. It calls attention to procedure, practice, condition or the like, which, if not correctly performed or adhered to, could result in damage to or destruction of the product.



IMPORTANT

An IMPORTANT sign denotes that attention is required to avoid damage to the instrument or system failure.



NOTE

A NOTE sign denotes information necessary for essential understanding of operation and features.

1.1 Using This Instrument Safely

(1) Installation



WARNING

- Installation of the vortex flowmeter must be performed by expert engineer or skilled personnel. No operator shall be permitted to perform procedures relating to installation.
- The vortex flowmeter must be installed within the specification conditions.
- The vortex flowmeter is a heavy instrument. Be careful that no damage is caused to personnel through accidentally dropping it, or by exerting excessive force on the vortex flowmeter. When moving the vortex flowmeter, always use a trolley and have at least two people carry it.
- When the vortex flowmeter is processing hot fluids, the instrument itself may become extremely hot. Take sufficient care not to get burnt.
- Where the fluid being processed is a toxic substance, avoid contact with the fluid and avoid inhaling any residual gas, even after the instrument has been taken off the piping line for maintenance and so forth.
- Do not apply excessive weight, for example, a person stepping on the vortex flowmeter.
- Do not open the cover in wet weather or humid environment. When the cover is open, stated enclosure protection is not applicable.
- Before opening the cover, turn off the power and wait for more than 2 minutes.
- All procedures relating to installation must comply with the electrical code of the country where it is used.

(2) Wiring



WARNING

- The wiring of the vortex flowmeter must be performed by expert engineer or skilled personnel. No operator shall be permitted to perform procedures relating to wiring.
- When connecting the wiring, check that the supply voltage is within the range of the voltage specified for this instrument before connecting the power cable. In addition, check that no voltage is applied to the power cable before connecting the wiring.

(3) Operation



WARNING

- Do not open the cover in wet weather or humid environment. When the cover is open, stated enclosure protection is not applicable.
- Before opening the cover, turn off the power and wait for more than 2 minutes.

(4) Maintenance



WARNING

- Maintenance of the vortex flowmeter should be performed by the trained personnel having knowledge of safety standard. No operator shall be permitted to perform any operations relating to maintenance.
- Do not open the cover in wet weather or humid environment. When the cover is open, stated enclosure protection is not applicable.
- Before opening the cover, turn off the power and wait for more than 2 minutes.
- Always conform to maintenance procedures outlined in this manual. If necessary, contact Yokogawa.

(5) Explosion Protected Type Instrument



WARNING

- The instruments are products which have been certified as explosion protected type instruments. Strict limitations are applied to the structures, installation locations, external wiring work, maintenance and repairs, etc. of these instruments. Sufficient care must be taken, as any violation of the limitations may cause dangerous situations. Be sure to read Chapter 14 “EXPLOSION PROTECTED TYPE INSTRUMENT” before handling the instruments. For TIIS flameproof type instruments, be sure to read “INSTALLATION AND OPERATING PRECAUTIONS FOR TIIS FLAMEPROOF EQUIPMENT” at the end of this manual.
- Only trained persons use this instrument in the industrial location.
- Take care not to generate mechanical spark when access to the instrument and peripheral devices in hazardous locations.

(6) European Pressure Equipment Directive (PED)



WARNING

- When using the instrument in compliance with PED, be sure to read Chapter 15 “PED (PRESSURE EQUIPMENT DIRECTIVE)” before use.

1.2 Warranty

- The terms of this instrument that are guaranteed are described in the quotation. We will make any repairs that may become necessary during the guaranteed term free of charge.
- Please contact our sales office if this instrument requires repair.
- If the instrument is faulty, contact us with concrete details about the problem and the length of time it has been faulty, and state the model and serial number. We would appreciate the inclusion of drawings or additional information.
- The results of our examination will determine whether the meter will be repaired free of charge or on an at-cost basis.

■ The guarantee will not apply in the following cases:

- Damage due to negligence or insufficient maintenance on the part of the customer.
- Problems or damage resulting from handling, operation or storage that violates the intended use and specifications.
- Problems that result from using or performing maintenance on the instrument in a location that does not comply with the installation location specified by Yokogawa.
- Problems or damage resulting from repairs or modifications not performed by Yokogawa or someone authorized by Yokogawa.
- Problems or damage resulting from inappropriate reinstallation after delivery.
- Problems or damage resulting from disasters such as fires, earthquakes, storms, floods, or lightning strikes and external causes.

■ Trademarks:

- ‘digitalYEWFLO’, ‘DY’, ‘DYA’, ‘DYC’, and ‘BRAIN TERMINAL’ are registered trademarks of Yokogawa Electric Corporation. Company names and product names used in this material are registered trademarks or trademarks of their respective owners.
- In this manual, trademarks or registered trademarks are not marked with TM or ®.

2. HANDLING PRECAUTIONS

digitalYEWFLO Series Vortex Flowmeters are thoroughly tested at the factory before shipment. When these instruments are delivered, perform a visual check to ascertain that no damage occurred during shipment.

This section describes important cautions in handling these instruments. Read carefully before using them.

If you have any problems or questions, contact your nearest YOKOGAWA service center or sales representative.

2.1 Checking Model and Specifications

The model and important specifications are indicated on the name plate attached to the case. Verify that they are the same as those specified in the original order, read Chapter 13 "GENERAL SPECIFICATIONS ." In any correspondence, always give model (MODEL) and serial number (NO.) from the name plate.

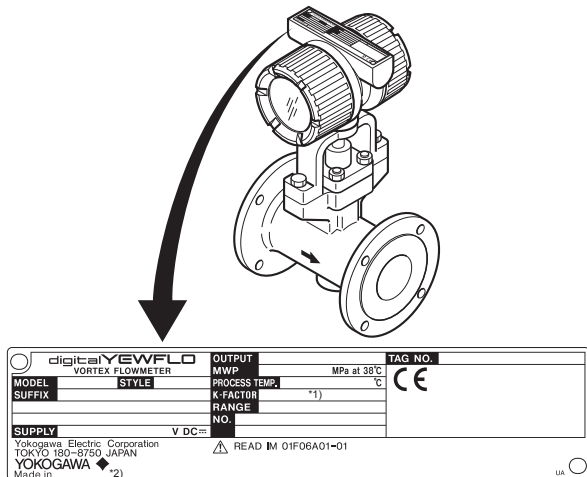

F0201.ai

Figure 2.1(a) Example of Name Plate for Integral Type

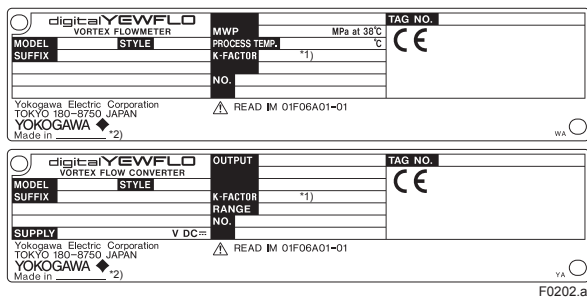

F0202.ai

Figure 2.1(b) Example of Name Plate for Remote Type

*1): K factor at + 15°C

*2): The product - producing country.

2.2 Transportation and Storage Precautions

If the instrument is to be stored for a long period of time after delivery, observe the following points.

- (1) The instrument should be stored in its original packing condition in the storage location.
- (2) Select a storage location that fulfils the following conditions:

- A place where it will not be exposed to rain or water
- A place subject to minimal vibrations or shocks
- Temperature and humidity levels should be as follows:

Temperature: -40 to +80°C

Humidity: 5 to 100% RH (no condensation)

The preferred ambient temperature and humidity levels are +25°C and approximately 65% RH.

- (3) If the digitalYEWFLO vortex flowmeter is transferred to the installation site and stored without being installed, its performance may be impaired due to the infiltration of rainwater and so forth. Be sure to install and wire the digitalYEWFLO vortex flowmeter as soon as possible after transferring it to the installation location.
- (4) The vortex flowmeter is a heavy instrument. Be careful that no damage is caused to personnel through accidentally dropping it, or by exerting excessive force on the vortex flowmeter. When moving the vortex flowmeter, always use a trolley and have at least two people carry it.

3. INSTALLATION

! WARNING

This instrument must be installed by expert engineer or skilled personnel. The procedures described in this chapter are not permitted for operators.

3.1 Installation Precautions

(1) Ambient Temperature

Avoid an area which has wide temperature variations. When the installation area is subjected to heat radiation from process plant, ensure adequate heat prevention or ventilation.

(2) Atmospheric Conditions

Avoid installing the vortex flowmeter in a corrosive atmosphere. When the vortex flowmeter must be installed in a corrosive atmosphere, adequate ventilation must be provided

(3) Mechanical Shock or Vibration

The vortex flowmeter is of sturdy construction, but select an area subject to minimize mechanical vibration or impact shock. If the flowmeter is subject to vibrations, it is recommended that pipeline supports to be provided as shown in Figure 3.1.

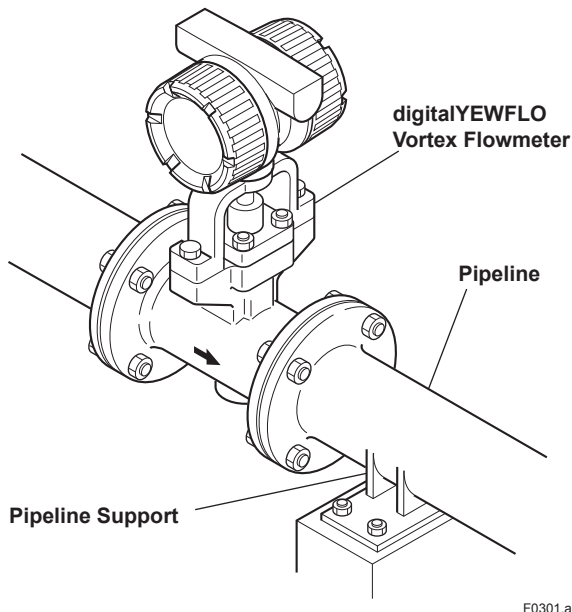

Figure 3.1 Example of Pipeline Support

F0301.ai

(4) Precautions Regarding Piping

- (a) Ensure that the process connector bolts are tightened firmly.
- (b) Ensure that no leak exists in the process connection pipeline.
- (c) Do not apply a pressure higher than the specified maximum working pressure.
- (d) Do not loosen or tighten the flange mounting bolts when the assembly is pressurized.
- (e) Handle the vortex flowmeter carefully when measuring dangerous liquids, so that the liquids do not splash into eyes or on face. When using dangerous gases, be careful not to inhale them.

(5) Other Considerations

- Choose a location where is sufficient clearance around digitalYEWFLO exist to allow such work as routine inspections.
- Choose a location that ensures easy wiring and piping.

3.2 Piping Precautions

■ Straight Pipe Length and Recommendations

Read Table 3.1 about Valve Position and Straight Pipe Length and so on.

● Piping support

Typical vibration immunity level is 1G for normal piping condition. Piping support should be fixed in case of over 1G vibration level.

● Installation direction

If a pipe is always filled with liquids, the pipe can be installed vertically or at inclined angle.

● Adjacent pipes

The process pipeline inner diameter should be larger than the digitalYEWFLO inner diameter.

Use the following adjacent pipe.

| Model Code | Adjacent Pipe |
|---|--|
| DY015 up to DY050 DY025/R1 up to DY080/R1 DY040/R2 up to DY100/R2 | Sch40 or larger inner diameter than Sch40 |
| DY080 up to DY400 DY100/R1 up to DY200/R1 DY150/R2 up to DY200/R2 | Sch80 or larger inner diameter than Sch80 |
| DY025/R1 up to DY150/R1 Process connection code: BA6, CA6 | Sch160 or larger inner diameter than Sch160 |

● Piping Condition

In case the piping conditions are compounded, install on the straight pipe section where the upstream part is sufficiently rectified.

Table 3.1 (a) Straight pipe length and recommendations (1)

D: Nominal diameter (mm)

| Description | Figure |
|---|--------|
| <p>Reducer pipe: Ensure the upstream straight pipe length to be 5D or more, and the downstream straight pipe length to be 5D or more for per reducer pipe.</p> | |
| <p>Expander pipe: Ensure the upstream straight pipe length to be 10D or more, and the downstream straight pipe length to be 5D or more for per expander pipe.</p> | |
| <p>Bent pipe and straight pipe length:</p> <ol style="list-style-type: none"> 1. Single bent pipe 2. Double bent pipe; coplanar 3. Double bent pipe; non coplanar | |
| <p>Valve position and straight pipe length:</p> <ul style="list-style-type: none"> ■ Install the valve on the downstream side of the flowmeter. The upstream straight pipe length dependent on the element located on the upstream such as reducer/expander, bent and etc., read description as above. Keep 5D or more for downstream straight pipe length. ■ In case the valve has to be installed on the upstream of the flowmeter, ensure the upstream straight pipe length to be 20D or more, and the downstream straight pipe length be 5D or more. | |

Table 3.1 (b) Straight pipe length and recommendations (2)

D: Nominal diameter (mm)

| Description | Figure |
|--|--------|
| <p>Fluid vibration: For a gas line which uses a position-type or roots-type blower compressor or a high-pressure liquid line (about 1MPa or more) which uses piston-type or plunger-type pump, fluid vibrations may be produced. In these case, install valve on the upstream side of digitalYEWFLO. For inevitable fluid vibration, put a vibration damping device such as throttling plate or expansion section in the upstream side of digitalYEWFLO.</p> | |
| <p>Piston-type or plunger pump: Install the accumulator on the upstream side of digitalYEWFLO to reduce fluid vibrations.</p> | |
| <p>Valve positon (T-type piping exist): When pulsation causes by a T-type piping exist, install the valve on the upstream of the flowmeter. Example: As shown in the figure, when the valve V1 is turned off, the fluid flow throught B as to meter A the flow is zero. But due to the pulsating pressure is detected, the meter is zero point become fluctuating. To avoid this, change the valve V1 location to V1'.</p> <p>Note: In case of the Reduced Bore Type, moisture may be remained upstream of the flowmeter. Drain it appropriately.</p> | |
| <p>Pressure and Temperature Taps: When the temperature/pressure correction, place a pressure tap in a position on the downstream side 2 to 7D from digitalYEWFLO. Then place a temperature tap in a position on the downstream side 1 to 2D from a pressure tap.</p> <p>When use a temperature tap only, place it in a position on the downstream side 3 to 9D from digitalYEWFLO.</p> | |
| <p>Mounting Gasket: Avoid mounting gaskets which protrude into the pipe line. This may cause inaccurate readings. Use the gaskets with bolt holes, even if digitalYEWFLO is the wafer type. When using a spiral gasket (without bolt holes), confirm the size with the gasket -manufacturer, as standard items may not be used for certain flange ratings.</p> | |

Table 3.1 (c) Straight pipe length and recommendations (3)

| Description | Figure |
|--|--------|
| <p>Heat-Insulation: When an integral-type flowmeter or a remote type detector is installed and the pipe carrying high-temperature fluids is heat-insulated, do not wrap adiabatic materials around the installation the bracket (DY015 to DY100) or the nozzle (DY150 to DY400) of the converter.</p> <p>Note: Read Section 3.4 "Cryogenic and High Process Temperature Version Insulation" and install it rightly.</p> | |
| <p>Flushing of the pipe line: Flush and clean scale, incrustation and sludge on the inside of pipe for newly installed pipe line and repaired pipe line before the operation. For flushing, the flow should flow through bypass-piping to avoid damaging the flowmeter. If there is no bypass-piping, install short pipe instead of the flowmeter.</p> | |

■ Mounting Precautions



In case of high process temperature, care should be taken not to burn yourself because the surface of body and case reach a high temperature.

(1) Gas or Steam Measuring Precautions

- Piping to Prevent Standing Liquid
Mount digitalYEWFLO in a vertical pipeline to avoid liquid traps. When digitalYEWFLO is installed horizontally, raise that part of the pipeline in which the digitalYEWFLO is installed.

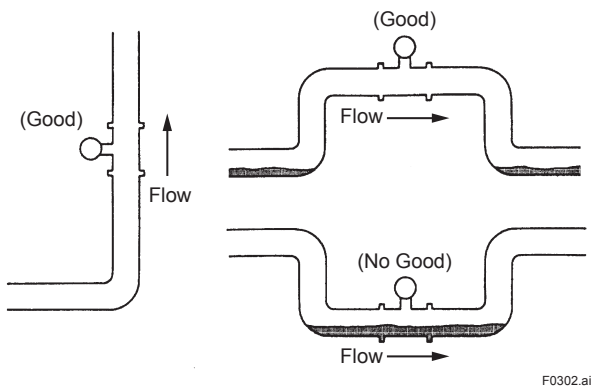

F0302.ai

(2) Liquid Measurement Precautions

To insure accurate measurement, the digitalYEWFLO must always have a full pipe.

- Piping Requirements for Proper Operation
Allow the flow to flow against gravity. When the flow is moving with gravity, lift the downstream pipe length above the digitalYEWFLO installation level to maintain full pipeline.

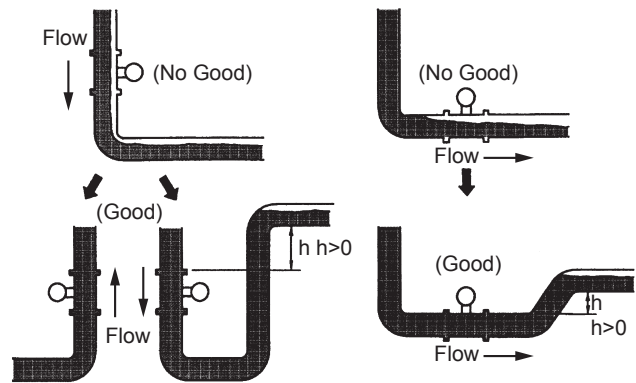

F0303.ai

• Piping for Avoiding Bubbles

Flows containing both gas and liquid cause problems. Avoid gas bubbles in a liquid flow. Piping should be carried out to avoid bubble generation.

Install the valve on the downstream side of the flowmeter because pressure drop across the control valve may cause gas to come out of the solution.

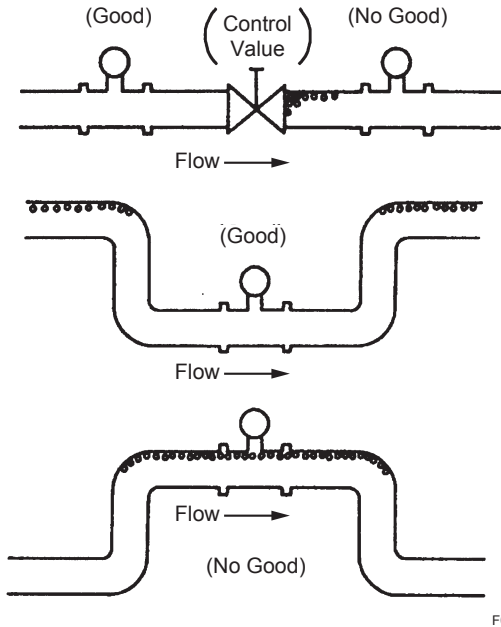

F0304.ai

(3) Multi-Phase Flow

digitalYEWFlo can measure gas, liquid and steam when there is no change in state. However, accurate measurement of mixed flows (e.g. gas and liquid) is not possible.

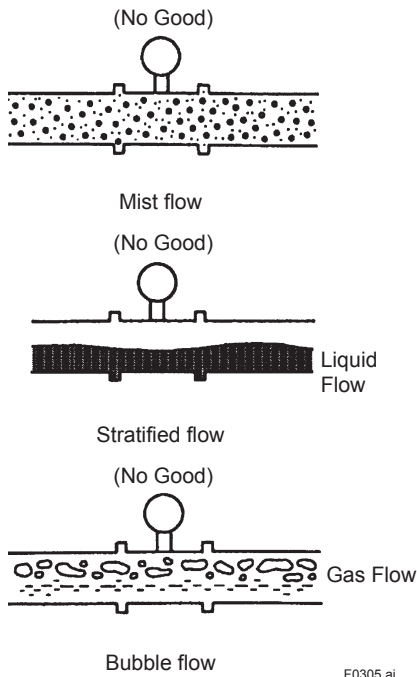

F0305.ai

(4) Pipeline Diameter and digitalYEWFlo

The process pipeline inner diameter should be slightly larger than the vortex flowmeter inner diameter, schedule 40 or lower pipe should be used for 1/2 to 2 inch flowmeters and schedule 80 or lower pipes for 3 to 16 inch flowmeters.

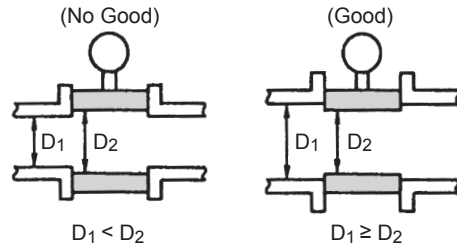

F0306.ai

(5) Waterproof Construction

The vortex flowmeter is of IP67, Type 4X, JIS C 0920 watertight protection. However, it cannot be used under water.

3.3 Maintenance of Piping

(1) Pipe cleaning

- Flushing of pipe line (Cleaning)
Flush and clean scale, incrustation and sludge on the inside of pipe wall for newly installed pipe line and repaired pipe line before the operation.
- Fluid Carrying Solids
Do not measure fluids that carry solids (e.g. sand and pebbles). Make sure users periodically remove solids adhering to the vortex shedder.
- Obstruction of flow fluids may cause to make a chemical reaction and the fluid will be crystallized and hardened, and be deposited on the pipe wall and shedder bar.
In those cases, clean shedder bar.

(2) Bypass piping

Bypass piping is convenient for the maintenance of digitalYEWFlo (vortex shedder cleaning, etc.).

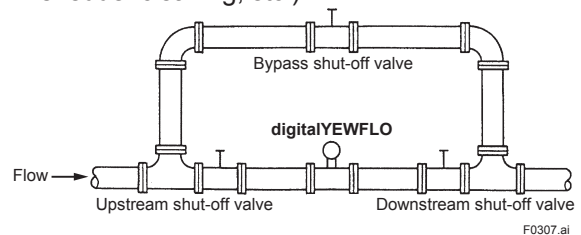

F0307.ai

3.4 Cryogenic and High Process Temperature Version Insulation

When you are using Cryogenic and High Process Temperature version of digitalYEWFLOW Vortex Flowmeter (Option code: /HT, /LT), read following contents.

■ Installing Cryogenic Version

For cryogenic applications, use stainless steel mounting bolts and nuts to install the flowmeter. These can be ordered separately from YOKOGAWA. Cover the flowmeter body with heat insulating material so that the flowmeter can be maintained at ultra-low temperatures.

■ Maintenance for Cryogenic Applications

Option code: /LT uses special materials that produce vortex flowmeter for cryogenic applications. When you are replacing a shedder bar, specify Cryogenic Version shedder bar. To avoid condensing in the terminal box, ensure that the wire connecting port is well sealed.

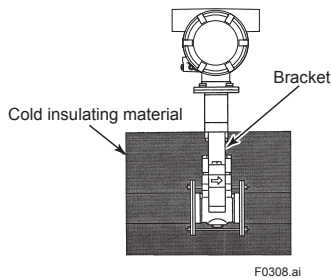

■ Installing High Process Temperature Version

Installation of the flowmeter is the same as the standard type. Cover the flowmeter body with heat insulating material following instruction of "CAUTION".

CAUTION

Keep the upper limit of heat insulating material to prevent overheating of the terminal box. Seal the Heat-Insulator to avoid hot-air leakage.

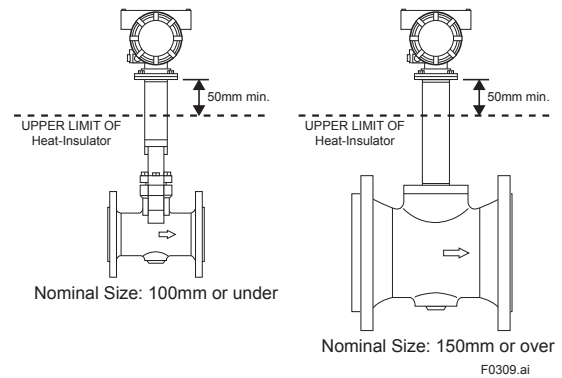

■ Maintenance for High Process Temperature Applications

Option code: /HT uses special materials that produce vortex flowmeter for High Process Temperature applications. When you are replacing a shedder bar or a gasket, specify High Process Temperature Version.

3.5 Mounting Procedures

WARNING

The Vortex Flowmeter is a heavy instrument. Please be careful to prevent persons from injuring when it is handled.

Before installing the instrument verify the following. The direction of flow should match to the arrow mark on the instrument body. When changing the orientation of the terminal box, read Chapter 11 "MAINTENANCE."

1. Installation of Vortex flowmeter of the wafer and flange type is shown in Table 3.3. When installing the wafer type vortex flowmeter, it is important to align the instrument bore with the inner diameter of the adjacent piping. To establish alignment, use the four collars supplied with the instrument.

- Four collars are supplied for 1/2 inch (15mm) to 1- 1/2inch (40mm), 2 inch of JIS 10K or ANSI class 150, and 3 inch of ANSI class 150. Install the instrument as illustrated in Table 3.3.
- If the adjacent flanges have eight bolt holes, insert the stud bolts in the holes on the instrument shoulder.
- Stainless steel stud bolts and nuts are available on order. When they are to be supplied by the user, read Table 3.2 for stud bolt length. Gaskets must be supplied by the user.

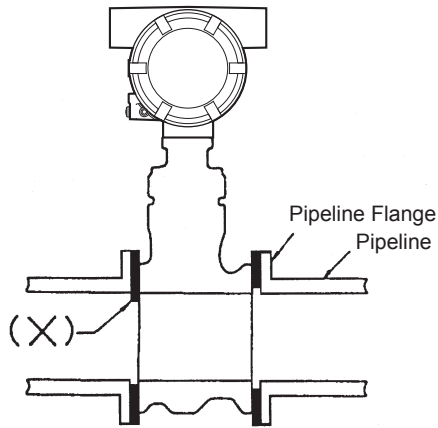

2. Avoid mounting gaskets which protrude into the pipeline. This may cause inaccurate readings. Use gaskets with bolt holes, even if digitalYEWFL0 is of the wafer type. When using a spiral gasket (without bolt holes), confirm the size with the gasket-manufacturer, as standard items may not be used for certain flange ratings.

Table 3.2 Flange Rating

| Size mm (inch) | Flange Rating | Major Diameter of External Thread of Stud Bolt d (mm) | Length ℓ (mm) |
|----------------|--|---|---------------|
| 15mm (1/2B) | JIS 10K, 20K/DIN 10, 16,25,40 | 12 | 160 |
| | JIS 40K | 16 | 160 |
| | ANSI 150, 300, 600 | 12.7 | 155 |
| 25mm (1B) | JIS 10K, 20K, 40K | 16 | 160 |
| | ANSI 150 | 12.7 | 155 |
| | ANSI 300, 600 | 15.9 | 160 |
| | DIN 10, 16, 25, 40 | 12 | 160 |
| 40mm (1-1/2B) | JIS 10K, 20K/DIN 10, 16, 25, 40 | 16 | 160 |
| | JIS 40K | 20 | 170 |
| | ANSI 150 | 12.7 | 155 |
| | ANSI 300, 600 | 19.1 | 170 |
| 50mm (2B) | JIS 10K, 20K, 40K/ DIN 10, 16, 25, 40 ANSI 150, 300, 600 | 16 | 200 |
| | | 15.9 | 200 |
| 80mm (3B) | JIS 10K/DIN 10, 16, 25, 40 | 16 | 220 |
| | JIS 20K, 40K | 20 | 240 |
| | ANSI 150 | 15.9 | 240 |
| | ANSI 300, 600 | 19.1 | 240 |
| 100mm (4B) | JIS 10K/DIN 10, 16 | 16 | 220 |
| | JIS 20K/DIN 25, 40 | 20 | 240 |
| | JIS 40K | 22 | 270 |
| | ANSI 150 | 15.9 | 240 |
| | ANSI 300 | 19.1 | 240 |
| | ANSI 600 | 22.2 | 270 |

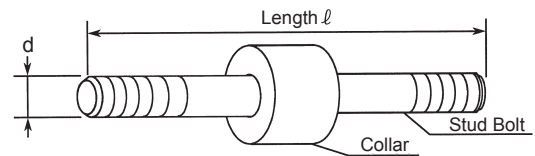
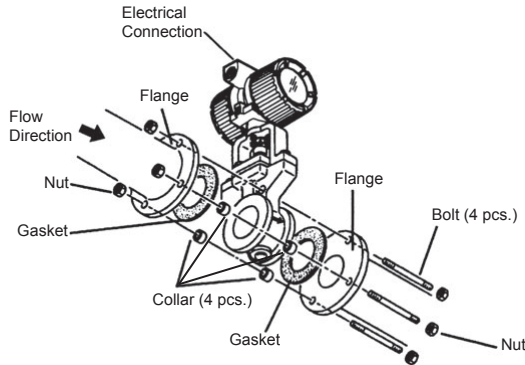
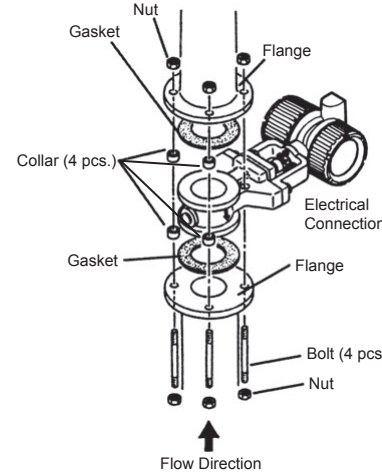
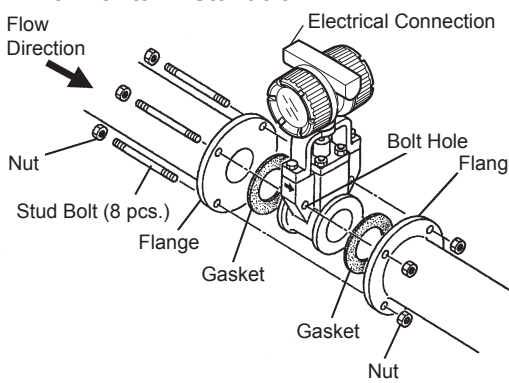
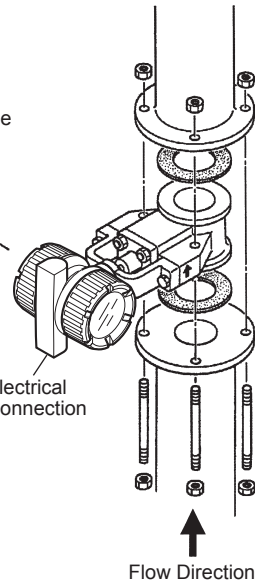
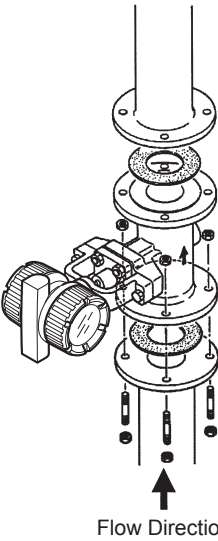
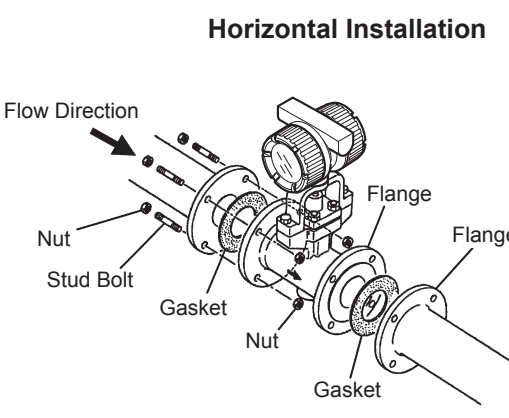

Table 3.3 (a) Installation of Wafer Type Vortex Flowmeter

| Wafer type | Description | | | | | | | | |
|---|--|---------------|----------------------------|------------------------------------|-------|--|--------|--|---|
| <p>When Installation Collar are required, the installation vortex flowmeters applied to the following line sizes and flange ratings.</p> <table border="1" data-bbox="181 405 606 584"> <thead> <tr> <th>Size mm (inch)</th> <th>Flange Rating</th> </tr> </thead> <tbody> <tr> <td>15 to 40 (1/2 to 1-1/2)</td> <td>All ratings</td> </tr> <tr> <td>50(2)</td> <td>JIS 10K, ANSI class 150, DIN PN10 to PN40</td> </tr> <tr> <td>80(3)</td> <td>ANSI class 150</td> </tr> </tbody> </table> <p>! WARNING The inside diameter of the gasket must be larger than the pipe inner diameter so that it will not disturb the flow in the pipeline.</p> <p>! WARNING When installing the Flowmeter vertically in the open air, change the electrical connection port direction to the ground. If the electrical connection port is installed upwards, rain water might leak in.</p> <p>! WARNING In case of vertical installation, two collars in the upper part might move after the installation. But it doesn't influence the performance, please use the flowmeter under such condition.</p> | Size mm (inch) | Flange Rating | 15 to 40 (1/2 to 1-1/2) | All ratings | 50(2) | JIS 10K, ANSI class 150, DIN PN10 to PN40 | 80(3) | ANSI class 150 | <p>Horizontal Installation</p>  <p>Vertical Installation</p>  <ol style="list-style-type: none"> (1) Insert two collars on each two bolts of bottom side of the flowmeter. (2) Fit the flowmeter body to the collars. And tighten the four bolts and nuts uniformly. (3) Check for leakage from the flange connections. |
| Size mm (inch) | Flange Rating | | | | | | | | |
| 15 to 40 (1/2 to 1-1/2) | All ratings | | | | | | | | |
| 50(2) | JIS 10K, ANSI class 150, DIN PN10 to PN40 | | | | | | | | |
| 80(3) | ANSI class 150 | | | | | | | | |
| <p>When Installation Collars are not required, the installation vortex flowmeters applied to the following line sizes and flanges.</p> <table border="1" data-bbox="181 1503 606 1682"> <thead> <tr> <th>Size mm (inch)</th> <th>Flange Rating</th> </tr> </thead> <tbody> <tr> <td>50(2)</td> <td>JIS 20K, 40K ANSI class 300,600</td> </tr> <tr> <td>80(3)</td> <td>JIS 10K, 20K, 40K ANSI class 300, 600</td> </tr> <tr> <td>100(4)</td> <td>JIS 10K, 20, 40K ANSI class 150, 300, 600</td> </tr> </tbody> </table> | Size mm (inch) | Flange Rating | 50(2) | JIS 20K, 40K ANSI class 300,600 | 80(3) | JIS 10K, 20K, 40K ANSI class 300, 600 | 100(4) | JIS 10K, 20, 40K ANSI class 150, 300, 600 | <p>Horizontal Installation</p>  <p>Vertical Installation</p>  <ol style="list-style-type: none"> (1) Insert two stud bolts in the bolt holes on the flowmeter shoulder to align the instrument body with the inner diameter of the adjacent piping. (2) Tighten all bolts uniformly and check that there is no leakage between the instrument and the flanges. |
| Size mm (inch) | Flange Rating | | | | | | | | |
| 50(2) | JIS 20K, 40K ANSI class 300,600 | | | | | | | | |
| 80(3) | JIS 10K, 20K, 40K ANSI class 300, 600 | | | | | | | | |
| 100(4) | JIS 10K, 20, 40K ANSI class 150, 300, 600 | | | | | | | | |

F0312.ai

Table 3.3 (b) Installation of Flange Type Vortex Flowmeter

| Flange type | Description |
|--|---|
| <p>Use the stud bolts and nuts supplied with the flowmeter of the user. The gaskets should be supplied by the user.</p> <p>CAUTION</p> <p>The inside diameter of the gasket must be larger than the pipe inner diameter so that it will not disturb the flow in the pipeline.</p> | <div style="display: flex; justify-content: space-around;"> <div style="text-align: center;">  <p>Vertical Installation</p> </div> <div style="text-align: center;">  <p>Horizontal Installation</p> </div> </div> |

F0313.ai

Table 3.3 (c) Installation of Remote Type Converter

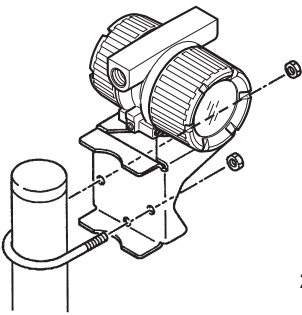
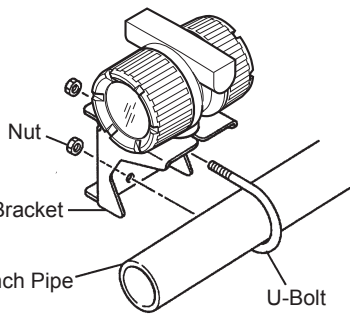
| Remote type converter | Description |
|---|--|
| <p>CAUTION</p> <p>A signal cable (DYC) is used between the remote type flowmeter and the converter. The maximum signal cable length is 97.5ft (30m).</p> | <p>The converter is mounted on a 2-inch (60.5mm outer dia.) stanchion or horizontal pipe. Do not mount the converter on a vertical pipe. It makes wiring and maintenance difficult. The converter mounting orientation can be changed as illustrated below.</p> <div style="display: flex; justify-content: space-around;"> <div style="text-align: center;">  <p>Stanchion Mounting</p> </div> <div style="text-align: center;">  <p>Horizontal Pipe Mounting</p> </div> </div> |

F0314.ai

4. WIRING



WARNING

The wiring of the vortex flowmeter must be performed by expert engineer or skilled personnel. No operator shall be permitted to perform procedures relating to wiring.



CAUTION

Once all wiring is complete, check the connections before applying power to the instrument. Improper arrangements or wiring may cause a unit malfunction or damage.

4.1 Load Resistance of Output Condition

Be sure to observe the following precautions when wiring:



CAUTION

- When the ambient temperature of the wire exceeds +60°C, use heat-resistant insulated wire with a maximum allowable temperature more than ambient temperature +30°C or above.
- Do not connect cables outdoors in wet weather in order to prevent damage from condensation and to protect the insulation.
- Do not splice the cable between the flowtube terminal and the converter if it is too short. Replace the short cable with a cable that is the appropriate length.
- All the cable ends must be provided with round crimp-on terminals and be securely wired.
- Be sure to turn power off before opening the cover.
- Before turning the power on, tighten the cover securely.
- Explosion protected types must be wired in accordance with specific requirement (and, in certain countries, legal regulations) in order to preserve the effectiveness of their explosion protected features.
- The terminal box cover is locked by the Locking Screw. In case of opening the terminal box cover, use the hexagonal wrench attached.
- Be sure to lock the cover by the Locking Screw using the hexagonal wrench attached after installing the cover.

Table 4.1 shows the connection method of several output conditions.

(1) Analog Output (4 to 20 mA DC)

This converter uses the same two wires for both, the signal and power supply. A DC power supply is required in a transmission loop. The total leadwire resistance including the instrument load and power distributor (supplied by the user) must conform to a value in the permissible load resistance range. Read Figure 4.1.

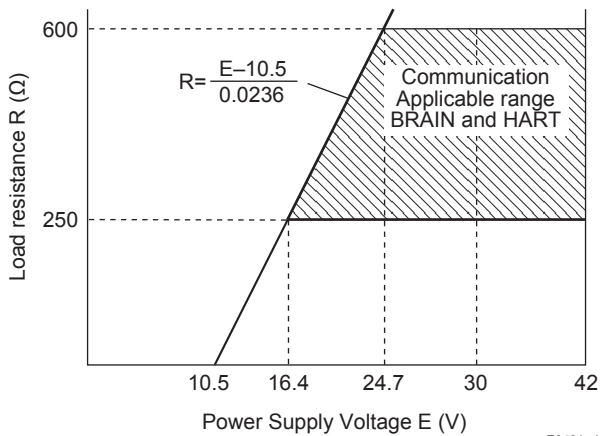

Figure 4.1 Relationship between Power Supply Voltage and Load Resistance (4 to 20 mA DC Output)

(2) Pulse output and Alarm, Status Output

This version uses three wires between the converter and the power supply. A DC power and load resistance are required, and pulse output is connected to a totalizer or an electric counter. Low level of the pulse output is 0 to 2V. No communication is possible over a transmission line. Communication via the amplifier board is always possible irrespective of the wiring condition.

(3) Simultaneous Analog-Pulse Output

When using digital YEW FLO in the simultaneous analog -pulse output mode, the communicable distance of the transmission line is restricted on the wiring method. Table 4.1 shows the examples of connection for this output mode. Communication via the amplifier board is always possible irrespective of the wiring condition.

IMPORTANT

For pulse output and the simultaneous analog-pulse output, use the load resistance. Read Table 4.1.

4.2 Selection of Wires

The following should be taken into consideration when selecting cables for use between the converter and distributor.

- (1) Use 600V PVC insulated wire or equivalent standard wire or cable.
- (2) Use shielded wire in areas susceptible to electrical noise (both analog and pulse output versions).
- (3) In areas with high or low ambient temperatures, use wires or cables suitable for such temperatures.
- (4) In atmospheres where oils or solvents, corrosive gases or liquids may be present, use suitable wires or cables.
- (5) Use cable which withstand temperature up to +60°C and more, when ambient temperature is more than +60°C.
- (6) The outer diameter of the screw for grounding terminal and the cable terminal is 4mm.
- (7) Recommend a crimping terminal with an insulating sleeve (for 4mm screw).

IMPORTANT

For the remote type, use DYC signal cable to connect the converter and remote type flowmeter(DY-N).

4.3 Connection

Table 4.1 shows the connection sample of connection for power supply and load resistance. The terminal position of each connection is shown in Figure 4.2.

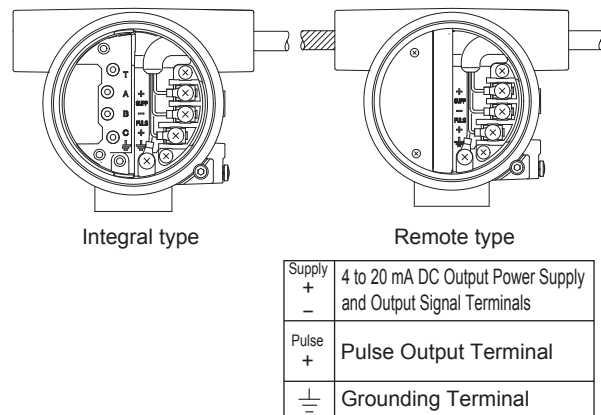
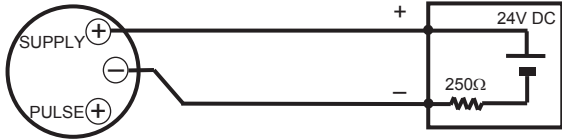
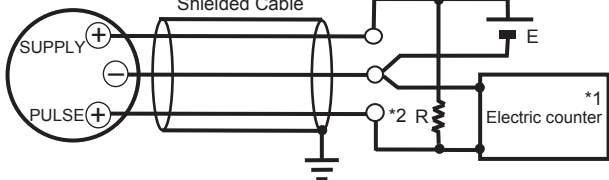
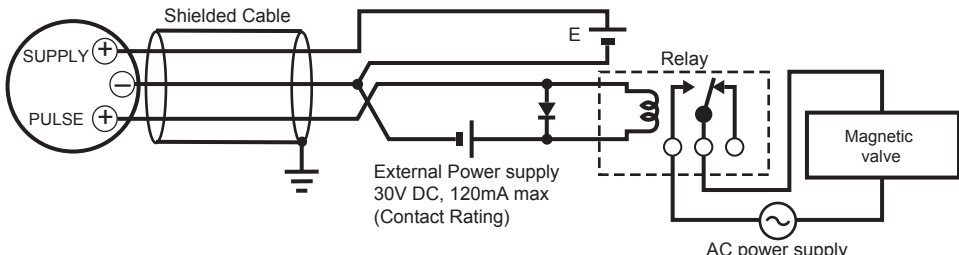

Figure 4.2 Terminal Position

Table 4.1 (a) The wiring example for the analog and pulse and status, alarm output.

| Connection | Description |
|--|---|
| <p>Analog Output</p> <p>In this case, Communication is possible (up to a distance of 2km when a CEV cable is used.)</p> | <p>digitalYEWFLO Electrical Terminal</p> <p>Distributor (or communication medium)</p>  |
| <p>Pulse Output</p> <p>In this case, No communication is possible.</p> | <p>digitalYEWFLO Electrical Terminal</p> <p>Shielded Cable</p> <p>Use the Three-wire shielded cable.</p> <p>This supply voltage requires a power source with a maximum output current of no less than $E/R+25mA$.</p>  |
| <p>Status Output Alarm Output</p> <p>In this case, No communication is possible.</p> | <p>digitalYEWFLO Electrical Terminal</p> <p>Shielded Cable</p> <p>Use the Three-wire shielded cable.</p> <p>External Power supply 30V DC, 120mA max (Contact Rating)</p> <p>Relay</p> <p>Magnetic valve</p> <p>AC power supply</p>  |

*1: To avoid the influence of external noise, use an electric counter which fits to the pulse frequency.

*2: Resistor is not necessary in case of an electric counter which can receive contact pulse signal directly.

4.4 Connection of DYC Remote Type Signal Cable

The DYC remote type signal cable is shown in Figure 4.3 and Figure 4.4, and the terminal is shown in Figure 4.5.

The maximum cable length is 30 m (97.5 feet).

Remove terminal box cover and wiring connection dust-cap before wiring.

For remote type converter has two electrical connections (cable inlets). Use the left connection as viewed from the terminal box for the DYC remote type signal cable and the right connection for the transmission cable.

If a signal cable kit is supplied by YOKOGAWA, both ends of the cable must be finished in accordance with the following instructions. Read Section 4.5 "End Processing Method of DYC Remote Type Signal Cable".



After completing the signal cable connections, install the shielded cover to signal cable terminal as shown in Figure 4.6.

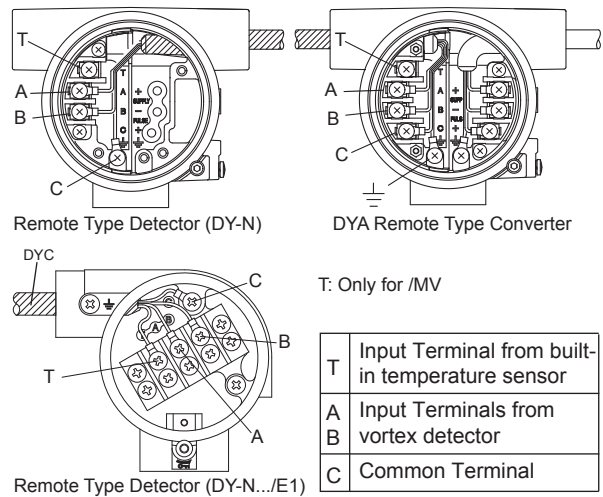

Figure 4.5 Terminal of Detector and Converter

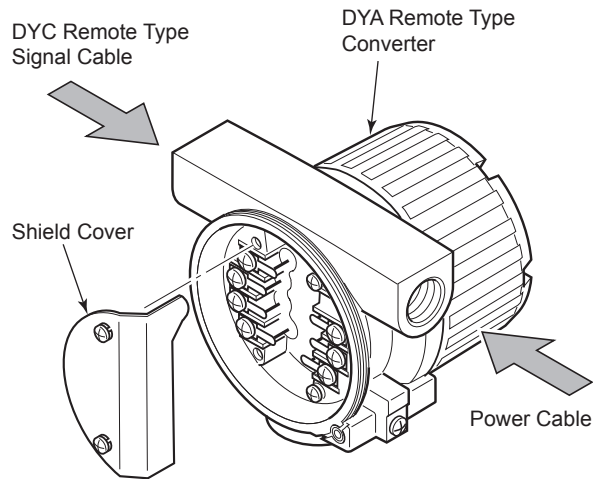

Figure 4.6 Shielded Cover

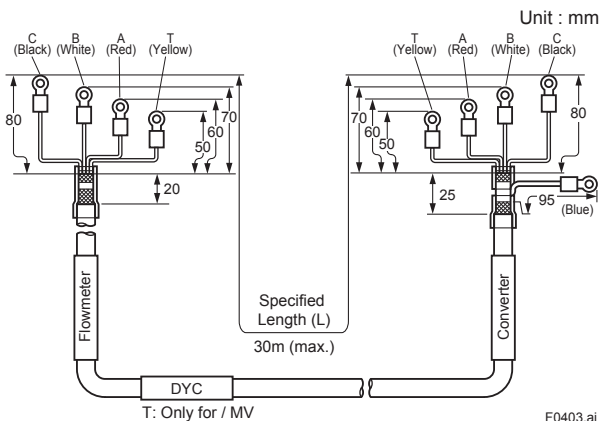

Figure 4.3 DYC Remote Type Signal Cable

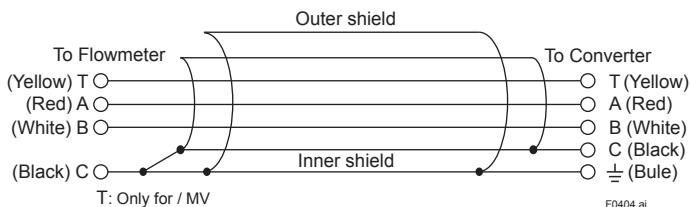
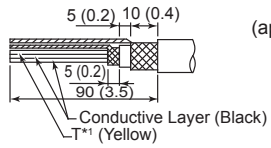
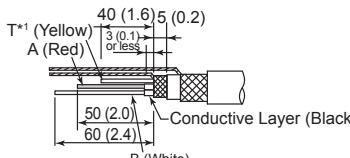
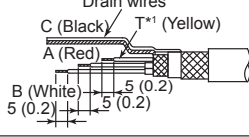
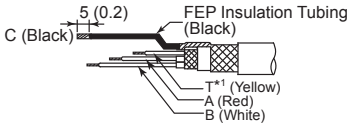
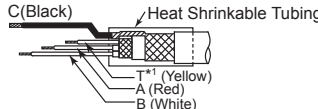
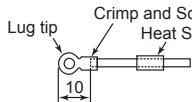
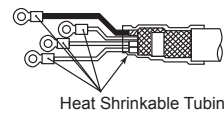
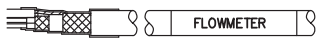

Figure 4.4 Construction of DYC Remote Type Signal Cable

4.5 End Processing Method of DYC Remote Type Signal Cable

4.5.1 For Remote Type Vortex Flowmeter (DY-N)

| | Description | Figure |
|---|---|--|
| 1 | Strip off the outer polyethylene jacket, outer braided shield and inner jacket, and inner braided shield as per the dimensions below. |  |
| 2 | Strip off the black conductive layer covering two wires completely, as per the dimensions below. Twist each of the conductor and drain wires so that there are no free strands. |  |
| 3 | Do not short-circuit the conductive layer and the terminals (A, B, C and T*1). | |
| 4 | Strip off about 5 mm (0.2 in.) of insulation for each of wires A, B, and T*1, and twist the strands of each wire. Twist the inner and outer drain wires together. |  |
| 5 | Slide FEP (fluorinated ethylene propylene) tubing over the twisted inner and outer drain wires C until the tubing cannot be slid any further, and then cut off the tubing leaving 5 mm (0.2 in.) of the stranded drain wires exposed. |  |
| 6 | Slide heat shrinkable tubing over the cable end so that the tubing covers the braided shield and overlaps both the polyethylene jacket and loose wires A, B, C, and T*1. |  |
| 7 | Slide a short piece of heat shrinkable tubing over each of wires A, B, C, and T*1. Install a crimp-on terminal lug at the tip of each wire. Crimp and solder each lug. |  |
| 8 | Slide each short piece of heat shrinkable tubing over the crimp sleeve. Heat all pieces of heat shrinkable tubing with a heat blower or dryer. |  |
| 9 | <p>Attach an identification label to the end of the cable.</p> <p>NOTE</p> <p>Check that the insulation resistance between each wire including the inner shield is 10M or greater at 500V DC. Ensure that both ends of the wires are disconnected (open-circuited) during the check.</p> |  |

(*1): Only for /MV

F0407.ai



NOTE

In case that the cable end finish parts assembly is necessary after delivery, contact your nearest Yokogawa sales office or the sales representative from which you purchased the product.



CAUTION

Do not touch the "conductive layer" (black area covering the signal cables A and B) to the converter case, terminal, and other leadwires. If it is touched, operation of the converter may be incorrect. When the cable is terminated, remove the conductive layer properly.

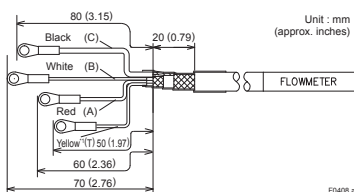

Figure 4.7 End Processing Method of DYC Remote Type Signal Cable for Detector

4.5.2 For Remote Type Vortex Flow Converter (DYA)

| 1 | Description | Figure |
|---|---|--------|
| | Strip off the outer polyethylene jacket, outer braided shield and inner jacket, and inner braided shield as per the dimensions as shown. | |
| | Cut off the black conductive layers (covering the two wires) completely, as per the dimensions below. Twist each of the conductor and drain wires so that there are no free strands. | |
| | Do not short-circuit the conductive layer and the terminals (A, B, C, G, and T*1). | |
| | Strip off about 5 mm (0.2 in.) of insulation for each of wires A, B, and T*1, and twist the strands of each wire. | |
| | Slide black FEP (fluorinated ethylene propylene) tubing over the inner shield drain wire C and blue FEP tubing over outer shield drain wire G until the tubing cannot be slid any further, and then cut off the tubing leaving 5 mm (0.2 in.) of the drain wires exposed. | |
| | Slide heat shrinkable tubing over the cable end so that the tubing covers the braided shield and overlaps both the polyethylene jacket and loose wires A, B, C, G, and T*1. | |
| | Slide a short piece of heat shrinkable tubing over each of wires A, B, C, G, and T*1. Install a crimp-on terminal lug at the tip of each wire. Crimp and solder each lug. | |
| | Slide each short piece of heat shrinkable tubing over the crimp sleeve. Heat all pieces of heat shrinkable tubing with a heat blower or dryer. | |
| | <p>Attach an identification label to the end of the cable.</p> <p>NOTE</p> <p>Check that the insulation resistance between each wire including the inner shield is 10M or greater at 500V DC. Ensure that both ends of the wires are disconnected (open-circuited) during the check.</p> | |

(*1): Only for /MV

F0409.ai

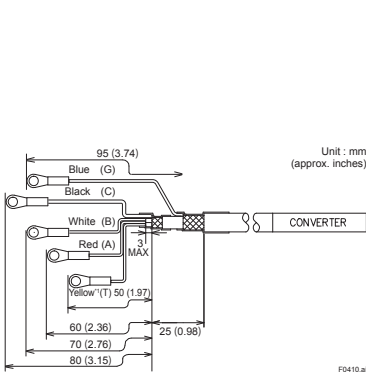

NOTE

In case that the cable end finish parts assembly is necessary after delivery, contact your nearest Yokogawa sales office or the sales representative from which you purchased the product.

CAUTION

Do not touch the "conductive layer" (black area covering the signal cables A and B) to the converter case, terminal, and other leadwires. If it is touched, operation of the converter may be incorrect. When the cable is terminated, remove the conductive layer properly.

Figure 4.8 End Processing Method of DYC Remote Type Signal Cable for Converter

4.6 Wiring Procedures and Precautions



NOTE

Once all wiring is complete, check the connections before applying power to the instrument. Improper arrangements or wiring may cause a unit malfunction or damage.

- (1) Lay wiring as far as possible from electrical noise sources such as large capacity transformers, motors, and power supplies.
- (2) Remove the terminal cover and dustproof plug of an electrical connection before wiring. When you open the cover of explosion protected type (*), turn the Locking Screw to the right, and unlock. When you close a cover after wiring, be sure to turn the Locking Screw to the left and lock.
(*) Flameproof (TIIS, ATEX, IECEx)
- (3) It recommends using an flexible metal conduit and a duct for waterproofing or external protection of an electric wire. Read Figure 4.9 and Figure 4.10.
- (4) The flameproof packing adapter (option code: /G11 or /G12) should be used for the external wiring of TIIS Flameproof. Read "INSTALLATION AND OPERATING PRECAUTIONS FOR TIIS FLAMEPROOF EQUIPMENT."

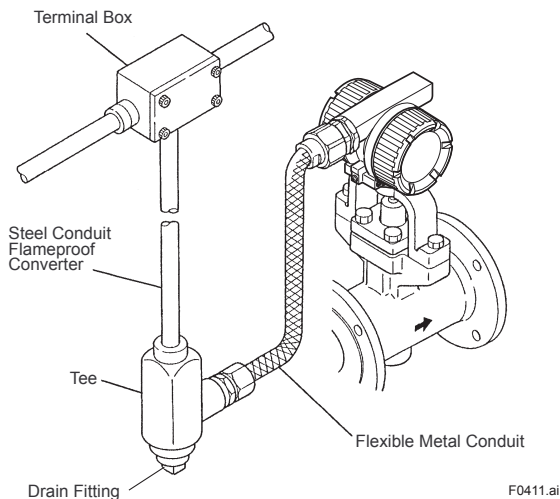

Figure 4.9 Example of Wiring (Integral Type and Remote Type Detector (DY-N))

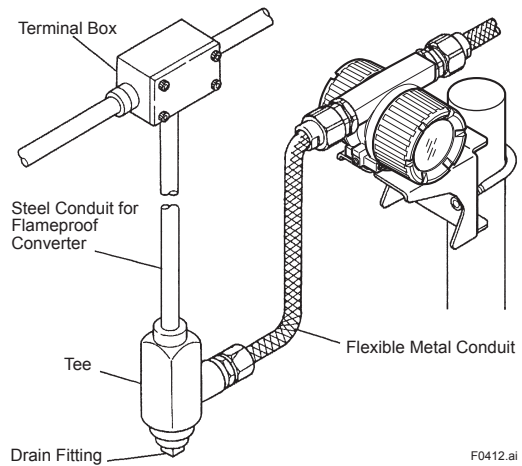

Figure 4.10 Example of Wiring (DYA Remote Type Converter)

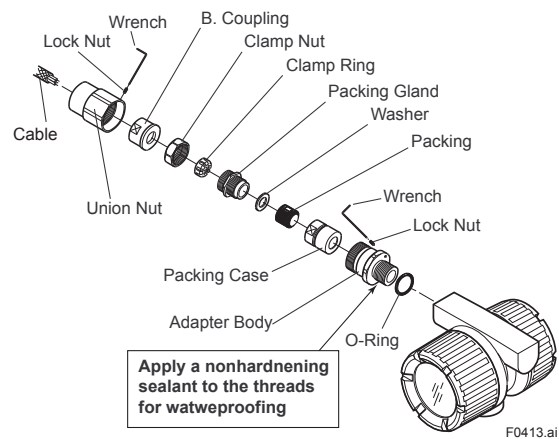
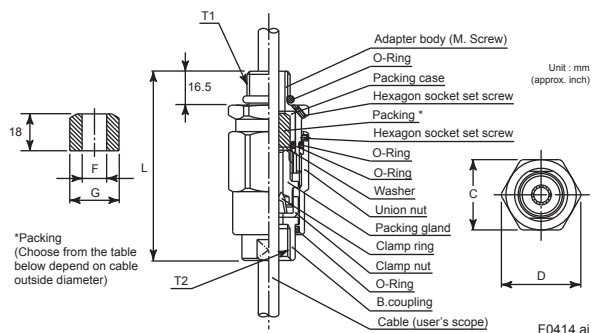

Figure 4.11 Cable Wiring



NOTE

Be sure to use the flameproof packing adapter (option code: /G11 or /G12) for TIIS flameproof type at the time of cable wiring work. Read Figure 4.12.



| Optional Code | Size | | | | | Cable outer diameter | Packing dimensions | | Identification mark | Weight kg (lb) |
|---------------|-------|-------|--------------|--------------|----------------|------------------------------------|--------------------|------------------|---------------------|----------------|
| | T1 | T2 | C | D | L | | F | G | | |
| G11 | G 1/2 | G 1/2 | 35 (1.38) | 39 (1.54) | 94.5 (3.72) | ø8.0 to ø10.0 (ø0.31 to ø0.39) | ø10.0 (ø0.39) | ø20.0 (ø0.79) | 16 8-10 | 0.26 (0.57) |
| G12 | G 1/2 | G 1/2 | 35 (1.38) | 39 (1.54) | 94.5 (3.72) | ø10.0 to ø12.0 (ø0.39 to ø0.47) | ø12.0 (ø0.47) | ø12.0 (ø0.47) | 16 10-12 | |

Figure 4.12 Flameproof Packing Adapter (option code: /G11, /G12)

- (5) Perform attachment of flameproof packing adaptor in the following ways. Read Figure 4.11.
 - (a) Loosen the locking screw and remove the terminal box cover.
 - (b) Measure the cable outer diameter in two directions to within 0.1 mm.
 - (c) Calculate the average of the two diameters, and use packing with an internal diameter nearest to this value. Read Table 4.2.
 - (d) Screw the flameproof packing adaptor into the terminal box until the O-Ring touches the wiring port (at least 6 full turns), and firmly tighten the lock nut.
 - (e) Insert the cable through the union nut, the B. coupling, the clamp nut, the clamp ring, the packing gland, the washer, the packing, and the packing case, in that order.
 - (f) Insert the end of the cable into the terminal box.
 - (g) Tighten the union cover to grip the cable. When tightening the union cover, tighten approximately one turn past the point where the cable will no longer move up and down. Proper tightening is important. If it is too tight, a circuit break in the cable may occur; if not tight enough, the flameproof effectiveness will be compromised.
 - (h) Fasten the cable by tightening the clamp nut.
 - (i) Tighten the lock nut on the union nut.
 - (j) Connect the cable wires to each terminal.
- (6) Be sure to observe the following precautions when wiring.
 - (a) Do not connect cables outdoors in wet weather in order to prevent damage from condensation and to protect the insulation.
 - (b) Do not splice the cable between the flowtube terminal and the converter if it is too short. Replace the short cable with a cable that is the appropriate length.
 - (c) The signal cables must be routed in separate steel conduit tubes 16 (JIS C 8305) or flexible conduit tubes 15 (JIS C 8309).
 - (d) Always route the power and output signal cables in separate steel conduit tubes, except when the power supply voltage is 24 V and four-core cables are used for wiring. Keep conduits or flexible tubes watertight using sealing tape.

4.7 Grounding



IMPORTANT

When a lightning protector (option code: /A) is selected, use a grounding resistance of 10Ω or less.

- (1) The grounding terminals \perp are located on the inside and outside of the terminal area. Either terminal may be used. Read Figure 4.13.
- (2) For pulse output version, ground the flowmeter. Also ground the shielded cable between the converter and the pulse receiver.
- (3) Grounding should satisfy Class D requirements (ground resistance 100Ω or less).
- (4) Use 600V PVC insulated wire for grounding.

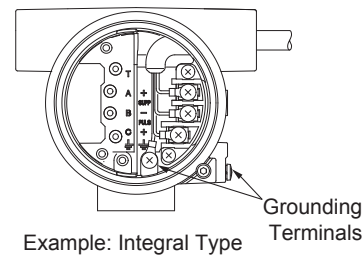

F0415.ai

Figure 4.13 Grounding Terminal

5. BASIC OPERATING PROCEDURES

Data setting can be performed with the three keys on the front panel (SET, SHIFT and INC) or using a handheld BRAIN TERMINAL (BT200) and HART communicator.

5.1 Display Configuration

Figure 5.1 shows the configuration of the digital YEW FLO display panel (if equipped).

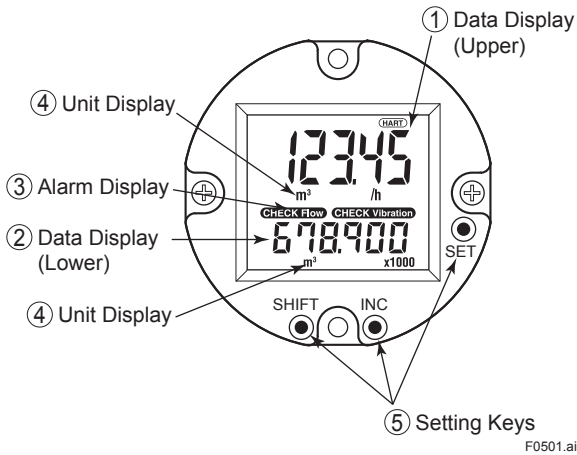

F0501.ai

Figure 5.1 Display Configuration

- ① Data Display(Upper) : flowrate data, setting data, total data
temperature data (/MV)
- ② Data Display(Lower) : total data, alarm data
temperature data (/MV)
- ③ Alarm Display : alarm of a flow error and a vibration error
- ④ Unit Display : flowrate unit
- ⑤ Setting Keys : These keys are used to change flow rate data displays and type of setting data

5.2 Display Contents

The display content items are classified in the following three items.

Table 5.1 Mode Name List

| Mode (status) Name | Display Contents |
|---------------------------|--|
| Flow rate display mode | A mode in which instantaneous flow rates or totalized values are displayed. Display content is usually selected either in display content selection mode or by setting parameters via BRAIN communication. |
| Setting mode | In this mode, parameter contents are confirmed or data is updated using the setting section. The mode is changed to this mode when "SET" key is pressed in normal mode. |
| Alarm number display mode | This mode is overlapped when an alarm is occurring in display mode. The alarm number presentation to indicate alarm contents (about 2 sec) and the normal data display (about 4 sec) are repeated alternately. |

Mode represents that the system is in a state where the relevant setting or display is possible.

• Display Example

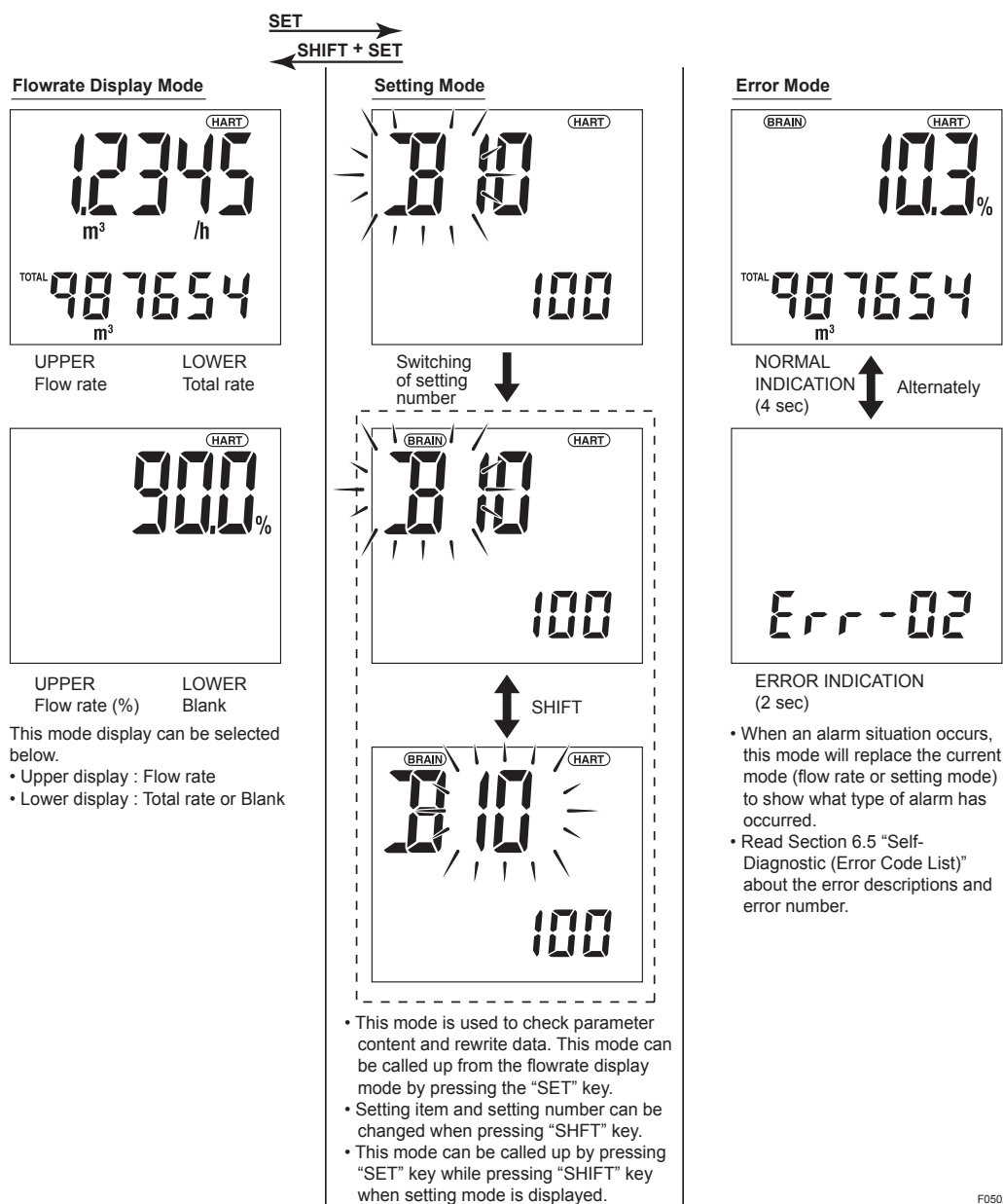

F0502.ai

5.3 Display Mode

The display mode is a mode in which instantaneous flow rates or totalized flow are displayed. In display mode, there are three display modes as shown in Table 5.2.

Table 5.2 Display Mode

| Name | Contents | Upper Display | Lower Display |
|------------------------------|--|---------------|---------------|
| % Display (Flow rate) | Instantaneous % flow rate is displayed. | ○ | × |
| Engineering Display Unit | Instantaneous flow rate in an engineering unit is displayed. | ○ | × |
| Totalized Display | Totalized flow displayed without indicating the decimal point. | × | ○ |
| % Display (Temperature) (*1) | Instantaneous temperature is displayed. In this case, "t" is displayed simultaneously (Read Figure 5.2). | ○ | × |
| Temperature display(*1) | Temperature value is displayed. | × | ○ |
| Blank | — | × | ○ |

(*1) Only for /MV.

○: Displayed ×: Not displayed

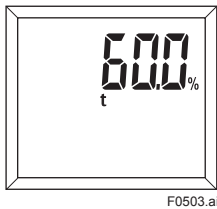

Figure 5.2 % Display (Temperature)

Display mode can be changed using the BT200 or the indicator setting section.

- (1) For operation using BT200, perform changes using the parameter item " B30:UPPER DISP" and "B31:LOWER DISP".
- (2) For operation using indicator, change B30 and B31 parameter item number to display an appropriate display.



IMPORTANT

After setting a parameter, keep the power on for at least 30 seconds.

If the power of flowmeter is turned off, a parameter setting is released.

5.3.1 Changes to Engineering Display Unit from % Display

The display mode can be changed by reading Section 6.3 “Parameters List.”

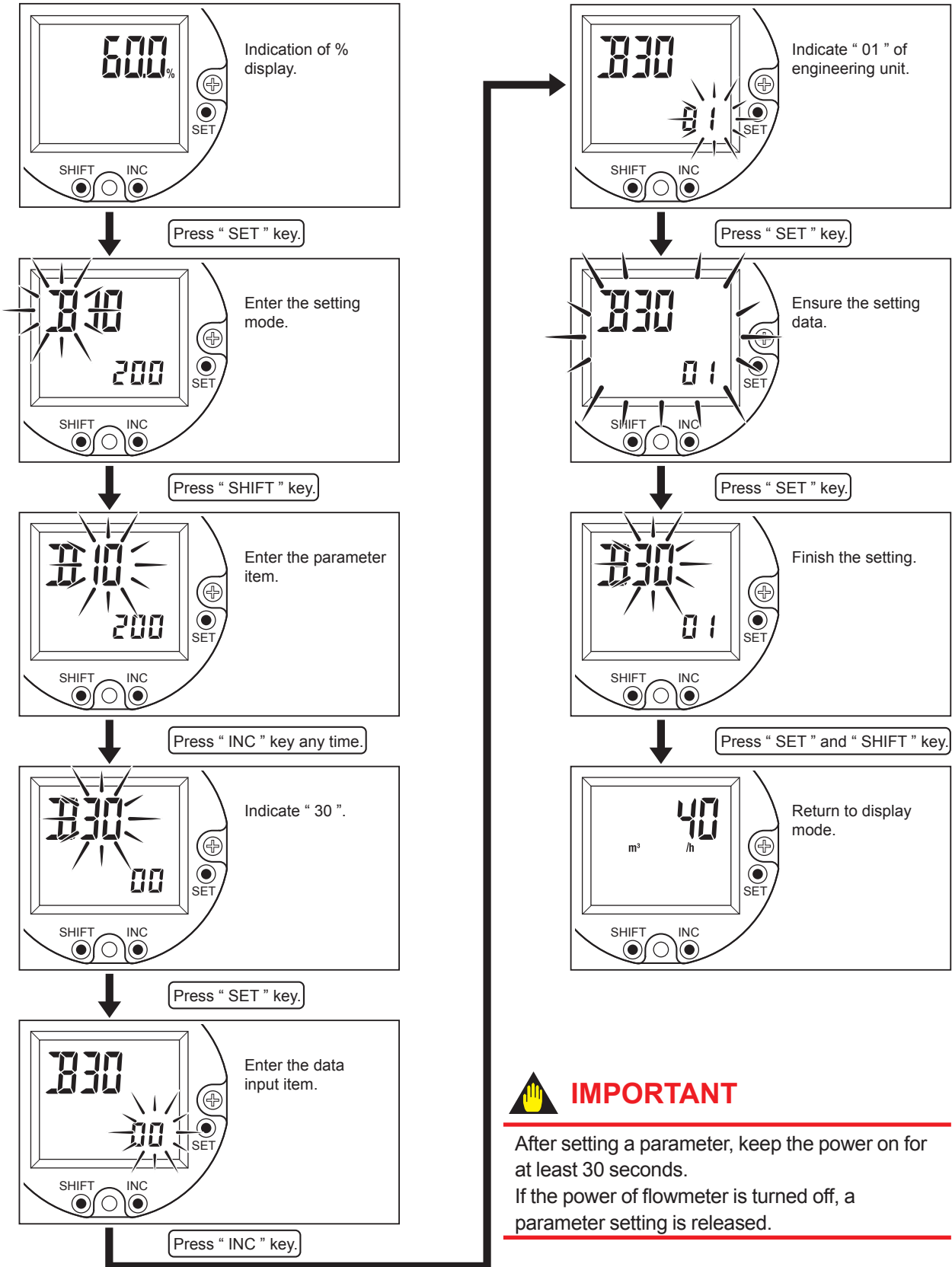

IMPORTANT

After setting a parameter, keep the power on for at least 30 seconds.
If the power of flowmeter is turned off, a parameter setting is released.

F0504.ai

5.3.2 Indicate the Total Rate in the Data Display(Lower)

The display mode can be changed by reading Section 6.3 "Parameters List."

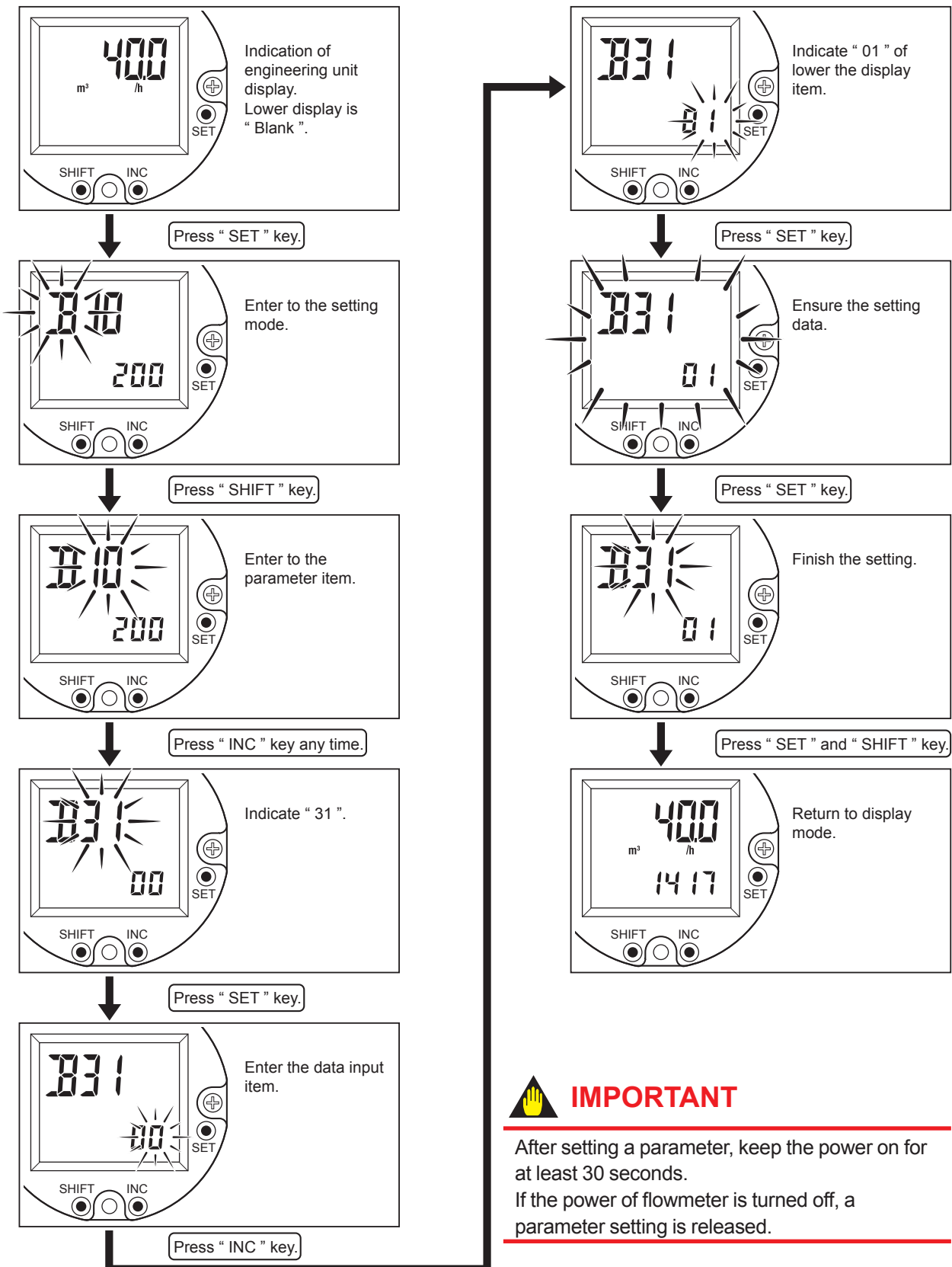

 **IMPORTANT**

After setting a parameter, keep the power on for at least 30 seconds.
If the power of flowmeter is turned off, a parameter setting is released.

F0505.ai

5.4 Setting Mode

The setting mode is used for checking parameters and rewriting data. The following is an overview of the setting mode.



NOTE

- Read Section 6.3 “Parameters List” and Section 6.4 “Parameters Description” on how to change setting.

5.4.1 Display Configuration of Setting Mode

Simple parameter sheet

In this sheet, a setting flow chart and the parameter list required to operate digital YEW FLO is indicated.

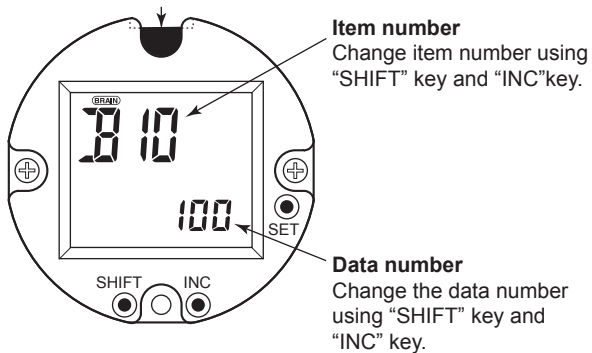

F0506.ai

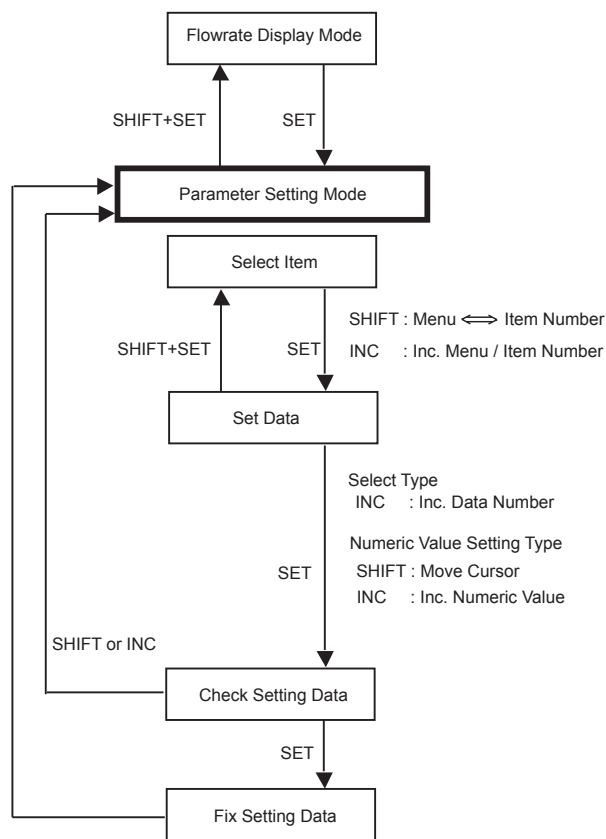

F0507.ai

Figure 5.3 Indicator Configuration and Parameter Setting Procedure

- When completing setting, press “SHIFT” key and “SET” key simultaneously. The mode move to the “display mode”.



IMPORTANT

After setting a parameter, keep the power on for at least 30 seconds.
 If the power of flowmeter is turned off, a parameter setting is released.

5.4.2 Data Setting Method

Input method of numeric data

Example 1: Change the span from 100m³/h to 150m³/h

The setting mode can be changed by reading Section 6.3 "Parameters List."

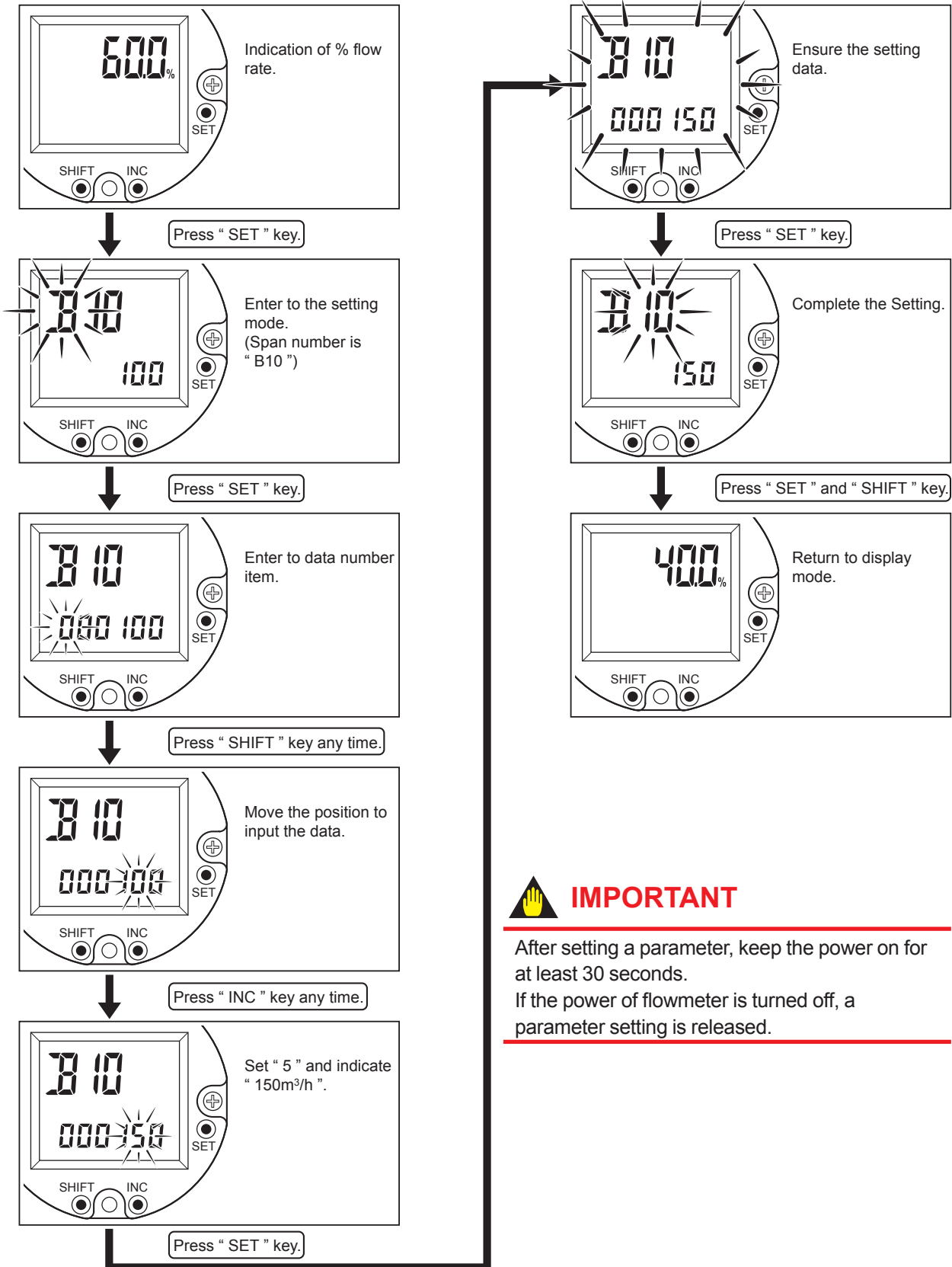

IMPORTANT

After setting a parameter, keep the power on for at least 30 seconds.

If the power of flowmeter is turned off, a parameter setting is released.

■ Input method of selection items

Example 2: Change the pulse output to alarm output.

The setting mode can be changed by reading Section 6.3 "Parameters List."

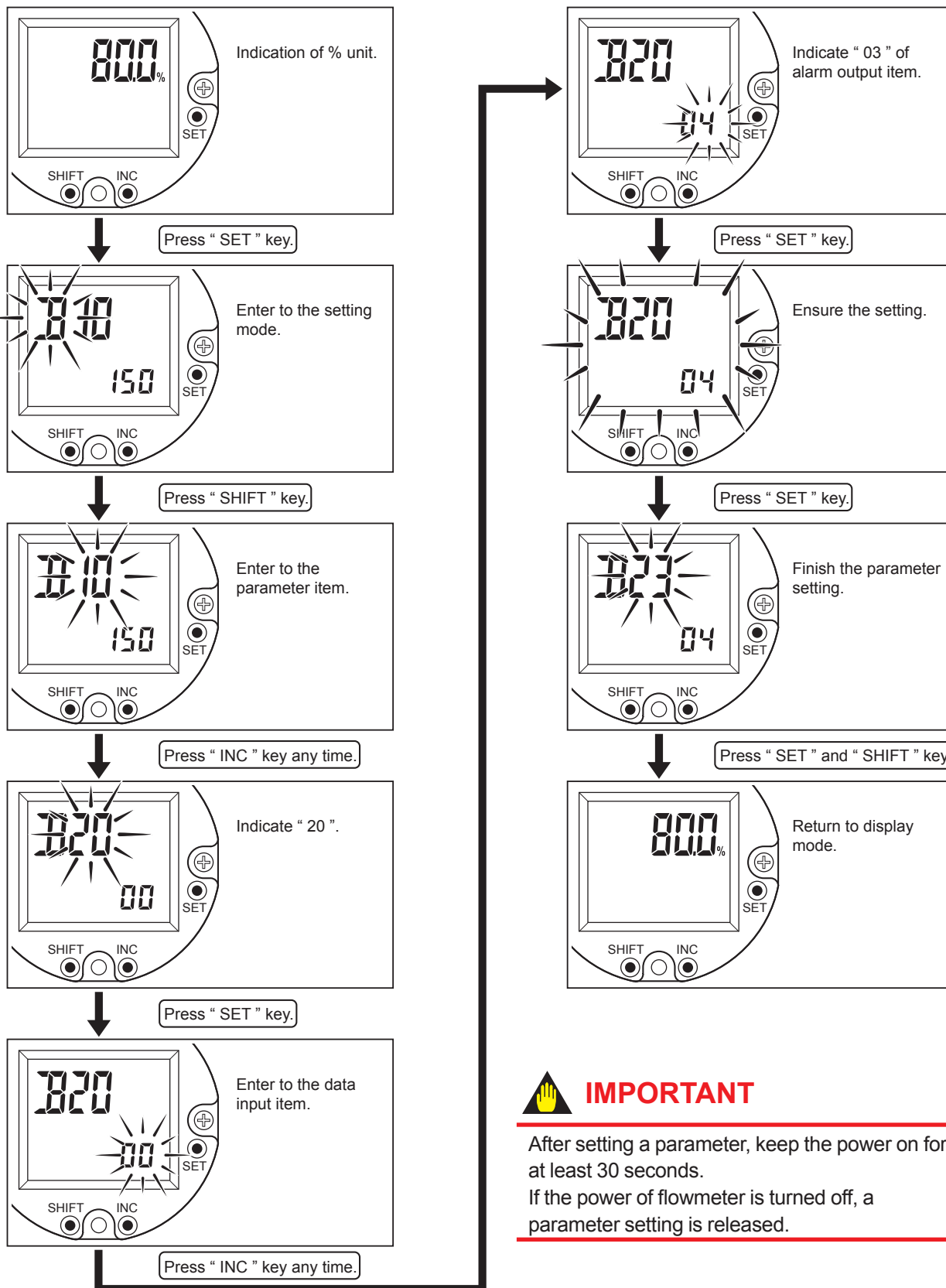

 **IMPORTANT**

After setting a parameter, keep the power on for at least 30 seconds.

If the power of flowmeter is turned off, a parameter setting is released.

F0509.ai

6. PARAMETERS

6.1 digitalYEWFO Parameters

The parameters are set before factory shipment. Set the required parameter of changing fluid, contact out and indication of display.

6.2 Multi-Variable Type (/MV) Parameters

Parameter item F is indicated when /MV is selected. The parameters are set before factory shipment, but it is necessary to set the analog output of temperature, span of temperature output.



IMPORTANT

For the remote type, be sure to set the cable length (F52) for remote type converter (DYA), because of effect of the cable length.

6.3 Parameters List

This section describes the parameter of digitalYEWFO.

- Contents of parameters list.

| Item | Description |
|------------------------------|--|
| Item | Parameter item number. |
| Name | Parameter name. |
| R / W (Read and Write) | Indicates parameter attributes. R : Display only (writing is not permitted). W : Writing is permitted. |
| Data Range | Shows data setting ranges for numerical value entry. Shows data to be selected for data selection. () in parentheses, data code is shown for the display. |
| Unit | Engineering unit. |
| Remark | Remarks such as a description of the contents are given. |
| Initial value | Indicates the initial set values. |
| Disp. | D : Display can set parameter. |
| U / D | L : Parameter can be set by UP LOAD and DOWN LOAD. (Check all parameters after setting by DOWN LOAD.) |

(1) Item A : Indication

These items are for the indication of flowrate and total.

| Item | Name | R / W | Data Range | Unit | Decimal Point | Remark | Initial Value | Disp. | U / D (*1) |
|--|------------------|-------|------------------|--------|---------------|---------------------------------|---------------|-------|------------|
| A00 | DISPLAY | | | | | Menu A (Display) | | | |
| A10 | FLOW RATE (%) | R | 0.0 to 110.0 | % | 1 | Flow Rate | | | |
| A20 | FLOW RATE | R | 0.0 to 65535 | FU+C40 | 0 to 5 | Flow Rate (in engineering unit) | | | |
| A30 | TOTAL | R | 0 to 999999 (*2) | FU | 0 to 5 | Totalized Value | | | |
| (Indicate only for /MV and B50 : TEMP) | | | | | | | | | |
| A40 | TEMP (%) (*1) | R | 0.0 to 110.0 | % | 1 | Temperature Values (%) | | | |
| (Indicate only for /MV) | | | | | | | | | |
| A41 | TEMPERATURE (*1) | R | -999.9 to 999.9 | D20 | 1 | Temperature Values | | | |
| A60 | SELF CHECK | R | GOOD ERROR | | | Self-diagnostic message | | | |

FU : Flow unit

/MV: Multi-Variable (Build-in Temperature Sensor) Type

(*1) : Available for 3.10 or greater version that can be checked in K50.

(*2) : There will be linked to the value of B45, it is displayed "E" shows multiplier 10.

(2) Item B : Easy Setting

These items are for the principal items to operate digital YEW FLO.

A value in "()" is the data corresponding to the indicator.

| Item | Name | R / W | Data Range | Unit | Decimal Point | Remark | Initial Value | Disp. | U / D (*1) |
|---|----------------|-------|--|----------|---------------|--|---------------|-------|------------|
| B00 | EASY SETUP | | | | | Menu B | | | |
| B10 | FLOW SPAN | W | 0.00001 to 32000 | FU + C40 | 0 to 5 | Flow Span | 10 | D | L |
| B15 | DAMPING | W | 0 to 99 | sec | 0 | Damping Time | 4 | D | L |
| B20 | CONTACT OUT | W | OFF (0) SCALED PULSE (1) UNSCALED PULSE (2) FREQUENCY (3) ALARM (4) FLOW SW(LOW:ON) (5) FLOW SW(LOW:OFF) (6) | | | Contact Output Type | (0) | D | L |
| (Indicate and Set only for B20: SCALED PULSE, UNSCALED PULSE) | | | | | | | | | |
| B21 | PULSE RATE | W | 0.00001 to 32000 | FU / P | 0 to 5 | Pulse Output Rate | 1.0 (*3) | D | L |
| (Indicate and Set only for B20: FREQUENCY) | | | | | | | | | |
| B22 | FREQ AT 100% | W | 0 to 10000 | PPS | 0 | Pulse Output Rate at sec /100% | 1000 | D | L |
| (Indicate and Set only for B20: FLOW SW (ON), FLOW SW (OFF)) | | | | | | | | | |
| B23 | SET LEVEL | W | 0.00001 to 32000 | FU+C40 | 0 to 5 | Flow Switch (Actual Flow rate) | 0 | D | L |
| B30 | UPPER DISP | W | FLOW RATE (%) (0) FLOW RATE (1) TEMP (%) (2) | | | Selection of Upper Display | (0) (*3) | D | L |
| B31 | LOWER DISP | W | BLANK (0) TOTAL (1) TEMP (2) | | | (only for /MV) Selection of Lower Display | (0) | D | L |
| B40 | TOTAL START | W | STOP (0) START (1) | | | (only for /MV) Start / Stop of Totalizer | (0) | D | L |
| B45 | TOTAL RATE | W | 0.00001 to 32000 | FU / P | 0 to 5 | Total Rate | 1.0 (*3) | D | L |
| B47 | TOTAL RESET | W | NOT EXECUTE (0) EXECUTE (1) | | | Totalizer Reset | (0) | D | L |
| (Indicate and Set only for /MV) | | | | | | | | | |
| B50 | A / OUT SELECT | W | FLOW (0) TEMP (1) | | | Selection of Analog Output | (0) | D | L |
| (Indicate and Set only for /MV and B50: TEMP) | | | | | | | | | |
| B51 | TEMP 0% | W | -999.9 to 999.9 | D20 | 1 | Set Temperature Value at 0% | -40 | D | L |
| B52 | TEMP 100% | W | -999.9 to 999.9 | D20 | 1 | Set Temperature Value at 100% | 250 (*2) | D | L |
| B60 | SELF CHECK | R | GOOD ERROR | | | Self-diagnostic Message | | | |

FU : Flow unit

(*1) : Available for 3.10 or greater version that can be checked in K50.

(*2) : If 7.00 or less version that can be checked in K50, Initial Value is 260.

(3) Item C : BASIC SETUP

These items are for the basic parameters with setting before shipment.

The parameters, C20 to C50, are not indicated when option code "/MV" is selected and parameter item is selected in F10 except "Monitor only" or "Not use".

A value in "()" is the data corresponding to the indicator.

| Item | Name | R / W | Data Range | Unit | Decimal Point | Remark | Initial Value | Disp. | U / D ^(*) |
|------|--------------|-------|---|------|---------------|--|---------------------|-------|----------------------|
| C00 | BASIC SETUP | | | | | | | | |
| C10 | TAG NO. | W | 16 characters | | | Tag Number | (⁽²⁾) | | |
| C20 | FLUID | W | LIQUID:Volume (0) GAS/STEAM:Volume (1) LIQUID:Mass (2) GAS/STEAM:Mass (3) GAS:STD/Normal (4) | | | Selection of FLUID type | (0) ⁽²⁾ | D | L |
| C22 | VOLUME UNIT | W | (Indicate and Set only for C20 : LIQUID : Volume, GAS / STEAM: Volume) m ³ (0) k m ³ (1) l (2) cf (3) m cf (4) k cf (5) USgal (6) k USgal (7) UKgal (8) k UKgal (9) bbl (10) m bbl (11) k bbl (12) | | | Selection of Flow Units for Flow Rate | (0) ⁽²⁾ | D | L |
| C25 | DENSITY UNIT | W | (Indicate and Set only for C20 : LIQUID : Mass, GAS / STEAM : Mass) kg/m ³ (0) lb/cf (1) lb/USgal (2) lb/UKgal (3) | | | Selection of Density Unit | (0) ⁽²⁾ | D | L |
| C26 | DENSITY f | W | 0.00001 to 32000 | C25 | 0 to 5 | Operating Density (Manual Setting Value) | 1024 ⁽²⁾ | D | L |
| C27 | MASS UNIT | W | kg (0) t (1) lb (2) k lb (3) | | | Selection of Mass Flow Unit | (0) ⁽²⁾ | D | L |

| Item | Name | R / W | Data Range | Unit | Decimal Point | Remark | Initial Value | Disp. | U / D ^(*) |
|------|--------------|-------|--|--------|---------------|--|-----------------------|-------|----------------------|
| C30 | TEMP UNIT | W | (Indicate and Set only for C20 : GAS : STD / Normal) deg C (0) deg F (1) | | | Selection of Temperature Unit | (0) ^(*) | D | L |
| C31 | TEMP f | W | -999.9 to 999.9 | C30 | 1 | Operating Temperature (Manual Setting Value) | 15.0 ^(*) | D | L |
| C32 | TEMP b | W | -999.9 to 999.9 | C30 | 1 | Standard / Normal Temperature | 15.0 ^(*) | D | L |
| C33 | PRESS UNIT | W | MPa abs (0) kPa abs (1) bar abs (2) kg/cm ² a (3) psia (4) | | | Selection of Pressure Unit | (0) ^(*) | D | L |
| C34 | PRESS f | W | 0.00001 to 32000 | C33 | 0 to 5 | Absolute Pressure at Operating Condition (Manual Setting Value) | 0.1013 ^(*) | D | L |
| C35 | PRESS b | W | 0.00001 to 32000 | C33 | 0 to 5 | Absolute Pressure at Standard Condition | 0.1013 ^(*) | D | L |
| C36 | DEVIATION | W | 0.001 to 10.0 | | 3 | Deviation Factor | 1.0 ^(*) | D | L |
| C37 | STD/NOR UNIT | W | Nm ³ (0) k Nm ³ (1) M Nm ³ (2) NI (3) Sm ³ (4) k Sm ³ (5) M Sm ³ (6) SI (7) scf (8) k scf (9) M scf (10) | | | Selection of Volumetric Unit at Normal Condition N: Normal S: Standard | (0) ^(*) | D | L |
| C40 | TIME UNIT | W | /s (0) /m (1) /h (2) /d (3) | | | Selection of Time Unit | (2) ^(*) | D | L |
| C45 | FLOW SPAN | W | 0.00001 to 32000 | FU+C40 | 0 to 5 | Flow Span | 10 ^(*) | D | L |
| C50 | DAMPING | W | 0 to 99 | sec | 0 | Damping Time | 4 | D | L |
| C60 | SELF CHECK | R | GOOD ERROR | | | Self-diagnostic Message | | | |

FU : Flow unit

(*1) : Available for 3.10 or greater version that can be checked in K50.

(*2) : If specified when ordering, it is set to the specified contents.

(4) Item D : Additional Setup

These items are for Auxiliary Setup.

A value in “ () ” is the data corresponding to the indicator.

| Item | Name | R / W | Data Range | Unit | Decimal Point | Remark | Initial Value | Disp. | U / D ^{(*)1} |
|---|---------------|-------|--|----------|---------------|---|----------------------|-------|-----------------------|
| D00 | AUX. SETUP | | | | | Menu D (Additional Setup) | | | |
| D10 | LOW CUT | W | * to 32000 | FU + C40 | 0 to 5 | Low Cut Flow Rate *Minimum Flow Rate / 2 | 0.47 | D | |
| D20 | TEMP UNIT | W | deg C (0) deg F (1) | | | Selection of Temperature Unit | (0) ^{(*)2} | D | L |
| D21 | TEMP f | W | -999.9 to 999.9 | D20 | 1 | Operating Temperature (Manual Setting Value) | 15.0 ^{(*)2} | D | L |
| D25 | DENSITY UNIT | W | kg/m ³ (0) lb/cf (1) lb/USgal (2) lb/UKgal (3) | | | Selection of Density Unit | (0) ^{(*)2} | D | L |
| D26 | DENSITY f | W | 0.00001 to 32000 | D25 | 0 to 5 | Operating Density (Manual Setting Value) | 1024 ^{(*)2} | D | L |
| D30 | OUT LIMIT (H) | W | 100.0 to 110.0 | % | 1 | Upper Limit Value | 110.0 | D | L |
| D35 | BURN OUT | R | High (0) Low (1) | | | Output Direction at Burn Out | (0) | D | L |
| D40 | SPECIAL UNIT | W | No (0) Yes (1) Special (2) | | | Selection of change for Special Flow Unit | (0) | D | L |
| (Indicate and Set only for D40: Yes, Special) | | | | | | | | | |
| D41 | BASE UNIT | R | m ³ (0) k m ³ (1) l (2) cf (3) m cf (4) k cf (5) USgal (6) kUSgal (7) UKgal (8) kUKgal (9) bbl (10) m bbl (11) k bbl (12) kg (13) t (14) lb (15) k lb (16) Nm ³ (17) k Nm ³ (18) M Nm ³ (19) NI (20) Sm ³ (21) k Sm ³ (22) M Sm ³ (23) SI (24) scf (25) k scf (26) M scf (27) | | | Basic unit for conversion to Special Unit N: Normal S: Standard | | D | |
| D42 | USER'S UNIT | W | 8 characters | | | User's Unit ^{(*)3} | | | L |
| D43 | CONV FACTOR | W | 0.00001 to 32000 | | 0 to 5 | Conversion Factor | 1.0 | D | L |
| D60 | SELF CHECK | R | GOOD ERROR | | | Self-diagnostic Message | | | |

FU : Flow unit

(*)1 : Available for 3.10 or greater version that can be checked in K50.

(*)2 : If specified when ordering, it is set to the specified contents.

(*)3 : Available characters are same as C10.

Read Section 6.4 "Parameters Description."

(5) Item E : Detector Setup

These items are for detector that has been already set before.

A value in “()” is the data corresponding to the indicator.

| Item | Name | R / W | Data Range | Unit | Decimal Point | Remark | Initial Value | Disp. | U / D ^(*) |
|------|--------------|-------|---|------|---------------|----------------------------|---------------------|-------|----------------------|
| E00 | METER SETUP | | | | | Menu E (Detector setup) | | | |
| E10 | NOMINAL SIZE | W | 15mm (0) 25mm (1) 40mm (2) 50mm (3) 80mm (4) 100mm (5) 150mm (6) 200mm (7) 250mm (8) 300mm (9) 400mm (10) | | | Selection of Nominal Size | (1) ^{(*)2} | D | L |
| E20 | BODY TYPE | W | Standard (0) High Pressure (1) Low Flow Unit (1) (2) Low Flow Unit (2) (3) | | | Selection of Body Type | (0) | D | L |
| E30 | SENSOR TYPE | W | Standard (0) High Temperature (1) Low Temperature (2) | | | Selection of Sensor Type | (0) | D | L |
| E40 | K-FACT UNIT | W | P/I (0) P/USgal (1) P/UKgal (2) | | | Selection of K-factor Unit | (0) | D | L |
| E41 | K-FACTOR | W | 0.00001 to 32000 | E40 | 0 to 5 | K-factor value of 15 deg C | 68.6 | D | |
| E50 | DETECTOR No. | W | 16 characters | | | Detector Number | | | |
| E60 | SELF CHECK | R | GOOD ERROR | | | Self-diagnostic Message | | | |

FU : Flow unit

(*1) : Available for 3.10 or greater version that can be checked in K50.

(*2) : If specified when ordering, it is set to the specified contents.

(6) Item F: Thermometer (Only for Multi-Variable Type)

These items is for thermometer setting when.

A Value in “()” is the data corresponding to the indicator.

| Item | Name | R / W | Data Range | Unit | Decimal Point | Remark | Initial Value | Disp. | U / D ^(*) |
|--|--------------|-------|--|------|---------------|---|---------------|-------|----------------------|
| F00 | THERMOMETER | | | | | Menu F (Thermometer function) | | | |
| F10 | Function | W | Monitor only (0) Saturated Steam (1) Superheat Steam (2) GAS: STD/Normal (3) LIQUID: Mass (4) Not use (5) | | | Select thermometer function. (Move to F40 when “Monitor only” is selected) (Move to F60 when “Not Use” is selected) | (0) | D | L |
| (Indicate and Set only for F10: Saturated Steam) | | | | | | | | | |
| F12 | MASS UNIT | W | kg (0) t (1) lb (2) k lb (3) | | | Selection of mass flow rate unit | (0) | D | L |
| (Indicate and Set only for F10: Superheat Steam) | | | | | | | | | |
| F14 | PRSS UNIT | W | MPa abs (0) kPa abs (1) bar abs (2) kg/cm ² a (3) psia (4) | | | Selection of pressure unit | (0) | D | L |
| F15 | PRESS f | W | 0.00001 to 32000 | F14 | 0 to 5 | Absolute pressure at operating condition(Manual setting value) | 0.1013 | | |
| F16 | MASS UNIT | W | kg (0) t (1) lb (2) k lb (3) | | | Selection of mass flow rate unit | (0) | D | L |
| (Indicate and Set only for F10: GAS: STD/Normal) | | | | | | | | | |
| F18 | TEMP UNIT | W | deg C (0) deg F (1) | | | Selection of temperature unit | (0) | D | L |
| F19 | TEMP b | W | -999.9 to 999.9 | F18 | 1 | Standard/Normal temperature | 15.0 | D | L |
| F20 | PRESS UNIT | W | MPa abs (0) kPa abs (1) bar abs (2) kg/cm ² a (3) psia (4) | | | Selection of temperture unit | (0) | D | L |
| F21 | PRESS f | W | 0.00001 to 32000 | F20 | 0 to 5 | Absolute pressure at operating condition(Manual setting value) | 0.1013 | D | L |
| F22 | PRESS b | W | 0.00001 to 32000 | F20 | 0 to 5 | Absolute pressure at Standard condition | 0.1013 | D | L |
| F23 | DEVIATION | W | 0.001 to 10.000 | | 3 | Deviation factor | 1.0 | D | L |
| F24 | STD/NOR UNIT | W | Nm ³ (0) k Nm ³ (1) M Nm ³ (2) NI (3) Sm ³ (4) k Sm ³ (5) M Sm ³ (6) SI (7) scf (8) k scf (9) M scf (10) | | | Selection of volumetric unit at normal condition N: Normal S: Standard | (0) | D | L |

| Item | Name | R / W | Data Range | Unit | Decimal Point | Remark | Initial Value | Disp. | U / D ^(*1) |
|---|--------------|-------|--|--------------------|---------------|---|---------------------|-------|-----------------------|
| (Indicate and Set only for F10: LIQUID: Mass) | | | | | | | | | |
| F26 | DENSITY UNIT | W | kg/m ³ (0) lb/cf (1) lb/USgal (2) lb/UKgal (3) | | | Selection of density unit | (0) | D | L |
| F27 | DENSITY b | W | 0.00001 to 32000 | F26 | 0 to 5 | Density of standard condition | 1.0 | D | L |
| F28 | TEMP UNIT | W | deg C (0) deg F (1) | | | Selection of temperature unit | (0) | D | L |
| F29 | TEMP b | W | -999.9 to 999.9 | F28 | 1 | Temperature of standard condition | 15.0 | D | L |
| F30 | 1st coef | W | -32000 to 32000 | 1/F28 | 0 to 5 | 1st temperature coefficient | 1.0 | D | L |
| F31 | 2nd coef | W | -32000 to 32000 | 1/F28 ² | 0 to 5 | 2nd temperature coefficient | 1.0 | D | L |
| F32 | MASS UNIT | W | kg (0) t (1) lb (2) k lb (3) | | | Selection of mass flow rate unit | (0) | D | L |
| F35 | TIME UNIT | W | /s (0) /m (1) /h (2) /d (3) | | | Selection of time unit | 1 | D | L |
| F40 | FLOW SPAN | W | 0.00001 to 32000 | FU+35 | 0 to 5 | Flow span | 0.5 | D | L |
| F45 | DAMPING | W | 0 to 99 | sec | 0 | Damping | 4 | D | L |
| F50 | TEMP DAMPING | W | 0 to 99 | sec | 0 | Damping for temperture output | 4 | D | L |
| F52 | CABLE LENGTH | W | 0 to 30 | m | 0 | Cable length for signal cable (0m in case of integral version) | 0 | D | L |
| F55 | A/OUT SELECT | W | FLOW (0) TEMP (1) | | | Selection of analog output | (0) | D | L |
| (Indicate and Set only for F55: TEMP) | | | | | | | | | |
| F56 | TEMP 0% | W | -999.9 to 999.9 | D20 | 1 | Temperture value at 0% | -40 | D | L |
| F57 | TEMP 100% | W | -999.9 to 999.9 | D20 | 1 | Temperture value at 100% | 250 ^(*2) | D | L |
| F58 | TEMP ERR OUT | W | 0% (0) OUT LIMIT(H) (1) TEMP f (2) | | | Selection of themometer error output when "F55: TEMP" is selected (A value of OUT LIMIT(H) depend on D30) | 1 | D | L |
| F60 | SELF CHECK | R | GOOD ERROR | | | Self-diagnostic Message | | | |

(*1) : Available for 3.10 or greater version that can be checked in K50.

(*2) : If 7.00 or less version that can be checked in K50, Initial Value is 260.

(7) Item H : Adjust.

These items are for setting of adjustment.

A value in "()" is the data corresponding to the indicator.

| Item | Name | R / W | Data Range | Unit | Decimal Point | Remark | Initial Value | Disp. | U / D ^(*) |
|--|--------------|-------|------------------------------|-------|---------------|---|---------------|-------|----------------------|
| H00 | ADJUST | | | | | Menu H (Adjust) | | | |
| H10 | TRIM 4mA | W | -1.00 to 1.00 | % | 2 | Trimming 4mA | 0.0 | D | |
| H11 | TRIM 20mA | W | -1.00 to 1.00 | % | 2 | Trimming 20mA | 0.0 | D | |
| H20 | USER ADJUST | W | 0.00001 to 32000 | | 0 to 5 | User Adjust | 1.0 | D | |
| H25 | REYNOLDS ADJ | W | NOT ACTIVE (0) ACTIVE (1) | | | Reynolds Coefficient | (0) | D | |
| (Indicate and Set only for H25: ACTIVE) | | | | | | | | | |
| H26 | DENSITY f | W | 0.00001 to 32000 | D25 | 0 to 5 | Density at operating condition | 1024 | D | |
| H27 | VISCOSITY | W | 0.00001 to 32000 | mPa.s | 0 to 5 | Viscosity factor | 1.0 | D | |
| H30 | EXPANSION FA | W | NOT ACTIVE (0) ACTIVE (1) | | | Expansion correction for compressible Gas | (0) | D | |
| H40 | FLOW ADJUST | W | NOT ACTIVE (0) ACTIVE (1) | | | Instrumental Error Adjust | (0) | D | |
| (Indicator and Set only for H40: ACTIVE) | | | | | | | | | |
| H41 | FREQUENCY 1 | W | 0 to 32000 | Hz | 0 to 5 | First break-point frequency (f1) | 0.0 | D | |
| H42 | DATA 1 | W | -50.00 to 50.00 | % | 2 | First correcting value (d1) | 0.0 | D | |
| H43 | FREQUENCY 2 | W | 0 to 32000 | Hz | 0 to 5 | Second break-point frequency (f2) | 0.0 | D | |
| H44 | DATA 2 | W | -50.00 to 50.00 | % | 2 | Second correcting value (d2) | 0.0 | D | |
| H45 | FREQUENCY 3 | W | 0 to 32000 | Hz | 0 to 5 | Third break-point frequency (f3) | 0.0 | D | |
| H46 | DATA 3 | W | -50.00 to 50.00 | % | 2 | Third correcting value (d3) | 0.0 | D | |
| H47 | FREQUENCY 4 | W | 0 to 32000 | Hz | 0 to 5 | Fourth break-point frequency (f4) | 0.0 | D | |
| H48 | DATA 4 | W | -50.00 to 50.00 | % | 2 | Fourth correcting value (d4) | 0.0 | D | |
| H49 | FREQUENCY 5 | W | 0 to 32000 | Hz | 0 to 5 | Fifth break-point frequency (f5) | 0.0 | D | |
| H50 | DATA 5 | W | -50.00 to 50.00 | % | 2 | Fifth correcting value (d5) | 0.0 | D | |
| H60 | SELF CHECK | R | GOOD ERROR | | | Self-diagnostic Message | | | |

(*1) : Available for 3.10 or greater version that can be checked in K50.

(8) Item J : Test

These items are for test of output.

A value in "()" is the data corresponding to the indicator.

| Item | Name | R / W | Data Range | Unit | Decimal Point | Remark | Initial Value | Disp. | U / D ^(*) |
|--------------------|--------------|-------|--|------|---------------|-------------------------|---------------|-------|----------------------|
| J00 | TEST | | | | | Menu J (Test) | | | |
| J10 | OUT ANALOG | W | 0.0 to 110.0 | % | 1 | Current Output | 0.0 | D | |
| J20 | OUT PULSE | W | 0 to 10000 | PPS | 0 | Pulse Output | 0 | D | |
| J30 | OUT STATUS | W | OFF (0) ON (1) | | | Status Output | (0) | D | |
| J40 ^(*) | RELEASE TIME | W | 10min (0) 30min (1) 60min (2) 3h (3) 6h (4) 12h (5) | | | Test auto release time | 0 | D | |
| J60 | SELF CHECK | R | GOOD ERROR | | | Self-diagnostic Message | | | |

(*1) : Available for 3.10 or greater version that can be checked in K50.

(*2) : Available for 7.00 or greater version that can be checked in K50.

(9) Item K : Maintenance

These items are for maintenance.

| Item | Name | R / W | Data Range | Unit | Decimal Point | Remark | Initial Value | Disp. | U / D ^(*) |
|--|--------------|-------|--|------|---------------|--|--------------------|-------|----------------------|
| K00 | MAINTENANCE | | | | | Menu K (Maintenance) | | | |
| K10 | TLA | W | 0.1 to 20.0 | | 1 | Trigger Level Adjust | 1.0 | D | |
| K20 | SIGNAL LEVEL | W | 0.1 to 20.0 | | 1 | Signal Level | 1.0 | D | |
| K25 | N.B. MODE | W | AUTO (0) MANUAL (1) TUNING AT ZERO (2) | | | Selection of Noise balance Mode | (0) | D | |
| K26 | NOISE RATIO | R / W | 0.00 to 2.00 | | 2 | Ratio of noise balance | | D | |
| K28 | SET VORTEX F | W | 0 to 10000 | Hz | 0 to 5 | Output test by setting simulated frequency. ^(*) | | D | |
| K30 | VELOCITY | R | | m/s | 2 | Velocity | | D | |
| K32 | SPAN V | R | | Hz | 2 | Span velocity | | D | |
| K34 | VORTEX FREQ. | R | | Hz | 0 to 5 | Vortex frequency | | D | |
| K36 | SPAN F | R | | | 0 to 5 | Span frequency | | D | |
| (Indicate only for F10: Saturated Steam, Superheat Steam, LIQUID: Mass) ^(*) | | | | | | | | | |
| K38 | DENSITY | R | 0.00001 to 32000 | D25 | 0 to 5 | Density value (Calculated by Thermometer) | | D | |
| K40 | ERROR RECORD | R | | | | Error Records | | | |
| K45 | H VIBRATION | W | 0% (0) NO ACTION (1) | | | Selection of Output Function when "High Vibration" error is indicated. | (1) ^(*) | | |
| K50 | SOFTWARE REV | R | 0.01 to 99.99 | | 2 | Software Revision Number | | | |
| K60 | SELF CHECK | R | GOOD ERROR | | | Self-diagnostic Message | | | |

/MV : Multi-Variable (Build-in Temperature Sensor) Type

(*) : Available for 3.10 or greater version that can be checked in K50.

(*) : Available for 5.10 or greater version that can be checked in K50.

(*) : If 7.00 or less version that can be checked in K50, Initial Value is 0.

(10) Item M : Memo

These items are for Memorandum.

| Item | Name | R / W | Data Range | Unit | Decimal Point | Remark | Initial Value | Disp. | U / D ^(*) |
|------|------------|-------|---------------|------|---------------|-----------------------------|---------------|-------|----------------------|
| M00 | MEMO | | | | | Menu M (Memo) | | | |
| M10 | MEMO 1 | W | 16 characters | W | | Memorandum 1 ^(*) | | | |
| M20 | MEMO 2 | W | 16 characters | W | | Memorandum 2 ^(*) | | | |
| M30 | MEMO 3 | W | 16 characters | W | | Memorandum 3 ^(*) | | | |
| M60 | SELF CHECK | R | GOOD ERROR | R | | Self-diagnostic Message | | | |

(*) : Available for 3.10 or greater version that can be checked in K50.

(*) : Available characters are same as C10.

Read Section 6.4 "Parameters Description."

6.4 Parameters Description

(1) Item A : Display

These items are for the indication of flowrate and total.

[A10:FLOW RATE(%)] Flow rate

Flowrate is displayed by “%” to span value.

[A20:FLOW RATE] Flow rate (Engineering unit)

Flowrate is displayed by engineering unit.

[A30:TOTAL] Total value

Total value of flowrate is displayed

Note: There will be linked to the value of B45 TOTAL RATE, it is displayed “E” shows multiplier 10.

Example

| B45 | A30 |
|----------------------------|----------|
| 10000 (= 10 ⁴) | 999999E4 |
| 10 (= 10 ¹) | 999999E1 |
| 0.00001 | 9.99999 |

The following item should be done in case of which Option code /MV is selected and analog output is “Temperature”.

[A40:TEMP(%)] Temperature value

The measured temperature value is displayed by “%” to span value of temperature.

The following item should be done in case of which Option code /MV is selected.

[A41:TEMPERATURE] Temperature value

The measured temperature value is displayed by engineering unit.

(2) Item B : Easy Setting

These items are for the Principal items to operate digital YEW FLO.

A value in “()” is the data corresponding to indicator.

[B10:FLOW SPAN] Flowrate span

Set the required span with a numerical.



NOTE

The range of measurable flow velocity is as described in Table 13.6

[B15:DAMPING] Damping time constant

Set damping time constant values from 0s to 99sec.

[B20:CONTACT OUT] Contact output

Select contact output.

| Item | Description |
|-----------------------|--|
| OFF (0) | _____ |
| SCALED PULSE (1) | Scaled pulse output: Read “B21” |
| UNSCALED PULSE (2) | Unscaled pulse output: Read “B21” |
| FREQUENCY (3) | Frequency output: Read “B22” |
| ALARM (4) | Alarm output: The status goes from close to open (OFF) during alarming. Read Section 6.5 “Self-Diagnostic (Error Code List)”. |
| FLOW SW (LOW:ON) (5) | Status output: Read “B23” |
| FLOW SW (LOW:OFF) (6) | Status output: Read “B23” |

[B21:PULSE RATE] Pulse output rate

Set output rate in a selection of SCALED PULSE or UNSCALED PULSE.

SCALED PULSE OUTPUT:

When SCALED PULSE is selected in B20, set flowrate per one pulse output. Rate unit is linking to the flow unit.

UNSCALED PULSE OUTPUT:

When UNSCALED PULSE is selected in B20, it outputs the pulse calculated by following formula.

The formula for output pulse number is as follows.

Output pulse number per one second = vortex number per one second / PULSE RATE set number.

Read Subsection 10.1.5 “Setting of Pulse Output (Scaling)”.

[B22:FREQ AT 100%] Pulse numbers of 100% at one second

Set pulse number at 100% for one second when "FREQUENCY" in B20 is selected.

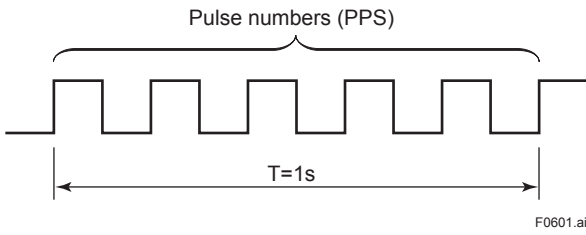

[B23:SET LEVEL] Level of flow switch

Set level of flow switch when "FLOW SW" in B20 is selected. The contact output is sent out when the flowrate is less than the set comparison level.

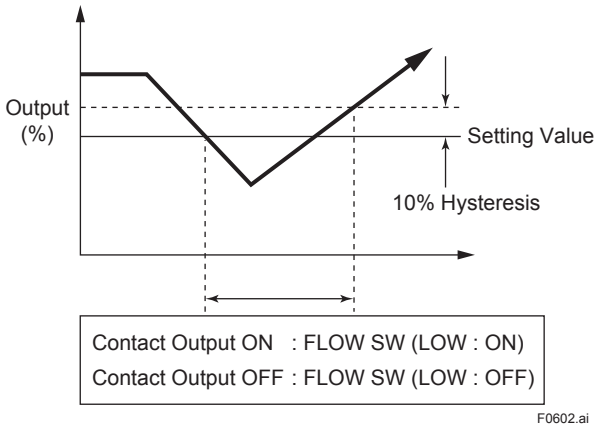

[B30:UPPER DISP] Upper indicator display

Select upper display, Flow rate (%) (0), Flowrate (1), TEMP(%) (2). "TEMP(%)" can be selected when Option Code /MV.

[B31:LOWER DISP] Lower indicator display

Select lower indicator display, "BLANK (0), TOTAL (1), TEMP(2). When "BLANK" in B31 is selected, indicator is blank. "TEMP" can be selected when Option Code /MV.

[B40:TOTAL START]

Select the START/STOP of totalizer from "STOP (0), START (1)."

[B45:TOTAL RATE] Total rate of the totalizer

Set the total rate of the totalizer.

[B47:TOTAL RESET] Reset the totalizer

When totalizer reset function is executed, the total display and communication parameter are reset.

The following items should be done in case of which Option code "/MV" is selected.

[B50 A/OUT SELECT] Analog Output select

Select the analog output select from flow rate or temperature.

When changing the analog output, UPPER DISPLAY can be changed shown as below automatically.

| B50 : A/OUT SELECT | UPPER DISPLAY |
|--------------------|---------------|
| "TEMP" TO "FLOW" | FLOW (%) |
| "FLOW" TO "TEMP" | TEMP (%) |

("B30 : UPPER DISPLAY" is "FLOW RATE", it can not be changed.)

The following item should be done in case of which B50 is "TEMP"

[B51 TEMP 0%] Temperature value of 0% output

Set temperature value of 0% output.

[B52 TEMP 100%] Temperature value of 100% output

Set temperature value of 100% output.

(3) Item C : BASIC SETUP

These items are for the basic parameters with setting before shipment.

The parameters which are set in B are not necessary to set in C.

A value in “()” is the data corresponding to indicator.

The parameters, C20 to C50, are not indicated when option code “/MV” is selected and parameter item is selected in F10 except “Monitor only” or “Not Use”.

[C10: TAG NO] Tag. No

Set Tag. No. (16 characters)

Available characters are as follows.

| |
|---|
| A B C D E F G H I J K L M N O P Q R S T U V W X Y Z a |
| b c d e f g h i j k l m n o p q r s t u v w x y z 0 1 2 3 4 5 6 7 |
| 8 9 . SPACE / - , + *) (' & % \$ # " ! |

F0603.ai

[C20:FLUID] Flowrate unit

Set the flowrate unit below.

| Item | Description |
|------------------------|---|
| LIQUID : Volume (0) | Volumetric flow of liquid measuring |
| GAS/STEAM : Volume (1) | Volumetric flow of gas or steam measuring |
| LIQUID : Mass (2) | Mass flow of liquid measuring |
| GAS/STEAM : Mass (3) | Mass flow of gas or steam measuring |
| GAS : STD/Normal (4) | Volumetric flow at Standard condition |

The following items should be done in case of which “C20” is “LIQUID : Volume” or “GAS/STEAM : Volume”.

[C22:VOLUME UNIT] Volumetric unit

Select the unit of volumetric flow from m³(0), k m³(1), l(2), cf(3), m cf(4), k cf(5), USgal(6), k USgal(7), UKgal(8), k UKgal(9), bbl(10), m bbl(11), k bbl(12).

The following items should be done in case of which “C20” is “LIQUID: Mass” or “GAS/STEAM : Mass”

[C25:DENSITY UNIT] Density Unit of Flow measurement

Select the unit of density from kg/m³(0), lb(1), lb/USgal(2), lb/UKgal(3).

[C26:DENSITY f] Density at normal operation conditions

Set the density value of the fluid at operating condition for mass flow unit.

[C27:MASS UNIT] Mass flowrate unit

Select the mass flowrate unit from kg(0), t(1), lb(2), k lb(3).

The following item should be done in case of which “C20” is “GAS/STEAM : Volume”.

[C30:TEMP UNIT] Fluid temperature unit at operating conditions

Select temperature unit at operating condition from “degC (0), degF (1)”.

[C31:TEMP f] Fluid temperature at operating conditions

Set fluid temperature at operating condition.

The following items should be done in case of which “C20” is “GAS/STD : Normal”.

[C32:TEMP b] Fluid temperature at standard/normal conditions

Set the values of Fluid temperature at standard condition.

[C33:PRESS UNIT] Pressure unit

Select the unit of pressure.

| BRAIN | | HART | |
|--------------------------|--------------------------|-------------|--|
| MPa abs (0) | | MPa abs (0) | |
| kPa abs (1) | | kPa abs (1) | |
| bar abs (2) | kg/cm ² a (2) | bar abs (2) | |
| kg/cm ² a (3) | | psia (4) | |
| psia (4) | | | |

[C34:PRESS f] Absolute pressure at operating conditions

Set the absolute pressure at operating condition.

[C35:PRESS b] Absolute pressure at standard/normal condition

Set the absolute pressure at normal condition.

[C36:DEVIATION] Deviation factor

Set deviation factor.

[C37:STD/NOR UNIT] Volumetric unit at normal conditions

Select volumetric unit at normal condition from Nm³(0), k Nm³(1), M Nm³(2), NI(3), Sm³(4), k Sm³(5), M Sm³(6), SI(7), scf(8), k scf(9), M scf(10).
N: Normal
S: Standard

[C40:TIME UNIT] TIME UNIT

Select time unit from "/s(0), /m(1), /h(2), /d(3)"

[C45:FLOW SPAN] Flowrate span

Set the required span with a numerical value.

[C50:DAMPING] Damping time constant

Set damping time constant values from 0 to 99s.

(4) Item D (AUX. SETUP)

These items are for Auxiliary setup.

A value in "()" is the data corresponding to indicator.

[D10:LOW CUT] Low-cut flowrate**NOTE**

For D10 setting, be sure to set "NOMINAL SIZE" in E10 firstly.

Set to noise elimination or zero flow in the low flowrate (or low frequency) range. The settable range for low cut flowrate is more than half-minimum flowrate.

**NOTE**

In case that Reynolds adjustment (H25), Gas expansion correction (H30) or select a break point correction (H40) is necessary to set, D10: LOW CUT must be set after the items for compensations (H25, H30, H40) are set to "ACTIVE".

[D20:TEMP UNIT] Fluid temperature unit at operating conditions

Select temperature unit at operating condition from deg C (0), deg F (1).

[D21:TEMP f] Fluid temperature at operating conditions

Set fluid temperature at operating condition.

[D25:DENSITY UNIT] Density Unit of Flow measurement

Select the unit of density from kg/m³(0), lb/cf(1), lb/USgal(2), lb/UKgal(3).

[D26:DENSITY f] Density at normal operation conditions

Set the density value of the fluid at operating condition for mass flow unit

[D30:OUT LIMIT] Limit value of output and indication

Set limit value of output from 100.0% to 110.0%

[D35:BURN OUT] Indication of the output direction at burn out

This is indication of the output direction at burn out. Read Subsection 10.1.6 "Setting of Burnout Switch" when the output direction can be changed.

[D40:SPECIAL UNIT] Change to special flowrate unit

No(0) : Off the function

Yes(1) : Convert the flow unit for USER'S UNIT

The factor to convert the flow unit comes from D43. The time unit comes from C40 or F35.

Special(2) : Convert the flow unit and time unit for the USER'S UNIT.

The factor to convert the flow unit and time unit comes from D43.

[D41:BASE UNIT] Indication of the base flowrate unit

Indication of the basic flowrate unit when item D40 is "Yes(1)" or "Special(2)".

[D42:USER'S UNIT] Free unit for users

Set in up to 8 alphanumeric characters when item D40 is "Yes(1)" or "Special(2)".

The character and sign which can be set up are the same as C10.

[D43:CONV FACTOR] Conversion factor

Set the conversion factor when item D40 is "Yes(1)" or "Special(2)".

Set the conversion factor which is for both flow unit and time unit in case of "Special(2)".

(5) Item E (METER SETUP)

These items are for detector set up that has already been set before shipment.

A value in “()” is the data corresponding to indicator.

[E10:NOMINAL SIZE] Nominal size of the detector

Select the nominal size of the flowmeter, from 15mm(0), 25mm(1), 40mm(2), 50mm(3), 80mm(4), 100mm(5), 150mm(6), 200mm(7), 250mm(8), 300mm(9), or 400mm(10).

[E20:BODY TYPE] Body type for the detector

Select body type for detector from standard or high pressure.

- Standard (0) : Standard type
- High Pressure (1) : High Pressure type (TOKUCHU)
- Low Flow Unit (1) (2) : Reduced Bore type (option code: /R1)
- Low Flow Unit (2) (3) : Reduced Bore type (option code: /R2)



NOTE

Parameter setting for the Reduced Bore type, Select Low Flow Unit (1) or (2) and set. Set nominal size of the model code to E10: NOMINAL SIZE.

[E30:SENSOR TYPE] Sensor type for the detector

Select sensor type for the detector from standard, /HT, or /LT.

- Standard (0) : Standard type
- High Temperature (1) : High Process Temperature Version
- Low Temperature (2) : Cryogenic Version

[E40:K-FACTOR UNIT] K-factor unit

Select this unit from p/l, p/USgal, p/UKgal.



IMPORTANT

K-FACTOR is the eigenvalue of each detector. Please keep the factory preset value. NEVER REWRITE IT. (Unless the replacement of the remote type detector.)

[E41:K-FACTOR] K-factor

The flowmeter name plate includes a K-factor (KM) at 15°C for the combined detector.

[E50:DETECTOR NO.] Detector number of flowmeter

Set the serial number using 16 alphanumeric characters of the detector combined converter.

(6) Item F (Thermometer)

These items are for setting of thermometer and available when build in thermometer type (Option code: /MV).

[F10: Function] Thermometer function

Select the thermometer function.

- Monitor only (0): Only temperature measurement.
- Saturated Steam (1): Mass Flow rate is calculated from density values by temperature measurement using saturated steam table.
- Superheat Steam (2): Mass Flow rate is calculated from density values by temperature measured by using steam table. In order to measure superheat steam. It is necessary to make constant pressure value.
- GAS: STD/Normal (3): Volumetric flow rate at standard condition is calculated by using Pressure- Temperature correction. It is necessary to male constant pressure value.
- LIQUID: Mass (4): Mass flow rate is calculated by using the density change values depend on temperature values by which the secondary order function is used.

The following item should be done in case of which F10 is Saturated steam

[F12 MASS UNIT] Mass flow unit

Select mass rate unit from kg(0), t(1), lb(2), k lb(3).

The following items should be done in case of which F10 is Superheat steam

[F14 PRESS UNIT] Pressure unit

Select pressure unit from MPa abs(0), kPa abs(1), bar abs(2), kg/cm² a(3), psia(4).

[F15 PRESS f] Pressure value

Set absolute pressure values at operating condition.

[F16 MASS UNIT] Mass flow unit

Select mass flow unit from kg(0), t(1), lb(2), k lb(3).

The following items should be done in case of which F10 is GAS: STD/Normal

[F18 TEMP UNIT] Temperature unit

Select temperature unit from deg C(0), deg F (1).

[F19 TEMP b] Temperature b

Set temperature value at normal/standard condition.

[F20 PRESS UNIT] Pressure unit

Select pressure unit from MPa abs(0), kPa abs(1), bar abs(2), kg/cm² a(3), psia(4).

[F21 PRESS f] Pressure value f

Set absolute pressure values at operating condition.

[F22 PRESS b] Pressure value b

Set absolute pressure values at normal/standard Condition.

[F23 DAVIATION] Daviation factor

Set the daviation factor.

[F24 STD/NOR UNIT] Standard/Normal unit

Select Volumetric unit at standard/normal condition
From Nm³(0), k Nm³(1), M Nm³(2), NI(3), Sm³(4)
k Sm³(5), M Sm³(6), SI(7), scf(8), k scf(9), M scf(10)
N: Normal
S: Standard

The following item should be done in case of which F10 is LIQUID:MASS

[F26 DENSITY UNIT] Density unit

Select density unit from kg/m³(0), lb/cf(1), lb/USgal(2), lb/UKgal(3).

[F27 DENSITY b] Density b

Set density value at standard condition.

[F28 TEMP UNIT] Temperature unit

Select temperature unit from deg C(0), deg F(1).

[F29 TEMP b] Temperature b

Set temperature value at standard condition

[F30 1st coef] 1st coefficient

Set 1st temperature coefficient using the density correction.

[F31 2nd coef] 2nd coefficient

Set 1st temperature coefficient using the density correction.

[F32 MASS UNIT] Mass unit

Select mass flow rate unit from kg(0), t(1), lb(2), k lb(3).

[F35 TIME UNIT] Time unit

Select time unit from /s(0), /m(1), /h(2), /d(3).

[F40 FLOW SPAN] Flow span

Set span flow rate, 0 to 32000.

[F45 DAMPING] Flow damping

Set flow damping, 0 to 99sec.

[F50 TEMP DAMPING] Temperature damping

Set temperature damping, 0 to 99sec.

[F52 CABLE LENGTH] Cable length of signal cable(DYC)

Set cable length(m) of signal cable.

In case of the integral type, cable length is set in 0m.

**IMPORTANT**

Be sure to set this parameter to correct temperature measurement error, occurred by cable length.

[F55 A/OUT SELECT] Analog out select

Select the analog output from FLOW(0), TEMP(1).

The following item should be done in case of which F55 is TEMP

[F56 TEMP 0%] Temperature at 0%

Set temperature value at 0%.

[F57 TEMP 100%] Temperature at 100%

Set temperature value at 100%.

[F58 TEMP ERR OUT] Output selection of thermometer error

Select output function when thermometer error from 0%(0), OUTLIMIT(H)(1), TEMP f.

In case of OUT LIMIT(H), it is based on parameter "D30"

(7) Item H (ADJUST)

This item for setting of adjustment.



NOTE

In case that Reynolds adjustment (H25), Gas expansion correction (H30) or select a break point correction (H40) is necessary to set, D10: LOW CUT must be set after the items for compensations (H25, H30, H40) are set to "ACTIVE".

[H10, H11:TRIM 4mA, TRIM 20mA] Trimming of 4mA and 20mA

Fine tuning adjustment of 4mA and 20mA output. Fine tuning range is form -1.00% to 1.00%.

[H20:USER ADJUST] Conversion factor for user setting.

Set conversion factor by user. This conversion factor is converted into measurement flowrate.

[H25:REYNOLDS ADJ] Reynolds adjustment

Select the Reynolds adjustment. This adjustment should be done in case of their error compensation, because error of vortex flowmeter should be increased when it come to low reynolds numbers.

NOT ACTIVE(0): Not correction calculation

ACTIVE(1): Correction calculation

The following item should be set in case of which "H25" is "ACTIVE".

[H26:DENSITY f] Density at operating condition

Set the density at operating condition.

[H27:VISCOSITY] Viscosity at standard condition

Set the value of viscosity at standard conditions.

The values should be used for Reynolds adjustment.

Reynolds number(Re) is calculated as shown in the formula below.

$$Re = 354 \times \frac{Q \times \rho_f}{D \times \mu}$$

Q: Volumetric flow (m³/h)

D: Internal diameter (mm)

ρ_f: Density at operating condition

μ: Viscosity (m Pa · s (cp))

Flowrate error of vortex flowmeter increases as Reynolds number decrease less than 20000. By setting H25, H26, H27, it corrects the error.

[H30:EXPANSION FA] Gas expansion correction.

When measuring a compressibility gas by mass flow (Steam M, Gas M) and standard condition (Gas Qn), this expansion factor is useful to correct the deviation from the ideal gas law.

[H40:FLOW ADJUST] Select a break point correction

Select a break point correction for the instrumental error from "NOT ACTIVE(0)" or "ACTIVE(1)".

[H41 to H50] Instrumental Error Correction

- Correct the instrumental error in flowmeter characteristics using 1 line-segment approximation (with five correction factors).
- (1) Flow frequency input at line segments needs to be f₁≤f₂≤f₃≤f₄≤f₅.
When four correction factors are available, line segments need to be f₄=f₅ and d₄=d₅.
When three correction factors are available, line segments need to be f₃=f₄=f₅ and d₃=d₄=d₅.
- (2) When a flow input of f₁ or less is present, correct the instrumental error as the corrected value=d₁.
- (3) When a flow input of f₅ or more is present, correct the instrumental error as the corrected value=d₅.
- (4) Abscissa (f₁ to f₅) : Set the break-point frequencies as parameters.
- (5) Ordinate (d₁ to d₅) : Set the corrected value (%) at each break-point as parameters.

$$\text{Set value} = - \frac{Q_s - I}{I} \times 100$$

Where

Q_s : Correct flowrate determined by a reference apparatus

I : Indication of vortex flowmeter

- Definition of error varies with the type of flowmeter. Be careful of the difference in signs in the error and corrected value.

$$Q_f = \frac{f(\text{Hz})}{K\text{-factor}} \times 100$$

holds and the error is included in the K-factor. Therefore, for the region where the K-factor shift on the positive side, the corrected value is negative.

The corrected value when the calibration fluid of the flowmeter and the fluid to be measured are different must be set as a corrected value obtained by making both abscissas agree with respect to the Reynolds number.

(8) Item J (TEST)

These items are for test of output.

A value in “()” is the data corresponding to indicator. The test output by setting in J10, J20 or J30 is automatically released when shifts from these parameter items or as following time goes without access to these parameter items.

“K50: SOFTWARE REV” = “6.20” or less: 10 minutes

“K50: SOFTWARE REV” = “7.00” or greater: a value set in J40: RELEASE TIME

[J10:OUT ANALOG] 4 to 20mA Current output

It tests 4 to 20mA Current output. Electric current of the set value (%) which designates 4 to 20mA as 0 to 100%.

When this test is executed, transistor contact output (Pulse, Alarm, Status) is fixed at ON or OFF (not determined).

[J20:OUT PULSE] Pulse output

It tests Pulse output.

The number of pulses which is set (unit: PPS) is output.

Exiting this parameter item or stopping access after ten minutes which is set in J40, this function will be reset automatically.

When this test is executed, current output is fixed at 0% (4mA).

[J30:OUT STATUS] Status output test

Status output test can be executed (OFF(0) or ON(1)).

When this test is executed, current output is fixed at 0% (4mA).

Exiting this parameter item or stopping access after ten minutes, this function will be reset automatically.

[J40:RELEASE TIME] Release time

Automatic reset time of J10, J20 and J30 can be change.

Select from 10min (0), 30min (1), 60min (2), 3h (3), 6h (4), or 12h (5).

(9) Item K (Maintenance)

These items are for maintenance.

A value in “()” is the data corresponding to indicator.

[K10:TLA] TLA Adjustment

Trigger level (TLA) is adjusted upon shipment.

Therefore, TLA adjustment is nonnecessity. But set TLA adjustment below as

- The measurement of Low flow rate area is required.
- Mechanical vibration and impact are applied to digitalYEWFO and Zero point and low flow rate area is output.

Note: Read Section 10.2 “Adjustment for Manual Mode”.

[K20:SIGNAL LEVEL] Signal Level

Set the signal level.

[K25:N. B. MODE] Noise Balance Mode

Set the Noise Balance Mode from “AUTO(0)”, “MANUAL(1)”, or “TUNING AT ZERO(2)”

[K26:N. B.RATIO] The ratio of Noise Balance

When “NOISE BALANCE MODE (N. B. MODE)” is “AUTO”, noise balance value is the indication only.

When N.B. mode is “MANUAL”, the noise balance can be adjusted entering the setting values.

Note: Read Section 10.2 “Adjustment for Manual Mode”.

[K28:SET VORTEX F] Output test by setting simulated frequency

Amplifier check is executed by simulated frequency input.

Output to be able to check are, analog output, pulse output/contact output.

Test status also can be seen on display board.

**NOTE**

- In case of multi-variable type (option code: /MV), output value is calculated by setting density and temperature.
- Available for 5.10 or greater version that can be checked in K50 SOFTWARE REV.

[K30:VELOCITY] Flow velocity

Indication of flow velocity at the operating conditions.

[K32:SPAN V] Flow span velocity

Indication of flow span velocity.

When /MV is selected and "F10 : FUNCTION" is "Saturated Steam" or "Superheat Steam" and "GAS : STD/Normal" or "LIQUID : Mass", the display of span velocity may differ from an actual value.

[K34:VORTEX FREQ.] Vortex frequency.

Indication of vortex frequency at operating conditions.

[K36:SPAN F] Span vortex frequency.

Indication of span vortex frequency.

When /MV is selected and "F10 : FUNCTION" is "Saturated Steam" or "Superheat Steam" and "GAS : STD/Normal" or "LIQUID : Mass", the display of span frequency may differ from an actual value.

[K40:ERROR RECORD] Error record

The error record can be indicated.

- The error is recorded as history.
- The error history is not time-series data.
- The error history can be holded for 30 days.

In order to clear an error record, set the video inverse bar by "< >" and press "ENTER"key twice.

[K45:H VIBRATION] Selection of output operation

Select the output operation when "High Vibration" in self-diagnosis.

[K50:SOFTWARE REV] Software revision

The software revision can be indicated.

6.5 Self-Diagnostic (Error Code List)

When an ERROR is displayed by SELF CHECK in item A60, B60, C60, D60, E60, H60, J60, K60 or M60, press function key F2 [DIAG] and the error contents are displayed.

| Indication | Diagnostic Message | Error Name | Problem Cause | Current Output | | % Output | | Pulse Output | Engineering Unit Output | Totalizing Output | Engineering Temp Output | Pulse / Status Output | | How to recover | |
|-----------------------|--------------------|-------------------------------------|--|---|---|---|---|---|---|---|--|---|-----------------------|--|---|
| | | | | Select flow rate | Select temperature | Select flow rate | Select temperature | | | | | Pulse ^(*) | Status ^(*) | | Alarm ^(*) |
| Err-01 | FLOW OVER OUTPUT | Over range output signal | Output signal is 110% or more ^(*) | Fixed at 110% ^(*) | Normal Operation | Fixed at 110% ^(*) | Normal Operation | Normal Operation | Normal Operation | Normal Operation | Normal Operation | Normal Operation | OFF(H) | Change parameters or over ranged flow input | |
| Err-02 | SPAN SET ERROR | Span Setting Error | Span setting parameter is more than 1.5 times of max flow velocity | Normal Operation | Normal Operation | Normal Operation | Normal Operation | Normal Operation | Normal Operation | Normal Operation | Normal Operation | Normal Operation | OFF(H) | Change parameters span factor is outside the acceptable limits | |
| Err-06 | PULSE OUT ERROR | Pulse output error | Pulse output frequency is more than 10kHz | Normal Operation | Normal Operation | Normal Operation | Normal Operation | Fixed at 10kHz | Normal Operation | Normal Operation | Normal Operation | Normal Operation | | Change parameters (ItemC, ItemE) | |
| Err-07 | PULSE SET ERROR | Pulse setting error | Pulse output frequency setting is more than 10kHz | Normal Operation | Normal Operation | Normal Operation | Normal Operation | Normal Operation | Normal Operation | Normal Operation | Normal Operation | Normal Operation | | Change parameters (ItemC, ItemE) | |
| CHECK Vibration | Transient noise | Error of Vibration | Transitional disturbance | Hold | Normal Operation | Normal Operation | Normal Operation | Normal Operation | Hold | Normal Operation | Normal Operation | Normal Operation | OFF(H) | CHECK the vibration | |
| CHECK Vibration | High vibration | Error of Vibration | High vibration | Based on K45 | Normal Operation | Normal Operation | Normal Operation | Based on K45 | Normal Operation | Stop the total | Normal Operation | Normal Operation | OFF(H) | CHECK the vibration | |
| CHECK Flow | Fluctuating | Error of Flow | Fluctuating | Normal Operation | Normal Operation | Normal Operation | Normal Operation | Normal Operation | Normal Operation | Normal Operation | Normal Operation | Normal Operation | OFF(H) | CHECK the dlogging | |
| CHECK Flow | Clogging | Error of Flow | Clogging | Normal Operation | Normal Operation | Normal Operation | Normal Operation | Normal Operation | Normal Operation | Normal Operation | Normal Operation | Normal Operation | OFF(H) | CHECK the dlogging | |
| Err-10 ^(*) | TEMP OVER OUTPUT | Over range Temp output signal | Temp output signal is 110% or more, and 0% below. | Normal Operation | Fixed at 110% in case of over 110%, and fixed at 0% when in case of less than 0% ^(*) | Normal Operation | Fixed at 110% in case of over 110%, and fixed at 0% when in case of less than 0% ^(*) | Normal Operation | Normal Operation | Normal Operation | Normal Operation | Normal Operation | Normal Operation | OFF(H) | CHECK the temperature or temperature span |
| Err-11 ^(*) | OVER TEMP | Error of temperature | Temp value is -50°C below or 300°C over. | Remain in operation at Temp=50°C or Temp=300°C | Remain in operation at Temp=50°C or Temp=300°C | Remain in operation at Temp=50°C or Temp=300°C | Remain in operation at Temp=50°C or Temp=300°C | Remain in operation at Temp=50°C or Temp=300°C | Remain in operation at Temp=50°C or Temp=300°C | Remain in operation at Temp=50°C or Temp=300°C | Remain in operation at Temp=50°C or Temp=300°C | Remain in operation at Temp=50°C or Temp=300°C | OFF(H) | CHECK the temperature | |
| Err-12 ^(*) | TEMP SENSOR FAULT | Error of thermometer | Disconnection or short of thermometer sensor | Remain in operation at Manual setting condition | Based on F58 | Remain in operation at Manual setting condition | Based on F58 | Remain in operation at Manual setting condition | Remain in operation at Manual setting condition | Remain in operation at Manual setting condition | Based on F58 | Remain in operation at Manual setting condition | OFF(H) | Change thermometer sensor. | |
| Err-13 ^(*) | TEMP CONV. FAULT | Error of temperature converter | Temperature converter is failed | Remain in operation at Manual setting condition | Based on F58 | Remain in operation at Manual setting condition | Based on F58 | Remain in operation at Manual setting condition | Remain in operation at Manual setting condition | Remain in operation at Manual setting condition | Based on F58 | Remain in operation at Manual setting condition | OFF(H) | Change converter case build in temperature sensor. | |
| Err-20 | PRE-AMP ERROR | PRE-AMP is failed | | Normal Operation | Remain in operation at Manual Setting Temperature Value | Normal Operation | Remain in operation at Manual Setting Temperature Value | Normal Operation | Normal Operation | Normal Operation | Remain in Manual Setting Temperature Value | Normal Operation | OFF(H) | Replace the AMP unit | |
| Err-30 | EE PROM ERROR | EEPROM is not functioning correctly | | Over 110% or -2.5% below | Over 110% or -2.5% below | Over 110% or -2.5% below | Over 110% or -2.5% below | Fixed at 0% | Fixed at 0% | Fixed at 0% | Fixed at 0% | Fixed at 0% | OFF(H) | Replace the AMP unit | |
| Err-40 | FLOW SEBSOR FAULT | Error of Flow sensor | Flow sensor is fault. | Normal Operation | Normal Operation | Normal Operation | Normal Operation | Normal Operation | Normal Operation | Normal Operation | Normal Operation | Normal Operation | OFF(H) | Change Flow sensor | |
| | CPU FAULT | CPU is failed | All operations are Dead. Display and self diagnostic function is also dead.g | Over 110% or -2.5% below | Over 110% or -2.5% below | Over 110% or -2.5% below | Over 110% or -2.5% below | Halt | Halt | Halt | Halt | Halt | Halt | Replace the AMP unit | |

Note: Normal Operation : Operation continues without relation to error occurrence.
 Remain in Operation : Calculation continues with relation to error occurrence.
 (*1): "110%" is based on "D30 : OUT LIMIT(H)".
 (*2): Pulse output : These conditions should be done in case of which B20 is "SCALED PULSE", "UNSCALED PULSE", "FREQUENCY".
 Status output : These conditions should be done in case of which B20 is "FLOW SW (LOW : ON)", "FLOW SW (LOW : OFF)".
 Alarm output : These conditions should be done in case of which B20 is "Alarm".
 (*3): Only for /M/

7. OPERATION FOR THE BRAIN TERMINAL (BT200)

This chapter describes the operation procedures using a BRAIN TERMINAL (BT200). For details on the functions of the digitalYEWFLOW, read Chapter 6 "PARAMETERS." List. And also, read the "Model BT200 BRAIN TERMINAL" Instruction Manual (IM 01C00A11-01E) for more detailed Information.

7.1 Connection Method for the BT200

(1) Connecting the BT200 to a 4 to 20mA DC Transfer Line

The communication signal of the digitalYEWFLOW is superimposed onto the 4 to 20mA DC analog signal to be transferred.

In case of general type (non-ex) and flameproof type:
digitalYEWFLOW

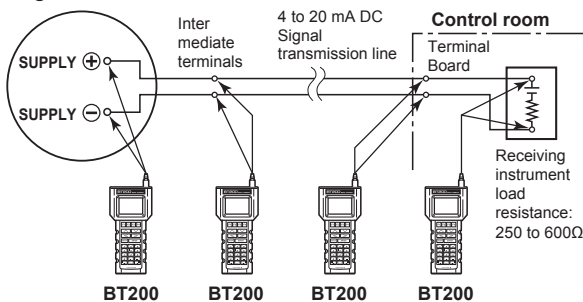

In case of intrinsically safe type:
digitalYEWFLOW

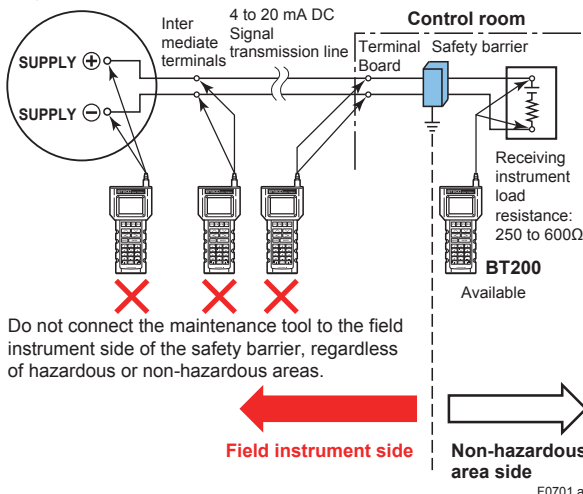

Figure 7.1 Communicating for a 4 to 20mA DC Signal Line



IMPORTANT

Communication signal is superimposed on analog output signal. It is recommended to set a low-pass filter (approximately 0.1s) to the receiver in order to reduce the output effect from communication signal. Before online-communication, confirm that communication signal does not give effect on the upper system.



IMPORTANT

The communicable distance of the transmission line is restricted depending on the wiring method. Read Chapter 4 "WIRING."



IMPORTANT

After setting a parameter, keep the power on for at least 30 seconds. If the power of flowmeter is turned off, a parameter setting is released.

(2) Connection of BT200 to Flow Converter

Removing a cover and indicator, the terminals for BRAIN communication are provided on the circuit board.

Connect BT200 to the terminal of HHT-COM on the circuit board.

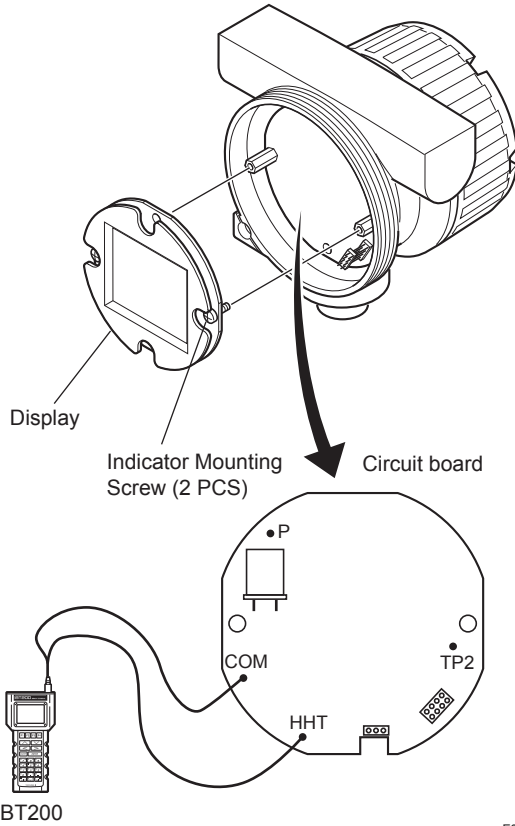
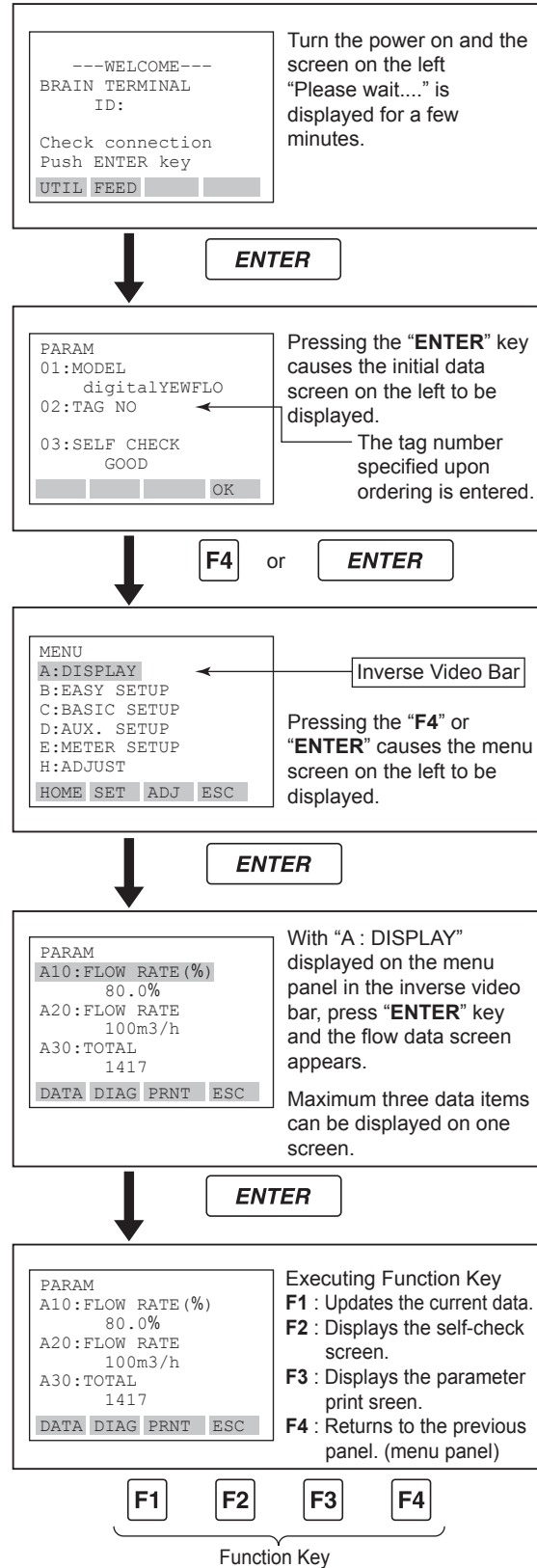

Figure 7.2 Connection of BT200 to Flow Converter

7.2 BT200 Screen and Displaying Flow Rate

Flowrate data can be displayed on the BT200 screen according to the following procedure.



F0703.ai

● Function key

The functions of the function keys vary with the commands being displayed on the display panel.

Table 7.1 Function Command List

| Command | Function |
|-----------|---|
| ADJ | Displays the ADJ menu |
| CAPS/caps | Selects uppercase or lowercase |
| CODE | Selects symbols |
| CLR | Erases input data or deletes all data |
| DATA | Updates parameter data |
| DEL | Deletes one character |
| DIAG | Calls the self-check panel |
| ESC | Returns to the most recent display |
| HOME | Displays the menu panel |
| NO | Quits setup and returns to the previous display |
| OK | Proceeds to the next panel |
| PRAM | Enters the parameter number setup mode |
| SET | Displays the SET menu |
| SLOT | Returns to the slot selection panel |
| UTIL | Calls the utility panel |
| COPY* | Prints out parameters on display |
| FEED* | Paper feed |
| LIST* | Lists all parameters in the menu |
| PON/POFF* | Automatic printout mode on or off |
| PRNT* | Changes to the print mode |
| GO* | Starts printing |
| STOP* | Cancel printing |

*Available on BT200-P00 (with printer).

7.3 Setting Parameters using BT200

This section describes the setting method using a BRAIN TERMINAL (BT200). For details on the method, read Section 6.3 "Parameters List" and Section 6.4 "Parameters Description".

(1) Setting Flow Span

Example : Change flow span 100m³/h to 150m³/h

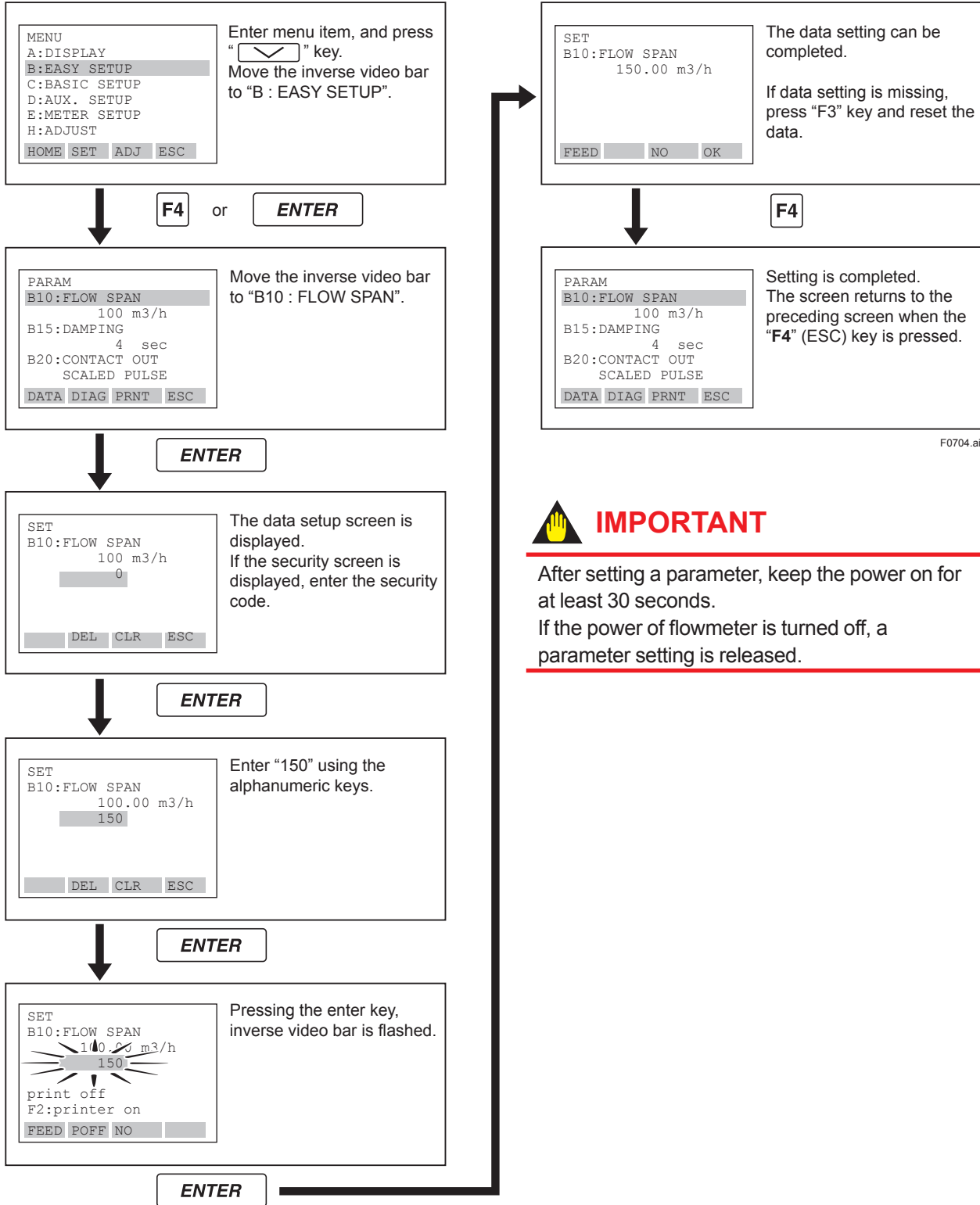

(2) Setting Output

Example: Change the pulse output to alarm output

```

MENU
A:DISPLAY
B:EASY SETUP
C:BASIC SETUP
D:AUX. SETUP
E:METER SETUP
H:ADJUST
HOME SET ADJ ESC

```

Enter menu item, and press "V" key. Move the inverse video bar to "B : EASY SETUP".

ENTER

```

PARAM
B10:FLOW SPAN
      100 m3/h
B15:DAMPING
      4 sec
B20:CONTACT OUT
      SCALED PULSE
DATA DIAG PRNT ESC

```

Item B menu is displayed.

V 2 Times

```

PARAM
B10:FLOW SPAN
      100 m3/h
B15:DAMPING
      4 sec
B20:CONTACT OUT
      SCALED PULSE
DATA DIAG PRNT ESC

```

Move the inverse video bar to "B20 : CONTACT OUT".

ENTER

```

SET
B20:CONTACT OUT
  SCALED PULSE
< OFF >
< SCALED PULSE >
<UNSCALED PULSE>
ESC

```

Pressing "ENTER", cause the data setup screen to be displayed. If the security screen appears, enter the security code.

V 4 Times

```

SET
B20:CONTACT OUT
  SCALED PULSE
<UNSCALED PULSE>
  FREQUENCY
< ALARM >
ESC

```

Move the inverse video bar to "ALARM".

ENTER

```

SET
B20:CONTACT OUT
  SOLID PULSE
  ALARM
Print off
F2:printer on
FEED POFF NO

```

Pressing the enter key, inverse video bar is flashed.

ENTER

```

SET
B20:CONTACT OUT
  ALARM
FEED NO OK

```

The data setting can be completed. If data setting is missing, press "F3" key and rewrite the data.

F4

```

PARAM
B10:FLOW SPAN
      100 m3/h
B15:DAMPING
      4 sec
B20:CONTACT OUT
      ALARM
DATA DIAG PRNT ESC

```

Setting is completed. The screen returns to the preceding screen when the "F4" (ESC) key is pressed.

F0705.ai



IMPORTANT

After setting a parameter, keep the power on for at least 30 seconds. If the power of flowmeter is turned off, a parameter setting is released.

8. OPERATION VIA HART CONFIGURATION TOOL (HART 5)



In this User's Manual, HART protocol revision 5 and 7 are described as HART 5 and HART 7 respectively.

Note: HART is a registered trademark of the HART Communication Foundation (HCF).

8.1 HART Protocol Revision

For the models with the output signal code “-J”, HART protocol revision 5 or 7 is selectable. The protocol revision is set as specified in the order.

- Confirmation by the name plate
The HART protocol revision is shown by the last number of the serial number.

In the case of the communication code “-J”

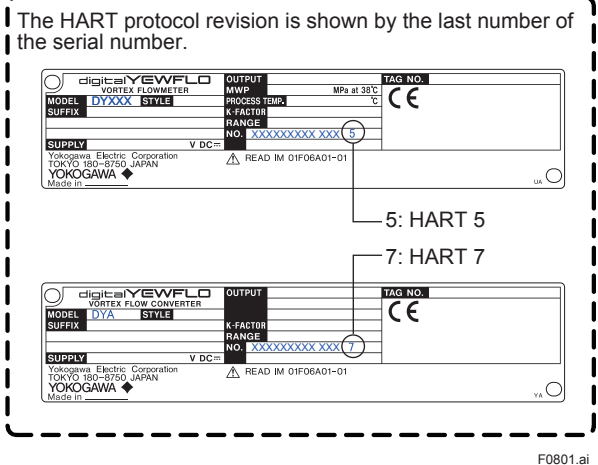

Figure 8.1 Name Plate

8.2 HART Configuration Tool and Matching of Device Revision

Before using the HART Configuration Tool (such as FieldMate), confirm that the DD (Device Description) of the digitalYEWFL0 is installed in the Configuration Tool before using.

DY and DYA HART 5

Device type: 0x37, Device revision: 3 or 4



Protocol revision supported by HART configuration tool must be the same or higher than that of the digitalYEWFL0.

| | Protocol Rev. supported by HART configuration tool | |
|------------------|--|-----------|
| | 5 | 7 |
| DY or DYA HART 5 | Available | Available |
| DY or DYA HART 7 | Not available | Available |

The DD revisions for digitalYEWFL0 and Configuration Tool's can confirm in accordance with the following steps.

If the correct DD is not installed in the HART Configuration Tool, download them from the official HART programming sites, otherwise, contact the respective vendors of the Configuration Tool for its upgrade information.

- Confirmation of the device revision for digitalYEWFL0
Procedure to call up the field device revision [Root Menu] → Review → Review1 'Fld dev rev' in the Review1 shows the revision number of correspondent field device.
- Confirmation of the device revision for the HART Configuration Tool

- Confirm the installed DD revision in accordance with the procedure of the Configuration Tool. Read its manual how to confirm it in detail.

The first 2 digits of the DD file are expressed the device revision, and its last 2 digits are expressed the DD revision.

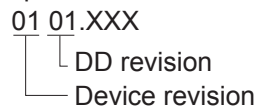

F0802.ai

8.3 Setting Parameters using DTM

When configure the parameters using FieldMate, use the DTM (Device Type Manager) by reading the following table.

| DTM Name | Device Type | Device Revision |
|----------|-------------|-----------------|
| DYF V3.1 | 0 x 37 | 3 |
| DYF V4.1 | 0 x 37 | 4 |

8.4 Interconnection between digitalYEWFO and HART Configuration Tool

The HART Configuration Tool can interface with the digitalYEWFO from the control room, the digitalYEWFO site, or any other wiring termination point in the loop, provided there is a minimum load resistance of 250 Ω between the connection and the receiving instrument. To communicate, it must be connected in parallel with the digitalYEWFO, and the connections must be non-polarized. Figure 8.2 illustrates the wiring connections for a direct interface at the digitalYEWFO site. The HART Configuration Tool can be used for remote access from any terminal strip as well.



WARNING

Be sure to set parameters as “Protect” on the write protect function after finish of parameter setting work. Read Section 8.9 “Software Write Protect” how to use the write protect function in detail.



IMPORTANT

If the power of flowmeter is turned off within 30 seconds after parameters have been set, these settings will be canceled. Accordingly, please keep the power on for at least 30 seconds after setting parameters.



NOTE

Before updating any setting, remember to always check the data content you want to change as described in Section 6.4 “Parameters Description”.

In case of general type (non-ex) and flameproof type:

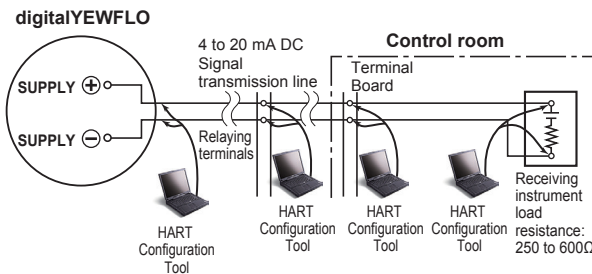

In case of intrinsically safe type:

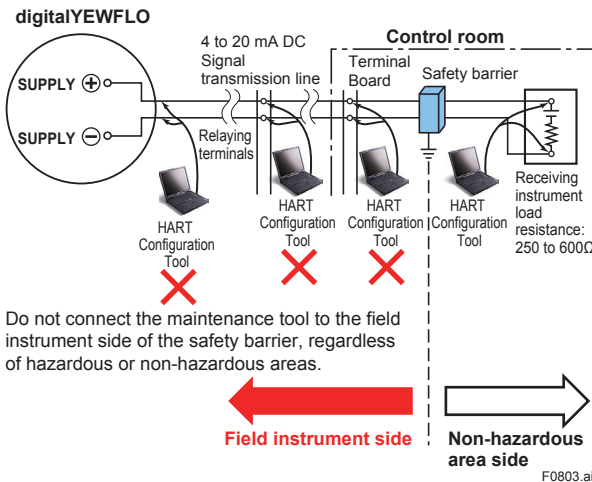

Figure 8.2 Connecting the HART Communicator

8.5 Basic Setup

■ Tag and Device Information

The tag number and device information can be checked as follows:

- The location for the tag number and device information

| Item | Precedure |
|------------|--|
| Tag | [Root Menu] → Basic setup → Tag |
| Descriptor | [Root Menu] → Detailed setup → Device information → Descriptor |
| Message | [Root Menu] → Detailed setup → Device information → Message |
| Date | [Root Menu] → Detailed setup → Device information → Date |

When changing the tag number or device information, enter the information directly within the following limitations.

| Item | Number and characters |
|------------|---|
| Tag | 8 *1 |
| Descriptor | 16 *1 |
| Message | 32 *1 |
| Date | 2/2/2 (mm/dd/yy) • mm : month • dd : day • yy : year |

*1: All characters in the following table can be used.

| | | | | | | | | | | | | | | | |
|-------|---|---|---|----|---|---|---|---|---|---|---|---|---|---|---|
| SPACE | ! | " | # | \$ | % | & | ' | (|) | * | + | , | - | . | / |
| 0 | 1 | 2 | 3 | 4 | 5 | 6 | 7 | 8 | 9 | : | ; | < | = | > | ? |
| @ | A | B | C | D | E | F | G | H | I | J | K | L | M | N | O |
| P | Q | R | S | T | U | V | W | X | Y | Z | [| \ |] | ^ | _ |

F0804.ai

8.6 Parameter Setting

The parameter structure of the HART configuration tool is hierarchical.

Read Section 8.11 “Menu Tree (HART 5)” for the corresponding parameters. The menu tree shows a cross-reference of the parameters for HART configuration Tool and BRAIN Terminal.

Read Section 6.4 “Parameters Description” for the functions of parameters.

Note that some display parameters of digitalYEWFL0 are different from those of HART Configuration Tools.

8.7 Data Renewing and Upload/Download function

- (1) Data renewing
Following data are renewed in 0.5 to 2 seconds cycle.
PV, PV%, rngc, PVAO1, Total
Temp, TV% rngc, AO3: only for /MV
- (2) Upload/download function
Upload/download parameters from digitalYEWFL0 to the HART Configuration Tool.
Read Section 8.11 “Menu Tree (HART 5)” for the applicable parameters.

8.8 Self-Diagnostic

The self-diagnostic function of the digitalYEWFL0 is explained in Section 6.5 “Self-Diagnostic (Error Code List)”.

It is also possible to carry out this function via HART Configuration Tool.

Procedure to call up ‘Self test/Status’;

[Root Menu] → Diag/Service → Self test/Status *(M)
(M): METHOD

METHOD is a program to facilitate the parameter settings.

8.9 Software Write Protect

digitalYEWFL0 configured data is saved by using a write protect function. The write protect status is set to “Yes” when 8 alphanumeric characters are entered in the **New password** field and transferred to the device. When write protect is set to “Yes,” the device does not accept parameter changes. When the same eight alphanumeric string entered in the **New password** field is also entered in the **Enable wrt 10min** field and transferred to the digitalYEWFL0, it will be possible to change the device parameters during a 10 minute period. To change the digitalYEWFL0 from the write protect “Yes” status back to Write protect “No” status, use **Enable wrt 10min** to first release the write protect function and then enter eight spaces in the **New password** field.

8.10 Specific Functions of HART Configuration Tool

8.10.1 Burst Mode

digitalYEWFL0 continuously sends the data via HART Configuration Tool when the burst mode is set on. The data is sent intermittently as a digital signal at 3 times a second.

Procedure to call up 'Burst option' and 'Burst mode';

- (1) Setting the data to be sent
 - [Root Menu] → Detailed Setup → Configure outputs → HART Output → **Burst option**
 - Select the type of data to be sent from the following options:
 - Instantaneous flow rate (PV)
 - Output in % and current output (% range/ current)
 - Current output, PV, SV, TV, QV
- (2) Setting the burst mode
 - [Root Menu] → Detailed Setup → Configure outputs → HART Output → **Burst mode**
 - Then, select "On" at the menu to start the burst mode.
 - To release from the burst mode, call up the burst mode display, and set to "Off."
 - The default setting is "Off."

8.10.2 Multidrop Mode

"Multidropping" devices refers to the connection of several devices to a single communications transmission line. Up to 15 devices can be connected when set in the multidrop mode. To activate multidrop communication, the device address must be changed to a number from 1 to 15. This change deactivates the 4 to 20 mA analog output, sending it to 4 mA. The alarm current is also disabled.

- (1) Polling address
 - Procedure to call up the display

| | |
|--------------|--|
| DD (HART 5) | [Root Menu] → Detailed setup → Configure outputs → HART output → |
| DTM (HART 5) | Configuration → HART → |
| → Poll addr | Enter the number from 1 to 15 |

- (2) Enabling the Multidrop Mode
About the procedure to call up the **Polling** display, please read the User's Manual of each configuration tool.



NOTE

When the same polling address is set for two or more devices in multidrop mode, communication with these devices are disabled.

- (3) Communication when set in multidrop mode.
 - The HART configuration tool searches for a device that is set in multidrop mode when it is turned on. When the HART configuration tool is connected to the device, the polling address and the tag will be displayed.
 - Select the desired device. After that, normal communication to the selected device is possible. However, the communication speed will be slow.

To release multidrop mode, call up the **Poll addr** display and the address to "0".

8.10.3 Switching HART Protocol Revision

When the output signal code is "-J", HART protocol revision of device can be selectable from 5 or 7. The HART protocol revision is set and shipped as specified in the order.

To change the HART protocol revision after shipment, follow the procedure shown below.



IMPORTANT

When change the protocol revision, confirm the items below.

- Protocol revision supported by HART configuration tool must be the same or higher than new protocol revision of the device. (Read Section 8.1 "HART Protocol Revision")
- Confirm that the DD or DTM which is suitable to new protocol revision of device is installed in the configuration tool. (Read Section 8.1 "HART Protocol Revision" and Section 8.2 "HART Configuration Tool and Matching of Device Revision")

(1) Call up the parameter for protocol revision change

- Call up the parameter for protocol revision change Procedure to call up the **Chng universal rev** display.

[Root Menu] → Detailed setup → Device information → Revision numbers → Chng universal rev

(2) Active the parameter for protocol revision change

- Active the “Chng universal rev” method



IMPORTANT

The message is displayed to separate the device from the automatic control loop.
Confirm that the device is separated.

(3) Set the protocol revision number

Input the new revision number
An input column for new protocol revision number is displayed.
Input the new HART protocol revision number of “5” for HART 5 or “7” for HART 7.
Confirm the revision number in the ‘Next universal rev’.

[Root Menu] → Detailed setup → Device information → Revision numbers → Next universal rev

(4) Applying the new protocol revision

- Close the configuration tool
After completion of Chng universal rev method, close the HART configuration tool.



NOTE

When using a Fieldmate, close the main display of FieldMate.

- Restart the device
Turn off the power to the device, and turn it on.



IMPORTANT

New protocol revision is applied only after having performed restart of the device.



NOTE

A new HART revision number is displayed on the indicator after restart the device.

(5) Confirmation of the protocol revision number

- Confirming the new protocol revision
- Restart the HART configuration tool



NOTE

When execute the other parameter configuration or setting change, execute after restart the configuration tool.

- Confirm the new HART protocol revision number
Callup the **Universal rev** parameter, and confirm that the new HART revision number is displayed.
- Procedure to call up the **Universal rev** parameter.
[Root Menu] → Review → Review1 → Universal rev
5: HART protocol revision 5
7: HART protocol revision 7

8.10.4 Other Operations for the HART Configuration Tool

Regarding other operations for the HART Configuration Tool, read the HART Configuration Tool operations manual.

8.11 Menu Tree (HART 5)

Menu tree is different from DD and DTM. Read menu tree for configuration tool to be used.

• **DD (HART 5) Menu Tree**



F0805.ai

- (R) Read only
- (CR) Continuous read
- (RW) Read and Write
- (M) Method of HCF
- Unique Method of DY
- (MV) Only for Multi-Variable Type
- [] Parameter No. in display and BRAIN Terminal
- * Upload/Download
- ☆ Device revision 4.0 or later

A

| | | | |
|-------------------|-------|------|--|
| Process variables | | | |
| PV | [A20] | (CR) | |
| PV % rng | [A10] | (CR) | |
| AO1 | | (CR) | |
| Total | [A30] | (CR) | |
| (MV) Temp | [A41] | (CR) | |
| (MV) TV % rng | [A40] | (CR) | |
| (MV) AO3 | | (CR) | |

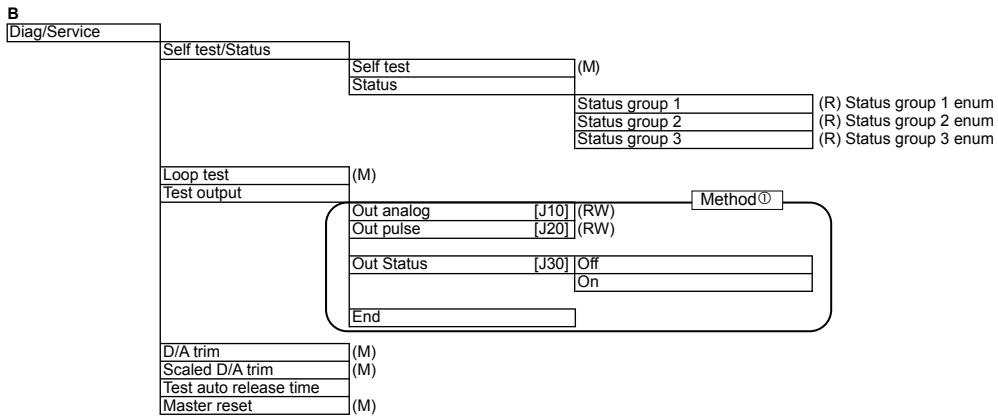

Status group 1 enum

| |
|-----------------------|
| Flow over output |
| Span set error |
| Pulse out over |
| Pulse set error |
| Device ID not entered |
| Sensor fault |
| Pre-amp fault |
| EEPROM fault |

Status group 2 enum

| |
|-----------------|
| Transient noise |
| High vibration |
| Clogging |
| Fluctuating |

Status group 3 enum

| |
|--------------------|
| Temp over output |
| Over temp |
| Temp sensor fault |
| Temp convert fault |

F0806.ai

(R) Read only
 (CR) Continuous read
 (RW) Read and Write
 (M) Method of HCF
 [] Unique Method of DY
 (MV) Only for Multi-Variable Type

[] Parameter No. in display and BRAIN Terminal
 * Upload/Download

C

Basic setup

| | | | |
|--|---------------------|--------------------|-------------------------|
| Tag * | [C10] | (RW) | Method② |
| Easy setup | Contact output * | [B20] | Off |
| | Scaled pulse | Pulse rate * | [B21] (RW) |
| | Unscaled pulse | ditto | |
| | Frequency * | Frequency at 100% | [B22] (RW) |
| | Alarm | | |
| | Flow SW (Low : On) | Setting level * | [B23] (RW) |
| | Flow SW (Low : Off) | ditto | |
| | Display mode | Upper display * | [B30] |
| | | Lower display * | [B31] |
| | Totalizer | Total | [A30] (CR) |
| | | Total start/stop * | [B40] |
| | | Total rate * | [B45] (RW) |
| | | Total reset | [B47] (M) |
| | Analog out select * | [B50] | Flow |
| | Temp | Temp unit | [D20] |
| | | Temp 0% | [B51] (RW) |
| | | Temp 100% | [B52] (RW) |
| | | Temp error out | [F58] |
| | | End | |
| Fluid * | [C20] | Liquid:Volume | Volumetric unit * [C22] |
| A message for thermometer type and "Saturated steam", "Superheat steam", "Gas: STD/Normal" or "Liquid: Mass" is selected Now *** setting mode of thermometer. Please set at another menu. Process abort. ***: A parameter selected in "Thermometer/ Function" | | | |
| | | Time unit * | [C40] |
| | | End | |
| | Gas/Steam:Volume | ditto | |
| | Liquid:Mass | Density unit * | [C25] |
| | | Process density * | [C26] (RW) |
| | | Mass unit * | [C27] |
| | | Time unit * | [C40] (RW) |
| | | End | |
| | Gas/Steam:Mas | ditto | |
| | Gas:STD/Normal | Temp unit * | [C30] (RW) |
| | | Process temp * | [C31] (RW) |
| | | Base temp * | [C32] (RW) |
| | | Pressure unit * | [C33] |
| | | Process pressure * | [C34] (RW) |
| | | Base pressure * | [C35] (RW) |
| | | Deviation * | [C36] (RW) |
| | | STD/Normal unit * | [C37] (RW) |
| | | Time unit * | [C40] (RW) |
| | | End | |
| Flow span * | | | (RW) |
| PV Damp | [B15] | | (RW) |

F0807.ai

- (R) Read only
- (CR) Continuous read
- (RW) Read and Write
- (M) Method of HCF
- Unique Method of DY
- (MV) Only for Multi-Variable Type
- [] Parameter No. in display and BRAIN Terminal
- * Upload/Download
- ☆ Device revision 4.0 or later

D

| | | | | | | | | | | | | | | | | | | | | | | | | | | | | | | | | | | | | | |
|--------------------|--|--------------------------------|-------|---------|------------------------|-------|---------------------------|----------------|--------------------|------------------|----------------|-----------------------|-----------------------|--|--------------------------|--------------------------|--------------------------|-----------|--------------------------------|--|------------------|-----|-----------------------------|-----------|-----------------------|--|-----------------------|--------------------|--|--|--------------------------|--|--------------------|-----|---------------------------------|--|-------------------------------------|
| Detailed setup | | | | | | | | | | | | | | | | | | | | | | | | | | | | | | | | | | | | | |
| Characterize meter | <table border="1" style="width: 100%; border-collapse: collapse;"> <tr><td>Nominal size *</td><td>[E10]</td><td>(RW)</td></tr> <tr><td>Body type *</td><td>[E20]</td><td>(RW)</td></tr> <tr><td>Sensor type *</td><td>[E30]</td><td>(RW)</td></tr> <tr><td>K-factor setup</td><td>K-factor unit * [E40]</td><td>(RW)</td></tr> <tr><td></td><td>K-factor * [E41]</td><td>(RW)</td></tr> <tr><td>Detector No. *</td><td></td><td>(RW)</td></tr> </table> | Nominal size * | [E10] | (RW) | Body type * | [E20] | (RW) | Sensor type * | [E30] | (RW) | K-factor setup | K-factor unit * [E40] | (RW) | | K-factor * [E41] | (RW) | Detector No. * | | (RW) | | | | | | | | | | | | | | | | | | |
| Nominal size * | [E10] | (RW) | | | | | | | | | | | | | | | | | | | | | | | | | | | | | | | | | | | |
| Body type * | [E20] | (RW) | | | | | | | | | | | | | | | | | | | | | | | | | | | | | | | | | | | |
| Sensor type * | [E30] | (RW) | | | | | | | | | | | | | | | | | | | | | | | | | | | | | | | | | | | |
| K-factor setup | K-factor unit * [E40] | (RW) | | | | | | | | | | | | | | | | | | | | | | | | | | | | | | | | | | | |
| | K-factor * [E41] | (RW) | | | | | | | | | | | | | | | | | | | | | | | | | | | | | | | | | | | |
| Detector No. * | | (RW) | | | | | | | | | | | | | | | | | | | | | | | | | | | | | | | | | | | |
| PV units | <table border="1" style="width: 100%; border-collapse: collapse;"> <tr><td>Fluid *</td><td>[C20]</td><td>Method④</td></tr> <tr><td></td><td></td><td style="text-align: right;">Method⑤</td></tr> <tr><td>Special unit *</td><td>[D40]</td><td>No</td></tr> <tr><td></td><td>Yes</td><td>Base unit * [D41] (R)</td></tr> <tr><td></td><td></td><td>User's unit * [D42] (RW)</td></tr> <tr><td></td><td></td><td>Conversion factor * [D43] (RW)</td></tr> <tr><td></td><td></td><td>End</td></tr> <tr><td></td><td>Special ☆</td><td>Base unit * (R)</td></tr> <tr><td></td><td></td><td>User's unit * (RW)</td></tr> <tr><td></td><td></td><td>Conversion factor * (RW)</td></tr> <tr><td></td><td></td><td>End</td></tr> </table> | Fluid * | [C20] | Method④ | | | Method⑤ | Special unit * | [D40] | No | | Yes | Base unit * [D41] (R) | | | User's unit * [D42] (RW) | | | Conversion factor * [D43] (RW) | | | End | | Special ☆ | Base unit * (R) | | | User's unit * (RW) | | | Conversion factor * (RW) | | | End | | | |
| Fluid * | [C20] | Method④ | | | | | | | | | | | | | | | | | | | | | | | | | | | | | | | | | | | |
| | | Method⑤ | | | | | | | | | | | | | | | | | | | | | | | | | | | | | | | | | | | |
| Special unit * | [D40] | No | | | | | | | | | | | | | | | | | | | | | | | | | | | | | | | | | | | |
| | Yes | Base unit * [D41] (R) | | | | | | | | | | | | | | | | | | | | | | | | | | | | | | | | | | | |
| | | User's unit * [D42] (RW) | | | | | | | | | | | | | | | | | | | | | | | | | | | | | | | | | | | |
| | | Conversion factor * [D43] (RW) | | | | | | | | | | | | | | | | | | | | | | | | | | | | | | | | | | | |
| | | End | | | | | | | | | | | | | | | | | | | | | | | | | | | | | | | | | | | |
| | Special ☆ | Base unit * (R) | | | | | | | | | | | | | | | | | | | | | | | | | | | | | | | | | | | |
| | | User's unit * (RW) | | | | | | | | | | | | | | | | | | | | | | | | | | | | | | | | | | | |
| | | Conversion factor * (RW) | | | | | | | | | | | | | | | | | | | | | | | | | | | | | | | | | | | |
| | | End | | | | | | | | | | | | | | | | | | | | | | | | | | | | | | | | | | | |
| Configure outputs | <table border="1" style="width: 100%; border-collapse: collapse;"> <tr><td colspan="2" style="background-color: #e0e0e0;">Analog outputs</td></tr> <tr><td></td><td>Flow span * [B10] (RW)</td></tr> <tr><td></td><td>Out limit(H) * [D30] (RW)</td></tr> <tr><td></td><td>Burn out [D35] (R)</td></tr> <tr><td>Contact output *</td><td>(M)</td></tr> <tr><td colspan="2" style="background-color: #e0e0e0;">Display mode</td></tr> <tr><td></td><td>Upper display [B30] (RW)</td></tr> <tr><td></td><td>Lower display [B31] (RW)</td></tr> <tr><td colspan="2" style="background-color: #e0e0e0;">Totalizer</td></tr> <tr><td></td><td>Total [A30] (CR)</td></tr> <tr><td></td><td>Total start/stop [B40] (RW)</td></tr> <tr><td></td><td>Total rate [B45] (RW)</td></tr> <tr><td></td><td>Total reset [B47] (M)</td></tr> <tr><td colspan="2" style="background-color: #e0e0e0;">HART output</td></tr> <tr><td></td><td>Poll addr (RW)</td></tr> <tr><td></td><td>Num req preams (R)</td></tr> <tr><td></td><td>Burst mode (RW) Burst mode enum</td></tr> <tr><td></td><td>Burst option (RW) Burst option enum</td></tr> </table> | Analog outputs | | | Flow span * [B10] (RW) | | Out limit(H) * [D30] (RW) | | Burn out [D35] (R) | Contact output * | (M) | Display mode | | | Upper display [B30] (RW) | | Lower display [B31] (RW) | Totalizer | | | Total [A30] (CR) | | Total start/stop [B40] (RW) | | Total rate [B45] (RW) | | Total reset [B47] (M) | HART output | | | Poll addr (RW) | | Num req preams (R) | | Burst mode (RW) Burst mode enum | | Burst option (RW) Burst option enum |
| Analog outputs | | | | | | | | | | | | | | | | | | | | | | | | | | | | | | | | | | | | | |
| | Flow span * [B10] (RW) | | | | | | | | | | | | | | | | | | | | | | | | | | | | | | | | | | | | |
| | Out limit(H) * [D30] (RW) | | | | | | | | | | | | | | | | | | | | | | | | | | | | | | | | | | | | |
| | Burn out [D35] (R) | | | | | | | | | | | | | | | | | | | | | | | | | | | | | | | | | | | | |
| Contact output * | (M) | | | | | | | | | | | | | | | | | | | | | | | | | | | | | | | | | | | | |
| Display mode | | | | | | | | | | | | | | | | | | | | | | | | | | | | | | | | | | | | | |
| | Upper display [B30] (RW) | | | | | | | | | | | | | | | | | | | | | | | | | | | | | | | | | | | | |
| | Lower display [B31] (RW) | | | | | | | | | | | | | | | | | | | | | | | | | | | | | | | | | | | | |
| Totalizer | | | | | | | | | | | | | | | | | | | | | | | | | | | | | | | | | | | | | |
| | Total [A30] (CR) | | | | | | | | | | | | | | | | | | | | | | | | | | | | | | | | | | | | |
| | Total start/stop [B40] (RW) | | | | | | | | | | | | | | | | | | | | | | | | | | | | | | | | | | | | |
| | Total rate [B45] (RW) | | | | | | | | | | | | | | | | | | | | | | | | | | | | | | | | | | | | |
| | Total reset [B47] (M) | | | | | | | | | | | | | | | | | | | | | | | | | | | | | | | | | | | | |
| HART output | | | | | | | | | | | | | | | | | | | | | | | | | | | | | | | | | | | | | |
| | Poll addr (RW) | | | | | | | | | | | | | | | | | | | | | | | | | | | | | | | | | | | | |
| | Num req preams (R) | | | | | | | | | | | | | | | | | | | | | | | | | | | | | | | | | | | | |
| | Burst mode (RW) Burst mode enum | | | | | | | | | | | | | | | | | | | | | | | | | | | | | | | | | | | | |
| | Burst option (RW) Burst option enum | | | | | | | | | | | | | | | | | | | | | | | | | | | | | | | | | | | | |

To be continued to next page (D1)

| | |
|-----------------|--|
| Burst mode enum | |
| Off | |
| On | |

| | |
|-------------------|--|
| Burst option enum | |
| PV | |
| %range/current | |
| Process vars/crnt | |

F0808.ai

(R) Read only
 (CR) Continuous read
 (RW) Read and Write
 (M) Method of HCF
 Unique Method of DY
 (MV) Only for Multi-Variable Type

[] Parameter No. in display and BRAIN Terminal
 * Upload/Download
 ☆ Device revision 4.0 or later

D1

| | |
|----------------------|--|
| Signal processing | |
| PV Damp | [B15] (RW) |
| Low cut * | [D10] (RW) |
| Temp setup | Temp unit [D20] (RW) Process temp [D21] (RW) |
| Density setup | Density unit [D25] (RW) Process density [D26] (RW) |
| Maintenance | TLA * [K10] (RW) Signal level * [K20] (RW) |
| Method⑥ | |
| Noise balance mode | [K25] Auto (RW) |
| | Manual Set noise ratio (RW) End |
| | Tuning at zero flow |
| Noise ratio * | [K26] (CR) |
| Maintenance data | Velocity [K30] (CR) Span velocity [K32] (CR) Vortex frequency [K34] (CR) Span frequency [K36] (CR) (MV) Density [K38] (CR) |
| Error record | [K40] Err record reset (M) Er record status 1 (CR) Er record status 1 enum Er record status 2 (CR) Status group 2 enum (MV) Er record status 3 (CR) Status group 3 enum |
| High vibration * | [K45] (RW) |
| Method⑦ | |
| Amplifier check | Set vortex frequency [K28] (RW) End |
| Menu type number | (RW) |
| Menu type | (R) |
| Adjust | User adjust * [H20] (RW) |
| Method⑧ | |
| Reynolds adjust * | [H25] Not active |
| | Active Process density (RW) Viscosity * (RW) End |
| Gas expansion fact * | [H30] Not active (RW) Active (RW) |
| Method⑨ | |
| Flow adjust * | [H40] Not active |
| | Active Set point 1-data * (RW) Set point 2-data * (RW) Set point 3-data * (RW) Set point 4-data * (RW) Set point 5-data * (RW) End |

To be continued to next page (D2)

Er record status 1 enum

| |
|------------------|
| Flow over output |
| Span set error |
| Pulse out over |
| Pulse set error |
| Sensor fault |
| Pre-amp fault |
| EEPROM fault |

F0809.ai

- (R) Read only
 - (CR) Continuous read
 - (RW) Read and Write
 - (M) Method of HCF
 - Unique Method of DY
 - (MV) Only for Multi-Variable Type
- [] Parameter No. in display and BRAIN Terminal
 - * Upload/Download
 - ☆ Device revision 4.0 or later

| | | | | | | | | | | | | | | | | | | | | | | | | | | | | | | | | | | | | | | | | | | | | | | | | | | | | | | | | | | | | | | | | | | | | | | | | | | | | | | | | | | | | | | | | | | | | | | | | | | | | | | | | | | | | | | | | | | | | | | | | | | | | | | | | | | | | | | | | | | | | | | | | | | | | | | | | | | | | | | | | | | | | | | | | | | | | | | | | | | | | | | | | | | | | | | | | | | | | | | | | | | | | | | | | | | | | | | | | | | | | | | | | | | | | | | | | | | | | | | | | | | | | | | | | | | | | | | | | | | | | | | | | | | | | | | | | | | | | | | | | | | | | | | | |
|--------------------|--|---------------------|-------------------------|---------|--------------------|--------------|---------|-----------|---------|--------------|------|---------------|-----|------------------|--|---------------|-----|-------------|-----|-----------------|-----------------|--------------|-----|------------------|-----|--------|-----|--------------------|-------|--------------------|-------|--|--|--|--|--|--|-----|--|--|--|--|--|--|--|--|-----------------|---------------------|------|--------------------|--|--|--|--|--|--|------------------------|------|--|--|--|--|--|--|--|-----------------|------|--|--|--|--|--|--|--|-----------------|------|--|--|--|--|--|--|-----|--|--|--|--|--|--|--|--|----------------|-----------------|------|--|--|--|--|--|--|--|-----------------|------|--|--|--|--|--|--|--|---------------------|------|--------------------|--|--|--|--|--|--|------------------------|------|--|--|--|--|--|--|--|---------------------|------|--|--|--|--|--|--|--|-----------------|------|--|--|--|--|--|--|--|-----------------------|------|--|--|--|--|--|--|--|-----------------|------|--|--|--|--|--|--|-----|--|--|--|--|--|--|--|--|-------------|--------------------|------|--|--|--|--|--|--|--|----------------------|------|--|--|--|--|--|--|--|-----------------|------|--|--|--|--|--|--|--|-----------------|------|--|--|--|--|--|--|--|-------------------------|------|--|--|--|--|--|--|--|-------------------------|------|--|--|--|--|--|--|--|-----------------|------|--|--|--|--|--|--|--|-----------------|------|--|--|--|--|--|--|-----|--|--|--|--|--|--|--|--|---------|--|--|--|--|--|--|--|--|----------------|-------|------|--|--|--|--|--|--|----------------|-------|------|--|--|--|--|--|--|---------------------|-------|---------|--|--|--|--|
| D2 | | | | | | | | | | | | | | | | | | | | | | | | | | | | | | | | | | | | | | | | | | | | | | | | | | | | | | | | | | | | | | | | | | | | | | | | | | | | | | | | | | | | | | | | | | | | | | | | | | | | | | | | | | | | | | | | | | | | | | | | | | | | | | | | | | | | | | | | | | | | | | | | | | | | | | | | | | | | | | | | | | | | | | | | | | | | | | | | | | | | | | | | | | | | | | | | | | | | | | | | | | | | | | | | | | | | | | | | | | | | | | | | | | | | | | | | | | | | | | | | | | | | | | | | | | | | | | | | | | | | | | | | | | | | | | | | | | | | | | | | | | | | | | | |
| Device information | <table border="1" style="width: 100%; border-collapse: collapse;"> <tr><td>Manufacturer</td><td>(R)</td></tr> <tr><td>Tag *</td><td>(RW)</td></tr> <tr><td>Descriptor *</td><td>(RW)</td></tr> <tr><td>Message *</td><td>(RW)</td></tr> <tr><td>Date *</td><td>(RW)</td></tr> <tr><td>Write protect</td><td>(R)</td></tr> <tr><td>Revision numbers</td><td></td></tr> <tr><td> Universal rev</td><td>(R)</td></tr> <tr><td> Fld dev rev</td><td>(R)</td></tr> <tr><td> Software rev</td><td>(R)</td></tr> <tr><td> Hardware rev</td><td>(R)</td></tr> <tr><td> Final asmbly num</td><td>(R)</td></tr> <tr><td> Dev id</td><td>(R)</td></tr> <tr><td> Next universal rev</td><td>(R) ☆</td></tr> <tr><td> Chng universal rev</td><td>(M) ☆</td></tr> </table> | Manufacturer | (R) | Tag * | (RW) | Descriptor * | (RW) | Message * | (RW) | Date * | (RW) | Write protect | (R) | Revision numbers | | Universal rev | (R) | Fld dev rev | (R) | Software rev | (R) | Hardware rev | (R) | Final asmbly num | (R) | Dev id | (R) | Next universal rev | (R) ☆ | Chng universal rev | (M) ☆ | | | | | | | | | | | | | | | | | | | | | | | | | | | | | | | | | | | | | | | | | | | | | | | | | | | | | | | | | | | | | | | | | | | | | | | | | | | | | | | | | | | | | | | | | | | | | | | | | | | | | | | | | | | | | | | | | | | | | | | | | | | | | | | | | | | | | | | | | | | | | | | | | | | | | | | | | | | | | | | | | | | | | | | | | | | | | | | | | | | | | | | | | | | | | | | | | | | | | | | | | | | | | | | | | | | | | | | | | | | | | | | | | | | | | | | | | | | | | | | | | | | | | | | | | | | | | | | | |
| Manufacturer | (R) | | | | | | | | | | | | | | | | | | | | | | | | | | | | | | | | | | | | | | | | | | | | | | | | | | | | | | | | | | | | | | | | | | | | | | | | | | | | | | | | | | | | | | | | | | | | | | | | | | | | | | | | | | | | | | | | | | | | | | | | | | | | | | | | | | | | | | | | | | | | | | | | | | | | | | | | | | | | | | | | | | | | | | | | | | | | | | | | | | | | | | | | | | | | | | | | | | | | | | | | | | | | | | | | | | | | | | | | | | | | | | | | | | | | | | | | | | | | | | | | | | | | | | | | | | | | | | | | | | | | | | | | | | | | | | | | | | | | | | | | | | | | | | |
| Tag * | (RW) | | | | | | | | | | | | | | | | | | | | | | | | | | | | | | | | | | | | | | | | | | | | | | | | | | | | | | | | | | | | | | | | | | | | | | | | | | | | | | | | | | | | | | | | | | | | | | | | | | | | | | | | | | | | | | | | | | | | | | | | | | | | | | | | | | | | | | | | | | | | | | | | | | | | | | | | | | | | | | | | | | | | | | | | | | | | | | | | | | | | | | | | | | | | | | | | | | | | | | | | | | | | | | | | | | | | | | | | | | | | | | | | | | | | | | | | | | | | | | | | | | | | | | | | | | | | | | | | | | | | | | | | | | | | | | | | | | | | | | | | | | | | | | |
| Descriptor * | (RW) | | | | | | | | | | | | | | | | | | | | | | | | | | | | | | | | | | | | | | | | | | | | | | | | | | | | | | | | | | | | | | | | | | | | | | | | | | | | | | | | | | | | | | | | | | | | | | | | | | | | | | | | | | | | | | | | | | | | | | | | | | | | | | | | | | | | | | | | | | | | | | | | | | | | | | | | | | | | | | | | | | | | | | | | | | | | | | | | | | | | | | | | | | | | | | | | | | | | | | | | | | | | | | | | | | | | | | | | | | | | | | | | | | | | | | | | | | | | | | | | | | | | | | | | | | | | | | | | | | | | | | | | | | | | | | | | | | | | | | | | | | | | | | |
| Message * | (RW) | | | | | | | | | | | | | | | | | | | | | | | | | | | | | | | | | | | | | | | | | | | | | | | | | | | | | | | | | | | | | | | | | | | | | | | | | | | | | | | | | | | | | | | | | | | | | | | | | | | | | | | | | | | | | | | | | | | | | | | | | | | | | | | | | | | | | | | | | | | | | | | | | | | | | | | | | | | | | | | | | | | | | | | | | | | | | | | | | | | | | | | | | | | | | | | | | | | | | | | | | | | | | | | | | | | | | | | | | | | | | | | | | | | | | | | | | | | | | | | | | | | | | | | | | | | | | | | | | | | | | | | | | | | | | | | | | | | | | | | | | | | | | | |
| Date * | (RW) | | | | | | | | | | | | | | | | | | | | | | | | | | | | | | | | | | | | | | | | | | | | | | | | | | | | | | | | | | | | | | | | | | | | | | | | | | | | | | | | | | | | | | | | | | | | | | | | | | | | | | | | | | | | | | | | | | | | | | | | | | | | | | | | | | | | | | | | | | | | | | | | | | | | | | | | | | | | | | | | | | | | | | | | | | | | | | | | | | | | | | | | | | | | | | | | | | | | | | | | | | | | | | | | | | | | | | | | | | | | | | | | | | | | | | | | | | | | | | | | | | | | | | | | | | | | | | | | | | | | | | | | | | | | | | | | | | | | | | | | | | | | | | |
| Write protect | (R) | | | | | | | | | | | | | | | | | | | | | | | | | | | | | | | | | | | | | | | | | | | | | | | | | | | | | | | | | | | | | | | | | | | | | | | | | | | | | | | | | | | | | | | | | | | | | | | | | | | | | | | | | | | | | | | | | | | | | | | | | | | | | | | | | | | | | | | | | | | | | | | | | | | | | | | | | | | | | | | | | | | | | | | | | | | | | | | | | | | | | | | | | | | | | | | | | | | | | | | | | | | | | | | | | | | | | | | | | | | | | | | | | | | | | | | | | | | | | | | | | | | | | | | | | | | | | | | | | | | | | | | | | | | | | | | | | | | | | | | | | | | | | | |
| Revision numbers | | | | | | | | | | | | | | | | | | | | | | | | | | | | | | | | | | | | | | | | | | | | | | | | | | | | | | | | | | | | | | | | | | | | | | | | | | | | | | | | | | | | | | | | | | | | | | | | | | | | | | | | | | | | | | | | | | | | | | | | | | | | | | | | | | | | | | | | | | | | | | | | | | | | | | | | | | | | | | | | | | | | | | | | | | | | | | | | | | | | | | | | | | | | | | | | | | | | | | | | | | | | | | | | | | | | | | | | | | | | | | | | | | | | | | | | | | | | | | | | | | | | | | | | | | | | | | | | | | | | | | | | | | | | | | | | | | | | | | | | | | | | | | | |
| Universal rev | (R) | | | | | | | | | | | | | | | | | | | | | | | | | | | | | | | | | | | | | | | | | | | | | | | | | | | | | | | | | | | | | | | | | | | | | | | | | | | | | | | | | | | | | | | | | | | | | | | | | | | | | | | | | | | | | | | | | | | | | | | | | | | | | | | | | | | | | | | | | | | | | | | | | | | | | | | | | | | | | | | | | | | | | | | | | | | | | | | | | | | | | | | | | | | | | | | | | | | | | | | | | | | | | | | | | | | | | | | | | | | | | | | | | | | | | | | | | | | | | | | | | | | | | | | | | | | | | | | | | | | | | | | | | | | | | | | | | | | | | | | | | | | | | | |
| Fld dev rev | (R) | | | | | | | | | | | | | | | | | | | | | | | | | | | | | | | | | | | | | | | | | | | | | | | | | | | | | | | | | | | | | | | | | | | | | | | | | | | | | | | | | | | | | | | | | | | | | | | | | | | | | | | | | | | | | | | | | | | | | | | | | | | | | | | | | | | | | | | | | | | | | | | | | | | | | | | | | | | | | | | | | | | | | | | | | | | | | | | | | | | | | | | | | | | | | | | | | | | | | | | | | | | | | | | | | | | | | | | | | | | | | | | | | | | | | | | | | | | | | | | | | | | | | | | | | | | | | | | | | | | | | | | | | | | | | | | | | | | | | | | | | | | | | | |
| Software rev | (R) | | | | | | | | | | | | | | | | | | | | | | | | | | | | | | | | | | | | | | | | | | | | | | | | | | | | | | | | | | | | | | | | | | | | | | | | | | | | | | | | | | | | | | | | | | | | | | | | | | | | | | | | | | | | | | | | | | | | | | | | | | | | | | | | | | | | | | | | | | | | | | | | | | | | | | | | | | | | | | | | | | | | | | | | | | | | | | | | | | | | | | | | | | | | | | | | | | | | | | | | | | | | | | | | | | | | | | | | | | | | | | | | | | | | | | | | | | | | | | | | | | | | | | | | | | | | | | | | | | | | | | | | | | | | | | | | | | | | | | | | | | | | | | |
| Hardware rev | (R) | | | | | | | | | | | | | | | | | | | | | | | | | | | | | | | | | | | | | | | | | | | | | | | | | | | | | | | | | | | | | | | | | | | | | | | | | | | | | | | | | | | | | | | | | | | | | | | | | | | | | | | | | | | | | | | | | | | | | | | | | | | | | | | | | | | | | | | | | | | | | | | | | | | | | | | | | | | | | | | | | | | | | | | | | | | | | | | | | | | | | | | | | | | | | | | | | | | | | | | | | | | | | | | | | | | | | | | | | | | | | | | | | | | | | | | | | | | | | | | | | | | | | | | | | | | | | | | | | | | | | | | | | | | | | | | | | | | | | | | | | | | | | | |
| Final asmbly num | (R) | | | | | | | | | | | | | | | | | | | | | | | | | | | | | | | | | | | | | | | | | | | | | | | | | | | | | | | | | | | | | | | | | | | | | | | | | | | | | | | | | | | | | | | | | | | | | | | | | | | | | | | | | | | | | | | | | | | | | | | | | | | | | | | | | | | | | | | | | | | | | | | | | | | | | | | | | | | | | | | | | | | | | | | | | | | | | | | | | | | | | | | | | | | | | | | | | | | | | | | | | | | | | | | | | | | | | | | | | | | | | | | | | | | | | | | | | | | | | | | | | | | | | | | | | | | | | | | | | | | | | | | | | | | | | | | | | | | | | | | | | | | | | | |
| Dev id | (R) | | | | | | | | | | | | | | | | | | | | | | | | | | | | | | | | | | | | | | | | | | | | | | | | | | | | | | | | | | | | | | | | | | | | | | | | | | | | | | | | | | | | | | | | | | | | | | | | | | | | | | | | | | | | | | | | | | | | | | | | | | | | | | | | | | | | | | | | | | | | | | | | | | | | | | | | | | | | | | | | | | | | | | | | | | | | | | | | | | | | | | | | | | | | | | | | | | | | | | | | | | | | | | | | | | | | | | | | | | | | | | | | | | | | | | | | | | | | | | | | | | | | | | | | | | | | | | | | | | | | | | | | | | | | | | | | | | | | | | | | | | | | | | |
| Next universal rev | (R) ☆ | | | | | | | | | | | | | | | | | | | | | | | | | | | | | | | | | | | | | | | | | | | | | | | | | | | | | | | | | | | | | | | | | | | | | | | | | | | | | | | | | | | | | | | | | | | | | | | | | | | | | | | | | | | | | | | | | | | | | | | | | | | | | | | | | | | | | | | | | | | | | | | | | | | | | | | | | | | | | | | | | | | | | | | | | | | | | | | | | | | | | | | | | | | | | | | | | | | | | | | | | | | | | | | | | | | | | | | | | | | | | | | | | | | | | | | | | | | | | | | | | | | | | | | | | | | | | | | | | | | | | | | | | | | | | | | | | | | | | | | | | | | | | | |
| Chng universal rev | (M) ☆ | | | | | | | | | | | | | | | | | | | | | | | | | | | | | | | | | | | | | | | | | | | | | | | | | | | | | | | | | | | | | | | | | | | | | | | | | | | | | | | | | | | | | | | | | | | | | | | | | | | | | | | | | | | | | | | | | | | | | | | | | | | | | | | | | | | | | | | | | | | | | | | | | | | | | | | | | | | | | | | | | | | | | | | | | | | | | | | | | | | | | | | | | | | | | | | | | | | | | | | | | | | | | | | | | | | | | | | | | | | | | | | | | | | | | | | | | | | | | | | | | | | | | | | | | | | | | | | | | | | | | | | | | | | | | | | | | | | | | | | | | | | | | | |
| (MV) Thermometer | <table border="1" style="width: 100%; border-collapse: collapse;"> <tr> <td style="width: 15%;">Function *</td> <td style="width: 10%;">[F10]</td> <td style="width: 15%;"></td> <td style="width: 15%;"></td> <td style="width: 15%;"></td> <td style="width: 15%;"></td> <td style="width: 15%;"></td> <td style="width: 15%;">Method®</td> </tr> <tr> <td colspan="8" style="text-align: center;">Monitor only</td> </tr> <tr> <td colspan="2"></td> <td>Saturated steam</td> <td>Mass unit [F12]</td> <td>(RW)</td> <td colspan="3"></td> <td></td> </tr> <tr> <td colspan="2"></td> <td></td> <td>Time unit [F35]</td> <td>(RW)</td> <td colspan="3"></td> <td></td> </tr> <tr> <td colspan="2"></td> <td colspan="6" style="text-align: center;">End</td> <td></td> </tr> <tr> <td colspan="2"></td> <td>Superheat steam</td> <td>Pressure unit [F14]</td> <td>(RW)</td> <td colspan="3">Pressure unit enum</td> <td></td> </tr> <tr> <td colspan="2"></td> <td></td> <td>Process pressure [F15]</td> <td>(RW)</td> <td colspan="3"></td> <td></td> </tr> <tr> <td colspan="2"></td> <td></td> <td>Mass unit [F16]</td> <td>(RW)</td> <td colspan="3"></td> <td></td> </tr> <tr> <td colspan="2"></td> <td></td> <td>Time unit [F35]</td> <td>(RW)</td> <td colspan="3"></td> <td></td> </tr> <tr> <td colspan="2"></td> <td colspan="6" style="text-align: center;">End</td> <td></td> </tr> <tr> <td colspan="2"></td> <td>Gas:STD/Normal</td> <td>Temp unit [F18]</td> <td>(RW)</td> <td colspan="3"></td> <td></td> </tr> <tr> <td colspan="2"></td> <td></td> <td>Base temp [F19]</td> <td>(RW)</td> <td colspan="3"></td> <td></td> </tr> <tr> <td colspan="2"></td> <td></td> <td>Pressure unit [F20]</td> <td>(RW)</td> <td colspan="3">Pressure unit enum</td> <td></td> </tr> <tr> <td colspan="2"></td> <td></td> <td>Process pressure [F21]</td> <td>(RW)</td> <td colspan="3"></td> <td></td> </tr> <tr> <td colspan="2"></td> <td></td> <td>Base pressure [F22]</td> <td>(RW)</td> <td colspan="3"></td> <td></td> </tr> <tr> <td colspan="2"></td> <td></td> <td>Deviation [F23]</td> <td>(RW)</td> <td colspan="3"></td> <td></td> </tr> <tr> <td colspan="2"></td> <td></td> <td>STD/Normal unit [F24]</td> <td>(RW)</td> <td colspan="3"></td> <td></td> </tr> <tr> <td colspan="2"></td> <td></td> <td>Time unit [F35]</td> <td>(RW)</td> <td colspan="3"></td> <td></td> </tr> <tr> <td colspan="2"></td> <td colspan="6" style="text-align: center;">End</td> <td></td> </tr> <tr> <td colspan="2"></td> <td>Liquid:Mass</td> <td>Density unit [F26]</td> <td>(RW)</td> <td colspan="3"></td> <td></td> </tr> <tr> <td colspan="2"></td> <td></td> <td>Base density * [F27]</td> <td>(RW)</td> <td colspan="3"></td> <td></td> </tr> <tr> <td colspan="2"></td> <td></td> <td>Temp unit [F28]</td> <td>(RW)</td> <td colspan="3"></td> <td></td> </tr> <tr> <td colspan="2"></td> <td></td> <td>Base temp [F29]</td> <td>(RW)</td> <td colspan="3"></td> <td></td> </tr> <tr> <td colspan="2"></td> <td></td> <td>1'st temp coeff * [F30]</td> <td>(RW)</td> <td colspan="3"></td> <td></td> </tr> <tr> <td colspan="2"></td> <td></td> <td>2'nd temp coeff * [F31]</td> <td>(RW)</td> <td colspan="3"></td> <td></td> </tr> <tr> <td colspan="2"></td> <td></td> <td>Mass unit [F32]</td> <td>(RW)</td> <td colspan="3"></td> <td></td> </tr> <tr> <td colspan="2"></td> <td></td> <td>Time unit [F35]</td> <td>(RW)</td> <td colspan="3"></td> <td></td> </tr> <tr> <td colspan="2"></td> <td colspan="6" style="text-align: center;">End</td> <td></td> </tr> <tr> <td colspan="2"></td> <td colspan="6" style="text-align: center;">Not use</td> <td></td> </tr> <tr> <td colspan="2"></td> <td>Cable length *</td> <td>[F52]</td> <td>(RW)</td> <td colspan="3"></td> <td></td> </tr> <tr> <td colspan="2"></td> <td>Temp damping *</td> <td>[F50]</td> <td>(RW)</td> <td colspan="3"></td> <td></td> </tr> <tr> <td colspan="2"></td> <td>Analog out select *</td> <td>[F55]</td> <td>Method®</td> <td colspan="3"></td> <td></td> </tr> </table> | Function * | [F10] | | | | | | Method® | Monitor only | | | | | | | | | | Saturated steam | Mass unit [F12] | (RW) | | | | | | | | Time unit [F35] | (RW) | | | | | | | End | | | | | | | | | Superheat steam | Pressure unit [F14] | (RW) | Pressure unit enum | | | | | | | Process pressure [F15] | (RW) | | | | | | | | Mass unit [F16] | (RW) | | | | | | | | Time unit [F35] | (RW) | | | | | | | End | | | | | | | | | Gas:STD/Normal | Temp unit [F18] | (RW) | | | | | | | | Base temp [F19] | (RW) | | | | | | | | Pressure unit [F20] | (RW) | Pressure unit enum | | | | | | | Process pressure [F21] | (RW) | | | | | | | | Base pressure [F22] | (RW) | | | | | | | | Deviation [F23] | (RW) | | | | | | | | STD/Normal unit [F24] | (RW) | | | | | | | | Time unit [F35] | (RW) | | | | | | | End | | | | | | | | | Liquid:Mass | Density unit [F26] | (RW) | | | | | | | | Base density * [F27] | (RW) | | | | | | | | Temp unit [F28] | (RW) | | | | | | | | Base temp [F29] | (RW) | | | | | | | | 1'st temp coeff * [F30] | (RW) | | | | | | | | 2'nd temp coeff * [F31] | (RW) | | | | | | | | Mass unit [F32] | (RW) | | | | | | | | Time unit [F35] | (RW) | | | | | | | End | | | | | | | | | Not use | | | | | | | | | Cable length * | [F52] | (RW) | | | | | | | Temp damping * | [F50] | (RW) | | | | | | | Analog out select * | [F55] | Method® | | | | |
| Function * | [F10] | | | | | | Method® | | | | | | | | | | | | | | | | | | | | | | | | | | | | | | | | | | | | | | | | | | | | | | | | | | | | | | | | | | | | | | | | | | | | | | | | | | | | | | | | | | | | | | | | | | | | | | | | | | | | | | | | | | | | | | | | | | | | | | | | | | | | | | | | | | | | | | | | | | | | | | | | | | | | | | | | | | | | | | | | | | | | | | | | | | | | | | | | | | | | | | | | | | | | | | | | | | | | | | | | | | | | | | | | | | | | | | | | | | | | | | | | | | | | | | | | | | | | | | | | | | | | | | | | | | | | | | | | | | | | | | | | | | | | | | | | | | | | | | | | |
| Monitor only | | | | | | | | | | | | | | | | | | | | | | | | | | | | | | | | | | | | | | | | | | | | | | | | | | | | | | | | | | | | | | | | | | | | | | | | | | | | | | | | | | | | | | | | | | | | | | | | | | | | | | | | | | | | | | | | | | | | | | | | | | | | | | | | | | | | | | | | | | | | | | | | | | | | | | | | | | | | | | | | | | | | | | | | | | | | | | | | | | | | | | | | | | | | | | | | | | | | | | | | | | | | | | | | | | | | | | | | | | | | | | | | | | | | | | | | | | | | | | | | | | | | | | | | | | | | | | | | | | | | | | | | | | | | | | | | | | | | | | | | | | | | | | | |
| | | Saturated steam | Mass unit [F12] | (RW) | | | | | | | | | | | | | | | | | | | | | | | | | | | | | | | | | | | | | | | | | | | | | | | | | | | | | | | | | | | | | | | | | | | | | | | | | | | | | | | | | | | | | | | | | | | | | | | | | | | | | | | | | | | | | | | | | | | | | | | | | | | | | | | | | | | | | | | | | | | | | | | | | | | | | | | | | | | | | | | | | | | | | | | | | | | | | | | | | | | | | | | | | | | | | | | | | | | | | | | | | | | | | | | | | | | | | | | | | | | | | | | | | | | | | | | | | | | | | | | | | | | | | | | | | | | | | | | | | | | | | | | | | | | | | | | | | | | | | | | | | | | |
| | | | Time unit [F35] | (RW) | | | | | | | | | | | | | | | | | | | | | | | | | | | | | | | | | | | | | | | | | | | | | | | | | | | | | | | | | | | | | | | | | | | | | | | | | | | | | | | | | | | | | | | | | | | | | | | | | | | | | | | | | | | | | | | | | | | | | | | | | | | | | | | | | | | | | | | | | | | | | | | | | | | | | | | | | | | | | | | | | | | | | | | | | | | | | | | | | | | | | | | | | | | | | | | | | | | | | | | | | | | | | | | | | | | | | | | | | | | | | | | | | | | | | | | | | | | | | | | | | | | | | | | | | | | | | | | | | | | | | | | | | | | | | | | | | | | | | | | | | | | |
| | | End | | | | | | | | | | | | | | | | | | | | | | | | | | | | | | | | | | | | | | | | | | | | | | | | | | | | | | | | | | | | | | | | | | | | | | | | | | | | | | | | | | | | | | | | | | | | | | | | | | | | | | | | | | | | | | | | | | | | | | | | | | | | | | | | | | | | | | | | | | | | | | | | | | | | | | | | | | | | | | | | | | | | | | | | | | | | | | | | | | | | | | | | | | | | | | | | | | | | | | | | | | | | | | | | | | | | | | | | | | | | | | | | | | | | | | | | | | | | | | | | | | | | | | | | | | | | | | | | | | | | | | | | | | | | | | | | | | | | | | | | | | | | | |
| | | Superheat steam | Pressure unit [F14] | (RW) | Pressure unit enum | | | | | | | | | | | | | | | | | | | | | | | | | | | | | | | | | | | | | | | | | | | | | | | | | | | | | | | | | | | | | | | | | | | | | | | | | | | | | | | | | | | | | | | | | | | | | | | | | | | | | | | | | | | | | | | | | | | | | | | | | | | | | | | | | | | | | | | | | | | | | | | | | | | | | | | | | | | | | | | | | | | | | | | | | | | | | | | | | | | | | | | | | | | | | | | | | | | | | | | | | | | | | | | | | | | | | | | | | | | | | | | | | | | | | | | | | | | | | | | | | | | | | | | | | | | | | | | | | | | | | | | | | | | | | | | | | | | | | | | | | | |
| | | | Process pressure [F15] | (RW) | | | | | | | | | | | | | | | | | | | | | | | | | | | | | | | | | | | | | | | | | | | | | | | | | | | | | | | | | | | | | | | | | | | | | | | | | | | | | | | | | | | | | | | | | | | | | | | | | | | | | | | | | | | | | | | | | | | | | | | | | | | | | | | | | | | | | | | | | | | | | | | | | | | | | | | | | | | | | | | | | | | | | | | | | | | | | | | | | | | | | | | | | | | | | | | | | | | | | | | | | | | | | | | | | | | | | | | | | | | | | | | | | | | | | | | | | | | | | | | | | | | | | | | | | | | | | | | | | | | | | | | | | | | | | | | | | | | | | | | | | | | |
| | | | Mass unit [F16] | (RW) | | | | | | | | | | | | | | | | | | | | | | | | | | | | | | | | | | | | | | | | | | | | | | | | | | | | | | | | | | | | | | | | | | | | | | | | | | | | | | | | | | | | | | | | | | | | | | | | | | | | | | | | | | | | | | | | | | | | | | | | | | | | | | | | | | | | | | | | | | | | | | | | | | | | | | | | | | | | | | | | | | | | | | | | | | | | | | | | | | | | | | | | | | | | | | | | | | | | | | | | | | | | | | | | | | | | | | | | | | | | | | | | | | | | | | | | | | | | | | | | | | | | | | | | | | | | | | | | | | | | | | | | | | | | | | | | | | | | | | | | | | | |
| | | | Time unit [F35] | (RW) | | | | | | | | | | | | | | | | | | | | | | | | | | | | | | | | | | | | | | | | | | | | | | | | | | | | | | | | | | | | | | | | | | | | | | | | | | | | | | | | | | | | | | | | | | | | | | | | | | | | | | | | | | | | | | | | | | | | | | | | | | | | | | | | | | | | | | | | | | | | | | | | | | | | | | | | | | | | | | | | | | | | | | | | | | | | | | | | | | | | | | | | | | | | | | | | | | | | | | | | | | | | | | | | | | | | | | | | | | | | | | | | | | | | | | | | | | | | | | | | | | | | | | | | | | | | | | | | | | | | | | | | | | | | | | | | | | | | | | | | | | | |
| | | End | | | | | | | | | | | | | | | | | | | | | | | | | | | | | | | | | | | | | | | | | | | | | | | | | | | | | | | | | | | | | | | | | | | | | | | | | | | | | | | | | | | | | | | | | | | | | | | | | | | | | | | | | | | | | | | | | | | | | | | | | | | | | | | | | | | | | | | | | | | | | | | | | | | | | | | | | | | | | | | | | | | | | | | | | | | | | | | | | | | | | | | | | | | | | | | | | | | | | | | | | | | | | | | | | | | | | | | | | | | | | | | | | | | | | | | | | | | | | | | | | | | | | | | | | | | | | | | | | | | | | | | | | | | | | | | | | | | | | | | | | | | | | |
| | | Gas:STD/Normal | Temp unit [F18] | (RW) | | | | | | | | | | | | | | | | | | | | | | | | | | | | | | | | | | | | | | | | | | | | | | | | | | | | | | | | | | | | | | | | | | | | | | | | | | | | | | | | | | | | | | | | | | | | | | | | | | | | | | | | | | | | | | | | | | | | | | | | | | | | | | | | | | | | | | | | | | | | | | | | | | | | | | | | | | | | | | | | | | | | | | | | | | | | | | | | | | | | | | | | | | | | | | | | | | | | | | | | | | | | | | | | | | | | | | | | | | | | | | | | | | | | | | | | | | | | | | | | | | | | | | | | | | | | | | | | | | | | | | | | | | | | | | | | | | | | | | | | | | | |
| | | | Base temp [F19] | (RW) | | | | | | | | | | | | | | | | | | | | | | | | | | | | | | | | | | | | | | | | | | | | | | | | | | | | | | | | | | | | | | | | | | | | | | | | | | | | | | | | | | | | | | | | | | | | | | | | | | | | | | | | | | | | | | | | | | | | | | | | | | | | | | | | | | | | | | | | | | | | | | | | | | | | | | | | | | | | | | | | | | | | | | | | | | | | | | | | | | | | | | | | | | | | | | | | | | | | | | | | | | | | | | | | | | | | | | | | | | | | | | | | | | | | | | | | | | | | | | | | | | | | | | | | | | | | | | | | | | | | | | | | | | | | | | | | | | | | | | | | | | | |
| | | | Pressure unit [F20] | (RW) | Pressure unit enum | | | | | | | | | | | | | | | | | | | | | | | | | | | | | | | | | | | | | | | | | | | | | | | | | | | | | | | | | | | | | | | | | | | | | | | | | | | | | | | | | | | | | | | | | | | | | | | | | | | | | | | | | | | | | | | | | | | | | | | | | | | | | | | | | | | | | | | | | | | | | | | | | | | | | | | | | | | | | | | | | | | | | | | | | | | | | | | | | | | | | | | | | | | | | | | | | | | | | | | | | | | | | | | | | | | | | | | | | | | | | | | | | | | | | | | | | | | | | | | | | | | | | | | | | | | | | | | | | | | | | | | | | | | | | | | | | | | | | | | | | | |
| | | | Process pressure [F21] | (RW) | | | | | | | | | | | | | | | | | | | | | | | | | | | | | | | | | | | | | | | | | | | | | | | | | | | | | | | | | | | | | | | | | | | | | | | | | | | | | | | | | | | | | | | | | | | | | | | | | | | | | | | | | | | | | | | | | | | | | | | | | | | | | | | | | | | | | | | | | | | | | | | | | | | | | | | | | | | | | | | | | | | | | | | | | | | | | | | | | | | | | | | | | | | | | | | | | | | | | | | | | | | | | | | | | | | | | | | | | | | | | | | | | | | | | | | | | | | | | | | | | | | | | | | | | | | | | | | | | | | | | | | | | | | | | | | | | | | | | | | | | | | |
| | | | Base pressure [F22] | (RW) | | | | | | | | | | | | | | | | | | | | | | | | | | | | | | | | | | | | | | | | | | | | | | | | | | | | | | | | | | | | | | | | | | | | | | | | | | | | | | | | | | | | | | | | | | | | | | | | | | | | | | | | | | | | | | | | | | | | | | | | | | | | | | | | | | | | | | | | | | | | | | | | | | | | | | | | | | | | | | | | | | | | | | | | | | | | | | | | | | | | | | | | | | | | | | | | | | | | | | | | | | | | | | | | | | | | | | | | | | | | | | | | | | | | | | | | | | | | | | | | | | | | | | | | | | | | | | | | | | | | | | | | | | | | | | | | | | | | | | | | | | | |
| | | | Deviation [F23] | (RW) | | | | | | | | | | | | | | | | | | | | | | | | | | | | | | | | | | | | | | | | | | | | | | | | | | | | | | | | | | | | | | | | | | | | | | | | | | | | | | | | | | | | | | | | | | | | | | | | | | | | | | | | | | | | | | | | | | | | | | | | | | | | | | | | | | | | | | | | | | | | | | | | | | | | | | | | | | | | | | | | | | | | | | | | | | | | | | | | | | | | | | | | | | | | | | | | | | | | | | | | | | | | | | | | | | | | | | | | | | | | | | | | | | | | | | | | | | | | | | | | | | | | | | | | | | | | | | | | | | | | | | | | | | | | | | | | | | | | | | | | | | | |
| | | | STD/Normal unit [F24] | (RW) | | | | | | | | | | | | | | | | | | | | | | | | | | | | | | | | | | | | | | | | | | | | | | | | | | | | | | | | | | | | | | | | | | | | | | | | | | | | | | | | | | | | | | | | | | | | | | | | | | | | | | | | | | | | | | | | | | | | | | | | | | | | | | | | | | | | | | | | | | | | | | | | | | | | | | | | | | | | | | | | | | | | | | | | | | | | | | | | | | | | | | | | | | | | | | | | | | | | | | | | | | | | | | | | | | | | | | | | | | | | | | | | | | | | | | | | | | | | | | | | | | | | | | | | | | | | | | | | | | | | | | | | | | | | | | | | | | | | | | | | | | | |
| | | | Time unit [F35] | (RW) | | | | | | | | | | | | | | | | | | | | | | | | | | | | | | | | | | | | | | | | | | | | | | | | | | | | | | | | | | | | | | | | | | | | | | | | | | | | | | | | | | | | | | | | | | | | | | | | | | | | | | | | | | | | | | | | | | | | | | | | | | | | | | | | | | | | | | | | | | | | | | | | | | | | | | | | | | | | | | | | | | | | | | | | | | | | | | | | | | | | | | | | | | | | | | | | | | | | | | | | | | | | | | | | | | | | | | | | | | | | | | | | | | | | | | | | | | | | | | | | | | | | | | | | | | | | | | | | | | | | | | | | | | | | | | | | | | | | | | | | | | | |
| | | End | | | | | | | | | | | | | | | | | | | | | | | | | | | | | | | | | | | | | | | | | | | | | | | | | | | | | | | | | | | | | | | | | | | | | | | | | | | | | | | | | | | | | | | | | | | | | | | | | | | | | | | | | | | | | | | | | | | | | | | | | | | | | | | | | | | | | | | | | | | | | | | | | | | | | | | | | | | | | | | | | | | | | | | | | | | | | | | | | | | | | | | | | | | | | | | | | | | | | | | | | | | | | | | | | | | | | | | | | | | | | | | | | | | | | | | | | | | | | | | | | | | | | | | | | | | | | | | | | | | | | | | | | | | | | | | | | | | | | | | | | | | | | |
| | | Liquid:Mass | Density unit [F26] | (RW) | | | | | | | | | | | | | | | | | | | | | | | | | | | | | | | | | | | | | | | | | | | | | | | | | | | | | | | | | | | | | | | | | | | | | | | | | | | | | | | | | | | | | | | | | | | | | | | | | | | | | | | | | | | | | | | | | | | | | | | | | | | | | | | | | | | | | | | | | | | | | | | | | | | | | | | | | | | | | | | | | | | | | | | | | | | | | | | | | | | | | | | | | | | | | | | | | | | | | | | | | | | | | | | | | | | | | | | | | | | | | | | | | | | | | | | | | | | | | | | | | | | | | | | | | | | | | | | | | | | | | | | | | | | | | | | | | | | | | | | | | | | |
| | | | Base density * [F27] | (RW) | | | | | | | | | | | | | | | | | | | | | | | | | | | | | | | | | | | | | | | | | | | | | | | | | | | | | | | | | | | | | | | | | | | | | | | | | | | | | | | | | | | | | | | | | | | | | | | | | | | | | | | | | | | | | | | | | | | | | | | | | | | | | | | | | | | | | | | | | | | | | | | | | | | | | | | | | | | | | | | | | | | | | | | | | | | | | | | | | | | | | | | | | | | | | | | | | | | | | | | | | | | | | | | | | | | | | | | | | | | | | | | | | | | | | | | | | | | | | | | | | | | | | | | | | | | | | | | | | | | | | | | | | | | | | | | | | | | | | | | | | | | |
| | | | Temp unit [F28] | (RW) | | | | | | | | | | | | | | | | | | | | | | | | | | | | | | | | | | | | | | | | | | | | | | | | | | | | | | | | | | | | | | | | | | | | | | | | | | | | | | | | | | | | | | | | | | | | | | | | | | | | | | | | | | | | | | | | | | | | | | | | | | | | | | | | | | | | | | | | | | | | | | | | | | | | | | | | | | | | | | | | | | | | | | | | | | | | | | | | | | | | | | | | | | | | | | | | | | | | | | | | | | | | | | | | | | | | | | | | | | | | | | | | | | | | | | | | | | | | | | | | | | | | | | | | | | | | | | | | | | | | | | | | | | | | | | | | | | | | | | | | | | | |
| | | | Base temp [F29] | (RW) | | | | | | | | | | | | | | | | | | | | | | | | | | | | | | | | | | | | | | | | | | | | | | | | | | | | | | | | | | | | | | | | | | | | | | | | | | | | | | | | | | | | | | | | | | | | | | | | | | | | | | | | | | | | | | | | | | | | | | | | | | | | | | | | | | | | | | | | | | | | | | | | | | | | | | | | | | | | | | | | | | | | | | | | | | | | | | | | | | | | | | | | | | | | | | | | | | | | | | | | | | | | | | | | | | | | | | | | | | | | | | | | | | | | | | | | | | | | | | | | | | | | | | | | | | | | | | | | | | | | | | | | | | | | | | | | | | | | | | | | | | | |
| | | | 1'st temp coeff * [F30] | (RW) | | | | | | | | | | | | | | | | | | | | | | | | | | | | | | | | | | | | | | | | | | | | | | | | | | | | | | | | | | | | | | | | | | | | | | | | | | | | | | | | | | | | | | | | | | | | | | | | | | | | | | | | | | | | | | | | | | | | | | | | | | | | | | | | | | | | | | | | | | | | | | | | | | | | | | | | | | | | | | | | | | | | | | | | | | | | | | | | | | | | | | | | | | | | | | | | | | | | | | | | | | | | | | | | | | | | | | | | | | | | | | | | | | | | | | | | | | | | | | | | | | | | | | | | | | | | | | | | | | | | | | | | | | | | | | | | | | | | | | | | | | | |
| | | | 2'nd temp coeff * [F31] | (RW) | | | | | | | | | | | | | | | | | | | | | | | | | | | | | | | | | | | | | | | | | | | | | | | | | | | | | | | | | | | | | | | | | | | | | | | | | | | | | | | | | | | | | | | | | | | | | | | | | | | | | | | | | | | | | | | | | | | | | | | | | | | | | | | | | | | | | | | | | | | | | | | | | | | | | | | | | | | | | | | | | | | | | | | | | | | | | | | | | | | | | | | | | | | | | | | | | | | | | | | | | | | | | | | | | | | | | | | | | | | | | | | | | | | | | | | | | | | | | | | | | | | | | | | | | | | | | | | | | | | | | | | | | | | | | | | | | | | | | | | | | | | |
| | | | Mass unit [F32] | (RW) | | | | | | | | | | | | | | | | | | | | | | | | | | | | | | | | | | | | | | | | | | | | | | | | | | | | | | | | | | | | | | | | | | | | | | | | | | | | | | | | | | | | | | | | | | | | | | | | | | | | | | | | | | | | | | | | | | | | | | | | | | | | | | | | | | | | | | | | | | | | | | | | | | | | | | | | | | | | | | | | | | | | | | | | | | | | | | | | | | | | | | | | | | | | | | | | | | | | | | | | | | | | | | | | | | | | | | | | | | | | | | | | | | | | | | | | | | | | | | | | | | | | | | | | | | | | | | | | | | | | | | | | | | | | | | | | | | | | | | | | | | | |
| | | | Time unit [F35] | (RW) | | | | | | | | | | | | | | | | | | | | | | | | | | | | | | | | | | | | | | | | | | | | | | | | | | | | | | | | | | | | | | | | | | | | | | | | | | | | | | | | | | | | | | | | | | | | | | | | | | | | | | | | | | | | | | | | | | | | | | | | | | | | | | | | | | | | | | | | | | | | | | | | | | | | | | | | | | | | | | | | | | | | | | | | | | | | | | | | | | | | | | | | | | | | | | | | | | | | | | | | | | | | | | | | | | | | | | | | | | | | | | | | | | | | | | | | | | | | | | | | | | | | | | | | | | | | | | | | | | | | | | | | | | | | | | | | | | | | | | | | | | | |
| | | End | | | | | | | | | | | | | | | | | | | | | | | | | | | | | | | | | | | | | | | | | | | | | | | | | | | | | | | | | | | | | | | | | | | | | | | | | | | | | | | | | | | | | | | | | | | | | | | | | | | | | | | | | | | | | | | | | | | | | | | | | | | | | | | | | | | | | | | | | | | | | | | | | | | | | | | | | | | | | | | | | | | | | | | | | | | | | | | | | | | | | | | | | | | | | | | | | | | | | | | | | | | | | | | | | | | | | | | | | | | | | | | | | | | | | | | | | | | | | | | | | | | | | | | | | | | | | | | | | | | | | | | | | | | | | | | | | | | | | | | | | | | | | |
| | | Not use | | | | | | | | | | | | | | | | | | | | | | | | | | | | | | | | | | | | | | | | | | | | | | | | | | | | | | | | | | | | | | | | | | | | | | | | | | | | | | | | | | | | | | | | | | | | | | | | | | | | | | | | | | | | | | | | | | | | | | | | | | | | | | | | | | | | | | | | | | | | | | | | | | | | | | | | | | | | | | | | | | | | | | | | | | | | | | | | | | | | | | | | | | | | | | | | | | | | | | | | | | | | | | | | | | | | | | | | | | | | | | | | | | | | | | | | | | | | | | | | | | | | | | | | | | | | | | | | | | | | | | | | | | | | | | | | | | | | | | | | | | | | | |
| | | Cable length * | [F52] | (RW) | | | | | | | | | | | | | | | | | | | | | | | | | | | | | | | | | | | | | | | | | | | | | | | | | | | | | | | | | | | | | | | | | | | | | | | | | | | | | | | | | | | | | | | | | | | | | | | | | | | | | | | | | | | | | | | | | | | | | | | | | | | | | | | | | | | | | | | | | | | | | | | | | | | | | | | | | | | | | | | | | | | | | | | | | | | | | | | | | | | | | | | | | | | | | | | | | | | | | | | | | | | | | | | | | | | | | | | | | | | | | | | | | | | | | | | | | | | | | | | | | | | | | | | | | | | | | | | | | | | | | | | | | | | | | | | | | | | | | | | | | | | |
| | | Temp damping * | [F50] | (RW) | | | | | | | | | | | | | | | | | | | | | | | | | | | | | | | | | | | | | | | | | | | | | | | | | | | | | | | | | | | | | | | | | | | | | | | | | | | | | | | | | | | | | | | | | | | | | | | | | | | | | | | | | | | | | | | | | | | | | | | | | | | | | | | | | | | | | | | | | | | | | | | | | | | | | | | | | | | | | | | | | | | | | | | | | | | | | | | | | | | | | | | | | | | | | | | | | | | | | | | | | | | | | | | | | | | | | | | | | | | | | | | | | | | | | | | | | | | | | | | | | | | | | | | | | | | | | | | | | | | | | | | | | | | | | | | | | | | | | | | | | | | |
| | | Analog out select * | [F55] | Method® | | | | | | | | | | | | | | | | | | | | | | | | | | | | | | | | | | | | | | | | | | | | | | | | | | | | | | | | | | | | | | | | | | | | | | | | | | | | | | | | | | | | | | | | | | | | | | | | | | | | | | | | | | | | | | | | | | | | | | | | | | | | | | | | | | | | | | | | | | | | | | | | | | | | | | | | | | | | | | | | | | | | | | | | | | | | | | | | | | | | | | | | | | | | | | | | | | | | | | | | | | | | | | | | | | | | | | | | | | | | | | | | | | | | | | | | | | | | | | | | | | | | | | | | | | | | | | | | | | | | | | | | | | | | | | | | | | | | | | | | | | | |

| | | | | | |
|----------|---|----------|----------|----------|----------|
| E | | | | | |
| Review | <table border="1" style="width: 100%; border-collapse: collapse;"> <tr><td>Review 1</td></tr> <tr><td>Review 2</td></tr> <tr><td>Review 3</td></tr> <tr><td>Review 4</td></tr> </table> | Review 1 | Review 2 | Review 3 | Review 4 |
| Review 1 | | | | | |
| Review 2 | | | | | |
| Review 3 | | | | | |
| Review 4 | | | | | |
| (MV) | | | | | |

| |
|--------------------|
| Pressure unit enum |
| MPa abs |
| kPa abs |
| kg/Sqcm abs |
| bar abs |
| psia |

F0810.ai

| Review 1 | Review 2 | Review 3 | Review 4 |
|----------------|-------------------|--------------------|-------------------|
| Model | Flow rate unit | Special unit | Function |
| Manufacturer | Flow span | User's unit | Base density |
| Distributor | PV Damp | Conversion factor | 1'st temp coeff |
| Tag | Contact output | Nominal size | 2'nd temp coeff |
| Descriptor | Pulse rate | Body type | Cable length |
| Message | Frequency at 100% | Sensor type | Temp damping |
| Date | Setting level | K-factor | Analog out select |
| Dev id | Upper display | Detector No | Temp 0% |
| Write protect | Lower display | User adjust | Temp 100% |
| AO Alrm typ | Total rate | Reynolds adjust | Temp error out |
| Universal rev | Total start/stop | Viscosity | (Only for /MV) |
| Fld dev rev | Fluid | Gas expansion fact | |
| Software rev | Process density | Flow adjust | |
| Hardware rev | Process temp | TLA | |
| Poll addr | Base temp | Signal level | |
| Burst mode | Process pressure | Noise balance mode | |
| Burst option | Base pressure | Noise ratio | |
| Num req preams | Deviation | High vib. | |
| | Low cut | Span velocity | |
| | Out limit (H) | Span frequency | |
| | Burn out | | |

F0811.ai

• DTM (HART 5) Menu Tree

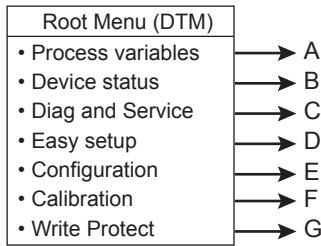

(R) Read only
 (CR) Continuous read
 (RW) Read and Write
 (M) Method of HCF
 [] Unique Method of DY
 (MV) Only for Multi-Variable Type

[] Parameter No. in display and BRAIN Terminal
 * Upload/Download
 ☆ Device revision 4.0 or later

A

| Process Variables | |
|-------------------|-----------|
| PV | [A20] (R) |
| PV % rng | [A10] (R) |
| AO1 | (R) |
| Flow span | [B10] (R) |
| PV damp | [B15] (R) |
| Total | [A30] (R) |
| (MV) Temp | [A41] (R) |
| (MV) TV % rng | [A40] (R) |
| (MV) AO3 | (R) |
| (MV) Temp 0% | [B51] (R) |
| (MV) Temp 100% | [B52] (R) |
| (MV) Temp damping | [F50] (R) |

B

| Device Status | |
|--------------------|-------------------------|
| Process Variables | |
| PV | [A20] (R) |
| PV % rng | [A10] (R) |
| (MV) TV % rng | [A41] (R) |
| (MV) Temp | [A40] (R) |
| Diagnostic List | |
| Device Status | (R) |
| Status group1 | (R) Status group 1 enum |
| Status group2 | (R) Status group 2 enum |
| (MV) Status group3 | (R) Status group 3 enum |

C

| Diag and Service | |
|------------------------|----------------------------|
| Loop test | (M) |
| Loop test pulse/status | (M) |
| Amplifier check | (M) |
| Test auto release time | [J40] (RW) ☆ |
| Master reset | (M) |
| Error Record | |
| Er record status 1 | (R) Er record group 1 enum |
| Er record status 2 | (R) Status group 2 enum |
| Er record status 3 | (R) Status group 3 enum |

D

| Easy Setup | |
|------------------------|------------|
| Tag | (RW) |
| Contact output | [B20] (R) |
| Contact output | (M) |
| Pulse rate | [B21] (R) |
| Freq at 100% | [B22] (R) |
| Setting level | [B23] (R) |
| Flow span | [B10] (RW) |
| (MV) Analog out select | [B50] (R) |
| (MV) Analog out select | (M) |
| Temp 0% | [B51] (R) |
| Temp 100% | [B52] (R) |
| PV Damp | [B15] (RW) |
| (MV) Temp damping | [F50] (RW) |
| Total rate | [B45] (RW) |
| Upper display | [B30] (RW) |
| Lower display | [B31] (RW) |

E

| Configuration | |
|---|------------------------|
| Meter | |
| Nominal size | [E10] (RW) |
| Body type | [E20] (RW) |
| Sensor type | [E30] (RW) |
| K-factor unit | [E40] (RW) |
| K-factor | [E41] (RW) |
| Detector No | [E50] (RW) |
| Cable length | [F52] (RW) |
| Upper display | [B30] (RW) |
| Lower display | [B31] (RW) |
| Flow Setting | |
| (MV) Sensor status | (R) |
| (MV) Function | (R) |
| (MV) Function | (M) |
| Fluid | (R) |
| Fluid | (M) |
| Indicate parameter depends on the choice in 'Fluid/Function'. | |
| Special Units | |
| Special unit | [D40] (R) |
| Special unit | (M) |
| Base unit | [D41] (R) |
| User's unit | [D42] (R) |
| Conversion factor | [D43] (R) |
| Total | |
| Total | [A30] (R) |
| Total start/stop | [B40] (RW) |
| Total rate | [B45] (RW) |
| Total reset | (M) |
| Adjust | |
| User adjust | [H20] (RW) |
| Raynolds adjust | [H25] (R) |
| Raynolds adjust | (M) |
| Process density | [K36] (R) |
| Gas expansion fact | [H30] (RW) |
| Flow adjust | [H40] (R) |
| Flow adjust | (M) |
| Indicate parameter only when 'Flow adjust' is activated. | |
| Maintenance | |
| Lowcut | [D20] (RW) |
| TLA | [K10] (RW) |
| Signal level | [K20] (RW) |
| Noise balance mode | [K25] (R) |
| Noise balance mode | (M) |
| Noise ratio | [K26] (R) |
| High vibration | [K45] (RW) |
| Velocity | [K30] (R) |
| Span Velocity | [K32] (R) |
| Vortex frequency | [K34] (R) |
| Span frequency | [K36] (R) |
| Menu type number | (RW) |
| Analog Output | |
| Flow span | [B10] (RW) |
| PV Damp | [B15] (RW) |
| AO Arim typ | (R) |
| Out limit(H) | [D30] (RW) |
| (MV) Analog out select | [B50] (R) |
| (MV) Analog out select | (M) |
| (MV) Temp damping | [F50] (RW) |
| Device information | |
| Model | (R) |
| Manufacturer | (R) |
| Hardware rev | (R) |
| Software rev | (R) |
| Descriptor | (RW) |
| Message | (RW) |
| Date | (RW) |
| Final asmbly num | (RW) |
| HART | |
| Tag | (RW) |
| Poll addr | (RW) |
| Dev id | (R) |
| Universal rev | (R) |
| Fid dev rev | (R) |
| Next universal rev | (R) ☆ |
| Chng universal rev | (M) ☆ |
| Num req preams | (R) |
| Physical signl code | (R) |
| Burst mode | (RW) Burst mode enum |
| Burst option | (RW) Burst option enum |

F

| Calibration | |
|-----------------|-----|
| D/A trim | (M) |
| Scaled D/A trim | (M) |

G

| Write Protect | |
|---------------|-----|
| write protect | (M) |
| Software seal | (R) |

F0814.ai

9. OPERATION VIA HART CONFIGURATION TOOL (HART 7)



NOTE

In this User's Manual, HART protocol revision 5 and 7 are described as HART 5 and HART 7 respectively.

Note: HART is a registered trademark of the HART Communication Foundation (HCF).

9.1 HART Protocol Revision

For the models with the output signal code “-J”, HART protocol revision 5 or 7 is selectable. The protocol revision is set as specified in the order.

- Confirmation by the name plate
The HART protocol revision is shown by the last number of the serial number.

In the case of the communication code “-J”

The HART protocol revision is shown by the last number of the serial number.

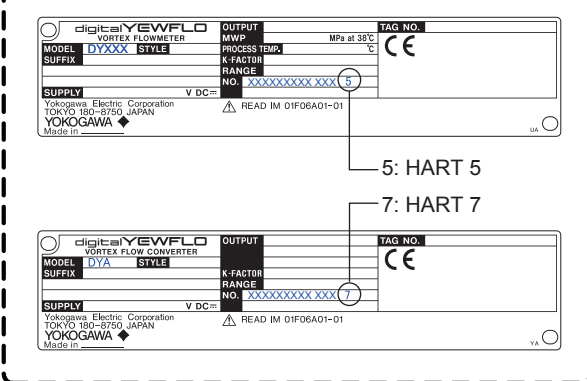

F0901.ai

Figure 9.1 Name Plate

9.2 HART Configuration Tool and Matching of Device Revision

Before using the HART Configuration Tool (such as FieldMate), confirm that the DD (Device Description) of the digitalYEWFLO is installed in the Configuration Tool before using.

DY and DYA HART 7;

Device type: 0x370B, Device revision: 10



IMPORTANT

Protocol revision supported by HART configuration tool must be the same or higher than that of the device.

| | Protocol Rev. supported by HART configuration tool | |
|------------------|--|-----------|
| | 5 | 7 |
| DY or DYA HART 5 | Available | Available |
| DY or DYA HART 7 | Not available | Available |

The DD revisions for digitalYEWFLO and Configuration Tool's can confirm in accordance with the following steps.

If the correct DD is not installed in the HART Configuration Tool, download them from the official HART programming sites, otherwise, contact the respective vendors of the Configuration Tool for its upgrade information.

- Confirmation of the device revision for digitalYEWFLO
 - Procedure to callup the field device revision; **[Root Menu]** → Review → Review1
 - 'Fld dev rev' in the Review1 shows the revision number of correspondent field device.
- Confirmation of the device revision for the HART Configuration Tool

- Confirm the installed DD revision in accordance with the procedure of the Configuration Tool. Read its manual how to confirm it in detail.

The first 2 digits of the DD file are expressed the device revision, and its last 2 digits are expressed the DD revision.

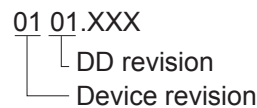

F0902.ai

9.3 Setting Parameters using DTM

When configure the parameters using FieldMate, use the DTM (Device Type Manager) referring to the following table.

| DTM Name | Device Type | Device Revision |
|----------------|-------------|-----------------|
| DYF HART 7 DTM | 0 x 370B | 10 |

9.4 Interconnection between digitalYEWFLO and HART Configuration Tool

The HART Configuration Tool can interface with the digitalYEWFLO from the control room, the digitalYEWFLO site, or any other wiring termination point in the loop, provided there is a minimum load resistance of 250 Ω between the connection and the receiving instrument. To communicate, it must be connected in parallel with the digitalYEWFLO, and the connections must be non-polarized. Figure 9.2 illustrates the wiring connections for a direct interface at the digitalYEWFLO site. The HART Configuration Tool can be used for remote access from any terminal strip as well.

In case of general type (non-ex) and flameproof type:

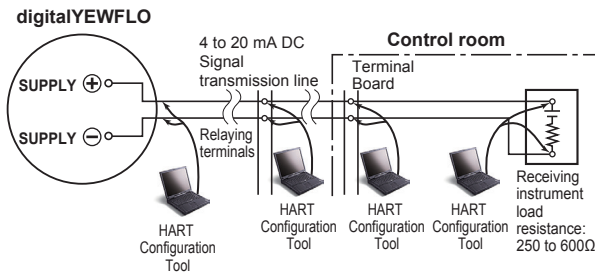

In case of intrinsically safe type:

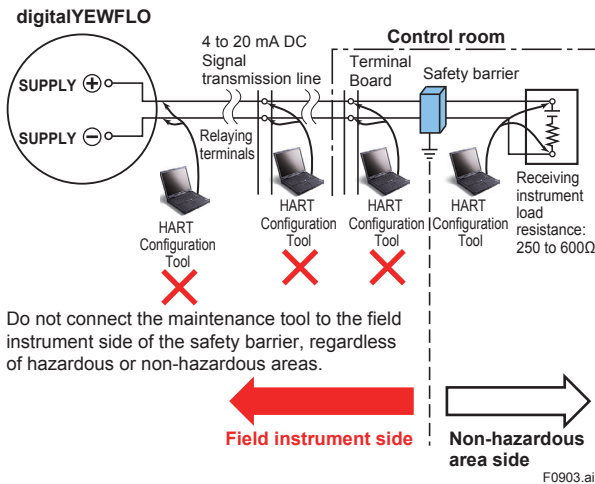

Figure 9.2 Connecting the HART Communicator

WARNING

Be sure to set parameters as “Protect” on the write protect function after finish of parameter setting work.

Read Section 9.9 “Software Write Protect” how to use the write protect function in detail.

IMPORTANT

If the power of flowmeter is turned off within 30 seconds after parameters have been set, these settings will be canceled. Accordingly, please keep the power on for at least 30 seconds after setting parameters.

NOTE

Before updating any setting, remember to always check the data content you want to change as described in Section 6.4 “Parameters Description”.

9.5 Basic Setup

■ Tag and Device Information

The tag number and device information can be checked as follows:

- Procedure to call up the tag number and device information

| | |
|------------|---|
| Tag | [Root Menu] → Basic setup → Tag or [Root Menu] → Detailed setup → Device information → Tag or [Root Menu] → Review → Review1 → Tag |
| Long Tag | [Root Menu] → Basic setup → Long Tag or [Root Menu] → Detailed setup → Device information → Long Tag or [Root Menu] → Review → Review1 → Long Tag |
| Descriptor | or [Root Menu] → Detailed setup → Device information → Descriptor or [Root Menu] → Review → Review1 → Descriptor |
| Message | or [Root Menu] → Detailed setup → Device information → Message or [Root Menu] → Review → Review1 → Message |
| Date | or [Root Menu] → Detailed setup → Device information → Date or [Root Menu] → Review → Review1 → Date |

When changing the tag number or device information, enter the information directly within the following limitations.

| Item | Limitations |
|------------------------|--|
| Tag | Up to 8 characters or numbers ^{*1} |
| Long Tag (HART 7 only) | Up to 32 characters or numbers ^{*2} |
| Descriptor | Up to 16 characters or numbers ^{*1} |
| Message | Up to 32 characters or numbers ^{*1} |
| Date | yyyy/mm/dd - mm : month (2 digits) - dd : days (2 digits) - yy : years (2 digits) |

*1: The characters bounded by the thick line in the following table can be used.

*2: All characters in the following table can be used.

| | | | | | | | | | | | | | | | |
|-------|---|---|---|----|---|---|---|---|---|---|---|---|---|---|---|
| SPACE | ! | " | # | \$ | % | & | ' | (|) | * | + | , | - | . | / |
| 0 | 1 | 2 | 3 | 4 | 5 | 6 | 7 | 8 | 9 | : | ; | < | = | > | ? |
| @ | A | B | C | D | E | F | G | H | I | J | K | L | M | N | O |
| P | Q | R | S | T | U | V | W | X | Y | Z | [| \ |] | ^ | _ |
| ` | a | b | c | d | e | f | g | h | i | j | k | l | m | n | o |
| p | q | r | s | t | u | v | w | x | y | z | { | | } | ~ | |

F0904.ai

9.6 Parameter Setting

The parameter structure of the HART configuration tool is hierarchical.

Read Section 9.11 "Menu Tree (HART 7)" for the corresponding parameters. The menu tree shows a cross-reference of the parameters for HART configuration Tool and BRAIN Terminal.

Read Section 6.4 "Parameters Description" for the functions of parameters.

Note that some display parameters of digitalYEWFO are different from those of HART Configuration Tools.

9.7 Data Renewing and Upload/Download function

(1) Data renewing

Following data are renewed in 0.5 to 2 seconds cycle.

PV, PV%, mge, Loop Current, Total Temp, TV% mge, : only for /MV

(2) Upload/download function

Upload/download parameters from digitalYEWFO to the HART Configuration Tool.

Read Section 9.11 "Menu Tree (HART 7)" for the applicable parameters.

9.8 Self-Diagnostic

The self-diagnostic function of the digitalYEWFO is explained in Section 6.5 "Self-Diagnostic (Error Code List)".

The followings are additional items of the self-diagnostic function.

- Burst configuration error: Burst mode setting error.
- Device variable simulation: Executing Device variable simulation function.

The HART configuration tool is able to execute METHOD (*) of 'Self test/Status'. Confirm the error.

- Procedure to call up the Self test/Status;

[Root Menu] → Diag/Service → Self test/Status

(*) 'Method' is a program to facilitate the parameter settings.

9.9 Software Write Protect

digitalYEWFL0 configured data is saved by using a write protect function. The write protect status is set to "Yes" when 8 alphanumeric characters are entered in the **New password** field and transferred to the device. When write protect is set to "Yes," the device does not accept parameter changes. When the same eight alphanumeric string entered in the **New password** field is also entered in the **Enable wrt 10min** field and transferred to the digitalYEWFL0, it will be possible to change device parameters during a 10 minute period.

To change the digitalYEWFL0 from the write protect "Yes" status back to Write protect "No" status, use **Enable wrt 10min** to first release the write protect function and then enter eight spaces in the **New password** field.

9.10 Specific Functions of HART Configuration Tool

9.10.1 Process Variable Setup (Dynamic Variables)

The device deals with four data (flow rate, temperature, density and total flow rate). In case of /MV, these four data are allocated to PV(Primary Variable), SV(Secondary Variable), TV(Tertiary Variable) and QV(Quaternary Variable). The variable of PV is 4 to 20mA current output. Therefore, the total flow rate do not allocate to PV. (Except /MV, each dynamic variables are fixed at factory setting.)

| Dynamic Variable | Choice items | Factory Setting |
|------------------|--|------------------------|
| PV | Flow rate, Temperature | Instantaneous Flowrate |
| SV | Flow rate, Total, Temperature, Density | Total Flowrate |
| TV | Flow rate, Total, Temperature, Density | Fluid Temperature |
| QV | Flow rate, Total, Temperature, Density | Fluid Density |

- Procedure to call up the Dynamic variable assignments.

[Root Menu] → Detailed setup → Configure outputs → HART output →

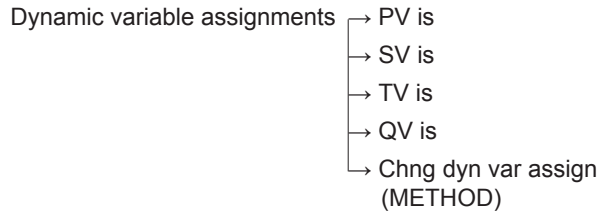

F0905.ai

Update time period of each measurement value is as follows;

- Flow rate: Flow rate Update time period
- Total: Total Update time period
- Temperature: Temperature Update time period
- Density: Density Update time period

9.10.2 Burst Mode

When the **Burst mode** is enabled, the device continuously sends up to three data listed in Table 9.1.

When the **Burst mode** is set to “Wired HART Enabled”, the device continuously sends alarm signal also.

Read Subsection 9.10.3 “Event Notification” for detail.

When changing the setting of **Burst mode**, set “Off” to the **Burst mode**. Default setting is “Off”.

(1) Burst Message

The parameters for Burst Message are as follows.

- Transmit data: command parameters of Burst Command
- Device variables:
- Update period
- Transmit condition: choice in Burst Msg Trigger Mode

Read Table 9.1 for the combination between command parameter and transmit condition.

[Root Menu] → Detailed setup → Configure outputs → HART output → Burst Condition → Burst Message1, 2, 3 → Burst command



NOTE

- In case of Burst Mode setting change, confirm Burst Mode parameter is OFF.
- Prioritize to use the 'Burst Message 1'.

Table 9.1 Burst parameters

| Command parameter | Burst Command | Burst Msg Trigger Mode | Burst Trigger Source | Burst Trigger Units |
|--|--|------------------------|-------------------------------|---|
| PV (flow rate) | Cmd1:PV | Continuous | — | — |
| | | Window | PV | Depends on the assigned variable to PV |
| | | Rising | | |
| | | Falling | | |
| | | On-change | | |
| % range/current (Percent of range, Loop current) | Cmd2:% range/ current | Continuous | — | — |
| | | Window | % range | % |
| | | Rising | | |
| | | Falling | | |
| | | On-change | | |
| Process vars/current (Loop current, PV, SV, TV, QV) | Cmd3:Dyn vars/ current | Continuous | — | — |
| | | Window | PV | Depends on the assigned variable to PV |
| | | Rising | | |
| | | Falling | | |
| | | On-change | | |
| Process vars/%range/current with status*1 (Select from flow rate, total flow, temperature, density, percent of range, loop current, PV, SV, TV, and QV)*2 | Cmd9:Device vars w/ Status | Continuous | — | — |
| | | Window | Top of Burst Device Variables | Depends on maapping |
| | | Rising | | |
| | | Falling | | |
| | | On-change | | |
| Process vars/%range/current (Select from flow rate, total flow, Temperature, Density, percent of range, loop current, PV, SV, TV, and QV)*2 | Cmd33:Device Variables | Continuous | Top of Burst Device Variables | Depends on the assigned variable to Burst Device Variable |
| | | Window | | |
| | | Rising | | |
| | | Falling | | |
| | | On-change | | |
| Self diagnosis information | Cmd48:Read Additional Device Status | Continuous | — | — |
| | | On-change | All status | — |

*1: Output the data with time and status.

*2: Select at **Burst Device Variables**

(2) Burst mode setting procedure

- Procedure to call up the display

| | |
|-----------------------------|---|
| DD (HART 7) DTM (HART 7) | [Root Menu] → Detailed setup → Configure outputs → HART output → Burst Condition → Burst Message 1,2 or 3 → Burst Command |
|-----------------------------|---|

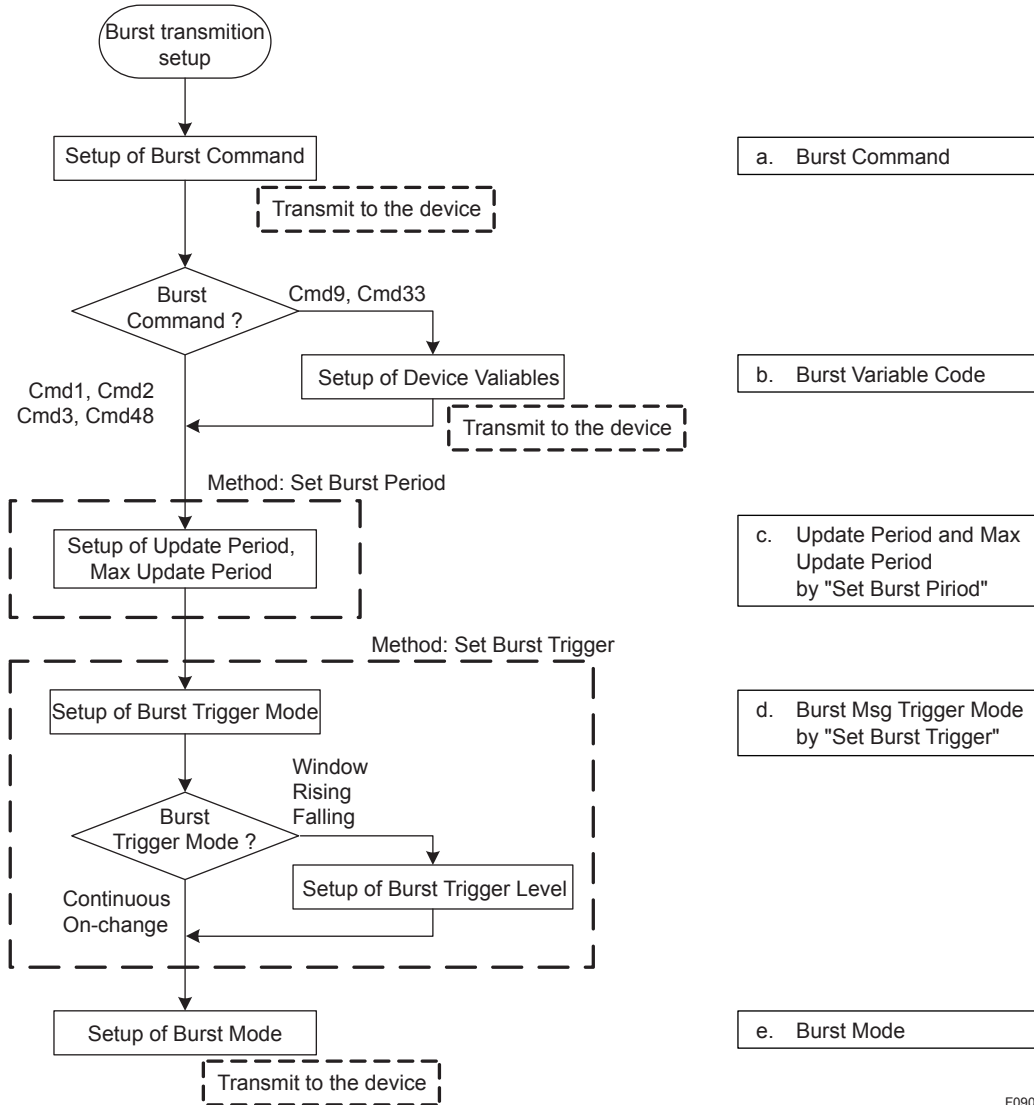

F0906.ai

a. Burst Command

Select the transmission data at **Burst Command** parameter.

| Burst Command | Command parameter |
|-------------------------------------|---|
| Cmd1:PV | Variable assigned to PV |
| Cmd2:% range/current | % range/current (Percent of rang, Loop current) |
| Cmd3:Dyn vars/current | Process vars/current (Loop current, PV, SV, TV, QV) |
| Cmd9:Device vars w/Status | Process vars/% range/current Mapping by user |
| Cmd33:Device Variables | Process vars/% range/current Mapping by user |
| Cmd48:Read Additional Device Status | Self diagnosis information |

b. Burst Variable Code

This parameter is possible to be set when **Burst Command** is Cmd9:Device vars w/Status (up to eight items) and Cmd33: Device Variables (up to four items).

Set device variables to a bare minimum to avoid to get the communication time longer.

- Procedure to call up the display

| DD (HART 7) DTM (HART 7) | [Root Menu] → Detailed setup → Configure outputs → HART output → Burst Condition → Burst Message1, 2 or 3 → Burst Device Variables → Burst Variable Code → |
|-----------------------------|--|
| Display Item | Contents |
| Flowrate | Flowrate |
| Total | Total flow |
| Temperature | Temperature |
| Density | Density |
| %rnge | Select the % output |
| Loop current | Select the output current |
| PV | Select the PV value |
| SV | Select the SV value |
| TV | Select the TV value |
| QV | Select the QV value |
| Not use | — |

c. Update Period and Max Update Period

Set to **Update Period** and **MaxUpdate Period**. Set greater value of update period than a value which is set in each process value.

For **Update Period**, set the value that is smaller than **Max Update Period**.

- Procedure to call up the display

| | |
|---|--|
| DD (HART 7) DTM (HART 7) | [Root Menu] → Detailed setup → Configure outputs → HART output → Burst Condition → Burst Message1, 2 or 3 → Set Burst Period → |
| → Update Period /Max Update Period | 0.5 s |
| | 1 s |
| | 2 s |
| | 4 s |
| | 8 s |
| | 16 s |
| | 32 s |
| | 1 min |
| | 5 min |
| | 10 min |
| | 15 min |
| | 30 min |
| | 45 min |
| 60 min | |

d. Burst Msg Trigger Mode

Set The **Burst Msg Trigger Mode** from the parameters shown below.

When **Burst Msg Trigger Mode** is Window, Rising or Falling, set the **Burst Trigger Level**.

- Procedure to call up the display

| DD (HART 7) DTM (HART 7) | [Root Menu] → Detailed setup → Configure outputs → HART output → Burst Condition → Burst Message1, 2 or 3 → Set Burst Trigger → |
|-----------------------------|---|
| Display Item | Contents |
| Continuous | Burst Message is transmitted contiuously. |
| Window | It detects that the absolute value of the amount of change of a device variable value became beyond the preset value of Burst Trigger Level, and transmits. |
| Rising | It detects that the device variable value became beyond the preset value of Burst Trigger Level, and transmits. |
| Falling | It detects that the device variable value turned into below the preset value of Burst Trigger Level, and transmits. |
| On-change | It detects that the device variable value changed and transmits. |

*1: Check transmitting conditions with the cycle set as Update Period, and when it corresponds to conditions, they transmit. Moreover, even if it does not correspond to conditions, it transmits compulsorily with the cycle set up by Max Update Period.

e. Burst Mode

When the **Burst mode** is set to Wired HART Enabled, the device starts to send the data.

- Procedure to call up the display

[Root Menu] → Detailed setup → Configure outputs → HART output → Burst condition → Burst Message1, 2 or 3 → Burst mode → Wired HART Enabled

9.10.3 Event Notification

When a setting change and a change of the Self-diagnostics occur, device detect it as an event and can transmit an alarm signal continuously.

Alarm contained in the following item can be set to Event, and can be detected.

- Device Status
- Status group 1 to 3
- Ext dev status
- Device diagnostic status 0

Up to four events that occurred can be stored.

When using this function, set to **Burst mode** as “Wired HART Enabled”.

(1) Set Event Notification

- Procedure to call up the display

| | |
|---------------------------------|--|
| DD (HART 7) DTM (HART 7) | [Root Menu] → Detailed setup → Configure outputs → HART output → Event Notification |
| → Event Notification Control | Stop the event monitor: OFF Shift to the monitor state: Enable event notification on token-passing data link layer |
| → Event Mask | Set the status to detect |
| → Event Notification Retry Time | Set the retry time when the event occur. |
| → Max Update Time | Set the retry time when the event does not occur. |
| → Event Debounce Interval | The setting of the minimum event duration |

a) Event Mask

Set the status to detect in the **Event Mask** parameter.

| |
|---------------------------------|
| Device Status Mask |
| Status group 1 to 3 |
| Ext dev status Mask |
| Device Diagnostic Status 0 Mask |

b) Event Notification Retry Time/ Max Update Time/ Event Debounce Interval

Set to Event Notification Retry Time, Max Update Time and Event Debounce Interval.

For **Event Notification Retry Time**, set the value that is smaller than **Max Update Time**.

| Event Notification Retry Time/Max Update Time | Event Debounce Interval |
|---|-------------------------|
| — | Off |
| 0.5 s | 0.5 s |
| 1 s | 1 s |
| 2 s | 2 s |
| 4 s | 4 s |
| 8 s | 8 s |
| 16 s | 16 s |
| 32 s | 32 s |
| 1 min | 1 min |
| 5 min | 5 min |
| 10 min | 10 min |
| 15 min | 15 min |
| 30 min | 30 min |
| 45 min | 45 min |
| 60 min | 60 min |

c) Event Notification Control

Select “Enable event notification on token-passing data link layer” in the **Event Notification Control** parameter to shift to the monitor state:

(2) Acknowledge Event Notification (DTM)

The transmission of the event message stops when event is approved.

- Procedure to call up the display

| | |
|----------------------------------|---|
| DTM (HART 7) | [Root Menu] → Detailed setup → Configure outputs → HART output → Event Notification → Knowledge → |
| → Acknowledge Event Notification | Acquisition of the event number and approval. |

a) Get Event Number

Confirm the latest event number.

Execute **Acknowledge Event Notification** method.

- 1) Set “0” to enter Event Number.
- 2) OK.
- 3) Set “Trans 0: Read Event Notification” to Select Transaction.
- 4) OK.
- 5) Confirm Event Number.

b) Acknowledge Event Notification

Execute **Acknowledge Event Notification** method.

- 1) Set the event number which is confirmed in a)5 to enter Event Number.
- 2) OK.
- 3) Set “Trans 1: Send Acknowledge” to Select Transaction.
- 4) OK.
- 5) Confirm Event Status is 0x00.

(3) Event Notification Record (DTM)

- Procedure to call up the display

| | |
|----------------------------------|--|
| DTM (HART 7) | [Root Menu] → Detailed setup → Configure outputs → HART output → Event Notification → Knowledge → |
| → Acknowledge Event Notification | Acquisition of the event number and approval. |

a) Get Event Number

Confirm the latest event number.

Execute **Acknowledge Event Notification** method.

- 1) Set “0” to enter Event Number.
- 2) OK.
- 3) Set “Trans 0: Read Event Notification” to Select Transaction.
- 4) OK.
- 5) Confirm Event Number.

b) Confirmation record of Event Notification

Confirm four events checked in a).

- 1) Set the event number which is confirmed in a)5 to enter Event Number.
- 2) OK.
- 3) Set “Trans 0: Read Event Notification” to Select Transaction.
- 4) OK.
- 5) Knowledge menu displays events record.

Ex.) When the confirmed event number is 123.

| Event Number | Explanation |
|--------------|------------------------------|
| 123 | The latest event |
| 122 | An event before the once. |
| 121 | An event before the twice. |
| 120 | An event before three times. |

9.10.4 Multidrop Mode

“Multidroping” devices read the connection of several devices to a single communication transmission line. Up to 63 devices can be connected when set in the multidrop mode. To activate multidrop communication, the device address must be changed to a number from 1 to 63. If it sets to multidrop mode, in order to transmit all the data in digital one, it is necessary to change a setup of the analog signal output of four to 20 mA.

Setting of Multidrop Mode

(1) Polling address

- Procedure to call up the display

| | |
|--------------|---------------------------------------|
| DD (HART 7) | [Root Menu] → Detailed setup → |
| DTM (HART 7) | Configure outputs → HART output → |
| → Poll addr | Enter the number from 1 to 63 |

(2) Enabling the Multidrop Mode

About the procedure to call up the **Polling** display, read the User’s Manual of each configuration tool.

Usually, set Disable to Loop current mode and fix an analog output signal to 4mADC. It becomes impossible in this case, to also use a burnout output.

However, in the case of the application which receives and operates an analog output signal, an analog output signal can be used for one loop to variable one set, setting it up. In this case, set Enable to Loop current mode.

- Procedure to call up the display

| | |
|--------------|---|
| DD (HART 7) | [Root Menu] → Detailed setup → |
| DTM (HART 7) | Configure outputs → Analog output → Loop current mode → |
| Enabled | Loop current mode is enabled. |
| Disabled | Loop current mode is disabled. |



NOTE

When the same polling address is set for two or more devices in multidrop mode, communication with these devices are disabled.

- (3) Communication when set in the multidrop mode.
 - The HART configuration tool searches for a device that is set in multidrop mode when it is turned on. When the HART configuration tool is connected to the device, the polling address and the tag will be displayed.
 - Select the desired device. After that, normal communication to the selected device is possible. However, the communication speed will be slow.
- (4) Release the Multidrop Mode
 To release multidrop mode, call up the **Poll addr** display and set the address to "0".
 Return Loop current mode to Enable.

9.10.5 Loop Test, Simulation, and Squawk

(1) Loop test

This feature can be used to output a fixed current for loop checks.

- Procedure to call up the Loop test (Method)
[Root Menu] → Diag/Service → Loop test

(2) Device Variable Simulation Function (Effective only when setting to HART 7)

Using the simulation function, the output signal can be confirmed by setting any value and status to the selected device variable.

Call up the parameter (Method) and follow the message shown.

After completing the step 5 in the next table, the simulation starts.

- Procedure of device variable simulation

| | | |
|-------|------------------------------|--|
| step1 | Call up the parameter | [Root Menu] → Diag/Service → Simulate (M) |
| 2 | Selection of Device Variable | Select one parameter from the list below Off Flow rate Total Temperature Density Percent range Loop Current |
| 3 | Setting of Value | Input the simulate value |
| 4 | Setting of Data quality | Select one parameter from the list below Bad Poor accuracy Manual / Fixed Good |
| 5 | Setting of Limit status | Select one parameter from the list below Not limited Low limited High limited Constant |



NOTE

- The simulations act on current, LCD display, communication and alarm.
- The simulation of total flow rate acts on LCD display and communication, not on measuring total flow rate.
 The measuring total flow rate is continuously working during simulation.

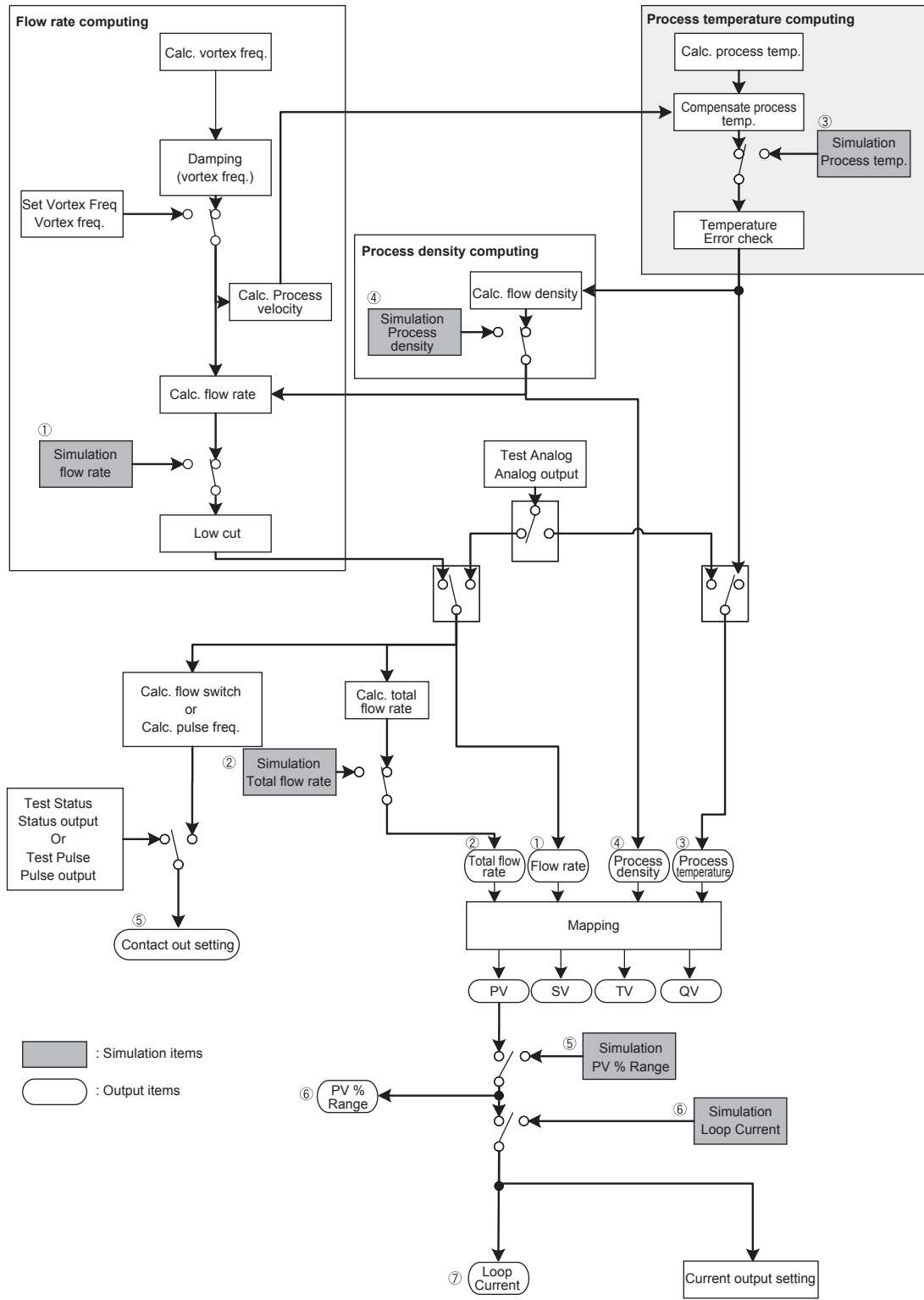

F0907.ai

Figure 9.3 Simulation Flow

- Simulation Setting and Correlation of Output Value

<Case A>: Without option code /MV

| Simulation Setting value | Output value | | | | | | |
|--------------------------|--------------|------------------|----------------------|------------------|-----------------|-------------|---------------|
| | Flow rate① | Total flow rate② | Process temperature③ | Process density④ | Contact output⑤ | PV % Range⑥ | Loop Current⑦ |
| Flow rate | Yes | Yes | No | No | Yes | Yes | Yes |
| Total flow rate | No | Yes | No | No | No | No | No |
| Process temperature | No | No | Yes | No | No | No | No |
| Process density | No | No | No | Yes | No | No | No |
| PV % Range | No | No | No | No | No | Yes | Yes |
| Loop Current | No | No | No | No | No | No | Yes |

Yes : Simulation value or calculation result of Simulation.

No : Actual process value or parameter setting value.

<Case B>: With option code /MV

<Case B-1>: Function == "Monitor only"

<Case B-2>: Function == "Saturated Steam" or "Superheat Steam" or "LIQUID:Mass"

<Case B-3>: Function == "Gas:STD/Normal"

<Case B-4>: Function == "Not use"

| Simulation Setting value | Output value | | | | |
|--------------------------|------------------------|------------------------|---------------------|----------------------|------------------------|
| | Flow rate | Total flow rate | Process temperature | Process density | Contact output |
| Flow rate | Yes | Yes | No | No | Yes |
| Total flow rate | No | Yes | No | No | No |
| Process temperature | <Case B-1, 4> No | <Case B-1, 4> No | Yes | <Case B-1, 2> Yes | <Case B-1, 4> No |
| | <Case B-2, 3> Yes | <Case B-2, 3> Yes | | <Case B-3, 4> No | <Case B-2, 3> Yes |
| Process density | <Case B-1, 3, 4> No | <Case B-1, 3, 4> No | No | Yes | <Case B-1, 3, 4> No |
| | <Case B-2> Yes | <Case B-2> Yes | | | <Case B-2> Yes |
| PV % Range | No | No | No | No | No |
| Loop Current | No | No | No | No | No |

| Simulation Setting value | Output value | | | |
|--------------------------|--------------------------|------------------------|-----------------------------|-----------------------------|
| | PV= Instaneous flow rate | | PV= Process temperature | |
| | PV % Range | Loop Current | PV % Range | Loop Current |
| Flow rate | Yes | Yes | <Case B-1, 2, 3> No | <Case B-1, 2, 3> No |
| | | | <Case B-4> Not available | <Case B-4> Not available |
| Total flow rate | No | No | <Case B-1, 2, 3> No | <Case B-1, 2, 3> No |
| | | | <Case B-4> Not available | <Case B-4> Not available |
| Process temperature | <Case B-1, 4> No | <Case B-1, 4> No | <Case B-1, 2, 3> Yes | <Case B-1, 2, 3> Yes |
| | <Case B-2, 3> Yes | <Case B-2, 3> Yes | <Case B-4> Not available | <Case B-4> Not available |
| Process density | <Case B-1, 3, 4> No | <Case B-1, 3, 4> No | <Case B-1, 2, 3> No | <Case B-1, 2, 3> No |
| | <Case B-2> Yes | <Case B-2> Yes | <Case B-4> Not available | <Case B-4> Not available |
| PV % Range | Yes | Yes | <Case B-1, 2, 3> Yes | <Case B-1, 2, 3> Yes |
| | | | <Case B-4> Not available | <Case B-4> Not available |
| Loop Current | No | Yes | <Case B-1, 2, 3> No | <Case B-1, 2, 3> Yes |
| | | | <Case B-4> Not available | <Case B-4> Not available |

(3) Squawk (Effective only when setting to HART 7)

This feature can be used to identify the communicating device by remotely causing LCD to display the particular pattern as shown in the Figure 9.4

“SQUAWK” continues for approximately 10 seconds, then is released automatically.

- Procedure to call up the **Squawk** display

[Root Menu] → Diag/Service → Squawk(Method)

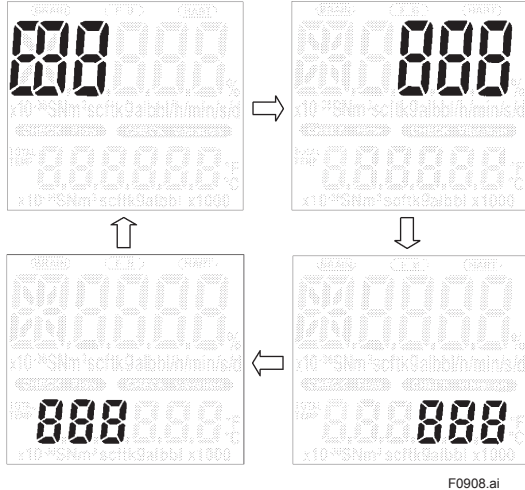

Figure 9.4 Display for Squawk

9.10.6 Switching HART Protocol Revision

When the output signal code is “-J”, HART protocol revision of the device can be selectable from 5 or 7. The HART protocol revision is set and shipped as specified in the order.

To change the HART protocol revision after shipment, follow the procedure shown below.

IMPORTANT

When change the protocol revision, confirm the items below.

- Protocol revision supported by HART configuration tool must be the same or higher than new protocol revision of the device. (Read Section 9.1 “HART Protocol Revision”)
- Confirm that the DD or DTM which is suitable to new protocol revision of the device is installed in the configuration tool. (Read Section 9.2 “HART Configuration Tool and Matching of Device Revision” and Section 9.3 “Setting Parameters using DTM”)

- (1) Call up the parameter for protocol revision change

- Procedure to call up the **Chng universal rev** display.

| | |
|-------------------------------|---|
| DD (HART 5/7) DTM (HART 7) | [Root Menu] → Detailed setup → Device information → Revision numbers → Chng universal rev |
| DTM (HART 5) | [Root Menu] → Configuration → HART → Chng universal rev |

- (2) Activate the “Chng universal rev” method

IMPORTANT

The message is displayed to separate the device from the automatic control loop.

Confirm that the device is separated.

- (3) Input the new revision number

An input column for new protocol revision number is displayed. Input the new HART protocol revision number of “5” for HART 5 or “7” for HART 7.

It checks that the revision number which it is going to change into the Next universal rev column is displayed.

[Root Menu] → Detailed setup → Device information → Revision numbers → Next universal rev

- (4) Applying the new protocol revision

- a. Close the configuration tool
After completion of Chng universal rev method, close the HART configuration tool.

NOTE

When using a FieldMate, close the main display of FieldMate.

- b. Restart the device
Turn off the power to the device, and turn it on.

IMPORTANT

New protocol revision is applied only after having performed restart of the device.



NOTE

A new HART revision number is displayed on the integral indicator for three seconds after restart the device. (Read Section 9.2 “HART Configuration Tool and Matching of Device Revision”)

- (5) Confirming the new protocol revision
 - a. Restart the HART configuration tool



NOTE

When execute the other parameter confirmation or setting change, execute after restart the configuration tool.

- b. Confirm the new HART protocol revision number

Call up the **Universal rev** parameter, and confirm that the new HART revision number is displayed.

- Procedure to call up the **Universal rev** parameter.

| | |
|-------------------------------|--|
| DD (HART 5/7) DTM (HART 7) | [Root Menu] → Detailed setup → Device information → Revision numbers → Universal rev → |
| DTM (HART 5) | [Root Menu] → Configuration → HART → Universal rev. → |
| 5 | HART protocol revision: 5 |
| 7 | HART protocol revision: 7 |

9.10.7 Other Operations for the HART Configuration Tool

Regarding other operations for the HART Configuration Tool, read the HART Configuration Tool operations manual.

9.11 Menu Tree (HART 7)

• DD (HART 7) Menu Tree



• DTM (HART 7) Menu Tree

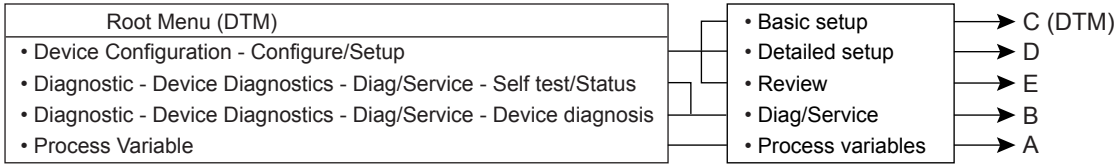

F0909.ai

(R) Read only [] Parameter No. in display and BRAIN Terminal.
 (CR) Continuous read * Upload/Download
 (RW) Read and Write
 (M) Method of HCF
 Unique Method of DY
 (MV) Only for Multi-Variable Type

A

| | | |
|------------------------|---------------------------|------------------------|
| Process variables | | |
| Flow rate | [A20] | (CR) |
| Total | [A30] | (CR) |
| Temp | [A41] | (CR) |
| %rnge | [A10] | (CR) |
| Loop Current | | (CR) |
| Device variable status | | |
| | Flow rate Data Quality | (CR) Data quality enum |
| | Flow rate Limit Status | (CR) Limit status enum |
| | Total Data Quality | (CR) Data quality enum |
| | Total Limit Status | (CR) Limit status enum |
| | Temp Data Quality | (CR) Data quality enum |
| | Temp Limit Status | (CR) Limit status enum |
| | %rnge Data Quality | (CR) Data quality enum |
| | %rnge Limit Status | (CR) Limit status enum |
| | Loop Current Data Quality | (CR) Data quality enum |
| | Loop Current Limit Status | (CR) Limit status enum |
| Time Stamp | | (CR) |
| Data quality enum | | |
| Bad | | |
| Poor accuracy | | |
| Manual / Fixed | | |
| Good | | |
| Limit status enum | | |
| Not limited | | |
| Low limited | | |
| High limited | | |
| Constant | | |

F0910.ai

- (R) Read only
 - (CR) Continuous read
 - (RW) Read and Write
 - (M) Method of HCF
 - Unique Method of DY
 - (MV) Only for Multi-Variable Type
- [] Parameter No. in display and BRAIN Terminal.
 * Upload/Download

B

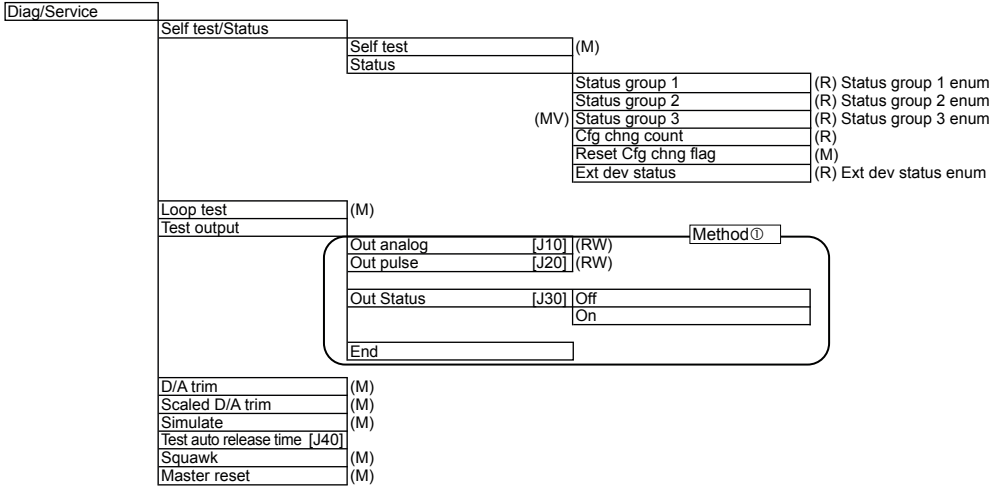

- | Status group 1 enum | Status group 2 enum | Status group 3 enum |
|-----------------------|----------------------------|---------------------|
| Flow over output | Transient noise | Temp over output |
| Span set error | High vibration | Over temp |
| Pulse out over | Clogging | Temp sensor fault |
| Pulse set error | Fluctuating | Temp convert fault |
| Device ID not entered | Burst configuration error | |
| Sensor fault | Device variable simulation | |
| Pre-amp fault | | |
| EEPROM fault | | |
-
- | Ext dev status enum |
|------------------------|
| Maintenace required |
| Device variable alert |
| Critical Power Failure |

F0911.ai

- (R) Read only
 - (CR) Continuous read
 - (RW) Read and Write
 - (M) Method of HCF
 - Unique Method of DY
 - (MV) Only for Multi-Variable Type
- [] Parameter No. in display and BRAIN Terminal.
 * Upload/Download

C (DD)

| | | | | | |
|-------------|--|--|--------------------|--------------------|------------|
| Basic setup | | Tag * | [C10] | (RW) | |
| | | Long Tag * | | (RW) | Method② |
| Easy setup | | Contact output | [B20] | Off | |
| | | Scaled pulse | | Pulse rate * | [B21] (RW) |
| | | Unscaled pulse | | ditto | |
| | | Frequency * | | Frequency at 100% | [B22] (RW) |
| | | Alarm | | | |
| | | Flow SW (Low : On) | | Setting level * | [B23] (RW) |
| | | Flow SW (Low : Off) | | ditto | |
| | | Display mode | Upper display * | [B30] | |
| | | | Lower display * | [B31] | |
| | | Totalizer | Total | | (CR) |
| | | | Total start/stop * | [B40] | |
| | | | Total rate * | [B45] | (RW) |
| | | | Total reset | [B47] | (M) |
| (MV) | | Analog out select * | [B50] | Flow | Method③ |
| | | Temp | | Temp unit | |
| | | | | Temp 0% | (RW) |
| | | | | Temp 100% | (RW) |
| | | | | Temp error out | |
| | | | | End | |
| Fluid * | | [C20] Liquid:Volume | | Volumetric unit * | [C22] |
| | | A message for thermometer type and "Saturated steam", "Superheat steam", "Gas: STD/Normal" or "Liquid: Mass" is selected Now *** setting mode of thermometer. Please set at another menu. Process abort. ***: A parameter selected in "Thermometer/Function" | | | |
| | | | | Time unit * | [C40] |
| | | | | End | |
| | | Gas/Steam:Volume | | ditto | |
| | | Liquid:Mass | | Density unit * | [C25] |
| | | | | Process density * | (RW) |
| | | | | Mass unit * | [C27] |
| | | | | Time unit * | [C40] (RW) |
| | | | | End | |
| | | Gas/Steam:Mas | | ditto | |
| | | Gas:STD/Normal | | Temp unit * | [C30] (RW) |
| | | | | Process temp * | [C31] (RW) |
| | | | | Base temp * | [C32] (RW) |
| | | | | Pressure unit * | [C33] |
| | | | | Process pressure * | [C34] (RW) |
| | | | | Base pressure * | [C35] (RW) |
| | | | | Deviation * | [C36] (RW) |
| | | | | STD/Normal unit * | [C37] |
| | | | | Time unit * | [C40] (RW) |
| | | | | End | |
| | | Flow span * | [C45] | (RW) | |
| | | Flow rate damping value | [C50] | (RW) | |

F0912.ai

(R) Read only [] Parameter No. in display and BRAIN Terminal.
 (CR) Continuous read
 (RW) Read and Write
 (M) Method of HCF
 [] Unique Method of DY
 (MV) Only for Multi-Variable Type

C (DTM)

| | |
|--------------------|---|
| Basic setup | |
| Tags | |
| | Tag (RW) |
| | Long tag (RW) |
| Easy setup | |
| | Contact output (M) Method ^② |
| | Display mode |
| | Upper display [B30] (RW) |
| | Lower display [B31] (RW) |
| | Totalizer |
| | Total [A30] (R) |
| | Total start/stop [B40] (RW) |
| | Total rate [B45] (RW) |
| | Total reset (M) |
| | Analog out select (M) Method ^③ |
| | Flow span [B10] (RW) |
| | Flow rate damping value [B15] (RW) |
| Device information | |
| | Date (RW) |
| | Descriptor (RW) |
| | Message (RW) |
| | Write protect (R) |
| | Model (R) |
| Others | |
| | Fluid (M) Method ^④ |

F0913.ai

(R) Read only
 (CR) Continuous read
 (RW) Read and Write
 (M) Method of HCF
 Unique Method of DY
 (MV) Only for Multi-Variable Type

[] Parameter No. in display and BRAIN Terminal.
 * Upload/Download

| | | |
|---------------------------|---|---|
| D | | |
| Detailed setup | | |
| Characterize meter | Nominal size * [E10] (RW) | |
| | Body type * [E20] (RW) | |
| | Sensor type * [E30] (RW) | |
| | K-factor setup | |
| | K-factor unit * [E40] (RW) | |
| | K-factor * [E41] (RW) | |
| | Detector No. * [E50] (RW) | |
| | Flow rate units | |
| | Fluid * [C20] (M): Method ④ | Method ⑤ |
| | Special unit [D40] No | |
| | Yes | Base unit * (R) User's unit * (RW) Conversion factor * (RW) End |
| | Special | Base unit * (R) User's unit * (RW) Conversion factor * (RW) End |
| Configure outputs | | |
| Analog outputs | Flow span * [B10] (RW) | |
| | Out limit(H) * [D30] (RW) | |
| | Burn out [D35] (R) | |
| | Loop current mode (RW) Loop current mode enum | |
| | Channel flags (R) | |
| Contact output * (M) | | |
| Display mode | Upper display [B30] (RW) | |
| | Lower display [B31] (RW) | |
| Totalizer | Total [A30] (CR) | |
| | Total start/stop [B40] (RW) | |
| | Total rate [B45] (RW) | |
| | Total reset [B47] (M) | |
| HART output | Poll addr (RW) | |
| | Loop current mode (RW) Loop current mode enum | |
| | Num req preams (R) | |
| | Num resp preams (RW) | |
| | Burst condition | |
| | Burst message 1 | Burst mode (RW) Burst mode enum Burst command (RW) Burst command enum Burst device variables (RW) Burst device variables enum Set Burst Trigger (M) Set Burst Period (M) Burst trigger mode (R) Burst trigger level (R) Update period (R) Update period enum Max update period (R) Update period enum |
| | Burst message 2 | ditto |
| | Burst message 3 | ditto |

To be continued to next page (D1)

Loop current mode enum

| |
|----------|
| Disabled |
| Enabled |

Burst mode enum

| |
|--------------------|
| Off |
| Wired HART Enabled |

Burst command enum

| |
|--|
| Cmd 1 : PV |
| Cmd 2 : % range/current |
| Cmd 3 : Dyn vars/current |
| Cmd 9 : Device vars w/ status |
| Cmd 33: Device variables |
| Cmd 46 : Read Additional Device Status |

Burst device variables enum

| |
|---------------------|
| Burst variable code |
| Burst variable code |
| Burst variable code |
| Burst variable code |
| Burst variable code |
| Burst variable code |
| Burst variable code |
| Burst variable code |

Update period enum

| |
|--------|
| 0.5 s |
| 1 s |
| 2 s |
| 4 s |
| 8 s |
| 16 s |
| 32 s |
| 1 min |
| 5 min |
| 10 min |
| 15 min |
| 30 min |
| 45 min |
| 60 min |

F0914.ai

- (R) Read only
 - (CR) Continuous read
 - (RW) Read and Write
 - (M) Method of HCF
 - Unique Method of DY
 - (MV) Only for Multi-Variable Type
- [] Parameter No. in display and BRAIN Terminal.
 - * Upload/Download

| | | | | | | | | | | | | | | | | | | | | | | | | | | | | | | | | | | | | | | | | | | | | | | | | | | | | | | | | | | | | | | | | | | | | | | | | | | | | | | | | | | | | | | | | | | | | | | | | | | | | | | | | | | | | | | | | | |
|--|--------------------------------------|--|----------------------------|--|------------|--|--------------------|--|----------------|--|----------------|--|----------------|--|---------------------|--|---------------------------------|--|-------------------------------|--|-------------------------------|--|-----------------|--|-------------------------|--|-----------|--|------------------------------|--|--------------------------|--|--------------------------------|--|----------------------------|--|-----------------------------|--|-------|--|-------|--|-------|--|-------|--|---------------------|--|---|--------------------|--|----------------|--------------------------|----------------|--------------------------|----------------|--------------------------|---------------------|--------------------------|---------------------------------|--------------------------------------|-------------------------------|--|-------------------------------|------------------------|-----------------|------------------------|-------------------------|-----|-----------|--|--------------------------------|-----|--------------|-----|--------------|-----|----------------------------------|-----|------------------------|-----|-----------------------|-----|----------------|-------------------------|----------------|-------------------------|----------------|-------------------------|------------------------|-------------------------|------------------------------------|-------------------------------------|------------------------------|--|--------------------------|-----|--------------------------------|-----|----------------------------|-----|-----------------------------|--|-------|--------------------|-------|-------------------------|-------|-------------------------|-------|-------------------------|---------------------|-------------------------|
| D1 | | | | | | | | | | | | | | | | | | | | | | | | | | | | | | | | | | | | | | | | | | | | | | | | | | | | | | | | | | | | | | | | | | | | | | | | | | | | | | | | | | | | | | | | | | | | | | | | | | | | | | | | | | | | | | | | | |
| <table border="1" style="width: 100%; border-collapse: collapse;"> <tr><td colspan="2">Event notification</td></tr> <tr><td colspan="2">Event notification control</td></tr> <tr><td colspan="2">Event mask</td></tr> <tr><td colspan="2">Device Status Mask</td></tr> <tr><td colspan="2">Status group 1</td></tr> <tr><td colspan="2">Status group 2</td></tr> <tr><td colspan="2">Status group 3</td></tr> <tr><td colspan="2">Ext dev status Mask</td></tr> <tr><td colspan="2">Device Diagnostic Status 0 Mask</td></tr> <tr><td colspan="2">Set event notification timing</td></tr> <tr><td colspan="2">Event notification retry time</td></tr> <tr><td colspan="2">Max update time</td></tr> <tr><td colspan="2">Event debounce interval</td></tr> <tr><td colspan="2">Knowledge</td></tr> <tr><td colspan="2">Flow rate Update time period</td></tr> <tr><td colspan="2">Total Update time period</td></tr> <tr><td colspan="2">Temperature Update time period</td></tr> <tr><td colspan="2">Density Update time period</td></tr> <tr><td colspan="2">Dynamic variable assignment</td></tr> <tr><td colspan="2">PV is</td></tr> <tr><td colspan="2">SV is</td></tr> <tr><td colspan="2">TV is</td></tr> <tr><td colspan="2">QV is</td></tr> <tr><td colspan="2">Chng dyn var assign</td></tr> </table> | Event notification | | Event notification control | | Event mask | | Device Status Mask | | Status group 1 | | Status group 2 | | Status group 3 | | Ext dev status Mask | | Device Diagnostic Status 0 Mask | | Set event notification timing | | Event notification retry time | | Max update time | | Event debounce interval | | Knowledge | | Flow rate Update time period | | Total Update time period | | Temperature Update time period | | Density Update time period | | Dynamic variable assignment | | PV is | | SV is | | TV is | | QV is | | Chng dyn var assign | | <table border="1" style="width: 100%; border-collapse: collapse;"> <tr><td colspan="2">Device Status Mask</td></tr> <tr><td>Status group 1</td><td>(RW) Status group 1 enum</td></tr> <tr><td>Status group 2</td><td>(RW) Status group 2 enum</td></tr> <tr><td>Status group 3</td><td>(RW) Status group 3 enum</td></tr> <tr><td>Ext dev status Mask</td><td>(RW) Ext dev status enum</td></tr> <tr><td>Device Diagnostic Status 0 Mask</td><td>(RW) Device Diagnostic Status 0 Mask</td></tr> <tr><td colspan="2">Set event notification timing</td></tr> <tr><td>Event notification retry time</td><td>(R) Update period enum</td></tr> <tr><td>Max update time</td><td>(R) Update period enum</td></tr> <tr><td>Event debounce interval</td><td>(R)</td></tr> <tr><td colspan="2">Knowledge</td></tr> <tr><td>Acknowledge event notification</td><td>(M)</td></tr> <tr><td>Event Status</td><td>(R)</td></tr> <tr><td>Event Number</td><td>(R)</td></tr> <tr><td>Time first unack event triggered</td><td>(R)</td></tr> <tr><td>Latched Cfg chng count</td><td>(R)</td></tr> <tr><td>Latched Device Status</td><td>(R)</td></tr> <tr><td>Status group 1</td><td>(R) Status group 1 enum</td></tr> <tr><td>Status group 2</td><td>(R) Status group 2 enum</td></tr> <tr><td>Status group 3</td><td>(R) Status group 3 enum</td></tr> <tr><td>Latched Ext dev status</td><td>(R) Ext dev status enum</td></tr> <tr><td>Latched Device Diagnostic Status S</td><td>(R) Device Diagnostic Status 0 Mask</td></tr> <tr><td colspan="2">Flow rate Update time period</td></tr> <tr><td>Total Update time period</td><td>(R)</td></tr> <tr><td>Temperature Update time period</td><td>(R)</td></tr> <tr><td>Density Update time period</td><td>(R)</td></tr> <tr><td colspan="2">Dynamic variable assignment</td></tr> <tr><td>PV is</td><td>(R) PV assign enum</td></tr> <tr><td>SV is</td><td>(R) Dyn var assign enum</td></tr> <tr><td>TV is</td><td>(R) Dyn var assign enum</td></tr> <tr><td>QV is</td><td>(R) Dyn var assign enum</td></tr> <tr><td>Chng dyn var assign</td><td>(M) Dyn var assign enum</td></tr> </table> | Device Status Mask | | Status group 1 | (RW) Status group 1 enum | Status group 2 | (RW) Status group 2 enum | Status group 3 | (RW) Status group 3 enum | Ext dev status Mask | (RW) Ext dev status enum | Device Diagnostic Status 0 Mask | (RW) Device Diagnostic Status 0 Mask | Set event notification timing | | Event notification retry time | (R) Update period enum | Max update time | (R) Update period enum | Event debounce interval | (R) | Knowledge | | Acknowledge event notification | (M) | Event Status | (R) | Event Number | (R) | Time first unack event triggered | (R) | Latched Cfg chng count | (R) | Latched Device Status | (R) | Status group 1 | (R) Status group 1 enum | Status group 2 | (R) Status group 2 enum | Status group 3 | (R) Status group 3 enum | Latched Ext dev status | (R) Ext dev status enum | Latched Device Diagnostic Status S | (R) Device Diagnostic Status 0 Mask | Flow rate Update time period | | Total Update time period | (R) | Temperature Update time period | (R) | Density Update time period | (R) | Dynamic variable assignment | | PV is | (R) PV assign enum | SV is | (R) Dyn var assign enum | TV is | (R) Dyn var assign enum | QV is | (R) Dyn var assign enum | Chng dyn var assign | (M) Dyn var assign enum |
| Event notification | | | | | | | | | | | | | | | | | | | | | | | | | | | | | | | | | | | | | | | | | | | | | | | | | | | | | | | | | | | | | | | | | | | | | | | | | | | | | | | | | | | | | | | | | | | | | | | | | | | | | | | | | | | | | | | | | |
| Event notification control | | | | | | | | | | | | | | | | | | | | | | | | | | | | | | | | | | | | | | | | | | | | | | | | | | | | | | | | | | | | | | | | | | | | | | | | | | | | | | | | | | | | | | | | | | | | | | | | | | | | | | | | | | | | | | | | | |
| Event mask | | | | | | | | | | | | | | | | | | | | | | | | | | | | | | | | | | | | | | | | | | | | | | | | | | | | | | | | | | | | | | | | | | | | | | | | | | | | | | | | | | | | | | | | | | | | | | | | | | | | | | | | | | | | | | | | | |
| Device Status Mask | | | | | | | | | | | | | | | | | | | | | | | | | | | | | | | | | | | | | | | | | | | | | | | | | | | | | | | | | | | | | | | | | | | | | | | | | | | | | | | | | | | | | | | | | | | | | | | | | | | | | | | | | | | | | | | | | |
| Status group 1 | | | | | | | | | | | | | | | | | | | | | | | | | | | | | | | | | | | | | | | | | | | | | | | | | | | | | | | | | | | | | | | | | | | | | | | | | | | | | | | | | | | | | | | | | | | | | | | | | | | | | | | | | | | | | | | | | |
| Status group 2 | | | | | | | | | | | | | | | | | | | | | | | | | | | | | | | | | | | | | | | | | | | | | | | | | | | | | | | | | | | | | | | | | | | | | | | | | | | | | | | | | | | | | | | | | | | | | | | | | | | | | | | | | | | | | | | | | |
| Status group 3 | | | | | | | | | | | | | | | | | | | | | | | | | | | | | | | | | | | | | | | | | | | | | | | | | | | | | | | | | | | | | | | | | | | | | | | | | | | | | | | | | | | | | | | | | | | | | | | | | | | | | | | | | | | | | | | | | |
| Ext dev status Mask | | | | | | | | | | | | | | | | | | | | | | | | | | | | | | | | | | | | | | | | | | | | | | | | | | | | | | | | | | | | | | | | | | | | | | | | | | | | | | | | | | | | | | | | | | | | | | | | | | | | | | | | | | | | | | | | | |
| Device Diagnostic Status 0 Mask | | | | | | | | | | | | | | | | | | | | | | | | | | | | | | | | | | | | | | | | | | | | | | | | | | | | | | | | | | | | | | | | | | | | | | | | | | | | | | | | | | | | | | | | | | | | | | | | | | | | | | | | | | | | | | | | | |
| Set event notification timing | | | | | | | | | | | | | | | | | | | | | | | | | | | | | | | | | | | | | | | | | | | | | | | | | | | | | | | | | | | | | | | | | | | | | | | | | | | | | | | | | | | | | | | | | | | | | | | | | | | | | | | | | | | | | | | | | |
| Event notification retry time | | | | | | | | | | | | | | | | | | | | | | | | | | | | | | | | | | | | | | | | | | | | | | | | | | | | | | | | | | | | | | | | | | | | | | | | | | | | | | | | | | | | | | | | | | | | | | | | | | | | | | | | | | | | | | | | | |
| Max update time | | | | | | | | | | | | | | | | | | | | | | | | | | | | | | | | | | | | | | | | | | | | | | | | | | | | | | | | | | | | | | | | | | | | | | | | | | | | | | | | | | | | | | | | | | | | | | | | | | | | | | | | | | | | | | | | | |
| Event debounce interval | | | | | | | | | | | | | | | | | | | | | | | | | | | | | | | | | | | | | | | | | | | | | | | | | | | | | | | | | | | | | | | | | | | | | | | | | | | | | | | | | | | | | | | | | | | | | | | | | | | | | | | | | | | | | | | | | |
| Knowledge | | | | | | | | | | | | | | | | | | | | | | | | | | | | | | | | | | | | | | | | | | | | | | | | | | | | | | | | | | | | | | | | | | | | | | | | | | | | | | | | | | | | | | | | | | | | | | | | | | | | | | | | | | | | | | | | | |
| Flow rate Update time period | | | | | | | | | | | | | | | | | | | | | | | | | | | | | | | | | | | | | | | | | | | | | | | | | | | | | | | | | | | | | | | | | | | | | | | | | | | | | | | | | | | | | | | | | | | | | | | | | | | | | | | | | | | | | | | | | |
| Total Update time period | | | | | | | | | | | | | | | | | | | | | | | | | | | | | | | | | | | | | | | | | | | | | | | | | | | | | | | | | | | | | | | | | | | | | | | | | | | | | | | | | | | | | | | | | | | | | | | | | | | | | | | | | | | | | | | | | |
| Temperature Update time period | | | | | | | | | | | | | | | | | | | | | | | | | | | | | | | | | | | | | | | | | | | | | | | | | | | | | | | | | | | | | | | | | | | | | | | | | | | | | | | | | | | | | | | | | | | | | | | | | | | | | | | | | | | | | | | | | |
| Density Update time period | | | | | | | | | | | | | | | | | | | | | | | | | | | | | | | | | | | | | | | | | | | | | | | | | | | | | | | | | | | | | | | | | | | | | | | | | | | | | | | | | | | | | | | | | | | | | | | | | | | | | | | | | | | | | | | | | |
| Dynamic variable assignment | | | | | | | | | | | | | | | | | | | | | | | | | | | | | | | | | | | | | | | | | | | | | | | | | | | | | | | | | | | | | | | | | | | | | | | | | | | | | | | | | | | | | | | | | | | | | | | | | | | | | | | | | | | | | | | | | |
| PV is | | | | | | | | | | | | | | | | | | | | | | | | | | | | | | | | | | | | | | | | | | | | | | | | | | | | | | | | | | | | | | | | | | | | | | | | | | | | | | | | | | | | | | | | | | | | | | | | | | | | | | | | | | | | | | | | | |
| SV is | | | | | | | | | | | | | | | | | | | | | | | | | | | | | | | | | | | | | | | | | | | | | | | | | | | | | | | | | | | | | | | | | | | | | | | | | | | | | | | | | | | | | | | | | | | | | | | | | | | | | | | | | | | | | | | | | |
| TV is | | | | | | | | | | | | | | | | | | | | | | | | | | | | | | | | | | | | | | | | | | | | | | | | | | | | | | | | | | | | | | | | | | | | | | | | | | | | | | | | | | | | | | | | | | | | | | | | | | | | | | | | | | | | | | | | | |
| QV is | | | | | | | | | | | | | | | | | | | | | | | | | | | | | | | | | | | | | | | | | | | | | | | | | | | | | | | | | | | | | | | | | | | | | | | | | | | | | | | | | | | | | | | | | | | | | | | | | | | | | | | | | | | | | | | | | |
| Chng dyn var assign | | | | | | | | | | | | | | | | | | | | | | | | | | | | | | | | | | | | | | | | | | | | | | | | | | | | | | | | | | | | | | | | | | | | | | | | | | | | | | | | | | | | | | | | | | | | | | | | | | | | | | | | | | | | | | | | | |
| Device Status Mask | | | | | | | | | | | | | | | | | | | | | | | | | | | | | | | | | | | | | | | | | | | | | | | | | | | | | | | | | | | | | | | | | | | | | | | | | | | | | | | | | | | | | | | | | | | | | | | | | | | | | | | | | | | | | | | | | |
| Status group 1 | (RW) Status group 1 enum | | | | | | | | | | | | | | | | | | | | | | | | | | | | | | | | | | | | | | | | | | | | | | | | | | | | | | | | | | | | | | | | | | | | | | | | | | | | | | | | | | | | | | | | | | | | | | | | | | | | | | | | | | | | | | | | |
| Status group 2 | (RW) Status group 2 enum | | | | | | | | | | | | | | | | | | | | | | | | | | | | | | | | | | | | | | | | | | | | | | | | | | | | | | | | | | | | | | | | | | | | | | | | | | | | | | | | | | | | | | | | | | | | | | | | | | | | | | | | | | | | | | | | |
| Status group 3 | (RW) Status group 3 enum | | | | | | | | | | | | | | | | | | | | | | | | | | | | | | | | | | | | | | | | | | | | | | | | | | | | | | | | | | | | | | | | | | | | | | | | | | | | | | | | | | | | | | | | | | | | | | | | | | | | | | | | | | | | | | | | |
| Ext dev status Mask | (RW) Ext dev status enum | | | | | | | | | | | | | | | | | | | | | | | | | | | | | | | | | | | | | | | | | | | | | | | | | | | | | | | | | | | | | | | | | | | | | | | | | | | | | | | | | | | | | | | | | | | | | | | | | | | | | | | | | | | | | | | | |
| Device Diagnostic Status 0 Mask | (RW) Device Diagnostic Status 0 Mask | | | | | | | | | | | | | | | | | | | | | | | | | | | | | | | | | | | | | | | | | | | | | | | | | | | | | | | | | | | | | | | | | | | | | | | | | | | | | | | | | | | | | | | | | | | | | | | | | | | | | | | | | | | | | | | | |
| Set event notification timing | | | | | | | | | | | | | | | | | | | | | | | | | | | | | | | | | | | | | | | | | | | | | | | | | | | | | | | | | | | | | | | | | | | | | | | | | | | | | | | | | | | | | | | | | | | | | | | | | | | | | | | | | | | | | | | | | |
| Event notification retry time | (R) Update period enum | | | | | | | | | | | | | | | | | | | | | | | | | | | | | | | | | | | | | | | | | | | | | | | | | | | | | | | | | | | | | | | | | | | | | | | | | | | | | | | | | | | | | | | | | | | | | | | | | | | | | | | | | | | | | | | | |
| Max update time | (R) Update period enum | | | | | | | | | | | | | | | | | | | | | | | | | | | | | | | | | | | | | | | | | | | | | | | | | | | | | | | | | | | | | | | | | | | | | | | | | | | | | | | | | | | | | | | | | | | | | | | | | | | | | | | | | | | | | | | | |
| Event debounce interval | (R) | | | | | | | | | | | | | | | | | | | | | | | | | | | | | | | | | | | | | | | | | | | | | | | | | | | | | | | | | | | | | | | | | | | | | | | | | | | | | | | | | | | | | | | | | | | | | | | | | | | | | | | | | | | | | | | | |
| Knowledge | | | | | | | | | | | | | | | | | | | | | | | | | | | | | | | | | | | | | | | | | | | | | | | | | | | | | | | | | | | | | | | | | | | | | | | | | | | | | | | | | | | | | | | | | | | | | | | | | | | | | | | | | | | | | | | | | |
| Acknowledge event notification | (M) | | | | | | | | | | | | | | | | | | | | | | | | | | | | | | | | | | | | | | | | | | | | | | | | | | | | | | | | | | | | | | | | | | | | | | | | | | | | | | | | | | | | | | | | | | | | | | | | | | | | | | | | | | | | | | | | |
| Event Status | (R) | | | | | | | | | | | | | | | | | | | | | | | | | | | | | | | | | | | | | | | | | | | | | | | | | | | | | | | | | | | | | | | | | | | | | | | | | | | | | | | | | | | | | | | | | | | | | | | | | | | | | | | | | | | | | | | | |
| Event Number | (R) | | | | | | | | | | | | | | | | | | | | | | | | | | | | | | | | | | | | | | | | | | | | | | | | | | | | | | | | | | | | | | | | | | | | | | | | | | | | | | | | | | | | | | | | | | | | | | | | | | | | | | | | | | | | | | | | |
| Time first unack event triggered | (R) | | | | | | | | | | | | | | | | | | | | | | | | | | | | | | | | | | | | | | | | | | | | | | | | | | | | | | | | | | | | | | | | | | | | | | | | | | | | | | | | | | | | | | | | | | | | | | | | | | | | | | | | | | | | | | | | |
| Latched Cfg chng count | (R) | | | | | | | | | | | | | | | | | | | | | | | | | | | | | | | | | | | | | | | | | | | | | | | | | | | | | | | | | | | | | | | | | | | | | | | | | | | | | | | | | | | | | | | | | | | | | | | | | | | | | | | | | | | | | | | | |
| Latched Device Status | (R) | | | | | | | | | | | | | | | | | | | | | | | | | | | | | | | | | | | | | | | | | | | | | | | | | | | | | | | | | | | | | | | | | | | | | | | | | | | | | | | | | | | | | | | | | | | | | | | | | | | | | | | | | | | | | | | | |
| Status group 1 | (R) Status group 1 enum | | | | | | | | | | | | | | | | | | | | | | | | | | | | | | | | | | | | | | | | | | | | | | | | | | | | | | | | | | | | | | | | | | | | | | | | | | | | | | | | | | | | | | | | | | | | | | | | | | | | | | | | | | | | | | | | |
| Status group 2 | (R) Status group 2 enum | | | | | | | | | | | | | | | | | | | | | | | | | | | | | | | | | | | | | | | | | | | | | | | | | | | | | | | | | | | | | | | | | | | | | | | | | | | | | | | | | | | | | | | | | | | | | | | | | | | | | | | | | | | | | | | | |
| Status group 3 | (R) Status group 3 enum | | | | | | | | | | | | | | | | | | | | | | | | | | | | | | | | | | | | | | | | | | | | | | | | | | | | | | | | | | | | | | | | | | | | | | | | | | | | | | | | | | | | | | | | | | | | | | | | | | | | | | | | | | | | | | | | |
| Latched Ext dev status | (R) Ext dev status enum | | | | | | | | | | | | | | | | | | | | | | | | | | | | | | | | | | | | | | | | | | | | | | | | | | | | | | | | | | | | | | | | | | | | | | | | | | | | | | | | | | | | | | | | | | | | | | | | | | | | | | | | | | | | | | | | |
| Latched Device Diagnostic Status S | (R) Device Diagnostic Status 0 Mask | | | | | | | | | | | | | | | | | | | | | | | | | | | | | | | | | | | | | | | | | | | | | | | | | | | | | | | | | | | | | | | | | | | | | | | | | | | | | | | | | | | | | | | | | | | | | | | | | | | | | | | | | | | | | | | | |
| Flow rate Update time period | | | | | | | | | | | | | | | | | | | | | | | | | | | | | | | | | | | | | | | | | | | | | | | | | | | | | | | | | | | | | | | | | | | | | | | | | | | | | | | | | | | | | | | | | | | | | | | | | | | | | | | | | | | | | | | | | |
| Total Update time period | (R) | | | | | | | | | | | | | | | | | | | | | | | | | | | | | | | | | | | | | | | | | | | | | | | | | | | | | | | | | | | | | | | | | | | | | | | | | | | | | | | | | | | | | | | | | | | | | | | | | | | | | | | | | | | | | | | | |
| Temperature Update time period | (R) | | | | | | | | | | | | | | | | | | | | | | | | | | | | | | | | | | | | | | | | | | | | | | | | | | | | | | | | | | | | | | | | | | | | | | | | | | | | | | | | | | | | | | | | | | | | | | | | | | | | | | | | | | | | | | | | |
| Density Update time period | (R) | | | | | | | | | | | | | | | | | | | | | | | | | | | | | | | | | | | | | | | | | | | | | | | | | | | | | | | | | | | | | | | | | | | | | | | | | | | | | | | | | | | | | | | | | | | | | | | | | | | | | | | | | | | | | | | | |
| Dynamic variable assignment | | | | | | | | | | | | | | | | | | | | | | | | | | | | | | | | | | | | | | | | | | | | | | | | | | | | | | | | | | | | | | | | | | | | | | | | | | | | | | | | | | | | | | | | | | | | | | | | | | | | | | | | | | | | | | | | | |
| PV is | (R) PV assign enum | | | | | | | | | | | | | | | | | | | | | | | | | | | | | | | | | | | | | | | | | | | | | | | | | | | | | | | | | | | | | | | | | | | | | | | | | | | | | | | | | | | | | | | | | | | | | | | | | | | | | | | | | | | | | | | | |
| SV is | (R) Dyn var assign enum | | | | | | | | | | | | | | | | | | | | | | | | | | | | | | | | | | | | | | | | | | | | | | | | | | | | | | | | | | | | | | | | | | | | | | | | | | | | | | | | | | | | | | | | | | | | | | | | | | | | | | | | | | | | | | | | |
| TV is | (R) Dyn var assign enum | | | | | | | | | | | | | | | | | | | | | | | | | | | | | | | | | | | | | | | | | | | | | | | | | | | | | | | | | | | | | | | | | | | | | | | | | | | | | | | | | | | | | | | | | | | | | | | | | | | | | | | | | | | | | | | | |
| QV is | (R) Dyn var assign enum | | | | | | | | | | | | | | | | | | | | | | | | | | | | | | | | | | | | | | | | | | | | | | | | | | | | | | | | | | | | | | | | | | | | | | | | | | | | | | | | | | | | | | | | | | | | | | | | | | | | | | | | | | | | | | | | |
| Chng dyn var assign | (M) Dyn var assign enum | | | | | | | | | | | | | | | | | | | | | | | | | | | | | | | | | | | | | | | | | | | | | | | | | | | | | | | | | | | | | | | | | | | | | | | | | | | | | | | | | | | | | | | | | | | | | | | | | | | | | | | | | | | | | | | | |

To be continued to next page (D2)

| |
|---------------------------------------|
| Device Diagnostic Status 0 Mask |
| Simulation active |
| Non-Volatile memory failure |
| Volatile memory error |
| Watchdog reset executed |
| Voltage conditions out of range |
| Environmental conditions out of range |
| Electronic failure |

| |
|----------------|
| PV assign enum |
| Flow rate |
| Temperature |

| |
|---------------------|
| Dyn var assign enum |
| Flow rate |
| Total |
| Temperature |
| Density |

F0915.ai

(R) Read only [] Parameter No. in display and BRAIN Terminal.
 (CR) Continuous read * Upload/Download
 (RW) Read and Write
 (M) Method of HCF
 Unique Method of DY
 (MV) Only for Multi-Variable Type

D2

| | |
|---|------------------------------|
| Signal processing | |
| Flow rate damping value [B15] | (RW) |
| Low cut * [D10] | (RW) |
| Temp setup | |
| Temp unit [D20] | (RW) |
| Process temp [D21] | (RW) |
| Density setup | |
| Density unit [D25] | (RW) |
| Process density [D26] | (RW) |
| Maintenance | |
| TLA * [K10] | (RW) |
| Signal level * [K20] | (RW) |
| Noise balance mode * [K25] Auto (RW) Method⑥ | |
| | Manual Set noise ratio (RW) |
| | End |
| | Tuning at zero flow |
| Noise ratio * [K26] | (CR) |
| Maintenance data | |
| Velocity [K30] | (CR) |
| Span velocity [K32] | (CR) |
| Vortex frequency [K34] | (CR) |
| Span frequency [K36] | (CR) |
| (MV) Density [K38] | (CR) |
| Error record [K40] | |
| Err record reset | (M) |
| Er record status 1 | (CR) Er record status 1 enum |
| Er record status 2 | (CR) Er record status 2 enum |
| (MV) Er record status 3 | (CR) Status group 3 enum |
| High vibration * [K45] | (RW) |
| Amplifier check Set vortex frequency [K28] (RW) Method⑦ | |
| | End |
| Menu type number | (RW) |
| Menu type | (R) |
| Adjust | |
| User adjust * [H20] | (RW) Method⑧ |
| Reynolds adjust * [H25] Not active | |
| | Active Process density (RW) |
| | Viscosity * (RW) |
| | End |
| Gas expansion fact * [H30] | |
| | Not active (RW) |
| | Active (RW) |
| Flow adjust * [H40] Not active Method⑨ | |
| | Active |
| | Set point 1-data * (RW) |
| | Set point 2-data * (RW) |
| | Set point 3-data * (RW) |
| | Set point 4-data * (RW) |
| | Set point 5-data * (RW) |
| | End |

To be continued to next page (D3)

Er record status 1 enum

| |
|------------------|
| Flow over output |
| Span set error |
| Pulse out over |
| Pulse set error |
| Sensor fault |
| Pre-amp fault |
| EEPROM fault |

Er record status 2 enum

| |
|-----------------|
| Transient noise |
| High vibraton |
| Clogging |
| Fluctuating |

F0916.ai

- (R) Read only
 - (CR) Continuous read
 - (RW) Read and Write
 - (M) Method of HCF
 - Unique Method of DY
 - (MV) Only for Multi-Variable Type
- [] Parameter No. in display and BRAIN Terminal.
 * Upload/Download

| D3 | | | | | | | | | | | | | | | | | | | | | | | | | | | | |
|------------------------------|---|-------------------------|-------|-------------------------|------------------|-------|------|---------------|-------|-------------------------|------------------|-------|------|-------------------|-------|------|-------------------|-------|------|-----------------|-------|------|-----------|-------|------|-----|--|--|
| Device information | | | | | | | | | | | | | | | | | | | | | | | | | | | | |
| Manufacturer | (R) | | | | | | | | | | | | | | | | | | | | | | | | | | | |
| Tag * | (RW) | | | | | | | | | | | | | | | | | | | | | | | | | | | |
| Long tag * | (RW) | | | | | | | | | | | | | | | | | | | | | | | | | | | |
| Descriptor * | (RW) | | | | | | | | | | | | | | | | | | | | | | | | | | | |
| Message * | (RW) | | | | | | | | | | | | | | | | | | | | | | | | | | | |
| Date * | (RW) | | | | | | | | | | | | | | | | | | | | | | | | | | | |
| Write protect | (R) | | | | | | | | | | | | | | | | | | | | | | | | | | | |
| Revision numbers | | | | | | | | | | | | | | | | | | | | | | | | | | | | |
| Universal rev | (R) | | | | | | | | | | | | | | | | | | | | | | | | | | | |
| Fld dev rev | (R) | | | | | | | | | | | | | | | | | | | | | | | | | | | |
| Software rev | (R) | | | | | | | | | | | | | | | | | | | | | | | | | | | |
| Hardware rev | (R) | | | | | | | | | | | | | | | | | | | | | | | | | | | |
| Final asmbly num | (R) | | | | | | | | | | | | | | | | | | | | | | | | | | | |
| Dev id | (R) | | | | | | | | | | | | | | | | | | | | | | | | | | | |
| Next universal rev | (R) | | | | | | | | | | | | | | | | | | | | | | | | | | | |
| Chng universal rev | (M) | | | | | | | | | | | | | | | | | | | | | | | | | | | |
| Max dev vars | (R) | | | | | | | | | | | | | | | | | | | | | | | | | | | |
| Device profile | (R) Device profile enum | | | | | | | | | | | | | | | | | | | | | | | | | | | |
| Flow rate Update time period | (R) | | | | | | | | | | | | | | | | | | | | | | | | | | | |
| Country | (RW) Country enum | | | | | | | | | | | | | | | | | | | | | | | | | | | |
| (MV) Thermometer | | | | | | | | | | | | | | | | | | | | | | | | | | | | |
| Function | | | | | | | | | | | | | | | | | | | | | | | | | | | | |
| Monitor only | Method® | | | | | | | | | | | | | | | | | | | | | | | | | | | |
| Saturated steam | <table border="1"> <tr> <td>Mass unit</td> <td>[F12]</td> <td>(RW)</td> </tr> <tr> <td>Time unit</td> <td>[F35]</td> <td>(RW)</td> </tr> <tr> <td>End</td> <td></td> <td></td> </tr> </table> | Mass unit | [F12] | (RW) | Time unit | [F35] | (RW) | End | | | | | | | | | | | | | | | | | | | | |
| Mass unit | [F12] | (RW) | | | | | | | | | | | | | | | | | | | | | | | | | | |
| Time unit | [F35] | (RW) | | | | | | | | | | | | | | | | | | | | | | | | | | |
| End | | | | | | | | | | | | | | | | | | | | | | | | | | | | |
| Superheat steam | <table border="1"> <tr> <td>Pressure unit</td> <td>[F14]</td> <td>(RW) Pressure unit enum</td> </tr> <tr> <td>Process pressure</td> <td>[F15]</td> <td>(RW)</td> </tr> <tr> <td>Mass unit</td> <td>[F16]</td> <td>(RW)</td> </tr> <tr> <td>Time unit</td> <td>[F35]</td> <td>(RW)</td> </tr> <tr> <td>End</td> <td></td> <td></td> </tr> </table> | Pressure unit | [F14] | (RW) Pressure unit enum | Process pressure | [F15] | (RW) | Mass unit | [F16] | (RW) | Time unit | [F35] | (RW) | End | | | | | | | | | | | | | | |
| Pressure unit | [F14] | (RW) Pressure unit enum | | | | | | | | | | | | | | | | | | | | | | | | | | |
| Process pressure | [F15] | (RW) | | | | | | | | | | | | | | | | | | | | | | | | | | |
| Mass unit | [F16] | (RW) | | | | | | | | | | | | | | | | | | | | | | | | | | |
| Time unit | [F35] | (RW) | | | | | | | | | | | | | | | | | | | | | | | | | | |
| End | | | | | | | | | | | | | | | | | | | | | | | | | | | | |
| Gas:STD/Normal | <table border="1"> <tr> <td>Temp unit</td> <td>[F18]</td> <td>(RW)</td> </tr> <tr> <td>Base temp</td> <td>[F19]</td> <td>(RW)</td> </tr> <tr> <td>Pressure unit</td> <td>[F20]</td> <td>(RW) Pressure unit enum</td> </tr> <tr> <td>Process pressure</td> <td>[F21]</td> <td>(RW)</td> </tr> <tr> <td>Base pressure</td> <td>[F22]</td> <td>(RW)</td> </tr> <tr> <td>Deviation</td> <td>[F23]</td> <td>(RW)</td> </tr> <tr> <td>STD/Normal unit</td> <td>[F24]</td> <td>(RW)</td> </tr> <tr> <td>Time unit</td> <td>[F35]</td> <td>(RW)</td> </tr> <tr> <td>End</td> <td></td> <td></td> </tr> </table> | Temp unit | [F18] | (RW) | Base temp | [F19] | (RW) | Pressure unit | [F20] | (RW) Pressure unit enum | Process pressure | [F21] | (RW) | Base pressure | [F22] | (RW) | Deviation | [F23] | (RW) | STD/Normal unit | [F24] | (RW) | Time unit | [F35] | (RW) | End | | |
| Temp unit | [F18] | (RW) | | | | | | | | | | | | | | | | | | | | | | | | | | |
| Base temp | [F19] | (RW) | | | | | | | | | | | | | | | | | | | | | | | | | | |
| Pressure unit | [F20] | (RW) Pressure unit enum | | | | | | | | | | | | | | | | | | | | | | | | | | |
| Process pressure | [F21] | (RW) | | | | | | | | | | | | | | | | | | | | | | | | | | |
| Base pressure | [F22] | (RW) | | | | | | | | | | | | | | | | | | | | | | | | | | |
| Deviation | [F23] | (RW) | | | | | | | | | | | | | | | | | | | | | | | | | | |
| STD/Normal unit | [F24] | (RW) | | | | | | | | | | | | | | | | | | | | | | | | | | |
| Time unit | [F35] | (RW) | | | | | | | | | | | | | | | | | | | | | | | | | | |
| End | | | | | | | | | | | | | | | | | | | | | | | | | | | | |
| Liquid:Mass | <table border="1"> <tr> <td>Density unit</td> <td>[F26]</td> <td>(RW)</td> </tr> <tr> <td>Base density *</td> <td>[F27]</td> <td>(RW)</td> </tr> <tr> <td>Temp unit</td> <td>[F28]</td> <td>(RW)</td> </tr> <tr> <td>Base temp</td> <td>[F29]</td> <td>(RW)</td> </tr> <tr> <td>1'st temp coeff *</td> <td>[F30]</td> <td>(RW)</td> </tr> <tr> <td>2'nd temp coeff *</td> <td>[F31]</td> <td>(RW)</td> </tr> <tr> <td>Mass unit</td> <td>[F32]</td> <td>(RW)</td> </tr> <tr> <td>Time unit</td> <td>[F35]</td> <td>(RW)</td> </tr> <tr> <td>End</td> <td></td> <td></td> </tr> </table> | Density unit | [F26] | (RW) | Base density * | [F27] | (RW) | Temp unit | [F28] | (RW) | Base temp | [F29] | (RW) | 1'st temp coeff * | [F30] | (RW) | 2'nd temp coeff * | [F31] | (RW) | Mass unit | [F32] | (RW) | Time unit | [F35] | (RW) | End | | |
| Density unit | [F26] | (RW) | | | | | | | | | | | | | | | | | | | | | | | | | | |
| Base density * | [F27] | (RW) | | | | | | | | | | | | | | | | | | | | | | | | | | |
| Temp unit | [F28] | (RW) | | | | | | | | | | | | | | | | | | | | | | | | | | |
| Base temp | [F29] | (RW) | | | | | | | | | | | | | | | | | | | | | | | | | | |
| 1'st temp coeff * | [F30] | (RW) | | | | | | | | | | | | | | | | | | | | | | | | | | |
| 2'nd temp coeff * | [F31] | (RW) | | | | | | | | | | | | | | | | | | | | | | | | | | |
| Mass unit | [F32] | (RW) | | | | | | | | | | | | | | | | | | | | | | | | | | |
| Time unit | [F35] | (RW) | | | | | | | | | | | | | | | | | | | | | | | | | | |
| End | | | | | | | | | | | | | | | | | | | | | | | | | | | | |
| Not use | | | | | | | | | | | | | | | | | | | | | | | | | | | | |
| Cable length * | [F52] (RW) | | | | | | | | | | | | | | | | | | | | | | | | | | | |
| Temp damping * | [F50] (RW) | | | | | | | | | | | | | | | | | | | | | | | | | | | |
| Analog out select * | [F55] (M): Method® | | | | | | | | | | | | | | | | | | | | | | | | | | | |

| E | |
|---------------|--|
| Review | |
| Review 1 | |
| Review 2 | |
| Review 3 | |
| (MV) Review 4 | |

| Device profile enum | |
|---------------------------|--|
| Process automation device | |
| Discrete device | |

| Country enum | |
|--------------|--|
| 0x5553 "US" | |
| 0x4a50 "JP" | |
| 0x4445 "DE" | |
| 0x4652 "FR" | |
| 0x4553 "ES" | |
| 0x5255 "RU" | |
| 0x434e "CN" | |

| Pressure unit enum | |
|--------------------|--|
| MPa abs | |
| kPa abs | |
| kg/Sqcm abs | |
| bar abs | |
| psia | |

F0917.ai

| Review 1 | Review 2 | Review 3 | Review 4 |
|-------------------|-------------------------|--------------------|-------------------|
| Model | Flow rate unit | Special unit | Function |
| Manufacturer | Flow span | User's unit | Base density |
| Distributor | Flow rate damping value | Conversion factor | 1'st temp coeff |
| Cfg chng count | Contact output | Nominal size | 2'nd temp coeff |
| Max dev vars | Pulse rate | Body type | Cable length |
| Tag | Frequency at 100% | Sensor type | Temp damping |
| Long tag | Setting level | K-factor | Analog out select |
| Descriptor | Upper display | Detector No | Temp 0% |
| Message | Lower display | User adjust | Temp 100% |
| Date | Total rate | Reynolds adjust | Temp error out |
| Dev id | Total start/stop | Viscosity | (Only for /MV) |
| Write protect | Fluid | Gas expansion fact | |
| AO Alm typ | Process density | Flow adjust | |
| Universal rev | Process temp | TLA | |
| FId dev rev | Base temp | Signal level | |
| Software rev | Process pressure | Noise balance mode | |
| Hardware rev | Base pressure | Noise ratio | |
| Poll addr | Deviation | High vib. | |
| Loop current mode | Low cut | Span velocity | |
| Num req preams | Out limit (H) | Span frequency | |
| Num resp preams | Burn out | | |

F0918.ai

10. OPERATION

After you have installed the flowmeter into the process piping, wired the input/output terminals, set up the required parameters, the vortex flowmeter should output an accurate flow signal from its terminals as soon as the measured liquid begins to flow.

This section describes procedure of test method and adjustment method for the pre-operation.



NOTE

The initial parameter setting has already been done at the factory according to the sizing data when ordering. Therefore it is not necessary to set parameters except measurement condition changes or some additions happen.

10.1 Adjustment

10.1.1 Zero Adjustment

No zero adjustment is necessary since the zero point does not shift.

Because of the effect of electrical noise and vibration noise, digitalYEWFL0 may provide an output even when the flowrate is zero. In that case, properly eliminate the source of the noise.

Read Section 10.2 “Adjustment for Manual Mode.”

10.1.2 Span Adjustment

In normal application, you need not confirm the span.

If you need to ensure the output of 4 to 20mA DC, read Subsection 10.1.3 “Loop Test.”

10.1.3 Loop Test

To ensure output of 4 to 20mA DC or pulse, their loop tests can be done using parameter “J10 (Analog out)” or “J20 (Pulse test)”.

If you are verifying the analog output, follow the procedure on the verification procedure.

<Check Procedure>

1. Connect the instruments by reading Figure 10.1, and warm up for three minutes more.
2. Set span frequency in Parameter J10:OUT ANALOG.

3. In case the load resistance is 250Ω, digital multimeter indicates 5V. Otherwise if it is known load resistance value, it indicates $R (\Omega) \times 0.02$ (A).
4. Check output value is in the rated value (± 0.016 mA) after set 50% in Parameter J10.
5. Check output value is in the rated value (± 0.016 mA) after set 0% in Parameter J10.

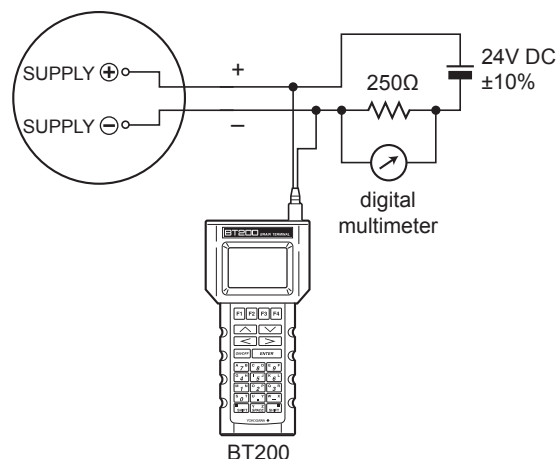

Figure 10.1 Connection of Maintenance Instruments



IMPORTANT

- When using any test-purpose measuring instruments, do not ground them.
- All of your parameter settings will be cancelled if you turn digitalYEWFL0 off less than 30 seconds after the parameter setup. Keep digitalYEWFL0 turned on at least 30 seconds after setting up the parameters.



NOTE

When configure the parameters using the HART Configuration Tool, read Section 8.11 “Menu Tree (HART 5)” or Section 9.11 “Menu Tree (HART 7).”

10.1.4 Totalizer Start and Totalizer Reset

When using the Totalizer Function, the start setup should be done.

- (1) Start operation using BT200
Enter to B40(TOTAL START), and move the video bar to “EXECUTE”. Push “ENTER” key at 2 times.
- (2) Start operation using indicator
Enter to “Setting mode”, move to B40 of parameter number, and enter to “01” of data number.
Read Section 5.4 “Setting Mode.”

Totalized value can be reset using the indicator or BT200.

- (1) Reset operation using BT200
Enter to B42 (TOTAL RESET), and move the video bar to “EXECUTE”. Push “ENTER” key at 2 times.
- (2) Reset operation using indicator
Enter to “Setting mode”, move to B47 of parameter number, and enter to “01” of data Number.
Read Section 5.4 “Setting Mode.”

10.1.5 Setting of Pulse Output (Scaling)

Pulse output are constructed by two units, that are “Scaled pulse and Unscaled Pulse”.

(1) Scaled Pulse

When SCALED PULSE is selected in B20, set flowrate per one pulse output. Rate unit is linking to the flow unit.

(2) Unscaled Pulse

When UNSCALED PULSE is selected in B20, it outputs the pulse calculated by following formula. The formula for output pulse number is as follows. Output pulse number per one second = vortex number per one second / PULSE RATE set number.

Read Section 11.6 “Flow Calculation.”



● Pulse Rate setting

Pulse rate setting is settable by “B21:PULSE RATE”.

10.1.6 Setting of Burnout Switch

digitalYEWFLO is equipped with a CPU error burnout function used to set the output direction upon CPU error, and a sensor burnout function that sets the direction of the output in the event of burnout of the temperature sensor. When factory-shipment under normal conditions, the output of both CPU error burnout and sensor burnout are set to HIGH, but if option code /C1 is specified, the CPU error burnout is set to LOW(-2.5% below) output, and sensor burnout is set to LOW(-2.5% below) output, respectively. The setting of the direction of output from burnout can be changed. To change the direction of output arising from burnout, switch the setting pin on the CPU assembly (Read Table 10.1).

Table 10.1 Output Setting Pin for Burnout

| Pin position | CPU error burnout direction | CPU error burnout output | Remark |
|---|-----------------------------|--------------------------|---------------------------------|
|  H L | HIGH | 110% or more (21.6mA DC) | Set to HIGH before shipment. |
|  H L | LOW | -2.5% or less (3.6mA DC) | Set to LOW for option code /C1. |

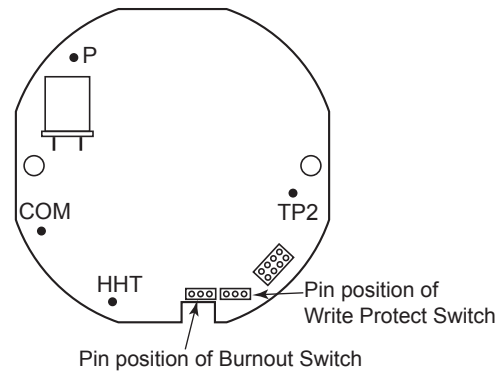

F1002.ai

Figure 10.2 Pin position of Burnout and Write Protect Switch

10.1.7 Setting of Write Protect Switch

By setting the write protect function to “Protect”, it is possible to prevent the overwriting of parameters. Write protection can be carried out using either the hardware switch on the CPU board (i.e., Switch 2) or software parameter settings. If either of these items is set to “Protect”, the overwriting of parameters will be prohibited.



NOTE

If the hardware switch is set to “Protect”, it will not be possible to overwrite parameters; furthermore, this condition will be maintained until the switch is set to “Enable”.

For more details regarding usage of the write protect function and the software’s parameter switches, read Section 8.9 “Software Write Protect” or Section 9.9 “Software Write Protect.”

Table 10.2 Setting pin for Write Protect

| Pin position | CPU error burnout direction |
|--------------|-----------------------------|
| | Enable |
| | Protect |

10.1.8 Power Failure

When a power failure occurs, the totalized value will be protected by EEPROM (Electrically Erasable Programmable ROM). But during a power failure, the vortex flowmeter stops and also the totalizing will stop.

After a power is recovered, the vortex flowmeter and the totalizing start to work automatically. EEPROM doesn’t need a battery for backup.

10.2 Adjustment for Manual Mode

digitalYEWFL0 does not need the initial adjustment because digitalYEWFL0 is always adjusted by itself automatically.

These adjustments should be done in case that indicator reads over zero at zero flow.

10.2.1 Low Cut Adjustment

Adjust to noise elimination or zero flow in the low flowrate (or low frequency) range.

The settable range for low cut flowrate is to half of minimum flowrate.

10.2.2 Zero Tuning

This adjustment should be done according to a flow figure shown below.

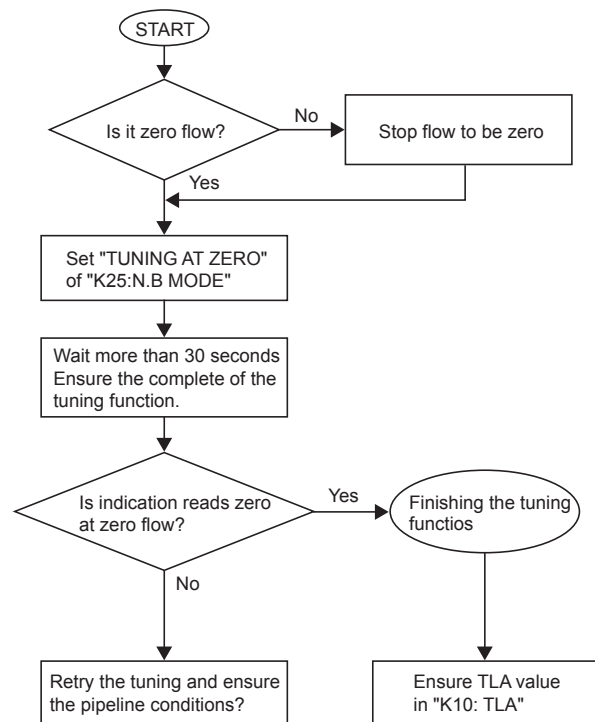

F1003.ai

Figure 10.3 Tuning Flow

If this adjustment is executed, the following value is changed.

K25:N.B MODE = MANUAL

K26:NOISE RATIO=Constant value

Minimum flowrate is increased when TLA value is changed form initial value.

1. Tuning method

(1) Ensure the condition of flowrate
The necessary condition for tuning function is zero flow.

(2) Executing the tuning function.
Set "TUNING AT ZERO" of "K25:N.B MODE".
Wait more 30 second.

(3) Finishing the tuning functions

Using the BT200

- (a) Press "DATA" key of BT200 function key.
- (b) Ensure the indication of "MANUAL" which is "K25:N.B MODE" ("NOW TUNING" is indicated during tuning operation.)

Using the indicator

- (a) Press "SHIFT" and "SET" key simultaneously.
- (b) Press "SET" key and ensure "01" of Lower indication. ("02" is indicated during tuning operation. Execute (a), (b) once again.)

2. TLA value

TLA values is possible to change after executing "TUNING". In this case, minimum flowrate is increased.

Minimum flowrate for TLA value is given by below equation.

$$\text{Minimum Flowrate after changing TLA Value} = \text{Specified Minimum Flowrate} \times \sqrt{\frac{\text{TLA Value after Tuning}}{\text{TLA initial value or default value}}}$$

F1004.ai

Ensure minimum flowrate for changing TLA value.

3. Output

After tuning, ensure that the indication reads is zero where no fluid is flowing.

If the indication reads over zero is done continuously, retry the tuning and ensure the below condition.

Does high vibrations occur in pipeline?

In this case, read Section 3.1 "Installation Precautions", and keep the pipeline properly.

11. MAINTENANCE



CAUTION

- Only our factory can repair and disassemble this instrument.
 - Maintenance work must be carried out by expert engineer or skilled personnel and not by operators.
 - Before opening the cover, it is important to ensure that at least 10 minutes have passed since the power was turned off. Furthermore, opening of the cover must also be carried out by expert engineer or skilled personnel.
-



CAUTION

- It is prohibited by law for the user to modify flameproof instruments. It is not permitted to add or remove indicators. If modification is required, contact YOKOGAWA.
 - Explosion protected type must be, as a rule, removed to a non-hazardous area for maintenance and be disassembled and reassembled to the original state.
 - For TIIS and ATEX explosion protected type, the display cover is locked by the Locking Screw. In case of opening the display cover, use the hexagonal wrench attached.
 - Be sure to lock the cover by the Locking Screw using the hexagonal wrench attached after installing the cover.
-

11.1 Changing the Converter and the Terminal Box Orientation

The converter and the terminal box can be changed in four directions with respect to the flow direction.

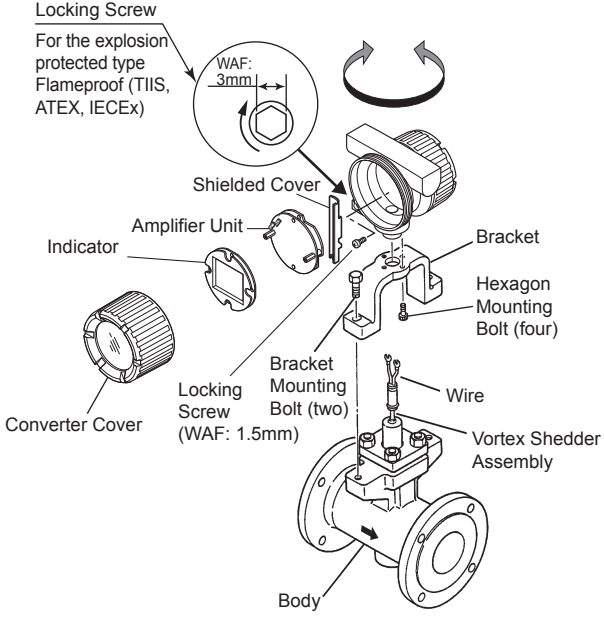
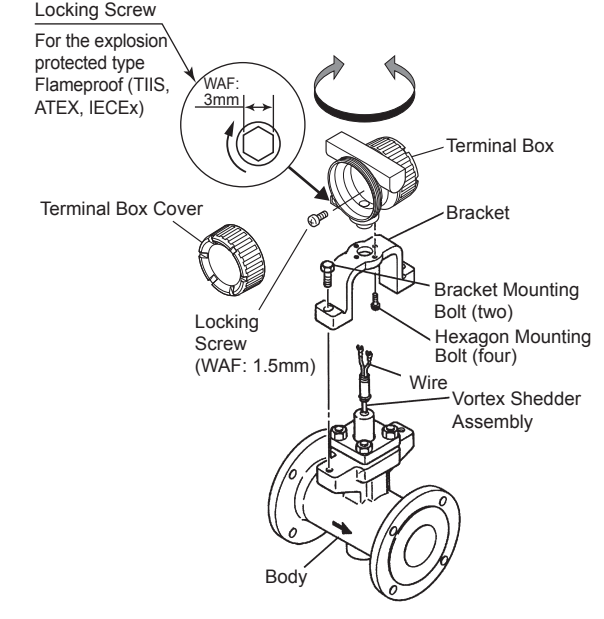
| Integral Type Vortex Flowmeter | Remote Type Vortex Detector |
|--|---|
| <p><1> Remove the converter cover. In case of the explosion protected type cover removal, loosen the Locking Screw (WAF: 3mm).</p> <p><2> For indicator and amplifier unit removal, read Section 11.2 "Indicator Removal and Rotation" and Section 11.3 "Amplifier Unit Removal".</p> <p><3> Disconnect the vortex shedder assembly lead-wires from the converter. In case of the explosion protected type, loosen the Locking Screw (WAF: 1.5mm).</p> <p><4> Remove the bracket mounting bolts and remove the converter and bracket from the flowmeter body. The bracket applies to the 1 (25mm) to 4 (100mm) inch flowmeters.</p> <p><5> Remove the hexagon mounting bolts in case of 90-degree turn.</p> <p><6> Turn the converter to the desired orientation. When reassembling the converter, reverse the above procedure.</p> <p><7> After changing the direction, make sure the impedance between the earth terminal and the metal part of body, vortex shedder assembly or bracket is 100Ω or less.</p>  | <p><1> Remove the terminal box cover. In case of the explosion protected type cover removal, loosen the Locking Screw (WAF: 3mm).</p> <p><2> Disconnect the vortex shedder assembly lead-wires from the terminal box. In case of the explosion protected type, loosen the Locking Screw (WAF: 1.5mm).</p> <p><3> Remove the bracket mounting bolts and remove the terminal box and bracket from the flowmeter body. The bracket applies to the 1 (25mm) to 4 (100mm) inch flowmeters.</p> <p><4> Remove the hexagon mounting bolts in case of 90-degree turn.</p> <p><5> Turn the terminal box to the desired orientation. When reassembling the terminal box, reverse the above procedure.</p> <p><6> After changing the direction, make sure the impedance between the earth terminal and the metal part of body, vortex shedder assembly or bracket is 100Ω or less.</p>  |

F1101.ai

11.2 Indicator Removal and Rotation



IMPORTANT

For Explosion protected type, modification by the user is prohibited. It is prohibited to add or remove the indicator.



CAUTION

- For flameproof type, move vortex flowmeter to non-hazardous area firstly, then remove and rotate the indicator. The instrument must be restored to its original condition.
- For flameproof type, when you open the cover, turn the locking screw to the right and unlock. When you close the cover, be sure to turn the locking screw to the left and lock.
- For TIIS flameproof type, read “INSTALLATION AND OPERATING PRECAUTIONS FOR TIIS FLAMEPROOF EQUIPMENT” at the end of this User’s manual.

- (1) Turn the power off.
- (2) Remove the cover.
In case of the Explosion protected type, remove the cover after unlock the Locking Screw.
- (3) For the indicator, disconnect the cable connector from the amplifier unit.
- (4) Loosen the two indicator mounting screws using a Phillips screwdriver.
- (5) Pull out the indicator.
- (6) Reinstall the indicator in the reverse order to its removal (above) and secure the mounting screws.

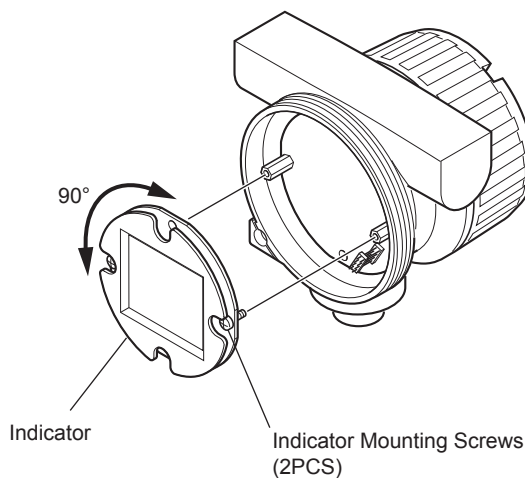

Figure 11.1 Removing and Reinstalling the Indicator

F1102.ai

11.3 Amplifier Unit Removal



IMPORTANT

Do not turn the amplifier unit for removal or assembling. The connector pins may be damaged.

- (1) Turn the power OFF.
- (2) Remove the converter cover.
In case of the Explosion protected type, remove the cover after unlock the Locking Screw.
- (3) Remove the indicator according to the procedures described in Section 11.2 “Indicator Removal and Rotation.”
- (4) Loosen the terminal screws and remove the amplifier unit.

11.4 Amplifier Unit Assembling



IMPORTANT

The amplifier unit must be assembled keeping the procedure as follows. Amplifier may not operate normally when the procedure does not keep.

- (1) Put two Mounting Pins ① into Mounting Holes ②.
- (2) Push the head of two Mounting Screws ④ lightly.
- (3) Push head of two IC ⑤ and mount the Amplifier Unit ③.
- (4) Tighten two Mounting Screws ④.

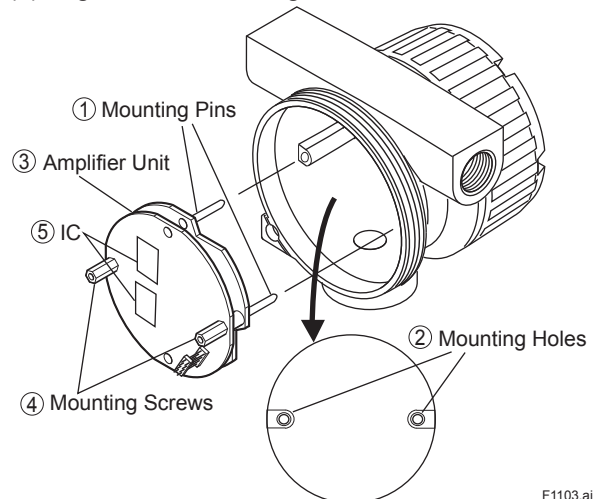

F1103.ai

Figure 11.2 Removing and Reinstalling the Amplifier Unit

11.5 Vortex Shedder Removal



CAUTION

- Disassemble work should be done only for error occurrence.
 - Only expert engineer or skilled personnel are permitted to open the cover.
 - When the vortex shedder is disassembled, and empty the flow tube before the gasket must be replaced with a new one.
 - Output error may cause when the shedder bar is not restored correctly.
 - For Explosion protected type, move vortex flowmeter to non-hazardous area firstly, then do the assemble work.
-
- (1) For nominal size 15 to 100mm (1/2 to 4 inch), remove the converter cover or terminal box according to the following (2) to (5). For nominal size 150 to 400mm (6 to 16 inch), this procedure is not necessary.
 - (2) For integral type, remove the converter cover. For remote type, remove the terminal cover. For integral type, loosen the hexagonal screw on the Amplifier unit, then remove the amplifier unit. Remove the indicator first, in case the device has it.
 - (3) For integral type, remove the Shielded cover back Amplifier unit. In case of following Explosion protected type, loosen the locking screw on the converter case or terminal box. Explosion protected type: TIIS Flame proof, ATEX Explosion proof, IECEx Flame proof
 - (4) Remove the Leadwire by loosening a screw on the terminal strip.
 - (5) Loosen the bracket mounting bolts and remove the converter case or terminal box together with the bracket. Be careful not to damage the leadwires of the vortex shedder assembly.
 - (6) Loosen the vortex shedder assembly mounting bolts (2 to 10 pcs) and remove the vortex shedder assembly.
 - (7) When reassembling the vortex shedder assembly, reverse above procedure. Confirm the following.
 - a. Replace to a new gasket.
 - b. The guide pin on the vortex shedder mounting block meets the guide pin hole. Read Figure 11.3. Nominal size 150 to 400mm (6 to 16 inch) has no guide pin.

- c. The vortex shedder assembly is installed as illustrated in Figure 11.3.
- d. Tighten the sensor mounting bolts uniformly and diagonally in three or four times. Read Table 11.1, 11.2 and Figure 11.4.

Table 11.1 Torque Value

| Model Code | | | Torque Value UNIT: N·m | | |
|------------|-----------|-----------|------------------------|-----|-----|
| | | | Standard, /NC, /LT | /HT | |
| | | A | | B | |
| DY015 | DY025 /R1 | DY040 /R2 | 16 | | |
| DY025 | DY040 /R1 | DY050 /R2 | 12 | 18 | 12 |
| DY040 | DY050 /R1 | DY080 /R2 | 12 | 18 | 12 |
| DY050 | DY080 /R1 | DY100 /R2 | 18 | 27 | 18 |
| DY080 | DY100 /R1 | DY150 /R2 | 32 | 48 | 32 |
| DY100 | DY150 /R1 | DY200 /R2 | 49 | 74 | 49 |
| DY150 | DY200 /R1 | — | 69 | 98 | 69 |
| DY200 | — | — | 69 | 98 | 69 |
| DY250 | — | — | 157 | 210 | 140 |
| DY300 | — | — | 157 | 210 | 140 |
| DY400 | — | — | 160 | 240 | 160 |

/HT: High Process Temperature Version
 /LT: Cryogenic Version
 /NC: NACE Material

Table 11.2 Torque Value (Process connection code BA6 and CA6)

| Model Code | Torque Value UNIT: N·m | |
|------------|----------------------------------|--|
| | Process connection code BA6, CA6 | |
| DY025/R1 | 12 | |
| DY040/R1 | 37 | |
| DY050/R1 | 37 | |
| DY080/R1 | 37 | |
| DY100/R1 | 50 | |
| DY150/R1 | 78 | |

- e. In case of High Process Temperature Version (Option code: /HT), First time tighten bolts with a torque wrench, applying the torque specified "A". Next time loosen bolts then again tighten bolts with a torque wrench, applying the torque specified "B". For loosing process, be sure not to loose bolts completely.
- f. Insert the leadwires (vortex shedder) through the terminal box bottom hole and lower the terminal box slowly until the bracket touches the flowmeter shoulder. Be sure to keep the leadwires vertical while lowering the terminal box.
- g. After assembling, confirm that there is no leakage from the vortex flowmeter.



IMPORTANT

- Tighten the screws/bolts uniformly and observing the torque value in Table 11.1.
- Read the annex of the manual carefully for the special specification products.

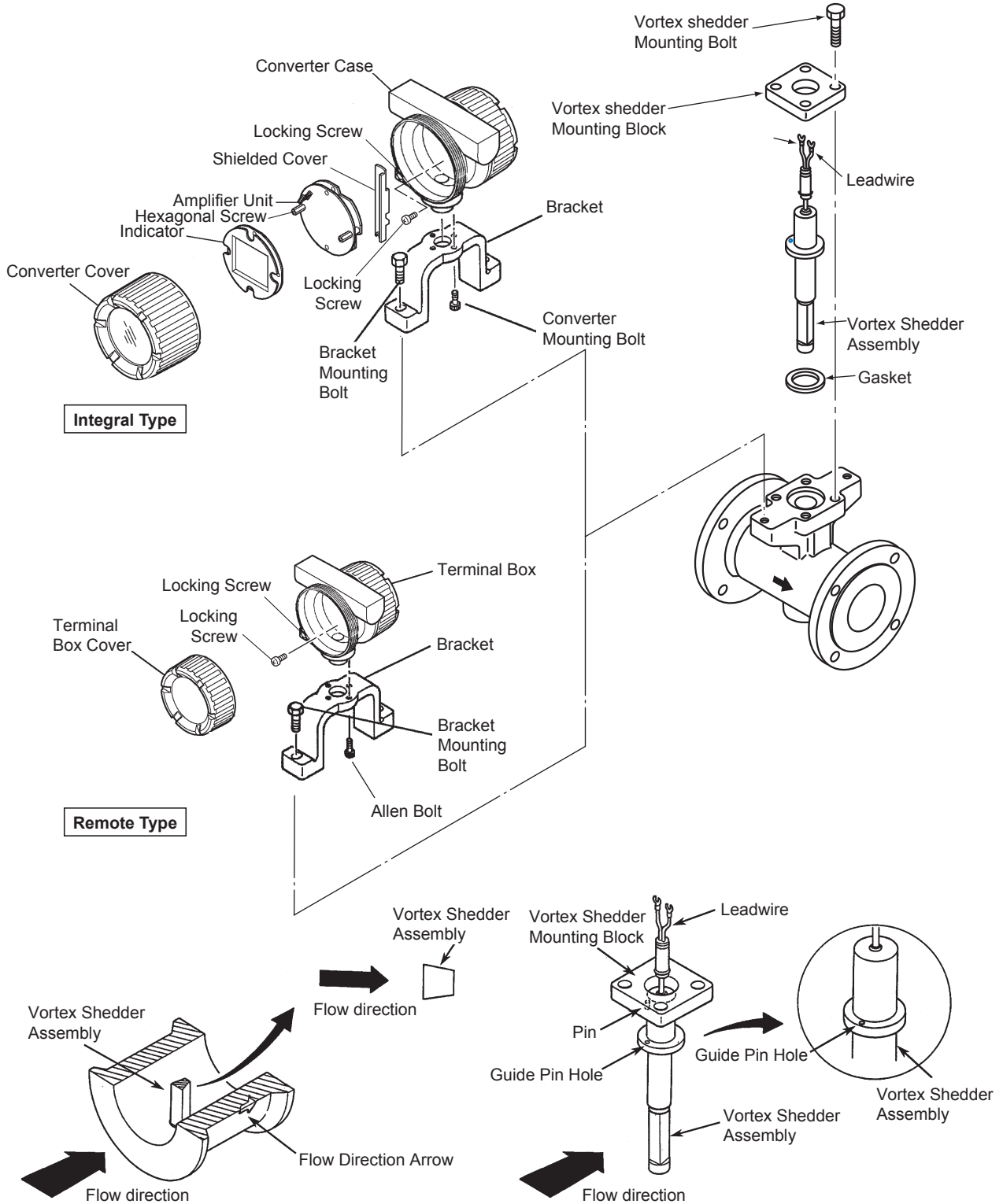

F1104.ai

Figure 11.3 Disassembling and Reassembling the Vortex Shedder Assembly

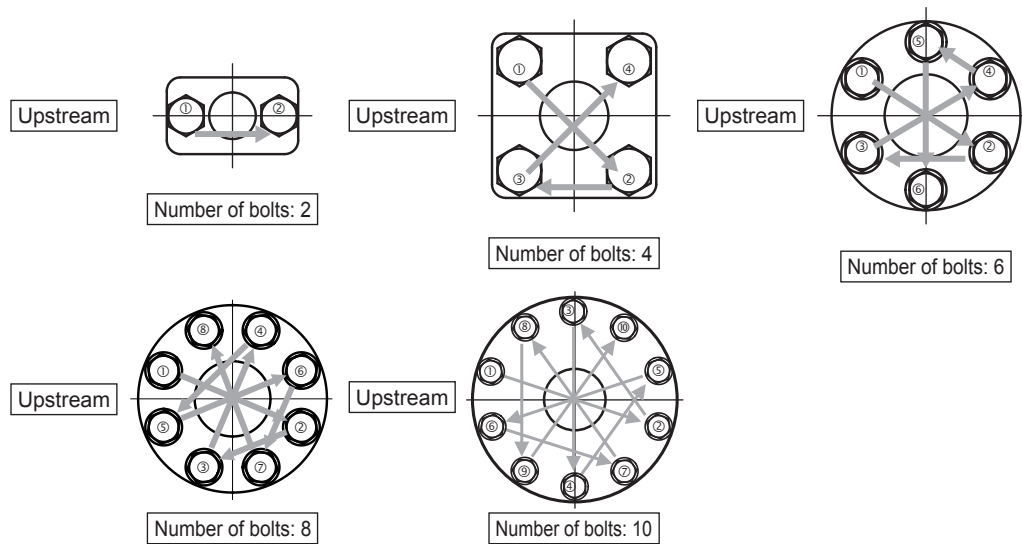

F1105.ai

Figure 11.4 Procedure of tightening bolts

11.6 Flow Calculation

(1) Flow Calculation

The flowrate is calculated with the following equations based on the N number of generated vortices:

(a) Flow rate (in engineering units) (RATE)

$$RATE = N \times \frac{1}{\Delta t} \times \epsilon_f \times \epsilon_e \times \epsilon_r \times \frac{1}{KT} \times U_k \times U_{TM} \quad \dots (11.1)$$

• Metric Units

$$KT = KM \times U_{KT} \times \{1 - 4.81 \times (T_f - 15) \times 10^{-5}\} \quad \dots (11.2.1)$$

• English Units

$$KT = KM \times \{1 - 2.627 \times (T_f - 59) \times 10^{-5}\} \quad \dots (11.2.2)$$

(b) Flow rate (%) (RATE (%))

$$RATE(\%) = RATE \times \frac{1}{F_s} \times 100 \quad \dots (11.3)$$

(c) Totalized value (TOTAL)

$$TOTAL = TOTAL + \Delta TOTAL \quad \dots (11.4)$$

$$\Delta TOTAL = RATE \times \Delta t \times \frac{1}{T_R} \times \frac{1}{U_{TM}} \quad \dots (11.5)$$

(d) Pulse output frequency (PULSE FREQ)

• Scaled pulse

$$PULSE \ FREQ = RATE \times \frac{1}{P_R} \times \frac{1}{U_{TM}} \quad \dots (11.6.1)$$

• Unscaled pulse

$$PULSE \ FREQ = N \times \frac{1}{\Delta t} \times \frac{1}{P_R} \quad \dots (11.6.2)$$

(e) Velocity (V)

$$V = N \times \frac{1}{\Delta t} \times \frac{1}{KT} \times U_{KT} \times \frac{4}{\pi \times D^2} \quad \dots (11.7)$$

(f) Reynolds number (Re)

• Metric Units

$$Re = V \times D \times \rho_f \times \frac{1}{\mu} \times 1000 \quad \dots (11.8.1)$$

• English Units

$$Re = V \times D \times \rho_f \times \frac{1}{\mu} \times 124 \quad \dots (11.8.2)$$

Where

- N: Number of input pulses (pulse)
- Δt : Time corresponding to N (seconds)
- ϵ_f : Instrumental error correction factor
- ϵ_e : Expansion correction factor for compressive fluid
- ϵ_r : Reynolds number correction factor
- KT: K-factor at operating conditions (pulses/litre) (pulse/gal)
- KM: K-factor at temperature 15°C (59°F)
- U_{KT} : Unit conversion factor for K-factor
- U_k : Flow unit conversion factor (Read item (2))
- $U_{k(user)}$: Flow unit conversion factor for user's unit
- U_{TM} : Factor corresponding to flow unit time (ex./m (minute) is 60.)
- P_R : Pulse rate (ex. E+ 3 is 10^3 .)
- T_f : Temperature at operating conditions (°C) (°F)
- F_s : Flowrate span
- T_R : Total rate
- D: Internal diameter (m) (inch)
- μ : Viscosity (mPa • s(cP))
- ρ_f : Density at operating conditions (kg/m³) (lb/ft³)

(2) Flow Conversion Factor (U_k)

Flow conversion factor U_k is obtained by carrying out the following computation depending on the selection of the fluid to be measured and the flow unit.

(a) Steam

M (Mass flowrate):

$$U_k = \rho_f \times U_{\rho_f} \times U_{k(kg)} \dots (11.9.1)$$

$$U_k = \rho_f \times U_{k(lb)} \dots (11.9.2)$$

Q_f (Flowrate at operation):

$$U_k = U_{k(m^3)} \dots (11.10.1)$$

$$U_k = U_{k(acf)} \dots (11.10.2)$$

(b) Gas

Q_n (Flowrate at STP):

$$U_k = \frac{P_f}{P_n} \times \frac{T_n + 273.15}{T_f + 273.15} \times \frac{1}{K} \times U_{k(Nm^3)} \dots (11.11.1)$$

$$U_k = \frac{P_f}{P_n} \times \frac{\frac{5}{9}(T_n - 32) + 273.15}{\frac{5}{9}(T_f - 32) + 273.15} \times \frac{1}{K} \times U_{k(scf)} \dots (11.11.2)$$

M (Mass flowrate):

$$U_k = \rho_f \times U_{\rho_f} \times U_{k(kg)} \dots (11.12.1)$$

$$U_k = \rho_f \times U_{\rho_f} \times U_{k(lb)} \dots (11.12.2)$$

Q_f (Flowrate):

$$U_k = U_{k(m^3)} \dots (11.13.1)$$

$$U_k = U_{k(acf)} \dots (11.13.2)$$

(c) Liquid

Q_f (Flowrate):

$$U_k = U_{k(m^3)} \dots (11.14.1)$$

$$U_k = U_{k(acf)} \dots (11.14.2)$$

M (Mass flowrate):

$$U_k = \rho_f \times U_{k(kg)} \dots (11.15.1)$$

$$U_k = 7.481 \times \rho_f \times U_{k(lb)} \dots (11.15.2)$$

Note: 7.481 is a conversion factor of U.S gal into acf

(d) User's unit

$$U_k = U_{k(user)} \dots (11.16)$$

U_{ρf}: Density unit conversion factor

$$U_{k(kg)}, U_{k(Nm^3)}, U_{k(m^3)}$$

U_{k(lb)}, U_{k(scf)}, U_{k(acf)}}: Flow rate unit conversion factor}}

(3) Mass Flow calculation

(a) Steam

In case of saturated steam, mass flow rate is calculated from density values to temperature measured by using saturated steam table.

In case of superheat steam, mass flow rate is calculated from density values to temperature measured by using steam table. In order to measure superheat steam, it is necessary to make constant pressure value. A pressure values which is entered in parameter is used.

$$M = \rho_{ft} \times Q_f \dots (11.17)$$

(b) Gas

In case of gas, Volumetric flow rate at standard condition is calculated, so Pressure-Temperature correction is carried out. It is necessary to make constant pressure value. A Pressure values at operational condition, temperature and pressure value at standard condition which is entered in parameter is used.

$$Q_n = Q_f \times \frac{P_f}{P_n} \times \frac{T_n + 273.15}{T_{ft} + 273.15} \times \frac{1}{K} \dots (11.18)$$

(c) Liquid

In case of liquid, mass flow rate is calculated from which used to calculate the secondary function for the density value to the temperature. A density value which indicated by the order sheet is used.

$$M = \rho_n \times Q_f \times \{1 + a_1 \times (T_{ft} - T_n) \times 10^{-2} + a_2 \times (T_{ft} - T_n)^2 \times 10^{-6}\} \dots (11.19)$$

[Footnote]

$$a_1 = \{(k_1 - 1) \times \Delta T_2^2 - (k_2 - 1) \times \Delta T_1^2\} / \{(\Delta T_1 \times \Delta T_2^2 - \Delta T_2 \times \Delta T_1^2) \times 10^{-2}\}$$

$$a_2 = \{(k_1 - 1) \times \Delta T_2 - (k_2 - 1) \times \Delta T_1\} / \{(\Delta T_1^2 \times \Delta T_2 - \Delta T_2^2 \times \Delta T_1) \times 10^{-6}\}$$

$$k_x = 1 + a_1 \times \Delta T_x \times 10^{-2} + a_2 \times \Delta T_x^2 \times 10^{-6}$$

$$\Delta T_x = T_x - T_n$$

$$(x = 1, 2)$$

Where

M : Mass flow

Q_n : Volumetric flow rate at standard condition

Q_f : Volumetric flow rate at operating condition

T_n : Temperature at operating condition ($^{\circ}\text{C}$), ($^{\circ}\text{F}$)

T_f : Temperature at standard condition ($^{\circ}\text{C}$), ($^{\circ}\text{F}$)

T_{ft} : Measured temperature value ($^{\circ}\text{C}$), ($^{\circ}\text{F}$)

P_f : Pressure at operating condition (kPa abs), (psi)

P_n : Pressure at standard condition (kPa abs), (psi)

K : Deviation factor

ρ_{ft} : Density calculated by temperature value

ρ_n : Density at standard condition (kg/m^3), (lb/cf)

ρ_f : Density at operating condition

U_{pf} : Density unit conversion factor

$U_{k(\text{kg})}$, $U_{k(\text{Nm}^3)}$, $U_{k(\text{m}^3)}$: Flow rate unit conversion factor

a_1 : 1st temperature coefficient

a_2 : 2nd temperature coefficient

Example: conversion factor in kg.

kg : $U_{k(\text{kg})} = 1$

ton : $U_{k(\text{kg})} = 0.001$

12. TROUBLESHOOTING



CAUTION

Please avoid replacing the amplifier unit from the case, and the vortex shedder bar. When these procedures are needed, please contact the nearest Yokogawa office.

12.1 Large Errors or Unstable Output

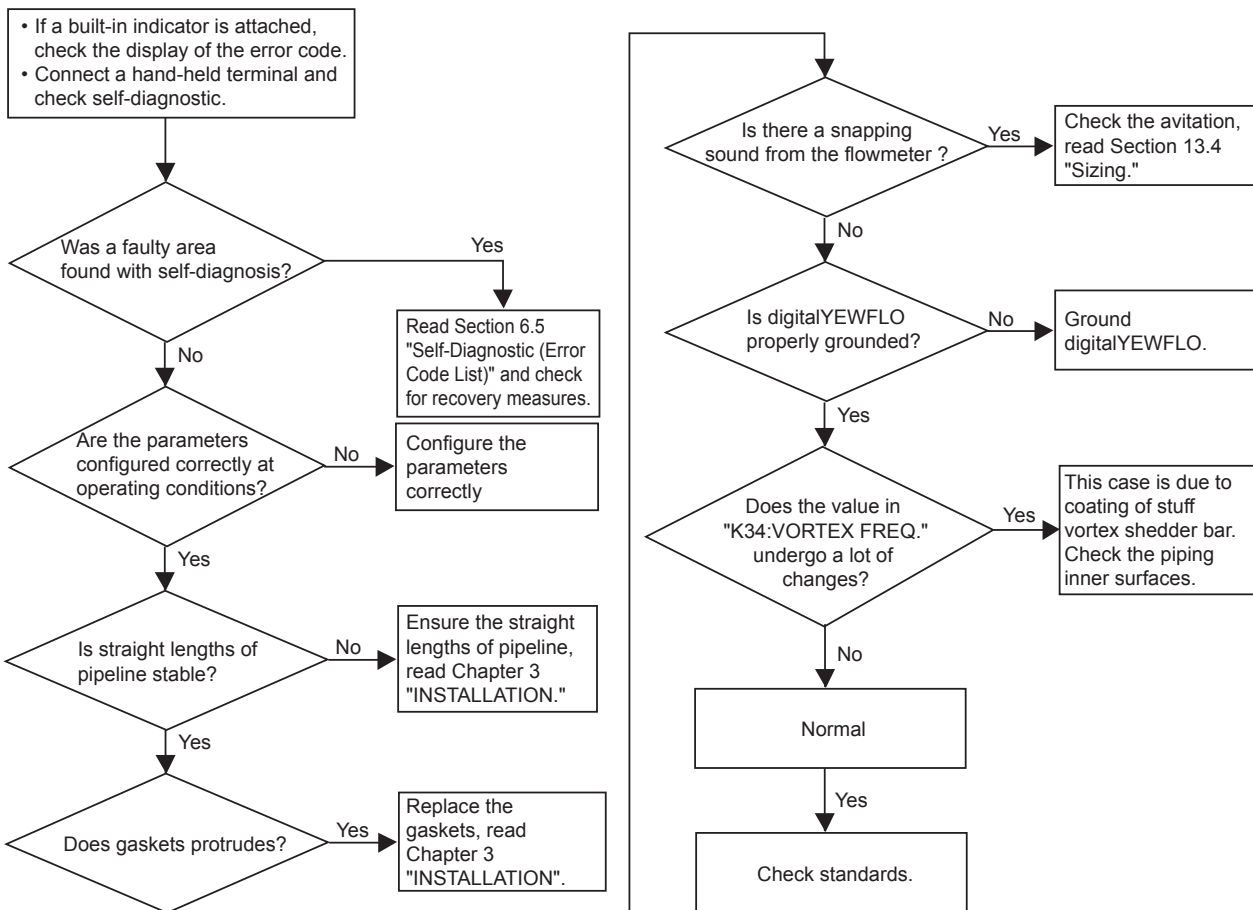

Note 1: This is the temperature and pressure at digitalYEWFLO mounted place.

Note 2: Contact with our service in case this is not carried into the right statement.

F1201.ai

12.2 The Indication Goes to Zero at Certain Time

When this problem occurred, the cause is suspected of deterioration of sensor sensitivity and turbulent of fluid flow due to coating on the shedder bar and flowmeter inner tube.

How to cope with this problem

- 1) Read Section 11.5 "Vortex Shedder Removal," take out the Vortex Shedder bar and clean it.
- 2) If there is the coating on inner tube of the flowmeter, remove the flowmeter body from adjacent pipes and clean it.

12.3 No Output When The Fluid is Flowing

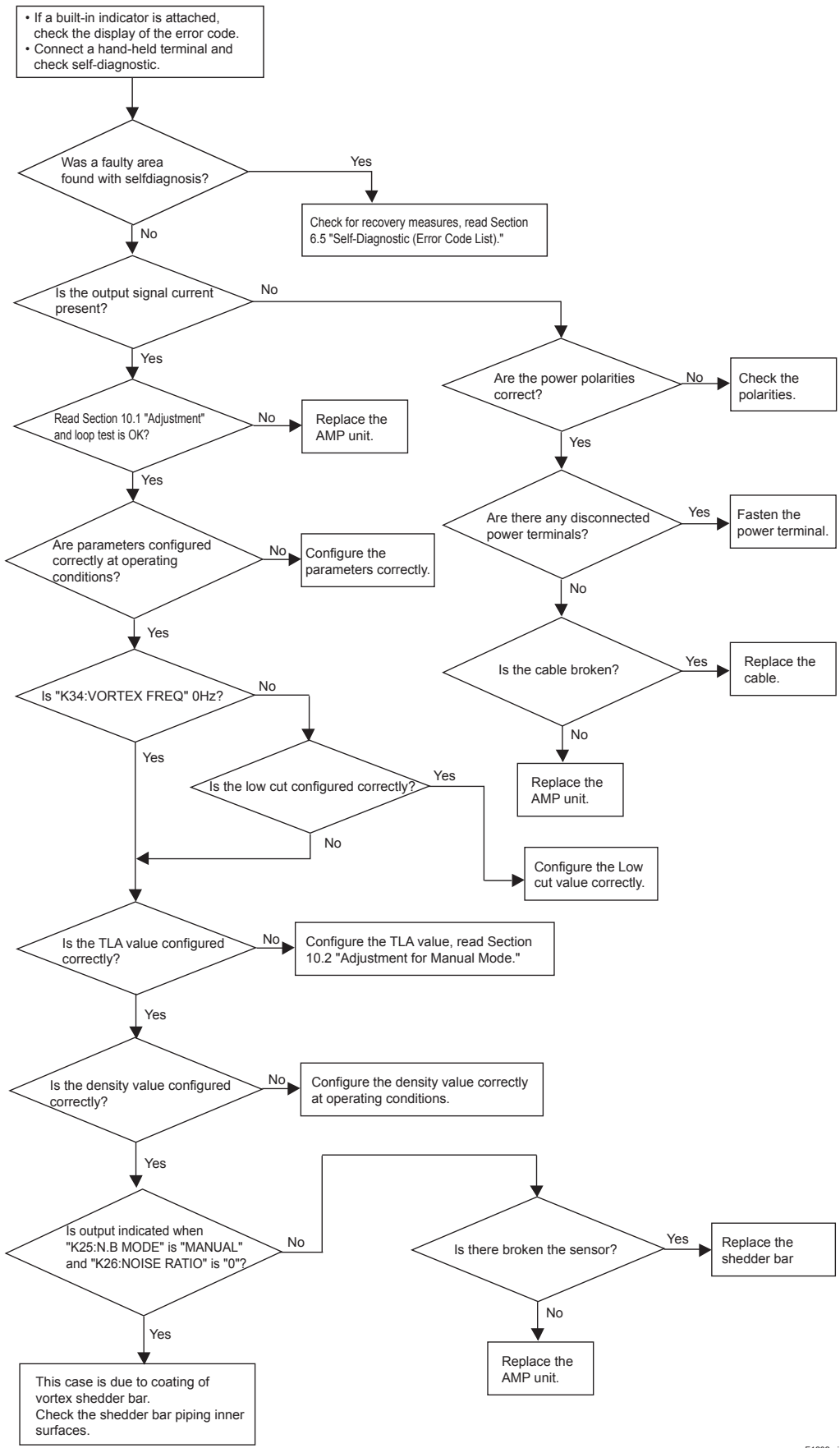

F1202.ai

12.4 Output is Indicated at Zero Flow

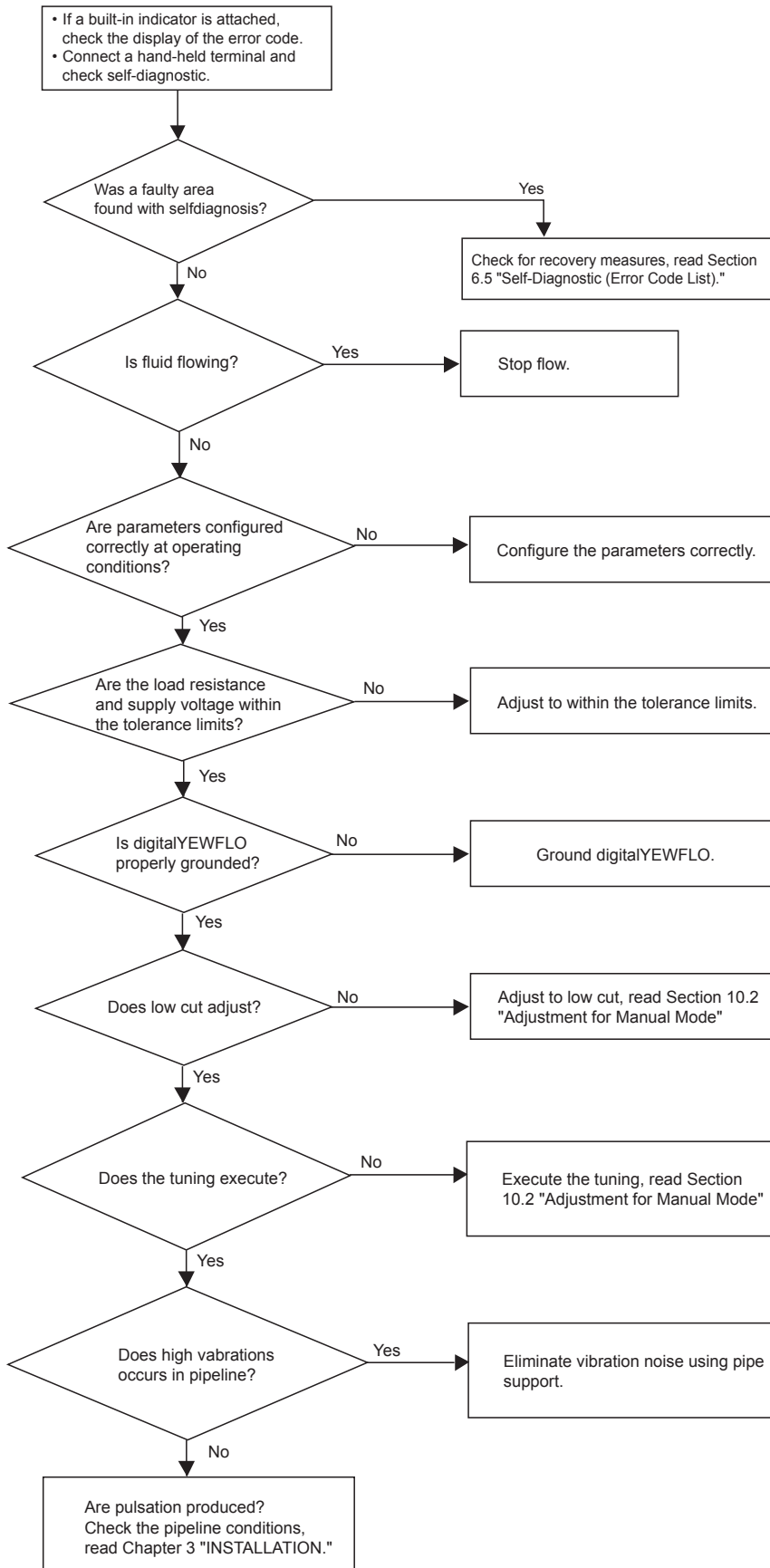

F1203.ai

12.5 Multi-Variable Type (/MV)

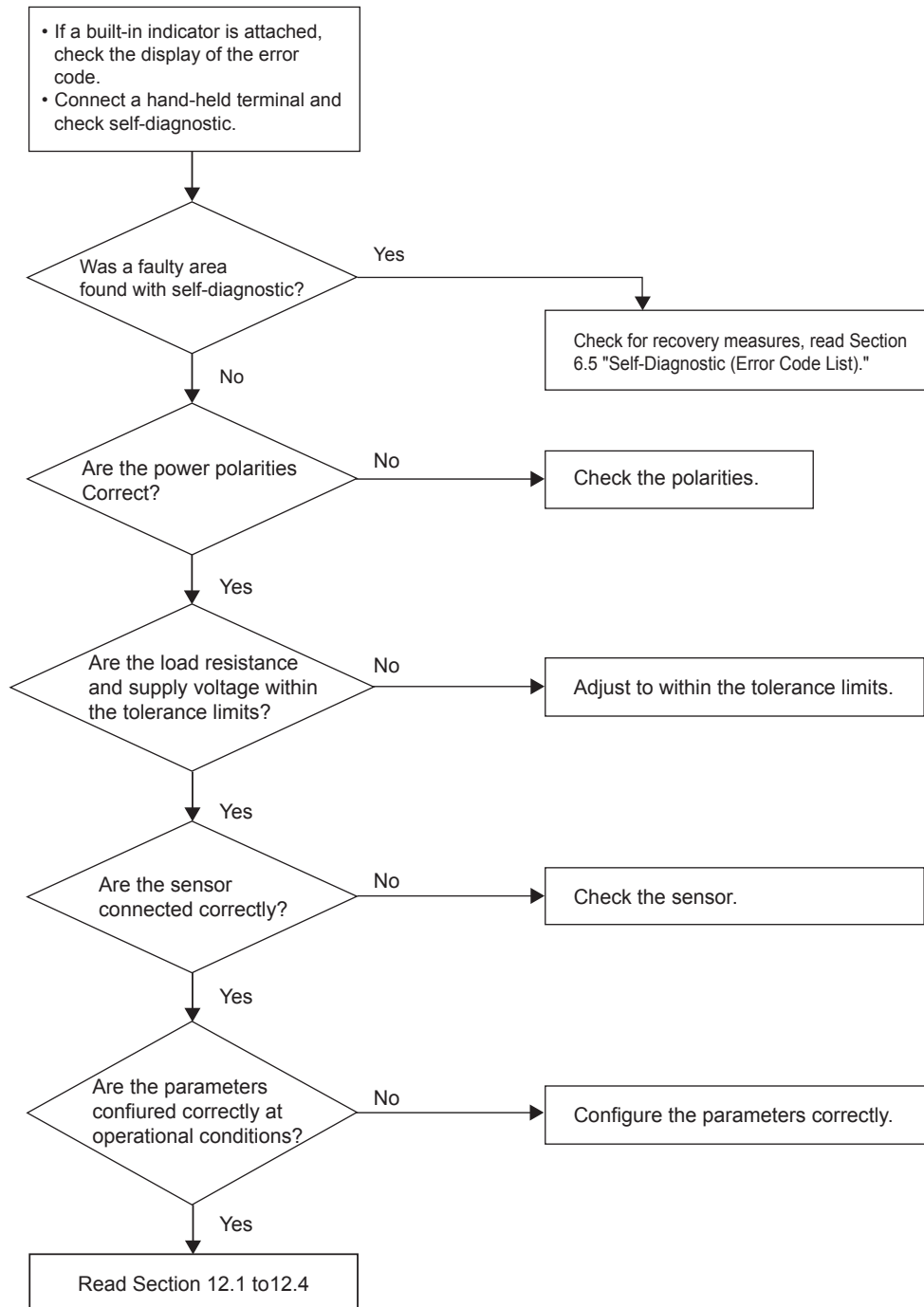

F1204.ai

13. GENERAL SPECIFICATIONS

13.1 Standard Specifications

■ Communication function includes FOUNDATION fieldbus, BRAIN and HART protocol.
Read GS 01F06F01-01EN for Fieldbus communication type marked with “◇”.

Performance Specifications

Fluid to be Measured:

Liquid, Gas, Steam (Avoid multiphase flow and sticky fluids)

Measuring Flow Rates:

Read Table 13.6

Accuracy: ±0.75% of Reading (Liquid)

±1% of Reading (Gas, Steam)

Read Section 13.5 “Detailed Accuracy.”

/MV: Read Subsection 13.3.1 “Option Multi-Variable (Built-In Temperature Sensor) Type (/MV).”

Repeatability: ± 0.2% of Reading

Calibration:

This flowmeter is factory-calibrated using a water flow.

Temperature and flow calibration by water flow when Multi-Variable Type is selected.

Normal Operating Condition

Process Temperature Range:

–29 to +250 °C (Standard)

–196 to +100 °C (Cryogenic Version: Option)

–29 to +450 °C (High Process Temperature Version: Option)

–29 to +400 °C (High Process Temperature Version Multi-Variable Type: Option)

When Multi-Variable Type is selected, read Subsection 13.3.1 “Option Multi-Variable (Built-In Temperature Sensor) Type (/MV).”
Read Figure 13.1 for integral type.

Process Pressure Limit:

–0.1MPa (–1 kg/cm²) to flange rating.

Ambient Temperature Range:

–29 to +85 °C (Remote Type detector)

–40 to +85 °C (Remote Type converter)

–29 to +85 °C (Integral Type, read Figure 13.1)

–29 to +80 °C (Integral Type with Indicator, read Figure 13.1)

–30 to +80 °C (Remote Type converter with Indicator)

–40 to +85 °C (Cryogenic Version: Option)

Ambient Humidity: 5 to 100% RH (at 40 °C)
(No Condensation)

Power Supply Voltage (◇): 10.5 to 42 V DC
10.5 to 30 V DC (Lightning Protector: option)
(Read Figure 13.2 ; Relationship Between Power Supply Voltage and Load Resistance)

Mechanical Specifications

Material (Standard Type):

Read Table.13.1

Wetted Parts:

Body*1; Stainless steel SCS14A, CF8M

*1 Flange materials for DY250 to DY400 are SUS F304

Shedder Bar; Duplex stainless steel

Size 15mm S31803

Size 25mm to 400mm 1.4517

Gasket: SUS316 stainless steel with PTFE coating.

Non-Wetted Parts:

Housing (Case, Cover):

Aluminum alloy ADC12

Name Plate: Stainless steel SUS304

DYA Mounting Bracket for 2B pipe:

Carbon steel

Coating Color:

Housing:

Polyurethane corrosion-resistant coating

Mint green (Munsell 5.6BG 3.3/2.9 equivalent)

DYA Mounting Bracket for 2B pipe:

Polyurethane corrosion-resistant coating

Frosty white (Munsell 2.5Y 8.4/1.2 equivalent)

Degree of Protection:

IP66/IP67 (IEC 60529), Type 4X (NEMA 250)

Type of Protection:

Read Section 13.3 “Option Specifications”.

Electrical Connection:

JIS G1/2 female, ANSI 1/2 NPT female,

ISO M20 × 1.5 female

Signal Cable:

DYC remote type signal cable, used for remote detector and converter.

Signal cable length is up to 30 m.

Outer Sheath Material: Heat resisting polyethylene

Durable Temperature: –40 to +150 °C

Weight:

Read Section 13.7 "External Dimensions".

Mounting:

Integral type and Remote type detector:
Flange mounting or wafer mounting by flange adjacent to the pipeline.

Remote type converter: 2 inch pipe mounting.

Electrical Specifications

Note*: Pulse output, alarm output and status output use the common terminal, therefore these functions are not used simultaneously.

Output Signal (◇): Dual Output (Both Analog and Transistor contact output can be obtained simultaneously). In this case read Section 3.2 "Piping Precautions" for power supply and pulse output wiring.

Analog: 4 to 20 mA DC, 2-wire system.

Transistor Contact Output*:

Open collector, 3-wire system.
Pulse, alarm, status output are selected by parameter setting.

Contact rating: 10.5 to 30 V DC, 120 mA DC*1

Low level: 0 to 2 V DC. (read Figure 13.3)

*1: 10.5 to 30V DC, 80mA DC for ATEX Intrinsically Safe Approval (/KS2) and IECEx Intrinsically Safe Approval (/SS2)

Communication Requirements:

Communication Signal:

BRAIN or HART communication signal (superimposed on a 4 to 20 mA DC signal)

Note: HART is a registered trademark of the HART Communication Foundation.

Conditions of Communication Line:

Load Resistance:

250 to 600 Ω (including cable resistance).

Read Figure 13.2.

Supply Voltage:

16.4 to 42 V DC for digital communications BRAIN and HART protocols. (16.4 to 30 V DC for intrinsically safe type).

Read Figure 13.2.

BRAIN:

Space from other Power Line: 15cm or more (Parallel wiring should be avoided.)

Communication Distance:

Up to 2 km, when polyethylene insulated PVC-sheathed cables (CEV cables) are used. Communication distance varies depending on type of cable used and wiring.

Load Capacitance: 0.22 μF or less

Load Inductance: 3.3 mH or less

Input Impedance Communicating Device:

10 kΩ or more at 2.4 kHz.

Selection of HART 5/ HART 7

| Output Signal Code | | -E | -J | |
|------------------------|--------------------------------------|--|--|---|
| Ordering Information | | — | Specify "5" | Specify "7" |
| HART Protocol Revision | | HART 5 | | HART 7 |
| Selection guide | Requirement for HART 7 functionality | NO | | YES Be sure to confirm the protocol revision of the HART configuration tool shown in *2. |
| | Other conditions | Not available to switch to HART 7 protocol after delivery. | Available to switch to HART 7 protocol after delivery by user configuration. | — |
| Remarks | | *1 | *2 | *2 |

*1: "-E" is HART5 exclusive model and will be terminated. "-J" is recommended for HART communication.

*2: HART protocol revision for the device and HART configuration tool HART7 communication is supported by FieldMate R2.02 or later.

HART protocol revision and availability

| | Protocol revision supported by HART configuration tool | |
|------------------|--|-----------|
| | 5 | 7 |
| DY or DYA HART 5 | Available | Available |
| DY or DYA HART 7 | Not Available | Available |

Note: Protocol revision supported by HART configuration tool must be the same or higher than that of the digital YEWFLOW.

Functions:

Damping Time Constant:

0 to 99 Sec (63% response time)

Note: Delay time is 0.5 Sec.

Analog output circuit time constant is 0.3 Sec.

Pulse Output Function*:

Pulse output is selected from scaled pulse, unscaled pulse, frequency (number of pulses output per second at 100% of output).

Pulse frequency: Max 10 kHz

Duty cycles: Approx.50% (1:2 to 2:1)

Self-diagnostics and Alarm Output*:

In case alarm (over range output signal, EEPROM error, vibration noise, abnormal flow such as clogging, bubble) occurs, an alarm signal is output and indicated.

The alarm signal output goes from close(ON) to open(OFF) during alarming.

Analog Output Function:

Analog output is selected from flowrate and temperature value when option code /MV is selected.

Status Output Function*:

Flow Switch:

In case flow rate decreases under the flow set value, a status signal is output.

Status signal output mode can reverse (ON/OFF).

Data Security During Power Failure:

Data (parameter, totalizer value, etc) storage by EEPROM. No back-up battery required.

Correction:

Instrument Error Correction:

Vortex flowmeter instrument errors can be corrected by segment approximations.

Reynolds Number Correction:

Output error at Reynolds number 20000 or less is corrected by using five-break-point line-segment approximation.

Gas Expansion Correction:

When measuring a compressibility gas and steam, this expansion factor is useful to correct the error at high velocity of flow (35m/s or more).

Down-scale or Up-scale burn out.

In case a CPU or EEPROM failure occurs, flow meter output the signal of Up-scale (21.6 mA or more).

Up-scale or Down-scale (3.6 mA or less) is user-selectable through the fail mode alarm jumper.

Indicator:

Flow rate (% or engineering units) or temperature value and totalizer can be indicated simultaneously.

Short message for self diagnostics indicated. Local parameter setting can be operated by key switches.

In mounting direction, the right and left 90° is rotatable.

EMC Conformity Standards:

EN 61326-1 Class A, Table 2 (For use in industrial locations), EN 61326-2-3

- Performance Specification during immunity test

Flowrate output: Output fluctuation within measurement accuracy

Temperature output: Output fluctuation within ±1.0 °C

Note1: This instrument is a Class A product, and it is designed for use in the industrial environment. Please use this instrument in the industrial environment only.

Note2: Use the metal conduit for the remote cable.

CE marking:

CE marking is attached for non-Explosion protected type(Note 1) and ATEX Explosion protected type.

The product which is attached CE marking is in conformity with the statutory requirements of the applicable EU Directives.

Note 1: /HX2 (Anti-Corrosion Version I) of DY150 is not PED compliant. CE marking is not attached.

EU RoHS Directive:

EN 50581

Morocco Conformity Mark 

This conformity mark indicates that the product complies with Moroccan requirements.

Pressure Equipment Directive:

Type of equipment: Pressure accessory – Piping

Type of fluid: liquid and gas

Group of fluid: 1 and 2

Module: H

| MODEL | DN (mm)* | PS* | | PS-DN | | CATEGORY** |
|-------|----------|-------|-------|----------|----------|-------------------------------------|
| | | (bar) | (MPa) | (bar-mm) | (MPa-mm) | |
| DY015 | 15 | 420 | 42 | 6300 | 630 | Sound Engineering Practice (SEP)*** |
| DY025 | 25 | 420 | 42 | 10500 | 1050 | Sound Engineering Practice (SEP)*** |
| DY040 | 40 | 420 | 42 | 16800 | 1680 | II**** |
| DY050 | 50 | 420 | 42 | 21000 | 2100 | II**** |
| DY080 | 80 | 420 | 42 | 33600 | 3360 | II**** |
| DY100 | 100 | 420 | 42 | 42000 | 4200 | II**** |
| DY150 | 150 | 420 | 42 | 63000 | 6300 | III |
| DY200 | 200 | 420 | 42 | 84000 | 8400 | III |
| DY250 | 250 | 420 | 42 | 105000 | 10500 | III |
| DY300 | 300 | 420 | 42 | 126000 | 12600 | III |
| DY400 | 400 | 250 | 25 | 100000 | 10000 | III |

* PS: Maximum allowable pressure for Flow tube, DN: Nominal size

** Table 6 covered by ANNEXII of Directive 2014/68/EU

*** Article 4, paragraph 3 of Directive 2014/68/EU

**** MODELS classified in CATEGORY II shall not be used for unstable gases of Group 1.

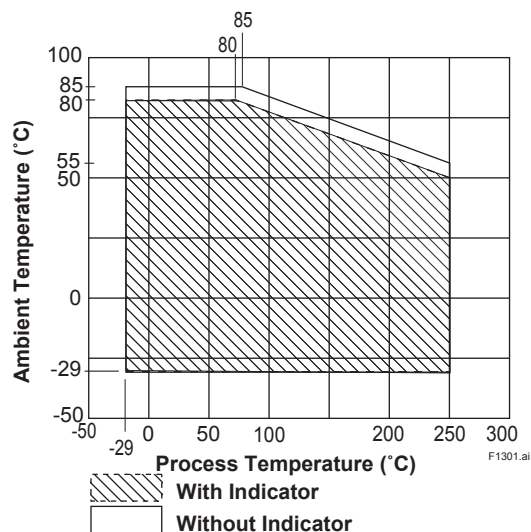

Figure 13.1 Ambient Temperature limit (Integral Type)

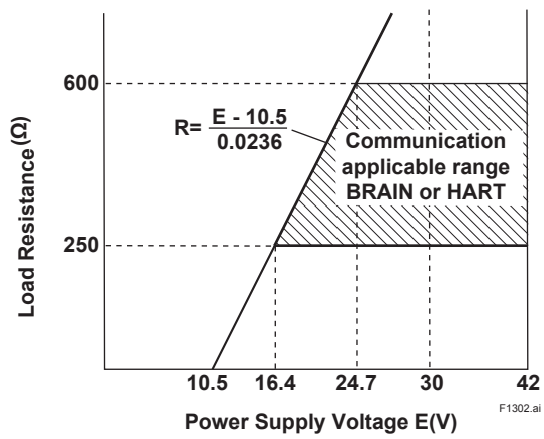

Figure 13.2 Relationship Between Power Supply and Load Resistance

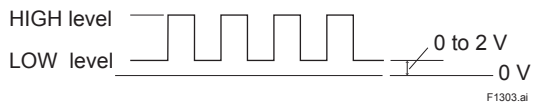

Figure 13.3 High and low level (Pulse output)

13.2 Model And Suffix Codes

DY Vortex Flowmeter (Integral Type, Remote Type detector)

| Model | Suffix Codes | Description |
|--|-------------------------------|---|
| DY015 | | Size 15 mm (1/2 inch) |
| DY025 | | Size 25 mm (1 inch) |
| DY040 | | Size 40 mm (1-1/2 inch) |
| DY050 | | Size 50 mm (2 inch) |
| DY080 | | Size 80 mm (3 inch) |
| DY100 | | Size 100 mm (4 inch) |
| DY150 | | Size 150 mm (6 inch) |
| DY200 | | Size 200 mm (8 inch) |
| DY250 | | Size 250 mm (10 inch) |
| DY300 | | Size 300 mm (12 inch) |
| DY400 | | Size 400 mm (16 inch) |
| Output Signal /Communication | -D | 4 to 20 mA DC, Pulse, BRAIN Communication |
| | -E | 4 to 20 mA DC, Pulse, HART Communication *1 |
| | -J | 4 to 20 mA DC, Pulse, HART 5/HART 7 Communication *2 |
| | -F | Digital communication (FOUNDATION Fieldbus protocol) *3 |
| | -N | Remote type detector |
| Body Material *6, *7 | A | SCS14 A *4 |
| | B | CF8M *5 |
| | X | Others |
| Shedder bar Material *6, *7 | L | Duplex Stainless Steel |
| | B | Stainless Steel |
| | E | Duplex Stainless Steel (for TIIS Approval) |
| | X | Others |
| Process Connection *8, *15 RF: Raised Face SF: Smooth Finish RJ: Ring Joint R13: DIN 2513 Type R13 | AJ1 | JIS 10 K Wafer |
| | AJ2 | JIS 20 K Wafer |
| | AJ4 | JIS 40 K Wafer |
| | AA1 | ANSI Class 150 Wafer |
| | AA2 | ANSI Class 300 Wafer |
| | AA4 | ANSI Class 600 Wafer |
| | AD1 | DIN PN10 Wafer |
| | AD2 | DIN PN16 Wafer |
| | AD3 | DIN PN25 Wafer |
| | AD4 | DIN PN40 Wafer |
| | BJ1 | JIS 10K Flange(RF) |
| | BJ2 | JIS 20K Flange(RF) |
| | BJ4 | JIS 40K Flange(RF) |
| | BA1 | ANSI Class 150 Flange(RF) |
| | BA2 | ANSI Class 300 Flange(RF) |
| | BA4 | ANSI Class 600 Flange(RF) |
| | BA5 | ANSI Class 900 Flange(RF) |
| | BA6 | ANSI Class1500 Flange(RF) *17 |
| | BS1 | ANSI Class 150 Flange(RF, SF) |
| | BS2 | ANSI Class 300 Flange(RF, SF) |
| | BS4 | ANSI Class 600 Flange(RF, SF) |
| | BS5 | ANSI Class 900 Flange(RF, SF) |
| | BD1 | DIN PN10 Flange(RF) |
| | BD2 | DIN PN16 Flange(RF) |
| | BD3 | DIN PN25 Flange(RF) |
| | BD4 | DIN PN40 Flange(RF) |
| | CA4 | ANSI Class 600 Flange(RJ) |
| | CA5 | ANSI Class 900 Flange(RJ) |
| CA6 | ANSI Class1500 Flange(RJ) *17 | |
| FD1 | DIN PN10 Flange(R13) | |
| FD2 | DIN PN16 Flange(R13) | |
| FD3 | DIN PN25 Flange(R13) | |
| FD4 | DIN PN40 Flange(R13) | |
| Electrical Connection *9 | -0 | JIS G 1/2 Female |
| | -2 | ANSI 1/2 NPT Female *10 |
| | -4 | ISO M201.5 Female |
| Indicator *11 | D | With Indicator |
| | N | None Indicator, Remote type detector |
| Options | /□ | Read Option Specifications |

- *1: Output signal code '-E': HART 5. (Output signal code '-J' is recommended for HART communication.)
- *2: Output signal code '-J': HART 5 or HART 7 selectable. Specify HART 5 or HART 7 when ordering.
- *3: For FOUNDATION Fieldbus protocol, read GS 01F06F01-01EN. For Fieldbus communication type, there are not setting keys on the display board.
- *4: In case of A (SCS14A), the process connection is available for JIS (AJ□, BJ□)
- *5: In case of B (CF8M), the process connection is available for ANSI (AA□, BA□, BS□, CA□) and DIN (AD□, BD□, FD□). In case of process connection code BA6 or CA6, body material is F316.
- *6: Read Table 13.1.
- *7: Users must consider the characteristics of selected wetted parts material and the influence of process fluids. The use of inappropriate materials can result in the leakage of corrosive process fluids and cause injury to personnel and/or damage to plant facilities. It is also possible that the instrument itself can be damaged and that fragments from the instrument can contaminate the user's process fluids.
Be very careful with highly corrosive process fluids such as hydrochloric acid, sulfuric acid, hydrogen sulfide, sodium hypochlorite, and hightemperature steam (+150°C [+302°F] or above). Contact Yokogawa for detailed information of the wetted parts material.
- *8: Read Table 13.2.
- *9: In case of an explosion protected type, it depends for an electrical connection on the kind of an explosion protected type. Read Section 13.6 "Option Specifications (For Explosion Protected Type)".
- *10: In case of /FF1 or /CF1, /CF11, /KF2, /KS2, /SF2, /SS2 the screw length is deeper than ANSI standard for 0.5 to 2 threads.
- *11: Indicator is not available for remote type detector.
- *12: DY A-□□□/MV and DY □□□-N***/MV should be combined.
- *13: One set of end finish part is attached.
- *14: DY C Signal Cable can be used up to 30m. When you divide the cable below 30m, select the Cable End code [-0].
- *15: In case of the process connection FD□, the Option code /LT is not available.
- *16: An exclusive User's Manual might be attached for products whose suffix code or optional codes contain code "Z". Read it along with their standard manual.
- *17: In case of BA6 or CA6, combination with the option code /R1 is mandatory(DY025/R1 to DY150/R1), and it is not available to combine with option code /HT, /LT and /MV.

DYA Remote Type Vortex Flow Converter

| Model | Suffix Codes | Description |
|------------------------------|--------------|---|
| DYA | | Vortex Flowmeter Converter (Remote Type) |
| Output Signal /Communication | -D | 4 to 20 mA DC, Pulse BRAIN Communication |
| | -E | 4 to 20 mA DC, Pulse HART Communication *1 |
| | -J | 4 to 20 mA DC, Pulse HART 5/HART 7 Communication *2 |
| | -F | Digital communication (FOUNDATION Fieldbus protocol) *3 |
| Electrical Connection *9 | 0 | JIS G 1/2 Female |
| | 2 | ANSI 1/2 NPT Female *10 |
| | 4 | ISO M20 ×1.5 Female |
| Indicator | D | With Indicator |
| | N | None Indicator |
| Options | /□ /MV | Read Option Specifications Multi-Variable Type *12 |

DYC Remote Type Signal Cable

| Model | Suffix Codes | Description |
|------------------|---------------------|------------------------------|
| DYC | | Signal Cable |
| Cable End | -0 | Without End finish *13 |
| | -1 | With End finish |
| Cable Length *14 | -05 | 5 m |
| | -10 | 10 m |
| | -15 | 15 m |
| | -20 | 20 m |
| | -25 | 25 m |
| | -30 | 30 m |
| | -35 | 35 m |
| | -40 | 40 m |
| | -45 | 45 m |
| | -50 | 50 m |
| | -55 | 55 m |
| | -60 | 60 m |
| | -65 | 65 m |
| | -70 | 70 m |
| -75 | 75 m | |
| -80 | 80 m | |
| -85 | 85 m | |
| -90 | 90 m | |
| -95 | 95 m | |
| Options | /C1 | Cable End Finish Parts 1 set |
| | /C2 | 2 set |
| | /C3 | 3 set |
| | /C4 | 4 set |
| | /C5 | 5 set |
| | /C6 | 6 set |
| | /C7 | 7 set |
| /C8 | 8 set | |
| /C9 | 9 set | |
| /MV | Multi-Variable Type | |

Table 13.1 Body, Shedder Bar and Gasket Material

Body Material

| Model Code | | | Standard (Note1) | Anti-Corrosion Version I (/HX1, /HX2, /HX3) (Note2) | Anti-Corrosion Version II (/HY) (Note2) | High Process Temperature Version (/HT) (Note2) | Cryogenic Version (/LT) (Note2) | NACE Material (/NC) |
|---------------------------|----------|----------|--------------------------------|---|---|--|---------------------------------|---------------------|
| Reduced bore type (Note3) | | | | | | | | |
| DY015 | DY025/R1 | DY040/R2 | A SCS14A or B CF8M | X (Note2) CW-12MW | X SCS14A CF8M (Note2) | X SCS14A CF8M (Note2) | X 1.4308 (Note2) | X CF8M |
| DY025 | DY040/R1 | DY050/R2 | | | | | | |
| DY040 | DY050/R1 | DY080/R2 | | | | | | |
| DY050 | DY080/R1 | DY100/R2 | | | | | | |
| DY080 | DY100/R1 | DY150/R2 | | | | | | |
| DY100 | DY150/R1 | DY200/R2 | | | | | | |
| DY150 | DY200/R1 | — | | | | | | |
| DY200 | — | — | | | | | | |
| DY250 | — | — | | | | | | |
| DY300 | — | — | | | | | | |
| DY400 | — | — | | | | | | |

- (Note1) In case of the suffix code of the body material is [A], the code of the process connection is for one of AJ□, BJ□ or BP□. In case of the code [B], process connection code is for one of AA□, BA□, BS□, CA□, AD□, BD□ or FD□. In case of process connection code BA6 or CA6, body material is F316.
- (Note2) In cases of option code /HX1, /HX2, /HX3, /HY, /HT, /LT or /NC, select [X] for both body material code and select shedder bar material code in accordance with the shedder bar material chart.
- (Note3) Reduced bore type is Flange type only. It cannot be combined with the option code /R1, /R2 and /LT.

Shedder Bar Material

| Model Code | | | Standard | | Anti-Corrosion Version I (/HX1, /HX2, /HX3) (Note1,2) | Anti-corrosion version II (/HY) (Note1,2) | High Process Temperature Version (/HT) (Note1,2) | Cryogenic Version (/LT) (Note1,2) | NACE Material (/NC) (Note1,2) |
|---------------------------|----------|--|-------------|-------------|---|---|--|-----------------------------------|--|
| Reduced bore type (Note3) | | TIIS Flame proof approval (/JF3) (Note2) | | | | | | | |
| DY015 | DY025/R1 | DY040/R2 | L S31803 | E S31803 | X N10276 | X N10276 | — | X N10276 | X N10276 |
| DY025 | DY040/R1 | DY050/R2 | L 1.4517 | E 1.4517 | X (Note2) CW-12MW | X CW-12MW | X CW-12MW | X CW-12MW | X CW-12MW |
| DY040 | DY050/R1 | DY080/R2 | | | | | | | |
| DY050 | DY080/R1 | DY100/R2 | | | | | | | |
| DY080 | DY100/R1 | DY150/R2 | | | | | | | |
| DY100 | DY150/R1 | DY200/R2 | | | | | | | |
| DY150 | DY200/R1 | — | L 1.4517 | E 1.4517 | — | — | X CW-12MW or B CF8M (Note4, 6) | — | X CW-12MW or B CF8M (Note4) |
| DY200 | — | — | | | | | | | |
| DY250 | — | — | | | | | | | |
| DY300 | — | — | | | | | | | |
| DY400 | — | — | B CF8M | B CF8M | — | — | B CF8M (Note5, 6) | — | — |

- (Note1) Select body code [X] for /HX1, /HX2, /HX3, /HY, /HT, /LT and /NC. Available to combine with TIIS Flame proof type /JF3 or Multi-Variable type /MV.
- (Note2) The shedder bar code [E] is for TIIS Flame proof type /JF3 only. Select shedder bar code [X] for DY015 to DY200 when you combine TIIS Flame proof type /JF3 with /HX1, /HX2, /HX3, /HY, /HT, /LT or /NC.
- (Note3) Reduced bore type is Flange type only. It cannot be combined with the option code /R1, /R2 and /LT.
- (Note4) Shedder bar code [X] or [B] is selectable for DY150/HT, DY150/NC, DY200/HT and DY200/NC.
- (Note5) Select shedder bar code only [B] for DY250/HT to DY400/HT.
- (Note6) In case of shedder bar code [B], combination of High Process Temperature Version /HT and TIIS Flame proof type /JF3 is not available.

Gasket Material (assemble to shedder bar)

| Model Code | | | Standard | Anti-Corrosion Version I (/HX1, /HX2, /HX3) | Anti-corrosion Version II (/HY) | High Process Temperature Version (/HT) | Cryogenic Version (/LT) | NACE Material (/NC) | Stainless steel plated with silver gasket (/SPG) (Note 2) |
|---------------------------|----------|----------|--|---|--|---|--|--|---|
| Reduced bore type (Note1) | | | | | | | | | |
| DY015 | DY025/R1 | DY040/R2 | SUS316 stainless steel with PTFE coating | N10276 with PTFE coating | SUS316 stainless steel with PTFE coating | SUS316 stainless steel plated with silver | SUS316 stainless steel with PTFE coating | SUS316 stainless steel with PTFE coating | SUS316 stainless steel plated with silver |
| DY025 | DY040/R1 | DY050/R2 | | | | | | | |
| DY040 | DY050/R1 | DY080/R2 | | | | | | | |
| DY050 | DY080/R1 | DY100/R2 | | | | | | | |
| DY080 | DY100/R1 | DY150/R2 | | | | | | | |
| DY100 | DY150/R1 | DY200/R2 | | | | | | | |
| DY150 | DY200/R1 | — | | | | | | | |
| DY200 | — | — | | | | | | | |
| DY250 | — | — | | | | | | | |
| DY300 | — | — | | | | | | | |
| DY400 | — | — | | | | | | | |

(Note1) Reduced bore type is Flange type only. It cannot be combined with the option code /R1, /R2 and /LT.

(Note2) Option code /SPG is not available for /HT, /LT, /HX1, /HX2, /HX3.

Table 13.2 Flowmeter Selection Guide

| Process Connection | Wafer | | | Flange (Raised Face) | | | | Flange (Ring Joint) | | | Flange (Raised Face, Smooth Finish) | | | | Flange (DIN 2513 Type R13) | | |
|--------------------|-------------|----------------|--------------------------|----------------------|----------------|----------------------|--------------------------|------------------------|---------------|-------------------|-------------------------------------|---------------|-------------------|----------------------|----------------------------|----------------|---|
| | Suffix Code | Model Code | | Suffix Code | Model Code | | | Suffix Code | Model Code | | Suffix Code | Model Code | | Suffix Code | Model Code | | |
| | | Standard Type | Anti-Corrosion Version I | | Standard Type | Reduced Bore Type | Anti-Corrosion Version I | | Standard Type | Reduced Bore Type | | Standard Type | Reduced Bore Type | | | Standard Type | |
| JIS 10K | AJ1 | DY015 to DY100 | DY015/HX1 to DY100/HX1 | BJ1 | DY015 to DY400 | DY025/R1 to DY200/R1 | DY040/R2 to DY200/R2 | DY015/HX2 to DY100/HX2 | — | — | — | — | — | — | — | — | |
| JIS 20K | AJ2 | DY015 to DY100 | DY015/HX1 to DY100/HX1 | BJ2 | DY015 to DY400 | DY025/R1 to DY200/R1 | DY040/R2 to DY200/R2 | DY015/HX3 to DY100/HX3 | — | — | — | — | — | — | — | — | |
| JIS 40K | AJ4 | DY015 to DY100 | DY015/HX1 to DY100/HX1 | BJ4 | DY015 to DY150 | — | — | — | — | — | — | — | — | — | — | — | |
| JPI Class 150 | AP1 | DY015 to DY100 | — | BP1 | DY015 to DY400 | DY025/R1 to DY200/R1 | DY040/R2 to DY200/R2 | — | — | — | — | — | — | — | — | — | |
| JPI Class 300 | AP2 | DY015 to DY100 | — | BP2 | DY015 to DY400 | DY025/R1 to DY200/R1 | DY040/R2 to DY200/R2 | — | — | — | — | — | — | — | — | — | |
| JPI Class 600 | AP4 | DY015 to DY100 | — | BP4 | DY015 to DY150 | — | — | — | — | — | — | — | — | — | — | — | |
| ANSI Class 150 | AA1 | DY015 to DY100 | DY015/HX1 to DY100/HX1 | BA1 | DY015 to DY400 | DY025/R1 to DY200/R1 | DY040/R2 to DY200/R2 | DY015/HX2 to DY150/HX2 | — | — | — | BS1 | DY015 to DY400 | DY025/R1 to DY200/R1 | DY040/R2 to DY200/R2 | — | — |
| ANSI Class 300 | AA2 | DY015 to DY100 | DY015/HX1 to DY100/HX1 | BA2 | DY015 to DY400 | DY025/R1 to DY200/R1 | DY040/R2 to DY200/R2 | DY015/HX3 to DY100/HX3 | — | — | — | BS2 | DY015 to DY400 | DY025/R1 to DY200/R1 | DY040/R2 to DY200/R2 | — | — |
| ANSI Class 600 | AA4 | DY015 to DY100 | DY015/HX1 to DY100/HX1 | BA4 | DY015 to DY200 | — | — | — | CA4 | DY015 to DY200 | — | BS4 | DY015 to DY200 | — | — | — | |
| ANSI Class 900 | — | — | — | BA5 | DY015 to DY200 | — | — | — | CA5 | DY015 to DY200 | — | BS5 | DY015 to DY200 | — | — | — | |
| ANSI Class 1500 | — | — | — | BA6 | — | DY025/R1 to DY150/R1 | — | — | CA6 | — | DY025/R1 to DY150/R1 | — | — | — | — | — | |
| DIN PN10 | AD1 | DY015 to DY100 | DY015/HX1 to DY100/HX1 | BD1 | DY015 to DY200 | — | — | — | — | — | — | — | — | — | — | DY015 to DY200 | |
| DIN PN16 | AD2 | DY015 to DY100 | DY015/HX1 to DY100/HX1 | BD2 | DY015 to DY200 | — | — | — | — | — | — | — | — | — | — | DY015 to DY200 | |
| DIN PN25 | AD3 | DY015 to DY100 | DY015/HX1 to DY100/HX1 | BD3 | DY015 to DY200 | — | — | — | — | — | — | — | — | — | — | DY015 to DY200 | |
| DIN PN40 | AD4 | DY015 to DY100 | DY015/HX1 to DY100/HX1 | BD4 | DY015 to DY200 | — | — | — | — | — | — | — | — | — | — | DY015 to DY200 | |

(Note)

- ANSI standardized types are worked by serration finishing except the Smooth Finish type.
- The Smooth Finish type is shipped without serration finishing.
- Read Subsection 13.3.2 "Option Reduced Bore Type (/R1, /R2)", when you select reduced bore type (Option code /R1, /R2).

13.3 Option Specifications

| Item | Specification | Applicable Model | Code | |
|---|---|--|--|-----|
| Multi-Variable Type (Note 5) | Build in temperature sensor (Pt 1000) in vortex shedder bar. | DY / DYA | MV | |
| Reduced bore type (Note 8) (Note 12) | Integrated and welded construction with concentric reduced bore piping. R1: Detector size (B) is one meter body size down of digitalYEWFLO to flange pipe size (A). | DY | R1 | |
| | R2: Detector size (B) is two meter body size down of digitalYEWFLO to flange pipe size (A). | | R2 | |
| Stainless Steel Tag Plate (Note 1) | SUS304 tag plate, hung on the case. | DY / DYA | SCT | |
| Stainless Steel Bolt & Nut Assembly | SUS304 bolt/nut assembly. Used when a wafer type is installed. | DY Wafer Type | BL | |
| Paint Color Change | Only for the covers: Read Table 13.3 | DY / DYA | Read Table 13.3 | |
| Hydrostatic / Pneumatic Test Certificate | Test pressure value is in accordance with Table 13.4 Test time: 10 minutes. Available for the Standard type. Test medium: Air, Nitrogen or Water. | DY | T01 (Note 11) | |
| Hydrostatic Test Certificate | Test pressure value is in accordance with Table 13.4 Test time: 10 minutes. Available for the Standard type. Test medium: Water. | DY | T02 (Note 11) | |
| Degrease Treatment (Note 2) | Degrease cleansing treatment. | DY | K1 | |
| Epoxy Coating | Epoxy coating for case and cover. | DY / DYA | X1 | |
| Piling up coating of epoxy and polyurethane | Epoxy and Polyurethane coating for the purpose of corrosion - proof improvement; salt damage, alkali, climate and acidity | DY / DYA | X2 | |
| High Process Temperature Version | This specification temperature is from -29 to +450 °C Read Table 13.1, Figure 13.4. Read Table 13.5 for minimum velocity. Read Note 5 for the combination of High process temperature version (/HT) and Multi-variable type (/MV). Combination with Anti-Corrosion version I (/HX1, /HX2, /HX3) is not available. | DY***-N | HT | |
| Cryogenic Version (Note 7) | This specification temperature is from -196 to +100 °C Read Table 13.1, Figure 13.5. Combination with Reduced bore type(/R1,/R2), Anti-corrosion version I (/HX1, /HX2, /HX3) is not available. | DY***-N | LT | |
| Stainless steel plated with silver gasket | Gasket material assembling to the shedder bar: SUS316 stainless steel plated with silver (Read Table 13.1) | DY | SPG | |
| Stainless Steel Bracket for Remote Converter (DYA) | The bracket material for remote converter type (DYA) is SUS304. | DYA | SB | |
| Lightning Protector | There is an arrester inside converter for power supply line. Maximum power supply voltage: 30VDC | DY Integral Type / DYA | A | |
| NACE Material (Note 10) | Read Table 13.1. | DY | NC | |
| Compliance with NAMUR (Note 6) | Compliance with NAMUR43. Current signal for measurement is 4mA up to 20.5mA. Set output 3.6mA or less when burn-out occurred. | DY / DYA | NM | |
| Anti-corrosion Version I (Note13) | Read Table 1 for wetted parts material. Process pressure limit : -0.1MPa to flange rating * *: Flange rating is in according with standard material (SCS14A, CF8M) Combination with High process temperature version(/HT), Cryogenic Version(/LT), Reduced bore type(/R1,/R2) is not available. DY150 is not PED compliant. Materials of construction meet NACE material recommendations per MR0175 without /NC. | DY | HX1 HX2 HX3 (Read Table 13.2) | |
| Anti-corrosion Version II | Read Table 1 for wetted parts material. DY150/R1, DY150/R2, and DY200/R2 are not available. | DY | HY | |
| Converter Installing Direction 180° Change (Note4) | Converter installing direction 180° change inversely when shipped. | DY | CRC | |
| Down-scale burn-out in CPU or EEPROM failure (Note 3) | Set output 3.6mA or less when burn-out occurred. | DY Integral Type / DYA | C1 | |
| Stainless steel housing (Note 9) | Converter housing, case and cover material: SCS14A or CF8M stainless steel castings. (equivalent to SUS316) | DY***-N / DYA | E1 | |
| Flameproof Packing Adapter | Power source connection port and signal cable (remote type) connection port. JIS G1/2 female thread. Other cable shape: ø 8 to ø 12. /G11: One piece, /G12: Two pieces. | DY / JF3 | G11 | |
| | | DYA / JF3 | G12 | |
| Calibration Certificate (Note 14) | Level 2 Declaration and Calibration Equipment List | DY-D, -E, -J, -N DYA-D, -E, -J | L2 | |
| | Level 3 Declaration and Primary Standard List | | L3 | |
| | Level 4 Declaration and YOKOGAWA Measuring | | L4 | |
| Material certificates: Mill sheets | Item to be specified | DY | 1. Meterbody | |
| | | | 1. Meterbody, 2. Shedder bar | |
| | | | 1. Meterbody, 2. Shedder bar, 3. Bottom plug | |
| | | | 1. Meterbody, 2. Shedder bar, 3. Bottom plug, 4. Welding rod | |
| Material certificates: 3.1 | Item to be specified | DY | 3.1 certificate to be attached according to EN10204. | |
| | | | 1. Meterbody | |
| | | | 1. Meterbody, 2. Shedder bar | |
| | | | 1. Meterbody, 2. Shedder bar, 3. Bottom plug | |
| | | | 1. Meterbody, 2. Shedder bar, 3. Bottom plug, 4. Welding rod | |
| PMI test certificate | Positive Material Identification certificate to be attached for the main 3 chemical components of specified materials. Each certificate to be attached. | | DY | |
| | Item to be specified | 1. Meterbody | | PM1 |
| | | 1. Meterbody, 2. Shedder bar | | PM2 |
| ASME welding documents submission (Note 10) | • Welder/Welding Operator Performance Qualification (or Welder Qualification Record) • Welding Procedure Specification (WPS) • Procedure Qualification Record (PQR) | | DY 2. is for DY250 to DY400. | |
| | Item to be specified | 1. Welded portion for the bottom plug 2. Welded portion for the flange in case of the welding construction | | WP |
| Dye Penetrant test certificate | Dye Penetrant test certificate for the welded portion to be attached. Each certificate to be attached. | | DY 2. is for DY250 to DY400. | |
| | Item to be specified | 1. Welded portion for the bottom plug 2. Welded portion for the flange in case of the welding construction Criterion: ASME B31.1 | | PT |

(Note 1) Up to 30 alphanumeric characters can be engraved on the stainless tag plate. Capital/small letters are available for BRAIN communication “-D” and FOUNDATION Fieldbus “-F”. Only capital letters are available for HART communication “-E” or “-J”.

(Note 2) There is a case that calibration water should stay in the meter tube. So this is not degrease treatment in the strict sense.

- (Note 3) The output is set 3.6mA or less (Standard type is set 21.6mA or more at shipping).
- (Note 4) The electrical connection turn to a downstream side.
- (Note 5) Read Subsection 13.3.1 "Option Multi-Variable (Built-In Temperature Sensor) Type (/MV)"
In case of Remote type detector (DY***-N), select "/MV" both DY and DYA.
- (Note 6) /NM can not combine with Remote type (DY***-N).
- (Note 7) ATEX Flameproof Approval /KF2 and IECEx Flameproof Approval /SF2 are not Available.
- (Note 8) Combination with Cryogenic version /LT, Anti-Corrosion version I /HX1, /HX2, /HX3 is not available.
 - High process temperature version /HT and Multi-variable type /MV for DY025/R1 and DY040/R2 is not available.
 - Flange type only and available process connections are JIS10k, 20k (BJ1, BJ2) and ANSI class 150, 300 (BA1, BA2, BS1, BS2).
 - Model Code (A) means "DY***-" nominal size.
- (Note 9) • Applicable for Option code /FF1, /FS1, /KF2, /KS2, /SF2 and /SS2.
• Not applicable for Option code /P1, /P2, /P7, /X1, /X2, /HT, /LT, /SB /JF3, /CF1, /CS1, /CF11 and /CS11.
• The materials of exterior parts, name plate, screw, bolts on the stainless steel housing and bracket, u-bolt, nuts for DYA/E1 and tag plate for /E1/SCT are SUS316 or SUS316L.
- (Note 10) The wetted parts materials conform to NACE material recommendations per MR0175. Please refer to the standards for details.
Materials of construction of /HX1, /HX2, /HX3 also meet NACE material recommendations per MR0175 without /NC.
NACE Material /NC can not combine with ASME welding documents submission /WP.
- (Note 11) /T01 and /T02 can be selected only one code either.
- (Note 12) Read Subsection 13.3.2 "Option Reduced Bore Type (/R1, /R2)"
- (Note 13) • Available process connections of flange type are JIS10K, 20K (BJ1, BJ2) and ANSI class 150, 300 (BA1, BA2).
• Available process connection of DY150 are ANSI class 150 (BA1).
• Available process connections of wafer type are JIS 10K, 20K, 40K (AJ1, AJ2, AJ4) and ANSI class 150, 300, 600 (AA1, AA2, AA4) and DIN PN10, PN16, PN25, PN40(AD1, AD2, AD3, AD4).
- (Note 14) Single calibration of converter for FOUNDATION Fieldbus communication type (DYA-F) does not publish the calibration certificate because it is the digital communication.

Table 13.3 Paint Color and Codes

| Codes | Munsell Renotation Codes | Color |
|-------|--------------------------|-----------------|
| P1 | N1.5 equivalent | Black |
| P2 | 7.5BG4/1.5 equivalent | Shade green |
| P7 | ————— | Metallic silver |

Table 13.4 Test Pressure Value

| Flange Rating | Pressure |
|-------------------------|----------|
| JIS 10 K | 2.1 MPa |
| JIS 20 K | 5.0 MPa |
| JIS 40 K | 10.0 MPa |
| ANSI Class 150 | 2.9 MPa |
| ANSI Class 300 | 7.5 MPa |
| ANSI Class 600 | 14.9 MPa |
| ANSI Class 900 | 22.4 MPa |
| ANSI Class 1500 (Note1) | 37.3 MPa |
| DIN PN 10 | 1.5 MPa |
| DIN PN 16 | 2.4 MPa |
| DIN PN 25 | 3.8 MPa |
| DIN PN 40 | 5.9 MPa |

(Note1) In case of DY040-□XX□A6-□□/HY or /NC, test pressure value is 29.8MPa.

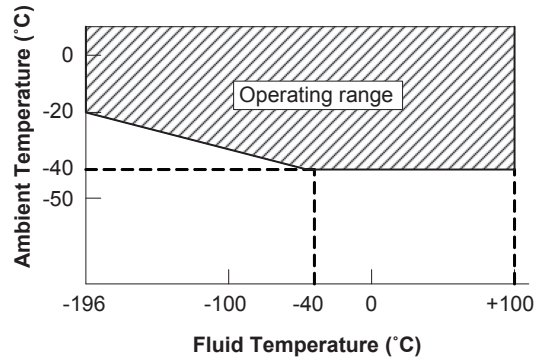

Figure 13.5 Fluid Temperature Range of Cryogenic Version

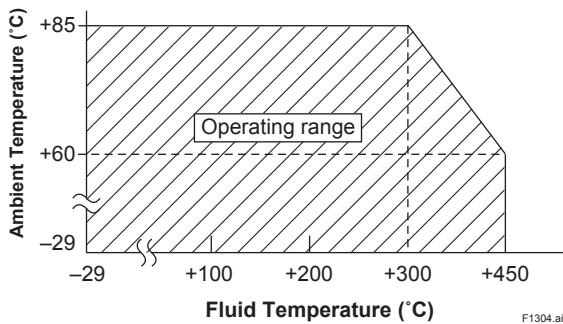

Figure 13.4 Fluid Temperature Range of High Process Temperature Version

13.3.1 Option Multi-Variable (Built-In Temperature Sensor) Type (/MV)

This options is the same as standard specification except the following items.

| | | | |
|-------------------------------------|--|--|--|
| Model Code | | DY025 to DY100 : Wafer type DY025 to DY200 : Flange type | |
| Option Code (Note1) | | Multi-Variable (Built-in Temperature sensor) Type (Option Code: /MV) | High Process Temperature Version Multi-Variable Type (Option Code: /HT/MV) |
| Function (Note2) | Temperature indication / output | Temperature Range | -29 to +250°C |
| | Saturated steam Mass flowrate (Note3) | Calculation Temperature Range | +100 to +250°C |
| | Superheated steam Mass flowrate (Note4) | | +100 to +250°C |
| | Gas Volume flowrate (Note5) | | -29 to +250°C |
| | Liquid Mass flowrate (Note6) | | -29 to +250°C |
| Temperature Response (50% Response) | | 60 sec (Churning Underwater) | |
| Output | Analog Output | Select from Flow Rate or Temperature (Note7) | |
| | Pulse Output | Flow Rate: Same as Standard Type | |
| | Alarm Output | Alarm Output same as Standard Type and Temperature Sensor Error, etc. | |
| | Status Output | Flow Switch (Flow Rate): Same as Standard Type | |
| Display | Upper | Select from Flow Rate (% , Engineering Unit) or Temperature (%) (Note8) | |
| | Lower | Select from Total Rate or Temperature (°C, °F) (Note9) | |
| Remote Type | | Select Vortex Flow Converter DYA-***MV and Signal Cable DYC-***MV (Note10) | |

(Note1) Multi-Variable Type (/MV) can not be combined with Cryogenic Version (/LT). Read the "DETAILED ACCURACY" for accuracy.

(Note2) Temperature measurement may be affected by installation conditions, such as thermal insulation of piping or the temperature distribution of the fluid. Read section 3.2 "Piping Precautions" for thermal insulation of piping. When measuring mass flow of saturated steam, superheated steam thermal insulation of piping may be required.

(Note3) Mass flow rate is calculated from density calculated with density at the measured temperature derived by the built-in saturated steam table.

(Note4) Mass flow rate is calculated with the density at the measured temperature derived by the built-in steam table. For mass flow calculation of superheated steam, operating pressure is used as constant value.

(Note5) Volumetric flow rate is calculated by temperature/pressure compensation. For volumetric flow calculation of gas, operating pressure and pressure at standard/normal condition are used.

(Note6) Mass flow rate is calculated with density compensated by the secondary formula of measured temperature. Operating density is used as a base density and the 1st and 2nd coefficients have to be set.

(Note7) The factory setting is the flow rate output. When the temperature output is required, it is necessary to change the parameter.

(Note8) In case of indicating the temperature %, the display indicate not only "%" but also "t". ("t" means temperature).

(Note9) "Total" is set for shipping when the total rate is specified in sizing data.

(Note10) In case of remote type, option code (/MV) is necessary for both Vortex Flow Converter (DYA) and Signal Cable (DYC). To correct the temperature error due to signal cable length, parameter setting of the signal cable length to Vortex Flow Converter (DYA) is required.

13.3.2 Option Reduced Bore Type (/R1, /R2)

This option is the same as standard specification except the following items.

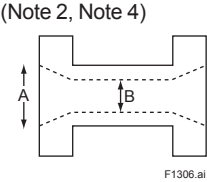
| | | Reduced Bore Type (Option: /R1, /R2) (Note1) | | | |
|---|--------------------|--|-----------------------------------|-----------------------------------|--|
|  <p>(Note 2, Note 4)</p> | Model Code | Flange piping size (A) | R1 Detector size (inner dia.) (B) | R2 Detector size (inner dia.) (B) | [Pressure Loss] R1: about 15% increases to standard type. R2: about 28% increases to standard type. Read Section 13.5 "Detailed Accuracy" |
| | DY025 | 25mm | 15 (14.6) (mm) (Note 3) | 15 (14.6) (mm) (Note 3) | |
| | DY040 | 40mm | 25 (25.7) (mm) | 15 (14.6) (mm) (Note 3) | |
| | DY050 | 50mm | 40 (39.7) (mm) | 25 (25.7) (mm) | |
| | DY080 | 80mm | 50 (51.1) (mm) | 40 (39.7) (mm) | |
| | DY100 | 100mm | 80 (71) (mm) | 50 (51.1) (mm) | |
| | DY150 | 150mm | 100 (93.8) (mm) | 80 (71) (mm) | |
| | DY200 | 200mm | 150 (138.8) (mm) | 100 (93.8) (mm) | |
| Measurable minimum flow velocity | Liquid, Gas, Steam | | | Read Table 13.5. | |
| Range of measurable flow velocity | Liquid, Gas, Steam | | | Read Table 13.6. | |

(Note 1) For accuracy, read Section 13.5 "Detailed Accuracy". Combination with Cryogenic version /LT, Anti-Corrosion version I /HX1, /HX2, /HX3 is not available.

(Note 2) Flange type only: JIS10K, 20K (BJ1, BJ2) and ANSI150, 300 (BA1, BA2, BS1, BS2)

(Note 3) High process temperature version /HT and Multi-variable type /MV for DY025/R1 and DY040/R2 are not available.

(Note 4) Process connection code BA6 and CA6 are available for DY025/R1 to DY150/R1.

13.4 Sizing

The following items are the basic specifications.

In case of the definite sizing, it is necessary to check by the sizing software.

■ Measurable minimum flow velocity

Table 13.5 Relationship between Minimum Velocity and Density

| Model Code | | | Liquid | | Gas, Steam (Note1) | |
|---|---------------------------------|---------------------------------|---|---|---|---|
| Standard Type, Multi-Variable Type(/MV) | Reduced Bore Type (/R1) (Note2) | Reduced Bore Type (/R2) (Note2) | Standard Type, Cryogenic Version (/LT)(Note2), Multi-Variable Type (/MV) Unit: m/s | High Process Temperature Version(/HT), High Process Temperature Version Multi-Variable Type (/HT/MV) Unit: m/s | Standard Type, Cryogenic Version (/LT)(Note2), Multi-Variable Type (/MV) Unit: m/s | High Process Temperature Version(/HT), High Process Temperature Version Multi-Variable Type (/HT/MV) Unit: m/s |
| DY015 | DY025/R1 | DY040/R2 | $\sqrt{250/\rho}$ | — | $\sqrt{80/\rho}$ or 3 | — |
| DY025 | DY040/R1 | DY050/R2 | $\sqrt{122.5/\rho}$ | $\sqrt{490/\rho}$ | $\sqrt{45/\rho}$ or 2 | $\sqrt{125/\rho}$ or 2 |
| DY040 | DY050/R1 | DY080/R2 | $\sqrt{90/\rho}$ | $\sqrt{302.5/\rho}$ | $\sqrt{31.3/\rho}$ or 2 | $\sqrt{90.3/\rho}$ or 2 |
| DY050 | DY080/R1 | DY100/R2 | $\sqrt{90/\rho}$ | $\sqrt{160/\rho}$ | $\sqrt{31.3/\rho}$ or 2 | $\sqrt{61.3/\rho}$ or 2 |
| DY080 | DY100/R1 | DY150/R2 | $\sqrt{90/\rho}$ | $\sqrt{160/\rho}$ | $\sqrt{31.3/\rho}$ or 2 | $\sqrt{61.3/\rho}$ or 2 |
| DY100 | DY150/R1 | DY200/R2 | $\sqrt{90/\rho}$ | $\sqrt{160/\rho}$ | $\sqrt{31.3/\rho}$ or 2 | $\sqrt{61.3/\rho}$ or 2 |
| DY150 | DY200/R1 | — | $\sqrt{90/\rho}$ | $\sqrt{160/\rho}$ | $\sqrt{31.3/\rho}$ or 3 | $\sqrt{61.3/\rho}$ or 3 |
| DY200 | — | — | $\sqrt{122.5/\rho}$ | $\sqrt{202.5/\rho}$ | $\sqrt{45/\rho}$ or 3 | $\sqrt{80/\rho}$ or 3 |
| DY250 | — | — | $\sqrt{160/\rho}$ | $\sqrt{360/\rho}$ | $\sqrt{61.3/\rho}$ or 3 | $\sqrt{125/\rho}$ or 3 |
| DY300 | — | — | $\sqrt{160/\rho}$ | $\sqrt{360/\rho}$ | $\sqrt{61.3/\rho}$ or 3 | $\sqrt{125/\rho}$ or 3 |
| DY400 | — | — | $\sqrt{250/\rho}$ | $\sqrt{490/\rho}$ | $\sqrt{80/\rho}$ or 4 | $\sqrt{125/\rho}$ or 4 |

ρ : Density at operating conditions (kg/m³), Liquid density range is 400 to 2000 kg/cm³

(Note1) The case of gas, it is whichever is greater than a fixed value of each model and calculated from density.

(Note2) Reduced bore type /R1 or /R2 are not available to combine for Cryogenic Version /LT.

■ Range of measurable flow velocity

Table 13.6 Range of measurable flow velocity

| Fluid | Model Code | | | Minimum flow velocity | Maximum flow velocity |
|------------|----------------|------------------------|------------------------|---|-----------------------|
| Liquid | DY015 to DY400 | DY025 /R1 to DY200 /R1 | DY040 /R2 to DY200 /R2 | “flow velocity obtained from Table 13.5” or “flow velocity at Reynolds number of 5000”, whichever is greater. For liquid Reynolds number of 5000: Read Section 13.5 “Detailed Accuracy”. | 10m/s |
| Gas, Steam | DY015 to DY400 | DY025 /R1 to DY200 /R1 | DY040 /R2 to DY200 /R2 | “flow velocity obtained from Table 13.5” or “flow velocity at Reynolds number of 5000”, whichever is greater. For Gas and steam Reynolds number of 5000: Read Section 13.5 “Detailed Accuracy”. | 80m/s |

When the flow velocity is lower than minimum, both the analog output and the pulse output is displayed as “0”.

■ Range of fixed accuracy flow velocity

Table 13.7 Range of fixed accuracy flow velocity

| Fluid | Model Code | | | Minimum flow velocity | Maximum flow velocity |
|------------|----------------|------------------------|------------------------|---|-----------------------|
| Liquid | DY015 to DY100 | DY025 /R1 to DY150 /R1 | DY040 /R2 to DY200 /R2 | “flow velocity obtained from Table 13.5” or “flow velocity at Reynolds number of 20000”, whichever is greater. For liquid Reynolds number of 20000: The value is four times velocity value in Section 13.5 “Detailed Accuracy”. | 10m/s |
| | DY150 to DY400 | DY200 /R1 | — | “flow velocity obtained from Table 13.5” or “flow velocity at Reynolds number of 40000”, whichever is greater. For liquid Reynolds number of 40000: The value is eight times velocity value in Section 13.5 “Detailed Accuracy”. | |
| Gas, Steam | DY015 to DY100 | DY025 /R1 to DY150 /R1 | DY040 /R2 to DY200 /R2 | “flow velocity obtained from Table 13.5” or “flow velocity at Reynolds number of 20000”, whichever is greater. For gas and steam Reynolds number of 20000: Read Section 13.5 “Detailed Accuracy”. | 80m/s |
| | DY150 to DY400 | DY200 /R1 | — | “flow velocity obtained from Table 13.5” or “flow velocity at Reynolds number of 40000”, whichever is greater. For gas and steam Reynolds number of 40000: Read Section 13.5 “Detailed Accuracy”. | |

13.5 Detailed Accuracy

Accuracy is the value in range of fixed accuracy flow velocity. Read Table 13.7.

Volumetric flow rate at operation condition

| | Model Code | Standard Type | Multi-Variable Type (/MV) | Reduced Bore Type (/R1) | Reduced Bore Type (/R2) |
|---------------|------------|---|---|---|---|
| Liquid | DY015 | ±1.0% (20000≤Re<2000*D) ±0.75% (2000*D≤Re) | | | |
| | DY025 | ±1.0% (20000≤Re<1500*D) ±0.75% (1500*D≤Re) | ±1.0% (20000≤Re<1500*D) ±0.75% (1500*D≤Re) | | |
| | DY040 | ±1.0% (20000≤Re<1000*D) ±0.75% (1000*D≤Re) | ±1.0% (20000≤Re<1000*D) ±0.75% (1000*D≤Re) | ±1.0% | ±1.0% |
| | DY050 | | | | |
| | DY080 | | | | |
| | DY100 | | | | |
| | DY150 | ±1.0% (40000≤Re<1000*D) ±0.75% (1000*D≤Re) | ±1.0% (40000≤Re<1000*D) ±0.75% (1000*D≤Re) | ±1.0% (40000≤Re) | ±1.0% |
| | DY200 | | | | |
| | DY250 | | | | |
| | DY300 | | | | |
| DY400 | | | | | |
| Gas, Steam | DY015 | ±1.0% (Velocity 35m/s or less) ±1.5% (Velocity 35m/s to 80m/s) | ±1.0% (Velocity 35m/s or less) ±1.5% (Velocity 35m/s to 80m/s) | ±1.0% (Velocity 35m/s or less) ±1.5% (Velocity 35m/s to 80m/s) | ±1.0% (Velocity 35m/s or less) ±1.5% (Velocity 35m/s to 80m/s) |
| | DY025 | | | | |
| | DY040 | | | | |
| | DY050 | | | | |
| | DY080 | | | | |
| | DY100 | | | | |
| | DY150 | | | | |
| | DY200 | | | | |
| | DY250 | | | | |
| | DY300 | | | | |
| DY400 | | | | | |

D: Inner diameter of digitalYEWFL0 (mm)

Re: Reynolds number (non unit)

(Note 1): This table shows the accuracy of pulse output. In case of analog output, add up ± 0.1% of full scale to the values mentioned above. Guarantee conditions of liquid volumetric flow rate: the accuracy of a product before shipment in our water actual test facility. Totalized value of 2000 pulse or greater, straight pipe length: upper 10D or greater, lower 5D or greater, Fluid temp. 20 ± 10°C
 Gas, Steam: The accuracy which is add up from liquid measurement accuracy.
 The accuracy is confirmed by actual measured value of typical nominal size.

(Note 2): When select/set the mass flow unit in Standard Type, certainty of density that was set in the parameter will affect the accuracy of flow rate.

Mass flow or Volumetric flow rate at Normal/Standard condition:

for Multi-Variable Type and combination of Multi-Variable Type and Reduced Bore Type

| | Model Code | /MV | /MV/R1 | /MV/R2 |
|---------------|------------|---|---|---|
| Liquid | DY025 | ±2.0% (20000≤Re<1500*D) ±1.5% (1500*D≤Re) | ±2.0% (20000≤Re) | ±2.0% (20000≤Re) |
| | DY040 | | | |
| | DY050 | ±2.0%(20000≤Re<1000*D) ±1.5% (1000*D≤Re) | | |
| | DY080 | | | |
| | DY100 | | | |
| | DY150 | ±2.0% (40000≤Re<1000*D) ±1.5% (1000*D≤Re) | | |
| DY200 | | | | |
| Gas, Steam | DY025 | ±2.0% (Velocity 35m/s or less) ±2.5% (Velocity 35m/s to 80m/s) | ±2.0% (Velocity 35m/s or less) ±2.5% (Velocity 35m/s to 80m/s) | ±2.0% (Velocity 35m/s or less) ±2.5% (Velocity 35m/s to 80m/s) |
| | DY040 | | | |
| | DY050 | | | |
| | DY080 | | | |
| | DY100 | | | |
| | DY150 | | | |
| | DY200 | | | |

D: Inner diameter of digitalYEWFL0 (mm)

Re: Reynolds number (non unit)

(Note 1) This table shows the accuracy of pulse output. In case of analog output, add up ± 0.1% of full scale to the value mentioned above.

(Note 2) Mass flow accuracy is a calculated value obtained by adding density calculation accuracy based on volumetric flow rate accuracy.

(Note 3) For details on density calculation, read "OPTION MULTI-VARIABLE (BUILT-IN TEMPERATURE SENSOR) TYPE (/MV)".

(Note 4) Mass flow rate of superheated steam and volumetric flow rate of gas are calculated by constant pressure.

(Note 5) For the pressure, use the normal pressure value specified by sizing data.

(Note 6) The accuracy of saturated steam mass flow rate is on the condition of 100% dryness.

for High Temperature Version Multi-Variable Type and combination of High Temperature Multi-Variable Type and Reduced Bore Type

| | Model Code | /HT/MV | /HT/MV/R1 | /HT/MV/R2 |
|------------------------------|------------|---|---|---|
| Liquid | DY025 | ±2.0% (20000≤Re<1500*D) ±1.5% (1500*D≤Re) | ±2.0% (20000≤Re) | ±2.0% (20000≤Re) |
| | DY040 | | | |
| | DY050 | ±2.0%(20000≤Re<1000*D) ±1.5% (1000*D≤Re) | | |
| | DY080 | | | |
| | DY100 | | | |
| | DY150 | ±2.0% (40000≤Re<1000*D) ±1.5% (1000*D≤Re) | | |
| DY200 | | | | |
| Gas, Superheated Steam | DY025 | ±2.0% (Velocity 35m/s or less) ±2.5% (Velocity 35m/s to 80m/s) | ±2.0% (Velocity 35m/s or less) ±2.5% (Velocity 35m/s to 80m/s) | ±2.0% (Velocity 35m/s or less) ±2.5% (Velocity 35m/s to 80m/s) |
| | DY040 | | | |
| | DY050 | | | |
| | DY080 | | | |
| | DY100 | | | |
| | DY150 | | | |
| | DY200 | | | |
| Saturated Steam | DY025 | ±3.0% (Velocity 35m/s or less) ±3.5% (Velocity 35m/s to 80m/s) | ±3.0% (Velocity 35m/s or less) ±3.5% (Velocity 35m/s to 80m/s) | ±3.0% (Velocity 35m/s or less) ±3.5% (Velocity 35m/s to 80m/s) |
| | DY040 | | | |
| | DY050 | | | |
| | DY080 | | | |
| | DY100 | | | |
| | DY150 | | | |
| | DY200 | | | |

D: Inner diameter of digitalYEWFL0 (mm)

Re: Reynolds number (non unit)

(Note 1) This table shows the accuracy of pulse output. In case of analog output, add up ± 0.1% of full scale to the value mentioned above.

(Note 2) Mass flow accuracy is a calculated value obtained by adding density calculation accuracy based on volumetric flow rate accuracy.

(Note 3) For details on density calculation, read "OPTION MULTI-VARIABLE (BUILT-IN TEMPERATURE SENSOR) TYPE (/MV)".

(Note 4) Mass flow rate of superheated steam and volumetric flow rate of gas are calculated by constant pressure.

(Note 5) For the pressure, use the normal pressure value specified by sizing data.

(Note 6) The accuracy of saturated steam mass flow rate is on the condition of 100% dryness.

for Multi-Variable Type Temperature Accuracy

| | Model Code | Fluid Temperature | Accuracy | |
|-------------------|----------------|-------------------|-------------------|-------------------|
| | | | /MV | /HT/MV |
| Saturated Steam | DY025 to DY200 | < 100°C | ±0.5 °C | ±1.0 °C |
| Liquid | | ≥100°C | ±0.5 % of Reading | ±1.0 % of Reading |
| Superheated Steam | DY025 to DY200 | < 100°C | ±1.0 °C | ±1.0 °C |
| Gas | | ≥ 100°C | ±1.0 % of Reading | ±1.0 % of Reading |

Note1: In case of analog output, add up ±0.1% of full scale to the value mentioned above.

Note2: Measured temperature is not used for flow rate measurement.

■ **Calculation formula**

- How to calculate volume flow rate at operating conditions.

$$Q_f = 3600 \times v \times S \text{ or } Q_f = \frac{v \times D^2}{354}$$

- How to calculate the velocity of a Reynolds number.

- $v = 5 \times v / D$ (Reynolds number of 5000)
- $v = 20 \times v / D$ (Reynolds number of 20000)
- $v = 40 \times v / D$ (Reynolds number of 40000)

where

$$Re = \frac{354 \times 10^3 \times Q_f}{v \times D} \dots\dots\dots (1)$$

$$v = \frac{\mu}{\rho_f} \times 10^3 \dots\dots\dots (2)$$

- Q_f: Volume flow rate at operating conditions (m³/h)
- D: Inner diameter of digitalYEWFLO (mm)
- S: Sectional area of digitalYEWFLO (m²)
- v: Flow velocity (m/s)
- Re: Reynolds number (non unit)
- ρ_f: Density at operating conditions (kg/m³)
- μ: Viscosity at operating conditions (mPa·s (cP))
- v: Kinematic viscosity at operating conditions (10⁻⁶m²/s (cSt))

■ **Typical fluid example**

Table 13.8 Range of Measurable Water Flow Rate
(At standard condition of 15°C, ρ = 1000 kg/m³)

| Model Code | | | Measurable Flow Rate in m ³ /h | Range of Fixed Accuracy Flow Rate in m ³ /h |
|------------|----------|----------|---|--|
| DY015 | DY025/R1 | DY040/R2 | 0.30 to 6 | 0.94 to 6 |
| DY025 | DY040/R1 | DY050/R2 | 0.65 to 18 | 1.7 to 18 |
| DY040 | DY050/R1 | DY080/R2 | 1.3 to 44 | 2.6 to 44 |
| DY050 | DY080/R1 | DY100/R2 | 2.2 to 73 | 3.3 to 73 |
| DY080 | DY100/R1 | DY150/R2 | 4.3 to 142 | 4.6 to 142 |
| DY100 | DY150/R1 | DY200/R2 | 7.5 to 248 | 7.5 to 248 |
| DY150 | DY200/R1 | — | 17 to 544 | 18 to 544 |
| DY200 | — | — | 34 to 973 | 34 to 973 |
| DY250 | — | — | 60 to 1506 | 60 to 1506 |
| DY300 | — | — | 86 to 2156 | 86 to 2156 |
| DY400 | — | — | 177 to 3547 | 177 to 3547 |

Table 13.9 Range of Measurable Air Flow Rate at Selected Process Pressures

| Model Code | | | Flow Rate Limits | Minimum and Maximum Measurable Flow Rate in Nm ³ /h | | | | | | | | | |
|------------|-----------|-----------|------------------|--|------------|------------|------------|---------|---------|--------|---------|--------|---------|
| | | | | 0 MPa | 0.1 MPa | 0.2 MPa | 0.4 MPa | 0.6 MPa | 0.8 MPa | 1 MPa | 1.5 MPa | 2 MPa | 2.5 MPa |
| DY015 | DY025 /R1 | DY040 /R2 | min. | 4.8(11.1) | 6.7(11.1) | 8.2(11.1) | 10.5(11.1) | 12.5 | 16.1 | 19.7 | 28.6 | 37.5 | 46.4 |
| | | | max. | 48.2 | 95.8 | 143 | 239 | 334 | 429 | 524 | 762 | 1000 | 1238 |
| DY025 | DY040 /R1 | DY050 /R2 | min. | 11.0(19.5) | 15.5(19.5) | 19.0(19.5) | 24.5 | 29.0 | 33.3 | 40.6 | 59.0 | 77.5 | 95.9 |
| | | | max. | 149 | 297 | 444 | 739 | 1034 | 1329 | 1624 | 2361 | 3098 | 3836 |
| DY040 | DY050 /R1 | DY080 /R2 | min. | 21.8(30.0) | 30.8 | 37.8 | 48.7 | 61.6 | 79.2 | 97 | 149 | 184 | 229 |
| | | | max. | 356 | 708 | 1060 | 1764 | 2468 | 3171 | 3875 | 5634 | 7394 | 9153 |
| DY050 | DY080 /R1 | DY100 /R2 | min. | 36.2(38.7) | 51 | 62.4 | 80.5 | 102 | 131 | 161 | 233 | 306 | 379 |
| | | | max. | 591 | 1174 | 1757 | 2922 | 4088 | 5254 | 6420 | 9335 | 12249 | 15164 |
| DY080 | DY100 /R1 | DY150 /R2 | min. | 70.1 | 98.4 | 120 | 155 | 197 | 254 | 310 | 451 | 591 | 732 |
| | | | max. | 1140 | 2266 | 3391 | 5642 | 7892 | 10143 | 12394 | 18021 | 23648 | 29274 |
| DY100 | DY150 /R1 | DY200 /R2 | min. | 122 | 172 | 211 | 272 | 334 | 442 | 540 | 786 | 1031 | 1277 |
| | | | max. | 1990 | 3954 | 5919 | 9847 | 13775 | 17703 | 21632 | 31453 | 41274 | 51095 |
| DY150 | DY200 /R1 | — | min. | 268 | 377 | 485 | 808 | 1131 | 1453 | 1776 | 2583 | 3389 | 4196 |
| | | | max. | 4358 | 8659 | 12960 | 21559 | 30163 | 38765 | 47365 | 68867 | 90373 | 111875 |
| DY200 | — | — | min. | 575 | 809 | 990 | 1445 | 2202 | 2599 | 3175 | 4617 | 6059 | 7501 |
| | | | max. | 7792 | 15482 | 23172 | 38549 | 53933 | 69313 | 84693 | 123138 | 161591 | 200046 |
| DY250 | — | — | min. | 1037 | 1461 | 1788 | 2306 | 3127 | 4019 | 4911 | 7140 | 9370 | 11600 |
| | | | max. | 12049 | 23939 | 35833 | 59611 | 83400 | 107181 | 130968 | 190418 | 249881 | 309334 |
| DY300 | — | — | min. | 1485 | 2093 | 2561 | 3303 | 4479 | 5756 | 7033 | 10226 | 13419 | 16612 |
| | | | max. | 17256 | 34286 | 51317 | 85370 | 119441 | 153499 | 187556 | 272699 | 357856 | 443017 |
| DY400 | — | — | min. | 2790 | 3933 | 4812 | 7020 | 9821 | 12622 | 15422 | 22424 | 29426 | 36427 |
| | | | max. | 28378 | 56385 | 84391 | 140405 | 196418 | 252432 | 308445 | 448479 | 588513 | 728547 |

- (1) Listed flow rate is at standard conditions STP (0°C, 1atm).
- (2) Listed gauge pressure is at process temperature of 0°C.
- (3) Maximum flow rate is the lower of 80m/s.
- (4) Minimum flow rate: (value) is the lower limit of the accuracy range.

Table 13.10 Range of Measurable Saturated Steam Flow Rate at Selected Process Pressures

| Model Code | | | Flow Rate Limits | Minimum and Maximum Measurable Flow Rate in kg/h | | | | | | | | | |
|------------|-----------|-----------|------------------|--|------------|-----------|------------|------------|--------|---------|--------|---------|--------|
| | | | | 0.1 MPa | 0.2 MPa | 0.4 MPa | 0.6 MPa | 0.8 MPa | 1 MPa | 1.5 MPa | 2 MPa | 2.5 MPa | 3 MPa |
| DY015 | DY025 /R1 | DY040 /R2 | min. | 5.8(10.7) | 7.0(11.1) | 8.8(11.6) | 10.4(12.1) | 11.6(12.3) | 12.8 | 15.3 | 19.1 | 23.6 | 28.1 |
| | | | max. | 55.8 | 80 | 129 | 177 | 225 | 272 | 390 | 508 | 628 | 748 |
| DY025 | DY040 /R1 | DY050 /R2 | min. | 13.4(18.9) | 16.2(20.0) | 20.5 | 24.1 | 27.1 | 30 | 36 | 41 | 49 | 58 |
| | | | max. | 169.7 | 247.7 | 400 | 548 | 696 | 843 | 1209 | 1575 | 1945 | 2318 |
| DY040 | DY050 /R1 | DY080 /R2 | min. | 26.5(29.2) | 32 | 40.6 | 47.7 | 53.8 | 59 | 72 | 93 | 116 | 138 |
| | | | max. | 405 | 591 | 954 | 1310 | 1662 | 2012 | 2884 | 3759 | 4640 | 5532 |
| DY050 | DY080 /R1 | DY100 /R2 | min. | 44.0 | 53 | 67.3 | 79 | 89 | 98 | 119 | 156 | 192 | 229 |
| | | | max. | 671 | 979 | 1580 | 2170 | 2753 | 3333 | 4778 | 6228 | 7688 | 9166 |
| DY080 | DY100 /R1 | DY150 /R2 | min. | 84.9 | 103 | 130 | 152 | 171 | 189 | 231 | 300 | 371 | 442 |
| | | | max. | 1295 | 1891 | 3050 | 4188 | 5314 | 6435 | 9224 | 12024 | 14842 | 17694 |
| DY100 | DY150 /R1 | DY200 /R2 | min. | 148 | 179 | 227 | 267 | 300 | 330 | 402 | 524 | 647 | 772 |
| | | | max. | 2261 | 3300 | 5326 | 7310 | 9276 | 11232 | 16102 | 20986 | 25907 | 30883 |
| DY150 | DY200 /R1 | — | min. | 324 | 392 | 498 | 600 | 761 | 922 | 1322 | 1723 | 2127 | 2536 |
| | | | max. | 4950 | 7226 | 11661 | 16010 | 20315 | 24595 | 35258 | 45953 | 56729 | 67624 |
| DY200 | — | — | min. | 697 | 841 | 1068 | 1252 | 1410 | 1649 | 2364 | 3081 | 3803 | 4534 |
| | | | max. | 8851 | 12918 | 20850 | 28627 | 36325 | 43976 | 63043 | 82165 | 101433 | 120913 |
| DY250 | — | — | min. | 1256 | 1518 | 1929 | 2260 | 2546 | 2801 | 3655 | 4764 | 5882 | 7011 |
| | | | max. | 13687 | 19977 | 32243 | 44268 | 56172 | 68005 | 97489 | 127058 | 156854 | 186978 |
| DY300 | — | — | min. | 1799 | 2174 | 2762 | 3236 | 3646 | 4012 | 5235 | 6823 | 8423 | 10041 |
| | | | max. | 19602 | 28609 | 46175 | 63397 | 80445 | 97390 | 139614 | 181960 | 224633 | 267772 |
| DY400 | — | — | min. | 3381 | 4086 | 5187 | 6078 | 6848 | 8002 | 11472 | 14957 | 18468 | 22003 |
| | | | max. | 32217 | 47070 | 75834 | 104152 | 132193 | 160037 | 229449 | 299131 | 369366 | 440055 |

(1) Maximum flow rate is the lower of 80m/s.

(2) Minimum values are determined from Table 13.7. The values in parenthesis show the minimum linear flow rates (Re = 20,000 or 40,000) when they are higher than the minimum measurable flow rate.

■ Reference

Table 13.11 Inner Diameter and Nominal value

| Model Code | | | Inner Diameter mm | Nominal K-Factor Pulse/L | Nominal Pulse Rate | |
|------------|-----------|-----------|-------------------|--------------------------|--------------------|-----------|
| | | | | | Hz / m/s | Hz / m³/h |
| DY015 | DY025 /R1 | DY040 /R2 | 14.6 | 376 | 62.7 | 104 |
| DY025 | DY040 /R1 | DY050 /R2 | 25.7 | 68.6 | 35.5 | 19.1 |
| DY040 | DY050 /R1 | DY080 /R2 | 39.7 | 18.7 | 23.1 | 5.19 |
| DY050 | DY080 /R1 | DY100 /R2 | 51.1 | 8.95 | 18.3 | 2.49 |
| DY080 | DY100 /R1 | DY150 /R2 | 71.0 | 3.33 | 13.2 | 0.925 |
| DY100 | DY150 /R1 | DY200 /R2 | 93.8 | 1.43 | 9.88 | 0.397 |
| DY150 | DY200 /R1 | — | 138.8 | 0.441 | 6.67 | 0.123 |
| DY200 | — | — | 185.6 | 0.185 | 5.00 | 0.0514 |
| DY250 | — | — | 230.8 | 0.0966 | 4.04 | 0.0268 |
| DY300 | — | — | 276.2 | 0.0563 | 3.37 | 0.0156 |
| DY400 | — | — | 354.2 | 0.0265 | 2.61 | 0.00736 |

■ Pressure Loss

Calculation of pressure loss for standard type

obtained from the following equations.

$$\Delta P = 108 \times 10^{-5} \times \rho_f \times v^2 \dots\dots (1)$$

or

$$\Delta P = 135 \times \rho_f \times \frac{Q_f^2}{D^4} \dots\dots (2)$$

where,

- ΔP: Pressure loss (kPa)
- ρ_f: Density at operating condition (kg/m³)
- v: Flow velocity (m/s)
- Q_f: Actual flow rate (m³/h)
- D: Inner diameter of digital YEW FLO (mm)

(Example)

DY050, hot water: 80°C, flowrate: 30 m³/h

1. Since the density of water at 80°C is 972 kg/m³, substitute this value in equation (2):

$$\Delta P = 135 \times 972 \times 30^2 / 51.1^4 = 17.3 \text{ kPa}$$

2. Obtain the pressure loss using equation (1). The flow velocity when the flow rate is 30 m³/h is given by:

$$v = 354 \times Q_f / D^2 = \frac{354 \times 30}{51.1^2} = 4.07 \text{ m/s}$$

Therefore, substitute this value in equation (1):

$$\Delta P = 108 \times 10^{-5} \times 972 \times 4.07^2 = 17.3 \text{ kPa}$$

Calculation of pressure loss for reduced bore type (Option code: /R1)

obtained from the following equations.

$$\Delta P = 124 \times 10^{-5} \times \rho_f \times v^2 \dots\dots (3)$$

or

$$\Delta P = 155 \times \rho_f \times Q_f^2 / D^4 \dots\dots (4)$$

(Example)

DY040/R1, hot water: 50 °C, flowrate: 10 m³/h

1. Since the density of water at 50 °C is 992 kg/m³, substitute this value in equation (4):

$$\Delta P = 155 \times 992 \times 10^2 / 25.7^4 = 35.3 \text{ kPa}$$

2. Obtain by using equation (3). The flow velocity when the flow rate is 10 m³/h is given by:

$$v = 354 \times Q_f / D^2 = 354 \times 10 / 25.7^2 = 5.4 \text{ m/s}$$

Therefore, substitute this value in equation (3):

$$\Delta P = 124 \times 10^{-5} \times 992 \times 5.4^2 = 35.3 \text{ kPa}$$

Calculation of pressure loss for reduced bore type (Option code: /R2)

obtained from the following equations.

$$\Delta P = 138 \times 10^{-5} \times \rho_f \times v^2 \dots\dots (5)$$

or

$$\Delta P = 173 \times \rho_f \times \frac{Q_f^2}{D^4} \dots\dots (6)$$

(Example)

DY050-/R2, hot water: 50 °C, flowrate: 15 m³/h

1. Since the density of water at 50 °C is 992 kg/m³, substitute this value in equation (6):

$$\Delta P = 173 \times 992 \times 15^2 / 25.7^4 = 88.5 \text{ kPa}$$

2. Obtain by using equation (5). The flow velocity when the flow rate is 15m³/h is given by:

$$v = 354 \times Q_f / D^2 = \frac{354 \times 15}{25.7^2} = 8.0 \text{ m/s}$$

Therefore, substitute this value in equation (5):

$$\Delta P = 138 \times 10^{-5} \times 992 \times 8.0^2 = 88.5 \text{ kPa}$$

■ Cavitation

(Minimum Back Pressure, Liquid service only):

Cavitation occurs when the flow line pressure is low and flow velocity is high during fluid measurement, preventing correct measurement of flow rate. The optimum line pressure can be obtained from the following equation.

$$P = 2.7 \times \Delta P + 1.3 \times P_o \dots\dots\dots (7)$$

Where,

- P: Line pressure, 2 to 7 times as large as internal diameter on downstream of flowmeter body surface. (kPa absolute).
- ΔP: Pressure loss (kPa). Read the item above.
- Po: Saturation liquid vapor pressure at operating temperature (kPa absolute).

(Example) Confirmation of presence of cavitation Suppose that the line pressure is 120 kPa abs and the flow rate scale is 0 to 30 m³/h. It is only necessary to confirm the pressure at the maximum flow rate ; therefore, the saturated steam pressure of water at 80°C is as follows from the table of saturated steam pressures:

$$P_o = 47.4 \text{ kPa abs}$$

Therefore, substitute this value in equation (7):

$$P = 2.7 \times 17.3 + 1.3 \times 47.4 = 108.3 \text{ kPa abs}$$

Since the operating pressure of 120 kPa abs is higher than 108.3 kPa abs, no cavitation occurs.

■ Error that is due to the pressure change

In the measurement of gases and steam, in the case of handling the pressure as a fixed value it may have an error due to the pressure change occurs. In particular, since the pressure loss is increased at the same flow rate as compared to the standard form in reducer type, the difference occurs in the upstream line pressure and the downstream line pressure.

Since the vortex flowmeter must be corrected downstream line pressure, setting the upstream line pressure is subject to errors due to pressure differential.

Downstream line pressure is expressed by the following equation.

$$P_d = P_u - \Delta P$$

P_d: downstream line pressure (kPa abs)

P_u: upstream line pressure (kPa abs)

ΔP: Pressure loss (kPa)

(Example) calculation of the downstream line pressure

Calculate by a operating flow rate. This is an example of a volumetric flow rate at Normal condition (N: 1atm, 0 °C, 0%)

In this example, the maximum flow rate 0 to 1000Nm³/h, operating flow rate 700Nm³/h, the upstream line pressure 1000 kPa abs, temperature 30 °C, and the fluid density at operating condition 11.5kg/m³.

First, convert operating flow rate from volumetric flow rate at normal condition Q_n (Nm³/h) to the volumetric flow rate at operating condition Q_f (m³/h).

$$Q_f = Q_n \times \frac{P_n}{P_f} \times \frac{T_f}{T_n} \times K$$

$$= 700 \times \frac{101.3}{1000} \times \frac{273.15 + 30}{273.15} \times 1 = 78.7 \text{ (m}^3\text{/h)}$$

- P_n: Pressure value at Normal condition (kPa)
- P_f: Pressure value at Operating condition (kPa)
- T_n: Temperature value at Normal condition (°C)
- T_f: Temperature value at Operating condition (°C)
- K: deviation factor

Then, calculation formula of the "■ Pressure Loss" ((2), (4) or (6)) to calculate the pressure loss ΔP in the operating flow rate from to obtain the downstream line pressure P_d.

<In the case of standard type DY050>
 ΔP = 135 × 11.5 × 78.7² / 51.1⁴ = 1.4 (kPa)
 Therefore, it will be calculated as P_d = 1000-1.4 = 998.6 (kPa abs).

<In the case of reduced bore type DY050 / R1>
 ΔP = 155 × 11.5 × 78.7² / 39.7⁴ = 4.4 (kPa)
 Therefore, it will be calculated as P_d = 1000-4.4 = 995.6 (kPa abs).

<In the case of reduced bore type DY050 / R2>
 ΔP = 173 × 11.5 × 78.7² / 25.7⁴ = 28.2 (kPa)
 Therefore, it will be calculated as P_d = 1000-28.2 = 971.8 (kPa abs).

13.6 Option Specifications (For Explosion Protected Type)

* Process temperature and ambient temperature on this section are the specifications for explosion protected type. Read Section 13.1 "STANDARD SPECIFICATIONS" for the specifications of this product.

* Read "Contact rating" (in the Electrical Specifications, Transistor contact output) for the maximum current value of Pulse Circuit.

| Item | Specification | Code |
|---------------------|---|------|
| TIIS Certification | <p>TIIS Flameproof Approval (Note 1) Flameproof Ex d IIC T6 Certified by TIIS. (TIIS is the abbreviation of Technology Institution of Industrial Safety.) Amb. Temp: -20 to +60°C Electrical connection: JIS G1/2 female</p> | JF3 |
| Factory Mutual (FM) | <p>FM Explosion proof Approval Applicable Standard: Class3600, Class3611, Class3615, Class3810, ANSI/NEMA 250 Type of Protection: Explosion proof for Class I, Division 1, Groups A, B, C and D; Dust-ignitionproof Class II/III, Division 1, Groups E, F, and G. "SEAL ALL CONDUITS WITHIN 18 INCHES." "WHEN INSTALLED IN DIV.2, SEALS NOT REQUIRED." Enclosure Rating: Type 4X Temperature Code: T6 Ambient Temperature: -40 to +60°C Ambient Humidity: 0 to 100%RH (No condensation) Coating of Enclosure: Epoxy resin coating or Polyurethane resin coating. Electrical Connection: ANSI 1/2NPT female</p> | FF1 |
| | <p>FM Intrinsically safe Approval (Note 2) Applicable Standard: Class3600, Class3610, Class3611, Class3810, NEMA-250, ANSI/ISA 60079-0, ANSI/ISA 60079-11 Type of Protection: Intrinsically safe: Class I, Division 1, Groups A, B, C and D, T4 Class II, Division 1, Groups E, F and G, T4 Class III, Division 1, T4 Class I, Zone 0, AEx ia IIC T4 Nonincendive: Class I, Division 2, Groups A, B, C and D, T4 Class II, Division 2, Groups F and G, T4 Class III, Division 1, T4 Ambient Temperature: -40 to +60°C (Integral Type and Remote Type Converter) -40 to +80°C (Remote Type Detector) Ambient Humidity: 0 to 100% RH (No condensation) Indoors and Outdoors: Type 4X Electrical Parameter: Vmax=30Vdc, Imax=165mAdc, Pi=0.9W, Ci=12nF, Li=0.15mH Electrical Connection: ANSI 1/2NPT female</p> | FS1 |
| ATEX | <p>ATEX Flameproof Approval (Note 3) Applicable Standard: EN 60079-0, EN 60079-1 Type of Protection: Ex db IIC T6...T1 Gb (Integral Type and Remote Type Detector) Ex db IIC T6 Gb (Remote Type Converter) Groups: II, Category: 2 G Temperature Class: T6...T1 (Integral Type and Remote Type Detector) T6 (Remote Type Converter) Process Temp.: T6 (-40 to +80°C), T5 (-40 to +100°C), T4 (-40 to +135°C), T3 (-40 to +200°C), T2 (-40 to +300°C) T1 (-40 to +450°C) (Use /HT version above +250°C), Ambient temperature: -30 to +60°C (With indicator) -40 to +60°C (Without indicator) Ambient Humidity: 0 to 100%RH (No condensation) Electrical Connection: ANSI 1/2NPT female, ISO M20 × 1.5 female</p> | KF2 |
| | <p>ATEX Intrinsically Safe (Note2) Applicable Standard : EN 60079-0, EN60079-11 Type of protection: Ex ia IIC T4...T1Ga (Integral Type) Ex ia IIC T6...T1 Ga (Remote Type Detector) Ex ia IIC T4 Ga (Remote Type Converter) Groups: II, Category: 1 G Temperature Class: T4...T1(Integral Type) T6...T1(Remote Type Detector) T4 (Remote Type Converter) Ambient temperature: -50 to +60°C (Integral Type) -50 to +80[+79]°C (Remote Type Detector) (Option /LT below -29°C, [] for Option /MV at T6) -50 to +80°C (Remote Type Converter) Ambient Humidity: 5 to 100%RH (No condensation) Process temperature: T6: -196 to +84[+79]°C, T5: -196 to +100°C, T4: -196 to +135°C, T3: -196 to +199°C, T2: -196 to +299[+289]°C, T1: -196 to +449[+439]°C (Option /HT above +250°C and Option /LT below -29°C, [] : Option /MV) Signal/Supply (Terminals SUPPLY + and -) and Pulse (Terminals PULSE + and -) Circuit: Ui = 30 V, Ii = 300 mA, Pi = 0.9 W (linear source), Ci = 14 nF, Li = 0 mH Electrical connection: ANSI 1/2 NPT female, ISO M20 × 1.5 female</p> | KS2 |

(Note 1) The flameproof packing adapter /G11 or /G12 is necessary except the electrical conduit work. In case the ambient temperature exceeds 50°C, use heat resistant cables with maximum allowable temperature of 70°C or above.

(Note 2) For intrinsically safe approval, use the barrier certified by the testing laboratories.

(Note 3) Cryogenic Version /LT is not available.

| Item | Specification | Code |
|--------------------------------------|---|------|
| Canadian Standards Association (CSA) | <p>CSA Explosion proof Approval Applicable Standard: C22.1-98, C22.2 No.0, C22.2 No.0.4, C22.2 No.0.5, C22.2 No.25, C22.2 No.30, C22.2 No.94, C22.2 No.142, C22.2, No.61010-1, ANSI/ISA-12.27.01 Type of Protection: explosion-proof for Class I, Groups B, C and D; Class II, Groups E, F, and G; Class III. For Class I, Division 2 locations- "FACTORY SEALED, CONDUIT SEAL NOT REQUIRED" Temperature Class: T6...T1 (Integral Type and Remote Type Detector) T6 (Remote Type Converter) Amb.Temp.: -50 to +60°C Process temp.: T6; +85°C, T5; +100°C, T4; +135°C, T3; +200°C, T2; +300°C, T1; +450°C Enclosure: Type 4X Coating of Enclosure: Epoxy resin coating or Polyurethane resin coating. Electrical Connection: ANSI 1/2 NPT female</p> | CF1 |
| | <p>CSA Explosion proof Approval · The approval specification is the same with /CF1. · Process Sealing Certification Dual Seal Certified by CSA to the requirement of ANSI/ISA 12.27.01 No additional sealing required</p> | CF11 |
| | <p>CSA Intrinsically safe Approval (Note 2) Applicable Standard: C22.2 No. 0.4, C22.2 No. 157, C22.2 No. 213, C22.2 No. 1010.1, CAN/CSA-E60079-0, CAN/CSA-E60079-11, CAN/CSA-E60079-15 and ANSI/ISA 12.27.01 Type of Protection: Ex ia IIC T4...T1 and Ex nC IIC T4...T1 (Integral Type and Remote Type Detector) Ex ia IIC T4 and Ex nC IIC T4 (Remote Type Converter) Process Temp.: T4; +135°C, T3; +200°C, T2; +300°C, T1; +450°C (Integral Type and Remote Type Detector) Amb. Temp.: -40 to +60°C Amb. Hum.: 0 to 100%RH (No condensation) Degree of Protection of Enclosure: IP67 Electrical Parameter: Ui=30Vdc, Ii=165mAdc, Pi=0.9W, Ci=12nF, Li=0.15mH. Electrical Connection: ANSI 1/2 NPT female</p> <p>Type of Protection: Intrinsically Safe for Class I, II, III, DIV.1, Groups A, B, C, D, E, F and G Non-incendive for Class I, II, DIV.2, Groups A, B, C, D, F and G, ClassIII, DIV.1. Temperature Code: T4...T1(Integral Type and Remote Type Detector) T4(Remote Type Converter) Process Temp.: T4; +135°C, T3; +200°C, T2; +300°C, T1; +450°C (Integral Type and Remote Type Detector) Amb. Temp.: -40 to +60°C Amb. Hum.: 0 to 100%RH (No condensation) Enclosure: Type 4X Electrical Parameter: Vmax =30Vdc, I max =165mAdc, Pmax = 0.9W, Ci =12nF, Li = 0.15mH. Electrical Connection: ANSI 1/2 NPT female</p> | CS1 |
| | <p>CSA Intrinsically safe Approval · The approval specification is the same with /CS1. · Process Sealing Certification Dual Seal Certified by CSA to the requirement of ANSI/ISA 12.27.01 No additional sealing required</p> | CS11 |
| IECEx | <p>IECEx Flameproof Approval (Note 1) Applicable Standard: IEC60079-0, IEC60079-1 Type of Protection: Ex db IIC T6...T1 Gb (Integral Type and Remote Type Detector) Ex db IIC T6 Gb (Remote Type Converter) Temperature Class: T6...T1 (Integral Type and Remote Type Detector) T6 (Remote Type Converter) Process Temp.: T6(-40 to +80°C), T5(-40 to +100°C), T4(-40 to +135°C), T3(-40 to +200°C), T2(-40 to +300°C), T1(-40 to +450°C) (Use /HT version above +250°C) Ambient temperature: -30 to +60°C (With indicator) -40 to +60°C (Without indicator) Ambient Humidity: 0 to 100%RH Electrical Connection: ANSI 1/2NPT female, ISO M20 × 1.5 female</p> | SF2 |
| | <p>IECEx Intrinsically Safe (Note2) Applicable Standard : IEC 60079-0, IEC60079-11, IEC 60079-26 Type of protection: Ex ia IIC T4...T1Ga (Integral Type) Ex ia IIC T6...T1 Ga (Remote Type Detector) Ex ia IIC T4 Ga (Remote Type Converter) Temperature Class: T4...T1(Integral Type) T6...T1(Remote Type Detector) T4 (Remote Type Converter) Ambient temperature: -50 to +60°C (Integral Type) -50 to +80[+79]°C (Remote Type Detector) (Option /LT below -29°C, [] for Option /MV at T6) -50 to +80°C (Remote Type Converter) Ambient Humidity: 5 to 100%RH (No condensation) Process temperature: T6: -196 to +84[+79]°C, T5: -196 to +100°C, T4: -196 to +135°C, T3: -196 to +199°C, T2: -196 to +299[+289]°C, T1: -196 to +449[+439]°C (Option /HT above +250°C and Option /LT below -29°C, [] : Option /MV) Signal/Supply (Terminals SUPPLY + and -) and Pulse (Terminals PULSE + and -) Circuit: Ui = 30 V, Ii = 300 mA, Pi = 0.9 W (linear source), Ci = 14 nF, Li = 0 mH Electrical connection: ANSI 1/2 NPT female, ISO M20 × 1.5 female</p> | SS2 |

(Note 1) Cryogenic Version /LT is not available.

(Note 2) For intrinsically safe approval, use the barrier certified by the testing laboratories.

13.7 External Dimensions

■ Wafer type (DY015 to DY100)

Unit : mm
(approx. inch)

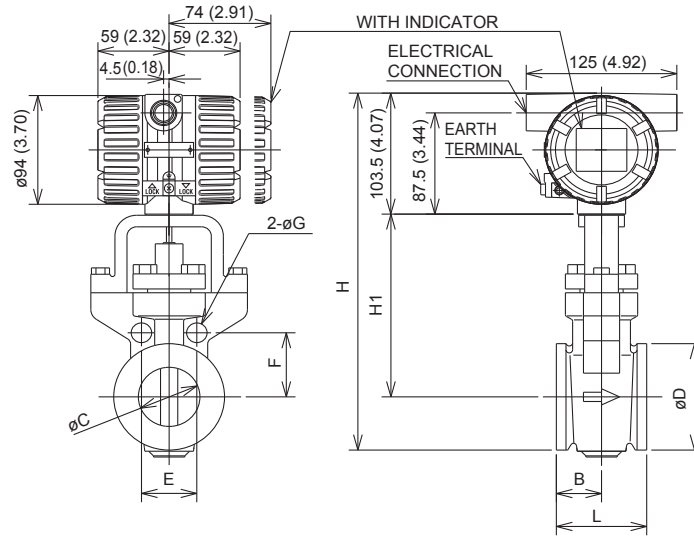

| TYPE | INTEGRAL/REMOTE | | | | | | | | | | | | | | | | | | | | |
|--------------------|-----------------|-------------|-------------|-------------|-------------|-------------|-------------|-------------|-------------|-------------|-----------|-------------|-------------|-------------|-------------|-------------|-------------|-------------|-------------|-------------|-------------|
| MODEL CODE | DY015 | | | | | | DY025 | | | | | | DY040 | | | | | | | | |
| PROCESS CONNECTION | AJ1 | AJ2 | AJ4 | AA1 | AA2 | AA4 | AD1 to AD4 | AJ1 | AJ2 | AJ4 | AA1 | AA2 | AA4 | AD1 to AD4 | AJ1 | AJ2 | AJ4 | AA1 | AA2 | AA4 | AD1 to AD4 |
| L | 70 (2.76) | | | | | | 70 (2.76) | | | | | | 70 (2.76) | | | | | | | | |
| B | 35 (1.38) | | | | | | 35 (1.38) | | | | | | 35 (1.38) | | | | | | | | |
| C | 14.6 (0.57) | | | | | | 25.7 (1.01) | | | | | | 39.7 (1.56) | | | | | | | | |
| D | 35.1 (1.38) | | | | | | 50.8 (2.00) | | | | | | 73 (2.87) | | | | | | | | |
| H | 248 (9.76) | | | | | | 258 (10.16) | | | | | | 276 (10.87) | | | | | | | | |
| H1 | 127 (5.00) | | | | | | 129 (5.08) | | | | | | 136 (5.35) | | | | | | | | |
| E | 49.5 (1.95) | 49.5 (1.95) | 56.6 (2.23) | 42.7 (1.68) | 47.1 (1.85) | 47.1 (1.85) | 46 (1.81) | 63.6 (2.50) | 63.6 (2.50) | 67.2 (2.65) | 56 (2.21) | 62.9 (2.48) | 62.9 (2.48) | 60.1 (2.37) | 74.2 (2.92) | 74.2 (2.92) | 84.9 (3.34) | 69.7 (2.74) | 80.8 (3.18) | 80.8 (3.18) | 77.8 (3.06) |
| F | 24.7 (0.97) | 24.7 (0.97) | 28.3 (1.11) | 21.4 (0.84) | 23.5 (0.93) | 23.5 (0.93) | 23 (0.91) | 31.8 (1.25) | 31.8 (1.25) | 33.6 (1.32) | 28 (1.10) | 31.4 (1.24) | 31.4 (1.24) | 30.1 (1.19) | 37.1 (1.46) | 37.1 (1.46) | 42.4 (1.67) | 34.8 (1.37) | 40.4 (1.59) | 40.4 (1.59) | 38.9 (1.53) |
| G | 13 (0.51) | 13 (0.51) | 17 (0.67) | 14 (0.55) | 14 (0.55) | 14 (0.55) | 13 (0.51) | 17 (0.67) | 17 (0.67) | 17 (0.67) | 14 (0.55) | 17 (0.67) | 17 (0.67) | 13 (0.51) | 17 (0.67) | 17 (0.67) | 21 (0.83) | 14 (0.55) | 20 (0.79) | 20 (0.79) | 17 (0.67) |
| WEIGHT kg (lb) | 2.8 (6.2) | | | | | | 3.7 (8.2) | | | | | | 4.3 (9.5) | | | | | | | | |

| TYPE | INTEGRAL/REMOTE | | | | | | | | | | | | | | | | | | | | | | |
|--------------------|-----------------|-------------|-------------|----------|-------------|-------------|-------------|-------------|-------------|-------------|----------|-------------|--------------|-------------|-------------|-------------|-------------|-------------|-------------|-------------|-------------|-------------|-------------|
| MODEL CODE | DY050 | | | | | | DY080 | | | | | | DY100 | | | | | | | | | | |
| PROCESS CONNECTION | AJ1 | AJ2 | AJ4 | AA1 | AA2 | AA4 | AD1 to AD4 | AJ1 | AJ2 | AJ4 | AA1 | AA2 | AA4 | AD1 AD2 | AD3 AD4 | AJ1 | AJ2 | AJ4 | AA1 | AA2 | AA4 | AD1 AD2 | AD3 AD4 |
| L | 75 (2.95) | | | | | | 100 (3.94) | | | | | | 120 (4.72) | | | | | | | | | | |
| B | 37.5 (1.48) | | | | | | 40 (1.57) | | | | | | 50 (1.97) | | | | | | | | | | |
| C | 51.1 (2.01) | | | | | | 71 (2.80) | | | | | | 93.8 (3.69) | | | | | | | | | | |
| D | 92 (3.62) | | | | | | 127 (5.00) | | | | | | 157.2 (6.19) | | | | | | | | | | |
| H | 307.5 (12.11) | | | | | | 342 (13.47) | | | | | | 372 (14.65) | | | | | | | | | | |
| H1 | 158 (6.22) | | | | | | 175 (6.89) | | | | | | 190 (7.48) | | | | | | | | | | |
| E | (Note 3) | 45.9 (1.81) | 49.8 (1.96) | (Note 3) | 48.6 (1.91) | 48.6 (1.91) | (Note 3) | 57.4 (2.26) | 61.2 (2.41) | 65.1 (2.56) | (Note 3) | 64.4 (2.54) | 64.4 (2.54) | 61.2 (2.41) | 61.2 (2.41) | 67 (2.64) | 70.8 (2.79) | 78.5 (3.09) | 72.9 (2.87) | 76.6 (3.02) | 82.6 (3.25) | 69.9 (2.71) | 72.7 (2.86) |
| F | (Note 3) | 55.4 (2.18) | 60.1 (2.36) | (Note 3) | 58.7 (2.31) | 58.7 (2.31) | (Note 3) | 69.3 (2.73) | 73.9 (2.91) | 78.5 (3.09) | (Note 3) | 77.7 (3.06) | 77.7 (3.06) | 73.9 (2.91) | 73.9 (2.91) | 80.8 (3.18) | 85.5 (3.37) | 94.7 (3.73) | 88 (3.46) | 92.5 (3.64) | 99.7 (3.93) | 83.1 (3.27) | 87.8 (3.46) |
| G | (Note 3) | 17 (0.67) | 17 (0.67) | (Note 3) | 17 (0.67) | 17 (0.67) | (Note 3) | 17 (0.67) | 21 (0.83) | 21 (0.83) | (Note 3) | 20 (0.79) | 20 (0.79) | 17 (0.67) | 17 (0.67) | 17 (0.67) | 21 (0.83) | 23 (0.91) | 17 (0.67) | 20 (0.79) | 23 (0.91) | 17 (0.67) | 21 (0.83) |
| WEIGHT kg (lb) | 6.0 (13.2) | | | | | | 9.4 (20.7) | | | | | | 12.8 (28.2) | | | | | | | | | | |

(Note 1) Integral weight is the same as Remote.
 (Note 2) In case of with Indicator, add 0.2kg (0.4lb).
 (Note 3) The holes are not provided.
 (Note 4) The flow direction is reversed (right to left when facing onto indicator) in case of code/CRC.

■ Flange type (DY015 to DY100)

Unit : mm
(approx. inch)

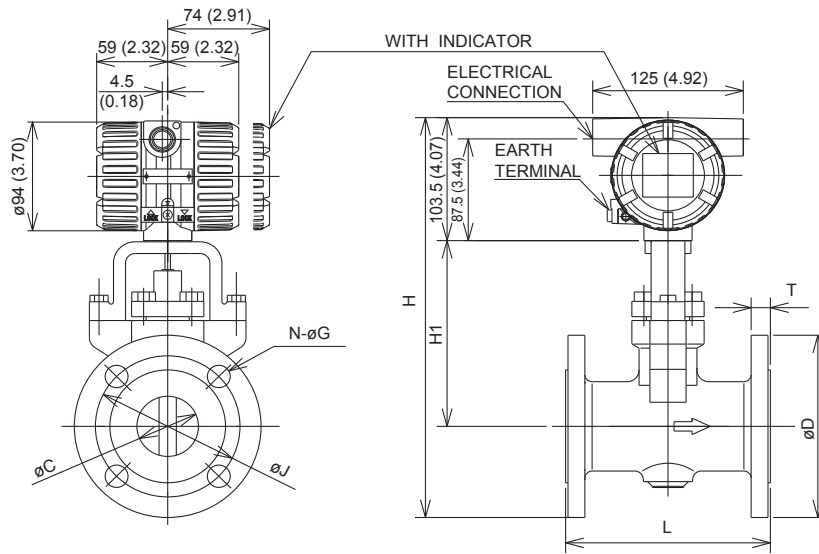

| TYPE | INTEGRAL/REMOTE | | | | | | | | | | | | | | | | | | | |
|--------------------|-----------------|-------------|-------------|-------------|-------------|-------------|--------------|-----------------------|-------------|--------------|-------------|-------------|---------------|---------------|---------------|---------------|--------------|-----------------------|---------------|--------------|
| MODEL CODE | DY015 | | | | | | | | | | DY025 | | | | | | | | | |
| PROCESS CONNECTION | BJ1 | BJ2 | BJ4 | BA1 BS1 | BA2 BS2 | BA4 BS4 | BA5 BS5 | BD1 to BD4 FD1 to FD4 | CA4 | CA5 | BJ1 | BJ2 | BJ4 | BA1 BS1 | BA2 BS2 | BA4 BS4 | BA5 BS5 | BD1 to BD4 FD1 to FD4 | CA4 | CA5 |
| L | 130 (5.12) | | | | | 160 (6.30) | | | | | 150 (5.91) | | | | | | | | | |
| C | 14.6 (0.58) | | | | | | | | | | 25.7 (1.01) | | | | | | | | | |
| D | 95 (3.74) | 95 (3.74) | 115 (4.53) | 88.9 (3.50) | 95.3 (3.75) | 95.3 (3.75) | 120.7 (4.75) | 95 (3.74) | 95.3 (3.75) | 120.7 (4.75) | 125 (4.92) | 125 (4.92) | 130 (5.12) | 108 (4.25) | 124 (4.88) | 124 (4.88) | 149.4 (5.88) | 115 (4.53) | 124 (4.88) | 149.4 (5.88) |
| H | 278 (10.94) | 278 (10.94) | 288 (11.34) | 275 (10.83) | 278 (10.94) | 278 (10.94) | 291 (11.46) | 278 (10.94) | 278 (10.94) | 291 (11.46) | 295 (11.61) | 295 (11.61) | 297.5 (11.81) | 285.5 (11.28) | 294.5 (11.59) | 294.5 (11.59) | 307 (12.09) | 290 (11.42) | 294.5 (11.59) | 307 (12.09) |
| H1 | 127 (5.00) | | | | | | | | | | 129 (5.08) | | | | | | | | | |
| T | 12 (0.47) | 14 (0.55) | 20 (0.79) | 11.2 (0.44) | 14.2 (0.56) | 21 (0.83) | 28.8 (1.13) | 16 (0.63) | 19.9 (0.78) | 28.8 (1.13) | 14 (0.55) | 16 (0.63) | 22 (0.87) | 14.2 (0.56) | 17.5 (0.69) | 24 (0.94) | 34.9 (1.37) | 18 (0.71) | 24 (0.94) | 34.9 (1.37) |
| J | 70 (2.76) | 70 (2.76) | 80 (7.15) | 60.5 (2.38) | 66.5 (2.62) | 82.6 (3.25) | 65 (2.56) | 66.5 (2.62) | 82.6 (3.25) | 90 (3.54) | 90 (3.54) | 95 (3.74) | 79.2 (3.12) | 89 (3.50) | 89 (3.50) | 101.6 (4.00) | 85 (3.35) | 89 (3.50) | 101.6 (4.00) | |
| N | 4 | | | | | | | | | | 4 | | | | | | | | | |
| G | 15 (0.59) | 15 (0.59) | 19 (0.75) | 15.7 (0.62) | 15.7 (0.62) | 22.4 (0.88) | 14 (0.55) | 15.7 (0.62) | 22.4 (0.88) | 19 (0.75) | 19 (0.75) | 19 (0.75) | 15.7 (0.62) | 19 (0.75) | 19 (0.75) | 25.4 (1.00) | 14 (0.55) | 19 (0.75) | 25.4 (1.00) | |
| WEIGHT kg (lb) | 4.2 (9.26) | 4.3 (9.48) | 5.9 (13.01) | 4.1 (9.04) | 4.3 (9.48) | 6.7 (14.77) | 4.2 (9.26) | 4.5 (9.92) | 6.8 (14.99) | 6.9 (15.21) | 7.1 (15.66) | 8.6 (18.96) | 6.6 (14.55) | 7.2 (15.88) | 7.7 (16.98) | 11.1 (24.48) | 6.9 (15.21) | 7.9 (17.42) | 11.4 (25.14) | |

| TYPE | INTEGRAL/REMOTE | | | | | | | | | | | | | | | | | | | |
|--------------------|-----------------|---------------|---------------|-------------|--------------|--------------|---------------|-----------------------|--------------|---------------|--------------|--------------|--------------|---------------|--------------|--------------|--------------|-----------------------|--------------|--------------|
| MODEL CODE | DY040 | | | | | | | | | | DY050 | | | | | | | | | |
| PROCESS CONNECTION | BJ1 | BJ2 | BJ4 | BA1 BS1 | BA2 BS2 | BA4 BS4 | BA5 BS5 | BD1 to BD4 FD1 to FD4 | CA4 | CA5 | BJ1 | BJ2 | BJ4 | BA1 BS1 | BA2 BS2 | BA4 BS4 | BA5 BS5 | BD1 to BD4 FD1 to FD4 | CA4 | CA5 |
| L | 150 (5.91) | | | | | 200 (7.87) | | | | | 170 (6.69) | | | | | | | | | |
| C | 39.7 (1.56) | | | | | | | | | | 51.1 (2.01) | | | | | | | | | |
| D | 140 (5.51) | 140 (5.51) | 160 (6.30) | 127 (5.00) | 155.4 (6.12) | 155.4 (6.12) | 177.8 (7.00) | 150 (5.91) | 155.4 (6.12) | 177.8 (7.00) | 155 (6.10) | 155 (6.10) | 165 (6.50) | 152.4 (6.00) | 165.1 (6.50) | 165.1 (6.50) | 215.9 (8.50) | 165 (6.50) | 165.1 (6.50) | 215.9 (8.50) |
| H | 309.5 (12.19) | 309.5 (12.19) | 319.5 (12.58) | 303 (11.93) | 317 (12.48) | 317 (12.48) | 328.5 (12.93) | 314.5 (12.38) | 317 (12.48) | 328.5 (12.93) | 339 (13.35) | 339 (13.35) | 344 (13.54) | 337.5 (13.29) | 344 (13.54) | 344 (13.54) | 393.5 (15.5) | 344 (13.54) | 344 (13.54) | 393.5 (15.5) |
| H1 | 136 (5.35) | | | | | | | | | | 158 (6.22) | | | | | | | | | |
| T | 16 (0.63) | 18 (0.71) | 26 (1.02) | 17.5 (0.69) | 20.6 (0.81) | 28.8 (1.13) | 38.2 (1.50) | 18 (0.71) | 28.8 (1.13) | 38.2 (1.50) | 16 (0.63) | 18 (0.71) | 26 (1.02) | 19.1 (0.75) | 22.4 (0.88) | 31.8 (1.25) | 44.5 (1.75) | 20 (0.79) | 33.3 (1.31) | 46 (1.81) |
| J | 105 (4.13) | 105 (4.13) | 120 (4.72) | 98.6 (3.88) | 114.3 (4.50) | 114.3 (4.50) | 124 (4.88) | 110 (4.33) | 114.3 (4.50) | 124 (4.88) | 120 (4.72) | 120 (4.72) | 130 (5.12) | 120.7 (4.75) | 127 (5.00) | 127 (5.00) | 165.1 (6.50) | 125 (4.92) | 127 (5.00) | 165.1 (6.50) |
| N | 4 | | | | | | | | | | 4 | | | | | | | | | |
| G | 19 (0.75) | 19 (0.75) | 23 (0.91) | 15.7 (0.62) | 22.4 (0.88) | 28.4 (1.12) | 18 (0.71) | 22.4 (0.88) | 28.4 (1.12) | 19 (0.75) | 19 (0.75) | 19 (0.75) | 19 (0.75) | 19 (0.75) | 19 (0.75) | 25.4 (1.00) | 18 (0.71) | 19 (0.75) | 25.4 (1.00) | |
| WEIGHT kg (lb) | 8.2 (18.08) | 8.4 (18.52) | 11.9 (26.24) | 8.1 (17.86) | 9.3 (20.51) | 11.3 (24.92) | 16.2 (35.72) | 8.8 (19.4) | 11.7 (25.8) | 16.3 (35.94) | 11.1 (24.48) | 11.6 (25.58) | 14.3 (31.53) | 11.7 (25.8) | 13.2 (29.11) | 14.6 (32.63) | 26.5 (58.43) | 11.3 (24.92) | 15.8 (34.84) | 26.9 (59.31) |

| TYPE | INTEGRAL/REMOTE | | | | | | | | | | | | | | | | | | | | | |
|--------------------|-----------------|---------------|---------------|--------------|---------------|---------------|--------------|-----------------------|-----------------------|---------------|--------------|---------------|--------------|---------------|--------------|---------------|---------------|---------------|-----------------------|-----------------------|---------------|---------------|
| MODEL CODE | DY080 | | | | | | | | | | DY100 | | | | | | | | | | | |
| PROCESS CONNECTION | BJ1 | BJ2 | BJ4 | BA1 BS1 | BA2 BS2 | BA4 BS4 | BA5 BS5 | BD1 to BD2 FD1 to FD2 | BD3 to BD4 FD3 to FD4 | CA4 | CA5 | BJ1 | BJ2 | BJ4 | BA1 BS1 | BA2 BS2 | BA4 BS4 | BA5 BS5 | BD1 to BD2 FD1 to FD2 | BD3 to BD4 FD3 to FD4 | CA4 | CA5 |
| L | 200 (7.87) | | | | | 245 (9.65) | | | | | 200 (7.87) | | | | | 235 (9.25) | | | | | | |
| C | 71 (2.80) | | | | | | | | | | 93.8 (3.69) | | | | | | | | | | | |
| D | 185 (7.28) | 200 (7.87) | 210 (8.27) | 190.5 (7.50) | 209.6 (8.25) | 209.6 (8.25) | 241.3 (9.50) | 200 (7.87) | 200 (7.87) | 209.6 (8.25) | 241.3 (9.50) | 210 (8.27) | 225 (8.90) | 250 (9.84) | 228.6 (9.00) | 254 (10.00) | 273 (10.75) | 282.1 (11.50) | 220 (8.66) | 235 (9.25) | 273 (10.75) | 282.1 (11.50) |
| H | 371 (14.61) | 378.5 (14.90) | 383.5 (15.10) | 374 (14.72) | 383.5 (15.10) | 383.5 (15.10) | 399 (15.71) | 378.5 (14.90) | 378.5 (14.90) | 383.5 (15.10) | 399 (15.71) | 388.5 (15.69) | 406 (15.98) | 418.5 (16.48) | 409 (16.10) | 420.5 (16.56) | 430 (16.93) | 439.5 (17.30) | 403.5 (15.89) | 411 (16.16) | 430 (16.93) | 439.5 (17.30) |
| H1 | 175 (6.89) | | | | | | | | | | 190 (7.48) | | | | | | | | | | | |
| T | 18 (0.71) | 22 (0.87) | 32 (1.26) | 23.9 (0.94) | 28.4 (1.12) | 38.2 (1.50) | 44.5 (1.75) | 20 (0.79) | 24 (0.95) | 39.7 (1.56) | 46 (1.81) | 18 (0.71) | 24 (0.95) | 36 (1.42) | 23.9 (0.94) | 31.8 (1.25) | 44.5 (1.75) | 50.9 (2.00) | 20 (0.79) | 24 (0.95) | 46 (1.81) | 52.4 (2.06) |
| J | 150 (5.91) | 160 (6.30) | 170 (6.69) | 152.4 (6.00) | 168.2 (6.62) | 168 (6.61) | 190.5 (7.50) | 160 (6.30) | 170 (6.69) | 180 (7.09) | 175 (6.89) | 185 (7.28) | 205 (8.07) | 190.5 (7.50) | 200.2 (7.88) | 216 (8.50) | 235 (9.25) | 180 (7.09) | 190 (7.48) | 216 (8.50) | 235 (9.25) | |
| N | 8 | | | | | | | | | | 8 | | | | | | | | | | | |
| G | 19 (0.75) | 23 (0.91) | 23 (0.91) | 19 (0.75) | 22.4 (0.88) | 22.4 (0.88) | 25.4 (1.00) | 18 (0.71) | 18 (0.71) | 22.4 (0.88) | 25.4 (1.00) | 19 (0.75) | 19 (0.75) | 23 (0.91) | 25 (0.98) | 19 (0.75) | 22.4 (0.88) | 25.4 (1.00) | 18 (0.71) | 22 (0.87) | 25.4 (1.00) | 31.8 (1.25) |
| WEIGHT kg (lb) | 17.4 (38.37) | 20 (44.1) | 25.4 (56.01) | 20 (44.1) | 23.8 (52.48) | 25.4 (56.01) | 35.7 (78.72) | 19.4 (42.78) | 20 (44.1) | 27.1 (59.76) | 36.3 (80.04) | 22.8 (50.27) | 26.8 (59.09) | 38.1 (84.01) | 27.4 (60.42) | 35.9 (79.16) | 50.8 (112.01) | 35.9 (79.16) | 23.2 (51.16) | 27.4 (60.42) | 52.8 (116.42) | 56.8 (124.8) |

- (Note 1) Integral weight is the same as Remote.
- (Note 2) In case of with Indicator, add 0.2kg (0.4lb).
- (Note 3) The flow direction is reversed (right to left when facing onto indicator) in case of code/CRC.

■ Flange type (DY150 to DY400)

Unit : mm
(approx. inch)

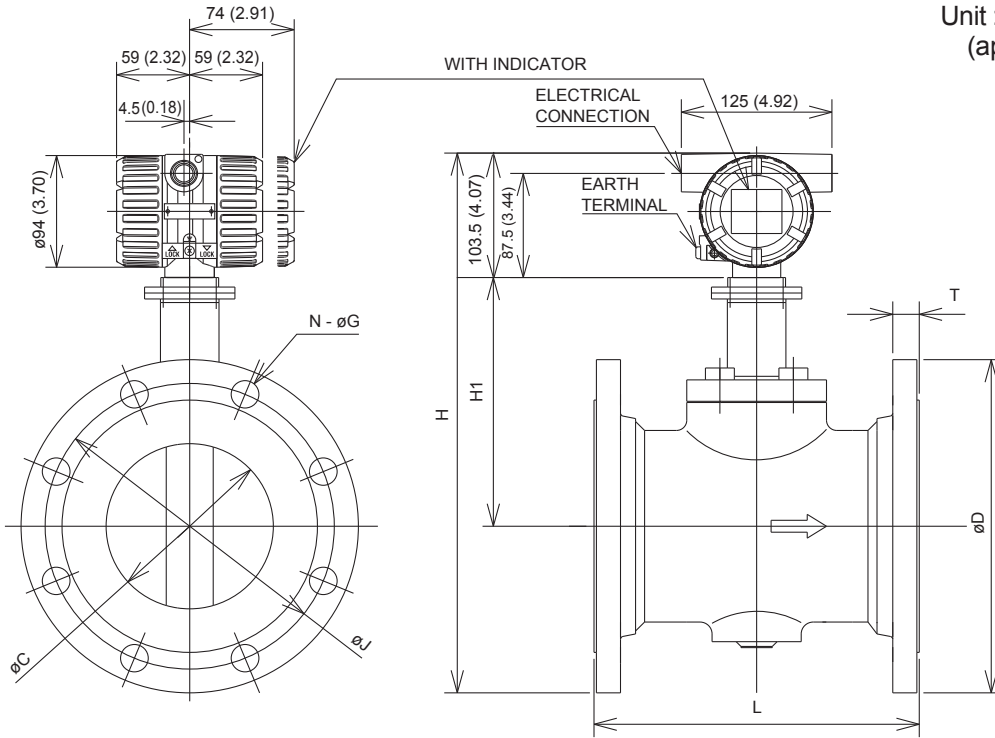

| TYPE | INTEGRAL/REMOTE | | | | | | | | | | | | | | | | | | | | | | |
|--------------------|-----------------|-------------|---------------|---------------|---------------|---------------|---------------|-----------------------|-----------------------|-------------|---------------|---------------|---------------|---------------|---------------|---------------|---------------|---------------|---------------|---------------|---------------|---------------|---------------|
| MODEL CODE | DY150 | | | | | | | | | | DY200 | | | | | | | | | | | | |
| PROCESS CONNECTION | BJ1 | BJ2 | BJ4 | BA1 BS1 | BA2 BS2 | BA4 BS4 | BA5 BS5 | BD1 to BD2 FD1 to FD2 | BD3 to BD4 FD3 to FD4 | CA4 | CA5 | BJ1 | BJ2 | BA1 BS1 | BA2 BS2 | BA4 BS4 | BA5 BS5 | BD1 FD1 | BD2 FD2 | BD3 FD3 | BD4 FD4 | CA4 | CA5 |
| L | 270 (10.63) | | | | | | | | | | 310 (12.20) | | | | | | | | | | | | |
| C | 138.8 (5.46) | | | | | | | | | | 185.6 (7.31) | | | | | | | | | | | | |
| D | 280 (11.02) | 305 (12.01) | 355 (13.98) | 279.4 (11.00) | 317.5 (12.50) | 356 (14.02) | 381 (15.00) | 285 (11.22) | 300 (11.81) | 356 (14.02) | 381 (15.00) | 330 (12.99) | 350 (13.78) | 342.9 (13.50) | 381 (15.00) | 419.1 (16.50) | 469.9 (18.50) | 340 (13.39) | 340 (13.39) | 360 (14.17) | 375 (14.76) | 419.1 (16.50) | 469.9 (18.50) |
| H | 453 (17.83) | 465 (18.31) | 490 (19.29) | 452 (17.80) | 471 (18.54) | 491 (19.33) | 503 (19.80) | 455 (17.91) | 463 (18.23) | 491 (19.33) | 503 (19.80) | 510 (20.08) | 520 (20.47) | 516 (20.31) | 535 (21.06) | 554 (21.81) | 579 (22.80) | 515 (20.28) | 515 (20.28) | 525 (20.67) | 532 (20.94) | 554 (21.81) | 579 (22.80) |
| H1 | 209 (8.23) | | | | | | | | | | 241 (9.49) | | | | | | | | | | | | |
| T | 216 (8.50) | | | | | | | | | | 248 (9.76) | | | | | | | | | | | | |
| J | 240 (9.45) | 260 (10.24) | 295 (11.61) | 241.3 (9.50) | 289.7 (11.42) | 292 (11.50) | 317.5 (12.50) | 240 (9.45) | 250 (9.84) | 292 (11.50) | 317.5 (12.50) | 240 (9.45) | 250 (9.84) | 290 (11.42) | 305 (12.01) | 330.2 (13.00) | 349.3 (13.75) | 295 (11.61) | 295 (11.61) | 310 (12.20) | 320 (12.60) | 349.3 (13.75) | 393.7 (15.50) |
| N | 8 | 12 | 12 | 8 | 12 | 12 | 12 | 8 | 12 | 12 | 12 | 12 | 12 | 8 | 12 | 12 | 12 | 8 | 12 | 12 | 12 | 12 | 12 |
| G | 23 (0.91) | 25 (0.98) | 33 (1.30) | 22.4 (0.88) | 28.4 (1.12) | 31.8 (1.25) | 31.8 (1.25) | 22 (0.87) | 26 (1.02) | 28.4 (1.12) | 31.8 (1.25) | 23 (0.91) | 22.4 (0.88) | 25 (1.00) | 31.8 (1.25) | 38.1 (1.50) | 46.3 (1.82) | 22 (0.87) | 22 (0.87) | 26 (1.02) | 30 (1.18) | 31.8 (1.25) | 38.1 (1.50) |
| WEIGHT kg (lb) | 33.4 (73.65) | 43.4 (95.7) | 76.4 (168.46) | 36.4 (80.26) | 54.4 (119.95) | 84.4 (186.10) | 106 (233.73) | 33.4 (73.65) | 42.9 (94.59) | 90 (198.45) | 107 (235.94) | 45.4 (100.11) | 52.4 (115.54) | 55.4 (122.16) | 80.4 (177.28) | 136 (299.88) | 182 (401.31) | 46.3 (102.09) | 46.3 (102.09) | 53.6 (118.19) | 55.9 (123.26) | 139 (306.52) | 183 (403.52) |

| TYPE | INTEGRAL/REMOTE | | | | | | | | | | | |
|--------------------|-----------------|-------------|---------------|---------------|---------------|--------------|---------------|---------------|---------------|-------------|---------------|--------------|
| MODEL CODE | DY250 | | | | DY300 | | | | DY400 | | | |
| PROCESS CONNECTION | BJ1 | BJ2 | BA1 BS1 | BA2 BS2 | BJ1 | BJ2 | BA1 BS1 | BA2 BS2 | BJ1 | BJ2 | BA1 BS1 | BA2 BS2 |
| L | 370 (14.57) | | | | 400 (15.75) | | | | 520 (20.47) | | | |
| C | 230.8 (9.09) | | | | 276.2 (10.87) | | | | 354.2 (13.94) | | | |
| D | 400 (15.75) | 430 (16.93) | 406.4 (16.00) | 444.5 (17.50) | 445 (17.52) | 480 (18.90) | 482.6 (19.00) | 520.7 (20.50) | 560 (22.05) | 605 (23.82) | 596.9 (23.5) | 647.7 (25.5) |
| H | 581 (22.87) | 596 (23.46) | 584 (22.99) | 603 (23.74) | 633 (24.92) | 651 (25.63) | 652 (25.67) | 671 (26.42) | 757.5 (29.82) | 780 (30.71) | 776 (30.55) | 801 (31.54) |
| H1 | 277 (10.91) | | | | 307 (12.09) | | | | 374 (14.72) | | | |
| T | 24 (0.94) | 34 (1.34) | 30.2 (1.19) | 47.8 (1.88) | 24 (0.94) | 31.8 (1.25) | 31.8 (1.25) | 50.8 (2.00) | 28 (1.10) | 46 (1.81) | 36.6 (1.44) | 57.2 (2.25) |
| J | 355 (13.98) | 380 (14.96) | 382 (14.25) | 387.4 (15.25) | 400 (15.75) | 430 (16.93) | 431.8 (17.00) | 450.9 (17.75) | 510 (20.08) | 540 (21.26) | 539.8 (21.25) | 571.5 (22.5) |
| N | 12 | 12 | 12 | 16 | 16 | 16 | 12 | 16 | 16 | 16 | 16 | 20 |
| G | 25 (0.98) | 27 (1.06) | 25.4 (1.00) | 28.5 (1.12) | 25 (0.98) | 27 (1.06) | 25.4 (1.00) | 31.8 (1.25) | 27 (1.06) | 33 (1.30) | 28.5 (1.12) | 35.1 (1.38) |
| WEIGHT kg (lb) | 78 (171.99) | 100 (220.5) | 90 (198.45) | 125 (275.63) | 100 (220.5) | 128 (282.24) | 140 (308.7) | 178 (392.49) | 265 (584.2) | 308 (679) | 300 (661.4) | 370 (815.7) |

- (Note 1) Integral weight is the same as Remote.
- (Note 2) In case of with Indicator, add 0.2kg (0.4lb).
- (Note 3) The flow direction is reversed (right to left when facing onto indicator) in case of code/CRC.
- (Note 4) In case of code /HX2, add 5.1kg (11.2lb).

- High Process Temperature Version (/HT): DY025/HT to DY100/HT
- Cryogenic Version (/LT): DY015/LT to DY100/LT
- Wafer type

Unit : mm
(approx. inch)

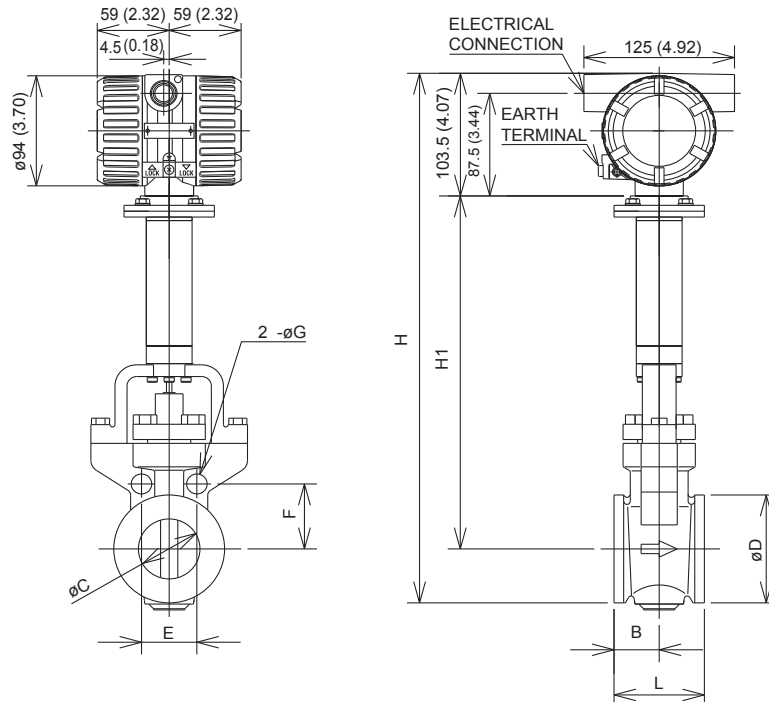

| TYPE | REMOTE | | | | | | | | | | | | | | | | | | | | |
|--------------------|-------------|-------------|-------------|-------------|-------------|-------------|--------------------|-------------|-------------|-------------|-----------|-------------|--------------------|-------------|-------------|-------------|-------------|-------------|-------------|-------------|-------------|
| MODEL CODE | DY015/LT | | | | | | DY025/LT, DY025/HT | | | | | | DY040/LT, DY040/HT | | | | | | | | |
| PROCESS CONNECTION | AJ1 | AJ2 | AJ4 | AA1 | AA2 | AA4 | AD1 to AD4 | AJ1 | AJ2 | AJ4 | AA1 | AA2 | AA4 | AD1 to AD4 | AJ1 | AJ2 | AJ4 | AA1 | AA2 | AA4 | AD1 to AD4 |
| L | 70 (2.76) | | | | | | 70 (2.76) | | | | | | 70 (2.76) | | | | | | | | |
| B | 35 (1.38) | | | | | | 35 (1.38) | | | | | | 35 (1.38) | | | | | | | | |
| C | 14.6 (0.57) | | | | | | 25.7 (1.01) | | | | | | 39.7 (1.56) | | | | | | | | |
| D | 35.1 (1.38) | | | | | | 50.8 (2.00) | | | | | | 73 (2.87) | | | | | | | | |
| H | 391 (15.39) | | | | | | 401 (15.79) | | | | | | 419 (16.50) | | | | | | | | |
| H1 | 270 (10.63) | | | | | | 272 (10.71) | | | | | | 279 (10.98) | | | | | | | | |
| E | 49.5 (1.95) | 49.5 (1.95) | 56.6 (2.23) | 42.7 (1.68) | 47.1 (1.85) | 47.1 (1.85) | 46 (1.81) | 63.6 (2.50) | 63.6 (2.50) | 67.2 (2.65) | 56 (2.20) | 62.9 (2.48) | 62.9 (2.48) | 60.1 (2.37) | 74.2 (2.92) | 74.2 (2.92) | 84.9 (3.34) | 69.7 (2.74) | 80.8 (3.18) | 80.8 (3.18) | 77.8 (3.06) |
| F | 24.7 (0.97) | 24.7 (0.97) | 28.3 (1.11) | 21.4 (0.84) | 23.5 (0.93) | 23 (0.91) | 23 | 31.8 (1.25) | 31.8 (1.25) | 33.6 (1.32) | 28 (1.10) | 31.4 (1.24) | 31.4 (1.24) | 30.1 (1.19) | 37.1 (1.46) | 37.1 (1.46) | 42.4 (1.67) | 34.8 (1.37) | 40.4 (1.59) | 40.4 (1.59) | 38.9 (1.53) |
| G | 13 (0.51) | 13 (0.51) | 17 (0.67) | 14 (0.55) | 14 (0.55) | 13 (0.51) | 13 | 17 (0.67) | 17 (0.67) | 17 (0.67) | 14 (0.55) | 17 (0.67) | 17 (0.67) | 13 (0.51) | 17 (0.67) | 17 (0.67) | 21 (0.83) | 14 (0.55) | 20 (0.79) | 20 (0.79) | 17 (0.67) |
| WEIGHT kg (lb) | 3.2 (7.06) | | | | | | 4.1 (9.04) | | | | | | 4.7 (10.36) | | | | | | | | |

| TYPE | REMOTE | | | | | | | | | | | | | | | | | | | | | | |
|--------------------|--------------------|-------------|-------------|----------|-------------|-------------|--------------------|-------------|-------------|-------------|----------|-------------|--------------------|-------------|-------------|-------------|-------------|-------------|-------------|-------------|-------------|-------------|-------------|
| MODEL CODE | DY050/LT, DY050/HT | | | | | | DY080/LT, DY080/HT | | | | | | DY100/LT, DY100/HT | | | | | | | | | | |
| PROCESS CONNECTION | AJ1 | AJ2 | AJ4 | AA1 | AA2 | AA4 | AD1 to AD4 | AJ1 | AJ2 | AJ4 | AA1 | AA2 | AA4 | AD1 AD2 | AD3 AD4 | AJ1 | AJ2 | AJ4 | AP1 AA1 | AP2 AA2 | AP4 AA4 | AD1 AD2 | AD3 AD4 |
| L | 75 (2.95) | | | | | | 100 (3.94) | | | | | | 120 (4.72) | | | | | | | | | | |
| B | 37.5 (1.48) | | | | | | 40 (1.57) | | | | | | 50 (1.97) | | | | | | | | | | |
| C | 51.1 (2.01) | | | | | | 71 (2.80) | | | | | | 93.8 (3.69) | | | | | | | | | | |
| D | 92 (3.62) | | | | | | 127 (5.00) | | | | | | 157.2 (6.19) | | | | | | | | | | |
| H | 450.5 (17.74) | | | | | | 485 (19.09) | | | | | | 515 (20.28) | | | | | | | | | | |
| H1 | 301 (11.85) | | | | | | 318 (12.52) | | | | | | 333 (13.11) | | | | | | | | | | |
| E | (Note 1) | 45.9 (1.81) | 49.8 (1.96) | (Note 1) | 48.6 (1.91) | 48.6 (1.91) | (Note 1) | 57.4 (2.26) | 61.2 (2.41) | 65.1 (2.56) | (Note 1) | 64.4 (2.54) | 64.4 (2.54) | 61.2 (2.41) | 61.2 (2.41) | 67 (2.64) | 70.8 (2.79) | 78.5 (3.09) | 72.9 (2.87) | 76.6 (3.02) | 82.6 (3.25) | 68.9 (2.71) | 72.7 (2.86) |
| F | (Note 1) | 55.4 (2.18) | 60.1 (2.37) | (Note 1) | 58.7 (2.31) | 58.7 (2.31) | (Note 1) | 69.3 (2.73) | 73.9 (2.91) | 78.5 (3.09) | (Note 1) | 77.7 (3.06) | 77.7 (3.06) | 73.9 (2.91) | 73.9 (2.91) | 80.8 (3.18) | 85.5 (3.37) | 94.7 (3.73) | 88 (3.46) | 92.5 (3.64) | 99.7 (3.93) | 83.1 (3.27) | 87.8 (3.46) |
| G | (Note 1) | 17 (0.67) | 17 (0.67) | (Note 1) | 17 (0.67) | 17 (0.67) | (Note 1) | 17 (0.67) | 21 (0.83) | 21 (0.83) | (Note 1) | 20 (0.79) | 20 (0.79) | 17 (0.67) | 17 (0.67) | 17 (0.67) | 21 (0.83) | 23 (0.91) | 17 (0.67) | 20 (0.79) | 23 (0.91) | 17 (0.67) | 21 (0.83) |
| WEIGHT kg (lb) | 6.4 (14.11) | | | | | | 9.8 (21.61) | | | | | | 13.2 (29.11) | | | | | | | | | | |

(Note 1) The holes are not provided.
(Note 2) The flow direction is reversed (right to left when facing onto indicator) in case of code/CRC.

- High Process Temperature Version (/HT): DY025/HT to DY100/HT
- Cryogenic Version (/LT): DY015/LT to DY100/LT
- Flange type

Unit : mm
(approx. inch)

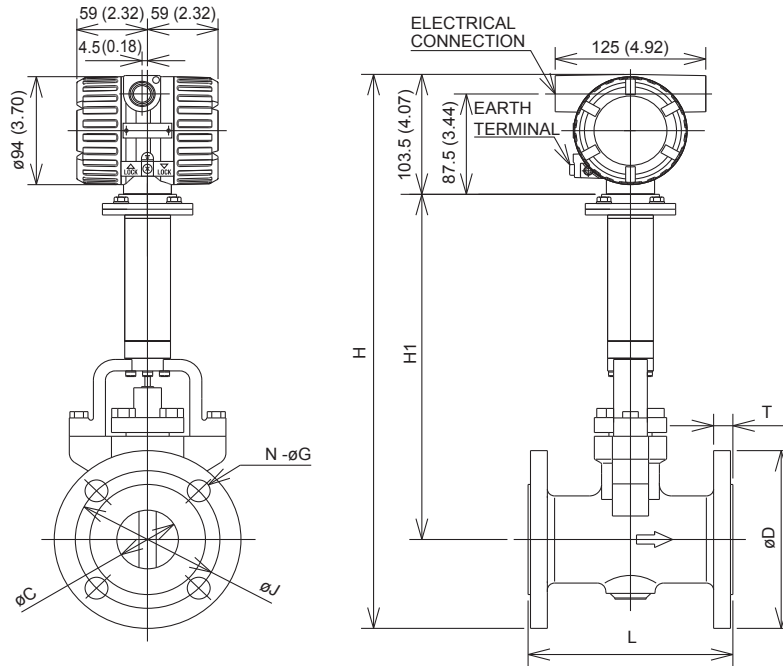

| TYPE | REMOTE | | | | | | | | | | | | | | | | | | | | |
|--------------------|-------------|-------------|-------------|-------------|-------------|-------------|--------------|-------------|-------------|--------------------|-------------|-------------|-------------|--------------|-------------|-------------|--------------|-----------------------|-------------|-------------|--------------|
| MODEL CODE | DY015/LT | | | | | | | | | DY025/LT, DY025/HT | | | | | | | | | | | |
| PROCESS CONNECTION | BJ1 | BJ2 | BJ4 | BA1 BS1 | BA2 BS2 | BA4 BS4 | BA5 BS5 | BD1 to BD4 | CA4 | CA5 | BJ1 | BJ2 | BJ4 | BA1 BS1 | BA2 BS2 | BA4 BS4 | BA5 BS5 | BD1 to BD4 FD1 to FD4 | CA4 | CA5 | |
| L | 130 (5.12) | | | | | | | | | 150 (5.91) | | | | | | | | | | | |
| C | 14.6 (0.57) | | | | | | | | | 25.7 (1.01) | | | | | | | | | | | |
| D | 95 (3.74) | 95 (3.74) | 115 (4.53) | 88.9 (3.50) | 95.3 (3.75) | 95.3 (3.75) | 120.7 (4.75) | 95 (3.74) | 95.3 (3.75) | 120.7 (4.75) | 125 (4.92) | 125 (4.92) | 130 (5.12) | 108 (4.25) | 124 (4.88) | 124 (4.88) | 149.4 (5.88) | 115 (4.53) | 124 (4.88) | 124 (4.88) | 149.4 (5.88) |
| H | 421 (16.57) | 421 (16.57) | 431 (16.97) | 418 (16.46) | 421 (16.57) | 421 (16.57) | 434 (17.09) | 421 (16.57) | 421 (16.57) | 434 (17.09) | 438 (17.24) | 438 (17.24) | 441 (17.36) | 430 (16.93) | 438 (17.24) | 438 (17.24) | 450 (17.72) | 433 (17.05) | 433 (17.05) | 438 (17.24) | 450 (17.72) |
| H1 | 270 (10.63) | | | | | | | | | 272 (10.71) | | | | | | | | | | | |
| T | 12 (0.47) | 14 (0.55) | 20 (0.79) | 11.2 (0.44) | 14.2 (0.56) | 21 (0.83) | 28.8 (1.13) | 16 (0.63) | 16 (0.63) | 22.4 (0.88) | 14 (0.55) | 16 (0.63) | 22 (0.87) | 14.2 (0.56) | 17.5 (0.69) | 24 (0.94) | 34.9 (1.37) | 18 (0.71) | 18 (0.71) | 24 (0.94) | 34.9 (1.37) |
| J | 70 (2.76) | 70 (2.76) | 80 (3.15) | 60.5 (2.39) | 66.5 (2.62) | 66.5 (2.62) | 82.6 (3.25) | 65 (2.56) | 65 (2.56) | 82.6 (3.25) | 90 (3.54) | 90 (3.54) | 95 (3.74) | 79.2 (3.12) | 89 (3.50) | 89 (3.50) | 101.6 (4.00) | 85 (3.35) | 85 (3.35) | 89 (3.50) | 101.6 (4.00) |
| N | 4 | | | | | | | | | 4 | | | | | | | | | | | |
| G | 15 (0.59) | 15 (0.59) | 19 (0.75) | 15.7 (0.62) | 15.7 (0.62) | 22.4 (0.88) | 14 (0.55) | 15.7 (0.62) | 15.7 (0.62) | 22.4 (0.88) | 19 (0.75) | 19 (0.75) | 19 (0.75) | 15.7 (0.62) | 19 (0.75) | 19 (0.75) | 25.4 (1.00) | 14 (0.55) | 14 (0.55) | 19 (0.75) | 25.4 (1.00) |
| WEIGHT kg (lb) | 4.6 (10.14) | 4.7 (10.36) | 6.3 (13.89) | 4.5 (9.92) | 4.7 (10.36) | 5 (11.03) | 7.1 (15.66) | 4.6 (10.14) | 4.6 (10.14) | 7.3 (16.08) | 19 (42.24) | 19 (42.24) | 19 (42.24) | 15.7 (34.85) | 19 (42.24) | 19 (42.24) | 25.4 (56.11) | 14 (31.23) | 14 (31.23) | 19 (42.24) | 25.4 (56.11) |

| TYPE | REMOTE | | | | | | | | | | | | | | | | | | | | |
|--------------------|--------------------|-------------|--------------|-------------|--------------|--------------|--------------|-----------------------|--------------|--------------------|-------------|-------------|--------------|--------------|--------------|--------------|--------------|-----------------------|-------------|--------------|-------------|
| MODEL CODE | DY040/LT, DY040/HT | | | | | | | | | DY050/LT, DY050/HT | | | | | | | | | | | |
| PROCESS CONNECTION | BJ1 | BJ2 | BJ4 | BA1 BS1 | BA2 BS2 | BA4 BS4 | BA5 BS5 | BD1 to BD4 FD1 to FD4 | CA4 | CA5 | BJ1 | BJ2 | BJ4 | BA1 BS1 | BA2 BS2 | BA4 BS4 | BA5 BS5 | BD1 to BD4 FD1 to FD4 | CA4 | CA5 | |
| L | 150 (5.91) | | | | | | | | | 170 (6.69) | | | | | | | | | | | |
| C | 39.7 (1.56) | | | | | | | | | 51.1 (2.01) | | | | | | | | | | | |
| D | 140 (5.51) | 140 (5.51) | 160 (6.30) | 127 (5.00) | 155.4 (6.12) | 155.4 (6.12) | 177.8 (7.00) | 150 (5.91) | 155.4 (6.12) | 177.8 (7.00) | 155 (6.10) | 155 (6.10) | 165 (6.50) | 152.4 (6.00) | 165.1 (6.50) | 165.1 (6.50) | 215.9 (8.50) | 165 (6.50) | 165 (6.50) | 215.9 (8.50) | |
| H | 453 (17.83) | 453 (17.83) | 463 (18.23) | 446 (17.56) | 460 (18.11) | 460 (18.11) | 472 (18.58) | 458 (18.03) | 458 (18.03) | 472 (18.58) | 482 (18.98) | 482 (18.98) | 487 (19.17) | 481 (18.94) | 487 (19.17) | 487 (19.17) | 513 (20.20) | 487 (19.17) | 487 (19.17) | 513 (20.20) | |
| H1 | 279 (10.98) | | | | | | | | | 301 (11.85) | | | | | | | | | | | |
| T | 16 (0.63) | 16 (0.71) | 26 (1.02) | 17.5 (0.69) | 20.5 (0.81) | 28.8 (1.13) | 38.2 (1.50) | 18 (0.71) | 18 (0.71) | 28.8 (1.13) | 16 (0.63) | 18 (0.71) | 26 (1.02) | 19.1 (0.75) | 22.4 (0.88) | 31.9 (1.25) | 44.5 (1.75) | 20 (0.79) | 20 (0.79) | 33.3 (1.31) | 46 (1.81) |
| J | 105 (4.13) | 105 (4.13) | 120 (4.72) | 98.6 (3.88) | 114.3 (4.50) | 114.3 (4.50) | 124 (4.88) | 110 (4.33) | 114.3 (4.50) | 124 (4.88) | 120 (4.72) | 120 (4.72) | 130 (5.12) | 120 (4.75) | 127 (5.00) | 127 (5.00) | 166.1 (6.50) | 127 (5.00) | 127 (5.00) | 166.1 (6.50) | |
| N | 4 | | | | | | | | | 4 | | | | | | | | | | | |
| G | 19 (0.75) | 19 (0.75) | 23 (0.91) | 15.7 (0.62) | 22.4 (0.88) | 22.4 (0.88) | 28.4 (1.12) | 18 (0.71) | 22.4 (0.88) | 28.4 (1.12) | 19 (0.75) | 19 (0.75) | 19 (0.75) | 15.7 (0.62) | 19 (0.75) | 19 (0.75) | 25.4 (1.00) | 18 (0.71) | 18 (0.71) | 25.4 (1.00) | |
| WEIGHT kg (lb) | 8.6 (18.96) | 8.8 (19.4) | 12.3 (27.12) | 8.5 (18.74) | 9.7 (21.39) | 9.7 (21.39) | 11.7 (25.8) | 9.2 (20.29) | 9.2 (20.29) | 11.5 (25.68) | 12 (26.46) | 12 (26.46) | 14.7 (32.42) | 12.1 (26.68) | 13.6 (29.99) | 15.2 (33.52) | 26.9 (59.32) | 11.7 (25.8) | 11.7 (25.8) | 16.2 (35.72) | 27.3 (60.2) |

| TYPE | REMOTE | | | | | | | | | | | | | | | | | | | | | |
|--------------------|--------------------|--------------|--------------|--------------|--------------|--------------|--------------|-----------------------|-----------------------|--------------------|--------------|--------------|--------------|--------------|--------------|--------------|--------------|---------------|-----------------------|-----------------------|-------------|---------------|
| MODEL CODE | DY080/LT, DY080/HT | | | | | | | | | DY100/LT, DY100/HT | | | | | | | | | | | | |
| PROCESS CONNECTION | BJ1 | BJ2 | BJ4 | BA1 BS1 | BA2 BS2 | BA4 BS4 | BA5 BS5 | BD1 to BD2 FD1 to FD2 | BD3 to BD4 FD3 to FD4 | CA4 | CA5 | BJ1 | BJ2 | BJ4 | BA1 BS1 | BA2 BS2 | BA4 BS4 | BA5 BS5 | BD1 to BD2 FD1 to FD2 | BD3 to BD4 FD3 to FD4 | CA4 | CA5 |
| L | 200 (7.87) | | | | | | | | | 220 (8.66) | | | | | | | | | | | | |
| C | 71 (2.80) | | | | | | | | | 93.8 (3.69) | | | | | | | | | | | | |
| D | 185 (7.29) | 200 (7.87) | 210 (8.27) | 190.5 (7.50) | 209.6 (8.25) | 209.6 (8.25) | 241.3 (9.50) | 200 (7.87) | 200 (7.87) | 209.6 (8.25) | 241.3 (9.50) | 210 (8.27) | 225 (8.86) | 250 (9.84) | 228.6 (9.00) | 254 (10.00) | 273 (10.75) | 292.1 (11.50) | 220 (8.66) | 220 (8.66) | 273 (10.75) | 292.1 (11.50) |
| H | 514 (20.24) | 522 (20.55) | 527 (20.75) | 517 (20.35) | 527 (20.75) | 527 (20.75) | 542 (21.34) | 522 (20.55) | 522 (20.55) | 527 (20.75) | 542 (21.34) | 542 (21.34) | 549 (21.61) | 562 (22.13) | 552 (21.73) | 564 (22.20) | 573 (22.56) | 583 (22.95) | 547 (21.54) | 547 (21.54) | 554 (21.81) | 573 (22.56) |
| H1 | 318 (12.52) | | | | | | | | | 333 (13.11) | | | | | | | | | | | | |
| T | 18 (0.71) | 22 (0.87) | 32 (1.26) | 23.9 (0.94) | 28.4 (1.12) | 38.2 (1.50) | 44.5 (1.75) | 20 (0.79) | 24 (0.94) | 39.7 (1.56) | 46 (1.81) | 18 (0.71) | 24 (0.94) | 36 (1.42) | 33.9 (1.32) | 31.8 (1.25) | 44.5 (1.75) | 50.9 (2.00) | 20 (0.79) | 24 (0.94) | 46 (1.81) | 52.4 (2.06) |
| J | 150 (5.91) | 160 (6.30) | 170 (6.69) | 152.4 (6.00) | 168.2 (6.62) | 168 (6.61) | 190.5 (7.50) | 160 (6.30) | 160 (6.30) | 170 (6.69) | 180 (7.09) | 175 (6.89) | 185 (7.29) | 205 (8.07) | 190.5 (7.50) | 200.2 (7.87) | 216 (8.50) | 235 (9.25) | 180 (7.09) | 190 (7.48) | 216 (8.50) | 235 (9.25) |
| N | 8 | | | | | | | | | 8 | | | | | | | | | | | | |
| G | 19 (0.75) | 23 (0.91) | 23 (0.91) | 19 (0.75) | 22.4 (0.88) | 22.4 (0.88) | 25.4 (1.00) | 18 (0.71) | 18 (0.71) | 22.4 (0.88) | 25.4 (1.00) | 19 (0.75) | 23 (0.91) | 25 (0.98) | 19 (0.75) | 22.4 (0.88) | 25.4 (1.00) | 31.8 (1.25) | 18 (0.71) | 18 (0.71) | 22 (0.87) | 31.8 (1.25) |
| WEIGHT kg (lb) | 17.8 (39.25) | 20.4 (44.96) | 25.8 (56.89) | 20.4 (44.96) | 24.2 (53.36) | 24.2 (53.36) | 36.1 (79.6) | 19.8 (43.66) | 19.8 (43.66) | 20.4 (44.96) | 27.5 (60.64) | 23.2 (51.16) | 27.2 (59.98) | 38.5 (84.89) | 27.3 (60.04) | 36.3 (80.04) | 51.2 (112.9) | 56.3 (124.14) | 23.6 (52.04) | 23.6 (52.04) | 27.8 (61.3) | 53.2 (117.31) |

(Note 1) The flow direction is reversed (right to left when facing onto indicator) in case of code/CRC.

■ High Process Temperature Version (/HT): DY150/HT to DY400/HT

■ Flange type

Unit : mm
(approx. inch)

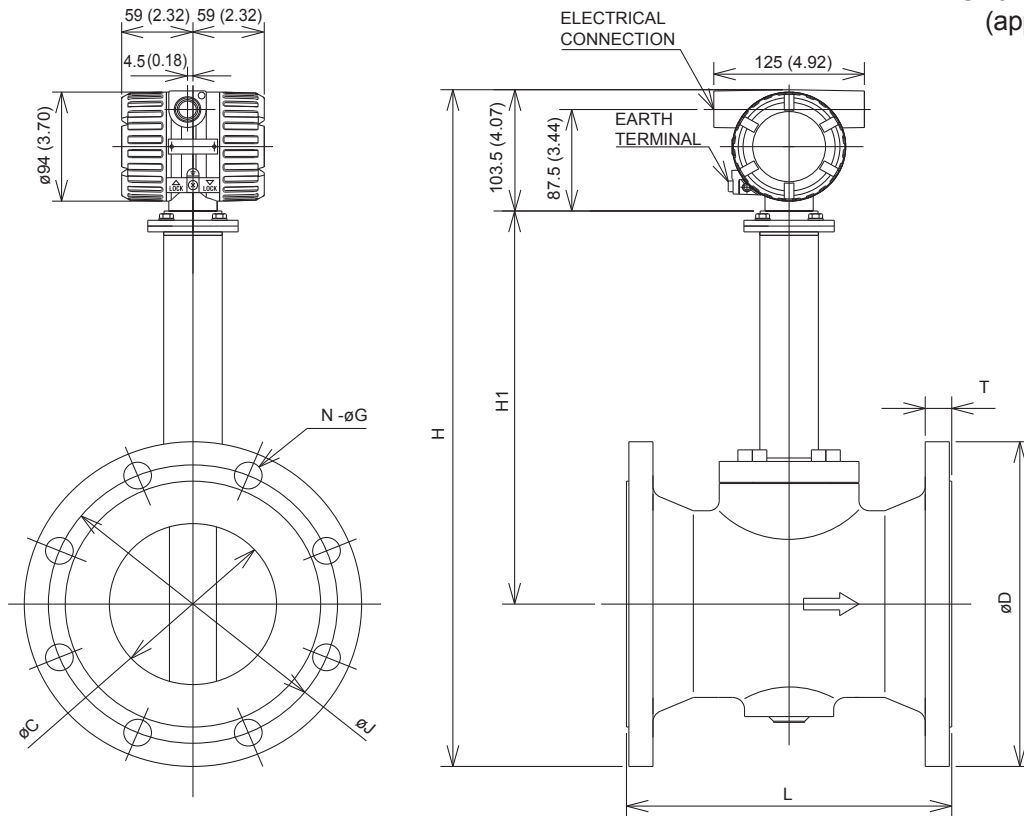

| TYPE | REMOTE | | | | | | | | | | | | | | | | | | | | | | | |
|----------------|-------------------------|-------------|---------------|---------------|---------------|--------------|---------------|-----------------------|-----------------------|--------------|---------------|---------------|---------------|---------------|---------------|---------------|---------------|---------------|---------------|---------------|---------------|---------------|---------------|-------------|
| | DY150/HT | | | | | | | | | DY200/HT | | | | | | | | | | | | | | |
| MODEL CODE | BJ1 | BJ2 | BJ4 | BA1 BS1 | BA2 BS2 | BA4 BS4 | BA5 BS5 | BD1 to BD2 FD1 to FD2 | BD3 to BD4 FD3 to FD4 | CA4 | CA5 | BJ1 | BJ2 | BA1 BS1 | BA2 BS2 | BA4 BS4 | BA5 BS5 | BD1 FD1 | BD2 FD2 | BD3 FD3 | BD4 FD4 | CA4 | CA5 | |
| L | 270 (10.63) | | | | | | | | | 325 (12.80) | | | | | | | | | | | | | | |
| C | 138.8 (5.46) | | | | | | | | | 185.6 (7.31) | | | | | | | | | | | | | | |
| D | 280 (11.02) | 305 (12.01) | 355 (13.98) | 279.4 (11.00) | 317.5 (12.50) | 356 (14.02) | 381 (15.00) | 285 (11.22) | 300 (11.81) | 356 (14.02) | 381 (15.00) | 330 (12.99) | 350 (13.78) | 342.9 (13.50) | 381 (15.00) | 419.1 (16.50) | 469.9 (18.50) | 340 (13.39) | 340 (13.39) | 360 (14.17) | 375 (14.76) | 419.1 (16.50) | 469.9 (18.50) | |
| H | Shedder Bar Material: X | 583 (22.95) | 595 (23.43) | 620 (24.41) | 582 (22.91) | 601 (23.66) | 621 (24.45) | 633 (24.92) | 585 (23.03) | 593 (23.35) | 621 (24.45) | 633 (24.92) | 640 (25.20) | 650 (25.59) | 646 (25.43) | 665 (26.18) | 684 (26.93) | 709 (27.91) | 645 (25.39) | 645 (25.39) | 655 (25.79) | 662 (26.06) | 684 (26.93) | 709 (27.91) |
| | Shedder Bar Material: B | 590 (23.23) | 602 (23.70) | 627 (24.69) | 589 (23.19) | 608 (23.94) | 628 (24.72) | 640 (25.20) | 592 (23.31) | 600 (23.62) | 628 (24.72) | 640 (25.20) | 647 (25.47) | 657 (25.87) | 653 (25.71) | 672 (26.46) | 691 (27.20) | 716 (28.19) | 652 (25.67) | 652 (25.67) | 662 (26.06) | 669 (26.34) | 691 (27.20) | 716 (28.19) |
| H1 | Shedder Bar Material: X | 339 (13.35) | | | | | | | | | 371 (14.61) | | | | | | | | | | | | | |
| | Shedder Bar Material: B | 346 (13.62) | | | | | | | | | 378 (14.88) | | | | | | | | | | | | | |
| T | 22 (0.87) | 28 (1.10) | 44 (1.73) | 25.4 (1.00) | 36.6 (1.44) | 54.4 (2.14) | 62 (2.44) | 22 (0.87) | 28 (1.10) | 55.7 (2.19) | 63.6 (2.50) | 22 (0.87) | 30 (1.18) | 28.4 (1.12) | 41.1 (1.62) | 62 (2.44) | 69.9 (2.75) | 24 (0.95) | 24 (0.95) | 30 (1.18) | 34 (1.34) | 63.6 (2.50) | 71.4 (2.81) | |
| J | 240 (9.45) | 260 (10.24) | 295 (11.61) | 241.3 (9.50) | 269.7 (10.62) | 292 (11.50) | 317.5 (12.50) | 240 (9.45) | 250 (9.84) | 292 (11.50) | 317.5 (12.50) | 290 (11.42) | 305 (11.75) | 288.5 (11.37) | 330.2 (13.00) | 349.3 (13.75) | 393.7 (15.50) | 295 (11.61) | 295 (11.61) | 310 (12.20) | 320 (12.60) | 349.3 (13.75) | 393.7 (15.50) | |
| N | 8 | 12 | 12 | 8 | 12 | 12 | 12 | 8 | 8 | 12 | 12 | 12 | 12 | 8 | 12 | 12 | 12 | 8 | 12 | 12 | 12 | 12 | 12 | |
| G | 23 (0.91) | 25 (0.98) | 33 (1.30) | 22.4 (0.88) | 22.4 (0.88) | 28.4 (1.12) | 31.8 (1.25) | 22 (0.87) | 26 (1.02) | 28.4 (1.12) | 31.8 (1.25) | 23 (0.91) | 25 (0.98) | 22.4 (0.88) | 25.4 (1.00) | 31.8 (1.25) | 38.1 (1.50) | 22 (0.87) | 22 (0.87) | 26 (1.02) | 26 (1.02) | 31.8 (1.25) | 38.1 (1.50) | |
| WEIGHT kg (lb) | 33.4 (73.65) | 43.4 (95.7) | 76.4 (168.46) | 36.4 (80.26) | 54.4 (119.95) | 84.4 (186.1) | 106 (233.73) | 33.4 (73.65) | 42.9 (94.59) | 90 (198.45) | 107 (235.94) | 45.4 (100.11) | 52.4 (115.54) | 55.4 (122.16) | 80.4 (177.28) | 136 (299.88) | 182 (401.31) | 46.3 (102.09) | 46.3 (102.09) | 53.6 (118.19) | 55.9 (123.26) | 139 (306.5) | 183 (403.52) | |

| TYPE | REMOTE | | | | | | | | | | | |
|----------------|--------------|-------------|---------------|---------------|---------------|--------------|---------------|---------------|---------------|-------------|---------------|---------------|
| | DY250/HT | | | | DY300/HT | | | | DY400/HT | | | |
| MODEL CODE | BJ1 | BJ2 | BA1 BS1 | BA2 BS2 | BJ1 | BJ2 | BA1 BS1 | BA2 BS2 | BJ1 | BJ2 | BA1 BS1 | BA2 BS2 |
| L | 370 (14.57) | | | | 400 (15.75) | | | | 520 (20.47) | | | |
| C | 230.8 (9.09) | | | | 276.2 (10.87) | | | | 354.2 (13.94) | | | |
| D | 400 (15.75) | 430 (16.93) | 486.4 (19.14) | 444.5 (17.50) | 445 (17.52) | 480 (18.90) | 482.6 (19.00) | 520.7 (20.50) | 560 (22.05) | 605 (23.82) | 598.8 (23.5) | 647.7 (25.5) |
| H | 720 (28.35) | 735 (28.94) | 723 (28.46) | 742 (29.21) | 772 (30.39) | 790 (31.10) | 791 (31.14) | 810 (31.89) | 887.5 (34.94) | 910 (35.83) | 906 (35.67) | 931.4 (36.67) |
| H1 | 416 (16.38) | | | | 446 (17.56) | | | | 504 (19.84) | | | |
| T | 24 (0.94) | 34 (1.34) | 30.2 (1.19) | 47.8 (1.88) | 24 (0.94) | 36 (1.42) | 31.8 (1.25) | 50.8 (2.00) | 28 (1.10) | 46 (1.81) | 36.6 (1.44) | 57.2 (2.25) |
| J | 355 (13.98) | 380 (14.96) | 362 (14.25) | 387.4 (15.25) | 400 (15.75) | 430 (16.93) | 431.8 (17.00) | 450.9 (17.75) | 510 (20.08) | 540 (21.26) | 539.8 (21.25) | 571.5 (22.5) |
| N | 12 | 12 | 12 | 16 | 16 | 16 | 12 | 16 | 16 | 16 | 16 | 20 |
| G | 25 (0.98) | 27 (1.06) | 25.4 (1.00) | 28.5 (1.12) | 25 (0.98) | 27 (1.06) | 25.4 (1.00) | 31.8 (1.25) | 27 (1.06) | 33 (1.30) | 28.5 (1.12) | 35.1 (1.38) |
| WEIGHT kg (lb) | 78 (171.99) | 100 (220.5) | 90 (198.45) | 125 (275.63) | 100 (220.5) | 128 (282.24) | 140 (308.7) | 178 (392.49) | 265 (584.2) | 308 (679) | 300 (661.4) | 370 (815.7) |

(Note 1) The flow direction is reversed (right to left when facing onto indicator) in case of code/CRC.

■ Reduced Bore Type (/R1): DY025/R1 to DY150/R1

■ Flange type

Unit : mm
(approx. inch)

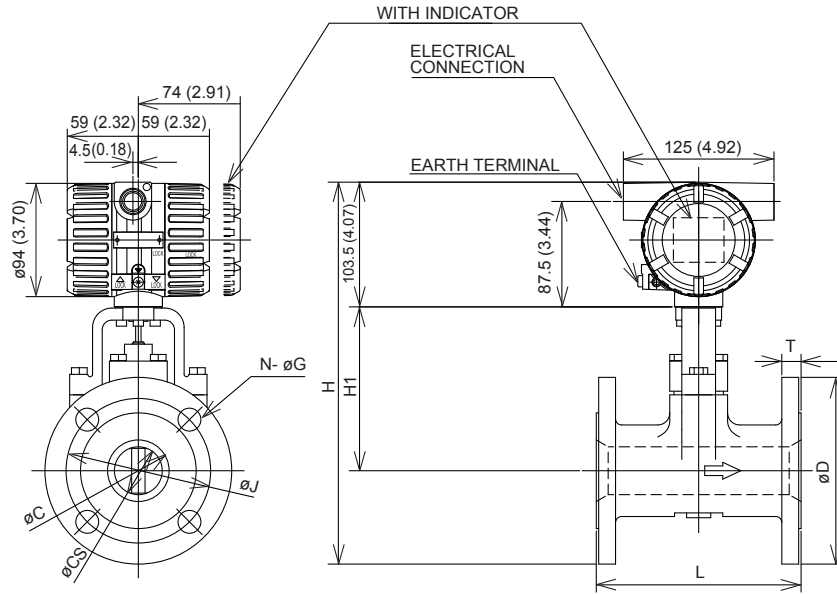

| TYPE | INTEGRAL/REMOTE | | | | | | | | | | | |
|--------------------|-----------------|-------------|---------------|---------------|---------------|---------------|-------------|--------------|-------------|-------------|---------------|--------------|
| MODEL CODE | DY025/R1 | | | | DY040/R1 | | | | DY050/R1 | | | |
| PROCESS CONNECTION | BJ1 | BJ2 | BA1 BS1 | BA2 BS2 | BJ1 | BJ2 | BA1 BS1 | BA2 BS2 | BJ1 | BJ2 | BA1 BS1 | BA2 BS2 |
| L | 150 (5.91) | | | | 150 (5.90) | | | | 170 (6.69) | | | |
| C | 25.7 (1.01) | | | | 39.7 (1.56) | | | | 51.1 (2.01) | | | |
| CS | 14.6 (0.57) | | | | 25.7 (1.01) | | | | 39.7 (1.56) | | | |
| D | 125 (4.92) | 125 (4.92) | 108 (4.25) | 124 (4.88) | 140 (5.51) | 140 (5.51) | 127 (5.00) | 155.4 (6.12) | 155 (6.10) | 155 (6.10) | 152.4 (6.00) | 165.1 (6.50) |
| H | 293 (11.54) | 293 (11.54) | 284.5 (11.20) | 292.5 (11.52) | 302.5 (11.91) | 302.5 (11.91) | 296 (11.65) | 310 (12.20) | 317 (12.48) | 317 (12.48) | 315.5 (12.42) | 322 (12.68) |
| H1 | 127 (5.00) | | | | 129 (5.08) | | | | 136 (5.35) | | | |
| T | 14 (0.55) | 16 (0.63) | 14.2 (0.56) | 17.5 (0.69) | 16 (0.63) | 18 (0.71) | 17.5 (0.69) | 20.6 (0.81) | 16 (0.63) | 18 (0.71) | 19.1 (0.75) | 22.4 (0.88) |
| J | 90 (3.54) | 90 (3.54) | 79.2 (3.12) | 89 (3.50) | 105 (4.13) | 105 (4.13) | 98.6 (3.88) | 114.3 (4.5) | 120 (4.72) | 120 (4.72) | 120.7 (4.75) | 127 (5.00) |
| N | 4 | | | | 4 | | | | 4 | | | |
| G | 19 (0.75) | 19 (0.75) | 15.7 (0.62) | 19 (0.75) | 19 (0.75) | 19 (0.75) | 15.7 (0.62) | 22.4 (0.88) | 19 (0.75) | 19 (0.75) | 19 (0.75) | 19 (0.75) |
| WEIGHT kg (lb) | 6.1 (13.4) | 6.5 (14.3) | 5.5 (12.1) | 7 (15.4) | 9.5 (20.9) | 10.1 (22.3) | 9.4 (20.7) | 12.6 (27.8) | 10.5 (23.1) | 11.1 (24.5) | 11.4 (25.1) | 13.6 (30.0) |

| TYPE | INTEGRAL/REMOTE | | | | | | | | | | | |
|--------------------|-----------------|---------------|--------------|---------------|---------------|-------------|--------------|---------------|---------------|--------------|---------------|---------------|
| MODEL CODE | DY080/R1 | | | | DY100/R1 | | | | DY150/R1 | | | |
| PROCESS CONNECTION | BJ1 | BJ2 | BA1 BS1 | BA2 BS2 | BJ1 | BJ2 | BA1 BS1 | BA2 BS2 | BJ1 | BJ2 | BA1 BS1 | BA2 BS2 |
| L | 200 (7.87) | | | | 220 (8.66) | | | | 270 (10.63) | | | |
| C | 71 (2.80) | | | | 93.8 (3.69) | | | | 138.8 (5.46) | | | |
| CS | 51.1 (2.01) | | | | 71 (2.80) | | | | 93.8 (3.69) | | | |
| D | 185 (7.28) | 200 (7.87) | 190.5 (7.50) | 209.6 (8.25) | 210 (8.27) | 225 (8.86) | 228.6 (9.00) | 254 (10.00) | 280 (11.02) | 305 (12.01) | 279.4 (11.00) | 317.5 (12.50) |
| H | 354 (13.94) | 361.5 (14.23) | 357 (14.06) | 366.5 (14.43) | 383.5 (15.10) | 391 (15.39) | 393 (15.47) | 405.5 (15.97) | 433.5 (17.07) | 446 (17.56) | 433 (17.05) | 452 (17.80) |
| H1 | 158 (6.22) | | | | 175 (6.89) | | | | 190 (7.48) | | | |
| T | 18 (0.71) | 22 (0.87) | 23.9 (0.94) | 28.4 (1.12) | 18 (0.71) | 24 (0.94) | 23.9 (0.94) | 31.8 (1.25) | 22 (0.87) | 28 (1.10) | 25.4 (1.00) | 36.6 (1.44) |
| J | 150 (5.91) | 160 (6.30) | 152.4 (6.00) | 168.2 (6.62) | 175 (6.89) | 185 (7.28) | 190.5 (7.50) | 200.2 (7.88) | 240 (9.45) | 260 (10.24) | 241.3 (9.50) | 269.7 (10.62) |
| N | 8 | | 4 | | 8 | | 8 | | 8 | | 12 | |
| G | 19 (0.75) | 23 (0.91) | 19 (0.75) | 22.4 (0.88) | 19 (0.75) | 23 (0.91) | 19 (0.75) | 22.4 (0.88) | 23 (0.91) | 25 (0.98) | 22.4 (0.88) | 22.4 (0.88) |
| WEIGHT kg (lb) | 18.6 (41.0) | 21.7 (47.8) | 21.9 (48.3) | 26.9 (59.3) | 25 (55.1) | 30 (66.1) | 30.6 (67.5) | 41 (90.4) | 45.9 (101.2) | 56.3 (124.1) | 49.4 (108.9) | 71.7 (158.1) |

(Note 1) Integral weight is the same as Remote.
 (Note 2) In case of with Indicator, add 0.2kg (0.4lb).
 (Note 3) The flow direction is reversed (right to left when facing onto indicator) in case of code/CRC.

- Reduced Bore Type (/R1): DY025/R1 to DY150/R1
- High pressure flange type

Unit : mm
(approx. inch)

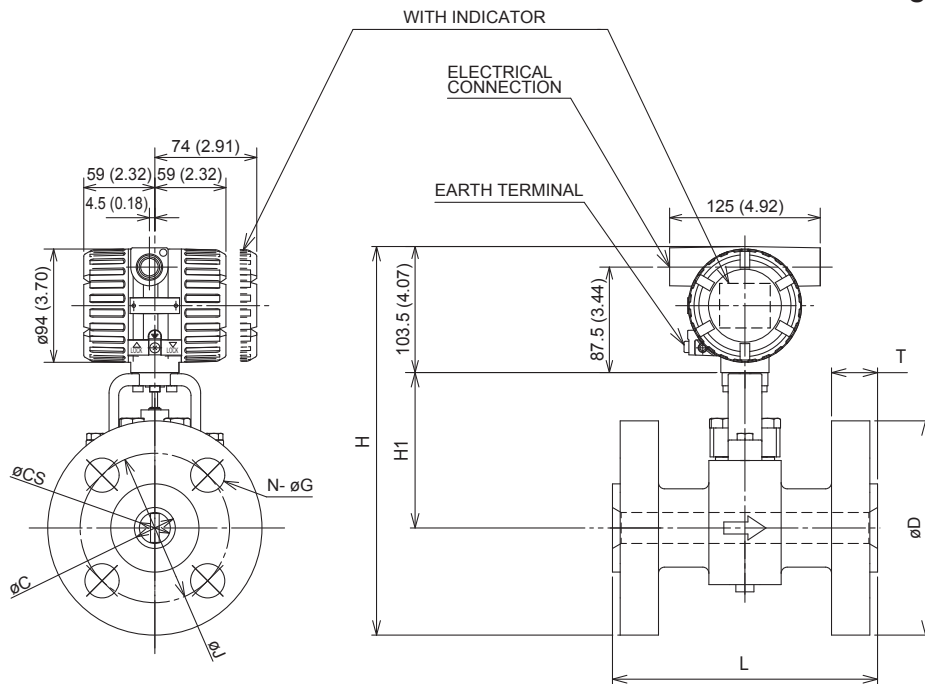

| TYPE | INTEGRAL/REMOTE | | | | | | | | | | | |
|--------------------|-----------------|-------------|---------------|-------------|---------------------------|-------------|---------------------------|--------------|---------------------------|---------------|-------------------------|---------------|
| | DY025/R1 | | DY040/R1 | | DY050/R1 | | DY080/R1 | | DY100/R1 | | DY150/R1 | |
| MODEL CODE | | | | | | | | | | | | |
| PROCESS CONNECTION | BA6 | CA6 | BA6 | CA6 | BA6 | CA6 | BA6 | CA6 | BA6 | CA6 | BA6 | CA6 |
| L | 220 (8.66) | | 220 (8.66) | | 230 (9.06) | | 280 (11.02) | | 300 (11.81) | | 400 (15.75) | |
| C | 20.7 (0.81) | | 34 (1.34) | | 42.8 (1.69) | | 66.6 (2.62) | | 87.3 (3.44) | | 131.8 (5.19) | |
| CS | 14.6 (0.57) | | 25.7 (1.01) | | 39.7 (1.56) | | 51.1 (2.01) | | 71 (2.80) | | 93.8 (3.69) | |
| D | 149.4 (5.88) | | 177.8 (7.00) | | 215.9 (8.50) | | 266.7 (10.50) | | 311.2 (12.25) | | 393.7 (15.50) | |
| H | 305.2 (12.02) | | 321.4 (12.65) | | 347.5 (13.68) | | 394.9 (15.55) | | 434.1 (17.09) | | 490.4 (19.31) | |
| H1 | 127 (5.00) | | 129 (5.08) | | 136 (5.35) | | 158 (6.22) | | 175 (6.89) | | 190 (7.48) | |
| T | 34.9 (1.37) | | 38.2 (1.50) | | 44.5 (1.75) 46.1 (1.81) | | 54.2 (2.13) 55.8 (2.20) | | 60.3 (2.37) 61.8 (2.43) | | 89 (3.50) 92.1 (3.63) | |
| J | 101.6 (4.00) | | 124 (4.88) | | 165.1 (6.50) | | 203.2 (8.00) | | 241.3 (9.50) | | 317.5 (12.50) | |
| N | 4 | | 4 | | 8 | | 8 | | 8 | | 12 | |
| G | 25.4 (1.00) | | 28.4 (1.12) | | 25.4 (1.00) | | 31.8 (1.25) | | 35.1 (1.38) | | 38.1 (1.50) | |
| WEIGHT kg (lb) | 14.4 (31.7) | 15.7 (34.6) | 22.9 (50.5) | 24.7 (54.5) | 37.2 (82.0) | 40.2 (88.6) | 68.5 (151.0) | 72.7 (160.3) | 103.5 (228.2) | 108.5 (239.2) | 229.3 (505.5) | 235.7 (519.6) |

(Note 1) Integral weight is the same as Remote.
 (Note 2) In case of with Indicator, add 0.2kg (0.4lb).
 (Note 3) The flow direction is reversed (right to left when facing onto indicator) in case of code/CRC.

- Reduced Bore Type (/R1): DY200/R1
- Flange type

Unit : mm
(approx. inch)

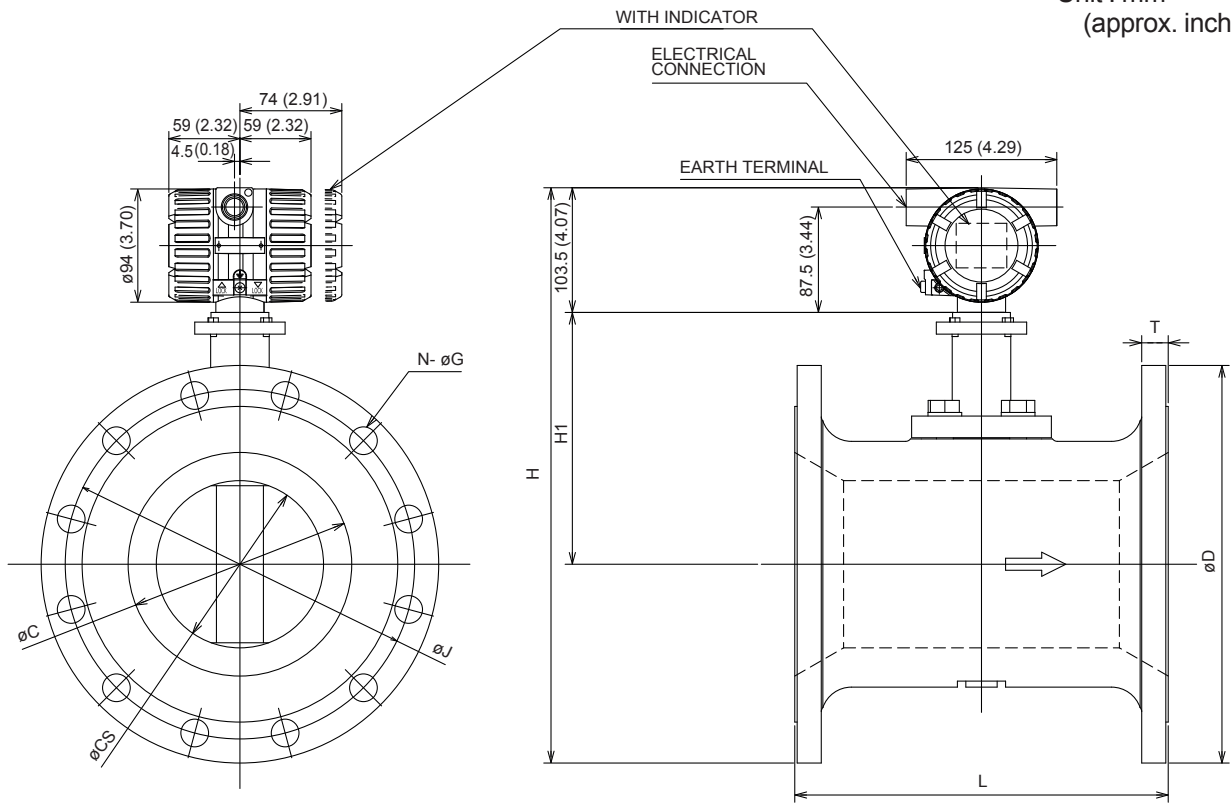

| TYPE | INTEGRAL/REMOTE | | | | |
|--------------------|-------------------------------|---------------|---------------|---------------|-------------|
| MODEL CODE | DY200/R1 | | | | |
| PROCESS CONNECTION | BJ1 | BJ2 | BA1 BS1 | BA2 BS2 | |
| L | 310 (12.20) | | | | |
| C | 185.6 (7.31) | | | | |
| CS | 138.8 (5.46) | | | | |
| D | 330 (12.99) | 350 (13.78) | 342.9 (13.50) | 381 (15.00) | |
| H | Shedder Bar Material: L, E, X | 477.5 (18.80) | 487.5 (19.19) | 484 (19.06) | 503 (19.80) |
| | Shedder Bar Material: B | 484.5 (19.07) | 494.5 (19.47) | 491 (19.33) | 510 (20.08) |
| H1 | Shedder Bar Material: L, E, X | 209 (8.23) | | | |
| | Shedder Bar Material: B | 216 (8.50) | | | |
| T | 22 (0.87) | 30 (1.18) | 28.4 (1.12) | 41.1 (1.62) | |
| J | 290 (11.42) | 305 (12.01) | 298.5 (11.75) | 330.2 (13.00) | |
| N | 12 | 12 | 8 | 12 | |
| G | 23 (0.91) | 25 (0.98) | 22.4 (0.88) | 25.4 (1.00) | |
| WEIGHT kg (lb) | 58.7 (129.4) | 74.1 (163.4) | 70.7 (155.9) | 102.9 (226.9) | |

(Note 1) Integral weight is the same as Remote.
 (Note 2) In case of with Indicator, add 0.2kg (0.4lb).
 (Note 3) The flow direction is reversed (right to left when facing onto indicator) in case of code/CRC.

- High Process Temperature Version Reduced Bore Type (/HT/R1): DY040/HT/R1 to DY150/HT/R1
- Flange type

Unit : mm
(approx. inch)

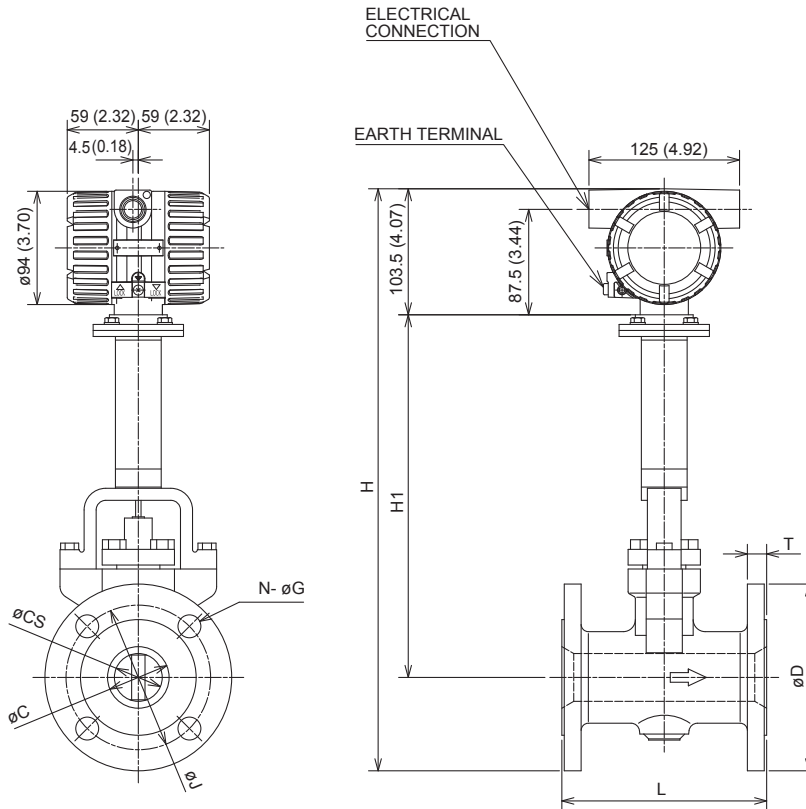

| TYPE | REMOTE | | | | | | | | | | | |
|--------------------|---------------|---------------|-------------|--------------|-------------|-------------|---------------|--------------|-------------|---------------|--------------|---------------|
| MODEL CODE | DY040/HT/R1 | | | | DY050/HT/R1 | | | | DY080/HT/R1 | | | |
| PROCESS CONNECTION | BJ1 | BJ2 | BA1 BS1 | BA2 BS2 | BJ1 | BJ2 | BA1 BS1 | BA2 BS2 | BJ1 | BJ2 | BA1 BS1 | BA2 BS2 |
| L | 150 (5.90) | | | | 170 (6.69) | | | | 200 (7.87) | | | |
| C | 39.7 (1.56) | | | | 51.1 (2.01) | | | | 71 (2.79) | | | |
| CS | 25.7 (1.01) | | | | 39.7 (1.56) | | | | 51.1 (2.01) | | | |
| D | 140 (5.51) | 140 (5.51) | 127 (5.00) | 155.4 (6.12) | 155 (6.10) | 155 (6.10) | 152.4 (6.00) | 165.1 (6.50) | 185 (7.28) | 200 (7.87) | 190.5 (7.50) | 209.6 (8.25) |
| H | 445.5 (17.54) | 445.5 (17.54) | 439 (17.28) | 453 (17.83) | 460 (18.11) | 460 (18.11) | 458.5 (18.05) | 465 (18.30) | 497 (19.57) | 504.5 (19.86) | 500 (19.68) | 509.5 (20.05) |
| H1 | 272 (10.71) | | | | 279 (10.98) | | | | 301 (11.85) | | | |
| T | 16 (0.63) | 18 (0.71) | 17.5 (0.69) | 20.6 (0.81) | 16 (0.63) | 18 (0.71) | 19.1 (0.75) | 22.4 (0.88) | 18 (0.71) | 22 (0.87) | 23.9 (0.94) | 28.4 (1.11) |
| J | 105 (4.13) | 105 (4.13) | 98.6 (3.88) | 114.3 (4.50) | 120 (4.72) | 120 (4.72) | 120.7 (4.75) | 127 (5.00) | 150 (5.91) | 160 (6.30) | 152.4 (6.00) | 168.2 (6.62) |
| N | 4 | | | | 4 | 8 | 4 | 8 | 8 | 8 | 4 | 8 |
| G | 19 (0.75) | 19 (0.75) | 15.7 (0.62) | 22.4 (0.88) | 19 (0.75) | 19 (0.75) | 19 (0.75) | 19 (0.75) | 19 (0.75) | 23 (0.91) | 19 (0.75) | 22.4 (0.88) |
| WEIGHT kg (lb) | 10 (22.0) | 10.5 (23.1) | 9.8 (21.6) | 13 (28.7) | 10.9 (24.0) | 11.5 (25.4) | 11.8 (26.0) | 14 (30.9) | 19 (41.9) | 22.1 (48.7) | 22.3 (49.2) | 27.3 (60.2) |

| TYPE | REMOTE | | | | | | | |
|--------------------|---------------|-------------|--------------|---------------|---------------|--------------|---------------|---------------|
| MODEL CODE | DY100/HT/R1 | | | | DY150/HT/R1 | | | |
| PROCESS CONNECTION | BJ1 | BJ2 | BA1 BS1 | BA2 BS2 | BJ1 | BJ2 | BA1 BS1 | BA2 BS2 |
| L | 220 (8.66) | | | | 270 (10.63) | | | |
| C | 93.8 (3.69) | | | | 138.8 (5.46) | | | |
| CS | 71 (2.79) | | | | 93.8 (3.69) | | | |
| D | 210 (8.27) | 225 (8.86) | 228.6 (9.00) | 254 (10.00) | 280 (11.02) | 305 (12.01) | 279.4 (11.00) | 317.5 (12.50) |
| H | 526.5 (20.73) | 534 (21.02) | 536 (21.10) | 548.5 (21.59) | 576.5 (22.70) | 589 (23.19) | 576 (22.68) | 595.5 (23.44) |
| H1 | 318 (12.52) | | | | 333 (13.11) | | | |
| T | 18 (0.71) | 24 (0.94) | 23.9 (0.94) | 31.8 (1.25) | 22 (0.87) | 28 (1.10) | 25.4 (1.00) | 36.6 (1.44) |
| J | 175 (6.89) | 185 (7.28) | 190.5 (7.50) | 200.2 (7.88) | 240 (9.45) | 260 (10.24) | 241.3 (9.50) | 269.7 (10.62) |
| N | 8 | | | | 8 | 12 | 8 | 12 |
| G | 19 (0.75) | 23 (0.91) | 19 (0.75) | 22.4 (0.88) | 23 (0.91) | 25 (0.98) | 22.4 (0.88) | 22.4 (0.88) |
| WEIGHT kg (lb) | 25.4 (56.0) | 30.4 (67.0) | 31 (68.3) | 41.4 (91.3) | 45.9 (101.2) | 56.3 (124.1) | 49.4 (108.9) | 71.7 (158.1) |

(Note 1) The flow direction is reversed (right to left when facing onto indicator) in case of code/CRC.

■ High Process Temperature Version Reduced Bore Type (/HT/R1): DY200/HT/R1

■ Flange type

Unit : mm
(approx. inch)

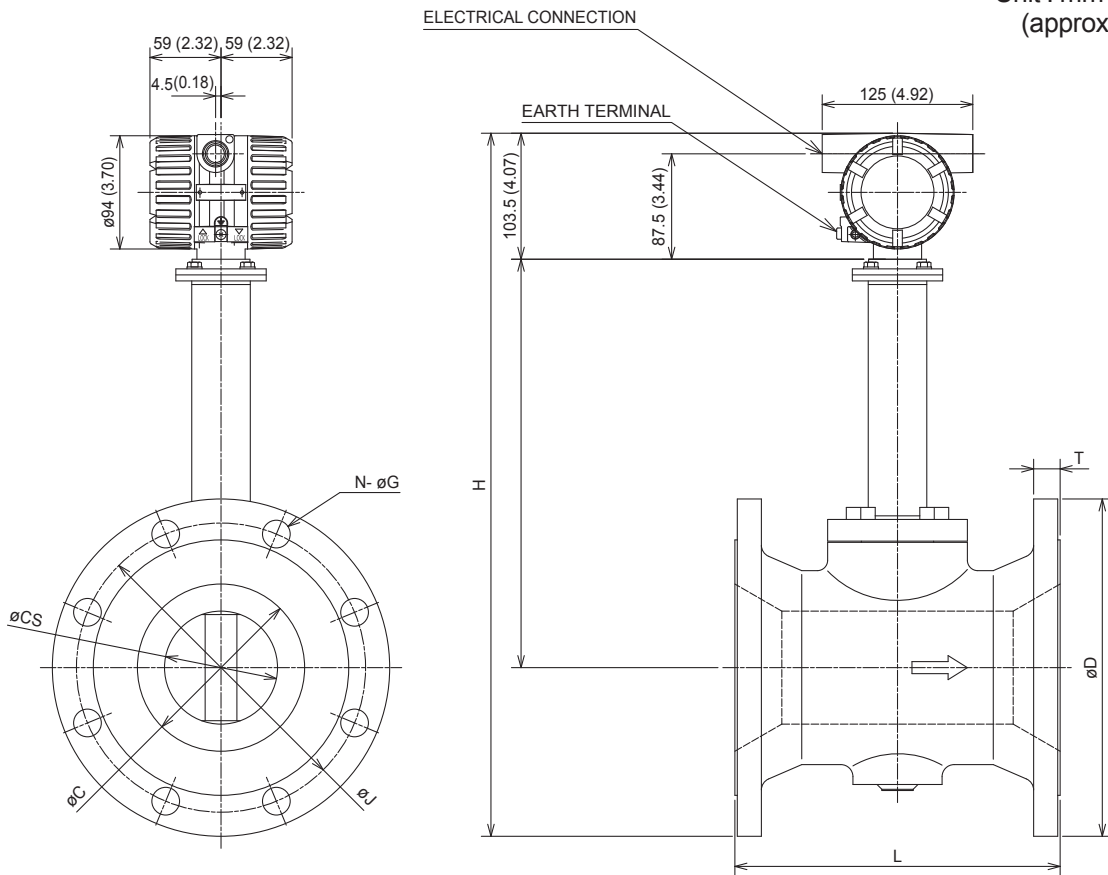

| TYPE | | REMOTE | | | |
|--------------------|-------------------------|---------------|---------------|---------------|---------------|
| MODEL CODE | | DY200/HT/R1 | | | |
| PROCESS CONNECTION | | BJ1 | BJ2 | BA1 BS1 | BA2 BS2 |
| L | | 310 (12.20) | | | |
| C | | 185.6 (7.31) | | | |
| CS | | 138.8 (5.46) | | | |
| D | | 330 (12.99) | 350 (13.78) | 342.9 (13.5) | 381 (15.0) |
| H | Shedder Bar Material: X | 607.5 (23.92) | 617.5 (24.31) | 614 (24.17) | 633 (24.92) |
| | Shedder Bar Material: B | 614.5 (24.19) | 624.5 (24.59) | 621 (24.45) | 640 (25.20) |
| H1 | Shedder Bar Material: X | 339 (13.35) | | | |
| | Shedder Bar Material: B | 346 (13.62) | | | |
| T | | 22 (0.87) | 30 (1.18) | 28.4 (1.11) | 41.1 (1.62) |
| J | | 290 (11.42) | 305 (12.01) | 298.5 (11.75) | 330.2 (13.00) |
| N | | 12 | 12 | 8 | 12 |
| G | | 23 (0.91) | 25 (0.98) | 22.4 (0.88) | 25.4 (1.00) |
| WEIGHT kg (lb) | | 58.7 (129.4) | 74.1 (163.4) | 70.7 (155.9) | 102.9 (226.9) |

(Note 1) The flow direction is reversed (right to left when facing onto indicator) in case of code/CRC.

■ Reduced Bore Type (/R2): DY040/R2 to DY200/R2

■ Flange type

Unit : mm
(approx. inch)

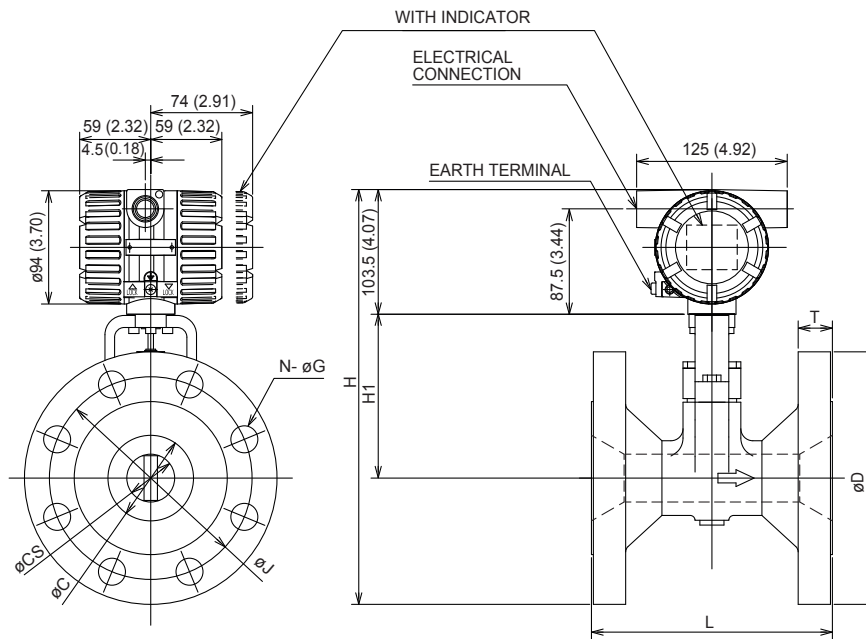

| TYPE | INTEGRAL/REMOTE | | | | | | | | | | | | | | | | | | | | | | | |
|----------------|-----------------|---------------|-------------|---------------|-------------|-------------|---------------|---------------|-------------|---------------|---------------|---------------|---------------|-------------|---------------|---------------|---------------|--------------|---------------|---------------|---------------|---------------|---------------|---------------|
| | DY040/R2 | | | | DY050/R2 | | | | DY080/R2 | | | | DY100 /R2 | | | | DY150/R2 | | | | DY200/R2 | | | |
| MODEL CODE | BJ1 | BJ2 | BA1 BS1 | BA2 BS2 | BJ1 | BJ2 | BA1 BS1 | BA2 BS2 | BJ1 | BJ2 | BA1 BS1 | BA2 BS2 | BJ1 | BJ2 | BA1 BS1 | BA2 BS2 | BJ1 | BJ2 | BA1 BS1 | BA2 BS2 | BJ1 | BJ2 | BA1 BS1 | BA2 BS2 |
| L | 150 (5.90) | | | | 170 (6.69) | | | | 200 (7.87) | | | | 220 (8.66) | | | | 270 (10.63) | | | | 310 (12.20) | | | |
| C | 39.7 (1.56) | | | | 51.1 (2.01) | | | | 71 (2.79) | | | | 93.8 (3.69) | | | | 138.8 (5.46) | | | | 185.6 (7.30) | | | |
| CS | 14.6 (0.57) | | | | 25.7 (1.01) | | | | 39.7 (1.56) | | | | 51.1 (2.01) | | | | 71 (2.79) | | | | 93.8 (3.69) | | | |
| D | 140 (5.51) | 140 (5.51) | 127 (4.94) | 155.4 (6.12) | 155 (6.10) | 155 (6.10) | 152.4 (6.00) | 165.1 (6.50) | 185 (7.28) | 200 (7.87) | 190.5 (7.50) | 209.6 (8.25) | 210 (8.27) | 225 (8.86) | 228.6 (9.00) | 254 (10.00) | 280 (11.02) | 305 (12.01) | 279.4 (11.00) | 317.5 (12.50) | 330 (12.99) | 350 (13.78) | 342.9 (13.50) | 381 (15.00) |
| H | 300.5 (11.83) | 300.5 (11.83) | 294 (11.57) | 308.2 (12.13) | 310 (12.20) | 310 (12.20) | 308.7 (12.15) | 315.1 (12.40) | 332 (13.07) | 339.5 (13.37) | 334.8 (13.18) | 344.3 (13.55) | 366.5 (14.43) | 374 (14.72) | 375.8 (14.80) | 388.5 (15.30) | 418.5 (16.48) | 431 (16.97) | 418.2 (16.46) | 437.3 (17.22) | 458.5 (18.05) | 468.5 (18.44) | 465 (18.31) | 484 (19.06) |
| H1 | 127 (4.94) | | | | 129 (5.07) | | | | 136 (5.35) | | | | 158 (6.22) | | | | 175 (6.89) | | | | 190 (7.48) | | | |
| T | 16 (0.63) | 18 (0.71) | 17.5 (0.69) | 20.6 (0.81) | 16 (0.63) | 18 (0.71) | 19.1 (0.75) | 22.4 (0.88) | 18 (0.71) | 22 (0.87) | 23.9 (0.94) | 28.4 (1.11) | 18 (0.71) | 24 (0.94) | 23.9 (0.94) | 31.8 (1.25) | 22 (0.87) | 28 (1.10) | 25.4 (1.00) | 36.6 (1.44) | 22 (0.87) | 30 (1.18) | 28.4 (1.11) | 41.1 (1.62) |
| J | 105 (4.13) | 105 (4.13) | 98.6 (3.88) | 114.3 (4.50) | 120 (4.72) | 120 (4.72) | 120.7 (4.75) | 127 (5.00) | 150 (5.91) | 160 (6.30) | 152.4 (6.00) | 168.2 (6.62) | 175 (6.89) | 185 (7.28) | 190.5 (7.50) | 200.2 (7.88) | 240 (9.45) | 260 (10.24) | 241.3 (9.50) | 269.7 (10.62) | 290 (11.42) | 305 (12.01) | 298.5 (11.75) | 330.2 (13.00) |
| N | 4 | | | | 4 | 8 | 4 | 8 | 8 | 8 | 4 | 8 | 8 | | | | 8 | 12 | 8 | 12 | 12 | 12 | 8 | 12 |
| G | 19 (0.75) | 19 (0.75) | 15.7 (0.62) | 22.4 (0.88) | 19 (0.75) | | | | 19 (0.75) | 23 (0.91) | 19 (0.75) | 22.4 (0.88) | 19 (0.75) | 23 (0.91) | 19 (0.75) | 22.4 (0.88) | 23 (0.91) | 25 (0.98) | 22.4 (0.88) | 22.4 (0.88) | 23 (0.91) | 25 (0.98) | 22.4 (0.88) | 25.4 (1.00) |
| WEIGHT kg (lb) | 7.7 (17.0) | 7.9 (17.4) | 7.6 (16.8) | 8.8 (19.4) | 10 (22.0) | 10.5 (23.1) | 10.6 (23.4) | 12.1 (26.7) | 13.6 (30.0) | 16.2 (35.7) | 16.2 (35.7) | 20 (44.1) | 20.9 (46.1) | 24.9 (54.9) | 25.5 (56.2) | 34 (75.0) | 40.3 (88.8) | 50.3 (110.9) | 43.3 (95.5) | 61.3 (135.1) | 61.9 (136.5) | 68.9 (151.9) | 71.9 (158.5) | 96.9 (213.6) |

(Note 1) Integral weight is the same as Remote.
 (Note 2) In case of with Indicator, add 0.2kg (0.4lb).
 (Note 3) The flow direction is reversed (right to left when facing onto indicator) in case of code/CRC.

■ High Process Temperature Version Reduced Bore Type (/HT/R2): DY050/HT/R2 to DY200/HT/R2

Unit : mm
(approx. inch)

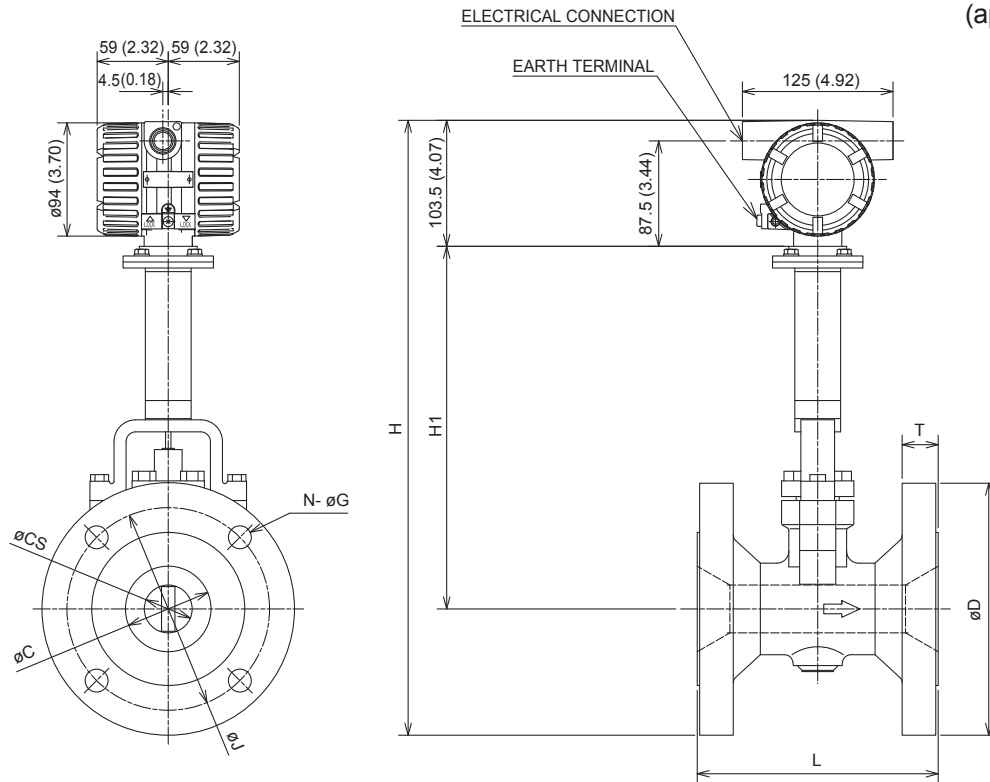

| TYPE | REMOTE | | | | | | | | | | | | | | | | | | | | | | | |
|----------------|-------------|-------------|---------------|---------------|-------------|---------------|---------------|---------------|---------------|-------------|---------------|---------------|---------------|--------------|---------------|---------------|---------------|---------------|---------------|---------------|-------------|--|---------|--|
| | DY050/HT/R2 | | | | DY080/HT/R2 | | | | DY100 /HT/R2 | | | | DY150/HT/R2 | | | | DY200/HT/R2 | | | | | | | |
| MODEL CODE | BJ1 | | BJ2 | | BA1 BS1 | | BA2 BS2 | | BJ1 | | BJ2 | | BA1 BS1 | | BA2 BS2 | | BJ1 | | BJ2 | | BA1 BS1 | | BA2 BS2 | |
| L | 170 (6.69) | | | | 200 (7.87) | | | | 220 (8.66) | | | | 270 (10.63) | | | | 310 (12.20) | | | | | | | |
| C | 51.1 (2.01) | | | | 71 (2.79) | | | | 93.8 (3.69) | | | | 138.8 (5.46) | | | | 185.6 (7.30) | | | | | | | |
| CS | 25.7 (1.01) | | | | 39.7 (1.56) | | | | 51.1 (2.01) | | | | 71 (2.79) | | | | 93.8 (3.69) | | | | | | | |
| D | 155 (6.10) | 155 (6.10) | 152.4 (6.00) | 165.1 (6.50) | 185 (7.28) | 200 (7.87) | 190.5 (7.50) | 209.6 (8.25) | 210 (8.27) | 225 (8.86) | 228.6 (9.00) | 254 (10.00) | 280 (11.02) | 305 (12.01) | 279.4 (11.00) | 317.5 (12.5) | 330 (12.99) | 350 (13.78) | 342.9 (13.5) | 381 (15.00) | | | | |
| H | 453 (17.95) | 453 (17.95) | 451.7 (17.78) | 458.1 (18.03) | 475 (18.70) | 482.5 (19.00) | 477.8 (18.81) | 487.3 (19.19) | 509.5 (20.06) | 517 (20.35) | 518.8 (20.43) | 531.5 (20.93) | 561.5 (22.11) | 574 (22.60) | 561.2 (22.09) | 580.3 (22.85) | 601.5 (23.68) | 611.5 (24.07) | 608 (23.94) | 627 (24.69) | | | | |
| H1 | 272 (10.71) | | | | 279 (10.98) | | | | 301 (11.85) | | | | 318 (12.52) | | | | 333 (13.11) | | | | | | | |
| T | 16 (0.63) | 18 (0.71) | 19.1 (0.75) | 22.4 (0.88) | 18 (0.71) | 22 (0.87) | 23.9 (0.94) | 28.4 (1.11) | 18 (0.71) | 24 (0.94) | 23.9 (0.94) | 31.8 (1.25) | 22 (0.87) | 28 (1.10) | 25.4 (1.0) | 36.6 (1.44) | 22 (0.87) | 30 (1.18) | 28.4 (1.11) | 41.1 (1.62) | | | | |
| J | 120 (4.72) | 120 (4.72) | 120.7 (4.75) | 127 (5.00) | 150 (5.91) | 160 (6.30) | 152.4 (6.00) | 168.2 (6.62) | 175 (6.89) | 185 (7.28) | 190.5 (7.50) | 200.2 (7.88) | 240 (9.45) | 260 (10.24) | 241.3 (9.50) | 269.7 (10.62) | 290 (11.42) | 305 (12.01) | 298.5 (11.75) | 330.2 (13.00) | | | | |
| N | 4 | 8 | 4 | 8 | 8 | 8 | 4 | 8 | 8 | | | | 8 | 12 | 8 | 12 | 12 | 12 | 8 | 12 | | | | |
| G | 19 (0.75) | | | | 19 (0.75) | 23 (0.91) | 19 (0.75) | 22.4 (0.88) | 19 (0.75) | 23 (0.91) | 19 (0.75) | 22.4 (0.88) | 23 (0.91) | 25 (0.98) | 22.4 (0.88) | 22.4 (0.88) | 23 (0.91) | 25 (0.98) | 22.4 (0.88) | 25 (0.98) | 22.4 (0.88) | | | |
| WEIGHT kg (lb) | 10.4 (23.0) | 10.9 (24.0) | 11 (24.3) | 12.5 (27.6) | 14 (30.9) | 16.6 (36.6) | 16.6 (36.6) | 20.4 (45.0) | 21.3 (47.0) | 25.3 (55.8) | 25.9 (57.1) | 34.4 (75.8) | 40.3 (88.8) | 50.3 (110.9) | 43.3 (95.5) | 61.3 (135.1) | 61.9 (136.5) | 68.9 (151.9) | 71.9 (158.5) | 96.9 (213.6) | | | | |

(Note 1) The flow direction is reversed (right to left when facing onto indicator) in case of code/CRC.

■ Stainless Steel Housing: DY015/E1 to DY100/E1

■ Wafer Type

Unit : mm
(approx. inch)

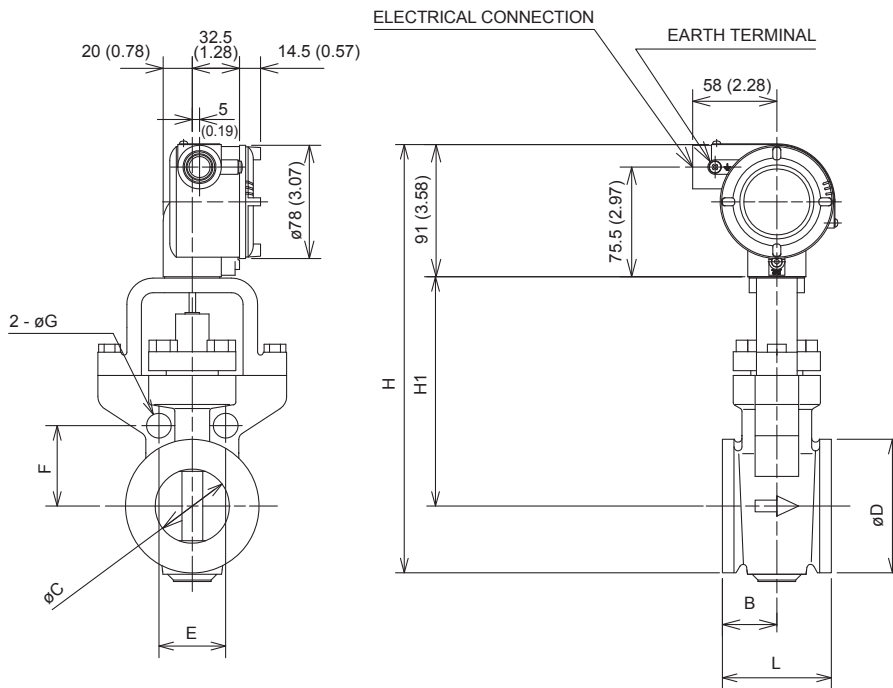

| TYPE | REMOTE | | | | | | | | | | | | | | | | | | | | |
|--------------------|--------------|-------------|-------------|-------------|-------------|-------------|--------------|-------------|-------------|-------------|-----------|-------------|---------------|-------------|-------------|-------------|-------------|-------------|-------------|-------------|-------------|
| MODEL CODE | DY015/E1 | | | | | | DY025/E1 | | | | | | DY040/E1 | | | | | | | | |
| PROCESS CONNECTION | AJ1 | AJ2 | AJ4 | AA1 | AA2 | AA4 | AD1 to AD4 | AJ1 | AJ2 | AJ4 | AA1 | AA2 | AA4 | AD1 to AD4 | AJ1 | AJ2 | AJ4 | AA1 | AA2 | AA4 | AD1 to AD4 |
| L | 70 (2.76) | | | | | | 70 (2.76) | | | | | | 70 (2.76) | | | | | | | | |
| B | 35 (1.38) | | | | | | 35 (1.38) | | | | | | 35 (1.38) | | | | | | | | |
| C | 14.6 (0.57) | | | | | | 25.7 (1.01) | | | | | | 39.7 (1.56) | | | | | | | | |
| D | 35.1 (1.38) | | | | | | 50.8 (2.00) | | | | | | 73 (2.87) | | | | | | | | |
| H | 235.5 (9.27) | | | | | | 245.4 (9.66) | | | | | | 263.5 (10.37) | | | | | | | | |
| H1 | 127 (5.00) | | | | | | 129 (5.08) | | | | | | 136 (5.35) | | | | | | | | |
| E | 49.5 (1.95) | 49.5 (1.95) | 56.6 (2.23) | 42.7 (1.68) | 47.1 (1.85) | 47.1 (1.85) | 46 (1.81) | 63.6 (2.50) | 63.6 (2.50) | 67.2 (2.65) | 56 (2.20) | 62.9 (2.48) | 62.9 (2.48) | 60.1 (2.37) | 74.2 (2.92) | 74.2 (2.92) | 84.9 (3.34) | 69.7 (2.74) | 80.8 (3.18) | 80.8 (3.18) | 77.8 (3.06) |
| F | 24.7 (0.97) | 24.7 (0.97) | 28.3 (1.11) | 21.4 (0.84) | 23.5 (0.93) | 23.5 (0.93) | 23 (0.91) | 31.8 (1.25) | 31.8 (1.25) | 33.6 (1.32) | 28 (1.10) | 31.4 (1.24) | 31.4 (1.24) | 30.1 (1.19) | 37.1 (1.46) | 37.1 (1.46) | 42.4 (1.67) | 34.8 (1.37) | 40.4 (1.59) | 40.4 (1.59) | 38.9 (1.53) |
| G | 13 (0.51) | 13 (0.51) | 17 (0.67) | 14 (0.55) | 14 (0.55) | 14 (0.55) | 13 (0.51) | 17 (0.67) | 17 (0.67) | 17 (0.67) | 14 (0.55) | 17 (0.67) | 17 (0.67) | 13 (0.51) | 17 (0.67) | 17 (0.67) | 21 (0.83) | 14 (0.55) | 20 (0.79) | 20 (0.79) | 17 (0.67) |
| WEIGHT kg (lb) | 2.9 (6.4) | | | | | | 3.8 (8.4) | | | | | | 4.4 (9.7) | | | | | | | | |

| TYPE | REMOTE | | | | | | | | | | | | | | | | | | | | | | |
|--------------------|-------------|-------------|-------------|-------------|-------------|-------------|---------------|-------------|-------------|-------------|-------------|-------------|---------------|-------------|-------------|-------------|-------------|-------------|-------------|-----------|-----|---------|---------|
| MODEL CODE | DY050/E1 | | | | | | DY080/E1 | | | | | | DY100/E1 | | | | | | | | | | |
| PROCESS CONNECTION | AJ1 | AJ2 | AJ4 | AA1 | AA2 | AA4 | AD1 to AD4 | AJ1 | AJ2 | AJ4 | AA1 | AA2 | AA4 | AD1 AD2 | AD3 AD4 | AJ1 | AJ2 | AJ4 | AA1 | AA2 | AA4 | AD1 AD2 | AD3 AD4 |
| L | 75 (2.95) | | | | | | 100 (3.94) | | | | | | 120 (4.72) | | | | | | | | | | |
| B | 37.5 (1.48) | | | | | | 40 (1.57) | | | | | | 50 (1.97) | | | | | | | | | | |
| C | 51.1 (2.01) | | | | | | 71 (2.80) | | | | | | 93.8 (3.69) | | | | | | | | | | |
| D | 92 (3.62) | | | | | | 127 (5.00) | | | | | | 157.2 (6.19) | | | | | | | | | | |
| H | 295 (11.61) | | | | | | 329.5 (12.97) | | | | | | 359.6 (14.16) | | | | | | | | | | |
| H1 | 158 (6.22) | | | | | | 175 (6.89) | | | | | | 190 (7.48) | | | | | | | | | | |
| E | 45.9 (1.81) | 49.8 (1.96) | 48.6 (1.91) | 48.6 (1.91) | 57.4 (2.26) | 61.2 (2.41) | 65.1 (2.56) | 64.4 (2.54) | 64.4 (2.54) | 61.2 (2.41) | 61.2 (2.41) | 67 (2.64) | 70.8 (2.79) | 78.5 (3.09) | 72.9 (2.87) | 76.6 (3.02) | 82.6 (3.25) | 68.9 (2.71) | 72.7 (2.86) | | | | |
| F | 55.4 (2.18) | 60.1 (2.37) | 58.7 (2.31) | 58.7 (2.31) | 69.3 (2.73) | 73.9 (2.91) | 78.5 (3.09) | 77.7 (3.06) | 77.7 (3.06) | 73.9 (2.91) | 73.9 (2.91) | 80.8 (3.18) | 85.5 (3.37) | 94.7 (3.73) | 88 (3.46) | 92.5 (3.64) | 99.7 (3.93) | 83.1 (3.27) | 87.8 (3.46) | | | | |
| G | 17 (0.67) | 17 (0.67) | 17 (0.67) | 17 (0.67) | 17 (0.67) | 21 (0.83) | 21 (0.83) | 20 (0.79) | 20 (0.79) | 17 (0.67) | 17 (0.67) | 17 (0.67) | 17 (0.67) | 21 (0.83) | 23 (0.91) | 17 (0.67) | 20 (0.79) | 23 (0.91) | 17 (0.67) | 21 (0.83) | | | |
| WEIGHT kg (lb) | 6.1 (13.4) | | | | | | 9.5 (20.9) | | | | | | 12.9 (28.4) | | | | | | | | | | |

(Note 1) The holes are not provided.
(Note 2) The flow direction is reversed (right to left when facing onto indicator) in case of code/CRC.

■ Stainless Steel Housing: DY015/E1 to DY100/E1

■ Flange type

Unit : mm
(approx. inch)

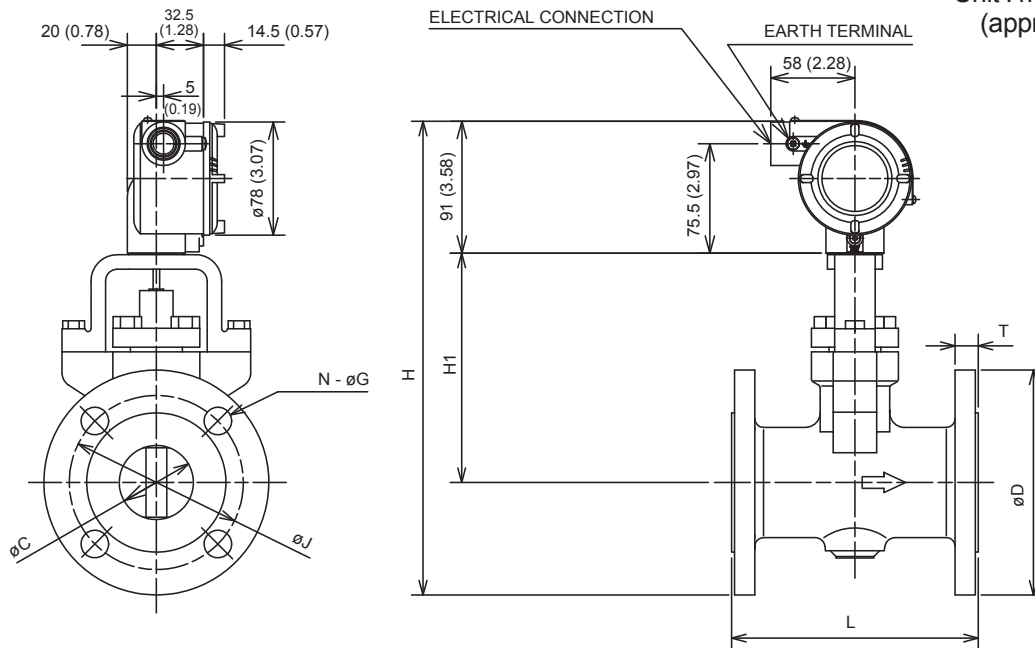

| TYPE | REMOTE | | | | | | | | | | | | | | | | | | | |
|--------------------|---------------|---------------|---------------|---------------|---------------|---------------|---------------|-----------------------|---------------|---------------|---------------|---------------|-------------|-------------|-------------|-------------|---------------|-----------------------|-------------|---------------|
| MODEL CODE | DY015E1 | | | | | | | | DY025E1 | | | | | | | | | | | |
| PROCESS CONNECTION | BJ1 | BJ2 | BJ4 | BA1 BS1 | BA2 BS2 | BA4 BS4 | BA5 BS5 | BD1 to BD4 FD1 to FD4 | CA4 | CA5 | BJ1 | BJ2 | BJ4 | BA1 BS1 | BA2 BS2 | BA4 BS4 | BA5 BS5 | BD1 to BD4 FD1 to FD4 | CA4 | CA5 |
| L | 130 (5.12) | | | | | | | | 150 (5.91) | | | | | | | | | | | |
| C | 25.7 (1.01) | | | | | | | | | | | | | | | | | | | |
| D | 95 (3.74) | 95 (3.74) | 115 (4.53) | 88.9 (3.5) | 95.3 (3.75) | 95.3 (3.75) | 120.7 (4.75) | 95 (3.74) | 95.3 (3.75) | 120.7 (4.75) | 125 (4.92) | 125 (4.92) | 130 (5.12) | 108 (4.25) | 124 (4.88) | 124 (4.88) | 149.4 (5.87) | 115 (4.53) | 124 (4.88) | 149.4 (5.87) |
| H | 265.5 (10.45) | 265.5 (10.45) | 275.5 (10.85) | 262.5 (10.33) | 265.5 (10.45) | 265.5 (10.45) | 278.5 (10.96) | 265.5 (10.45) | 265.5 (10.45) | 278.5 (10.96) | 282.5 (11.12) | 282.5 (11.12) | 285 (11.22) | 274 (10.79) | 282 (11.10) | 282 (11.10) | 294.7 (11.61) | 277.5 (10.93) | 282 (11.10) | 294.7 (11.61) |
| H1 | 127 (5) | | | | | | | | | | | | | | | | | | | |
| T | 12 (0.47) | 14 (0.55) | 20 (0.79) | 11.2 (0.44) | 14.2 (0.56) | 21 (0.83) | 28.8 (1.13) | 16 (0.63) | 19.9 (0.78) | 28.8 (1.13) | 14 (0.55) | 16 (0.63) | 22 (0.87) | 14.2 (0.56) | 17.5 (0.69) | 24 (0.95) | 34.9 (1.37) | 18 (0.71) | 24 (0.95) | 34.9 (1.37) |
| J | 70 (2.76) | 80 (3.15) | 80 (3.15) | 60.5 (2.39) | 66.5 (2.62) | 66.5 (2.62) | 82.6 (3.25) | 65 (2.56) | 66.5 (2.62) | 82.6 (3.25) | 90 (3.54) | 90 (3.54) | 95 (3.74) | 79.2 (3.12) | 89 (3.51) | 89 (3.51) | 101.6 (4.00) | 85 (3.35) | 89 (3.51) | 101.6 (4.00) |
| N | 4 | | | | | | | | | | | | | | | | | | | |
| G | 15 (0.59) | 15 (0.59) | 19 (0.75) | 15.7 (0.62) | 15.7 (0.62) | 15.7 (0.62) | 22.4 (0.88) | 14 (0.55) | 15.7 (0.62) | 22.4 (0.88) | 19 (0.75) | 19 (0.75) | 19 (0.75) | 15.7 (0.62) | 19 (0.75) | 19 (0.75) | 25.4 (1.00) | 14 (0.55) | 19 (0.75) | 25.4 (1.00) |
| WEIGHT kg (lb) | 4.3 (9.5) | 4.4 (9.7) | 5.9 (13.2) | 4.2 (9.3) | 4.4 (9.7) | 4.7 (10.4) | 6.8 (15.0) | 4.3 (9.5) | 4.6 (10.1) | 6.8 (15.2) | 7 (15.4) | 7.2 (15.9) | 8.7 (19.2) | 6.7 (14.8) | 7.3 (16.1) | 7.8 (17.2) | 11.2 (24.7) | 7 (15.4) | 8 (17.6) | 11.5 (25.4) |

| TYPE | REMOTE | | | | | | | | | | | | | | | | | | | |
|--------------------|-------------|-------------|-------------|---------------|---------------|---------------|---------------|-----------------------|---------------|---------------|---------------|---------------|---------------|---------------|---------------|---------------|--------------|-----------------------|---------------|--------------|
| MODEL CODE | DY040E1 | | | | | | | | DY050E1 | | | | | | | | | | | |
| PROCESS CONNECTION | BJ1 | BJ2 | BJ4 | BA1 BS1 | BA2 BS2 | BA4 BS4 | BA5 BS5 | BD1 to BD4 FD1 to FD4 | CA4 | CA5 | BJ1 | BJ2 | BJ4 | BA1 BS1 | BA2 BS2 | BA4 BS4 | BA5 BS5 | BD1 to BD4 FD1 to FD4 | CA4 | CA5 |
| L | 150 (5.90) | | | | | | | | 170 (6.69) | | | | | | | | | | | |
| C | 39.7 (1.56) | | | | | | | | | | | | | | | | | | | |
| D | 140 (5.51) | 140 (5.51) | 160 (6.30) | 127 (5.00) | 155.4 (6.12) | 155.4 (6.12) | 177.8 (7.00) | 150 (5.90) | 155.4 (6.12) | 177.8 (7.00) | 155 (6.10) | 155 (6.10) | 165 (6.50) | 152.4 (6.00) | 165.1 (6.50) | 165.1 (6.50) | 215.9 (8.50) | 165 (6.50) | 165.1 (6.50) | 215.9 (8.50) |
| H | 297 (11.69) | 297 (11.69) | 307 (12.09) | 290.5 (11.44) | 304.7 (12.00) | 304.7 (12.00) | 315.9 (12.44) | 302 (11.89) | 304.7 (12.00) | 315.9 (12.44) | 326.5 (12.85) | 326.5 (12.85) | 331.5 (13.05) | 325.2 (12.81) | 331.5 (13.05) | 331.5 (13.05) | 357 (14.06) | 331.5 (13.05) | 331.5 (13.05) | 357 (14.06) |
| H1 | 136 (5.36) | | | | | | | | | | | | | | | | | | | |
| T | 16 (0.63) | 18 (0.71) | 26 (1.02) | 17.5 (0.69) | 20.6 (0.81) | 28.8 (1.13) | 38.2 (1.51) | 18 (0.71) | 28.8 (1.13) | 38.2 (1.51) | 16 (0.63) | 18 (0.71) | 26 (1.02) | 19.1 (0.75) | 22.4 (0.88) | 31.8 (1.25) | 44.5 (1.75) | 20 (0.79) | 33.3 (1.31) | 46 (1.81) |
| J | 105 (4.13) | 105 (4.13) | 120 (4.72) | 98.6 (3.88) | 114.3 (4.50) | 114.3 (4.50) | 124 (4.88) | 110 (4.33) | 114.3 (4.50) | 124 (4.88) | 120 (4.72) | 120 (4.72) | 130 (5.12) | 120.7 (4.75) | 127 (5.00) | 127 (5.00) | 165.1 (6.50) | 125 (4.92) | 127 (5.00) | 165.1 (6.50) |
| N | 4 | | | | | | | | | | | | | | | | | | | |
| G | 19 (0.75) | 19 (0.75) | 23 (0.91) | 15.7 (0.62) | 22.4 (0.88) | 22.4 (0.88) | 28.4 (1.12) | 18 (0.71) | 22.4 (0.88) | 28.4 (1.12) | 19 (0.75) | 19 (0.75) | 19 (0.75) | 15.7 (0.62) | 19 (0.75) | 19 (0.75) | 25.4 (1.00) | 18 (0.71) | 19 (0.75) | 25.4 (1.00) |
| WEIGHT kg (lb) | 8.3 (18.3) | 8.5 (18.7) | 12 (26.2) | 8.2 (18.1) | 9.4 (20.7) | 11.4 (25.1) | 16.3 (36.0) | 8.9 (19.6) | 11.8 (26.0) | 16.4 (36.2) | 11.2 (24.7) | 11.7 (25.9) | 14.4 (31.7) | 11.8 (26.0) | 13.3 (29.3) | 14.9 (32.8) | 26.6 (58.6) | 11.4 (25.1) | 15.9 (35.1) | 27 (60.0) |

| TYPE | REMOTE | | | | | | | | | | | | | | | | | | | | | |
|--------------------|---------------|-------------|-------------|---------------|---------------|---------------|---------------|-----------------------|-----------------------|---------------|---------------|-------------|---------------|-------------|---------------|--------------|---------------|---------------|-----------------------|-----------------------|---------------|---------------|
| MODEL CODE | DY080E1 | | | | | | | | | | DY100E1 | | | | | | | | | | | |
| PROCESS CONNECTION | BJ1 | BJ2 | BJ4 | BA1 BS1 | BA2 BS2 | BA4 BS4 | BA5 BS5 | BD1 to BD2 FD1 to FD2 | BD3 to BD4 FD3 to FD4 | CA4 | CA5 | BJ1 | BJ2 | BJ4 | BA1 BS1 | BA2 BS2 | BA4 BS4 | BA5 BS5 | BD1 to BD2 FD1 to FD2 | BD3 to BD4 FD3 to FD4 | CA4 | CA5 |
| L | 200 (7.87) | | | | | | | | | | 220 (8.66) | | | | | | | | | | | |
| C | 71 (2.80) | | | | | | | | | | | | | | | | | | | | | |
| D | 185 (7.28) | 200 (7.87) | 210 (8.27) | 190.5 (7.50) | 209.6 (8.25) | 209.6 (8.25) | 241.3 (9.50) | 200 (7.87) | 200 (7.87) | 209.6 (8.25) | 241.3 (9.50) | 210 (8.27) | 225 (8.86) | 250 (9.84) | 228.6 (9.00) | 254 (10.00) | 273 (10.75) | 292.1 (11.50) | 220 (8.66) | 235 (9.25) | 273 (10.75) | 292.1 (11.50) |
| H | 358.5 (14.11) | 366 (14.41) | 371 (14.61) | 361.5 (14.23) | 370.8 (14.60) | 370.8 (14.60) | 386.5 (15.22) | 366 (14.41) | 366 (14.41) | 370.8 (14.60) | 386.5 (15.22) | 386 (15.20) | 393.5 (15.49) | 406 (15.98) | 395.3 (15.56) | 408 (16.06) | 417.5 (16.44) | 427 (16.81) | 391 (15.39) | 398.5 (15.69) | 417.5 (16.44) | 427 (16.81) |
| H1 | 175 (6.89) | | | | | | | | | | | | | | | | | | | | | |
| T | 18 (0.71) | 22 (0.87) | 32 (1.26) | 23.9 (0.94) | 28.4 (1.12) | 38.2 (1.51) | 44.5 (1.75) | 20 (0.79) | 24 (0.94) | 39.7 (1.56) | 46 (1.81) | 18 (0.71) | 24 (0.94) | 36 (1.42) | 23.9 (0.94) | 31.8 (1.25) | 44.5 (1.75) | 50.9 (2.00) | 20 (0.79) | 24 (0.94) | 46 (1.81) | 52.4 (2.06) |
| J | 150 (5.91) | 160 (6.30) | 170 (6.69) | 152.4 (6.00) | 169.2 (6.62) | 169.2 (6.62) | 190.5 (7.50) | 160 (6.30) | 160 (6.30) | 169.2 (6.62) | 190.5 (7.50) | 169 (6.61) | 175 (6.89) | 185 (7.28) | 185 (8.07) | 190.5 (7.50) | 200.2 (7.88) | 216 (8.50) | 180 (7.09) | 190 (7.48) | 216 (8.50) | 235 (9.25) |
| N | 8 | | | | | | | | | | | | | | | | | | | | | |
| G | 19 (0.75) | 23 (0.91) | 23 (0.91) | 19 (0.75) | 22.4 (0.88) | 22.4 (0.88) | 25.4 (1.00) | 18 (0.71) | 18 (0.71) | 22.4 (0.88) | 25.4 (1.00) | 19 (0.75) | 23 (0.91) | 25 (0.98) | 19 (0.75) | 22.4 (0.88) | 25.4 (1.00) | 31.8 (1.25) | 18 (0.71) | 22 (0.87) | 25.4 (1.00) | 31.8 (1.25) |
| WEIGHT kg (lb) | 17.5 (38.6) | 20.1 (44.3) | 25.5 (56.2) | 20.1 (44.3) | 23.9 (52.7) | 25.5 (56.2) | 35.8 (79.0) | 19.5 (43.0) | 20.1 (44.3) | 27.2 (60.1) | 36.4 (80.2) | 22.9 (50.5) | 26.9 (59.3) | 38.2 (84.2) | 27.5 (61.0) | 36 (79.4) | 50.9 (112.2) | 56 (123.4) | 23.3 (51.4) | 27.5 (61.0) | 52.9 (117.0) | 56.7 (125.0) |

(Note 1) The flow direction is reversed (right to left when facing onto indicator) in case of code/CRC.

■ Stainless Steel Housing: DY150/E1 to DY400/E1

■ Flange type

Unit : mm
(approx. inch)

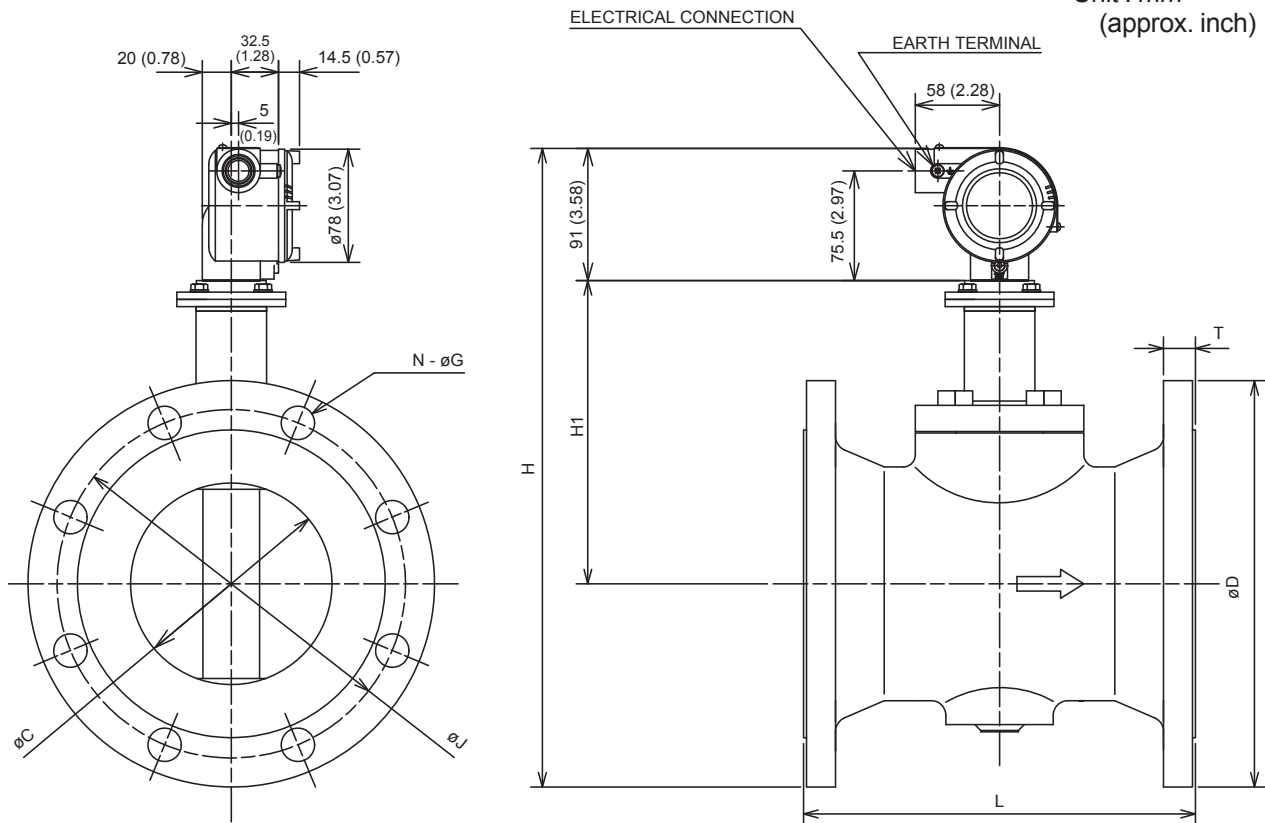

| TYPE | REMOTE | | | | | | | | | | | | | | | | | | | | | | |
|--------------------|-------------------------------|-------------|--------------|---------------|---------------|--------------|---------------|-----------------------|-----------------------|--------------|---------------|--------------|--------------|---------------|---------------|---------------|---------------|--------------|--------------|--------------|---------------|---------------|---------------|
| | DY150/E1 | | | | | | | | | DY200/E1 | | | | | | | | | | | | | |
| MODEL CODE | | | | | | | | | | | | | | | | | | | | | | | |
| PROCESS CONNECTION | BJ1 | BJ2 | BJ4 | BA1 BS1 | BA2 BS2 | BA4 BS4 | BA5 BS5 | BD1 to BD2 FD1 to FD4 | BD3 to BD4 FD3 to FD4 | CA4 | CA5 | BJ1 | BJ2 | BA1 BS1 | BA2 BS2 | BA4 BS4 | BA5 BS5 | BD1 FD1 | BD2 FD2 | BD3 FD3 | BD4 FD4 | CA4 | CA5 |
| L | 270 (10.63) | | | | | | | | | 310 (12.21) | | | | | | | | | | | | | |
| C | 138.8 (5.46) | | | | | | | | | 185.6 (7.31) | | | | | | | | | | | | | |
| D | 280 (11.02) | 305 (12.01) | 355 (13.98) | 279.4 (11.00) | 317.5 (12.50) | 356 (14.02) | 381 (15.00) | 285 (11.22) | 300 (11.81) | 356 (14.02) | 381 (15.00) | 330 (12.99) | 350 (13.78) | 342.9 (13.50) | 381 (15.00) | 419.1 (16.50) | 469.9 (18.50) | 340 (13.39) | 360 (14.17) | 375 (14.76) | 419.1 (16.50) | 469.9 (18.50) | |
| H | Shedder Bar Material: L, E, X | | | | | | | | | | | | | | | | | | | | | | |
| H | Shedder Bar Material: B | | | | | | | | | | | | | | | | | | | | | | |
| H1 | 209 (8.23) | | | | | | | | | 241 (9.49) | | | | | | | | | | | | | |
| T | 22 (0.87) | 28 (1.10) | 44 (1.73) | 25.4 (1.00) | 36.6 (1.44) | 54.4 (2.14) | 62 (2.44) | 22 (0.87) | 28 (1.10) | 55.7 (2.19) | 63.6 (2.50) | 22 (0.87) | 30 (1.18) | 28.4 (1.12) | 41.1 (1.62) | 62 (2.44) | 69.9 (2.75) | 24 (0.94) | 24 (0.94) | 30 (1.18) | 34 (1.34) | 63.6 (2.50) | 71.4 (2.81) |
| J | 240 (9.45) | 260 (10.24) | 295 (11.61) | 241.3 (9.50) | 263.7 (10.36) | 292 (11.50) | 317.5 (12.50) | 240 (9.45) | 250 (9.84) | 292 (11.50) | 317.5 (12.50) | 290 (11.42) | 305 (12.01) | 298.5 (11.74) | 330.2 (13.00) | 349.3 (13.75) | 393.7 (15.50) | 295 (11.61) | 295 (11.61) | 310 (12.20) | 320 (12.60) | 349.3 (13.75) | 393.7 (15.50) |
| N | 8 | 12 | 12 | 8 | 12 | 12 | 12 | 8 | 8 | 12 | 12 | 12 | 12 | 8 | 12 | 12 | 12 | 8 | 12 | 12 | 12 | 12 | 12 |
| G | 23 (0.91) | 25 (0.98) | 33 (1.30) | 22.4 (0.88) | 22.4 (0.88) | 28.4 (1.12) | 31.8 (1.25) | 22 (0.87) | 26 (1.02) | 28.4 (1.12) | 31.8 (1.25) | 23 (0.91) | 25 (0.98) | 22.4 (0.88) | 25.4 (1.00) | 31.8 (1.25) | 38.1 (1.50) | 22 (0.87) | 22 (0.87) | 26 (1.02) | 30 (1.18) | 31.8 (1.25) | 38.1 (1.50) |
| WEIGHT kg (lb) | 33.5 (73.9) | 43.5 (96.0) | 76.5 (168.7) | 36.5 (80.5) | 54.5 (120.2) | 84.5 (186.3) | 106.1 (234.0) | 33.5 (73.9) | 43 (94.8) | 90.1 (198.7) | 107.1 (236.1) | 45.5 (100.3) | 52.5 (115.7) | 55.5 (122.4) | 80.5 (177.5) | 136.1 (300.0) | 182.1 (401.5) | 46.4 (102.3) | 46.4 (102.3) | 53.7 (118.4) | 56 (123.5) | 139.1 (306.7) | 183.1 (403.7) |

| TYPE | REMOTE | | | | | | | | | | | |
|--------------------|-------------------------------|---------------|---------------|---------------|---------------|---------------|---------------|---------------|---------------|---------------|---------------|---------------|
| | DY250/E1 | | | | DY300/E1 | | | | DY400/E1 | | | |
| MODEL CODE | | | | | | | | | | | | |
| PROCESS CONNECTION | BJ1 | BJ2 | BA1 BS1 | BA2 BS2 | BJ1 | BJ2 | BA1 BS1 | BA2 BS2 | BJ1 | BJ2 | BA1 BS1 | BA2 BS2 |
| L | 370 (14.57) | | | | 400 (15.75) | | | | 520 (20.47) | | | |
| C | 230.8 (9.09) | | | | 276.2 (10.87) | | | | 354.2 (13.94) | | | |
| D | 400 (15.75) | 430 (16.93) | 406.4 (16.00) | 444.5 (17.50) | 445 (17.52) | 480 (18.90) | 482.6 (19.00) | 520.7 (20.50) | 560 (22.05) | 605 (23.82) | 596.9 (23.50) | 647.7 (25.50) |
| H | Shedder Bar Material: L, E, X | | | | | | | | | | | |
| H | Shedder Bar Material: B | | | | | | | | | | | |
| H1 | 277 (10.91) | | | | 307 (12.09) | | | | 374 (14.72) | | | |
| T | 24 (0.94) | 34 (1.34) | 30.2 (1.19) | 47.8 (1.88) | 24 (0.94) | 36 (1.42) | 31.8 (1.25) | 50.8 (2.00) | 28 (1.10) | 46 (1.81) | 36.6 (1.44) | 57.2 (2.25) |
| J | 355 (13.98) | 380 (14.96) | 362 (14.25) | 387.4 (15.25) | 400 (15.75) | 430 (16.93) | 431.8 (17.00) | 450.9 (17.75) | 510 (20.08) | 540 (21.26) | 539.8 (21.25) | 571.5 (22.50) |
| N | 12 | 12 | 12 | 16 | 16 | 16 | 12 | 16 | 16 | 16 | 16 | 20 |
| G | 25 (0.98) | 27 (1.06) | 25.4 (1.00) | 28.5 (1.12) | 25 (0.98) | 27 (1.06) | 25.4 (1.00) | 31.8 (1.25) | 27 (1.06) | 33 (1.30) | 28.5 (1.12) | 35.1 (1.38) |
| WEIGHT kg (lb) | 78.1 (172.1) | 100.1 (220.7) | 90.1 (198.7) | 125.1 (275.8) | 100.1 (220.7) | 128.1 (282.4) | 140.1 (308.9) | 178.1 (392.6) | 308.1 (678.2) | 300.1 (661.6) | 300.1 (661.6) | 370.1 (816.0) |

(Note 1) The flow direction is reversed (right to left when facing onto indicator) in case of code/CRC.
 (Note 2) In case of code /HX2, add 5.1kg (11.2lb).

■ Stainless Steel Housing Reduced Bore Type (/R1/E1): DY025/R1/E1 to DY150/R1/E1

■ Flange type

Unit : mm
(approx. inch)

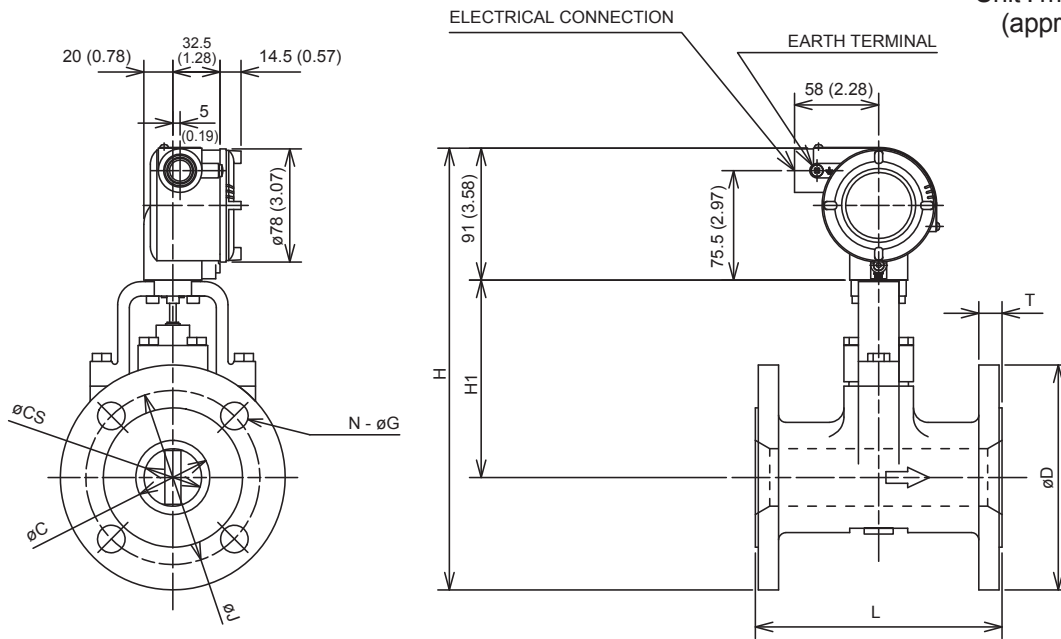

| TYPE | REMOTE | | | | | | | | | | | | | | | | | | | | | | | | | | | | | |
|--------------------|---------------|---------------|-------------|-------------|-------------|-------------|---------------|---------------|---------------|---------------|---------------|---------------|---------------|-------------|---------------|---------------|-------------|---------------|---------------|--------------|--------------|---------------|---------------|---------------|-------------|---------------|---------------|---------------|-----|-----|
| MODEL CODE | DY025/R1/E1 | | | | DY040/R1/E1 | | | | DY050/R1/E1 | | | | DY080/R1/E1 | | | | DY100/R1/E1 | | | | DY150/R1/E1 | | | | | | | | | |
| PROCESS CONNECTION | BJ1 | BJ2 | BA1 | BA2 | BS1 | BS2 | BJ1 | BJ2 | BA1 | BA2 | BS1 | BS2 | BJ1 | BJ2 | BA1 | BA2 | BS1 | BS2 | BJ1 | BJ2 | BA1 | BA2 | BS1 | BS2 | BJ1 | BJ2 | BA1 | BA2 | BS1 | BS2 |
| L | 150 (5.91) | | | | 150 (5.91) | | | | 170 (6.69) | | | | 200 (7.87) | | | | 220 (8.66) | | | | 270 (10.63) | | | | | | | | | |
| C | 25.7 (1.01) | | | | 39.7 (1.56) | | | | 51.1 (2.01) | | | | 71 (2.79) | | | | 93.8 (3.69) | | | | 138.8 (5.46) | | | | | | | | | |
| CS | 14.6 (0.57) | | | | 25.7 (1.01) | | | | 39.7 (1.56) | | | | 51.1 (2.01) | | | | 71 (2.79) | | | | 93.8 (3.69) | | | | | | | | | |
| D | 125 (4.92) | 125 (4.92) | 108 (4.25) | 124 (4.88) | 140 (5.51) | 140 (5.51) | 127 (4.94) | 155.4 (6.12) | 155 (6.10) | 155 (6.10) | 152.4 (6.00) | 165.1 (6.50) | 185 (7.28) | 200 (7.87) | 190.5 (7.50) | 209.6 (8.25) | 210 (8.27) | 225 (8.86) | 228.6 (9.00) | 254 (10.00) | 280 (11.02) | 305 (12.01) | 279.4 (11.00) | 317.5 (12.50) | 280 (11.02) | 305 (12.01) | 279.4 (11.00) | 317.5 (12.50) | | |
| H | 280.5 (11.04) | 280.5 (11.04) | 272 (10.71) | 280 (11.02) | 290 (11.42) | 290 (11.42) | 283.5 (11.16) | 297.7 (11.72) | 304.5 (11.99) | 304.5 (11.99) | 303.2 (11.94) | 309.5 (12.16) | 341.5 (13.44) | 349 (13.74) | 344.5 (13.57) | 353.8 (13.93) | 371 (14.61) | 378.5 (14.90) | 380.3 (14.97) | 393 (15.47) | 421 (16.57) | 433.5 (17.07) | 420.7 (16.56) | 439.5 (17.31) | 421 (16.57) | 433.5 (17.07) | 420.7 (16.56) | 439.5 (17.31) | | |
| H1 | 127 (5.00) | | | | 129 (5.07) | | | | 136 (5.35) | | | | 158 (6.22) | | | | 175 (6.89) | | | | 190 (7.48) | | | | | | | | | |
| T | 14 (0.55) | 16 (0.63) | 14.2 (0.56) | 17.5 (0.69) | 16 (0.63) | 18 (0.71) | 17.5 (0.69) | 20.6 (0.81) | 16 (0.63) | 18 (0.71) | 19.1 (0.75) | 22.4 (0.88) | 18 (0.71) | 22 (0.87) | 23.9 (0.94) | 28.4 (1.11) | 18 (0.71) | 24 (0.94) | 23.9 (0.94) | 31.8 (1.25) | 22 (0.87) | 28 (1.10) | 25.4 (1.00) | 36.6 (1.44) | 22 (0.87) | 28 (1.10) | 25.4 (1.00) | 36.6 (1.44) | | |
| J | 90 (3.54) | 90 (3.54) | 79.2 (3.12) | 89 (3.50) | 105 (4.13) | 105 (4.13) | 98.6 (3.88) | 114.3 (4.50) | 120 (4.72) | 120 (4.72) | 120.7 (4.75) | 127 (5.00) | 150 (5.91) | 160 (6.30) | 152.4 (6.00) | 168.2 (6.62) | 175 (6.89) | 185 (7.28) | 190.5 (7.50) | 200.2 (7.88) | 240 (9.45) | 260 (10.24) | 241.3 (9.50) | 269.7 (10.62) | 240 (9.45) | 260 (10.24) | 241.3 (9.50) | 269.7 (10.62) | | |
| N | 4 | | | | 4 | | | | 4 | | | | 8 | | | | 8 | | | | 8 | | | | | | | | | |
| G | 19 (0.75) | 19 (0.75) | 15.7 (0.62) | 19 (0.75) | 19 (0.75) | 19 (0.75) | 15.7 (0.62) | 22.4 (0.88) | 19 (0.75) | 19 (0.75) | 19 (0.75) | 19 (0.75) | 19 (0.75) | 19 (0.75) | 23 (0.91) | 19 (0.75) | 22.4 (0.88) | 19 (0.75) | 23 (0.91) | 19 (0.75) | 22.4 (0.88) | 23 (0.91) | 25 (0.98) | 22.4 (0.88) | 23 (0.91) | 25 (0.98) | 22.4 (0.88) | 23 (0.91) | | |
| WEIGHT kg (lb) | 6.2 (13.7) | 6.6 (14.6) | 5.6 (12.3) | 7.1 (15.7) | 9.7 (21.4) | 10.2 (22.5) | 9.5 (21.0) | 12.7 (30.1) | 10.6 (23.4) | 11.2 (24.7) | 11.5 (25.4) | 13.7 (30.2) | 18.7 (41.2) | 21.8 (48.1) | 22 (49.0) | 27 (60.0) | 25.1 (55.3) | 30.1 (66.4) | 30.7 (67.7) | 41.4 (91.3) | 46 (101.4) | 56.4 (124.3) | 49.5 (109.1) | 71.8 (158.3) | 46 (101.4) | 56.4 (124.3) | 49.5 (109.1) | 71.8 (158.3) | | |

(Note 1) The flow direction is reversed (right to left when facing onto indicator) in case of code/CRC.

- Stainless Steel Housing Reduced Bore Type (/R1/E1): DY025/R1/E1 to DY150/R1/E1
- High pressure flange type

Unit : mm
(approx. inch)

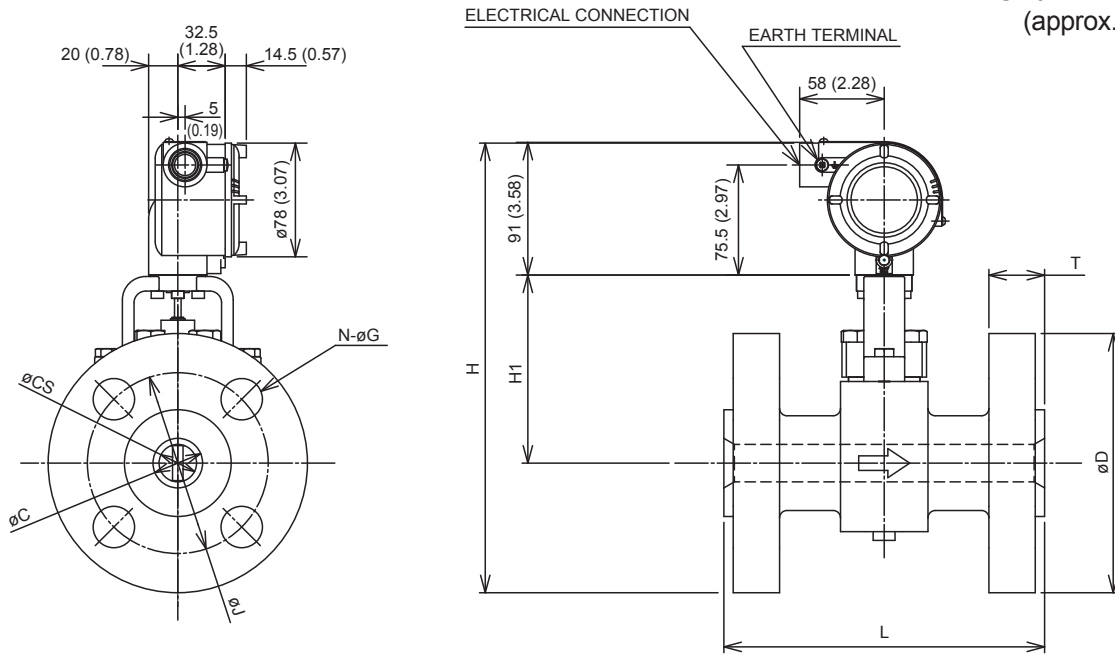

| TYPE | INTEGRAL/REMOTE | | | | | | | | | | | |
|----------------|-----------------|-------------|---------------|-------------|--------------|-------------|---------------|--------------|---------------|---------------|---------------|---------------|
| | DY025/E1/R1 | | DY040/E1/R1 | | DY050/E1/R1 | | DY080/E1/R1 | | DY100/E1/R1 | | DY150/E1/R1 | |
| MODEL CODE | BA6 | CA6 | BA6 | CA6 | BA6 | CA6 | BA6 | CA6 | BA6 | CA6 | BA6 | CA6 |
| L | 220 (8.66) | | 220 (8.66) | | 230 (9.06) | | 280 (11.02) | | 300 (11.81) | | 400 (15.75) | |
| C | 20.7 (0.81) | | 34 (1.34) | | 42.8 (1.69) | | 66.6 (2.62) | | 87.3 (3.44) | | 131.8 (5.19) | |
| CS | 14.6 (0.57) | | 25.7 (1.01) | | 39.7 (1.56) | | 51.1 (2.01) | | 71 (2.80) | | 93.8 (3.69) | |
| D | 149.4 (5.88) | | 177.8 (7.00) | | 215.9 (8.50) | | 266.7 (10.50) | | 311.2 (12.25) | | 393.7 (15.50) | |
| H | 292.7 (11.52) | | 308.9 (12.16) | | 335 (13.19) | | 382.4 (15.06) | | 421.6 (16.60) | | 477.9 (18.81) | |
| H1 | 127 (5.00) | | 129 (5.08) | | 136 (5.35) | | 158 (6.22) | | 175 (6.89) | | 190 (7.48) | |
| T | 34.9 (1.37) | | 38.2 (1.50) | | 44.5 (1.75) | 46.1 (1.81) | 54.2 (2.13) | 55.8 (2.20) | 60.3 (2.37) | 61.8 (2.43) | 89 (3.50) | 92.1 (3.63) |
| J | 101.6 (4.00) | | 124 (4.88) | | 165.1 (6.50) | | 203.2 (8.00) | | 241.3 (9.50) | | 317.5 (12.50) | |
| N | 4 | | 4 | | 8 | | 8 | | 8 | | 12 | |
| G | 25.4 (1.00) | | 28.4 (1.12) | | 25.4 (1.00) | | 31.8 (1.25) | | 35.1 (1.38) | | 38.1 (1.50) | |
| WEIGHT kg (lb) | 14.5 (32.0) | 15.8 (34.8) | 23 (50.7) | 24.8 (54.7) | 37.3 (82.2) | 40.3 (88.8) | 68.6 (151.2) | 72.8 (160.5) | 103.6 (228.4) | 108.6 (239.4) | 229.4 (505.7) | 235.8 (519.8) |

(Note 1) The flow direction is reversed (right to left when facing onto indicator) in case of code/CRC.

■ Stainless Steel Housing Reduced Bore Type (/R1/E1): DY200/R1/E1

■ Flange type

Unit : mm
(approx. inch)

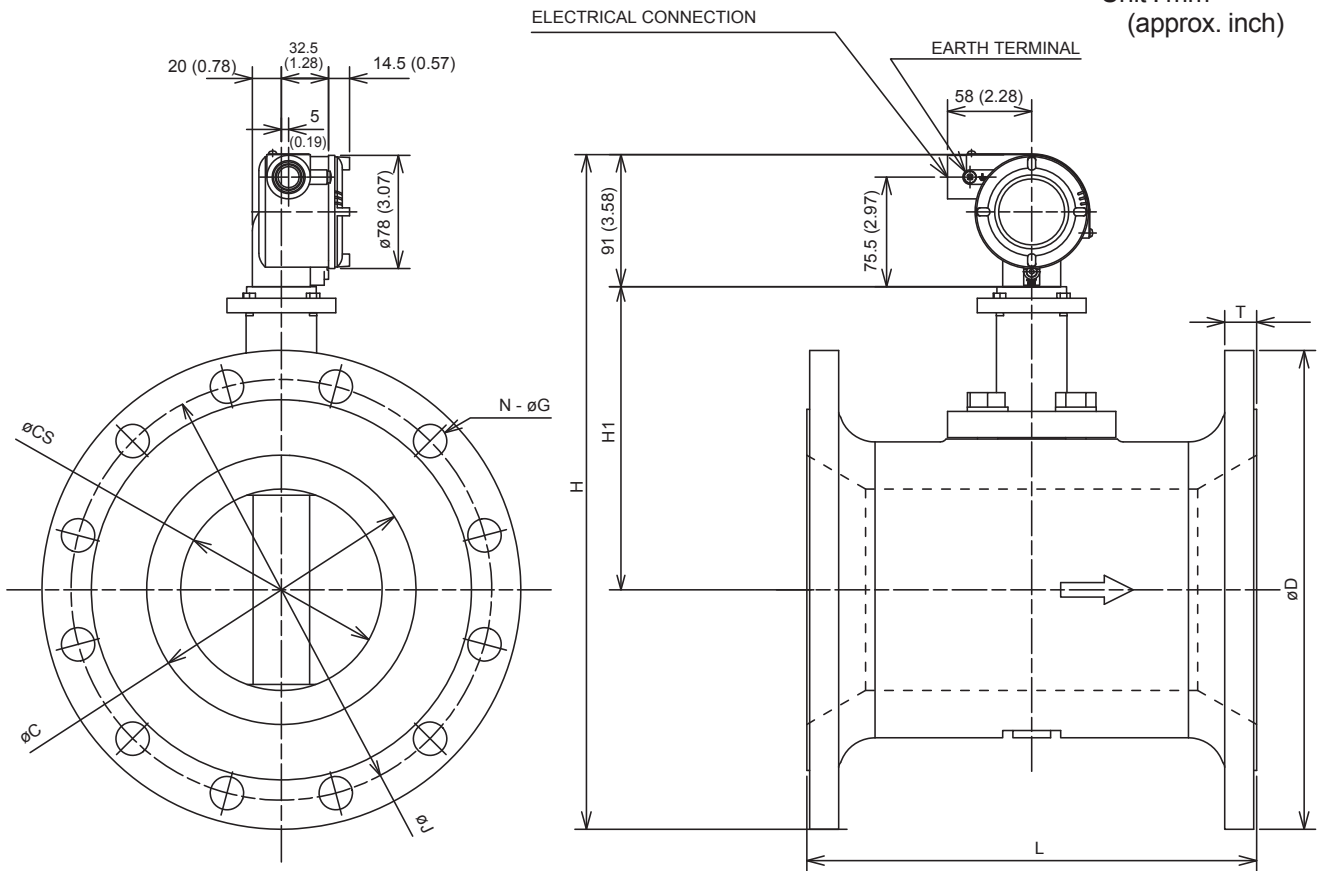

| TYPE | | REMOTE | | | |
|--------------------|-------------------------------|--------------|--------------|---------------|---------------|
| MODEL CODE | | DY200/R1/E1 | | | |
| PROCESS CONNECTION | | BJ1 | BJ2 | BA1 BS1 | BA2 BS2 |
| L | | 310 (12.20) | | | |
| C | | 185.6 (7.31) | | | |
| CS | | 138.8 (5.46) | | | |
| D | | 330 (12.99) | 350 (13.78) | 342.9 (13.50) | 381 (15.00) |
| H | Shedder Bar Material: L, E, X | 465 (18.31) | 475 (18.70) | 471.5 (18.56) | 490.5 (19.31) |
| | Shedder Bar Material: B | 472 (18.58) | 482 (18.98) | 478.5 (18.84) | 497.5 (19.59) |
| H1 | Shedder Bar Material: L, E, X | 209 (8.23) | | | |
| | Shedder Bar Material: B | 216 (8.50) | | | |
| T | | 22 (0.87) | 30 (1.18) | 28.4 (1.12) | 41.1 (1.62) |
| J | | 290 (11.42) | 305 (12.01) | 298.5 (11.75) | 330.2 (13.00) |
| N | | 12 | 12 | 8 | 12 |
| G | | 23 (0.91) | 25 (0.98) | 22.4 (0.88) | 25.4 (1.00) |
| WEIGHT kg (lb) | | 58.8 (129.6) | 74.2 (163.6) | 70.8 (156.1) | 103 (227.1) |

(Note 1) The flow direction is reversed (right to left when facing onto indicator) in case of code/CRC.

■ Stainless Steel Housing Reduced Bore Type (R2/E1): DY040/R1/E1 to DY200/R2/E1

■ Flange type

Unit : mm
(approx. inch)

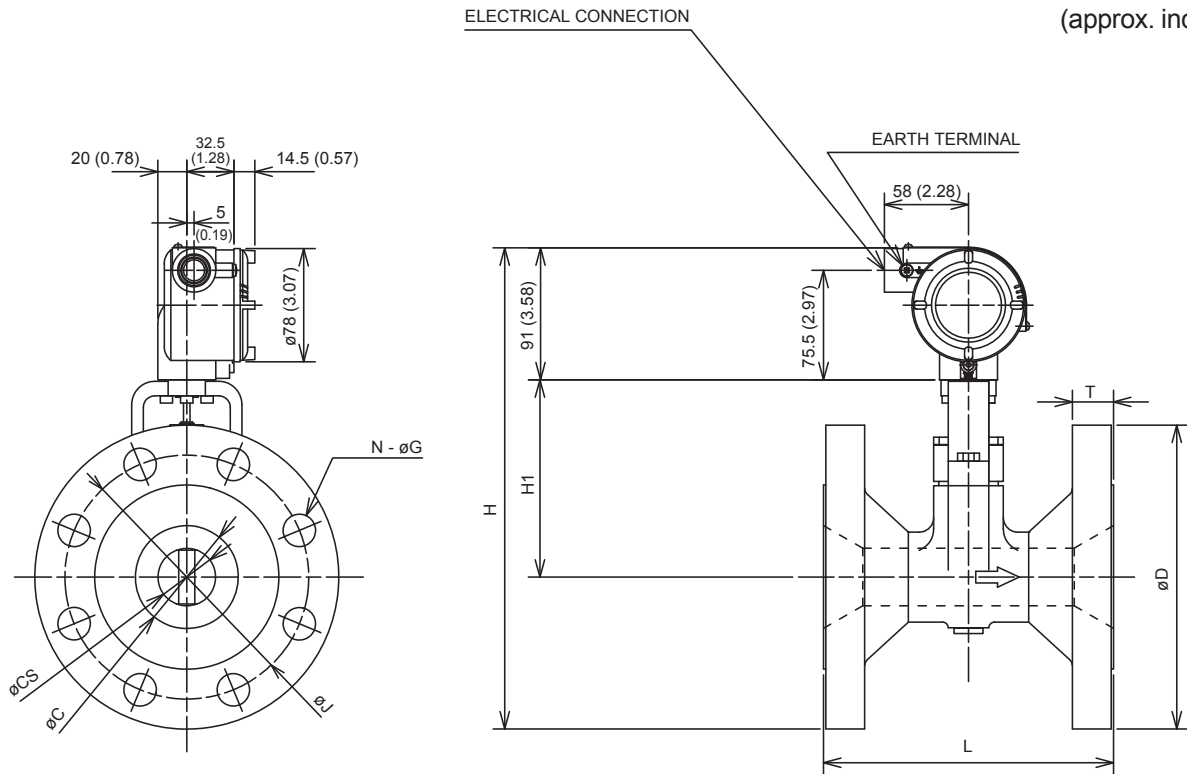

| TYPE | REMOTE | | | | | | | | | | | | | | | | | | | | | | | | | | | | | | | | | | | |
|----------------|-------------|-------------|---------------|---------------|---------------|---------------|---------------|---------------|---------------|-------------|---------------|---------------|-------------|---------------|---------------|--------------|--------------|---------------|---------------|---------------|--------------|-------------|---------------|---------------|-----------|-----------|-------------|-------------|-----------|-----------|-------------|-------------|-----|-----|-----|-----|
| | DY040/R2/E1 | | | | DY050/R2/E1 | | | | DY080/R2/E1 | | | | DY100/R2/E1 | | | | DY150/R2/E1 | | | | DY200/R2/E1 | | | | | | | | | | | | | | | |
| MODEL CODE | BJ1 | BJ2 | BA1 | BA2 | BS1 | BS2 | BJ1 | BJ2 | BA1 | BA2 | BS1 | BS2 | BJ1 | BJ2 | BA1 | BA2 | BS1 | BS2 | BJ1 | BJ2 | BA1 | BA2 | BS1 | BS2 | BJ1 | BJ2 | BA1 | BA2 | BS1 | BS2 | BJ1 | BJ2 | BA1 | BA2 | BS1 | BS2 |
| L | 150 (5.91) | | | | 170 (6.69) | | | | 200 (7.87) | | | | 220 (8.66) | | | | 270 (10.63) | | | | 310 (12.20) | | | | | | | | | | | | | | | |
| C | 39.7 (1.56) | | | | 51.1 (2.01) | | | | 71 (2.79) | | | | 93.8 (3.69) | | | | 138.8 (5.46) | | | | 185.6 (7.30) | | | | | | | | | | | | | | | |
| CS | 14.6 (0.57) | | | | 25.7 (1.01) | | | | 39.7 (1.56) | | | | 51.1 (2.01) | | | | 71 (2.79) | | | | 93.8 (3.69) | | | | | | | | | | | | | | | |
| D | 140 (5.51) | 140 (5.51) | 127 (4.94) | 155.4 (6.12) | 155 (6.10) | 155 (6.10) | 152.4 (6.00) | 165.1 (6.50) | 185 (7.28) | 200 (7.87) | 190.5 (7.50) | 209.6 (8.25) | 210 (8.27) | 225 (8.86) | 228.6 (9.00) | 254 (10.00) | 280 (11.02) | 305 (12.01) | 279.4 (11.00) | 317.5 (12.50) | 330 (12.99) | 350 (13.78) | 342.9 (13.50) | 381 (15.00) | | | | | | | | | | | | |
| H | 288 (11.34) | 288 (11.34) | 281.5 (11.08) | 295.7 (11.64) | 297.5 (11.71) | 297.5 (11.71) | 296.2 (11.66) | 302.5 (11.91) | 319.5 (12.58) | 327 (12.87) | 322.5 (12.70) | 331.8 (13.06) | 354 (13.94) | 361.5 (14.23) | 363.3 (14.30) | 376 (14.80) | 406 (15.98) | 418.5 (16.48) | 405.7 (15.97) | 424.5 (16.71) | 446 (17.56) | 456 (17.95) | 452.5 (17.82) | 471.5 (18.56) | | | | | | | | | | | | |
| H1 | 127 (5.00) | | | | 129 (5.07) | | | | 136 (5.35) | | | | 158 (6.22) | | | | 175 (6.89) | | | | 190 (7.48) | | | | | | | | | | | | | | | |
| T | 16 (0.63) | 18 (0.71) | 17.5 (0.69) | 20.6 (0.81) | 16 (0.63) | 18 (0.71) | 19.1 (0.75) | 22.4 (0.88) | 18 (0.71) | 22 (0.87) | 23.9 (0.94) | 28.4 (1.11) | 18 (0.71) | 24 (0.94) | 23.9 (0.94) | 31.8 (1.25) | 22 (0.87) | 28 (1.10) | 25.4 (1.00) | 36.6 (1.44) | 22 (0.87) | 30 (1.18) | 28.4 (1.11) | 41.1 (1.62) | | | | | | | | | | | | |
| J | 105 (4.13) | 105 (4.13) | 98.6 (3.88) | 114.3 (4.50) | 120 (4.72) | 120 (4.72) | 120.7 (4.75) | 127 (5.00) | 150 (5.91) | 160 (6.30) | 152.4 (6.00) | 168.2 (6.62) | 175 (6.89) | 185 (7.28) | 190.5 (7.50) | 200.2 (7.88) | 240 (9.45) | 260 (10.24) | 241.3 (9.50) | 269.7 (10.62) | 290 (11.42) | 305 (12.01) | 298.5 (11.75) | 330.2 (13.00) | | | | | | | | | | | | |
| N | 4 | | | | 8 | | | | 8 | | | | 8 | | | | 8 | | | | 8 | | | | | | | | | | | | | | | |
| G | 19 (0.75) | 19 (0.75) | 15.7 (0.62) | 22.4 (0.88) | 19 (0.75) | | | | 19 (0.75) | 23 (0.91) | 19 (0.75) | 22.4 (0.88) | 19 (0.75) | 23 (0.91) | 19 (0.75) | 22.4 (0.88) | 23 (0.91) | 25 (0.98) | 22.4 (0.88) | 22.4 (0.88) | 23 (0.91) | 25 (0.98) | 22.4 (0.88) | 25.4 (1.00) | 23 (0.91) | 25 (0.98) | 22.4 (0.88) | 22.4 (0.88) | 23 (0.91) | 25 (0.98) | 22.4 (0.88) | 25.4 (1.00) | | | | |
| WEIGHT kg (lb) | 7.8 (17.2) | 8 (17.6) | 7.7 (17.1) | 8.9 (20.0) | 10.1 (22.3) | 10.6 (23.4) | 10.7 (23.6) | 12.2 (26.9) | 13.7 (30.2) | 16.3 (36.0) | 16.3 (36.0) | 20.1 (44.3) | 21 (46.3) | 25 (55.1) | 25.6 (56.4) | 34.1 (75.2) | 40.4 (89.1) | 50.4 (111.1) | 43.4 (95.7) | 61.4 (135.4) | 62 (136.7) | 69 (152.1) | 72 (158.7) | 97 (213.8) | | | | | | | | | | | | |

(Note 1) The flow direction is reversed (right to left when facing onto indicator) in case of code/CRC.

■ Remote Type Converter (DYA)

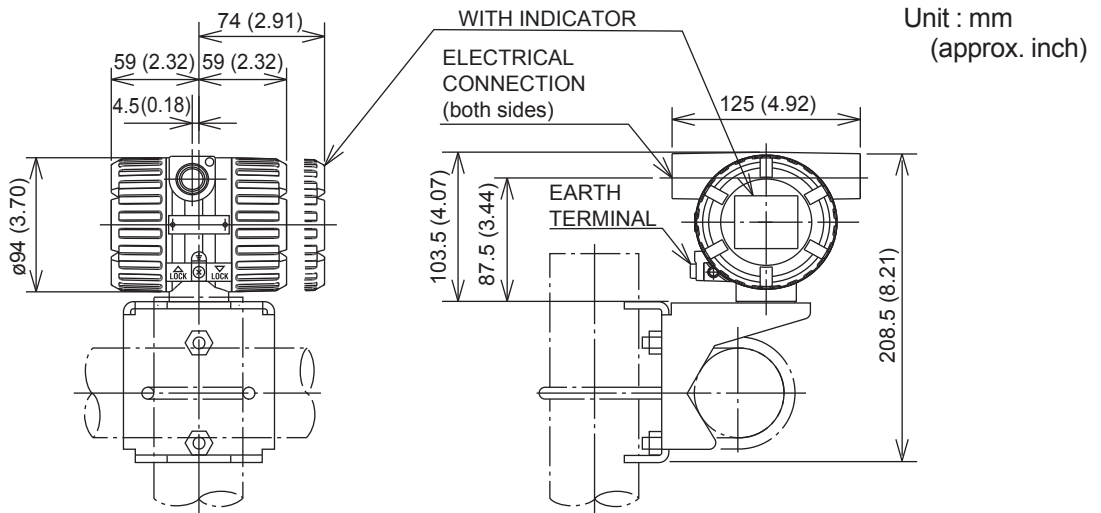

Weight: 1.9 kg (4.2lb), 4.1 kg (9.0lb) for /E1.
 Note: For flowmeters with indicator, add 0.2 kg (0.4lb), 0.3 kg (0.7lb) for /E1.

■ Signal Cable for Remote Type (DYC)

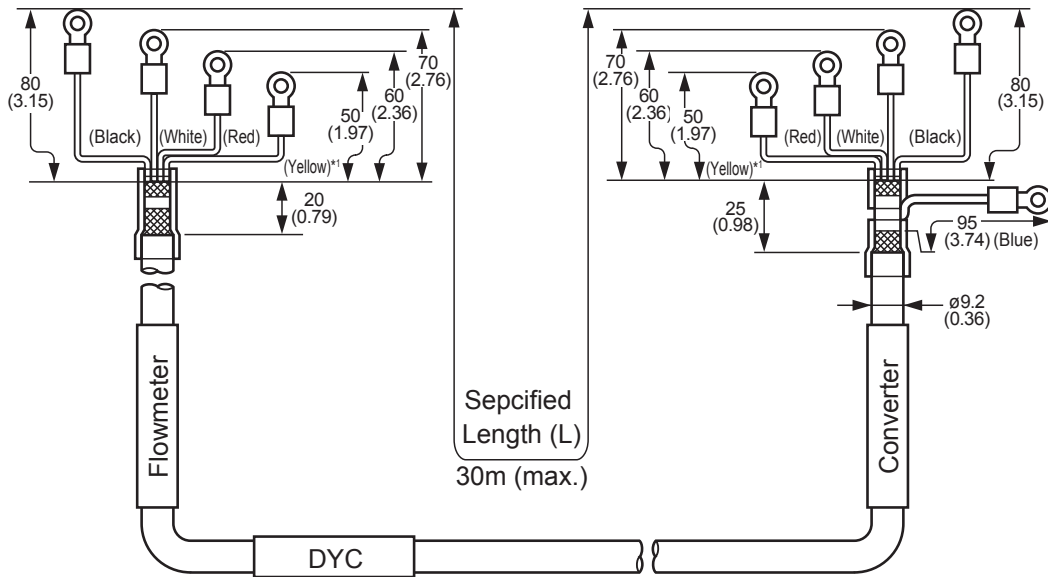

Cable Color and Terminal

| Color | Terminal | |
|-------------|------------|-----------|
| | Flow meter | Converter |
| Yellow (*1) | T | T |
| Red | A | A |
| White | B | B |
| Black | ± | C |
| Blue | | ± |

(*1) Only for /MV

■ Flameproof Packing Adapter (/G11, /G12)

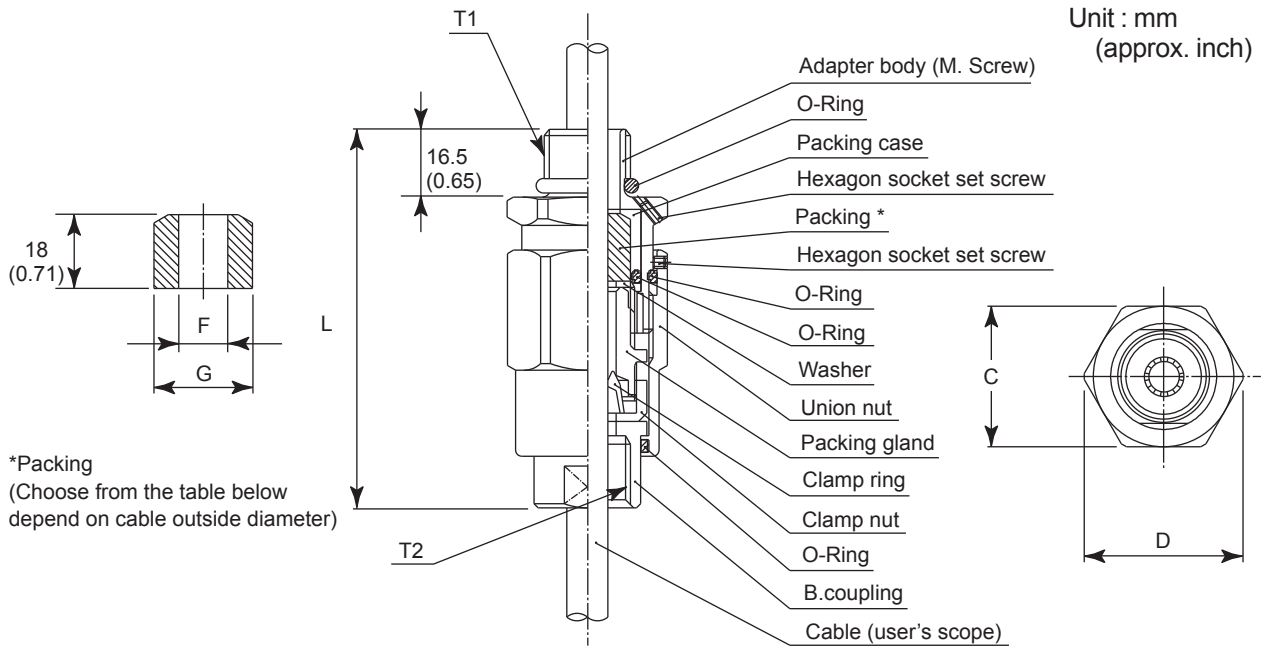

| Size | | | | | Cable outer diameter | Packing dimensions | | Identification mark | Weight kg (lb) |
|-------|-------|--------------|--------------|----------------|------------------------------------|--------------------|------------------|---------------------|----------------|
| T1 | T2 | C | D | L | | F | G | | |
| G 1/2 | G 1/2 | 35 (1.38) | 39 (1.54) | 94.5 (3.72) | ø8.0 to ø10.0 (ø0.31 to ø0.39) | ø10.0 (ø0.39) | ø20.0 (ø0.79) | 16 8-10 | 0.26 (0.57) |
| | | | | | ø10.0 to ø12.0 (ø0.39 to ø0.47) | ø12.0 (ø0.47) | | 16 10-12 | |

14. EXPLOSION PROTECTED TYPE INSTRUMENT

In this chapter, further requirements and differences for explosion protected type instrument are described except TIS Flame proof. For explosion protected type, the description in this chapter is prior to other description in this User's Manual.



WARNING

Only trained persons use this instrument in industrial locations.



CAUTION

Process temperature and ambient temperature on this section are specifications for explosion protected type. Read section 13.1 "Standard Specifications" before operating.

14.1 ATEX



WARNING

- Only trained persons use this instrument in industrial locations.
- A modification of the equipment would no longer comply with the construction described in the certificate documentation.

(1) Technical Data

• Flameproof

Applicable Standard: EN 60079-0:2012+A11:2013
EN 60079-1:2014

Certificate: DEKRA 11ATEX0212X

Type of Protection:

Ex db IIC T6...T1 Gb (Integral Type and Remote Type Detector)

Ex db IIC T6 Gb (Remote Type Converter)

Group: II, Category: 2 G

Specification of Protection:

Temperature Class: (Integral Type and Remote Type Detector)

| Temperature Class | Process Temperature |
|-------------------|---------------------|
| T6 | -40°C to +80°C |
| T5 | -40°C to +100°C |
| T4 | -40°C to +135°C |
| T3 | -40°C to +200°C |
| T2 | -40°C to +300°C |
| T1 | -40°C to +450°C |

*1 Note: Use /HT version above +250°C

Temperature Class: T6 (Remote Type Converter)

Ambient Temperature:

-30 to +60°C (With Indicator)

-40 to +60°C (Without Indicator)

Power Supply: 10.5 to 42Vdc max.

Output Signal: Current Output; 4 to 20mA

Pulse Output; On=2Vdc, 200mA

Off=42Vdc, 4mA

Specific conditions of use

- Electrostatic charges on the non-metallic parts (excluding glass parts) or coated parts of the equipment shall be avoided.
- The flameproof joints differ from the standard values in IEC 60079-1. Only personnel authorized by the manufacturer of the equipment can repair the flameproof joints.
- The property class of the fasteners used to fasten the sensor assembly part the transmitter enclosure is at least A2-50.

• Intrinsically Safe

Applicable Standard: EN 60079-0:2012+A11:2013
EN 60079-11:2012

Certificate: DEKRA 13ATEX0192 X

Type of protection:

Ex ia IIC T4...T1 Ga (Integral Type)

Ex ia IIC T6...T1 Ga (Remote Type Detector)

Ex ia IIC T4 Ga (Remote Type Converter)

Group: II, Category: 1G

Ambient Temperature:

-50 to +60°C (Integral Type)

-50 to +80 [+79]°C (Remote Type Detector)

(Option /LT below -29°C, [] for Option /MV at T6)

-50 to +80°C (Remote Type Converter)

Temperature Class:

(Integral Type)

| Temperature Class | Process Temperature |
|-------------------|---------------------|
| T4 | -50°C to +135°C |
| T3 | -50°C to +199°C |
| T2 | -50°C to +250°C |
| T1 | -50°C to +250°C |

(Remote Type Detector)

| Temperature Class | Process Temperature * |
|-------------------|-------------------------|
| T6 | -196°C to +84/[+79]°C |
| T5 | -196°C to +100°C |
| T4 | -196°C to +135°C |
| T3 | -196°C to +199°C |
| T2 | -196°C to +299/[+289]°C |
| T1 | -196°C to +449/[+439]°C |

*: Use /HT option above +250°C, use /LT option below -29°C, [] for /MV option.

Electrical data:

Supply and Output Circuit

(SUPPLY + and -, PULSE + and -);

Maximum Input Voltage U_i : 30Vdc

Maximum Input Current i_i : 300mA

(Read Contact rating for pulse output.)

Maximum Input Power P_i : 0.9 W

Internal Capacitance C_i : 14nF

Internal Inductance L_i : 0mH

Electrical Connection: ANSI 1/2 NPT female,

ISO M20 X 1.5 female

Specific conditions of use

- Electrostatic charges on the non-metallic parts (excluding glass parts) or coated parts of the equipment shall be avoided.
- When the enclosure of the flow meter or the converter are made of aluminum, if it is mounted in an area where the use of EPL Ga equipment is required, it must be installed such that, even in the event of rare incidents, ignition sources due to impact and friction sparks are excluded.
- The dielectric strength of at least 500 V a.c. r.m.s. between the intrinsically safe circuits and the enclosure of the flow meter or the converter is limited only by the overvoltage protection.

(2) Installation



WARNING

- Take care the following warning marking. "POTENTIAL ELECTROSTATIC CHARGING HAZARD"
- Electrostatic charge may cause an explosion hazard. Avoid any actions that cause the generation of electrostatic charge, such as rubbing with a dry cloth on coating face of the product.
- All wiring shall comply with IEC 60079-14, and local electric codes and requirements.
- In cases where the process temperature exceeds 200 °C, use external heat resistant cable and cable gland with a maximum allowable temperature of 90 °C or above.
- In case of Flameproof, Cable glands and/or adapters with a suitable temperature rating shall be of Ex db certified by ATEX.
- Cable glands and adapters shall be installed so as to maintain the specified degree of protection (IP Code) of the flowmeter.
- In order to prevent the earthing conductor from loosening, the conductor must be secured to the terminal, tightening the screw with appropriate torque. Care must be taken not to twist the conductor.

The grounding terminals are located on the inside and outside of the terminal area.

Connect the cable to grounding terminal in accordance with wiring procedure (1) or (2).

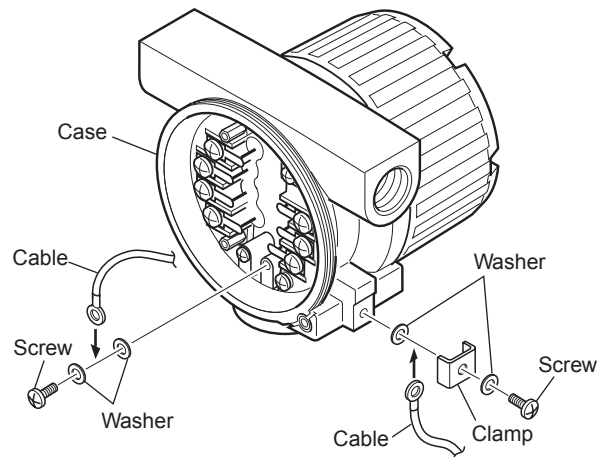

(1) Internal grounding terminal (2) External grounding terminal F1401.ai

Figure 14.1 Wiring Procedure for Grounding Terminals

(3) Operation



WARNING

- Take care the following warning marking. "POTENTIAL ELECTROSTATIC CHARGING HAZARD"
- Electrostatic charge may cause an explosion hazard. Avoid any actions that cause the generation of electrostatic charge, such as rubbing with a dry cloth on coating face of the product.
- Take care not to generate mechanical spark when access to the equipment and the peripheral devices in hazardous locations.
- In case of Flameproof, take care the following warning marking when opening the cover. "AFTER DE-ENERGIZING, DELAY 3 MINUTES BEFORE OPENING"

(4) Maintenance and Repair



WARNING

When maintenance and repair are performed, confirm the following conditions and the then perform works.
 Confirm the power supply is cut off and the voltage of power supply terminal is not supplied. Only personnel authorized by Yokogawa Electric Corporation can repair the equipment in accordance with the relevant standards: EN 60079-19 (Equipment repair, overhaul and reclamation) and EN 60079-17 (Electrical installation inspection and maintenance).

(5) Installation Diagram of Intrinsically safe (and Note)

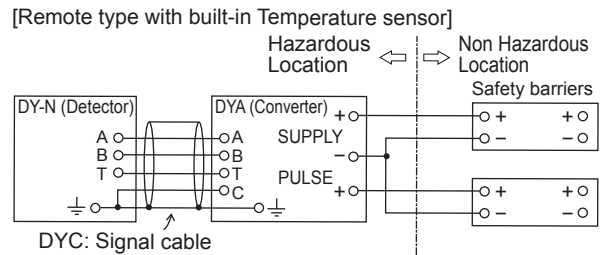
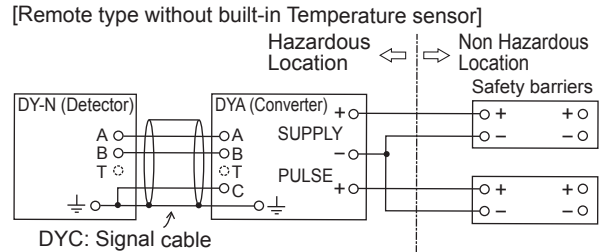
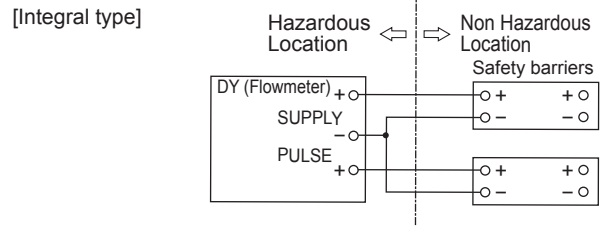

Electrical data:
 Signal/Supply Circuit (Terminals SUPPLY + and -):
 $U_i = 30\text{ V}$, $I_i = 300\text{ mA}$, $P_i = 0.9\text{ W}$ (linear source),
 $C_i = 14\text{ nF}$, $L_i = 0\text{ mH}$
 Pulse Circuit (Terminals PULSE + and -):
 $U_i = 30\text{ V}$, $I_i = 300\text{ mA}^*$, $P_i = 0.9\text{ W}$ (linear source),
 $C_i = 14\text{ nF}$, $L_i = 0\text{ mH}$
 *: Refer to "Contact rating" for the maximum current value of Pulse Circuit

Note:
 - It shall be assured that the voltage difference between the output circuits of the associated apparatus (safety barriers) is not more than 30V.
 - Cables for the connection for Signal/Supply Circuit and Pulse Circuit shall be of Type A or B in accordance with EN 60079-14, otherwise the sum of I_o of the associated apparatus (safety barriers) shall be not more than 300 mA.

F1402.ai

(6) Electrical Connection

The type of electrical connection is stamped near the electrical connection port according to the following codes.

| Screw size | Marking |
|----------------------|---------|
| ISO M20 X 1.5 female | M |
| ANSI 1/2NPT female | N |

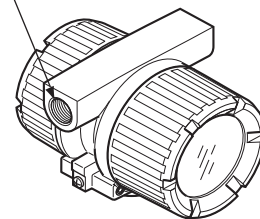

F1403.ai

(7) Name Plate

Example for name plates in case of “Flameproof, Integral type”

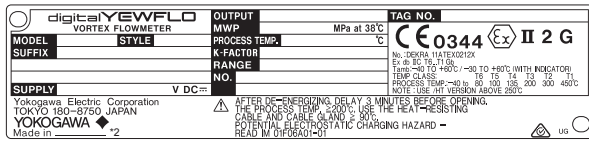

- MODEL: Specified model code
- SUFFIX: Specified suffix code
- STYLE: Style code
- SUPPLY: Supply voltage
- OUTPUT: Output signal
- MWP: Maximum working pressure
- PROCESS TEMP.: Process temperature
- K-FACTOR: Device-specific factor
- RANGE: Specified range
- NO.: Upper column: Manufacturing serial number *3
Lower column: The year and month of production
- TAG NO.: Specified TAG No.
- Tokyo 180-8750 JAPAN: address of manufacturer. *4
- 0344: The identification number of the notified body
- Ex II 2 G: Specific ATEX Marking *1
- DEKRA 11ATEX0212X: Certificate number *1
- Ex db IIC T6...T1 Gb: Type of Protection *1

*1) Example for “Flameproof, Integral type”
 *2) The product - producing country
 *3) The first number in the second block of “NO.” column is the last one number of the production year. For example, the year of production of the product engraved as follows is year 2018.
 NO. S5K965926 835 7
 ↑
 Produced in 2018

*4) “180-8750” is a zip code which represents the following address: 2-9-32 Nakacho, Musashino-shi, Tokyo Japan

14.2 FM

(1) Technical Data

• Explosion Proof

Applicable Standard: CLASS 3600 2011,
 CLASS 3611 2004,
 CLASS 3615 2006,
 CLASS 3810 1989,
 Including Supplement 1 1995,
 NEMA 250 1991

Type of Protection:

Explosionproof for Class I, Division 1,
 Groups A, B, C and D;
 Dust-ignition proof for Class II/III, Division 1,
 Groups E, F, and G.

“SEAL ALL CONDUITS 18 INCHES.”
 “WHEN INSTALLED IN DIV.2, SEALS NOT
 REQUIRED”

Enclosure Rating: Type 4X

Temperature Code: T6

Ambient Temperature:

-40 to +60°C (Integral Type and Remote Type
 Detector)
 -40 to +60°C (Remote Type Converter)

Power Supply: 42Vdc max. (Integral Type and
 Remote Type Converter)

Output Signal (Integral Type):

Current Output; 4 to 20mAdc
 Pulse Output; On=2Vdc, 200mA
 Off=42Vdc, 4mA

Output Signal (Remote Type Detector):

Output Signal to Converter; 30Vp-p,
 100µAp-p

Input/Output Signal (Remote Type Converter):

Current Output; 4 to 20mAdc
 Pulse Output; On=2Vdc, 200mA
 Off=42Vdc, 4mA

Input Signal from Flowmeter;
 30Vp-p, 100µAp-p

Electrical connection: ANSI 1/2 NPT female

• Intrinsically Safe

Applicable Standard: CLASS 3600 1998,
CLASS 3610 2010,
CLASS 3611 2004,
CLASS 3810 2005,
NEMA 250 1991,
ANSI/ISA-60079-0: 2009,
ANSI/ISA-60079-11: 2009

Type of Protection:

Intrinsically safe for Class I, II, III, Div.1, Groups A, B, C, D, E, F and G, T4 and Class I, Zone 0, AEx ia IIC T4 Nonincendive for Class I, II, Div. 2, Groups A, B, C, D, F and G, Class III, Div.1, T4, and Class I, Zone 2, Group IIC, T4

Ambient Temperature:

–40 to +60°C (Integral Type and Remote Type Converter)

–40 to +80°C (Remote Type Detector)

Indoors and Outdoors: Type 4X

Electrical Parameters: $V_{max}=30V_{dc}$,
 $I_{max}=165mA_{dc}$,
 $P_i=0.9W$, $C_i=12nF$,
 $L_i=0.15mH$

Electrical connection: ANSI 1/2 NPT female

(2) Wiring**• Explosion proof****WARNING**

- All wiring shall comply with National Electrical Code ANSI/NFPA 70 and Local Electrical Code.
- “SEAL ALL CONDUITS 18 INCHES”
“WHEN INSTALLED DIV.2, SEALS NOT REQUIRED”.

• Intrinsically Safe**NOTE**

For using a hand-held terminal in the hazardous area, read the Control Drawing or Instruction Manual of handheld terminal.

(3) Operation**• Explosion proof****WARNING**

- In case of Explosion proof, note a warning label worded as follows.
Warning: OPEN CIRCUIT BEFORE REMOVING COVER.
INSTALL IN ACCORDANCE WITH THE INSTRUCTION MANUAL (IM) 01F06A00-01EN.
- Take care not to generate mechanical spark when access to the instrument and peripheral devices in hazardous locations.

(4) Maintenance and Repair**WARNING**

The instrument modification or part replacements by other than authorized personnel of Yokogawa Electric Corporation is prohibited and will void the approval of FM Approvals.

(5) Control Drawing

Model: DY Series

Date: April 16, 2001

12. Drawings

12.1 Installation Diagram

Intrinsically safe

Hazardous Location ← → Non Hazardous Location

Class I, II, III, Division 1,
Groups A,B,C,D,E,F and G,
and Class I, Zone 0, Group IIC

[Integral type]

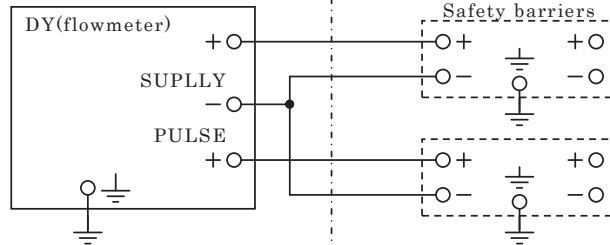

[Remote type]

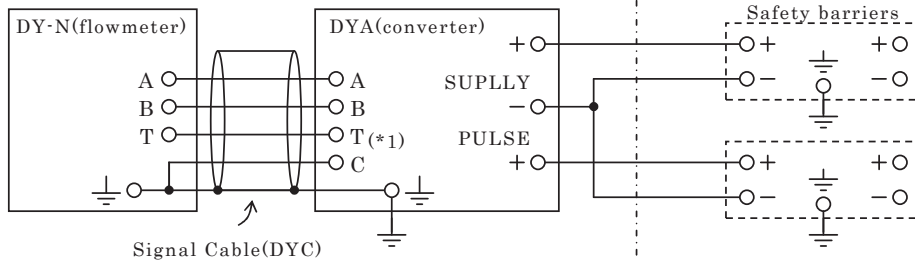

(*1) Wire for T terminal

With temperature sensor type : installed
Without temperature sensor type : not installed

Electrical parameters of vortex flowmeter(DY) and vortex flow converter(DYA).

$V_{max}=30\text{ V}$ $I_{max}=165\text{mA}$ $P_i=0.9\text{W}$
 $C_i=12\text{nF}$ $L_i=0.15\text{mH}$

Installation requirements between flowmeter, converter and Safety Barrier

Rev1 $V_t \text{ or } V_{oc} \leq V_{max}$ $I_t \text{ or } I_{sc} \leq I_{max}$ $P_o \leq P_i$
 $C_a \geq C_i + C_{cable}$ $L_a \geq L_i + L_{cable}$

$V_t, V_{oc}, I_t, I_{sc}, P_o, C_a$ and L_a are parameters of safety barrier.

Note :

1. In any safety barrier used output current must be limited by a resistor 'R' such that $I_{sc}=V_{oc}/R$.
- Rev2 2. Any Single FM Approved Barrier of multiple barriers FM Approved for this configuration who's parameters meet the above installation requirements.
3. Input voltage of the safety barrier must be less than $250V_{rms}/V_{dc}$.
- Rev2 4. Installation should be in accordance with National Electrical Code, ANSI/NFPA 70.
5. Dust-tight conduit seal must be used when installed in class II and III environments.
6. Do not alter drawing without authorization from FM.

Rev.1 :October 19, 2001 Y. Yamamoto
Rev.2 :November 5, 2001 Y.Yamamoto

Doc. No.: IFM019-A12 P.1
Drawing: Y. Yamamoto
Approved: K. Ichikawa

Yokogawa Electric Corporation

IFM019

Model: DY Series

Date: April 16, 2001

Nonincendive

Hazardous Location ← → Non Hazardous Location

Class I,II, Division 2,
Groups A,B,C,D,F and G,
Class III, Division 1,
and Class I, Zone 2, Group IIC

[Integral type]

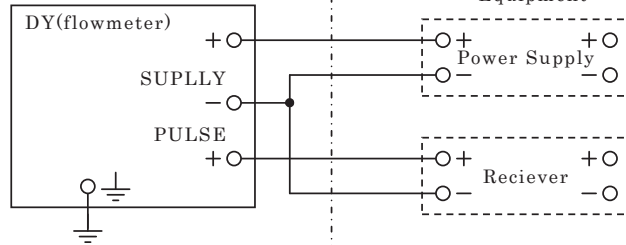

[Remote type]

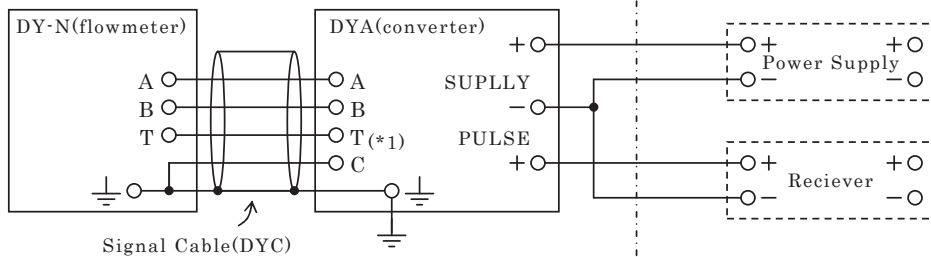

(*1) Wire for T terminal
With temperature sensor type : installed
Without temperature sensor type : not installed

Non-incendive field wire parameters of vortex flowmeter(DY) and vortex flow converter(DYA).

$V_{max}=30\text{ V}$ $I_{max}=165\text{mA}$ $P_i=0.9\text{W}$
 $C_i=12\text{nF}$ $L_i=0.15\text{mH}$

Installation requirements between flowmeter, converter and general purpose equipment.

[Rev1] $V_t \text{ or } V_{oc} \leq V_{max}$ $I_t \text{ or } I_{sc} \leq I_{max}$ $P_o \leq P_i$
 $C_a \geq C_i + C_{cable}$ $L_a \geq L_i + L_{cable}$

V_t , V_{oc} , I_t , I_{sc} , P_o , C_a and L_a are nonincendive field wire parameters of general purpose equipment.

Note :

- [Rev2] 1. The general purpose equipment must be FM Approved with Nonincendive field wiring parameter which meet the above installation requirements.
- [Rev2] 2. Installation should be in accordance with National Electric Code, ANSI/NFPA 70.
- 3. Dust-tight conduit seal must be used when installed in class II and III environments.
- 4. Do not alter drawing without authorization from FM.

Rev.1 :October 19, 2001 Y. Yamamoto
Rev.2 :November 5, 2001 Y.Yamamoto

Doc. No.: IFM019-A12 P.2
Drawing: Y. Yamamoto
Approved: K. Ichikawa

Yokogawa Electric Corporation

IFM019

14.3 IECEX



WARNING

- Only trained persons use this instrument in industrial locations.
- A modification of the equipment would no longer comply with the construction described in the certificate documentation.

(1) Technical Data

• Flameproof

Applicable Standard: IEC 60079-0:2011
IEC 60079-1:2014

Certificate: IECEX DEK 11.0077X

Type of Protection:

Ex db IIC T6...T1 Gb (Integral Type and Remote Type Detector)

Ex db IIC T6 Gb (Remote Type Converter)

Specification of Protection:

Temperature Class: (Integral Type and Remote Type Detector)

| Temperature Class | Process Temperature |
|-------------------|---------------------|
| T6 | -40°C to +80°C |
| T5 | -40°C to +100°C |
| T4 | -40°C to +135°C |
| T3 | -40°C to +200°C |
| T2 | -40°C to +300°C |
| T1 | -40°C to +450°C |

*1 Note: Use /HT version above +250°C

Temperature Class: T6 (Remote Type Converter)

Ambient Temperature:

-30 to +60°C (With indicator)

-40 to +60°C (Without indicator)

Power Supply: 10.5 to 42Vdc max.

Output Signal: Current Output; 4 to 20mA

Pulse output; On=2Vdc, 200mA

Off=42Vdc, 4mA

Specific conditions of use

- Electrostatic charges on the non-metallic parts (excluding glass parts) or coated parts of the equipment shall be avoided.
- The flameproof joints differ from the standard values in IEC 60079-1. Only personnel authorized by the manufacturer of the equipment can repair the flameproof joints.
- The property class of the fasteners used to fasten the sensor assembly part the transmitter enclosure is at least A2-50.

• Intrinsically Safe

Applicable Standard: IEC 60079-0:2011

IEC 60079-11:2011

IEC 60079-26:2006

Certificate: IECEX DEK 13.0066X

Type of protection:

Ex ia IIC T4...T1 Ga (Integral Type)

Ex ia IIC T6...T1 Ga (Remote Type Detector)

Ex ia IIC T4 Ga (Remote Type Converter)

Ambient Temperature:

-50 to +60°C (Integral Type)

-50 to +80 [+79]°C (Remote Type Detector)

(Option /LT below -29°C, [] for Option /MV at T6)

-50 to +80°C (Remote Type Converter)

Temperature Class:

(Integral Type)

| Temperature Class | Process Temperature |
|-------------------|---------------------|
| T4 | -50°C to +135°C |
| T3 | -50°C to +199°C |
| T2 | -50°C to +250°C |
| T1 | -50°C to +250°C |

(Remote Type Detector)

| Temperature Class | Process Temperature * |
|-------------------|-------------------------|
| T6 | -196°C to +84/[+79]°C |
| T5 | -196°C to +100°C |
| T4 | -196°C to +135°C |
| T3 | -196°C to +199°C |
| T2 | -196°C to +299/[+289]°C |
| T1 | -196°C to +449/[+439]°C |

*: Use /HT option above +250°C, use /LT option below -29°C, [] for /MV option.

Electrical data:

Supply and Output Circuit

(SUPPLY + and -, PULSE + and -);

Maximum Input Voltage Ui: 30 V dc

Maximum Input Current Ii: 300 mA

(Refer to Contact rating for pulse output.)

Maximum Input Power Pi: 0.9 W

Internal Capacitance Ci: 14nF

Internal Inductance Li: 0mH

Electrical Connection: ANSI 1/2 NPT female,

ISO M20 X 1.5 female

Specific conditions of use

- Electrostatic charges on the non-metallic parts (excluding glass parts) or coated parts of the equipment shall be avoided.
- When the enclosure of the flow meter or the converter are made of aluminum, if it is mounted in an area where the use of EPL Ga equipment is required, it must be installed such that, even in the event of rare incidents, ignition sources due to impact and friction sparks are excluded.
- The dielectric strength of at least 500 V a.c. r.m.s. between the intrinsically safe circuits and the enclosure of the flow meter or the converter is limited only by the overvoltage protection.

(2) Installation



WARNING

- Take care the following warning marking. "POTENTIAL ELECTROSTATIC CHARGING HAZARD"
- Electrostatic charge may cause an explosion hazard. Avoid any actions that cause the generation of electrostatic charge, such as rubbing with a dry cloth on coating face of the product.
- All wiring shall comply with IEC 60079-14, and local electric codes and requirements.
- In cases where the process temperature exceeds 200 °C, use external heat resistant cable and cable gland with a maximum allowable temperature of 90 °C or above.
- In case of Flameproof, Cable glands and/or adapters with a suitable temperature rating shall be of Ex db certified by IECEx.
- Cable gland and adapters shall be installed so as to maintain the specified degree of protection (IP Code) of the flowmeter.
- In order to prevent the earthing conductor from loosening, the conductor must be secured to the terminal, tightening the screw with appropriate torque. Care must be taken not to twist the conductor.

The grounding terminals are located on the inside and outside of the terminal area. Connect the cable to grounding terminal in accordance with wiring procedure (1) or (2).

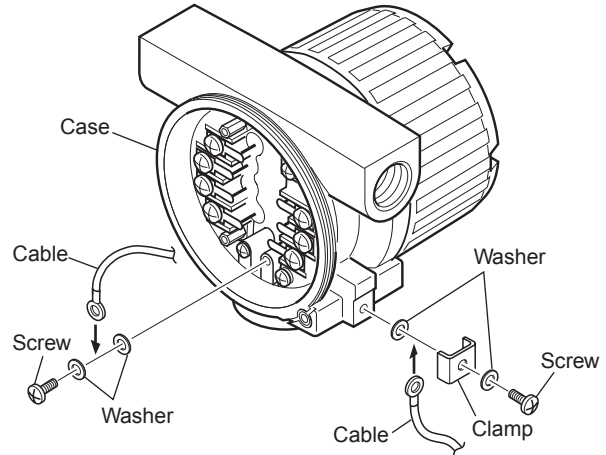

(1) Internal grounding terminal (2) External grounding terminal F1404.ai

Figure 14.2 Wiring Procedure for Grounding Terminals

(3) Operation



WARNING

- Take care the following warning marking. "POTENTIAL ELECTROSTATIC CHARGING HAZARD"
- Electrostatic charge may cause an explosion hazard. Avoid any actions that cause the generation of electrostatic charge, such as rubbing with a dry cloth on coating face of the product.
- Take care not to generate mechanical spark when access to the equipment and the peripheral devices in hazardous locations.
- In case of Flameproof, take care the following warning marking when opening the cover. "AFTER DE-ENERGIZING, DELAY 3 MINUTES BEFORE OPENING"

(4) Maintenance and Repair



WARNING

When maintenance and repair are performed, confirm the following conditions and then perform works. Confirm the power supply is cut off and the voltage of power supply terminal is not supplied. Only personnel authorized by Yokogawa Electric Corporation can repair the equipment in accordance with the relevant standards: EN 60079-19 (Equipment repair, overhaul and reclamation) and EN 60079-17 (Electrical installation inspection and maintenance).

(5) Installation Diagram of Intrinsically safe (and Note)

[Integral type]

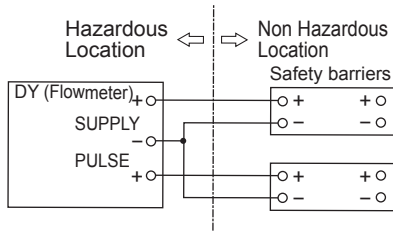

[Remote type without built-in Temperature sensor]

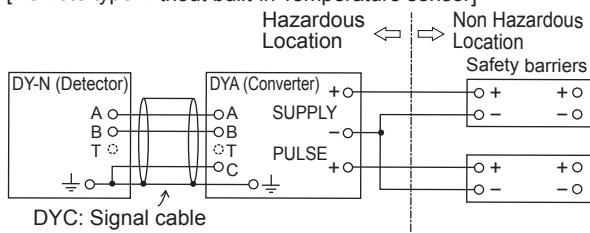

[Remote type with built-in Temperature sensor]

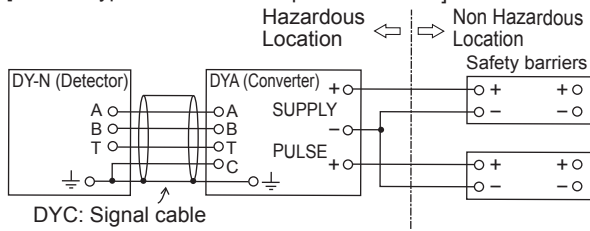

Electrical data:

Signal/Supply Circuit (Terminals SUPPLY + and -):
 $U_i = 30\text{ V}$, $I_i = 300\text{ mA}$, $P_i = 0.9\text{ W}$ (linear source),
 $C_i = 14\text{ nF}$, $L_i = 0\text{ mH}$

Pulse Circuit (Terminals PULSE + and -):
 $U_i = 30\text{ V}$, $I_i = 300\text{ mA}^*$, $P_i = 0.9\text{ W}$ (linear source),
 $C_i = 14\text{ nF}$, $L_i = 0\text{ mH}$

*: Refer to "Contact rating" for the maximum current value of Pulse Circuit

Note:

- It shall be assured that the voltage difference between the output circuits of the associated apparatus (safety barriers) is not more than 30V.
- Cables for the connection for Signal/Supply Circuit and Pulse Circuit shall be of Type A or B in accordance with IEC 60079-14, otherwise the sum of I_o of the associated apparatus (safety barriers) shall be not more than 300 mA.

F1405.ai

(6) Electrical Connection

The type of electrical connection is stamped near the electrical connection port according to the following codes.

| Screw size | Marking |
|----------------------|---------|
| ISO M20 X 1.5 female | ⚠ M |
| ANSI 1/2NPT female | ⚠ N |

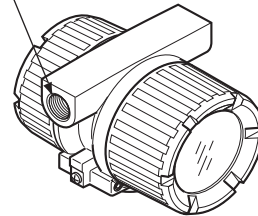

F1406.ai

(7) Name Plate

Example for name plates in case of "Flameproof, Integral type"

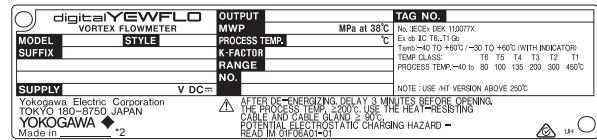

- MODEL: Specified model code
- SUFFIX: Specified suffix code
- STYLE: Style code
- SUPPLY: Supply voltage
- OUTPUT: Output signal
- MWP: Maximum working pressure
- PROCESS TEMP.: Process temperature
- K-FACTOR: Device-specific factor
- RANGE: Specified range
- NO.: Upper column: Manufacturing serial number
Lower column: The year and month of production
- TAG NO.: Specified TAG No.
- IECEx DEK 11.0077X: Certificate number*1
- Ex db IIC T6...T1 Gb: Type of Protection*1

- *1) Example for "Flameproof, Integral type"
- *2) The product - producing country

14.4 CSA

(1) Technical Data

• **Explosion Proof**

Applicable Standard: C22.1-98, C22.2 No.0-M1991, C22.2 No.0.4-04, C22.2 No.0.5-1982, C22.2 No. 25-1966, C22.2 No. 30-M1986, C22.2 No. 94-M1991, C22.2 No. 142-M1987, C22.2 No. 61010-1-04, ANSI/ISA-12.27.01-2003

Certificate: 1166201

Type of Protection:

Explosionproof for Class I, B, C and D; Class II, Groups E, F and G; Class III.

For Class I, Division 2 location:

“FACTORY SEALED, CONDUIT SEAL NOT REQUIRED.”

Enclosure: Type 4X

(Integral Type and Remote Type Detector)

| Temperature Code | Process Temperature |
|------------------|---------------------|
| T6 | ≤+85°C |
| T5 | ≤+100°C |
| T4 | ≤+135°C |
| T3 | ≤+200°C |
| T2 | ≤+300°C |
| T1 | ≤+450°C |

Temperature Code: T6 (Remote Type Converter)

Ambient Temperature: -50 to +60°C

Power Supply: 42Vdc max. (Integral Type and Remote Type Converter)

Output Supply (Integral Type):

Current Output; 4 to 20mA
Pulse Output; On=2Vdc, 200mA
Off=42Vdc, 4mA

Output Signal (Remote Type Detector):

Output Signal; 30Vp-p, 100µAp-p

Input/Output signal (Remote Type Converter):

Current Output; 4 to 20mA
Pulse; On=2Vdc, 20mA
Off=42Vdc, 4mA

Input Signal; 30Vp-p, 100µAp-p

Electrical Connection: ANSI 1/2 NPT female

• **Intrinsically Safe**

Type “n” and Non-incendive

Applicable Standard: C22.2 No. 0-M91, C22.2 No. 0.4-2004, C22.2 No. 157-M1987, C22.2 No. 213-M1987, C22.2 No. 1010.1-92, CAN/CSA-E60079-0:02, CAN/CSA-E60079-11:02, CAN/CSA-E60079-15:02, ANSI/ISA-12.27.01-2003

Certificate: 1198227

Type of Protection:

Ex ia IIC T4...T1 and Ex nC IIC T4...T1
(Integral Type and Remote Type Detector)

Ex ia IIC T4 and Ex nC IIC T4
(Remote Type Converter)

(Integral Type and Remote Type Detector)

| Temperature Code | Process Temperature |
|------------------|---------------------|
| T4 | ≤+135°C |
| T3 | ≤+200°C |
| T2 | ≤+300°C |
| T1 | ≤+450°C |

Ambient Temperature: -40 to +60°C

Degree of Protection of Enclosure: IP67

Electrical Parameters: Ui=30Vdc, Ii=165mA, Pi=0.9W

Ci=12nF, Li=0.15mH

Electrical Connection: ANSI 1/2 NPT female

Type of Protection:

Intrinsically Safe for Class I, II, III, Div.1, Groups A, B, C, D, E, F and G, Non- incendive for Class I, II, Div.2, Groups A, B, C, D, F and G, Class III, Div.1

(Integral Type and Remote Type Detector)

| Temperature Code | Process Temperature |
|------------------|---------------------|
| T4 | ≤+135°C |
| T3 | ≤+200°C |
| T2 | ≤+300°C |
| T1 | ≤+450°C |

Temperature Code: T4 (Remote Type Converter)

Ambient Temperature: -40 to +60°C

Enclosure: Type 4X

Electrical Parameters: Vmax=30Vdc, Imax=165mA, Pmax=0.9W, Ci=12nF, Li=0.15mH

(2) Wiring

• **Explosion proof**



WARNING

- All wiring shall comply with Canadian Electrical Code Part I and Local Electrical Codes.
- In Hazardous locations, wiring shall be in conduit as shown in the figure.
- A SEAL SHALL BE INSTALLED WITHIN 50cm OF THE ENCLOSURE.
- When the equipment is installed in Division 2, "FACTORY SEALED, CONDUIT SEAL NOT REQUIRED".

(3) Operation

• **Explosion proof**



WARNING

- In case of Explosion protected type, note a warning label worded as follows.
Warning: OPEN CIRCUIT BEFORE REMOVING COVER.
- Take care not to generate mechanical spark when access to the instrument and peripheral devices in hazardous locations.

(4) Maintenance and Repair



WARNING

Only personnel authorized by Yokogawa Electric Corporation can repair the equipment.

(5) Installation Diagram Intrinsically Safe (and Note)

Intrinsically safe

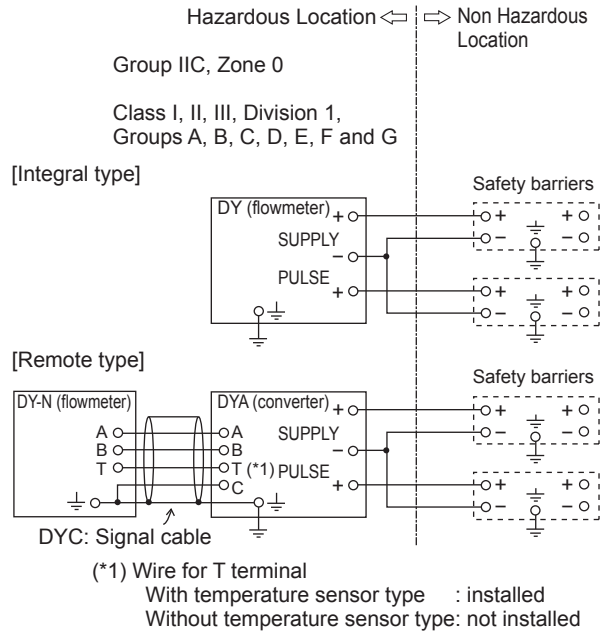

Electrical parameters of vortex flowmeter (DY) and converter (DYA).

U_i (V_{max})=30 V I_i (I_{max})=165 mA P_i (P_{max})=0.9W
C_i=12 nF L_i=0.15 mH

Installation requirements between flowmeter, converter and Safety Barrier

U_o ≤ U_i I_o ≤ I_i P_o ≤ P_i C_o ≥ C_i+C_{cable}
L_o ≥ L_i+L_{cable}
V_{oc} ≤ V_{max} I_{sc} ≥ I_{max} C_a ≥ C_i+C_{cable}
L_a ≥ L_i+L_{cable}

U_o, I_o, P_o, C_o, L_o, V_{oc}, I_{sc}, C_a and L_a are parameters of barrier.

F1407.ai



WARNING

- In any safety barrier used output current must be limited by a resistor 'R' such that I_o=U_o/R or I_{sc}=V_{oc}/R.
- The safety barrier must be CSA certified.
- Input voltage of the safety barrier must be less than 250V_{rms}/V_{dc}.
- Installation should be in accordance with Canadian Electrical Code Part I.
- Dust-tight conduit seal must be used when installed in class II and III environments.
- Do not alter drawing without authorization from CSA.

Type “n” and Non-incendive

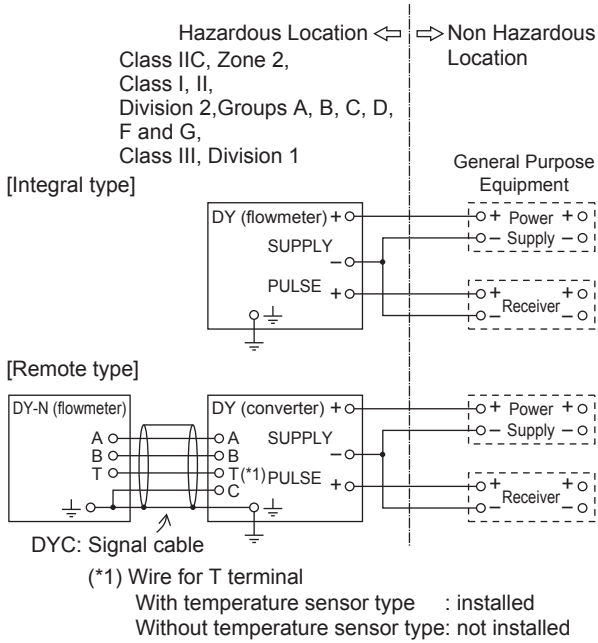

Non-incendive field wire parameters of vortex flowmeter (DY) and converter (DYA).

$U_i (V_{max})=30$ $I_i (I_{max})=165mA$ $P_i (P_{max})=0.9W$
 $C_i=12nF$ $L_i=0.15mH$

Installation requirement between flowmeter, converter and general purpose equipment.

$U_o \leq U_i$ $I_o \leq I_i$ $P_o \leq P_i$ $C_o \geq C_i + C_{cable}$
 $L_o \geq L_i + L_{cable}$
 $V_{oc} \leq V_{max}$ $I_{sc} \leq I_{max}$ $C_a \geq C_i + C_{cable}$
 $L_a \geq L_i + L_{cable}$

$U_o, I_o, P_o, C_o, V_{oc}, I_{sc}, C_a$ and L_a are nonincendive field wire parameters of general purpose equipment.

F1408.ai



WARNING

- The general purpose equipment must be CSA certified as the equipment which have type n or non-incendive field wire parameters.
- Installation should be in accordance with Canadian Electrical Code Part I.
- Dust-tight conduit seal must be used when installed in class II and III environments.
- Do not alter drawing without authorization from CSA.

(6) Dual Seal (Option code: /CF11, /CS11)

Dual Seal:

Certified by CSA to the requirement of ANSI/ISA 12.27.01

No additional sealing required.

Primary seal failure annunciation: at the O-ring seal portion between shedder bar and amplifier housing.

14.5 TIIS

Certificate:

| Model | Shedder bar Material | Integral Type Flowmeter | | Remote Type Detector |
|-------------------------------|----------------------|-------------------------|--------------------|----------------------|
| | | N (None Indicator) | D (With Indicator) | N (None Indicator) |
| DY015 DY025/R1 DY040/R2 | E | TC14901 | TC14912 | TC14923 |
| | X | TC18903 | TC18914 | TC18925 |
| DY025 DY040/R1 DY050/R2 | E | TC19504 | TC19513 | TC19522 |
| | X | TC18904 | TC18915 | TC18926 |
| DY040 DY050/R1 DY080/R2 | E | TC19505 | TC19514 | TC19523 |
| | X | TC18905 | TC18916 | TC18927 |
| DY050 DY080/R1 DY100/R2 | E | TC19506 | TC19515 | TC19524 |
| | X | TC18906 | TC18917 | TC18928 |
| DY080 DY100/R1 DY150/R2 | E | TC19507 | TC19516 | TC19525 |
| | X | TC18907 | TC18918 | TC18929 |
| DY100 DY150/R1 DY200/R2 | E | TC19508 | TC19517 | TC19526 |
| | X | TC18908 | TC18919 | TC18930 |
| DY150 DY200/R1 | E | TC19509 | TC19518 | TC19527 |
| | X | TC18909 | TC18920 | TC18931 |
| DY200 | E | TC19510 | TC19519 | TC19528 |
| | X | TC18910 | TC18921 | TC18932 |
| DY250 | E | TC19511 | TC19520 | TC19529 |
| DY300 | E | TC19512 | TC19521 | TC19530 |
| DY400 | B | TC18945 | TC18955 | TC18965 |
| Model | Shedder bar Material | Remote Type Converter | | |
| | | N (None Indicator) | D (With Indicator) | |
| DYA | | TC14934 | TC14935 | |

| | Integral Type Flowmeter | | Remote Type Flowmeter | |
|---------------------|--|----------------|---|--|
| | None Indicator | With Indicator | Detector | Converter |
| Construction | Ex d IIC T6 | ← | ← | ← |
| | Flame Proof Approval | ← | ← | ← |
| Amb.Temp | -20°C up to +60°C | ← | ← | ← |
| Rating | Maximum power supply vortage: DC42V Current Signal: DC4-20mA Pulse Signal: ON : 2V 200mA OFF : 42V 4mA | | Output Voltage: 30Vp-p Output Current: 100µ Ap-p | Maximum power supply vortage: DC42V Current Signal: DC4-20mA Pulse Signal: ON : 2V 200mA OFF : 42V 4mA Input Signal: 30V p-p,100µ A p-p Resistance Temp, Sensor Input: Pt1000 at 0°C Specified Current: less than 1mA |

* In case that ambient temperature exceeds 50°C, use heat-resistant cables with maximum allowable temperature of 70°C or above.

15. PED (PRESSURE EQUIPMENT DIRECTIVE)

This chapter is described further requirements and notices concerning the PED (Pressure Equipment Directive). The description in this chapter is prior to other description in this User's Manual.

(1) Technical Data

Pressure Equipment Directive:

Type of equipment: Pressure accessory – Piping

Type of fluid: liquid and gas

Group of fluid: 1 and 2

Module: H

| MODEL | DN (mm)* | PS* | | PS-DN | | CATEGORY** |
|-------|-------------|-------|-------|----------|----------|-------------------------------------|
| | | (bar) | (MPa) | (bar·mm) | (MPa·mm) | |
| DY015 | 15 | 420 | 42 | 6300 | 630 | Sound Engineering Practice (SEP)*** |
| DY025 | 25 | 420 | 42 | 10500 | 1050 | Sound Engineering Practice (SEP)*** |
| DY040 | 40 | 420 | 42 | 16800 | 1680 | II**** |
| DY050 | 50 | 420 | 42 | 21000 | 2100 | II**** |
| DY080 | 80 | 420 | 42 | 33600 | 3360 | II**** |
| DY100 | 100 | 420 | 42 | 42000 | 4200 | II**** |
| DY150 | 150 | 420 | 42 | 63000 | 6300 | III |
| DY200 | 200 | 420 | 42 | 84000 | 8400 | III |
| DY250 | 250 | 420 | 42 | 105000 | 10500 | III |
| DY300 | 300 | 420 | 42 | 126000 | 12600 | III |
| DY400 | 400 | 250 | 25 | 100000 | 10000 | III |

* PS: Maximum allowable pressure for Flow tube, DN: Nominal size

** Table 6 covered by ANNEX II of Directive 2014/68/EU

*** Article 4, paragraph 3 of Directive 2014/68/EU

**** MODELS classified in CATEGORY II shall not be used for unstable gases of Group 1.

CE marking:

CE marking is attached for non-Explosion protected type(Note1) and ATEX Explosion protected type.

The product which is attached CE marking is in conformity with the statutory requirements of the applicable EU Directives.

Note 1: /HX2(Anti-Corrosion Version I) of DY150 is not PED compliant. CE marking is not attached.

EU RoHS Directive:

EN 50581

(2) Installation



WARNING

- Please tighten the bolts for piping joint according to the appropriate torque values.
- Please take measure to protect the flowmeters from forces caused by vibration through piping.

(3) Operation



WARNING

- The temperature and pressure of fluid should be applied under the normal operating condition.
- The ambient temperature should be applied under the normal operating condition.
- Please pay attention to prevent the excessive pressure like water hammer, etc. When water hammer is to be occurred, please take measures to prevent the pressure from exceeding PS (maximum allowable pressure) by setting the safety valve, etc. at the system and the like.
- When external fire is to be occurred, please take safety measures at the device or system not to influence the flowmeters.
- Please pay attention not to abrade the metal pipe, when using the fluid to abrade the metal pipe such as slurry and sand are contained.

INSTALLATION AND OPERATING PRECAUTIONS FOR FLAMEPROOF ENCLOSURE “d” CERTIFIED UNDER JAPANESE TYPE CERTIFICATION

1. General

The following describes precautions on electrical equipment protection by flameproof enclosure “d” for use in explosive atmospheres (hereinafter referred to as Flameproof enclosure “d” equipment). Following the Labor Safety and Health Laws of Japan, flameproof enclosure “d” equipment is an electrical equipment which has Type Approval by Japanese certification body according to Ordinance No.45 of 30 September 1972 and the latest amendment: Ordinance No. 121 of 30 June 2016 by the Japanese Ministry of Health, Labor and Welfare. These certified equipment can be used in explosive atmospheres.

Certified equipment includes a certification label, an equipment nameplate with the necessary specifications, and warning labels for Flameproof enclosure “d”. Please confirm these precautionary items and use the equipment to meet specification requirements.

For electrical wiring and maintenance servicing, read USER’S GUIDELINES for Installations for Explosive Atmospheres in General Industry.

2. Electrical equipment protection by flameproof enclosures “d”

Flameproof enclosure “d” has an enclosure(s) in which the parts which can ignite an explosive gas atmosphere are placed and which can withstand the pressure developed during an internal explosion of an explosive mixture, and which prevents the transmission of the explosion to the explosive gas atmosphere surrounding the enclosure.

In this manual, the word ‘ flameproof enclosure “d” ‘ is applied to the flameproof equipment combined with the types of protection increased safety “e”, oil immersion safety “o”, intrinsic safety “I”, and special protection “s”, as well as flameproof enclosure “d”.

3. Terminology

(1) Enclosure

It contains all the walls, doors, covers, cable glands, rods, spindles, shafts, etc. which contribute to the Type of Protection or the degree of protection IP of the equipment.

(2) Enclosure internal volume

It is total internal volume of the enclosure in which the contents are essential in service, the volume to be considered is the remaining free volume.

(3) Width of flameproof joint

It is shortest path through a flameproof joint from the inside to the outside of an enclosure. This definition does not apply to threaded joints.

(4) Gap of flameproof joint

It is distance between the corresponding surfaces of a flameproof joint when the electrical apparatus enclosure has been assembled. For cylindrical surfaces, forming cylindrical joints, the gap is the difference between the diameters of the bore and the cylindrical component.

4. Installation of Flameproof Equipment

(1) Installation Area

Flameproof equipment may be installed, in accordance with applicable gases, in a hazardous area in Zone 1 or 2, where the specified gases are present. Those equipment shall not be installed in a hazardous area in Zone 0.

Note: Hazardous areas are classified in zones based upon the frequency of the appearance and the duration of an explosive gas atmosphere as follows:

Zone 0: Place in which an explosive atmosphere consisting of a mixture with air of flammable substances in the form of gas or vapour is present continuously or for long periods or frequently.

Zone 1: Place in which an explosive atmosphere consisting of a mixture with air of flammable substances in the form of gas or vapour is likely to occur in normal operation occasionally.

Zone 2: Place in which an explosive atmosphere consisting of a mixture with air of flammable substances in the form of gas or vapour is not likely to occur in normal operation but, if it does occur, will persist for a short period only.

(2) Environmental Conditions

To comply with the ambient temperature range which indicated on the nameplate. If the flameproof equipment are exposed to direct sunshine or radiant heat from plant facilities, appropriate thermal protection measures shall be taken.

5. External Wiring for Flameproof Equipment

Flameproof equipment requires cable wiring for their electrical connections. For cable wiring, cable glands (cable entry devices for flameproof type) to wiring connections shall be attached. All non-live metal parts such as the enclosure shall be securely grounded. For details, read USER'S GUIDELINES for Installations for Explosive Atmospheres in General Industry.

(1) Cable Wiring

- For cable wiring, Ex cable glands attached (or supplied) with the electrical equipment of Flameproof enclosure shall be used and connected to conduit.
- Specific cables shall be used as recommended by the USER'S GUIDELINES for Installations for Explosive Atmospheres in General Industry.
- In necessary, appropriate protective pipes (conduit or flexible pipes), ducts or trays shall be used for preventing the cable run (outside the cable glands) from damage.
- To prevent explosive atmosphere from being propagated from Zone 1 or 2 hazardous location to any different location or non-hazardous location through the protective pipe or duct, apply sealing of the protective pipes near the individual boundaries, or fill the ducts with sand appropriately.
- When branch connections of cables or cable and conduit wiring is made, a flameproof connection box shall be used. In this case, flameproof cable glands meeting the type of connection box must be used for cable connections to the box.



IMPORTANT

The electrical equipment of Flameproof enclosure is certified to be used with the attached Ex cable gland(s). Therefore, the attached Ex cable gland(s), Yokogawa-specified Ex cable gland, shall be used to satisfy this requirement.

6. Maintenance of Flameproof Equipment

To maintain the flameproof equipment, do the following. For details, read USER'S GUIDELINES for Installations for Explosive Atmospheres in General Industry.

(1) Maintenance servicing with the power on.

Flameproof equipment shall not be maintenance-serviced with its power turned on. However, in cases where maintenance servicing is to be conducted with the power turned on, with the equipment cover removed, always shall use a gas detector to check that there is no explosive gas in that location. If it cannot be checked whether an explosive gas is present or not, maintenance servicing shall be limited to the following two items:

- (a) Visual inspection
Visually inspect the flameproof equipment, metal conduits, and cables for damage or corrosion, and other mechanical and structural defects.
- (b) Zero and span adjustments
These adjustments should be made only to the extent that they can be conducted from the outside without opening the equipment cover. (e.g. by software) In doing this, great care must be taken not to cause mechanical sparks with tools.

(2) Repair

If the flameproof equipment requires repair, turn off the power and transport it to a safety (non-hazardous) location. Observe the following points before attempting to repair the equipment.

- (a) Make only such electrical and mechanical repairs as will restore the equipment to its original condition. For the flameproof equipment, the gaps and path lengths of joints and mating surfaces, and mechanical strength of enclosures are critical factors in explosion protection. Exercise great care not to damage the joints or shock the enclosure.
- (b) If any damage occurs in threads, joints or mating surfaces, inspection windows, connections between the sensor and terminal box or clamps, or external wiring connections which are essential in flameproof, contact Yokogawa Electric Corporation.



CAUTION

Do not attempt to re-process threaded connections or refinish joints or mating surfaces.

- (c) If you attempt to repair the flameproof equipment, company-specified components shall be used.
- (d) Before starting to service the equipment, be sure to check all parts necessary for retaining the requirements for flameproof equipment. For this, check that all screws, bolts, nuts, and threaded connections have properly been tightened.

(3) Prohibition of specification changes and modifications

Do not attempt to change specifications or make modifications involving addition of or changes in external wiring connections.

References:

- (1) Recommended Practices for Explosion-Protected Electrical Installation in General Industries.
- (2) USER'S GUIDELINES for Installations for Explosive Atmospheres in General Industry.

Revision Information

- Title: Model DY Vortex Flowmeter
Model DYA Vortex Flow Converter
- Manual No.: IM 01F06A00-01EN

| Edition | Date | Page | Revised Item |
|---------|-----------|---|---|
| 3rd | Jun. 2002 | 1-1 2-2 2-3 2-5 2-6, 2-7 2-9 2-10 4-2 6-1 6-6 6-10 7-3 9-1 9-3 9-4 9-5 9-6 9-8 9-10 9-11 10-1 | 1.1 Change Figure 1.1(b). 2.2 Change the process temperature range and ambient temperature. 2.2 Add Pressure Equipment Directive, Change Figure 2.2.1. 2.3 Change Table 2.3.1 "Body" of Cryogenic Version. 2.4 Change the process temperature range and ambient temperature. 2.4 Change the process temperature range. 2.4 Change Figure 2.4.1 , 2.4.2. 4.2 Add the description of Table 4.1. 6.3 Change the contents of parameter lists. 6.3 Change a table of parameter list. 6.4 Add the description of "B50 A/OUT SELECT". 7.2.2 Change a tuning method. 9.1.1 Change the process temperature and ambient temperature. 9.1.6 Change Data Plate. 9.2.1 Change the process temperature and ambient temperature. 9.2.5 Correct "WARNING" and Installation Diagram of Non incendive. 9.2.6 Change Data Plate. 9.4.1 Change the process temperature and ambient temperature. 9.4.5 Correct the Installation Diagram of Non incendive. 9.4.6 Change Data Plate. 10 Change the technical data. |
| 4th | Sep. 2003 | 2-4 2-5 2-8, 2-9 2-11 3-10 4-1 4-3 5-9 | 2.3 Add BS1 to 5. Table 2.3.2 Add BS1 to 5. 2.4 Add Hydrostatic Pressure Test, etc. 2.5 Table 2.5.1 Change the value for size 40 mm. 3.7.3 Add the description. 4.2 Figure 4.2 Add the description. 4.4 Figure 4.5 Add the description. 5.5 Figure 5.5 Add the description. |
| 5th | Apr. 2004 | i iv vi 1-1 2-1/22 3-1/10 3-9 3-10 4-1/6 4-4/5 5-1/24 6-1/17 7-1/4 9-1/11 10-1 8-5/6 8-7/8 | CONTENTS Reconfiguration. Add symbol mark, revision. Revision. Revision. Revision of Specification, Move to Chapter 9. Revision, Move to Chapter 2. Revision, Move to Chapter 7. Add IMPORTANT, Revision, Move to Chapter 7. Move to Chapter 3. Revision, Move to Chapter 3. Revision, Move to Chapter 4. Revision, Move to Chapter 5. Change Chapter name MAINTENANCE to OPERATION. Revision, Move to Chapter 10. Move to Chapter 11. 8.3 moves to Chapter 7. 8.4 moves to Chapter 7. |
| 6th | Jan. 2005 | 5-6 5-8 5-16 9-5 9-8 9-13 9-18/25 10-7 10-8 10-9 | Correction. Added a parameter. Added a parameter explanation and corrections. Revision (MS code). Revision (Option Specification). Revision. Revision. Revision. Revision. Revision. Revision. |
| 7th | July 2005 | 2-5 7-8 9-3 9-6 10-1/13 | Added a "CAUTION" about heat insulating material installation. Revised the formula 7.14.3. Changed the EMC Conformity Standards No.. Deleted DIN64 and DIN100 (Suffix Code: BD5 and BD6). Added Applicable Standard No. and Certificate No. to each Approval body. |

| Edition | Date | Page | Revised Item |
|---------|-----------|--|---|
| 8th | Nov. 2005 | 2-7 3-5 4-21-25 4-24 5-15 5-16 8-2 9-5 9-6 9-7 9-8 9-10 9-11 9-12 9-14 9-19 9-20 9-22 9-23 9-24 | Revision: Vertical Installation. Revision: 7. Revision. Revision <K36>. H27: Revision. J10, J20: Revision. Revision. Revision of specification. Revision of specification. Revision of specification. Revision of specification. Table 9.4.3: Revision. Revision of specification. Revision of specification. Table 9.5.1: Revision. Tables: Revision. Tables: Revision. Tables: Revision. Tables: Revision. Revision. |
| 9th | May 2006 | 2-2 2-3 3-4 4-9 5-1 5-5 5-13 5-14 7-2 7-3 7-5 Chap.9 | Revision. Add a note to "Valve position (T-type pipe exist)" and "Heat - Insulation". Revision: Figure 3.6. Revision: Figure 4.5. Add a "IMPORTANT" to 5.2. Add Data Range to <E20>. Add descriptions to <E20>. Add a "IMPORTANT" to <F52>. Revision figures. Revision figures. Revision figures. Revision, Added optional items, etc. |
| 10th | Nov. 2006 | 2-2 4-14 5-13 7-1 7-4 9-5 9-6 9-7 9-8 9-9 9-10 9-11 9-14 9-15 9-16 9-17 9-18 9-27 9-28 9-29/30 10-4 10-13 | Add descriptions of /R2. Delete 4.6.2. Delete a note. Add to CAUTION. Add to CAUTION. Revisions. Add /R2. Add /R2. Revisions. Revision. Add /R2. Revisions. Add /R2. Add /R2. Add /R2. Add /R2. Add /R2. Revisions. Revisions. Add /R2. Revision. Revisions. |
| 11th | Aug. 2008 | 3-3 4-1 4-21 5-2 to 8 5-11 5-13 5-14 6-1 7-4 7-5 7-7, 8 9-11 to 13 9-14, 15 9-16 10-1 to 12 | Additions. Additions. Additions. Additions. Additions. Additions. Revisions of Figure 6.1. Additions of Table 7.1. Revisions of Figure 7.3. Corrections. Additions. Revisions. Corrections. Chap.10 Revisions. |

| Edition | Date | Page | Revised Item |
|---------|-----------|---|---|
| 12th | Mar. 2010 | 1-1 2-5 2-7 3-2 3-3 3-4 4-9 4-13 to 21 5-4 5-8 5-12 5-15 6-1 6-3 9-2 9-5 to 9-6 9-7 to 9-8 9-9 9-16 9-6 to 9-37 10-11 | Figure 1 Revision. 2.4 Revision. Table 2.3 Revision. Figure 3.2 Revision. Table 3.1 Revision. Figure 3.5 Revision. Figure 4.4 Revision. 4.6 Revision. D10 Revision. K45 Revision. NOTE Revision. NOTE Revision. NOTE Revision. 6.2.1 Revision. 9.2 Revision. 9.3 Revision. 9.4.1 Revision and add an option specification. 9.4.2 Revision. Revision. Revision and add /E1 drawings. 10.5 Revision. |
| 13th | Dec. 2011 | 5-12 5-15 10-1 10-2 10-3-1 10-3-2 vi 4-1 5-13 7-4 7-6 9-2 9-5 9-6 9-7 9-10 9-11/14 10-1/12 EX-B03E_2 | Manual Change No. 10-005-1E Add note (6). Revision and delete (Table 4.1) Revision (E30) Revision (Table 7.4) Revision (7.6 title) Revision (Specification changes) Revision (Specification changes, add MS Code) Revision (Specification changes, Table 9.3.1) Page alignment Table 9.3.2 Revision (Specification changes, Table for MV) Revision (Specification changes, for Explosion proof) Revision (Specification changes, for Explosion proof) Revision (Specification changes, for TIIS Explosion proof) |
| 14th | Mar. 2012 | vi 1-1 2-6 3-3 5-5 5-7 5-8 5-12 5-13, 14 5-16 Chapter 7 Chapter 8 9-1 9-2 10-2 10-4 10-7 Chapter 12 Chapter 13 | Add Warning; Wet location Correction (Chapter No.) Correction (Chapter No.) Add Note, *3 Correction (unit) Correction (time unit) Correction (K45) Add parameter item D40, Correction D43 Correction (unit) Revision (J40) Revision (HART5 and DTM menu tree) Add HART7 Add Note Minor amendment (ex.Chapter number) Revision 10.1 Revision (10.5 Vortex Shedder Removal) Add Footnote Add HART7, Revision of Ex-proof descriptions Revision of Ex-proof descriptions |

| Edition | Date | Page | Revised Item |
|---------|-----------|---|---|
| 15th | Aug. 2012 | 2-3 2-5 3-7, 3-8 5-2, 5-4, 5-5, 5-15 7-5 7-7 8-7, 8-8 8-15 8-18 8-19 10-2 10-4 10-6 12-3 12-5 12-6 12-8 12-9 12-11 12-12 to 12-14 12-15 12-19 12-20 to 12-38 13-1, 13-2, 13-4 13-5 13-7, 13-8 13-12 | Correction (Figure, Word) Correction (Word) Correction Correction Correction (Word) Add (RW) Correction Correction (Word) Add (RW) Add (R) Revision Revision (Table 10.1) Correction Add table. Revision Revision Revision Revision (Note7, 8, 9) Correction Revision (Explosionproof) Add DY250/HT and DY300/HT Revision Revision Revision for ATEX Correction for FM Add IECEx explosion proof Revision for the table of IECEx. |
| 16th | Oct. 2013 | Contents 1-3 3-1 to 3-4 4-3 to 4-4 4-8 4-9 6-1 to 6-10 6-11 6-15 6-19 11-2 11-4 11-6 13-1 to 13-41 14-1 to 14-4 14-4 to 14-6 14-14 15-1 | Corrected Added to Trademarks Added to DY400 Corrected Section 4.3 Deleted ATEX Type n Added to Figure 4.12 Added to DY400 Added to description in parameter number A30 Added to description in parameter number E10 Added to description in parameter number K45 Added to description for changing the converter and the terminal box orientation Added to DY400 Corrected Figure 11.4 Revised Chapter 13 Deleted ATEX Type n Corrected FM Added to DY400 Corrected Chapter 15 |
| 17th | Feb. 2014 | 4-1 4-2 4-4 4-8 11-1 11-2 11-4 13-1 13-2 13-3 13-5 13-9 13-11 13-20 13-21 13-22/40 14-1/4 14-7/8 14-9 14-15 15-1 | Add CAUTION Add descriptions 4.2 Add *5 4.6 Delete SAA Intrinsically Safe Approval 11 Delete SAA Intrinsically Safe Approval 11.1 Delete SAA Intrinsically Safe Approval Change Table 11.1 Torque Value Change Degree of Protection, Revision Add *1 to Contact rating Change PED descriptions Change *10 Change Note 8 and 9, Figure 13.5 Revise Note 1 Add Note(*), Revise ATEX Intrinsically Safe Approval Delete SAA Intrinsically Safe Approval, Add IECEx Intrinsically Safe Approval Delete Locking Screw descriptions Change ATEX Intrinsically Safe Approval descriptions Add Control Drawing descriptions Delete SAA Intrinsically Safe Approval, Add IECEx Intrinsically Safe Approval Revise TIIS Certification table Revise PED descriptions |

| Edition | Date | Page | Revised Item |
|---------|-----------|--|---|
| 18th | Oct. 2014 | 6-2/10 7-1 13-1 13-6, 7 13-8 13-9 13-13 13-21, 14-12 13-27, 30 13-24 | Bind Manual Change No.14-011V-E 6.3 Improve the table of Parameter List 7.1 Add IMPORTANT 13.1 Add an item to Ambient Temperature Range Table 13.1, 13.2 Improvements of Tables Add Applicable Model to WP Revise Note9 13.5 Add Note2 Revise Ambient Temperature of CS1 Revise a title Revise as same as SD 01F06A00-03EN |
| 19th | Nov. 2015 | 3-3 13-1/2 13-3 13-5 13-7 13-8/13 13-19 13-20/21 13-23, 24, 26, 27, 35, 36 14-1/14 15-1 | Revise Pressure and Temperature Taps Change words (refer → read) Revise PED Add Suffix Codes Add Flanges (R13) to Table 13.2 Correct/Change words Add ■ Error that is due to the pressure change Correct/Change words Add Flanges (R13) Correct/Change words Revise Ambient Temperature Revise PED |
| 20th | Oct. 2018 | 1-2 1-4 4-8 4-9 13-1 13-3 13-5 13-24 14-1 14-6, 14-10, 14-13 14-10, 14-13, 14-14 15-1 | Take in Manual Change No.17-0023-E and revisions of the related descriptions of the style code (product carrier code). WARNING (1),(3) and (4) Delete 1.3 Delete Table 4.2 Add (6) Revise Non-Wetted Parts, Change paint color, etc. Update CE Marking Add Note16 Revise values of dimension Update ATEX, Small corrections Revise WARNING (4) Alignment of words to "converter" Update PED |
| 21th | Aug. 2019 | 4-3, 4-4 13-3 13-5, 13-6, 13-7, 13-8, 13-9, 13-11 13-14 13-20 13-21 13-24 13-36 14-1 to 14-4 14-9 to 14-14 15-1 | Add "Communication medium" to Table 4.1. Add Note1 to CE marking, revise PED. Add Morocco Conformity Mark. Add Anti-Corrosion Version I (/HX1, /HX2, /HX3). Add ANSI Class 1500 Flange (BA6, CA6) Add Stainless steel plated with silver gasket (/SPG) Revise "of Rate" to "of Reading". Revise ATEX. Revise IECEx. Add Note4. Add Note2. Revise ATEX. Revise IECEx. Revise PED. |