

SFU

Gas Sampling System

Installation, Operation, Maintenance

SICK
Sensor Intelligence.

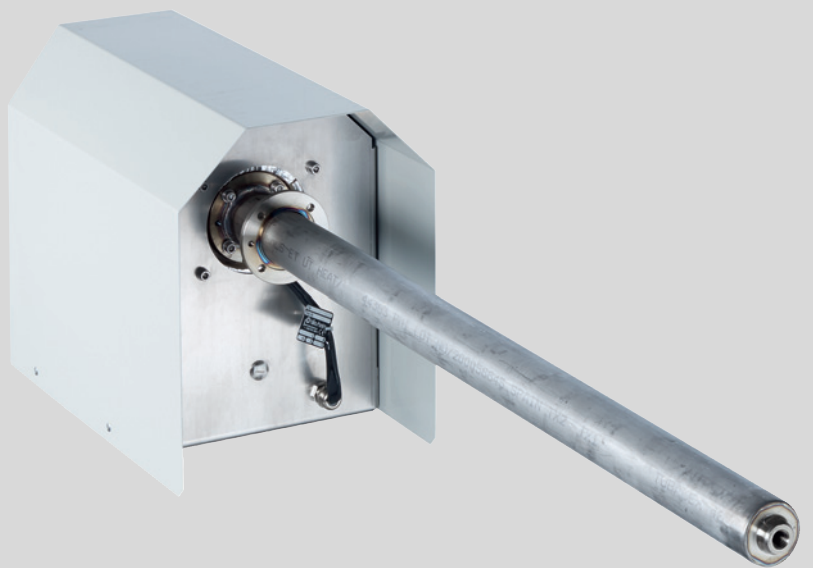

Described product

SFU (Gas Sampling System)

Variants:

- Filter Unit SFU-BF NI
- Filter Unit SFU-3V NI
- Filter Unit SFU-BF NI GL

Manufacturer

SICK AG
Erwin-Sick-Str. 1
79183 Waldkirch, Germany
Germany

Legal information

This work is protected by copyright. Any rights derived from the copyright shall be reserved for SICK AG. Reproduction of this document or parts of this document is only permissible within the limits of the legal determination of Copyright Law. Any modification, expurgation or translation of this document is prohibited without the express written permission of SICK AG.

The trademarks stated in this document are the property of their respective owner.

© SICK AG. All rights reserved.

Original document

This document is an original document of SICK AG.



Contents

1	About this document.....	5
1.1	Function of this document.....	5
1.2	Target group.....	5
1.3	Symbols and document conventions.....	5
1.3.1	Warning symbols.....	5
1.3.2	Warning levels / signal words.....	6
1.3.3	Information symbols.....	6
2	Safety information.....	7
2.1	Basic safety information.....	7
2.2	Warnings on the device.....	7
2.3	Intended use.....	7
2.4	Qualification of the operator.....	7
3	Product description.....	9
3.1	Product identification.....	9
3.2	Warnings on the device.....	10
3.3	Product description.....	11
3.4	Design.....	12
3.4.1	Probe tube.....	12
4	Installation and start-up.....	14
4.1	Important information.....	14
4.2	Weatherproof cover.....	15
4.3	Preparing the tube bundle cable.....	16
4.4	Mounting.....	16
4.4.1	Installing the welding neck flange.....	16
4.4.2	Connection of sample gas line.....	18
4.4.3	Connection of the pneumatic lines.....	19
4.5	Electrical installation.....	21
4.6	Installing the probe tube on the gas sampling filter.....	23
4.7	Installing the SFU on the welding neck flange.....	24
5	Maintenance.....	25
5.1	Important Information.....	25
5.2	Maintenance plan.....	25
5.3	Spare parts.....	26
5.4	Replacing the Sinter fine filter.....	26
5.5	Replacing the glass fiber fine filter.....	29
5.6	Retrofitting the fine filter.....	32
5.7	Checking for correct operation.....	35
6	Troubleshooting.....	36
6.1	Troubleshooting.....	36

7	Disposal.....	37
8	Technical data.....	38
8.1	Compliances and Standards.....	38
8.2	Dimensions.....	38
8.3	Operating data.....	39
9	Index.....	41

1 About this document

1.1 Function of this document

These Operating Instructions describe:

- Device components
- Installation
- Operation
- Maintenance work required for reliable operation

1.2 Target group

This document is addressed to technicians (persons with technical understanding) installing, operating and maintaining the measuring system.

Responsibility of the operator



- Use the device only as described in these Operating Instructions. The manufacturer assumes no responsibility for any other use.
- Maintenance work should be performed as prescribed in this Manual.
- Do not remove, add or change any components in or on the device unless such changes are officially allowed and specified by the manufacturer.
 - Otherwise the manufacturer's warranty becomes void.
 - Otherwise the device can become dangerous.
- Observe special local conditions.
 - Follow all local laws, regulations, and company policies applicable at the installation location.
- Retain documents. These Operating Instructions:
 - Must be kept available for reference.
 - Must be passed on to new owners.





Requirements on the maintenance personnel

- The technician must be familiar with the exhaust gas technology of the operator's plant (overpressure, toxic and hot flue gases) and be able to avoid hazards when working on gas ducts.
- The technician must be familiar with handling compressed gas cylinders (span gases).
- The technician must be able to avoid hazards caused by noxious span gases.
- The technician must be familiar with gas lines (PTFE lines) and their screw fittings (be able to ensure gas-tight connections).
- Only electricians are permitted to work on the electrical system or electrical subassemblies.

1.3 Symbols and document conventions

1.3.1 Warning symbols

Symbol	Significance
	Hazard (general)
	Hazard by voltage

Symbol	Significance
	Hazard by acidic substances
	Hazards by noxious substances
	Hazard by high temperature
	Hazard for the environment/nature/organic life

1.3.2 Warning levels / signal words

DANGER

Risk or hazardous situation which will result in severe personal injury or death.

WARNING

Risk or hazardous situation which could result in severe personal injury or death.

CAUTION

Hazard or unsafe practice which could result in less severe or minor injuries.



Notice

Hazard which could result in property damage.

Note

Hints.

1.3.3 Information symbols

Symbol	Significance
	Important technical information for this product
	Important information on electric or electronic functions

2 Safety information

2.1 Basic safety information

**WARNING**

Health risk through dangerous sample gas.
If dangerous sample gas is applied to the SFU:

- ▶ The operator is responsible for safe handling of sample gas.

**WARNING**

Risk of explosion in potentially explosive atmospheres.

- ▶ Do not operate the SFU in potentially explosive atmospheres.

**WARNING**

Hazards by explosive or combustible gases.

- ▶ Do not use the SFU for measuring explosive or combustible gases.

2.2 Warnings on the device

**CAUTION**

Warnings can be found on the device.

Overview of information on the device: [see "Warnings on the device", page 10.](#)

- ▶ Read and observe the information in these Operating Instructions for the respective warning.

2.3 Intended use

The gas sampling probe is used for extracting a partial stream of a gas mixture (usually flue gas) from a line, stack or similar and to retain particles that are contained in the gas stream.

2.4 Qualification of the operator

The SFU may only be maintained by persons properly instructed on the tasks assigned, possible risks and protective measures.

**WARNING**

Risk of injury due to lack of technical knowledge.

- ▶ Only perform work on the system if you are sure of being capable of performing this work correctly.
- ▶ You must be able to recognize potential risks and carry out safe actions.

Especially:

- ▶ For performing work on the electric system:
 - ▷ Let a skilled electrician carry out the work.
- ▶ For performing work on the sample gas path:
 - ▷ Be aware that the gas tightness of the sample gas path must be ensured.
 - ▷ To do this, you must be familiar with gas lines (PTFE) and handling the respective screw fittings.
 - ▷ Parts of sample gas sampling and sample gas lines are hot.

3 Product description

3.1 Product identification

Product name	SFU Variants: <ul style="list-style-type: none"> ■ Filter Unit SFU-BF NI ■ Filter Unit SFU-3V NI ■ Filter Unit SFU-BF NI GL The type designation can be found on the type plate.
Manufacturer	SICK AG Erwin-Sick-Str. 1 · 79183 Waldkirch · Germany
Type plate	The type plate is located on the installation plate on the underside of the gas sampling system.

Type plates and variants

Filter Unit SFU-BF NI	115/230V
PN 2041536	50-60 Hz
SN xxxxxxxx	450 VA
Gas sampling system for the typical use with the SICK measuring systems MCS100E HW, MCS300P HW, MCS100 FT <ul style="list-style-type: none"> • Filter 2 µm stainless steel • Backflush possible 	

Filter Unit SFU-BF NI GL	115/230V
PN 2058208	50-60 Hz
SN xxxxxxxx	450 VA
Gas sampling system for the typical use with the SICK measuring system MARSIC300 <ul style="list-style-type: none"> • Filter 0.1µm glass fiber • Backflush possible • Mechanically reinforced for higher vibrations (maritime certification) 	

Filter Unit SFU-3V NI	115/230V
PN 2056986	50-60 Hz
SN xxxxxxxx	450 VA
Gas sampling system for the typical use with the SICK measuring system MERCEM300Z <ul style="list-style-type: none"> • Filter 2 µm stainless steel 	



NOTICE

It is possible that your SFU has a different configuration to that described in this Manual.

- Refer to the System Documentation delivered with your SFU for the individual configuration of your system.

3.2 Warnings on the device

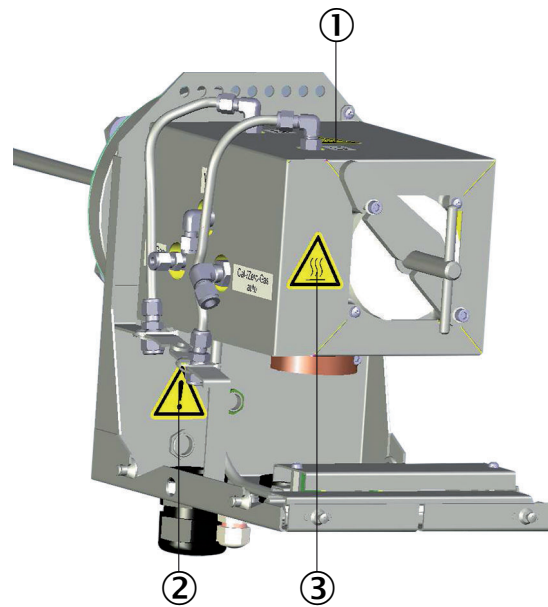

Figure 1: Location of the warning signs on the device

- ① Warning sign "Hot surface!"
- ② Warning sign "Caution!"
- ③ Warning sign "Hot surface!"

Further warning signs can be found on the weatherproof cover: "Voltage!" and "Hot surface!".



DANGER

Hazard by voltage.

- ▶ Only electricians may perform work on electrical components.
- ▶ Do not touch live components!
- ▶ Disconnect the device from the power supply before working on electrical components (e.g. by switching off the measuring system).



WARNING

Risk of burns on hot surfaces.

- ▶ Avoid contact with hot surfaces or wear protective clothing (e.g. protective gloves).
- ▶ Lay hot parts on fireproof supports only.



WARNING

General risk of injury due to improper handling.

- ▶ Only perform work on this device if you have adequate expert knowledge for the respective work.
- ▶ Observe the Operating Instructions and the warnings stated therein.

3.3 Product description

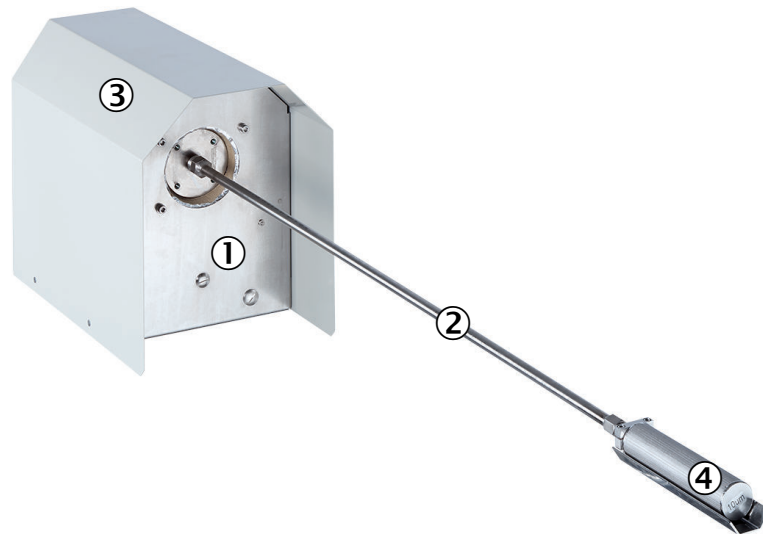

Figure 2: Configuration example of a SFU

- ① Gas sampling filter
- ② Probe tube (unheated)
- ③ Weatherproof cover
- ④ Coarse filter (optional)

The gas sampling system consists of gas sampling filter, probe tube, weatherproof cover and optional coarse filter.

Application area

The gas sampling system SFU is used for flue gas extraction and filtering for analysis in a measuring system.

The flue gas is taken via a probe tube and fed to a measuring system after filtration.

As an option, the probe tube can be heated.

As an option, the probe tube contains a coarse filter at the probe tip.

Measuring system

The gas sampling system is operated on a SICK measuring system. Thus, only this operating mode is described in this Manual.

Applications with customer-owned peripheral devices are not planned.

3.4 Design

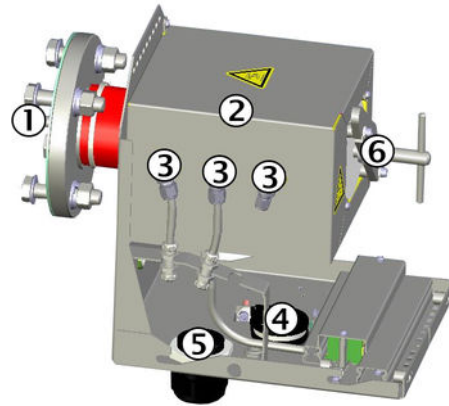

Figure 3: SFU-BF NI and SFU-BF NI GL

- ① Probe tube
- ② Filter housing
- ③ 3 pneumatic lines (backflush, activation of main valve, zero gas)
- ④ Output sample gas line
- ⑤ Input tube bundle cable (electrical and pneumatic lines)
- ⑥ Fine filter cartridge with rotary handle

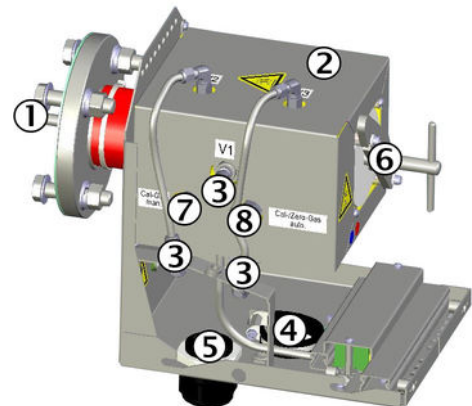

Figure 4: SFU-3V NI

- ① Probe tube
- ② Filter housing
- ③ 3 pneumatic lines for activation
- ④ Output sample gas line
- ⑤ Input tube bundle cable (electrical and pneumatic lines)
- ⑥ Fine filter cartridge with rotary handle
- ⑦ Manual activation of calibration gas
- ⑧ Automatic activation of calibration gas

The gas sampling system consists of the following subassemblies:

- Probe tube:
 - Heated probe tube
 - Unheated probe tube
 - Optional: Coarse filter in the probe tip
- SFU consisting of:
 - Heated filter housing with filter
 - Weatherproof cover

The electrically heated filter housing is made of coated aluminum and is isolated by an aluminum housing lined with polyimide.

The weatherproof cover consists of powder coated steel plate.

Thermostatic control

The gas sampling system is thermostatic-controlled.

- Heating control with Pt100 sensor and external heating control
- Limit value monitoring in the controller of the measuring system

3.4.1 Probe tube

The length of the probe tube depends on the conditions at the sampling point.

The probe tube is available as heated and unheated version.

The probe tube can be equipped with a coarse filter (2µm or 10µm). The coarse filter is screwed to the probe tip.

See the System Documentation delivered for the type and length of the probe tube.

**NOTE**

The heated probe tube is delivered pre-assembled.

Further assembly steps are necessary for the unheated probe tube, see ["Installing the probe tube on the gas sampling filter"](#), page 23.

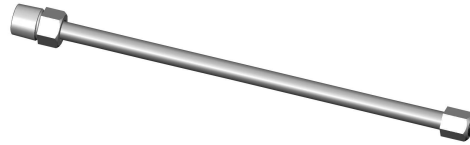

Figure 5: Unheated probe tube

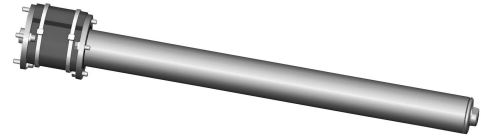

Figure 6: Heated probe tube



Figure 7: Coarse filter

4 Installation and start-up

4.1 Important information



WARNING

Risk of injury through lifting.

The instrument has a weight of approx. 20 kg.

- ▶ Use proper lifting techniques or auxiliary equipment to lift or move the instrument.
- ▶ Do not lift the device by holding it at the weatherproof cover, always hold it at the device base.
- ▶ If necessary, work together with another person.



WARNING

Health risk through dangerous sample gas.

If dangerous sample gas is applied to the SFU: The operator is responsible for safe handling of sample gas.

- ▶ In addition to these Operating Instructions, observe all local laws, technical rules, and company-internal instructions valid at the site where the SFU is installed.
- ▶ Operate the SFU only in rooms with adequate installation OR install suitable gas monitoring equipment.
- ▶ Channel sample gas off safely.



WARNING

Hazard due to sample gas pressure.

The stacks can have underpressure or overpressure.

- ▶ Observe information from the plant operator.



WARNING

Risk of burns on hot surfaces.

Filter housing, flanges and sample gas lines can be hot.

- ▶ Before starting any work on the device parts, allow the surfaces to cool down to body temperature or wear appropriate protective gloves.



WARNING

Danger to life by electric voltage

- ▶ Only allow an authorized electrician to work on the electric system

The assembly of the gas sampling system contains the following work steps:

Step	Work step	Remarks	Page
1	Install the welding neck flange	Has to be performed by the operator beforehand	page 16
2	Connect the sample gas line		page 18
3	Connect the hoses for valves		page 19
4	Connect the electrical connections		page 21
5	Attach the probe tube	Only necessary for unheated probe tubes	page 23

Step	Work step	Remarks	Page
6	Attach the SFU to the welding neck flange	Observe preheating period	page 24

4.2 Weatherproof cover



Figure 8: Weatherproof cover SFU-BF NI and SFU-3V NI

- ① Screw closure
- ② Pilot pin and guide slot (covered)



Figure 9: Weatherproof cover SFU-BF NI and SFU-BF NI GL

- ① Screw closure



DANGER

Hazard by voltage.

Live parts are accessible after the weatherproof cover has been opened.

- ▶ Disconnect the gas sampling system from the power supply before opening the weatherproof cover (for example by switching off the measuring system).



CAUTION

Risk of burns on hot surfaces.

You can perform work on hot filters (approx. 185 °C).

- ▶ Wear suitable gloves as required.

Removing the weatherproof cover

- 1 Unlock the screw closures.
- 2 Pull the weatherproof cover away from the probe tube and lift.

Fitting the weatherproof cover

- 1 Fit the weatherproof cover in the direction of the probe tube.
- 2 Lock the screw closures.

4.3 Preparing the tube bundle cable



Tube bundle cable (system-specific example) with:

- Power supply
- Grounding conductor
- Signal lines
- Tube, gray: Zero gas/span gas
- 2 x tubes, black/blue: Main valve and backflush

The tube bundle cable (option) connects the SFU to the measuring system.

Preparation of the tube bundle cable



NOTE

Leave a sufficient length for pulling the gas sampling system out of the stack (approx. 2 m).

- 1 Strip the tube bundle cable and shorten the hoses and lines to the required length.
Cut the hoses in a right-angle to avoid damaging the lines and hose lines.
- 2 Shorten the flexible wires to the required length and press the crimp lead end sleeves onto the ends of the flexible wires.

4.4 Mounting

4.4.1 Installing the welding neck flange



WARNING

Risk of burns by hot flanges.

The flanges can reach high temperatures.

- ▶ Before starting any work on the flanges, allow the flanges to cool down to body temperature or wear appropriate protective gloves.
-



DANGER

Health risk through hot or toxic gases/dusts in the measuring channel

The measuring channel can contain hot or toxic gases or dust which can escape when opening the duct-side flange. Even if the measuring channel is out of operation during the installation, escaping gases can lead to severe damage to health.

- ▶ Always put the measuring channel out of operation during installation.
- ▶ If required, purge the measuring channel with ambient air before starting installation work.
- ▶ Always wear suitable or company-specified protective clothing during installation work.

The operator is responsible for installing the welding neck flange.

See the System Documentation delivered for the specification of the flange connection.

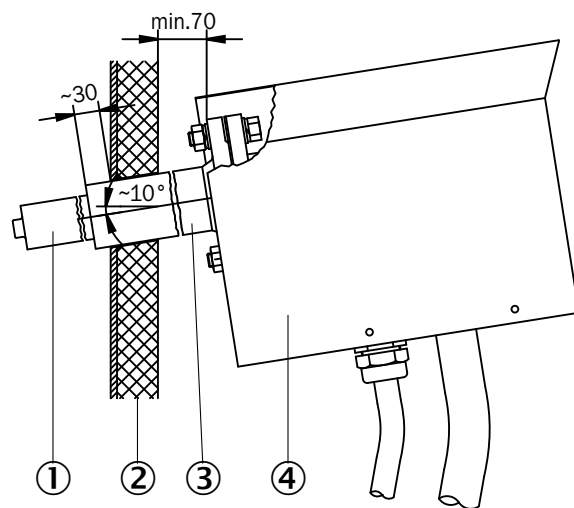

Figure 10: Installation requirements for welding neck flange

- ① Probe tube
- ② Stack
- ③ Welding neck flange
- ④ Gas sampling filter

- ▶ Attach the flange with a tilt of approx. 10°.

4.4.2 Connection of sample gas line

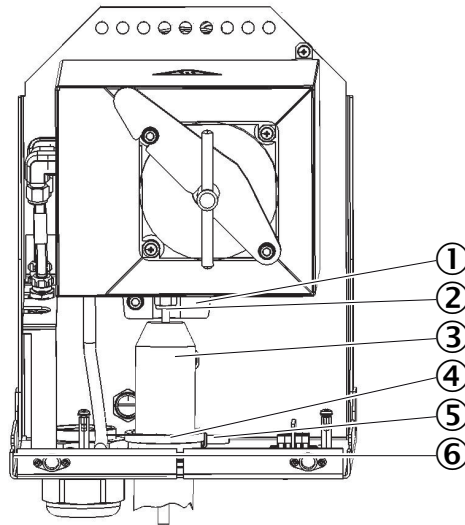

Figure 11: Sample gas connection SFU-BF NI and SFU-BF NI GL

- ① Insulating shell
- ② Clamping ring screw connection
- ③ Sample gas line
- ④ Hose clamp
- ⑤ Screw for hose clamp
- ⑥ Opening for screwdriver

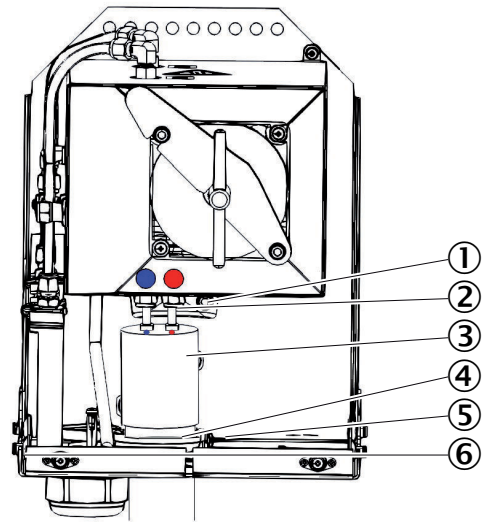

Figure 12: Sample gas connection SFU-3V NI

- ① Clamping ring screw connection
- ② Insulating shell
- ③ Sample gas line
- ④ Hose clamp
- ⑤ Screw for hose clamp
- ⑥ Opening for screwdriver



NOTE

If you lay the heated sample gas line before installing the gas sampling system:
Observe the installation of the sample gas line:

- ▶ Start laying at the measuring system:
 - The end **with** electrical connection is connected to the measuring system.
 - The end **without** electrical connection is connected to the gas sampling system.

Roll-up excess length on the gas sampling system.
Leave enough length for pulling out the gas sampling system (approx. 2 m).
- ▶ Protect the line from damage (chafing through vibration, mechanical load).
- ▶ Observe minimum bend radius of 300 mm.

1. Remove the weatherproof cover (see "Weatherproof cover", page 15).
2. Unscrew the insulation half-shell.
3. Lead the sample gas line through the bottom of the installation plate and the hose clamp.
4. Screw the sample gas line tight on the clamping ring screw connection.
For SFU-3V NI: The tube connections are color coded. Do not mix up the connections.
 - For first screwing (clamping ring still loose): 1¼ turn to "hand-tight".
 - For further screwing: (clamping ring tight) ¼ turn to "hand-tight".
5. Fasten the sample gas line using a hose clamp. The screw head can be reached via an opening in the chamfer of the installation plate.
6. Screw the insulation half-shell back on again.
7. Check the hose connections for leaks:
The leak tightness check is performed via the connected measuring system: See the Operating Instructions of the measuring system.

4.4.3 Connection of the pneumatic lines



NOTICE

Risk of damaging the measuring system!

- Ensure correct assignment of the pneumatic connections!
- Ensure leak tightness of the system!

Connection for SFU-BF NI and SFU-BF NI GL

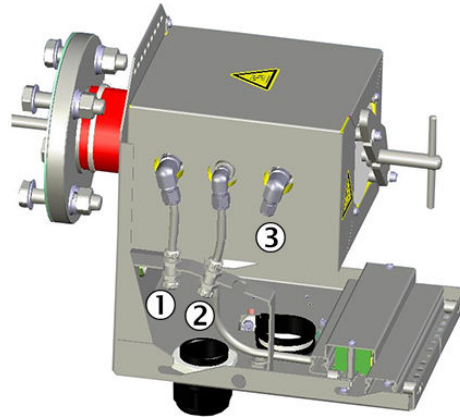

Figure 13: Connection of pneumatic lines
SFU-BF NI and SFU-BF NI GL

- ① Backflush
- ② Main valve
- ③ Zero gas

1. Push the cap nut onto the tube bundle cable.
2. Lead the tube bundle cable through the installation plate and the cable gland.
3. Connect the 3 hoses with the 3 hose fittings on the filter housing and ensure correct layout.
4. Push the hoses flush over the hose connections of the hose fitting.
5. Hose for the zero gas: Use clamping ring screw connection with support sleeve.
6. Tighten the cap nut by hand.
7. Screw the cable gland tight.

Connection for SFU-3V NI

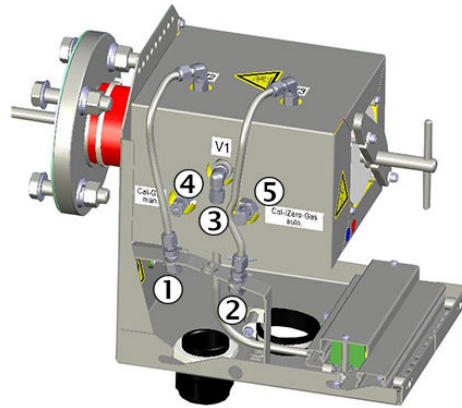

Figure 14: Connection of pneumatic lines SFU-3V NI

- ① Tecalan tube #1 to V2
- ② Tecalan tube #2 to V3
- ③ PTFE tube 6 mm (NpT1/4") to V1
- ④ Input for manual span gas feed, 6 mm (NpT1/8")
- ⑤ Input for automatic span gas feed, 8 mm (NpT1/4")



NOTE

If you lay the heated sample gas line before installing the gas sampling system - observe the installation of the sample gas line:

- ▶ Leave enough length for pulling the gas sampling system out.

1. Push the cap nut onto the hose.
2. Lead the tube bundle cable through the installation plate and the cable gland.
3. Connect the 3 tubes:
 - Tecalan tube #1 to V2
 - Tecalan tube #2 to V3
 - PTFE tube 6 mm to V1
4. Push the hoses flush over the hose connections of the hose fitting.
5. Tighten the cap nut by hand.
6. Screw the cable gland tight.

4.4.3.1 Adapter for inch thread (option)

If you want to connect pneumatic lines with inch thread: There is an adapter set with 4 clamping ring screw fittings.

Part No. "Adapter set inch thread": 2083838

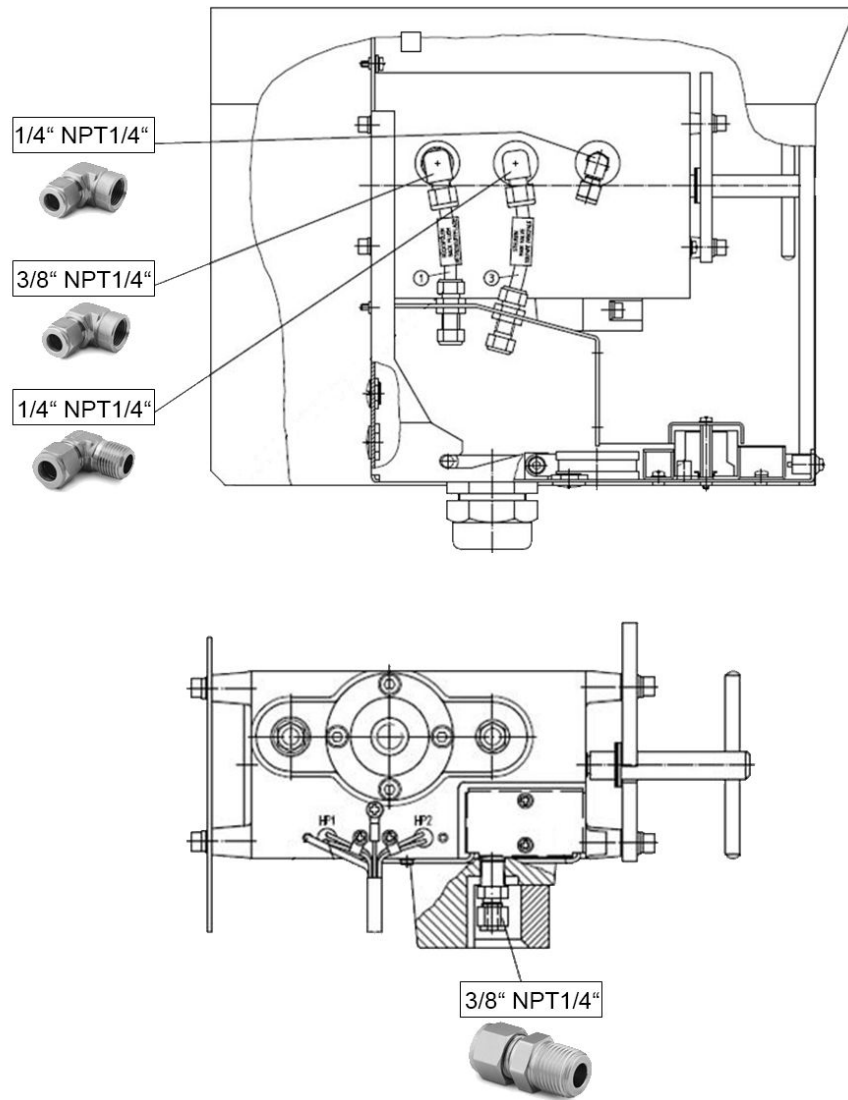

Installation

1. Wrap the thread with 2 - 2.5 layers of Teflon tape
2. Tighten the adapter with an open-end wrench until a distinct increase in strength is felt
Then tighten it approx. 1/8 - 1/4 turn

4.5 Electrical installation



WARNING

Danger to life by electric voltage

- ▶ Only allow an authorized electrician to work on the electric system



WARNING

Risk of short-circuit due to condensate.

- ▶ Allow the electronics to acclimatize sufficiently before connecting.

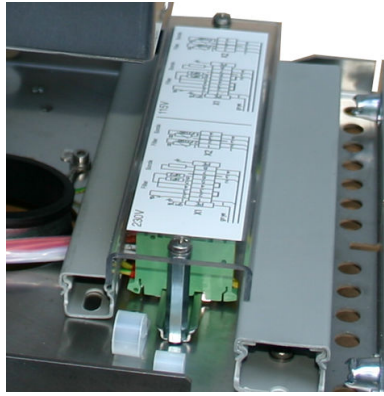

Figure 15: Terminal diagram for electrical connections

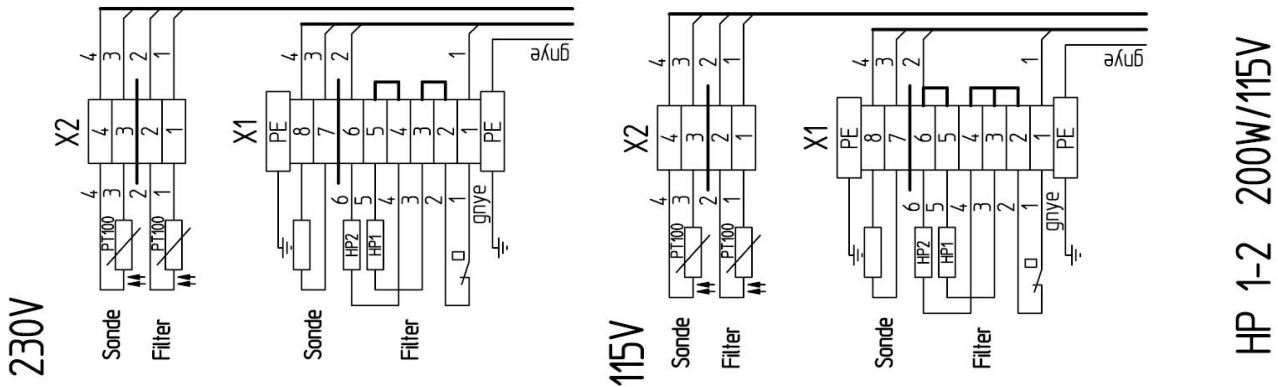

Figure 16: Terminal diagram for 230 V and 115 V

The electrical connection of the gas sampling filter is made via the connection terminals on the installation plate.

Observe the terminal diagram on the protective cover.

The temperature sensors and the heating cartridges are wired ex factory.

- ▶ Remove the protective cover.
- ▶ Perform electrical connections.

4.6 Installing the probe tube on the gas sampling filter

Installing the unheated probe tube

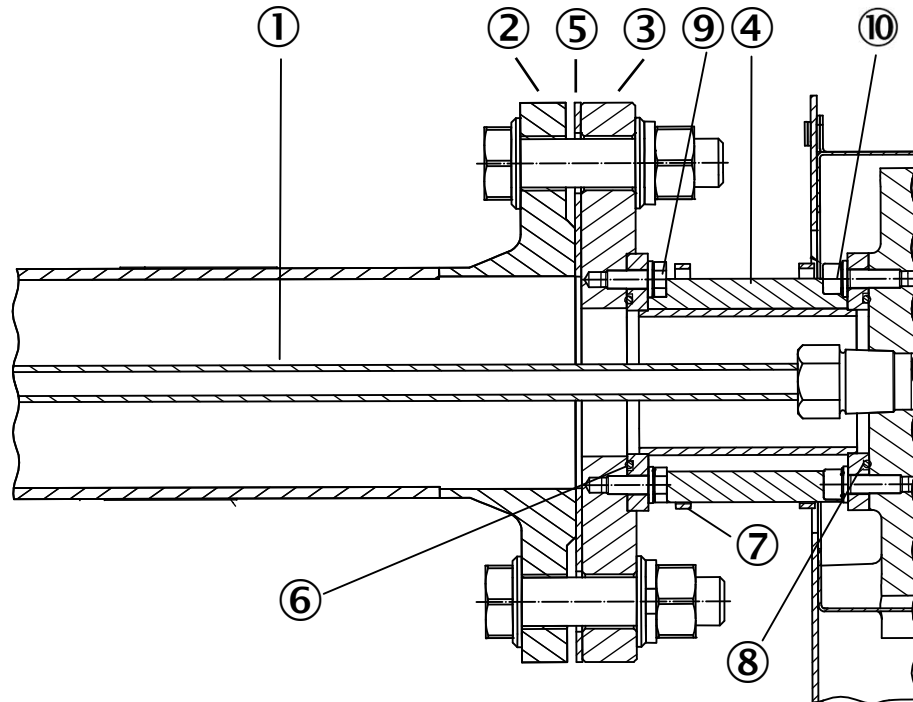

Figure 17: Detailed view of the unheated probe tube

- ① Probe tube (unheated)
- ② Welding neck flange
- ③ Fine filter flange
- ④ Transition flange
- ⑤ Seal
- ⑥ O-ring
- ⑦ Cable clips
- ⑧ O-ring
- ⑨ Hexagon screw M6x10
- ⑩ Cylinder screw M6x20

1. Lay the insulation hose (red) around the transition flange and secure with 2 cable clips.
2. Lay the O-ring into the respective groove of the transition flange and tighten it to the gas sampling system using the washers, lock washers and M6 cylinder screws.
3. Lay the O-ring into the free groove of the transition flange and tighten the fine filter flange to the transition flange using the washers, lock washers and M6 hexagon screws.
4. Wrap the probe tube connection (1/2" NPT outer thread) with Teflon sealing tape and screw into the respective screw fitting of the gas sampling system.

Installing the heated probe tube

The gas sampling system with heated probe tube is delivered pre-assembled.

Installing the coarse filter

The coarse filter can be screwed to the heated and unheated probe tube.

- 1 Wrap the thread with Teflon tape.
- 2 Screw the coarse filter onto the probe tip and tighten it hand-tight with a wrench.

4.7 Installing the SFU on the welding neck flange



NOTICE

Risk of contamination of the gas sampling system.

Do not install a cold gas sampling system on the stack.

- ▶ Allow the gas sampling system to warm up before installing it on the welding neck flange.
- ▶ Warm-up time: Approx. 1.5 h at 25 °C ambient temperature.

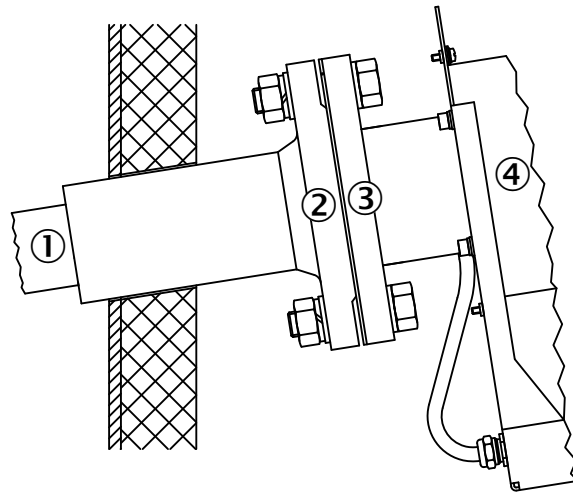

Figure 18: Installation of probe tube on welding neck flange

- ① Probe tube
- ② Welding neck flange
- ③ Fine filter flange
- ④ Filter housing



WARNING

Risk of burns on hot surfaces.

The probe tube and the gas sampling system are hot during operation.

- ▶ Wear suitable protective clothes, for example, heat-resistant gloves.

1. Push the seal over the probe tube.
2. Push the gas sampling system with probe tube into the welding neck flange. The hose outputs of the gas sampling system have to point downwards.
3. Screw the fine filter flange of the gas sampling system to the welding neck flange.
4. Fit the weatherproof cover: [see "Weatherproof cover", page 15.](#)

5 Maintenance

5.1 Important Information



WARNING

Risk of injury through lifting.

The instrument has a weight of approx. 20 kg.

- ▶ Use proper lifting techniques or auxiliary equipment to lift or move the instrument.
- ▶ Do not lift the device by holding it at the weatherproof cover, always hold it at the device base.
- ▶ If necessary, work together with another person.



WARNING

Health risk through dangerous sample gas.

If dangerous sample gas is applied to the SFU: The operator is responsible for safe handling of sample gas.

- ▶ In addition to these Operating Instructions, observe all local laws, technical rules, and company-internal instructions valid at the site where the SFU is installed.
- ▶ Operate the SFU only in rooms with adequate installation OR install suitable gas monitoring equipment.
- ▶ Channel sample gas off safely.



WARNING

Hazard due to sample gas pressure.

The stacks can have underpressure or overpressure.

- ▶ Observe information from the plant operator.



WARNING

Risk of burns on hot surfaces.

Filter housing, flanges and sample gas lines can be hot.

- ▶ Before starting any work on the device parts, allow the surfaces to cool down to body temperature or wear appropriate protective gloves.



WARNING

Danger to life by electric voltage

- ▶ Only allow an authorized electrician to work on the electric system



5.2 Maintenance plan

No.	Maintenance work	Reference	Interval
W1	Replace the Sinter fine filter cartridge and seals	see "Replacing the Sinter fine filter", page 26	3M ¹
W2	Replace glass fiber fine filter cartridge and seals	see "Replacing the glass fiber fine filter", page 29	3M ¹
W3	Check gas connections	see "Checking for correct operation", page 35	3M ¹

¹ 3M = every 3 months

No.	Conversion	Reference	Interval
U1	Change from Sinter to glass fiber filter	see "Retrofitting the fine filter", page 32	-

5.3 Spare parts

Required spare parts for W1 and W2	Part number	Quantity required	Picture
Service kit (contains: 1*2 µm fine filter cartridge, 2*flat seals, 1*O-ring)	2039002	1	
Service kit (contains 1*0.1µm glass fiber filter cartridge, 1*flat seal, 1*O-ring)	2043616	1	

Required spare parts for U1	Part number	Quantity required	Picture
Glass fiber filter with holder (contains 1*0.1µm fine filter cartridge, adapter, 1*flat seal, 1*O-ring)	2024972	1	



NOTE

Further spare parts can be found in the individual System Description provided with the gas sampling system.

5.4 Replacing the Sinter fine filter

You can perform the work while the filter is hot.

In this case, pay special attention to the warning about hot surfaces.

The filter can have an internal temperature of 185 °C.



WARNING

Risk of burns on hot surfaces.

The filter can reach high temperatures during operation.

- ▶ Wear suitable gloves as required.
- ▶ Provide a heat-resistant support as required.



WARNING

Risk of injury by toxic substances.

Depending on the sample gas composition, it is possible that the fine filter cartridge contains toxic substances.

- ▶ Observe the relevant safety regulations.
- ▶ Dispose of fine filter cartridges in an environmentally compatible manner.

Procedure

1. Switch off the fuse of the gas sampling system in the measuring system.
For position of the fuse, refer to the System Documentation provided with the measuring system.
2. Remove the weatherproof cover: see "Weatherproof cover", page 15.
3. Check all gas connections:
 - o Optical condition
 - o Tight seat
 - o Leak tightness:
The leak tightness check is performed via the connected measuring system:
See the Operating Instructions of the measuring system.

Replacing the Sinter fine filter cartridge

1. Loosen the rotary handle counterclockwise.

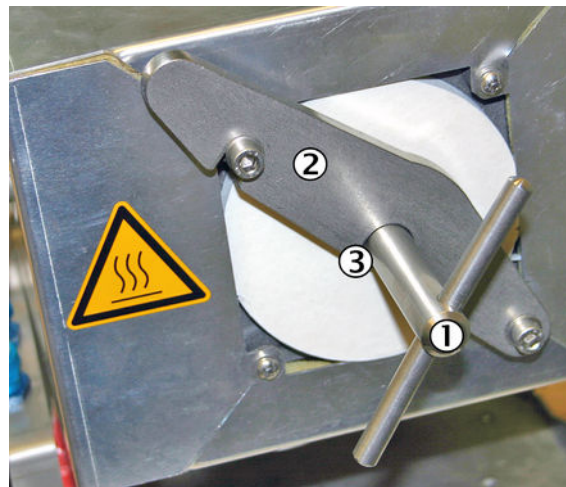

- ① Rotary handle
- ② Mounting bracket
- ③ Pressure disk (covered)

2. Swivel the mounting bracket to the right



WARNING

Risk of burns on hot surfaces.

The inner parts of the gas sampling filter can be especially hot (185 °C).

- ▶ Wear suitable gloves as required.
- ▶ Provide a heat-resistant support as required.



CAUTION

Heavy.

- ▶ Do not drop the filter cover!

3. Pull the filter cover out using the rotary handle.
4. If the filter cover is hot: Place the filter cover on a heat-resistant mat.

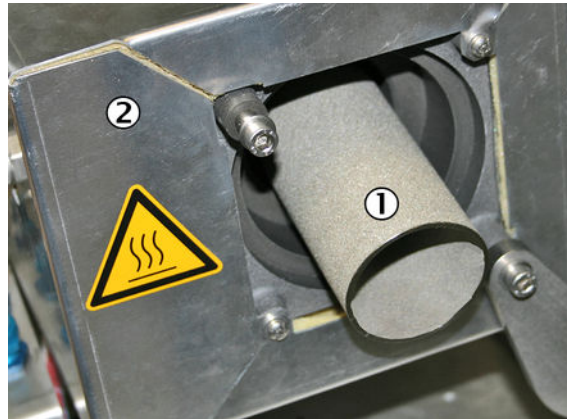

- ① Sinter fine filter
- ② Filter housing

5. Remove the fine filter cartridge.

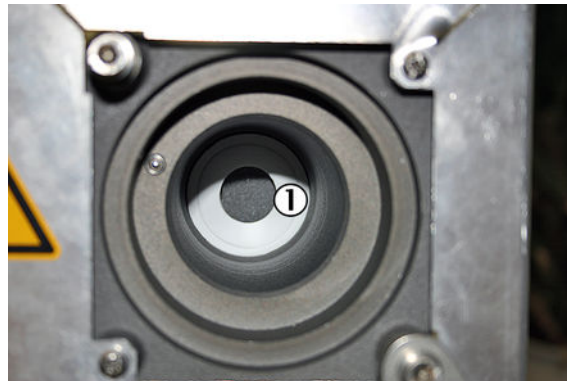

- ① Bottom flat seal

6. Pull out the bottom flat seal with a hook.

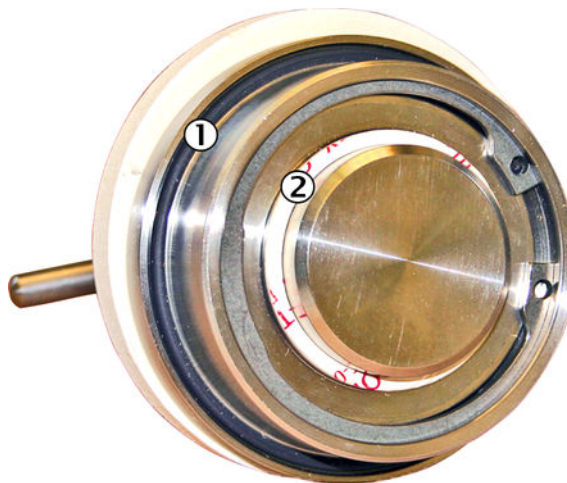

- ① O-ring
- ② Flat seal

7. Insert new bottom flat seal.
8. Replace O-ring and flat seal of the filter cover.
9. Insert new or cleaned Sinter fine filter cartridge.
If one side of the fine filter cartridge has a groove: The groove must point in the direction of the filter cover.
10. Fit the filter cover.

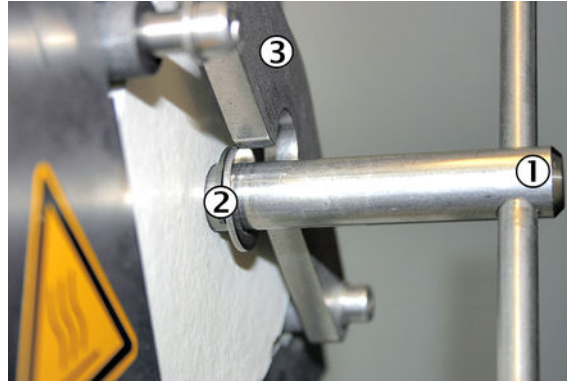

- ① Rotary handle
- ② Pressure disk
- ③ Mounting bracket

11. Swing back the mounting bracket. Make sure that the pressure disk is behind the mounting bracket.
12. Tighten the rotary handle clockwise.
13. Fit the weatherproof cover again: see "[Weatherproof cover](#)", page 15.

5.5 Replacing the glass fiber fine filter

You can perform the work while the filter is hot.

In this case, pay special attention to the warning about hot surfaces.

The filter can have an internal temperature of 185 °C.



WARNING

Risk of burns on hot surfaces.

The filter can reach high temperatures during operation.

- ▶ Wear suitable gloves as required.
- ▶ Provide a heat-resistant support as required.



WARNING

Hazard by toxic substances.

Depending on the sample gas composition, it is possible that the fine filter cartridge contains toxic substances.

- ▶ Observe the relevant safety regulations.
- ▶ Dispose of fine filter cartridges in an environmentally compatible manner.

Replacing fine filter cartridge

1. Loosen the rotary handle counterclockwise.

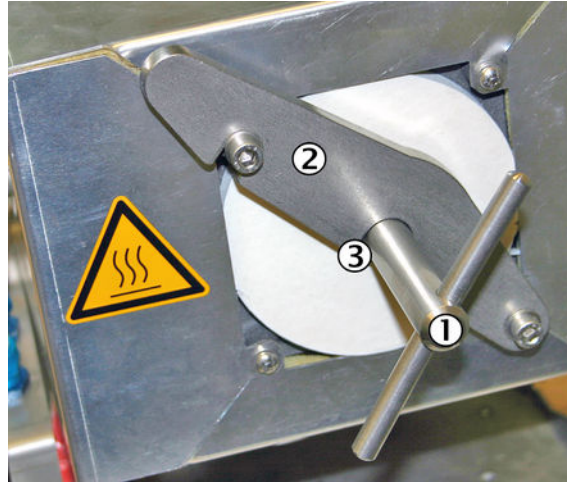

- ① Rotary handle
- ② Mounting bracket
- ③ Pressure disk (covered)

2. Swing the mounting bracket to the right.



WARNING

Risk of burns on hot surfaces.

The filter can reach high temperatures during operation.

- ▶ Wear suitable gloves as required.
- ▶ Provide a heat-resistant support as required.



CAUTION

Heavy.

- ▶ Do not drop the filter cover!

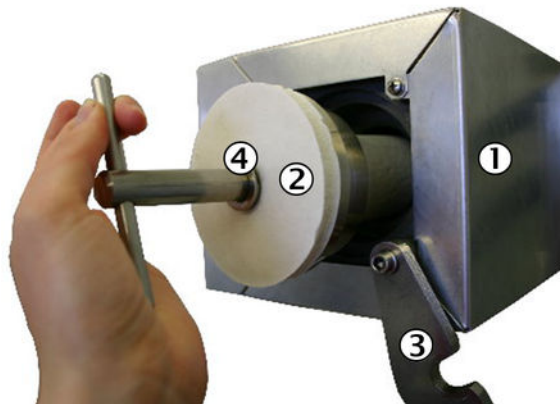

- ① Filter housing
- ② Filter cover
- ③ Mounting bracket
- ④ Pressure disk

- 3. Pull the filter cover with glass fiber fine filter cartridge out using the rotary handle.
- 4. If the filter cover is hot: Place the filter cover on a heat-resistant mat.

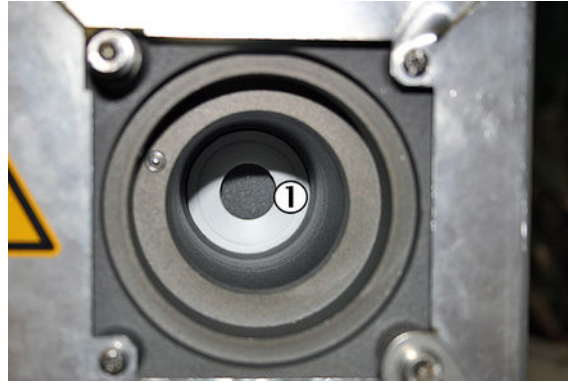

① Bottom flat seal

5. Pull out the bottom flat seal with a hook.
6. Loosen the glass fiber fine filter cartridge from the filter handle by opening the spiral thread.

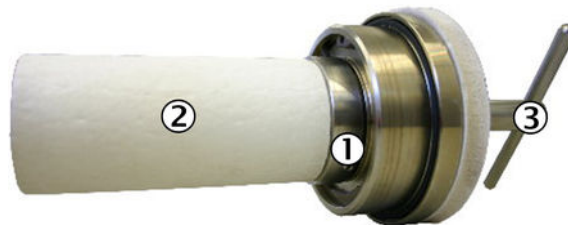

① O-ring
 ② Glass fiber filter
 ③ Rotary handle

7. Insert new bottom flat seal.
8. Renew the O-ring in the filter cover.
9. Fit new or cleaned glass fiber fine filter cartridge on the filter cover and tighten the spiral thread.
 If one side of the fine filter cartridge has a groove: The groove must point in the direction of the filter cover.
10. Replace the filter cover.

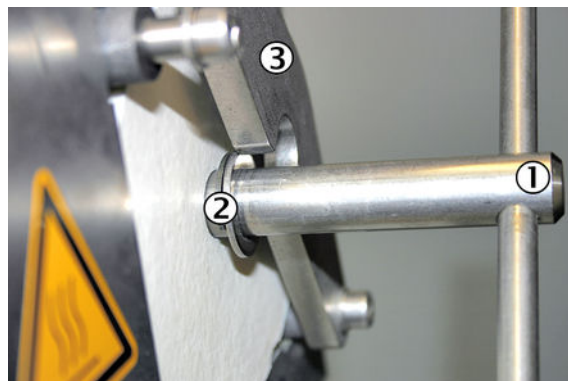

① Rotary handle
 ② Pressure disk
 ③ Mounting bracket

11. Swing back the mounting bracket. Make sure that the pressure disk is behind the mounting bracket.
12. Tighten the rotary handle clockwise.
13. Fit the weatherproof cover again: see "[Weatherproof cover](#)", page 15.

5.6 Retrofitting the fine filter

You can perform the work while the filter is hot.

In this case, pay special attention to the warning about hot surfaces.

The filter can have an internal temperature of 185 °C.



WARNING

Risk of burns on hot surfaces.

The filter can reach high temperatures during operation.

- ▶ Wear suitable gloves as required.
 - ▶ Provide a heat-resistant support as required.
-



WARNING

Hazard by toxic substances.

Depending on the sample gas composition, it is possible that the fine filter cartridge contains toxic substances.

- ▶ Observe the relevant safety regulations.
 - ▶ Dispose of fine filter cartridges in an environmentally compatible manner.
-

Procedure

1. Switch off the fuse of the gas sampling system in the measuring system.
Refer to the System Documentation provided with the measuring system for position of the fuse.
2. Remove the weatherproof cover: [see "Weatherproof cover", page 15](#).
3. Check all gas connections:
 - Optical condition
 - Tight seat
 - Leak tightness:
The leak tightness check is performed via the connected measuring system:
See the Operating Instructions of the measuring system.

Retrofitting the Sinter filter to glass fiber filter

1. Loosen the rotary handle counterclockwise.

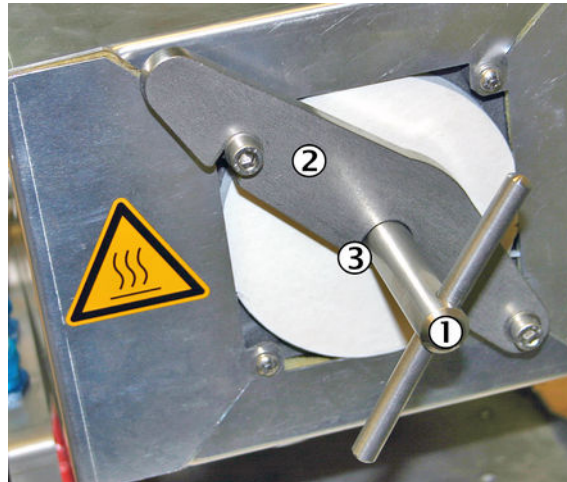

- ① Rotary handle
- ② Mounting bracket
- ③ Pressure disk (covered)

2. Swing the mounting bracket to the right.



WARNING

Risk of burns on hot surfaces.

The filter can reach high temperatures during operation.

- ▶ Wear suitable gloves as required.
- ▶ Provide a heat-resistant support as required.



CAUTION

Heavy.

- ▶ Do not drop the filter cover!

3. Pull the filter cover out using the rotary handle.

4. If the filter cover is hot: Place the filter cover on a heat-resistant mat.

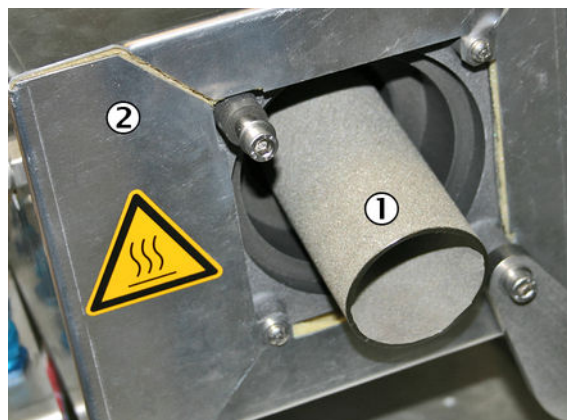

- ① Sinter fine filter
- ② Filter housing

5. Remove the fine filter cartridge.

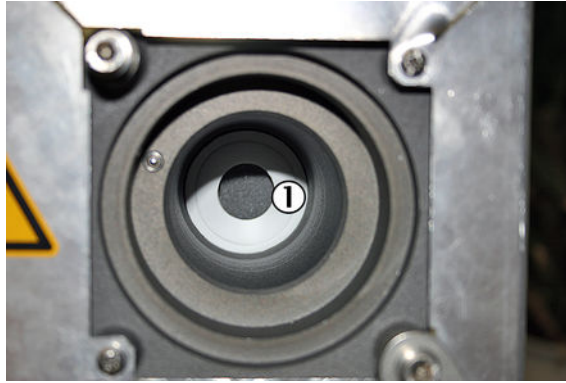

① Bottom flat seal

6. Pull out the bottom flat seal with a hook.

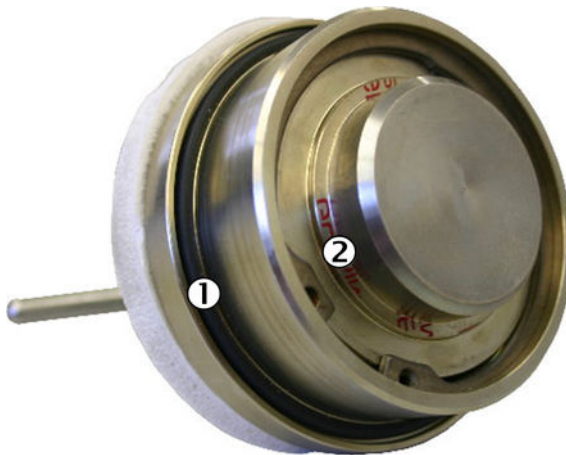

① O-ring
② Position of flat seal

7. Insert new bottom flat seal.
8. Replace O-ring and flat seal of the filter cover.

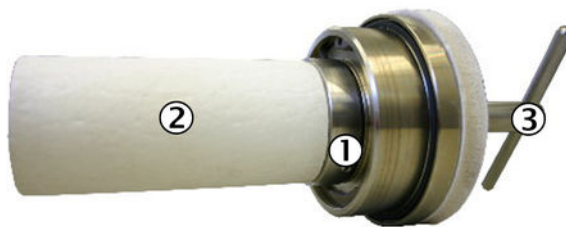

① Spiral thread
② Glass fiber filter
③ Rotary handle

9. Fit the glass fiber fine filter cartridge onto the filter cover and tighten with a spiral thread.
If one side of the fine filter cartridge has a groove: The groove must point in the direction of the filter cover.
10. Replace the filter cover.

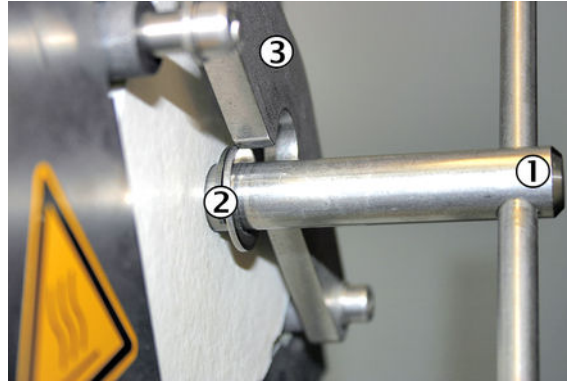

- ① Rotary handle
- ② Pressure disk
- ③ Mounting bracket

11. Swing back the mounting bracket. Make sure that the pressure disk is behind the mounting bracket.
12. Tighten the rotary handle clockwise.
13. Fit the weatherproof cover again: see "[Weatherproof cover](#)", page 15.

5.7 Checking for correct operation

- Check all fastening screws of the housing for tight seat.
- Check the sample gas line for damage.
- Check all hose fittings for tight seat.
- Check gas sampling system for cleanness, dryness and freedom from corrosion.
- Check all electric connections for freedom from corrosion and tight seat.
- Check grounding conductors are free from corrosion.
- Perform a leak tightness check:
The leak tightness check is performed via the connected measuring system: See the Operating Instructions of the measuring system.

6 Troubleshooting

6.1 Troubleshooting

Fault	Possible cause	Correction
Gas throughput decreases	Coarse filter contaminated	Clean or replace
	Fine filter contaminated	
Heating failed	Heating cartridge or temperature sensor defective	Replace seal
	Defective seal	If necessary, replace seal or defective component
Contaminated or corroded gas paths	Defective or missing coarse filter	Replace
Leaky non-return valves	Contaminated instrument air	Replace Check the purity of the instrument air
Leaky main valve	Valve seating contaminated or damaged	Replace the valve cone Replace the filter housing
	Metal bellow leaky	Replace the metal bellow

7 Disposal

The device can easily be disassembled into its components which can then be sent to the respective raw material recycling facilities.



WARNING

Filters and lines with sample gas contact can contain toxic substances.

Observe the relevant safety regulations.

- ▶ Depending on their components, filters and lines with sample gas contact must be disposed of according to the legal regulations. If required, they must be treated as hazardous waste.
-

8 Technical data

8.1 Compliances and Standards

Compliance

The technical design of the devices SFU-BF NI, SFU-BF NI GL and SFU-3V NI correspond to the following guidelines and standards:

- EC Directive: LVD (Low Voltage Directive)
EN 61010-1: Safety requirements for electrical equipment for measurement, control and laboratory use
- EC Directive: EMC (Electromagnetic Compatibility)
EN 61326: Electrical equipment for measurement, control and laboratory use, EMC requirements

Further standards: See Declaration of Conformity provided with the device

Additional standards for SFU-BF NI GL

- MARPOL Annex VI and NTC 2008 - MEPC.177(58)
- Guidelines for exhaust gas cleaning systems - MEPC.184(59)
- DNV GL Rules for Classification and Construction, Part VI Additional Rules and Guidelines Chapter 7, Guidelines for the Performance of Type Approvals, Test Requirements for Electrical / Electronic Equipment and Systems (2012)

Electrical compliance

- CE
- DNV GL Rules

8.2 Dimensions

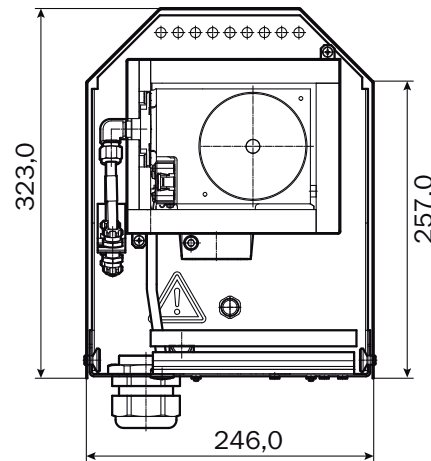

Figure 19: SFU-BF NI and SFU-BF NI GL

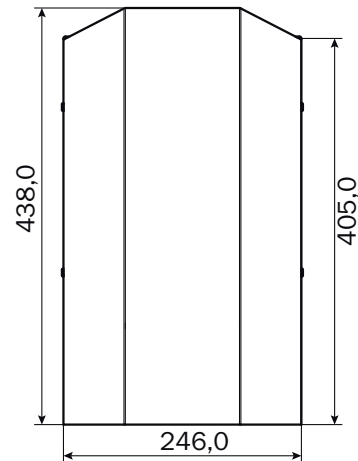

Figure 20: SFU-BF NI and SFU-BF NI GL

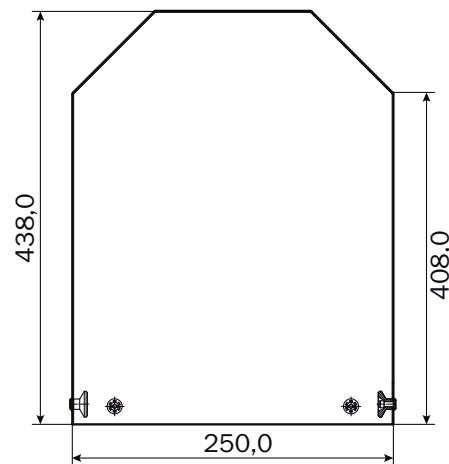

Figure 21: SFU-3V NI

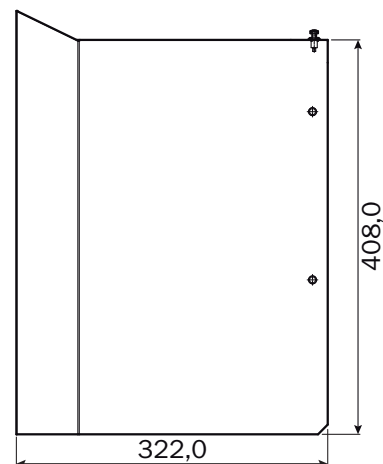

Figure 22: SFU-3V NI

8.3 Operating data

Ambient conditions	SFU-BF NI	SFU-BF NI GL	SFU-3V NI
Ambient temperature	+5 ... +45 °C (+40 ... 110 °F)		
Storage temperature	-20 ... +60 °C (-5 ... 140 °F)		
Relative humidity	Max. 80%		
Degree of protection	IP23	IP23	IP23

Installation	SFU-BF NI	SFU-BF NI GL	SFU-3V NI
Tubing SFU-BF NI and SFU-BF NI GL <ul style="list-style-type: none"> Main valve Zero gas Backflush Sample gas line 	. Dimensions: <ul style="list-style-type: none"> 8 mm 6 mm 8 mm 6 mm 	. Dimensions: <ul style="list-style-type: none"> 8 mm 6 mm 8 mm 6 mm 	---
Tubing SFU20-Hg <ul style="list-style-type: none"> Control valves Span gas manual Span gas automatic Sample gas line 	---	---	Dimensions: <ul style="list-style-type: none"> 6 mm 6 mm NpT1/4" 6 mm
Compressed air <ul style="list-style-type: none"> Main valve Zero gas Backflush 	Pressure: <ul style="list-style-type: none"> 5 - 6 bar (500 - 600 kPascal) 2.5 - 3 bar (250 - 300 kPascal) 5 - 6 bar (500 - 600 kPascal) 		---
Flange NW = Rated width ND = Rated pressure	NW 50, ND 16 NW 65, ND 6 or 16 NW 80, ND 16 NW 100, ND 16 ANSI 4"	NW 65, ND 6	NW 50, ND 16 NW 65, ND 6 or 16 NW 80, ND 16 ANSI 4"
Fitting position	Horizontally with an inclination of approx. 10° (see "Installing the welding neck flange", page 16)		

Power consumption	SFU-BF NI	SFU-BF NI GL	SFU-3V NI
Gas sampling filter	Max. 115/230 V, 50-60 Hz , 450 VA		
Probe tube, heated	Max. 115/230 V, 50-60 Hz , 450 VA (0.8, 1, 1.5, 2 m)		

Device characteristics	SFU-BF NI	SFU-BF NI GL	SFU-3V NI
Materials <ul style="list-style-type: none"> Probe tube Enclosure Parts attached to enclosure Screw fittings Seals 	Materials <ul style="list-style-type: none"> Application-dependent Aluminum, coated High grade steel 1.4541 resp. 1.4301 High grade steel ANSI 316 (V4A) PTFE/FKM/FFKM 		
Weight	Approx. 20 kg (without flange and probe tube)		
Gas temperature in filter Gas temperature in stack Gas temperature in stack Heating temperature:	Max. 250 °C (480 °F) Unheated probe tube: Max. 1300 °C (2400 °F) Heated probe tube: Max. 200 °C (390 °F) Max. 200 °C (390 °F)		
Temperature control	External, Pt100		
Limit monitoring	External heating controller		
Purge gas flow	Approx. 12 l/min		
Backpurge gas flow	Approx. 80 l/min		
Sample gas throughput	300 ... 1000 l/h		
Heating up time	Approx. 1,5 h (from room temperature to 200 °C)		

Standard lengths, unheated probe tubes [mm]							
SFU-BF NI	200	500	800	1000	1200	1500	2000

Standard lengths, heated probe tubes [mm]						
SFU-BF NI	500	800	1000	1500	2000	
SFU-3V NI	500	800	1000	1500	2000	
SFU-BF NI GL	500	800	---	---	---	

9 Index

A

Assembly steps, overview..... 14

C

Coarse filter..... 12

Compliances..... 38

D

Design of the SFU..... 12

Dimensions..... 38

Disposal..... 37

E

Electrical connection..... 22

Error clearance..... 36

F

Fine filter cartridge..... 26

Fitting position..... 17

I

Installation..... 14

Installation of flange..... 24

Intended use..... 7

M

Maintenance..... 25

Maintenance plan..... 25

O

Operating data..... 39

P

Perform a leak tightness check..... 35

Probe tube..... 12

Product identification..... 9

S

Sample gas connection..... 18

Spare parts..... 26

Standards..... 38

Symbol explanation..... 5

T

Troubleshooting..... 36, 36

Type plates..... 9

W

Warm-up time..... 24

Australia

Phone +61 3 9457 0600
1800 334 802 – tollfree
E-Mail sales@sick.com.au

Austria

Phone +43 (0)22 36 62 28 8-0
E-Mail office@sick.at

Belgium/Luxembourg

Phone +32 (0)2 466 55 66
E-Mail info@sick.be

Brazil

Phone +55 11 3215-4900
E-Mail marketing@sick.com.br

Canada

Phone +1 905 771 14 44
E-Mail information@sick.com

Czech Republic

Phone +420 2 57 91 18 50
E-Mail sick@sick.cz

Chile

Phone +56 2 2274 7430
E-Mail info@schadler.com

China

Phone +86 4000 121 000
E-Mail info.china@sick.net.cn

Denmark

Phone +45 45 82 64 00
E-Mail sick@sick.dk

Finland

Phone +358-9-2515 800
E-Mail sick@sick.fi

France

Phone +33 1 64 62 35 00
E-Mail info@sick.fr

Germany

Phone +49 211 5301-301
E-Mail info@sick.de

Great Britain

Phone +44 (0)1727 831121
E-Mail info@sick.co.uk

Hong Kong

Phone +852 2153 6300
E-Mail ghk@sick.com.hk

Hungary

Phone +36 1 371 2680
E-Mail office@sick.hu

India

Phone +91-22-4033 8333
E-Mail info@sick-india.com

Israel

Phone +972-4-6881000
E-Mail info@sick-sensors.com

Italy

Phone +39 02 27 43 41
E-Mail info@sick.it

Japan

Phone +81 (0)3 5309 2112
E-Mail support@sick.jp

Malaysia

Phone +603 808070425
E-Mail enquiry.my@sick.com

Netherlands

Phone +31 (0)30 229 25 44
E-Mail info@sick.nl

New Zealand

Phone +64 9 415 0459
0800 222 278 – tollfree
E-Mail sales@sick.co.nz

Norway

Phone +47 67 81 50 00
E-Mail sick@sick.no

Poland

Phone +48 22 837 40 50
E-Mail info@sick.pl

Romania

Phone +40 356 171 120
E-Mail office@sick.ro

Russia

Phone +7-495-775-05-30
E-Mail info@sick.ru

Singapore

Phone +65 6744 3732
E-Mail sales.gsg@sick.com

Slovakia

Phone +421 482 901201
E-Mail mail@sick-sk.sk

Slovenia

Phone +386 (0)1-47 69 990
E-Mail office@sick.si

South Africa

Phone +27 11 472 3733
E-Mail info@sickautomation.co.za

South Korea

Phone +82 2 786 6321
E-Mail info@sickkorea.net

Spain

Phone +34 93 480 31 00
E-Mail info@sick.es

Sweden

Phone +46 10 110 10 00
E-Mail info@sick.se

Switzerland

Phone +41 41 619 29 39
E-Mail contact@sick.ch

Taiwan

Phone +886 2 2375-6288
E-Mail sales@sick.com.tw

Thailand

Phone +66 2645 0009
E-Mail tawiwat@sicksgp.com.sg

Turkey

Phone +90 (216) 528 50 00
E-Mail info@sick.com.tr

United Arab Emirates

Phone +971 (0) 4 88 65 878
E-Mail info@sick.ae

USA/Mexico

Phone +1(952) 941-6780
1 (800) 325-7425 – tollfree
E-Mail info@sick.com

Vietnam

Phone +84 8 62920204
E-Mail Ngo.Duy.Linh@sicksgp.com.sg

More representatives and agencies
at www.sick.com

