

General Specifications

Model DT450G
Dust Monitor

EXA DT

GS 11K01C01-01E

■ GENERAL

Powder is used in many industries including ceramics, cement, chemicals, pharmaceutical and food. In their processes, powder is collected in order to reduce the loss incurred in the process. Dust emissions from industrial plants are limited by the air pollution control law, local regulations or other guidelines. Each industrial facility is required to be maintained so that its dust emissions do not exceed the allowable level.

Air pollution control systems such as bag filters and electrostatic precipitators are used to separate particulate or dust from the gas stream before it is exhausted into the atmosphere. To maintain the dust concentration of the emission gas below the specified level through effective operation of the control system, it is essential to continuously monitor the dust concentration of the exhaust gas.

Based on installation and application experiences with the existing DT400G model, the microprocessor-based DT450G Dust Monitor features improved operability and reliability. Features include one-touch automatic range setup in response to process conditions and automatic drift compensation. Also, the DT450G can measure at a process temperature of up to 250°C, allowing it to cover a wide range of applications.

■ FEATURES

- * Drift compensation
- * Direct measurement at a process temperature of up to 250°C
- * One-touch, automatic setup of range appropriate for the process conditions
- * Inductive Electrification: Probe is stain resistant and requires minimal maintenance
- * Integrated design allows for easy installation
- * Maintenance-free operation for a long period

■ SPECIFICATIONS

Measurement objects: Solid particles in gas
Particle size; 0.3 μm or greater
Measurement range; 0.1 mg/m^3 to 1 kg/m^3
Measurement principle: Inductive Electrification
Process conditions:
Temperature; 250°C or less
Pressure; 200 kPa or less
Gas flow rate; 4 m/s or greater
(approx. 30 m/s max)
Humidity; 40%RH or less
Input surge voltage; 100 V or less
(if 500 V or greater, converter may be damaged.)



Measurement range setting:

Range setup; One-touch automatic setup or manual setup (Measurement range does not directly represent dust concentration. To know the absolute value of dust concentration, the relationship between the output signal and the dust concentration should be obtained by laboratory analysis or relevant way.)

Note : With one-touch automatic setup function, measurement range is set so that the dust concentration of the process corresponds to a set point of setting level. In manual setup, the measurement range is set by gain (x1, x10, x100, x1000, x10000).

Setup range; Variable (10 to 50%, 10% step)
Analog output signal:

4-20 mA DC, insulated, load resistance;
500 Ω

Contact output signal (high/low alarm):

Contact capacity; 5 A, 240 V AC or 24 V DC

Setting range; 1 to 99% (1% step) of
measurement span

Contact type: NO (closed when alarm contact is activated) or NC, 2 outputs

Note: Relay is energized when alarm contact is activated.

Damping time constant:

10 to 300 seconds, 10 second step

Relay output time constant:

10 to 180 seconds, 10 second step

Ambient conditions:

Temperature; -20 to 45°C

Humidity; 95%RH or less
(non-condensing)

Vibration; 5 m/s^2 (0.5 G) or less

Construction: Integrated converter and detector,
protection rating IP64

Direct insertion

| | |
|--|--|
| <p>Materials: Sensor probe; Stainless steel (316 SS) Insulation of sensor; PEEK Case; Aluminum</p> <p>Finish: Polyester resin coated</p> <p>Colors: Case; Silver gray (Munsell 3.2PB 7.4/1.2) Cover; Mint green (Munsell 5.6PG 3.3/2.9)</p> <p>Power supply: Rating; 100 to 120 V AC, 200 to 240 V AC Operating voltage range; 90 to 132 V AC, 180 to 264 V AC</p> <p>Power consumption: 8 VA</p> | <p>Wiring connection: 2 ports · DIN with PG11 cable gland (applicable to cable with 5 to 10 mm OD) for power wiring · DIN with PG11 cable gland (applicable to cable with 5 to 10 mm OD) for output wiring</p> <p>Note: Use one cable for analog output and contact signals.</p> <p>Air purge: Connection; Rc1/4 Air source; Clean, dry air equivalent to instrument air at process pressure + 50 kPa Air consumption; Approx. 50 NI/min</p> <p>Mounting: Socket (dedicated) or flange</p> <p>Weight: Approx. 2.3 kg (excluding flange)</p> <p>Dimensions: 172 W x 173 H x 672 D mm</p> |
|--|--|

MODEL AND SUFFIX CODES

1. Dust Monitor

| Model | Suffix Code | Option Code | Description |
|--------------------|-------------|-------------|--|
| DT450G | ----- | ----- | Dust monitor (heat resistant up to 250°C) |
| Analog output | -5 | ----- | 4-20 mA DC analog output + fine adjustment for measuring range |
| Power supply | -2 | ----- | 200-240 V AC, 50/60 Hz |
| | -5 | ----- | 100-120 V AC, 50/60 Hz |
| Probe length | -05 | ----- | 460 mm |
| Sensor material | -1 | ----- | 316 SS |
| Air purge | -A | ----- | With air purge |
| Instruction Manual | -J | ----- | Japanese |
| | -E | ----- | English |
| Mounting | -W | ----- | Socket mounting (welding socket) |
| | -A | ----- | Flange mounting (ANSI Class 150 2 1/2 RF) |
| | -K | ----- | Flange mounting (JIS 5K 65 FF) |
| | -M | ----- | Flange mounting (JIS 10K 80 FF) |
| | -P | ----- | Flange mounting (JIS 10K 100 FF) |
| | -T | ----- | Flange mounting (JPI Class 150 2 1/2 RF) |
| — | -A | ----- | Always -A |
| Option | | /TC | Probe: Teflon coated |

Note: Teflon coated probe (option code "/TC") is recommended to prevent the insufficient insulation by dust and moisture deposited on sensor.
 Teflon coated probe is designed to operate at a temperature not exceeding approximately 150°C.

2. Spare Parts

| Item | Part Number | Qty |
|-------------------------|-------------|-----|
| O-ring | B1026ER | 1 |
| Flange assembly: | | |
| JIS 5K 65 FF | K9479DA | 1 |
| JIS 10K 80 FF | K9479DB | 1 |
| JIS 10K 100 FF | K9479DC | 1 |
| JPI Class 150 2 1/2 RF | K9479DE | 1 |
| ANSI Class 150 2 1/2 RF | K9479DD | 1 |
| Socket | K9479CA | 1 |
| Bolt | L9800TC | 2 |

DIMENSIONS

1. Flange Mounted Model

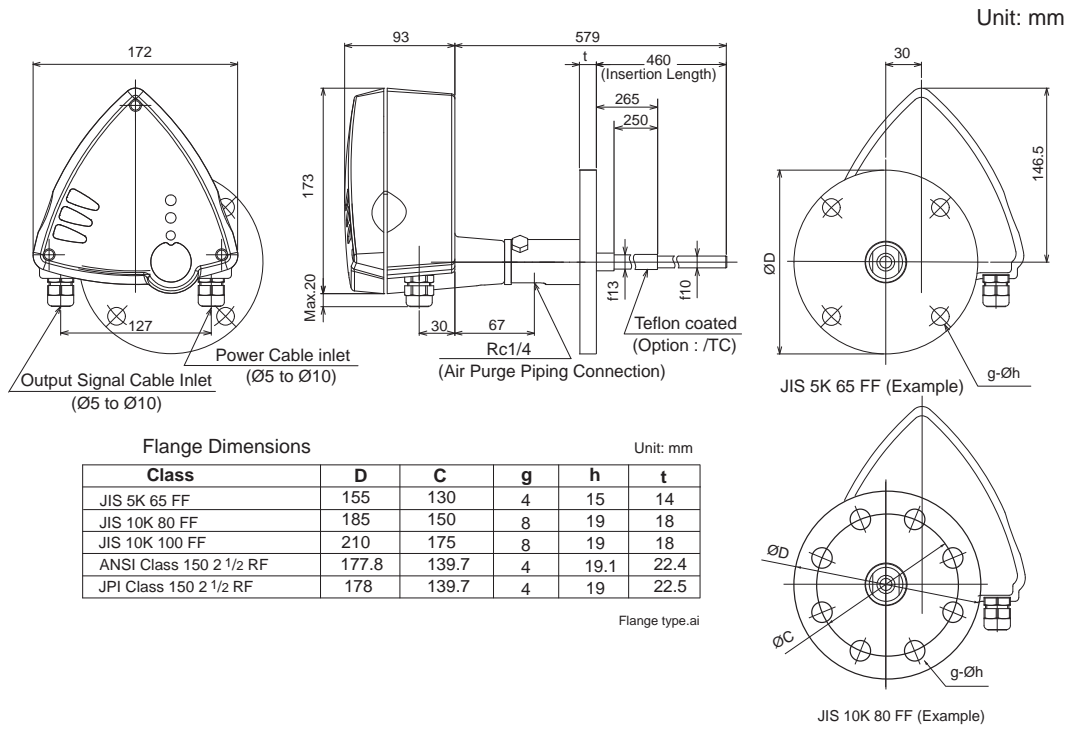

2. Welding Socket Mounted Model

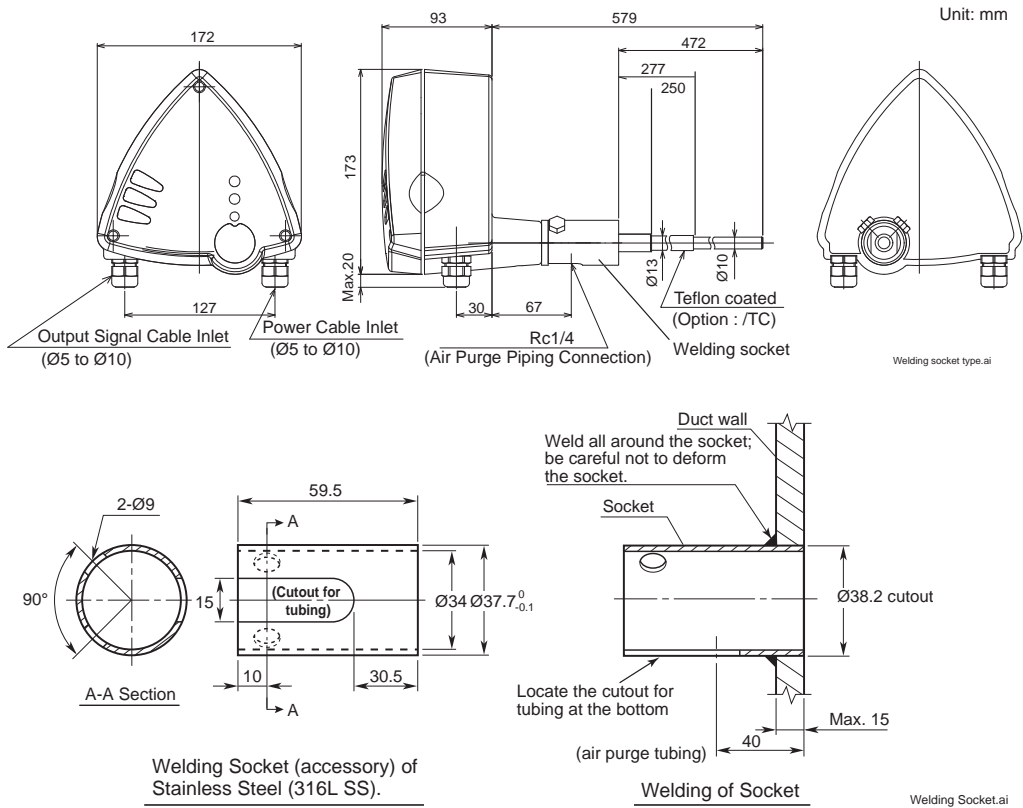

■ WIRING DIAGRAM

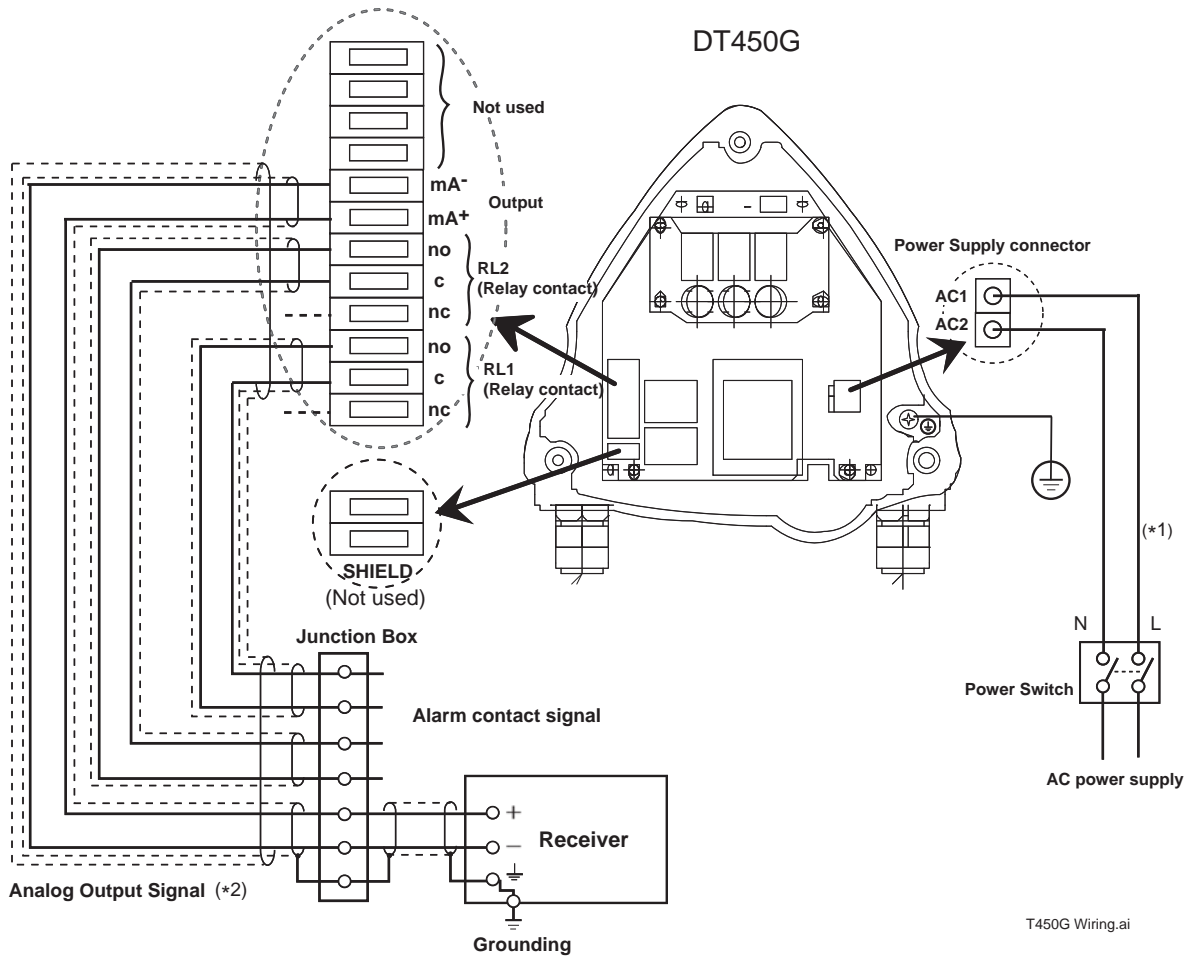

(*1) The nominal cross-section of each conductor should be 1.5 mm²
 (*2) The nominal cross-section of each conductor should be not more than 0.5 mm²

- Notes:**
- The above wiring diagram shows the one when using no contacts. Connect wires to terminals nc and c when using nc contacts.
 - This terminal is used for the grounding on the receiver side.

■ INSTALLATION CONDITIONS

1. Installation Location

- (1) The pipe or duct where the sensor is to be installed should have a straight line with a length (L) of at least five times the pipe/duct diameter. Ensure that there are no valves, dampers or other obstructions in the section $\frac{5}{8}L$ upstream and $\frac{3}{8}L$ downstream of the sensor.
- (2) The sensor can be inserted at any angle between horizontally and vertically with the sensor top facing down.
- (3) The pipe or duct should be metallic and must be grounded.
- (4) The sensor should be preferably positioned in the center of the pipe or duct.
- (5) The output signal should not be affected by noise from plant equipment or constructions. The DT450G should be installed at least 20 m away from an ESP, if used. When the DT450G is to be used to monitor a bag filter or other dust collectors, it should be installed upstream of a blower.
- (6) A place subject to vibration should be avoided.

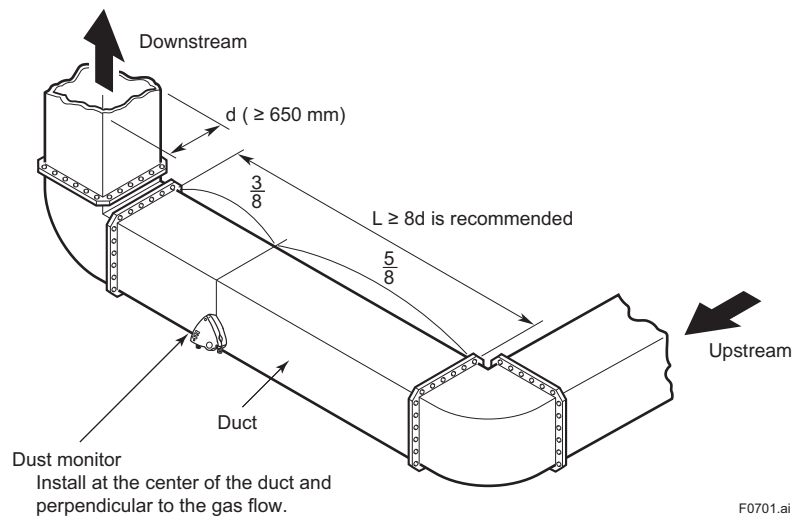

2. Installation Procedure

2.1 When Mounting to Flange

Prepare the DT450G with a flange that meets the specified standard. Prepare the tie-in flange at the connection port of the duct or pipe.

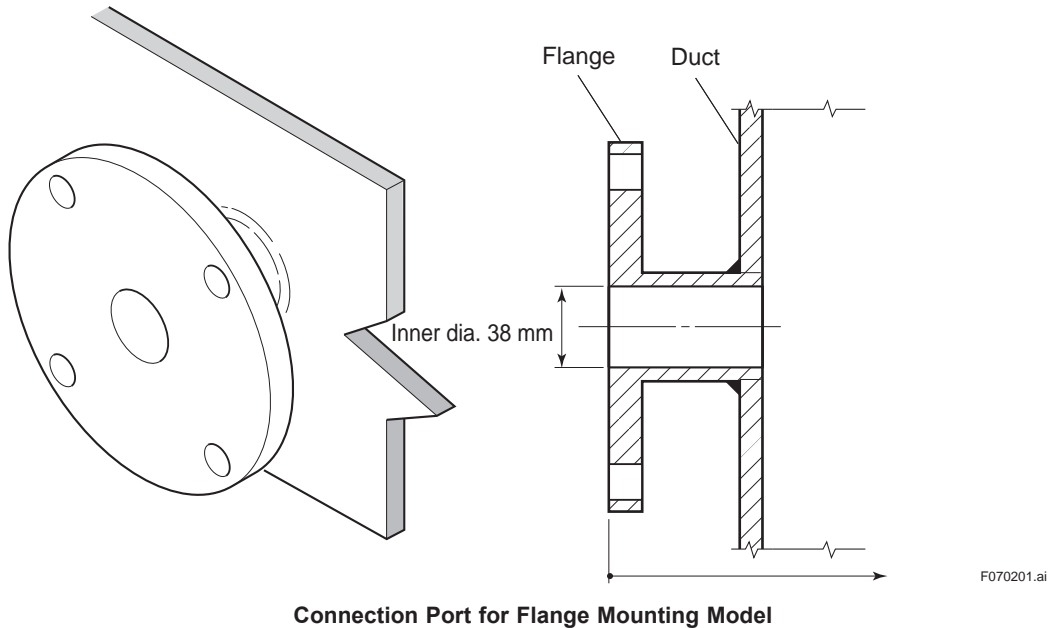

Water drops on the insulation of the sensor probe can interfere with accurate measurement.

When the process gas temperature and pressure are high and if the gas is cooled at or near the insertion hole, the sensor must be purged with air to prevent condensation from forming on the inside of the neck of the flange. If the ambient temperature goes below 0°C, the flange neck should be insulated.

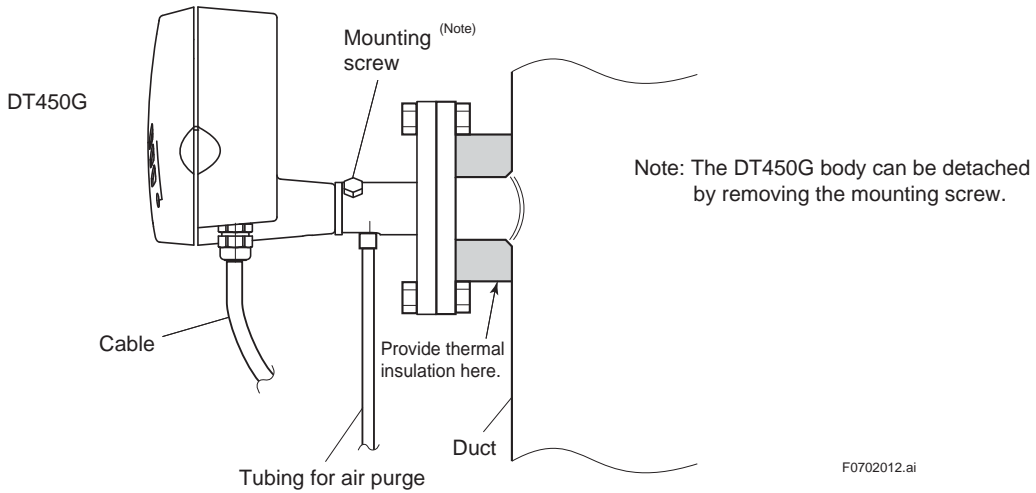

2.2 Socket Mounting

A dedicated socket supplied with the DT450G should be generally used. Weld the socket to a hole in the pipe or duct following the instructions below.

- The standard insertion length of the sensor probe is 460 mm.
- Drill a 38 mm diameter hole in the pipe or duct. The outside diameter of the dedicated socket is 38 mm.
- The socket (316L SS) should be welded tight without deforming the socket. When the socket is to be mounted on the vertical plane of the pipe/duct, mount it so the piping slot faces down.

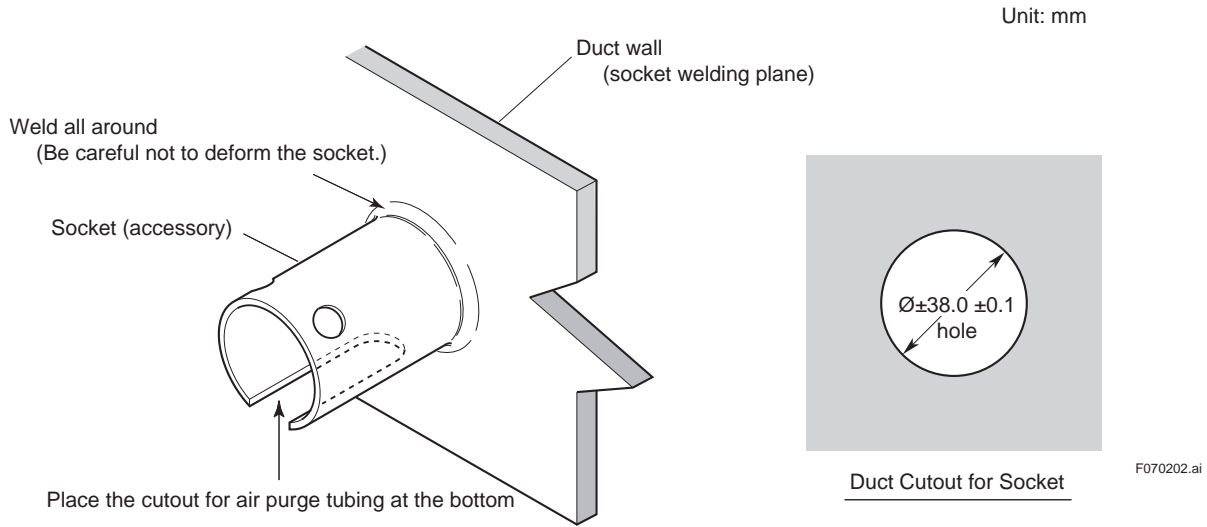

Connection Port for Socket Mounting Model

3 Installation Space

The DT450G Dust Monitor may need to be detached for cleaning the sensor probe. Also, without detaching the monitor from the pipe or duct, fuse replacement or other maintenance work may be done. For the safety of such maintenance work, a sufficient maintenance space should be secured.

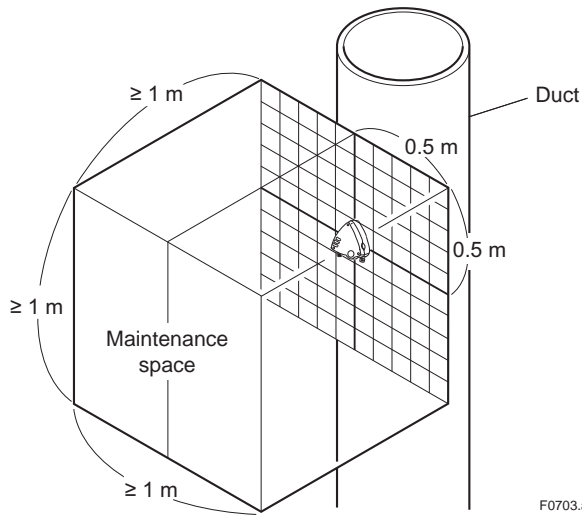

Maintenance Space at Installation Location of DT450G Dust Monitor

Specification of Dust Monitor Requirements

Thank you for the inquiry on our dust monitor. Please check the appropriate box and fill in blanks below.

1. General

- (1) Company name: _____
- (2) Your name: _____ Department: _____ phone: _____
- (3) Plant name: _____
- (4) Measuring object (location): _____
- (5) Purpose: Indication Recording Alarm Control
- (6) Power supply: _____ V AC

2. Process Conditions

- (1) Temperature: _____ to _____ °C; normal _____ °C
- (2) Pressure: _____ to _____ kPa; normal _____ kPa
- (3) Speed of gas flow: _____ to _____ m/s
- (4) Humidity: _____ to _____ kg/kg vol%H₂O
- (5) Others: _____

3. Ambient Conditions of Installation Location

- (1) Temperature: _____ °C
- (2) Location: Indoor Outdoor
- (3) Vibration: Not present Present
- (4) Sensor length: 460 mm _____
- (5) Flange: JIS ANSI JPI None (socket)
- (6) Instrument air: Not available Available
- (7) Others: _____

4. Requirements

- (1) Measuring object: _____
- (2) Composition of particle: _____
- (3) Particle size: _____
- (4) Measurement range: _____ to _____ mg/l
- (5) Output: 4-20 mA DC Not required
- (6) Others: _____

| | |
|----------------|--|
| CAUTION |  <ul style="list-style-type: none"> ● For the safe use of the product, read the instruction manual carefully before use. |
|----------------|--|