

1. GENERAL

1.1 DIMENSIONS

The dimensions of the electrodes are shown in figure 1-5. These figures also detail the electrode construction. The dimensions of the combined Redox electrodes meet the DIN standard (DIN 19263)

1.2 SPECIFICATIONS

Type SC29-PTP29, SC29C-PTP29, SC29D-PTP29

Combined Redox/reference, electrode

(Non flow type)

Temp range	: 0 to 120 °C
Pressure range	: max 500 kPa
Membrane	: Solid Platinum cup
Diaphragm	: Porous PTFE (impedance <math>< 10 \text{ k}\Omega</math>)
Reference system	: Ag/AgCl Sat'd. KCl

Type SC29-PTC55

Combined Redox/reference electrode

(Flow type)

Temp range	: 0 to 120 °C
Pressure range	: max 500 kPa
Membrane	: Solid Platinum cup
Diaphragm	: Ceramic (impedance <math>< 10 \text{ k}\Omega</math>)
Reference system	: Ag/AgCl 3.3m. KCl

Type SC29-PTG29

Combined Redox/glass electrode

Temp range	: 0 to 100 °C
Pressure range	: max 500 kPa
Membrane	: Solid Platinum cup
Glass	: general purpose pH glass

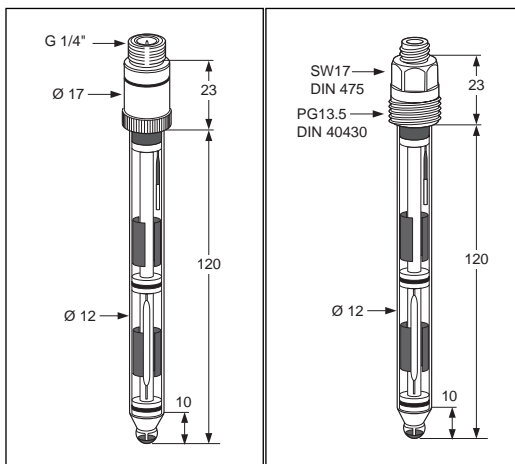

Fig. 1. SC29-PTP29

Fig. 2. SC29D-PTP29

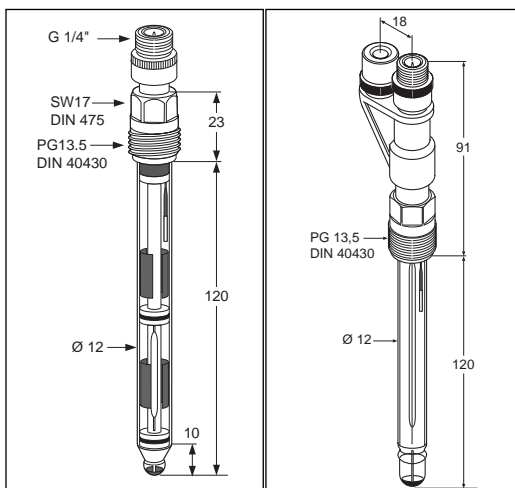

Fig. 3. SC29C-PTP29

Fig. 4. SC29C-PTC55

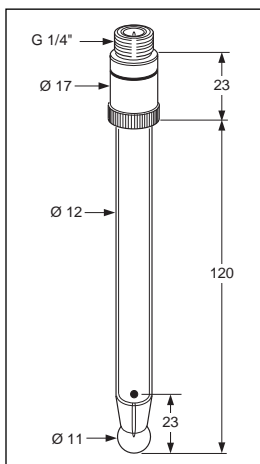

Fig. 5. SC29-PTG29

NOTES:

- The thickness of the metal membrane is limited and consequently, the lifetime is limited for applications that are aggressive to the metal itself, e.g.:
 - Hydrochloric acid with free chlorine, concentrated hypochloric acid at high temperatures (for platinum)
- The impedance of the glass membrane will decrease by 50% at any temperature increase of 10°C

1.3 APPLICATION

Generally, the combined Redox/reference electrodes are for applications where installing of separate electrodes is not possible. The combined Redox/reference electrodes are steam sterilisable and can be applied for general purpose. The combined Redox/pH electrode can be used for processes with a constant pH value or for processes of which the Redox potential is linear on the pH value in order to achieve pH compensated redox potential.

2. INSTALLATION

2.1. PREPARATION FOR USE

After removing the dust cap from the connector and the protective cover from the measuring part, the electrode is ready for use.

NOTE:

For accurate measurements with a Redox/glass electrode, a gel-layer must be formed on the glass membrane surface. For this reason the membrane should be soaked for 24 hours before the electrode is used.

When an electrode has been stored dry and you need to use it immediately (there is no time for soaking) you may do so, but as a result frequent re-calibration will be required until the gel-layer is formed.

The electrode, when despatched has a protective cover filled with an electrolyte around

the glass membrane which ensures you can use the electrode immediately.

2.2 MOUNTING

2.2.1. MOUNTING THE FITTING

The mounting of the combined Redox/pH electrode in a fitting should be carried out as shown in the following figures. All electrodes with a PG13.5 cap (SC29C- / SC29D-) can also be mounted directly into a PG13.5 process connection

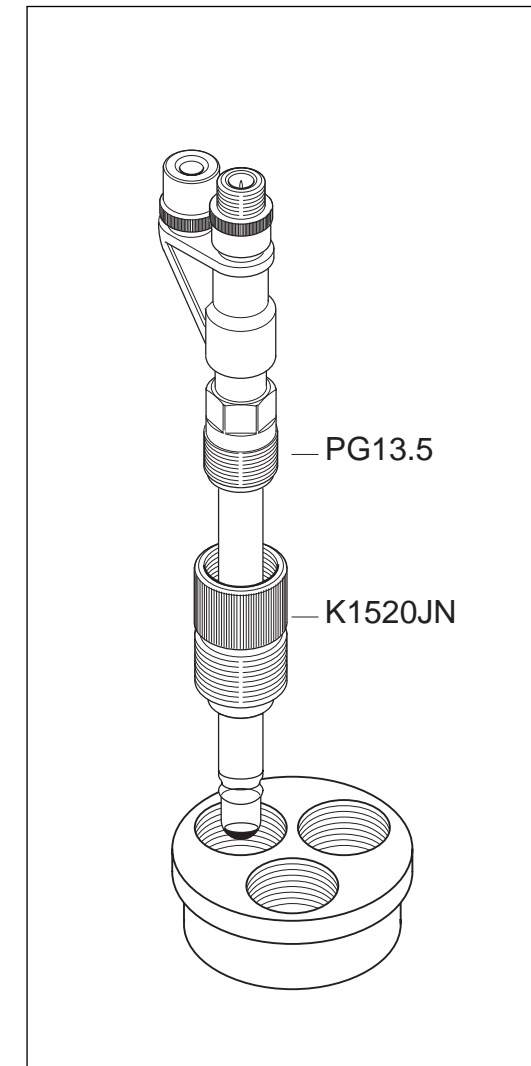

Fig. 6. Mounting PG13,5 in Yokogawa fitting using the adapter K1520JN (PVC-C) or K1500DV (PVDF)

The SC29-..... electrodes can be mounted in all Yokogawa fittings as shown in the figure below:

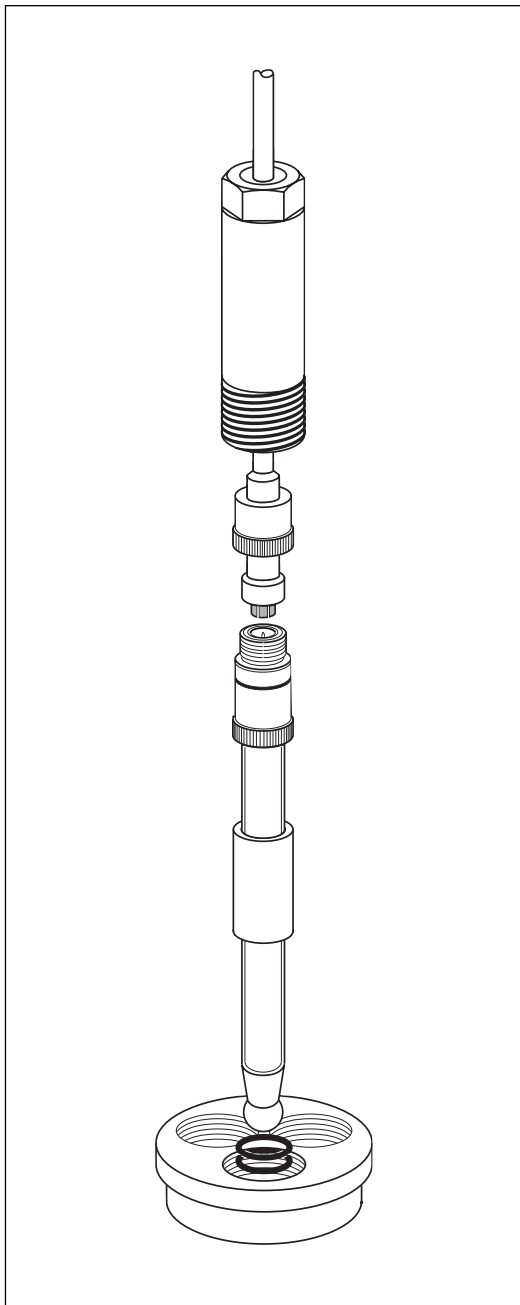

Fig. 7. Standard mounting with mounting set
FP20-R12(M), FP20-S12(M)

2.2.2. ELECTRODE CABLES

The electrode must be fitted with an electrode cable, marked with a blue strip. To meet the highest accuracy the electrode cable of Yokogawa, type WU20(D)-LT.. (length 1-25mtr.) is recommended. Electrodes with model code SC29 and SC29C use a WU20-cable. Electrodes with model code WU20D use a WU20D cable. Cables come in a variety of lengths:

Model	Suffix	Description
WU20(D)		Electrode cable
Type	-PC	COAX
	-LT	TRIAx
Length (mtr.)	01	1 mtr.
	02	2 mtr.
	05	5,5 mtr.
	10	10 mtr.
	15	15 mtr.
	20	20 mtr.
	25	25 mtr.

NOTE:

For immersion applications (PD20- fitting types) in liquids with higher temperatures (>70°C) the electrode cable, type WU20-PC.. of Yokogawa can be used with the addition of a protective hose (/PHα α) to prevent moisture ingress.

2.3. FUNCTIONAL CHECK AND CALIBRATION

A check for correct functioning of a combined electrode can easily be made using a buffer solution of 6.87 and/or 4.01 pH with quinhydrone.

When 1-20 grams (± 1 teaspoon) quinhydrone is added to each buffer, it will produce a stable redox potential of 96 mV and 265 mV respectively. Mostly only 1-point calibrations are performed. Some analysers also have the possibility to adjust the slope (2-point calibration)

3. USE AND MAINTENANCE

3.1. CLEANING

The electrode should be cleaned with care using a soft cloth or tissue soaked in soap suds, alcohol, acetone or white spirit. If the deposit is persistent it may be removed using a domestic washing liquid diluted with water. This method can affect the sensitive metal layer of the electrode and consequently precaution is required.

3.2 STORAGE

When an electrode of the type SC29C-PTC55 is to remain unused for a long period, it is necessary to fill the electrode completely with electrolyte solution, to close the refill opening with the rubber plug and to protect the diaphragm against drying out by fitting the protective cover. This cover must also be filled with electrolyte solution.

K1520VA 3.3m. KCl sol 250ml (normal)
K1520VN 3.3m. KCl sol. 250ml (thickened)

3.3 INSULATION

It is essential that a high insulation resistance is maintained between the electrode and its screen. This means that the correct electrode cable is used and the connector is kept dry and clean at all times. If a connector box is used this too must be an approved type and be maintained in a clean and dry condition.

User Manual

Directions for use combined Redox Electrodes

YOKOGAWA ◆ IM 12C6J1-30E-H
04-208 (A) Q

Printed in The Netherlands,
Subject to change without notice
Copyright©