

# MESR901 Modbus Gateway



# KEP

**KESSLER-ELLIS PRODUCTS**

10 Industrial Way East  
Eatontown, NJ 07724

800-631-2165 • 732-935-1320

Fax: 732-935-9344

**kep.com**

<http://www.kep.com>

990352 04/01/15





# Contents

<b>1. Introduction</b>	<b>4</b>
About MESR901 Modbus Gateways	4
MESR901 Modbus Gateway Model Numbering	5
MESR901 Modbus Gateway Features	5
Configuration Software	5
<b>2. MESR901 Modbus Gateway Hardware</b>	<b>6</b>
Package Checklist	6
MESR901 Modbus Gateway Enclosures and Mounting	6
LED Indicators	7
E1/E2 Ethernet Link LED	7
Ready LED	7
Serial Port LEDs	7
Mode Switch	8
Ethernet Connector	8
Serial Port Connectors	9
Power Connector	10
Mounting Hardware	10
<b>3. Modbus Gateway Setup and Connections</b>	<b>11</b>
Connecting the Power Supply	11
Connecting MESR901 Modbus Gateways to Modbus networks	11
Connecting the MESR901	12
Connecting MESR901 Modbus Gateways to a Network	13
Network Connection (10BaseT/100BaseTX)	13
MESR901 Modbus Gateway Configuration Connections	13
Installing Modbus Configuration Manager Software	14
Configuring the MESR901 Modbus Gateway via the Network Connection	18
Configuring with Modbus Configuration Manager	18
Configuring with the Web Interface	32
Configuring the MESR901 Modbus Gateway on Networks without a DHCP Server	33
Configuring the MESR901 Modbus Gateway via the Serial Port (Console Mode)	36
MESR901 Modbus Gateway Operational Connections	38
Using MESR901 Modbus Gateways in Direct IP Mode	38
Initiating a Hardware Reset on the Modbus Gateway	39
Reloading Factory Defaults	39
<b>4. Upgrading the Modbus Gateway Firmware</b>	<b>40</b>
Downloading Firmware Files	41
Uploading the Firmware to the Modbus Gateway	41
<b>5. Diagnostics</b>	<b>42</b>
Testing a Modbus Gateway Connection	43
Monitor Function	44
Ethernet Master and Serial Slaves	45
<b>6. Application Examples</b>	<b>45</b>
Serial & Ethernet Masters, Serial & Ethernet Slaves	51
Serial Masters, IP Slaves	53
Identical Hard Coded Slaves	59
Identical Production Lines	60
<b>7. Modbus Help</b>	<b>61</b>
Modbus ASCII/RTU Basics	61
Hints and Tips	62
<b>8. Appendices</b>	<b>63</b>
<b>Appendix A: Default Gateway Settings</b>	<b>64</b>
<b>Appendix B: Product Specifications</b>	<b>65</b>
General Specifications	66
Controls, Indicators and Connector Specifications	67
Serial Interface Specifications	68
Network Specifications	69
<b>Appendix C: Dimensional Diagrams</b>	<b>70</b>
<b>Appendix D: Connector Pinouts</b>	<b>71</b>
MESR901 Serial Port Pinouts	71
Standard Ethernet Cable RJ-45 Pin-out	72
<b>9. Glossary</b>	<b>73</b>

# 1. Introduction

Thank you for purchasing a MESR901 Modbus Gateway product! This product has been manufactured to the highest standards of quality and performance to ensure your complete satisfaction.



Figure 1. An MESR921 Modbus Gateway

## About MESR901 Modbus Gateways

**MESR901 Modbus Gateways** connect Modbus networks (RS-232, RS-422 or RS-485) to Ethernet networks, allowing the Modbus network to become a node on the network. The serial ports can be accessed over a LAN/WAN using Direct IP Mode connections. MESR901 Modbus Gateways feature 10BaseT or 100BaseTX copper network media. MESR901 Modbus Gateways are built for use in industrial environments, featuring an IP30 approved slim line DIN rail mountable case. They operate from a range of DC power supply voltages and feature pluggable terminal block power connectors. An external power supply, sold separately, is required. MESR901 units have one Ethernet port and one serial port.



## **MESR901 Modbus Gateway Model Numbering**

<u>Model</u>	<u>Description</u>
--------------	--------------------

MESR901	Modbus Gateway with 1 Ethernet Port and 1 Serial Port
---------	---

## **MESR901 Modbus Gateway Features**

- Four series models
  - MESR901-x (single serial port, single Ethernet Port)
  - MESR902T-x (two serial ports with pluggable terminal blocks, single Ethernet port)
  - MESR921-x (single serial port, two Ethernet Ports)
  - MESR922T-x (two serial ports with pluggable terminal blocks, two Ethernet Ports)
- On models with two Ethernet Ports, the second port is an Ethernet pass-through port. This port functions much like an unmanaged switch.
- Fiber models available for each of the above series
- Multi-interface serial ports
- DB-9M and pluggable terminal block serial port connector options
- All ports are software selectable as RS-232, RS-422 or RS-485 2- and 4-wire
- Configuration can be done via network or direct serial connection
- Slim line DIN rail mountable case
- Accepts DC power over a wide voltage range
- 10/100 Mbps Ethernet with Auto Selection, Auto MDI/MDIX
- LAN and WAN Communications
- TCP Client or Server operation - configurable
- Firmware Upload for future revisions/upgrades
- Software Support - Windows 2000, XP (32/64 bit), 2003 Server (32/64 bit), Vista (32/64 bit), 2008 Server (32/64 bit), Windows 7 (32/64 bit)
- Configuration of Ethernet and serial port settings using Vlinx Manager software

## **Configuration Software**

The configuration software enables you to find connected Modbus gateways, configure them, upgrade Modbus gateway firmware, and save/load configuration files. It features a graphical user interface (GUI) that is convenient and easy to use.

## 2. MESR901 Modbus Gateway Hardware

MESR901 Modbus Gateways are enclosed in DIN rail mountable enclosures and feature LED indicators, power, Ethernet and serial connectors and a recessed Mode switch.

### Package Checklist

MESR901 Modbus Gateways are shipped with the following items included:

- MESR901 Modbus Gateway Module
- Quick Start Guide
- CD with User Manual, Quick Start Guide and firmware, and configuration software.

### MESR901 Modbus Gateway Enclosures and Mounting

The MESR901 Modbus Gateway models are built into enclosures that are DIN rail mountable.



Figure 2. Front View of an MESR901 Modbus Gateway

## LED Indicators

MESR901 Modbus Gateways have three types of LED indicators: **Ethernet Link LEDs**, a **Ready LED** and **Serial Port LEDs**.



Figure 3. Ready Ethernet Port LEDs on 1 and 2 Ethernet Port Modbus Gateways

### E1/E2 Ethernet Link LED

The **Ethernet Link** LED (E1 or E2) illuminates (green) if the Ethernet is connected. When the LED is blinking it indicates that there is data traffic on the Ethernet link.

E1 is used for all models to connect to the network. E2 is used on MESR92X models, and is a pass-through Ethernet connector.

### Ready LED

The **Ready** LED (green) blinks if the system is operating correctly, once per second in normal operating conditions, or three times per second in reset, configuration mode, or when loading factory defaults. If the LED is off or steady, it indicates the system is not operating correctly.

### Serial Port LEDs

MESR901-x Modbus Gateways feature one serial port. MESR902D, and MESR902T-x Modbus Gateways feature two serial ports. Each serial port has an associated LED. Serial Port LEDs blink (green) when data is being transmitted or received on the serial port. When the LED is On it indicates the serial port is open.



Figure 4. Serial Port LEDs on 1 and 2 Serial Port Modbus Gateways

## Mode Switch

A recessed momentary reset switch is located on the top of the enclosure. To activate the switch, insert a small plastic tool through the hole in the enclosure and press lightly.

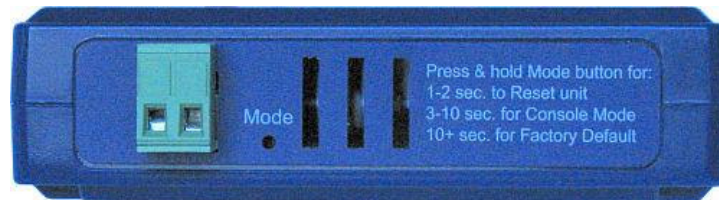

Figure 5. Mode Switch

The Mode switch can be used to:

- Initiate a Hardware Reset
- Enter Console Mode
- Reload factory defaults

*Note: Refer to Section 3. Modbus Gateway Setup and Connections for more information on using the Mode switch.*

## Ethernet Connector

The MESR901 Modbus gateway uses a 10BaseT/100BaseTX network connection with an RJ45 receptacle. The Modbus gateway is connected to a standard Ethernet network drop using a straight-through RJ45 (male) Ethernet cable.



Figure 6. Ethernet Connectors.

**Note:** Refer to Appendix D for connection pin-outs.

## Serial Port Connectors

- MESR901 Modbus Gateways feature one serial port and use a DB-9M connector for RS-232 and a five-position removeable terminal block for RS-422 and RS-485 connections.



Figure 8. DB-9 Female Serial Port Connector



Figure 9. Five-Position Pluggable Terminal Block

**Note:** Refer to Appendix D for connection pin-outs.

## Power Connector

The power connector is a 2-position pluggable terminal block.



Figure 10. Power Connection

## Mounting Hardware

MESR901 Modbus Gateway modules can be DIN rail mounted. The DIN mounting clip and spring is included on each module.



Figure 11. DIN Clips on Modbus Gateway Modules

## 3. Modbus Gateway Setup and Connections

*Note: In this section devices to be connected to the Modbus gateway's serial connection are simply referred to as the "Modbus network".*

### Connecting the Power Supply

Connect a DC power supply to the power terminals on the top of the Modbus gateway. Polarity of the wires is indicated on the label on the side of the Modbus gateway. Acceptable voltages are between 10 VDC and 48 VDC. The power supply must be capable of supplying 4 Watts for MESR901 units.

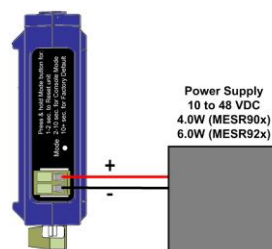

Figure 12. MESR Power Connection

### Connecting MESR901 Modbus Gateways to Modbus networks

MESR901 Modbus Gateways can be configured to connect to Modbus networks using RS-232, RS-422, RS-485 2-wire and RS-485 4-wire.

**RS-232** connections support eight signal lines plus Signal Ground. Signals are single ended and referenced to Ground. Default communications parameters are 9600, 8, N, 1 and no flow control implemented.

**RS-422** connections support two signal pairs: RXA(-), RXB(+) and TXA(-), TXB(+), plus GND. The data lines are differential pairs (A & B) in which the B line is positive relative to the A line in the idle (mark) state. Ground provides a common mode reference.

**RS-485** connections support 2-wire or 4-wire operation.

When configured for **4-wire operation** the connection supports two signal pairs: RXA(-), RXB(+) and TXA(-), TXB(+), plus GND. This makes full-duplex operation possible. The data lines are differential pairs (A & B) in which the B line is positive relative to the A line in the idle (mark) state. Ground provides a common mode reference.

When configured for **2-wire operation** the connection supports one signal pair: DataB(+) and DataA(-) signal channels using half-duplex operation. The data lines are differential with the Data B line positive relative to Data A in the idle (mark) state. Ground provides a common mode reference.

### Connecting the MESR901

The **MESR901** has one serial connection that supports RS-232, RS-422 and RS-485 (2- and 4-wire). The unit has two connectors: a DB-9M connector and a 5-position terminal block.

If you select RS-232 mode when you configure the Modbus gateway, you must connect the Modbus serial network to the Modbus gateway via a serial cable. The MESR901 is a DTE. If the Modbus network is a DTE, use a null modem (cross-over) cable. If the Modbus network is a DCE, use a straight-through cable. DTE and DCE ports are complementary, the **Output** signals on a DTE port are **Inputs** to a DCE port, and **Output** signals on a DCE port are **Inputs** to a DTE port. The signal names match each other and connect pin for pin. Signal flow is in the direction of the arrows. (see figure below)

#### Modem Cable - Straight Cable DB9 to DB9

DTE Device (Computer)		DB9	DTE to DCE Connections	DCE Device (Modem)	DB9
Pin#	DB9	RS-232 Signal Names	Signal Direction	Pin#	DB9
#1	Carrier Detector (DCD)	CD	←	#1	Carrier Detector (DCD)
#2	Receive Data (Rx)	RD	←	#2	Receive Data (Rx)
#3	Transmit Data (Tx)	TD	→	#3	Transmit Data (Tx)
#4	Data Terminal Ready	DTR	→	#4	Data Terminal Ready
#5	Signal Ground/Common (SG)	GND	→	#5	Signal Ground/Common (SG)
#6	Data Set Ready	DSR	←	#6	Data Set Ready
#7	Request to Send	RTS	→	#7	Request to Send
#8	Clear to Send	CTS	←	#8	Clear to Send
#9	Ring Indicator	RI	←	#9	Ring Indicator
Soldered to DB9 Metal - Shield		FGND	→	Soldered to DB9 Metal - Shield	
				FGND	

If you select RS-422 mode, RS-485 2-wire mode, or RS-485 4-wire mode when you configure the Modbus gateway, you must connect the Modbus network appropriately, via the 5-position terminal block.

*Note: Refer to Appendix D for connector pin out information.*

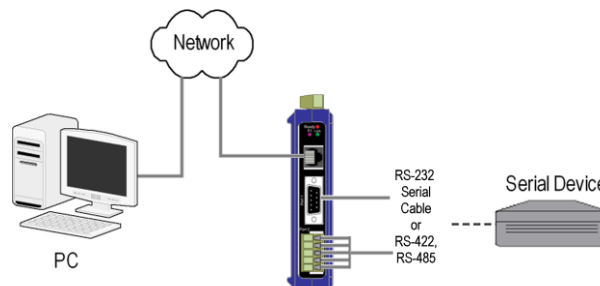

Figure 13. MESR901 Connections



## **Connecting MESR901 Modbus Gateways to a Network**

### **Network Connection (10BaseT/100BaseTX)**

When connecting a Modbus gateway equipped with a 10BaseT/100BaseTX network connection (RJ45 connector) a standard network cable is connected from the Modbus gateway to a network drop. PCs configuring and/or communicating with the Modbus gateway are also connected to the network.

## **MESR901 Modbus Gateway Configuration Connections**

MESR901 Modbus Gateways can be configured over the network or via a serial port.

## Installing Modbus Configuration Manager Software

1. The Modbus Configuration Manager Software is contained on the CD which is packaged with the product. Insert the CD into your CD ROM drive. The software should automatically begin the installation process. If AUTO RUN is disabled on your computer, open the CD drive and double click on the executable file. The file name is Modbus Gateway Manager Vx.x.x.
  - a. The following screen will be displayed on your computer.

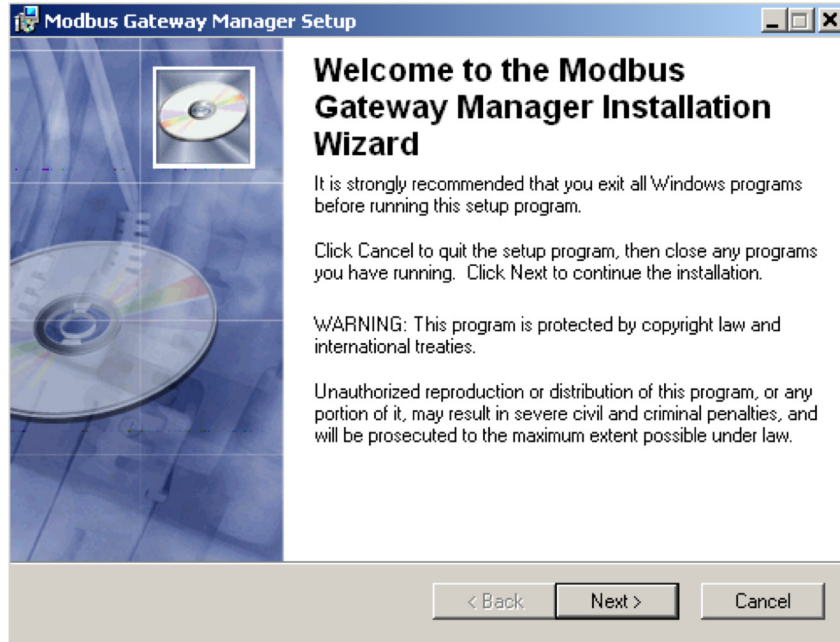

Figure 16. Modbus Gateway Manager Installation Welcome Screen

- b. Click "Next." The License Agreement Screen will be displayed on your computer.

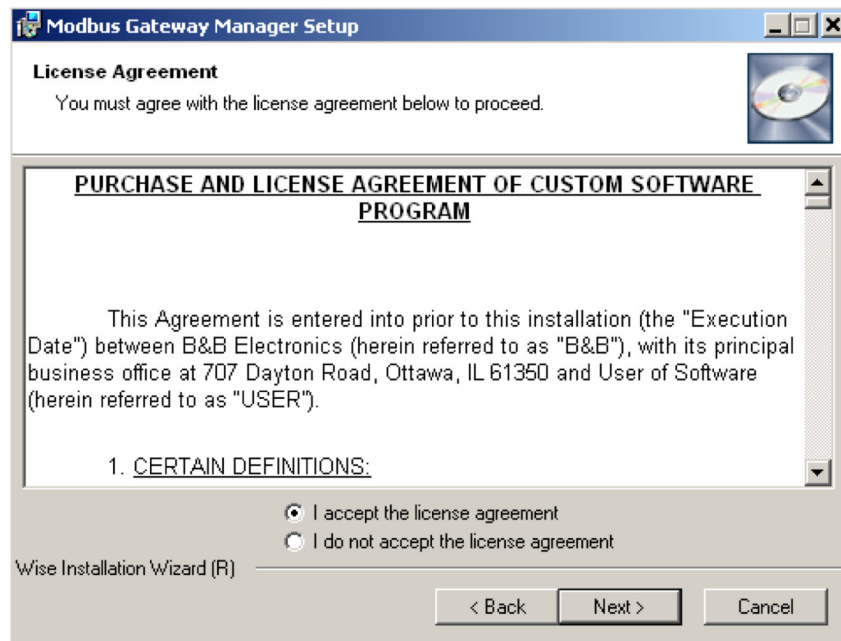

Figure 17. Modbus License Acceptance Screen

- c. Click “Next.” The User Information Screen will be displayed on your computer. Enter your name and organization (optional) and select if the software will be accessible to your account or anyone who uses the computer.

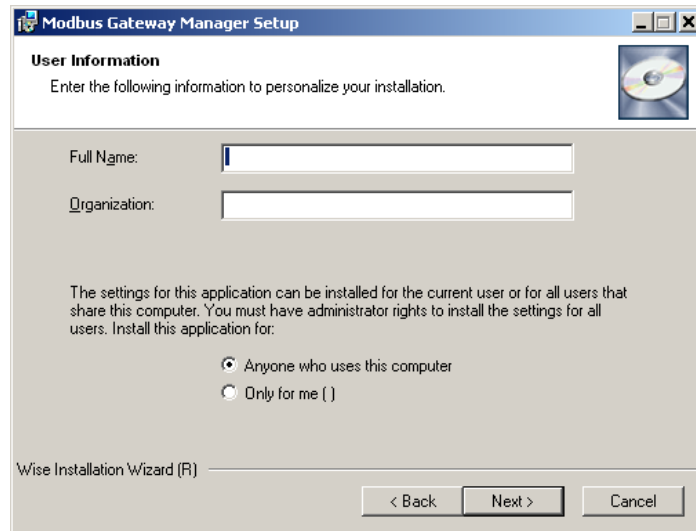

Figure 18. User Information Screen

- d. Click “Next.” The Destination Folder Screen will be displayed on your computer. The default directory is:

C:\Program Files\BB Electronics\Wlinux\Modbus Gateway Manager\

If desired, you can select another location by pressing the “Browse” button.

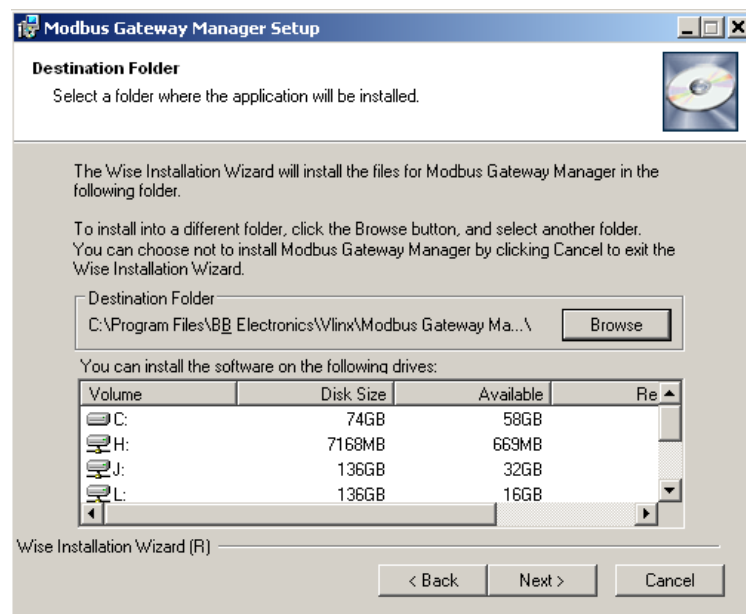

Figure 19. Destination Folder Screen

- e. Click “Next.” The Ready to Install Application Screen will be displayed on your computer. You can select the “Back” button to change destination folder.

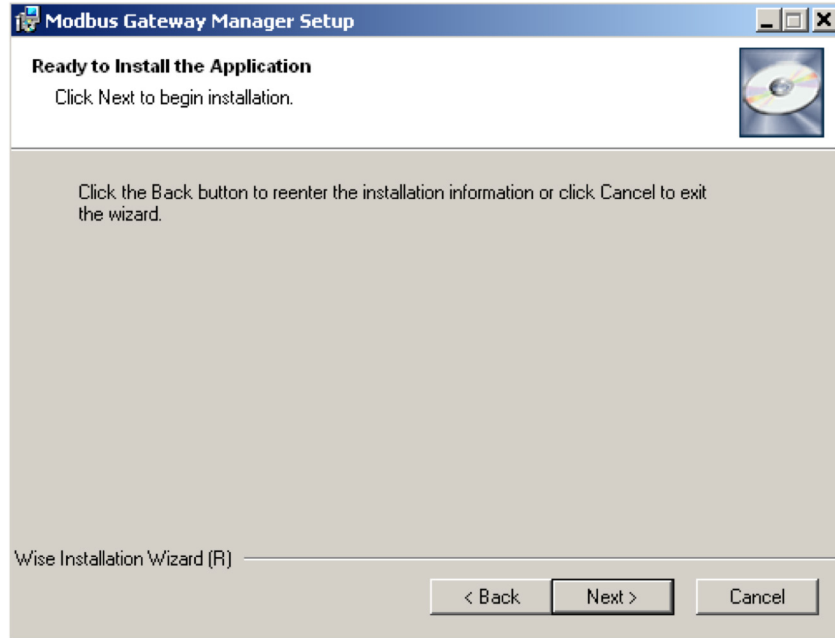

Figure 20. Ready to Install Application Screen

- f. Click “Next.” The software will begin installing.

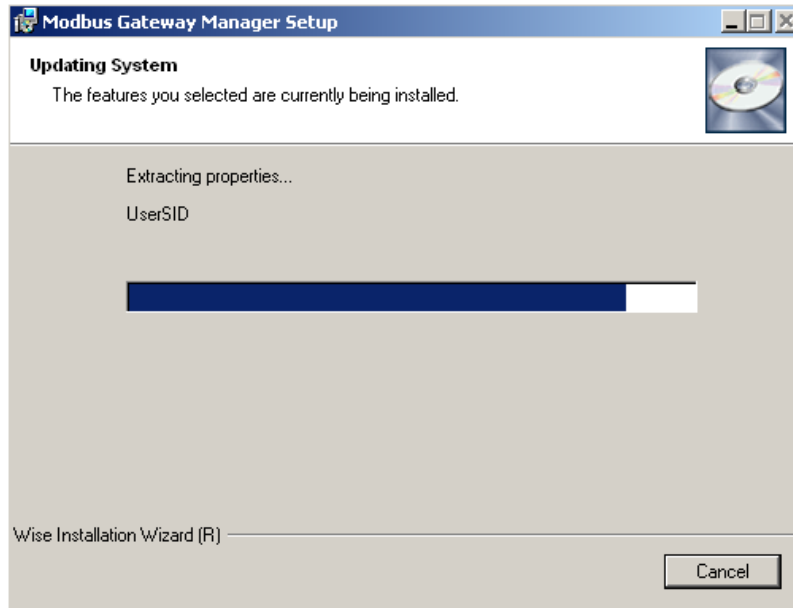

Figure 21. Software Installing Screen

- g. After the installation is complete, an information screen will be displayed containing contact information and release notes. Click “Next.”

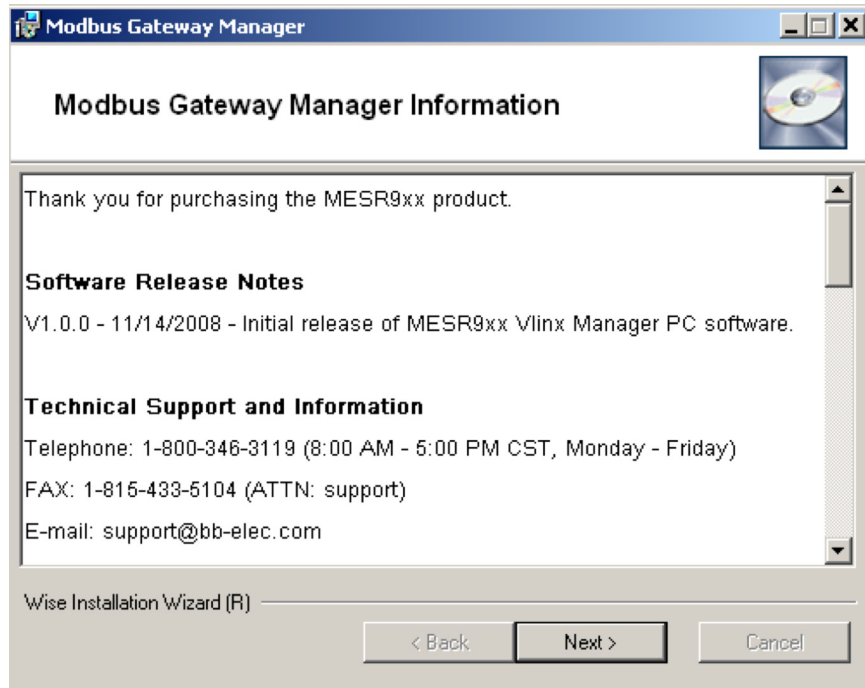

Figure 22. Information Screen

- h. Click “Next.” The Installation Complete screen will be displayed on your computer. Click “Finish” to finish the installation.



Figure 23. Installation Complete Screen

## Configuring the MESR901 Modbus Gateway via the Network Connection

When configuring via the network, either Modbus Configuration software or the web interface can be used.

### Configuring with Modbus Configuration Manager

MESR901 Modbus Gateways can be configured over the network Modbus Configuration manager software running on a PC.

To open Modbus Configuration Manager:

1. From the Desktop, click Start → Programs → B&B Electronics → Vlinx → Modbus Gateway Manager. An alternate method is to double click the shortcut installed on the desktop.

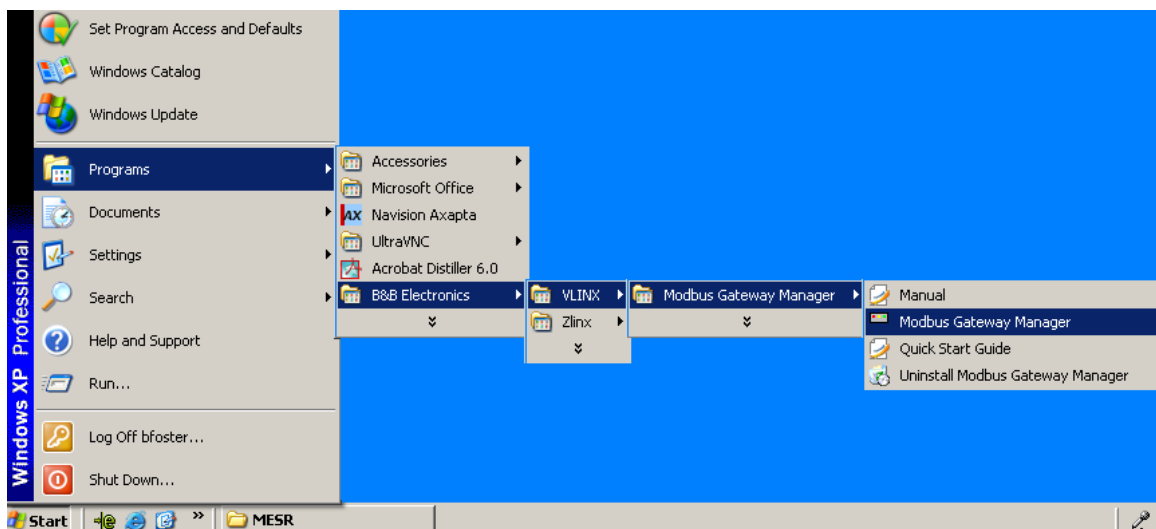

Figure 24. Opening Vlinx Modbus Gateway Manager

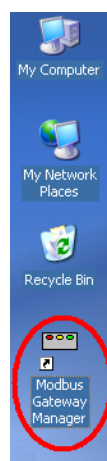

Figure 25. Vlinx Modbus Gateway Manager Shortcut Icon

- The Vlinx Modbus Configuration Manager Device Discovery window appears.

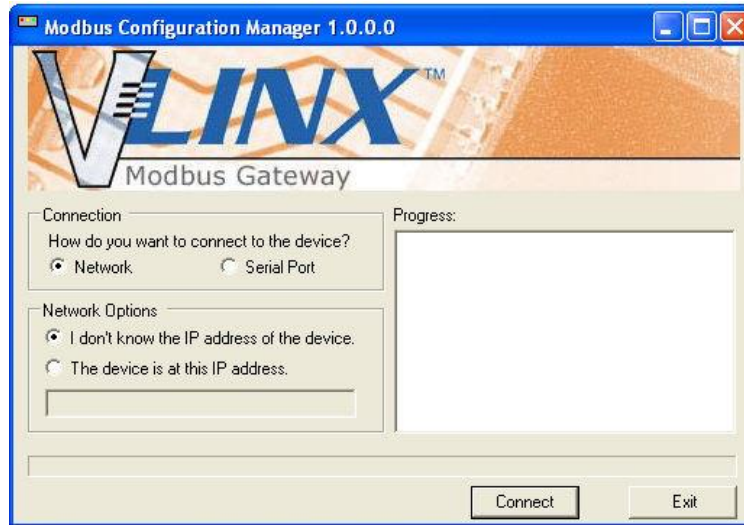

Figure 26. Vlinx Modbus Configuration Manager Discovery Window

- If you do not know the IP address, check the “Network” and “I don’t know the IP address of this device” selections and press the “Connect Button.” The software will discover any MESR901 Gateways on the network. The configuration manager screen will be displayed on your computer. All available devices will be listed on the top portion of this screen. If you know the IP address, you may select “The Device is located at this IP address” and input the address in the box provided.

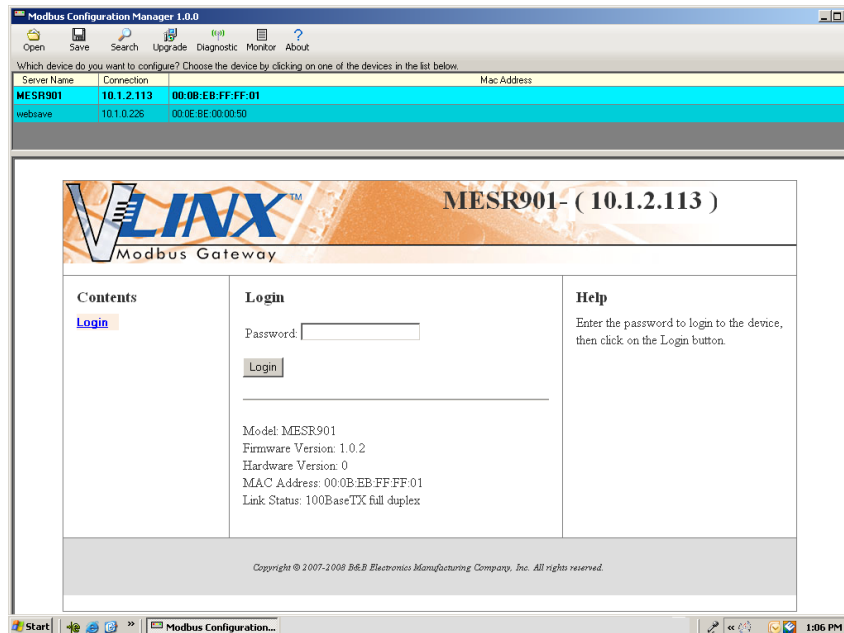

Figure 27. Configuration Manager Screen

4. All Modbus Gateways on the network will be displayed in the top portion of the screen. To select a gateway, simply click the appropriate device on the top portion of the screen.
  - a. The main portion of the screen displays the Model, Firmware version, Hardware Version, MAC Address, and Link Status. The IP Address is also displayed on the top portion of the screen and title graphic area.
5. The default password is no password. Click the “Login” button. The “General” Settings screen will be displayed on your computer.
6. Vlinx Modbus Manager Settings Screen Overview

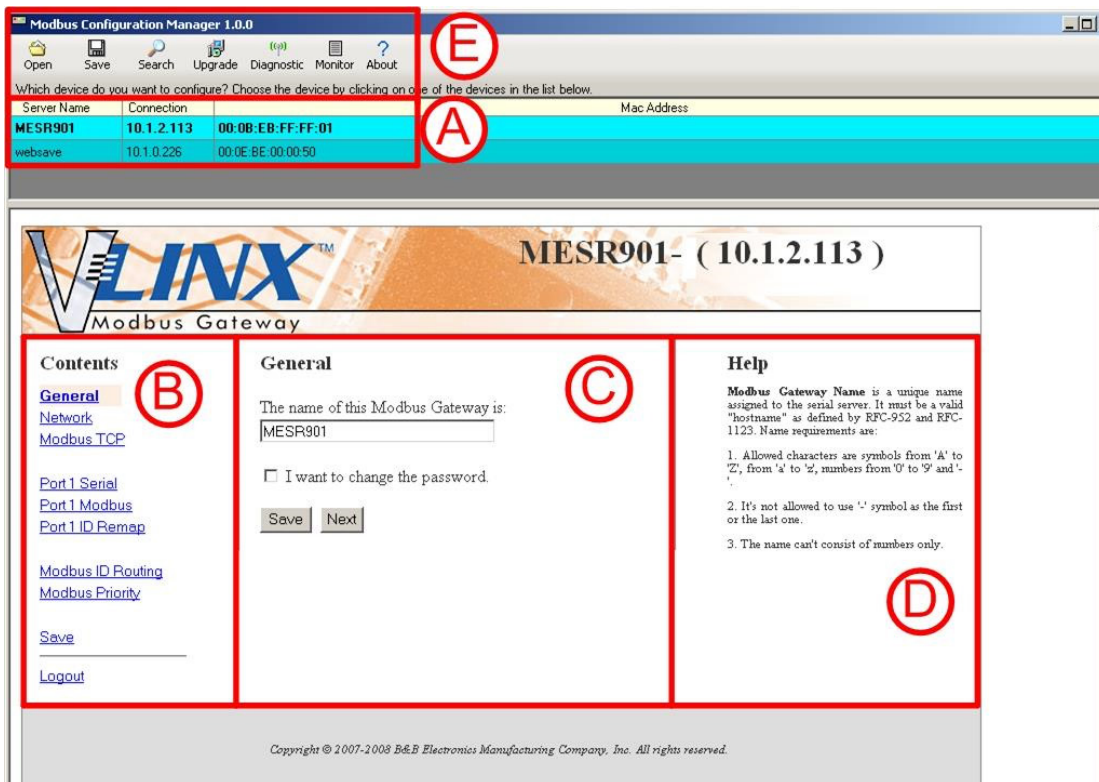

Figure 28. Settings Screen Overview

- a. This area shows Modbus Gateways available on the network.
- b. This area is used to skip directly to the specific configuration screen you need to access. An alternate method of accessing the configuration screens is to use the “Next” button in area C.
- c. This area contains dialog boxes specific the configuration screen.

**1. Note: Any configuration changes you make need to be saved using the “Save” button.**



- d. This area contains helpful information about the configuration screen you are currently on.
- e. This area contains shortcuts to specific functions.
  1. Open allows you to load a previously saved configuration file into your Modbus Gateway.
  2. Save allows you to save your configuration to a file. This should not be confused with the “Save” button described in 6.c above.
  3. Search allows you to search for Modbus Gateways on the network.
  4. Upgrade allows you to upgrade your Modbus Gateway’s firmware.
  5. Diagnostic allows you to test a configured Modbus Gateway. See Section 5.
  6. Monitor allows you to monitor a Modbus Gateway. See Section 5.
  7. About contains information about your Modbus Gateway.

## 7. General Settings

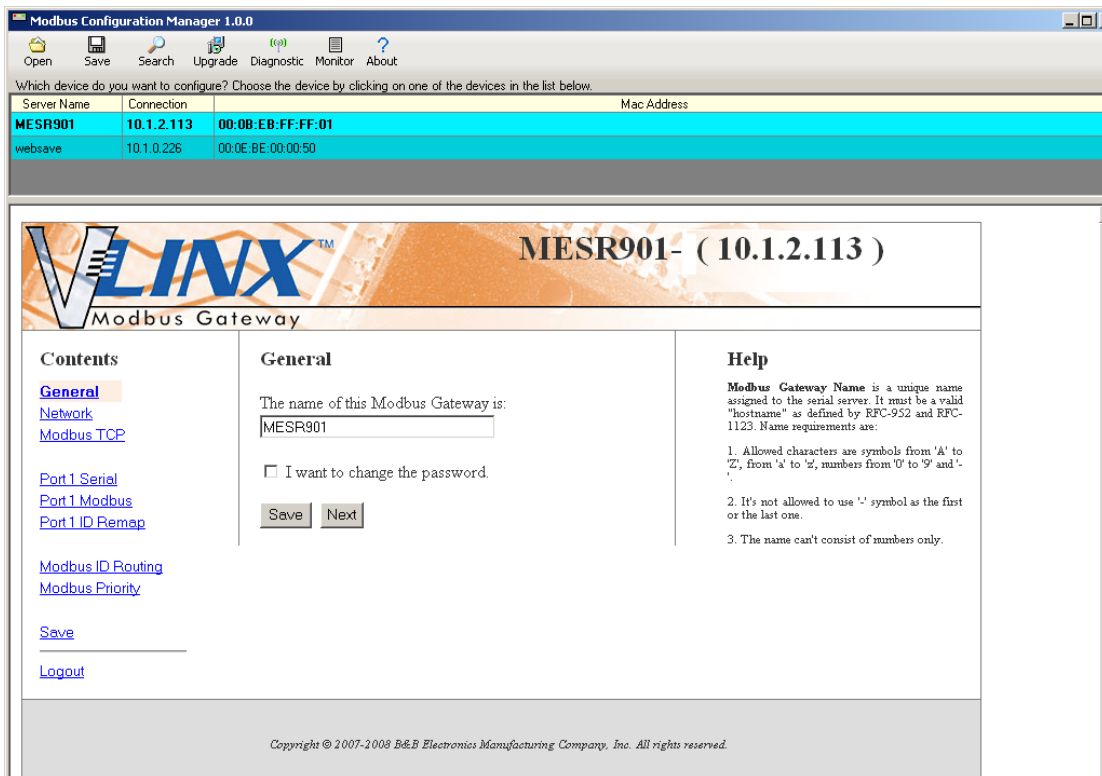

Figure 29. General Settings Screen

- a. This screen enables you to assign a unique name to the gateway. This allows you to easily identify a particular gateway when multiple devices are used on the same network. To change the name, type a new name in the “The Name of this Modbus Gateway is” box. The name must be a valid "hostname" as defined by RFC-952 and RFC-1123. Allowed characters are A to Z, a to z, 0 to 9 and “-“. The “-“ symbol cannot be the first or last character. The name cannot consist of numbers only. **To save the new name click the “Save” button.**
- b. You can also change the gateway’s password on this screen. To do this, check the “I want to change the password” box. New password entry boxes will appear on the screen.

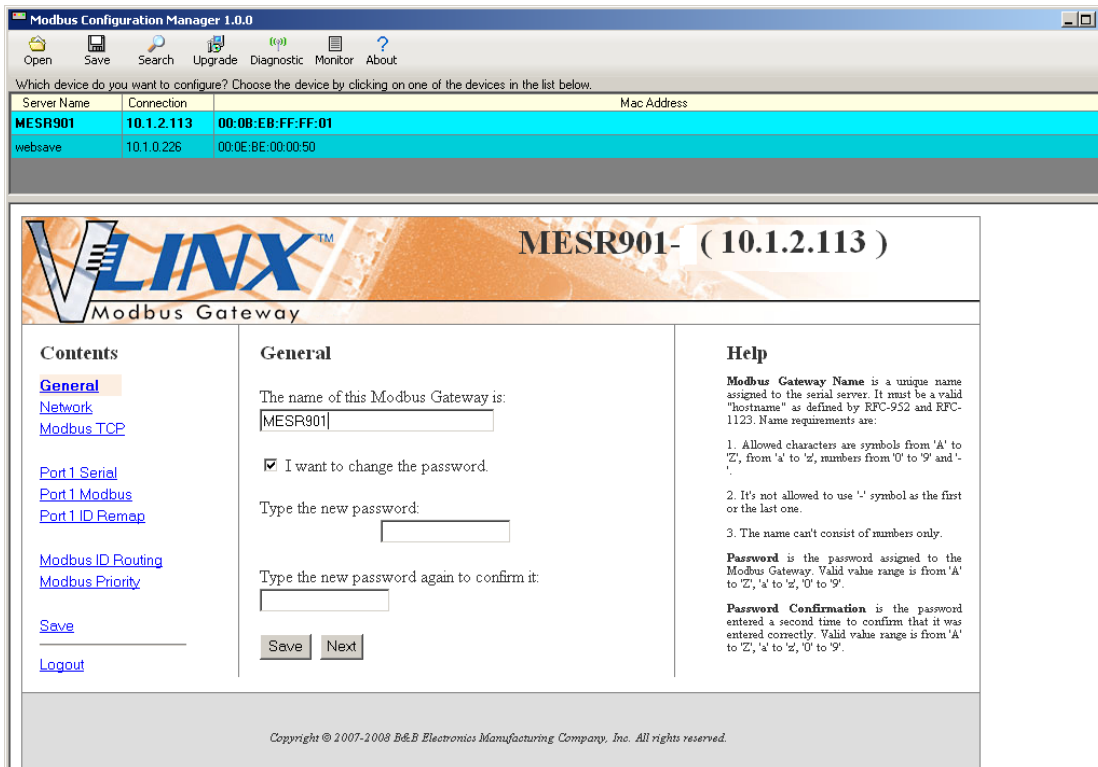

Figure 30. Changing The Password

- c. Type your new password in the “Type the new password box.” Verify the password by typing it again in the box provided. **To save the new password click the “Save” button.**

## 8. Network Settings

- a. To get to the Network Settings Screen you can either click the “Next Button” or click on the “Network” link on the left side of the screen.



Figure 31. Network Settings Screen (DHCP Selected)

- b. The default network configuration is to receive an IP address assignment from a DHCP server. **DHCP** controls whether or not a DHCP server is used to set the IP address, subnet mask and default gateway of the Modbus Gateway. When DHCP option is enabled but the DHCP server is not found, the Modbus Gateway will automatically configure IP address 1169.254.255.255 with a subnet mask 255.255.0.0
- c. To configure your Modbus Gateway without using a DHCP Server, uncheck the “I want DHCP to setup the network” box. You will need to know the IP Address, Subnet Mask, and Default Gateway.

**IP Address** field contains static internet protocol address of the Modbus Gateway.

**Subnet Mask** field contains mask that is used to define sub network.

For Class A network (IP addresses 0.0.0.0 through 127.255.255.255), the default subnet mask is 255.0.0.0.

For Class B network (IP addresses 128.0.0.0 through 191.255.255.255), the default subnet mask is 255.255.0.0.

For Class C network (IP addresses 192.0.0.0 through 223.255.255.255), the default subnet mask is 255.255.255.0.

For Class D network (IP addresses 224.0.0.0 through 239.255.255.255) and Class E network (IP addresses 240.0.0.0 through 255.255.255.255), the subnet mask is ignored.

**Default Gateway** field contains default route to remote networks.

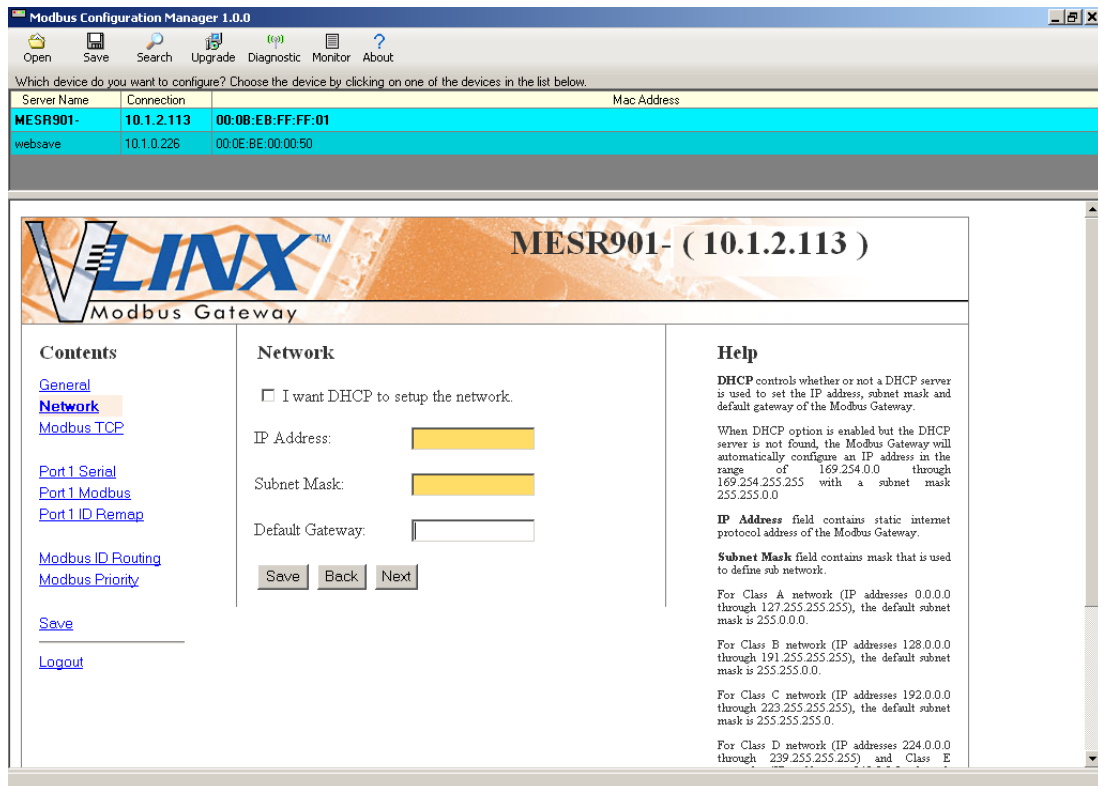

Figure 32. Network Settings Screen (DHCP not Selected)

d. More information about assigning an IP address without using a DHCP Server is contained in the section [Configuring the VESR90x Serial Server on Networks without a DHCP Server](#).

e. Save changes by Clicking the “Save” button.

### 9. Modbus TCP Settings

a. To access this screen, click the “Next Button” or click on the Modbus TCP link on the left side of the screen.

b. This screen allows you Modbus TCP client and server settings.

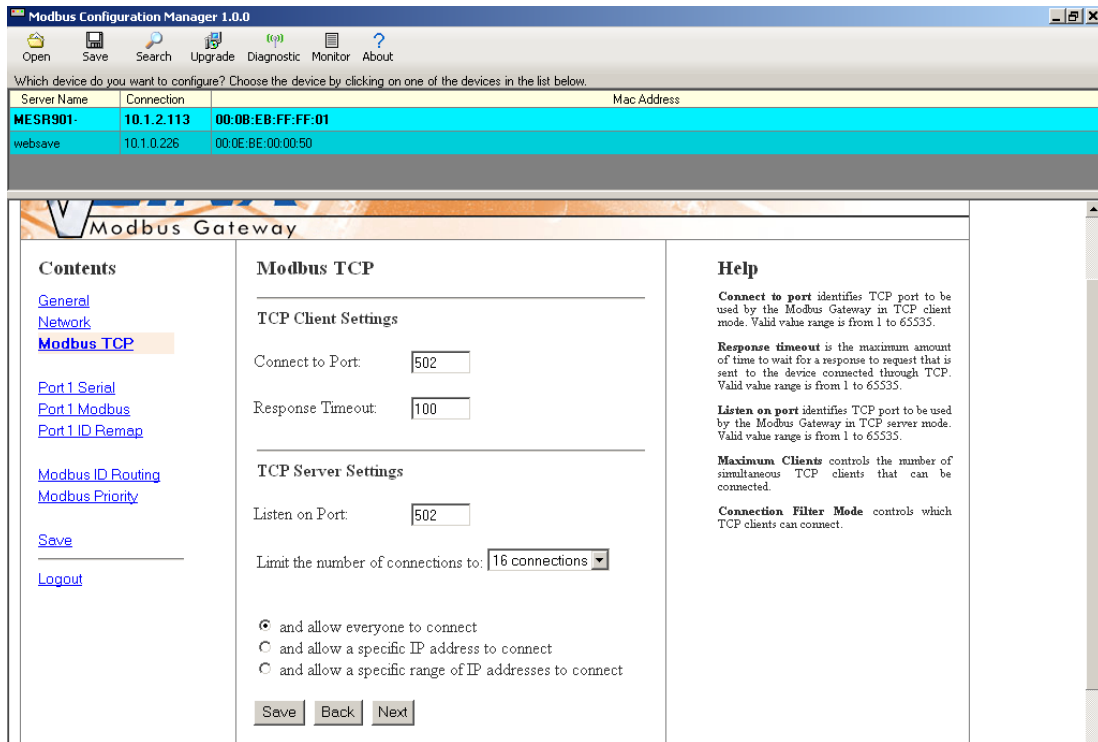

Figure 33. Modbus TCP Settings Screen

#### c. TCP Client Settings

1. Connect to Port identifies TCP port to be used by the Modbus Gateway in TCP client mode. Valid value range is from 1 to 65535.
2. Response Timeout is the maximum amount of time to wait for a response to a request that is sent to the device connected through TCP. Valid value range is from 1 to 65535.
3. Save settings by clicking the “Save” button.

#### b. TCP Server Settings

1. Listen on Port identifies TCP port to be used by the Modbus Gateway in TCP server mode. Valid value range is from 1 to 65535.
2. “Limit the number of connections to” pull down box allows you to control the number of simultaneous TCP clients that can be connected. Choices are 1 through 16.
3. Connection Filter Mode controls which TCP clients are able to connect. The default is: “and allow everyone to connect.”

- a. You can select “allow specific IP addresses to connect.”  
This filter is limited to 4 IP addresses.

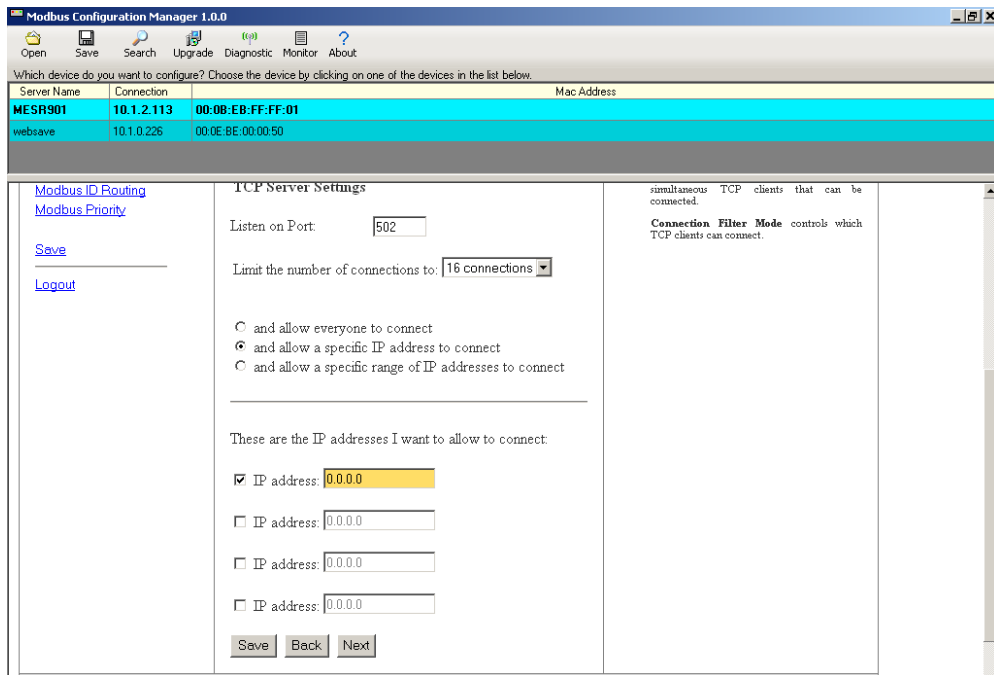

Figure 34. TCP Connection Filter “Allow Specific IP addresses to Connect

- b. You can select “a specific range of IP addresses to connect.”  
This filter is limited to 4 IP address ranges.
- c. Save settings by clicking the “Save” button.

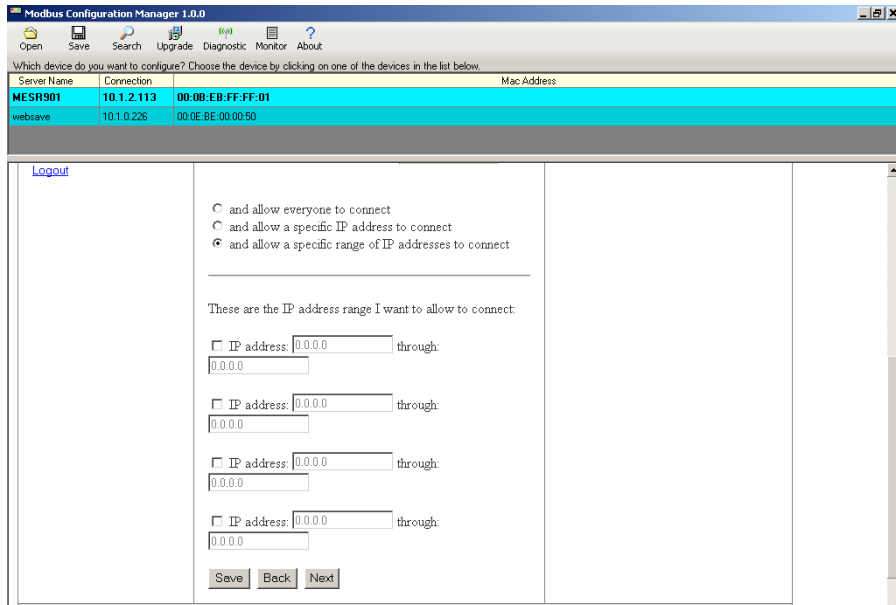

Figure 35. TCP Connection Filter “Allow Specific Range of IP Addresses to Connect

## 10. PORT x Serial Settings

- To access this screen, click the “Next” button or click the Port X Serial link on the left side of the screen. X = The Serial Port number (1 or 2).
- This screen allows you to change the serial port settings.

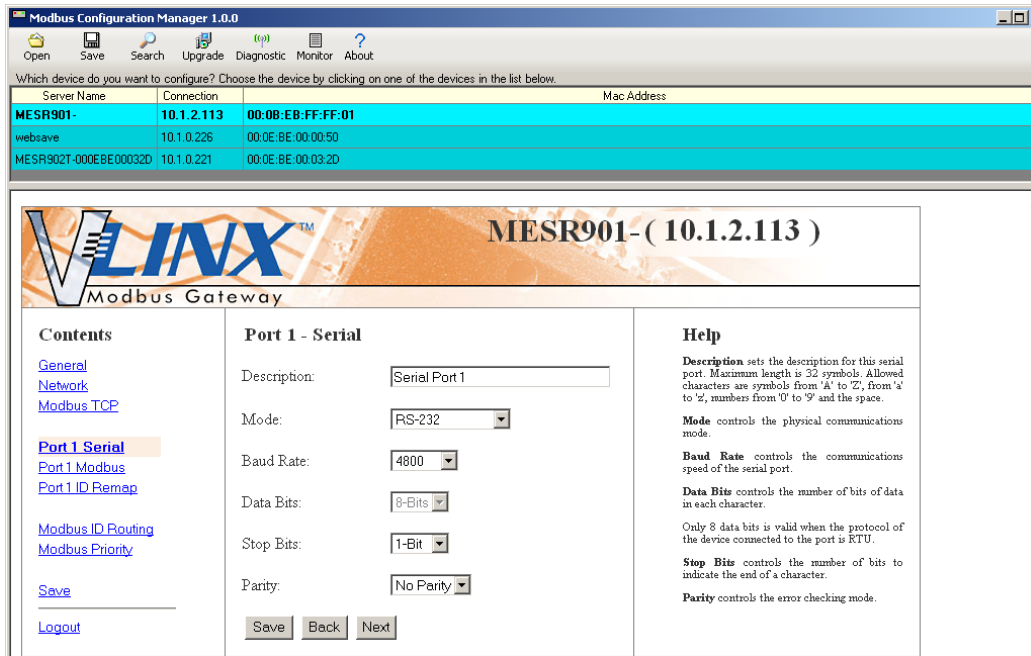

Figure 36. Serial Port Screen

- Description - sets the description for this serial port. Maximum length is 32 symbols. Allowed characters are symbols from 'A' to 'Z', from 'a' to 'z', numbers from '0' to '9' and the space.
- Mode – Controls the physical communications mode for the. The Mode can be RS-232, RS-422 (4-Wire), RS-485 (2-Wire), or RS-485 (4-Wire).
- Baud Rate – Controls the communications speed of the serial port. The Baud Rate can be 2400, 7200, 9600, 14400, 19200, 14400, 28800, 38400, 57600, 115200, or 230400.
- Stop Bits – Controls the number of bits to end a character. Choices are 1 or 2.
- Parity – Controls the error checking mode. Choices are Odd, Even, Mark, or Space.
- Save settings by clicking the “Save” button.

## 11. Port X Modbus

- a. To access this screen, click the “Next” button or click the “Port X Modbus” Link on the left side of the screen. X = The Serial Port Number (1 or 2).
- b. This screen allows you to change the Modbus settings for the port.

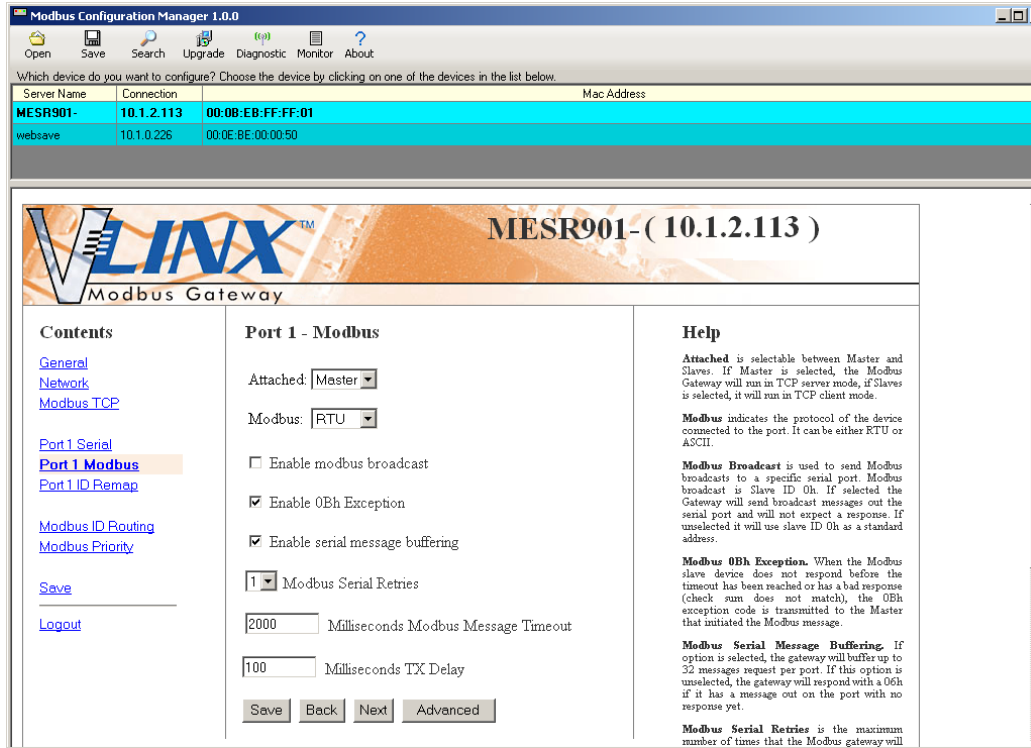

Figure 37. Modbus Port Screen

- c. Attached – This is selectable between Master and Slaves. If Master is selected, the Modbus Gateway will run in TCP server mode, if Slaves is selected, it will run in TCP client mode.
- d. Modbus – indicates the protocol of the device connected to the port. It can be either RTU or ASCII.
- e. Modbus Broadcast – Check this box to send Modbus broadcasts to a specific serial port. Modbus broadcast is Slave ID 0h. If selected the Gateway will send broadcast messages out the serial port and will not expect a response. If unselected it will use slave ID 0h as a standard address.
- f. Enable 0Bh Exception – Check this box to enable. When the Modbus slave device does not respond before the timeout has been reached or has a bad response (check sum does not match), the 0Bh exception code is transmitted to the Master that initiated the Modbus message.
- g. Enable Serial Message Buffering – If this option is selected, the gateway will buffer up to 32 messages request per port. If this option is unselected, the gateway will respond with a 06h if it has a message out on the port with no response yet.



- h. Modbus Serial Retires – Select 0 through 5. This sets the maximum number of times that the Modbus gateway will retry to send a Modbus message to a Modbus client, before reporting a 0Bh exception if it is selected. Number of retries is limited to 5.
- i. Milliseconds Modbus Message Timeout – This is the maximum amount of time to wait for a response to the message. Valid value range is from 1 to 65535.
- j. Milliseconds TX Delay – This is the minimum amount of time after receiving a response before the next message can be sent out. Valid value range is from 1 to 65535.
- k. Save settings by clicking the “Save” button.

## 12. Port x ID Remap

- a. To access this screen, click the “Next” button or click the “Port x ID Remap” link on the left side of the screen.
- b. This screen allows you to set Modbus Slave ID Remap settings.

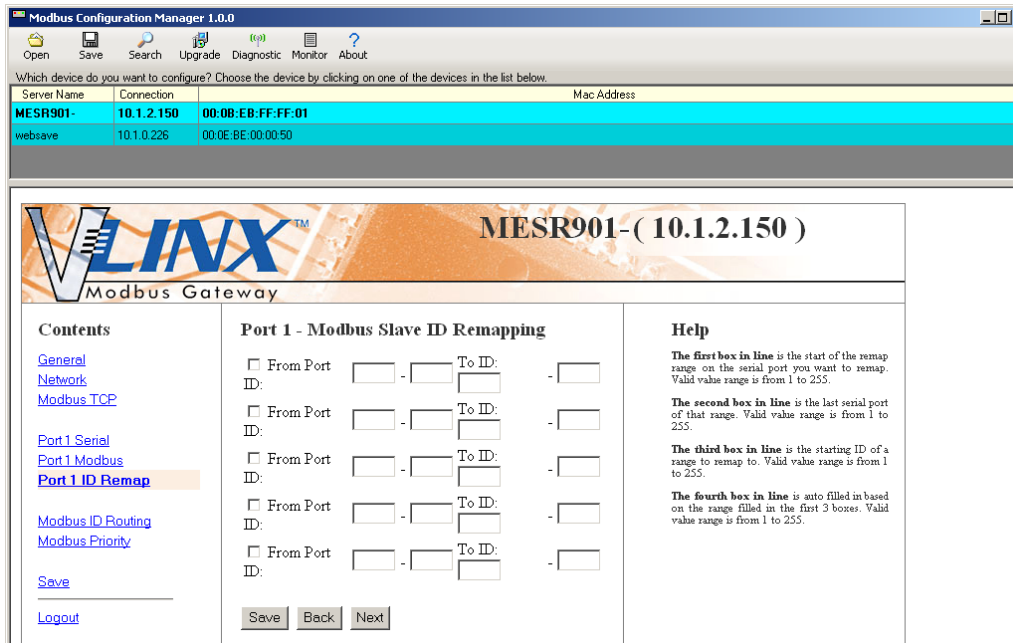

Figure 38. Port ID Remap Screen

- c. The first box in line is the start of the remap range on the serial port you want to remap. Valid value range is from 1 to 255.
- d. The second box in line is the last serial port of that range. Valid value range is from 1 to 255.

- e. The third box in line is the starting ID of a range to remap to. Valid value range is from 1 to 255.
- f. The fourth box in line is auto filled in based on the range filled in the first 3 boxes. Valid value range is from 1 to 255.
- g. Save settings by clicking the “Save” button.

### 13. Modbus ID Routing

- a. To access this screen click the “Next” button or click the “Modbus ID Routing” Link on the left side of the screen.
- b. This screen allows you to set the Modbus Slave ID routing.

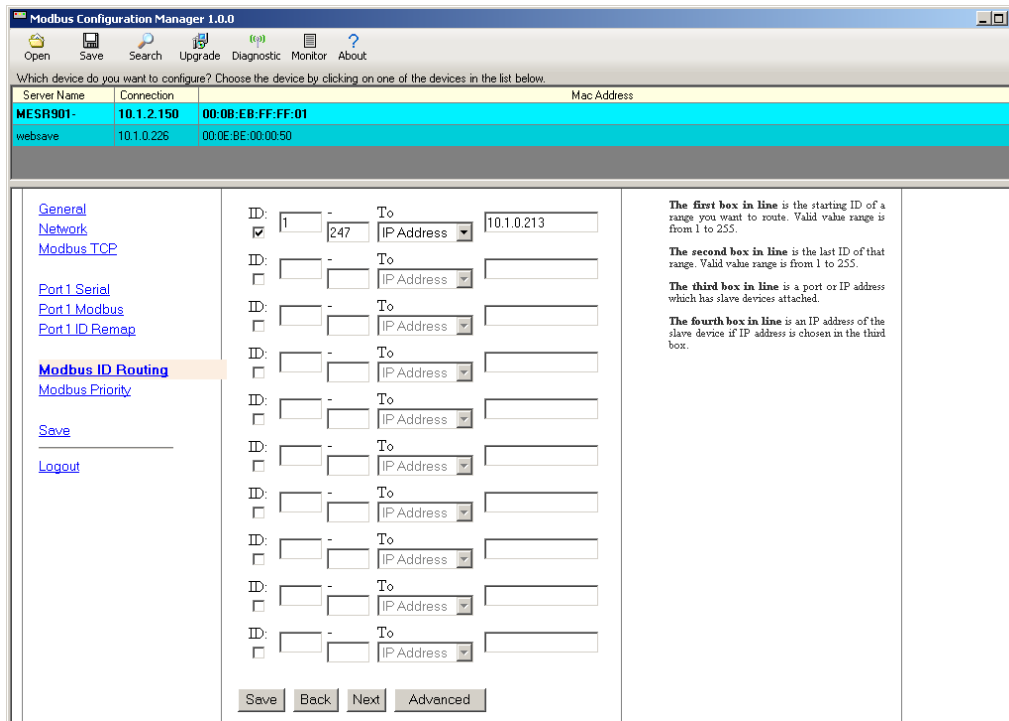

Figure 39. Modbus ID Routing Screen

- c. The first box in line is the starting ID of a range you want to route. Valid value range is from 1 to 255.
- d. The second box in line is the last ID of that range. Valid value range is from 1 to 255.
- e. The third box in line is a port or IP address which has slave devices attached.
- f. The fourth box in line is an IP address of the slave device if IP address is chosen in the third box.
- g. Save settings by clicking the “Save” button.

### 14. Modbus Priority

- a. To access this screen, click the “Next” button or click the “Modbus Priority” link on the left side of the screen.
- b. This screen allows you to configure the gateway to move high priority messages to the front of the serial message buffer.

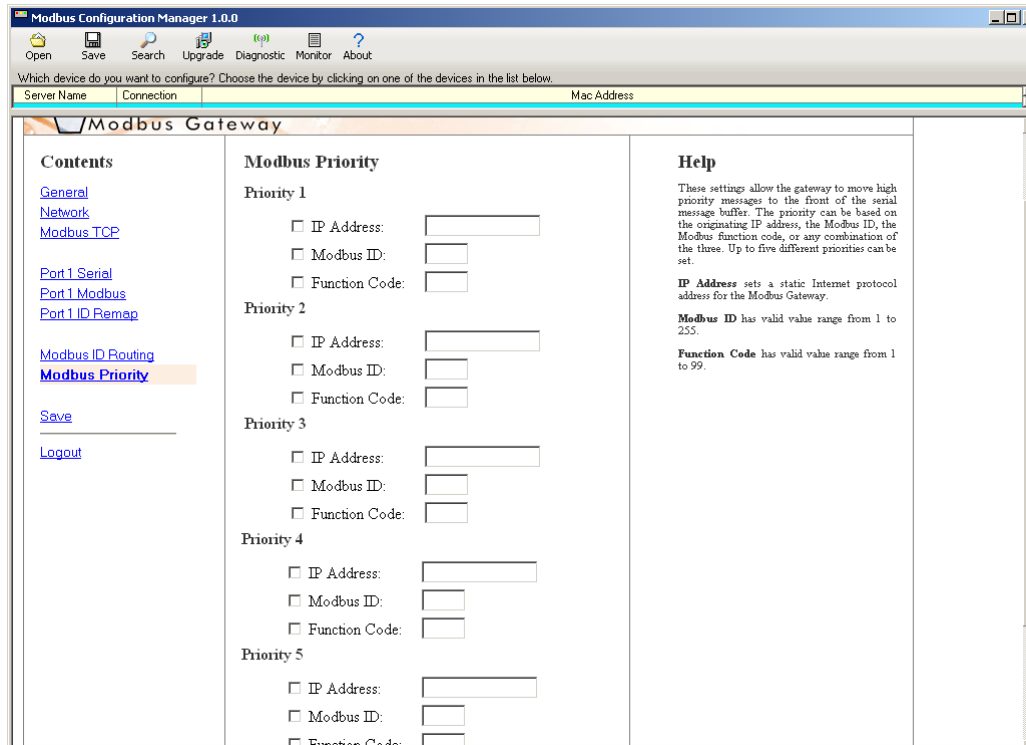

Figure 40. Modbus Priority Screen

- c. These settings allow the gateway to move high priority messages to the front of the serial message buffer. The priority can be based on the originating IP address, the Modbus ID, the Modbus function code, or any combination of the three. Up to five different priorities can be set.
- d. IP Address – Used to set a static Internet protocol address for the Modbus Gateway.
- e. Modbus ID – Valid range is from 1 to 255.
- f. Function Code – Valid range is from 1 to 99.
- g. Save settings by clicking the “Save” button.

Note: For more information on configuration options refer to Section 4: Description of Modbus gateway Properties.

### Configuring with the Web Interface

MESR901 Modbus Gateways can be configured over the network using a standard internet browser such as Internet Explorer or Firefox.

To open the web configuration interface:

1. On a PC connected to the network, open a web browser.

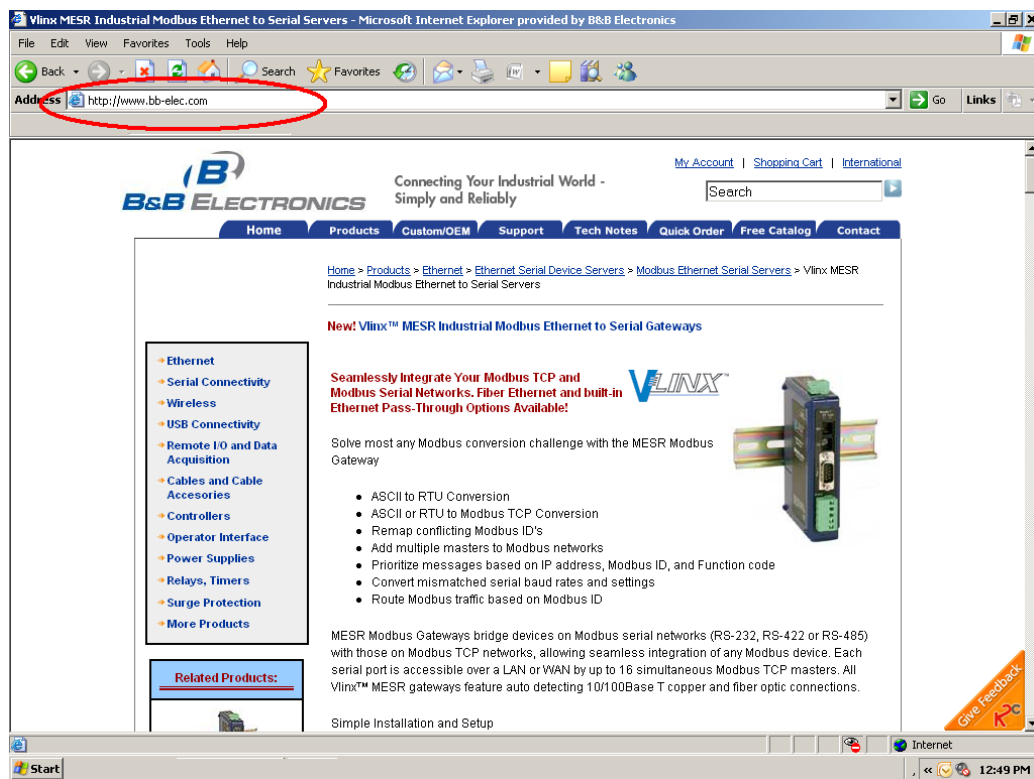

Figure 41. Open Web Browser

2. In the browser's address bar, type the IP address of the Modbus gateway.

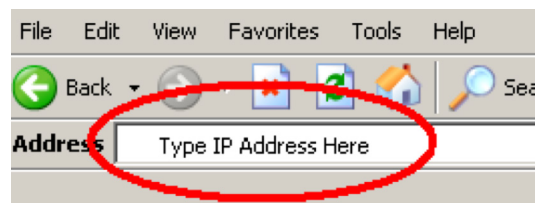

Figure 42. Type IP Address

Note: Your Modbus gateway comes from the factory pre-configured to receive an IP address assignment from a DHCP server. If a DHCP Server is not available on your network, it will default to 169.254.102.39.

The web interface Login page appears.

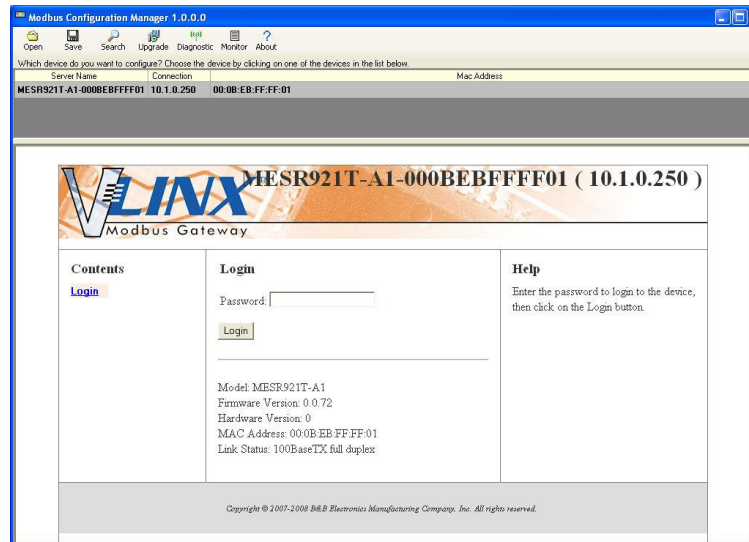

Figure 43. Modbus Gateway Login Screen

3. The screens for configuring your gateway using a web browser are the same as those used to configure using the [Vlinx Modbus Manager software](#).

### Configuring the MESR901 Modbus Gateway on Networks without a DHCP Server

Your Modbus Gateway comes from the factory set up to receive an IP assignment from a DHCP Server. If there is not a DHCP server on your network, the Modbus Gateway will default to IP address **169.254.102.39**. If this address does not work with your PC, there are two methods to manually configure the network information.

1. Method 1: Change your PC Network to Match the Modbus Gateway
  - a. Open your network connection

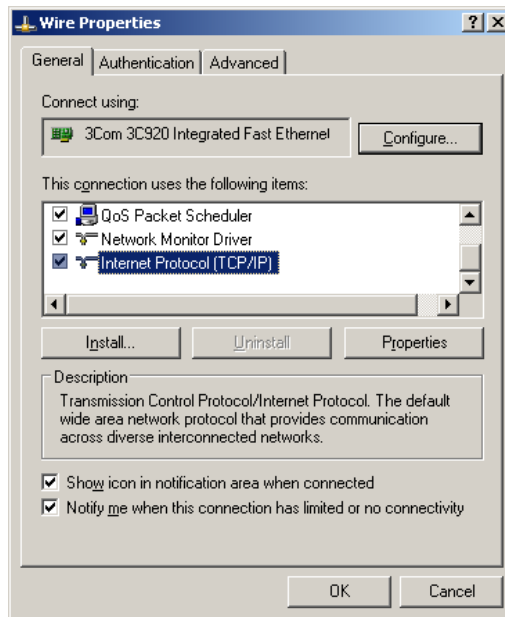

- b. Click on Internet Protocol (TCP/IP) and click <properties>. Change the parameters to the following:

IP Address = 169.254.102.1

Subnet Mask = 255.255.0.0

Default Gateway = 169.254.102.100

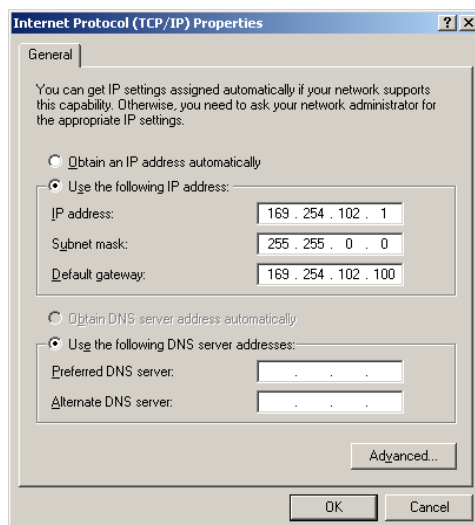

- c. Use the Vlinx™ Modbus Manager Software to search for, discover, and configure the Modbus Gateway.

## 2. Method 2: Change the Modbus Gateway's network settings to match your PC using Console Mode

- a. Connect a null modem serial cable (crossover cable) from port 1 on the Modbus Gateway to an available COM port on your PC.
- b. Open Hyper Terminal or similar serial emulation software and connect to the COM port used in step one. Ensure the port is configured to 115,200 baud, 8 data bits, no parity, and 1 stop bit.
- c. Enter Console Mode. Press and hold the Modbus Gateway's for 2 to 10 seconds. The LED indicators will respond as follows:

Model	Port 1 LED	Port 2 LED	Ready LED
MESR9x1	OFF	XXXXXXXX	ON
MESR9x2	OFF	ON	OFF

- d. Release the reset button. The READY LED will blink once per second for five seconds. This indicates that the Modbus Gateway is re-booting in Console Mode.
- e. When the Modbus Gateway has successfully restarted in Console Mode, the READY LED will be OFF and the PORT 1 LED will be ON.
- f. Open the Vlinx™ Modbus Manager Software and select “Serial Port” as the method to connect to the Modbus Gateway.
- g. After logging in, click on <Network>.
- h. Un-check the box next to “I Want DHCP to setup the Network.”
- i. Re-configure the Modbus Gateway's network settings to something within the range of your PC's network settings. For example:

### PC Network Settings

IP Address = 192.168.0.1

Subnet Mask = 255.255.0.0

Default Gateway = 192.168.0.100

### Change the Modbus Gateway's network settings to:

IP Address = 192.168.0.50

Subnet Mask = 255.255.0.0

Default Gateway = 192.168.0.100

- j. Save the settings and remove power from the Modbus Gateway.
- k. Re-apply power. Open the Vlinx™ Modbus Manager Software and select “Network” as the method to connect to the device.

### **Configuring the MESR901 Modbus Gateway via the Serial Port (Console Mode)**

Your Modbus gateway can be configured via a serial port using Vlinx Modbus Manager. To use this feature the Modbus gateway's serial port must be connected to the serial port of a PC (using a null modem cable).

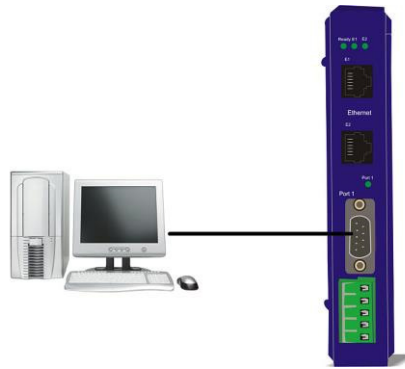

Figure 44. Console Mode Setup

To configure the Modbus gateway it must be put into Console Mode, using the Mode switch.

**To enter Console Mode**, press and hold the Mode switch for between two and ten seconds. The LED indicators respond as follows:

1. The Ready LED blinks three times per second while the button is being pressed.
2. The Modbus gateway is in Console Mode when:
  - On the MESR901: Port 1 LED is On and the Ready LED is Off.

**To configure the Modbus gateway**, open the Vlinx Modbus Manager software and set up the Modbus gateway's parameters as required.

1. Under Connection, select “Serial Port.”



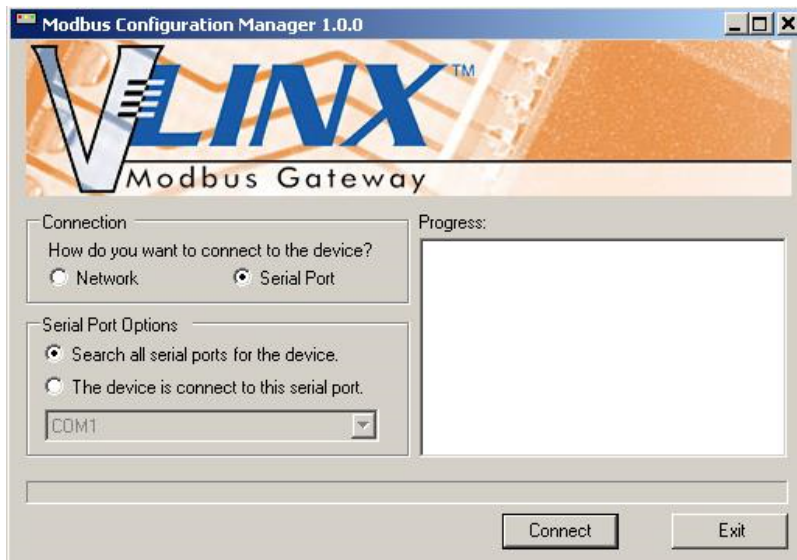

Figure 45. Connection

2. If you do not know which COM port your gateway is connect to, select “Search all serial ports for the device” under Serial Port Options. If you do know, you may specify the COM port by selecting “The device is connected to this serial port” under Serial Port Options and using the pull down menu to choose the COM port.

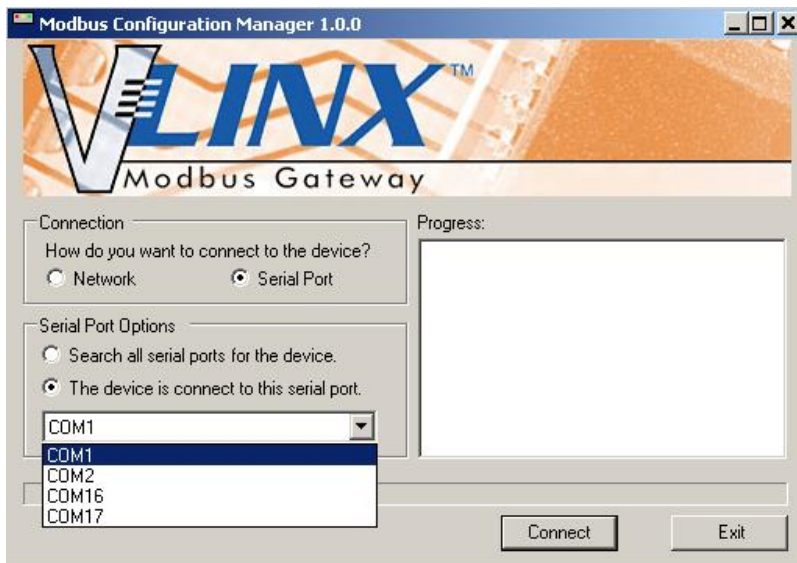

Figure 46. Serial Port Selection

3. The remaining screens are identical to those shown in configuring your gateway using a [network connection](#).

To exit **Console Mode**, press and hold the Reset switch for two seconds.

The LEDs go back to their normal states when the device resumes normal operation.

## MESR901 Modbus Gateway Operational Connections

MESR901 Modbus Gateways can operate in Direct IP Mode.

### Using MESR901 Modbus Gateways in Direct IP Mode

A Direct IP connection allows applications using TCP/IP socket programs to communicate with the COM ports on the Modbus gateway. In this type of application the Modbus gateway is configured as a TCP server. The socket program running on the PC establishes a communication connection with the Modbus gateway. The data is sent directly to and from the serial port on the server.

To set up a Direct IP Mode connection:

1. Connect the Modbus gateway to the network and a Modbus network as described in previous sections.
2. Configure the Modbus gateway with the appropriate network settings (using Vlinx Modbus Manager or the web interface).
3. Configure your software application with the appropriate IP address and port number to communicate with the Modbus network(s).

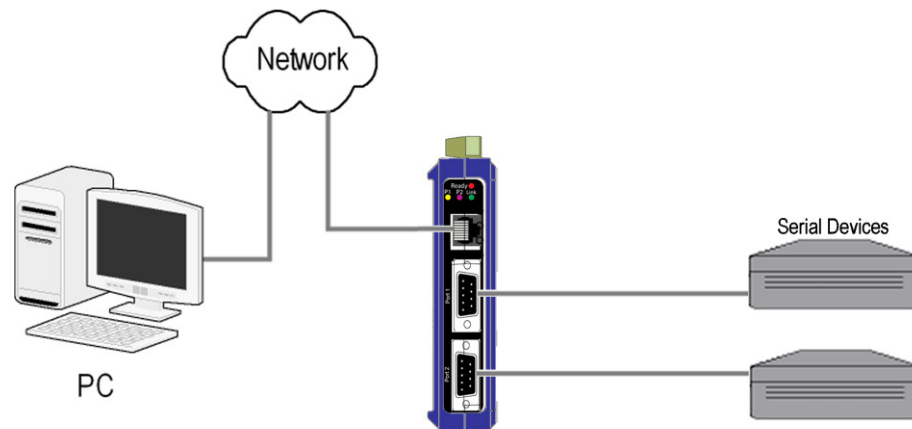

Figure 47. Direct IP Connection

### ***Initiating a Hardware Reset on the Modbus Gateway***

To initiate a **Hardware Reset on the Modbus gateway**, press and hold the Mode switch for 0 to 2 seconds, and then release it. The LED indicators respond as follows:

1. The Ready LED blinks three times per second while the button is being pressed.
2. The Modbus gateway is in Reset Mode when:
  - On the MESR901: Port 1 LED is On and the Ready LED is Off.
3. The LEDs go back to their normal states when the device resumes normal operation.

### ***Reloading Factory Defaults***

To **reload Factory Defaults**, press and hold the Mode switch for more than 10 seconds. The LED indicators respond as follows:

1. The Ready LED blinks three times per second while the button is being pressed.
2. The Modbus gateway is in Factory Default Mode when:
  - On the MESR901: Port 1 LED and the Ready LED are both On.The Modbus gateway reloads all factory default configuration parameters.
3. The LEDs go back to their normal states when the device resumes normal operation.

*Note: Factor default parameters are listed in Appendix A.*

## 4. Upgrading the Modbus Gateway Firmware

Occasionally, updated firmware may become available for your Modbus gateway. The firmware can be upgraded using the Zlinx Manager software. The following procedure describes the firmware updating process:

1. Click the **Upgrade** button to open the **Firmware Upgrade** dialog box.

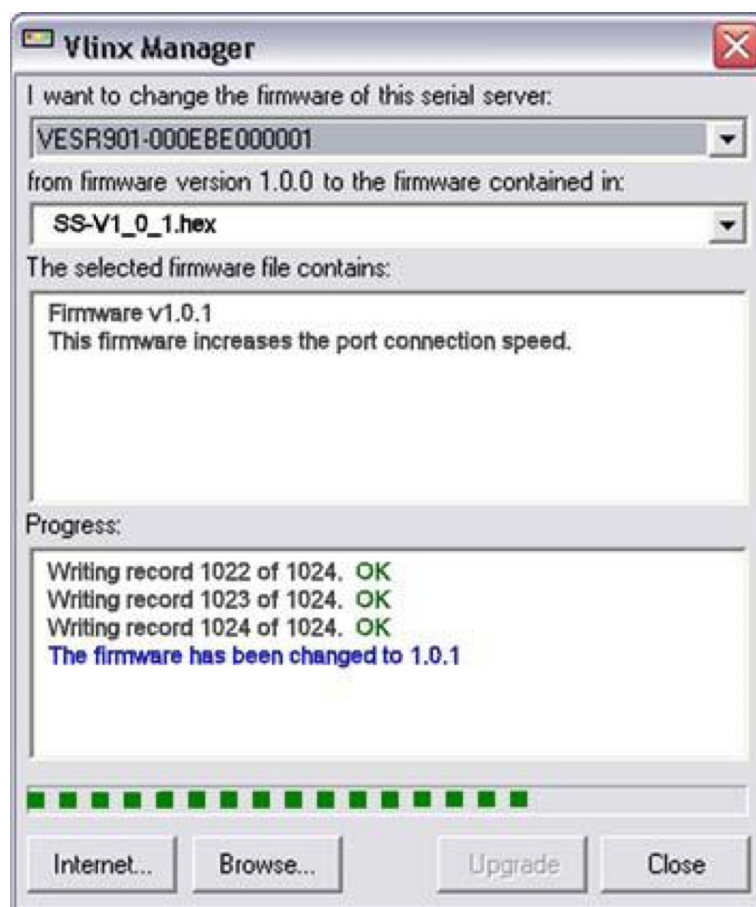

Figure 48. Firmware Upgrade Dialog Box

The name of the currently selected Modbus gateway appears in the top drop down list. Other Modbus gateways (that have already been discovered) can be selected from the drop down list, if desired.

The current firmware version of the selected Modbus gateway is shown in the text below the Modbus gateway name.

Information about the selected firmware file is shown in the third text box.

## Downloading Firmware Files

The **Firmware File** list (second box) displays all firmware files in the firmware installation folder. Only firmware that is compatible with the selected Modbus gateway is available in this list.

### To download the latest firmware files from an FTP site on the Internet:

1. Click the **Internet** button at the bottom of the window.

The Vlinx Modubs Manager connects to an FTP server on the Internet.

2. Click the **Check for Updates** button.

**Progress Bar** and **Progress Box** display information about and progress of the download.

### To download the latest firmware files from a file:

1. Click the **Browse** button to open an **Open File** dialog box.
2. Browse to the drive and folder containing the firmware file.
3. Select and download the file to the local firmware folder.

## Uploading the Firmware to the Modbus Gateway

### To upgrade the firmware:

1. In the **Modbus Gateway Selection** drop down list, select the Modbus gateway to be upgraded.
2. In the **Firmware Description** drop down list, select the firmware to upload to the Modbus gateway.
3. Click the **Upgrade** button.

**Progress Bar** and **Progress Box** provides information on the progress of the transfer.

4. In the **Firmware File** drop down list, select the firmware file to upload to the Modbus gateway.
5. Click **Upgrade**.

The Progress box and Progress bar display information on the upgrading process.

6. When the upgrade process is complete, click **Close**.

## 5. Diagnostics

Clicking the **Diagnostics** icon opens the **Diagnostics** dialog box and enables you to check the operation of connected Modbus gateways on the local computer.

The **Computer Information** box displays information about the type of network connections, the IP addresses, Subnet Masks and Default Gateways in use.

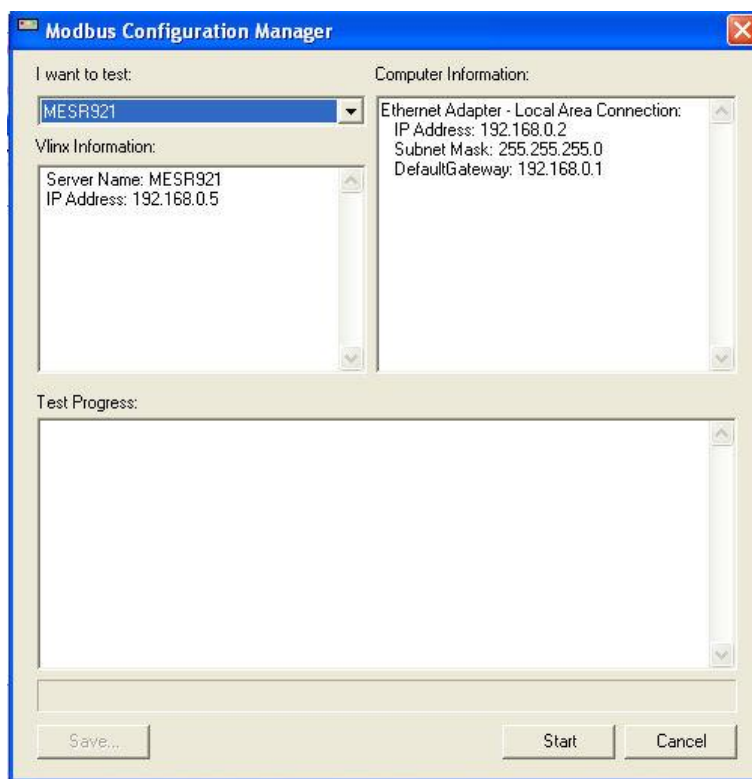

Figure 49. Diagnostics Dialog Box

## Testing a Modbus Gateway Connection

To run diagnostics on a Modbus gateway:

1. Click the **Diagnostics** icon. The **Diagnostics** dialog box appears.
2. In the drop down box select the specific Modbus gateway you want to check.
3. Click the **Start** button

Information about the progress of the pinging process is displayed in the **Test Progress** box.

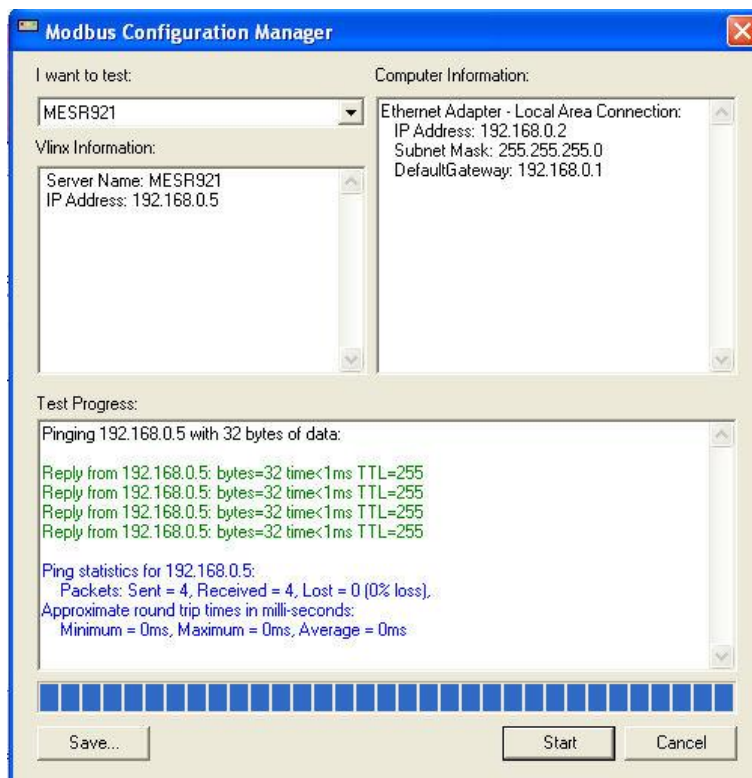

Figure 50. Testing a Modbus Gateway Connection

## **Monitor Function**

The Monitor button is used to display a screen that shows information about events and data transfer through the Modbus Gateway.

To start monitoring, select a Modbus Gateway and press the **“Start”** button.

The **“Auto Scroll”** check box enables and disables automatic scrolling of the displayed text.

The **“Clear”** button clears the displayed text.

Press the **“Stop”** button to stop monitoring.

Press the **“Save”** button to save the information to a file.



## 6. Application Examples

Modbus gateways can be used to integrate Modbus networks in a wide variety of settings. But as each setting has its own requirements, users may not understand how a gateway helps, or if it's appropriate for their specific needs.

The following scenarios are examples only, and many others are possible. Contact B&B Electronics technical support for information on other applications.

### **Ethernet Master and Serial Slaves**

Your Modbus gateway can be used to integrate serial slave devices on a Modbus TCP network. This allows TCP Masters to control serial slave devices. The example below is using a gateway with two serial ports.

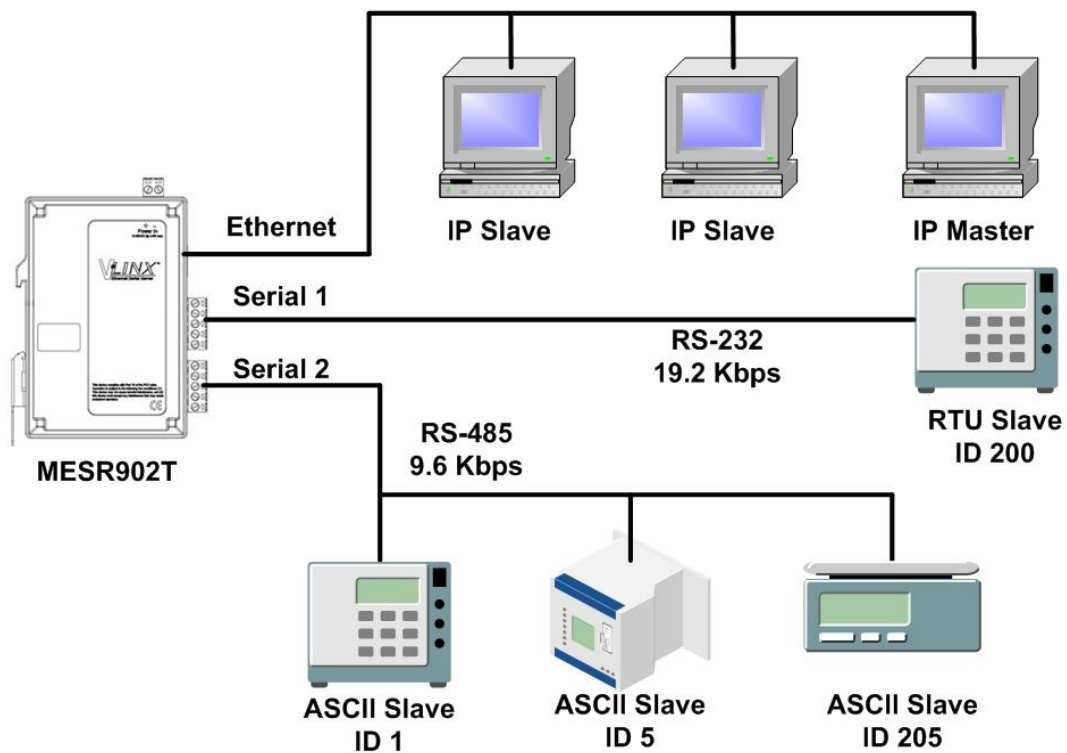

Figure 51. Ethernet Master With Serial Slaves

1. Log into your gateway.
2. Access the serial port one setup screen by clicking the link on the left side of the screen.

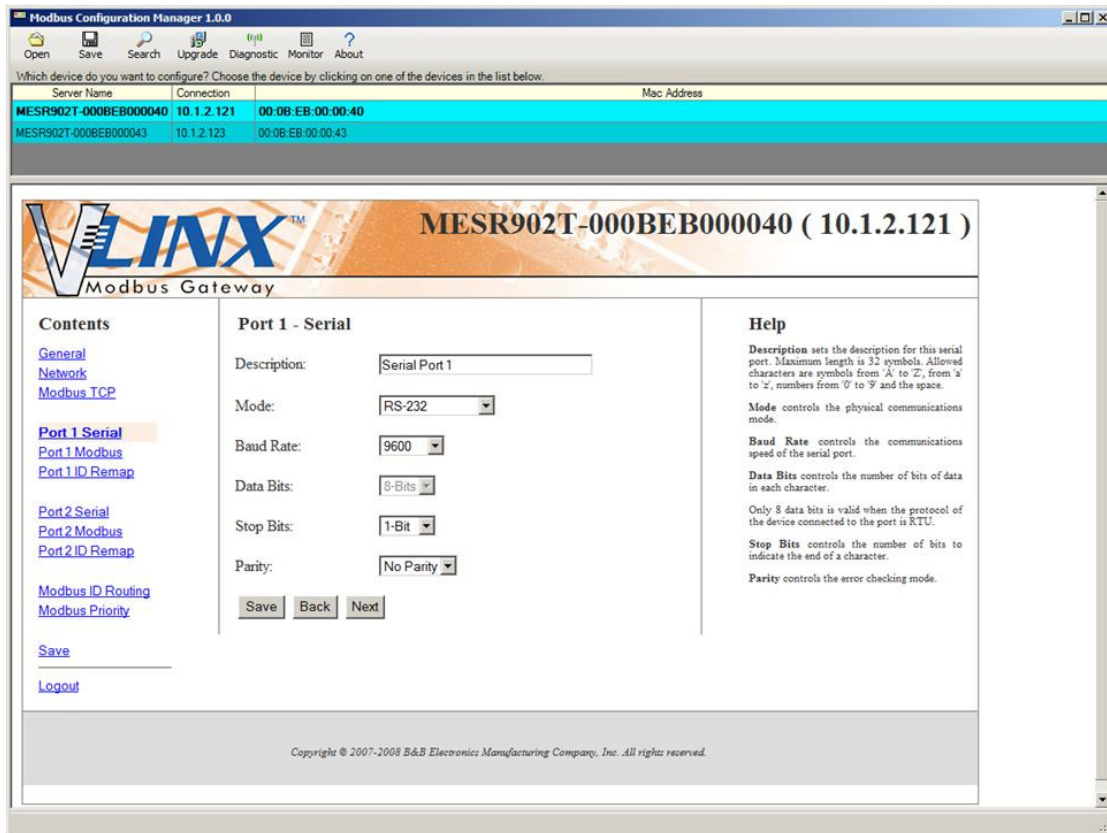

Figure 52. Serial Port 1 Setup

3. Configure Serial Port 1. In this case it is RS-232, 19.2 kbps, 8 data bits, 1 stop bit, and even parity. Save the settings
4. Access Port 1 Modbus by clicking the link on the left side of the screen.

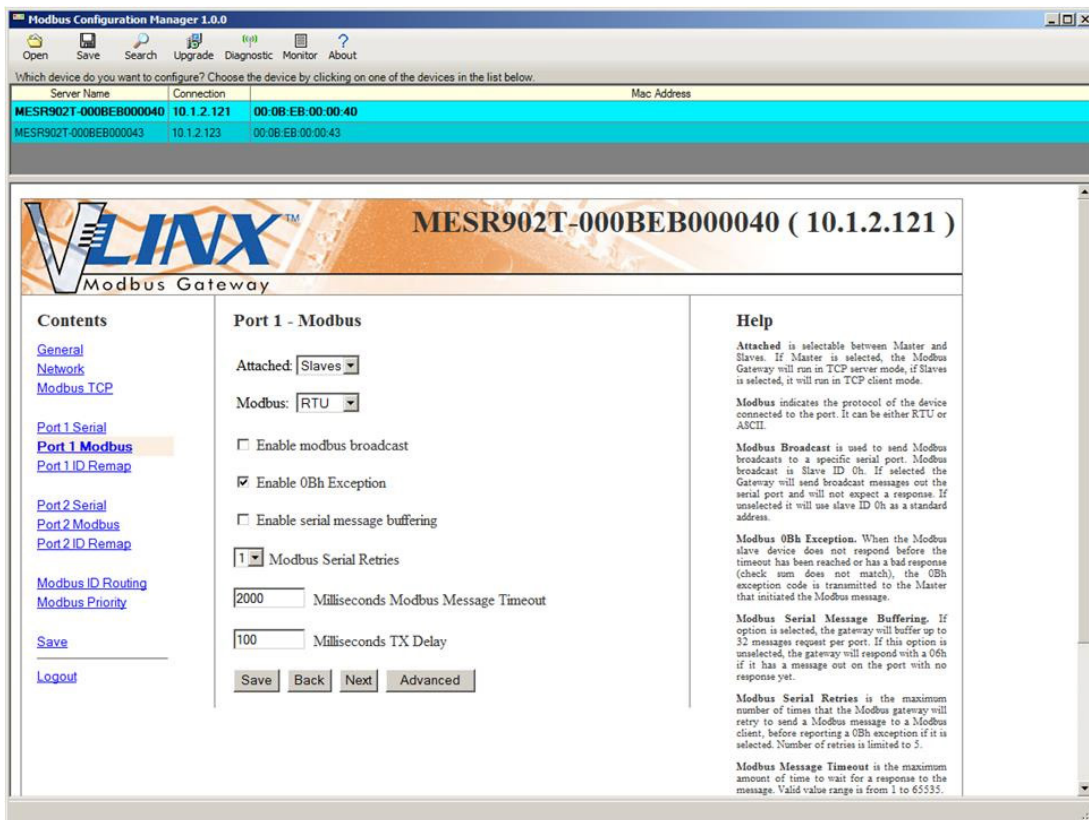

Figure 53. Port 1 Modbus

5. Configure the Port 1 Modbus Settings. In this case Attached should be slaves, Modbus should be RTU. The other settings depend on your application.
6. Configure Port 2 Serial and Modbus is the same fashion.
7. Access Modbus ID Remapping for each port and configure as necessary.

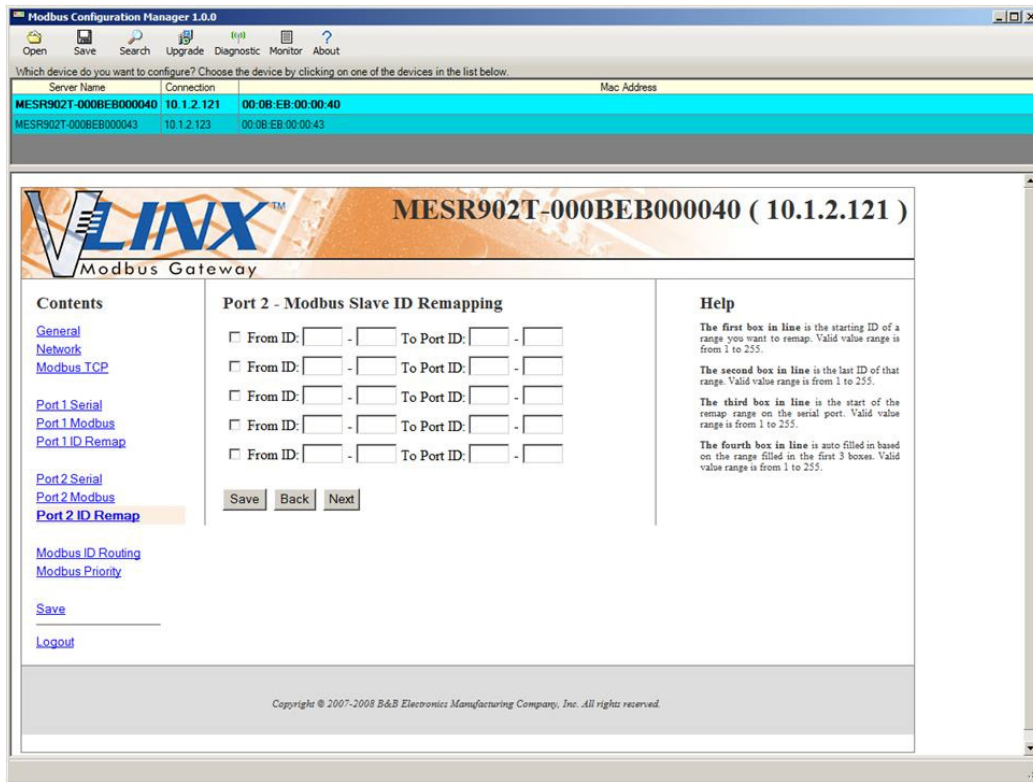

Figure 54. Port x Modbus Slave ID Remapping

8. Access Modbus ID Routing. Configure as necessary. In this example, Slave ID 200 is mapped to serial port 1, Slave ID 1 through 5 and 205 are mapped to serial port 2.

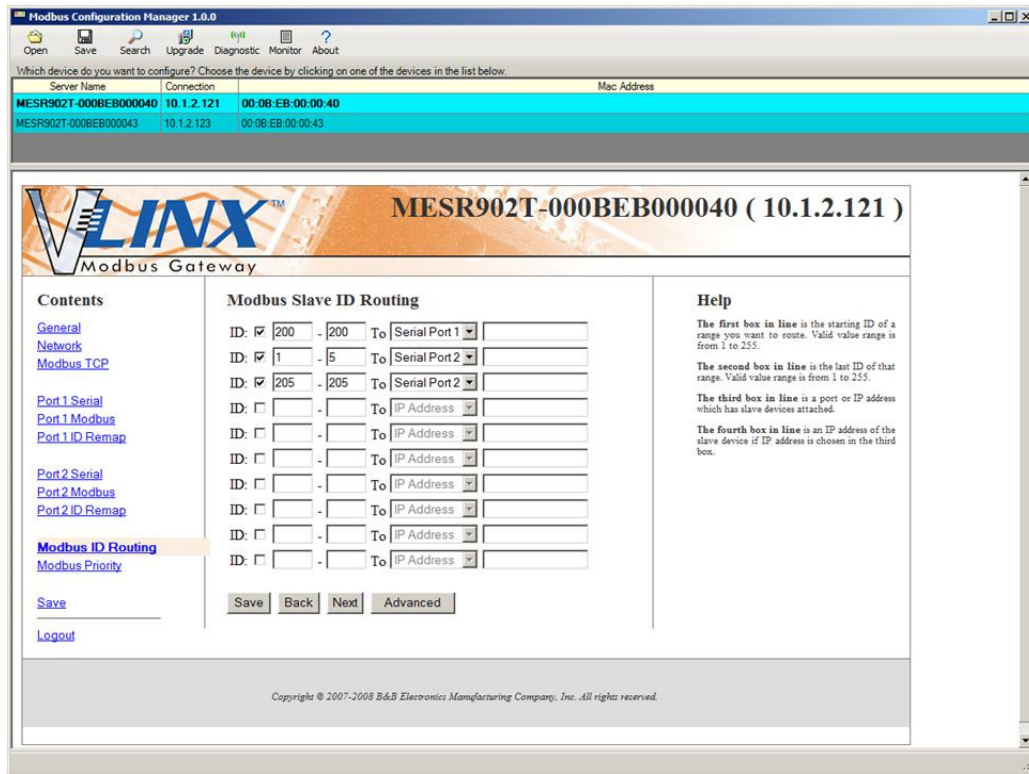

Figure 55. Modbus ID Routing

9. Access Modbus Priority and configure as necessary.

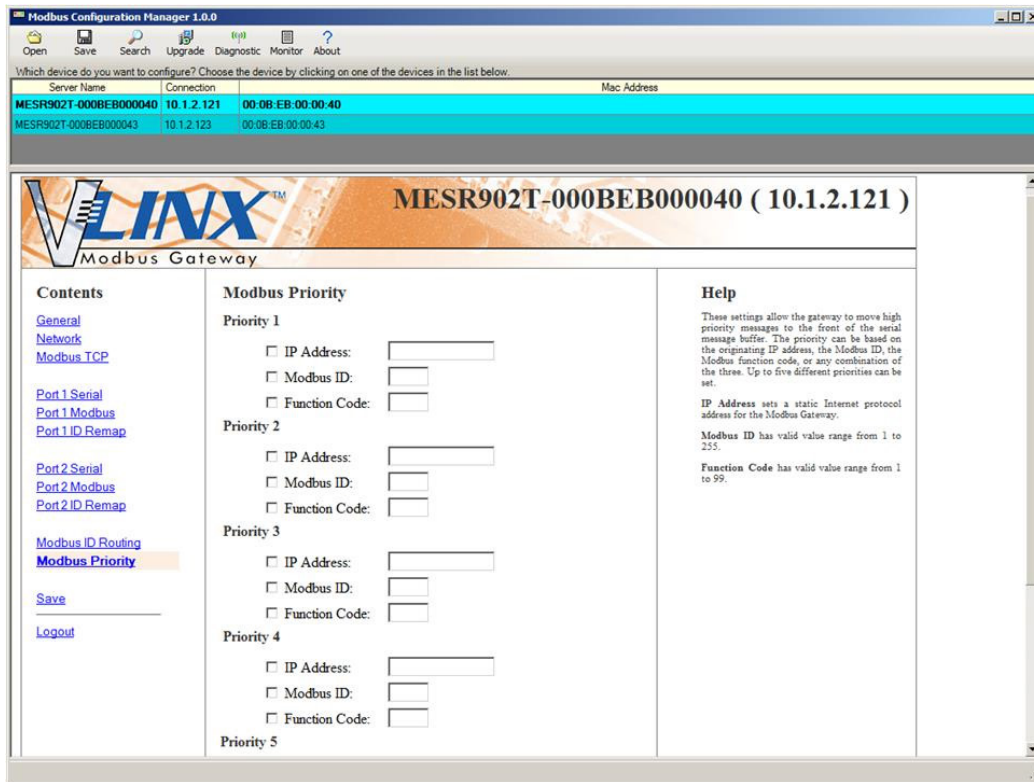

Figure 56. Modbus Priority

## Serial & Ethernet Masters, Serial & Ethernet Slaves

Your Modbus Gateway can also integrate multiple master devices onto serial and Ethernet Networks.

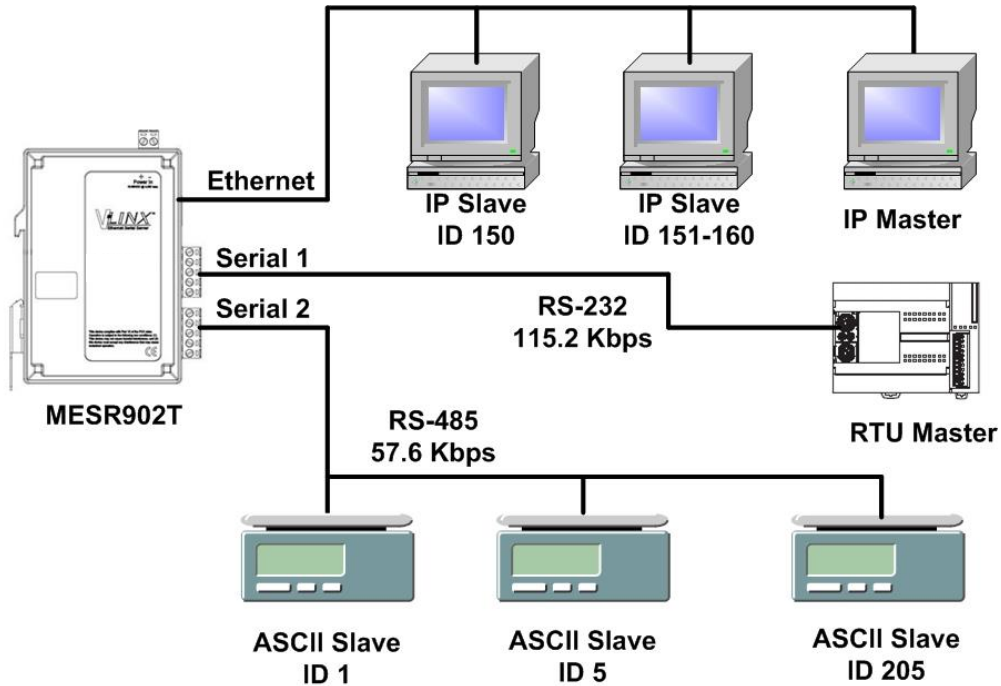

Figure 57. Serial & Ethernet Masters, Serial & Ethernet Slaves

1. In this example, Serial Port 1 has an RTU Master attached. Configure the serial port settings as appropriate for the device. Access the Port 1 Modbus screen and configure it the port for Modbus Master and RTU.



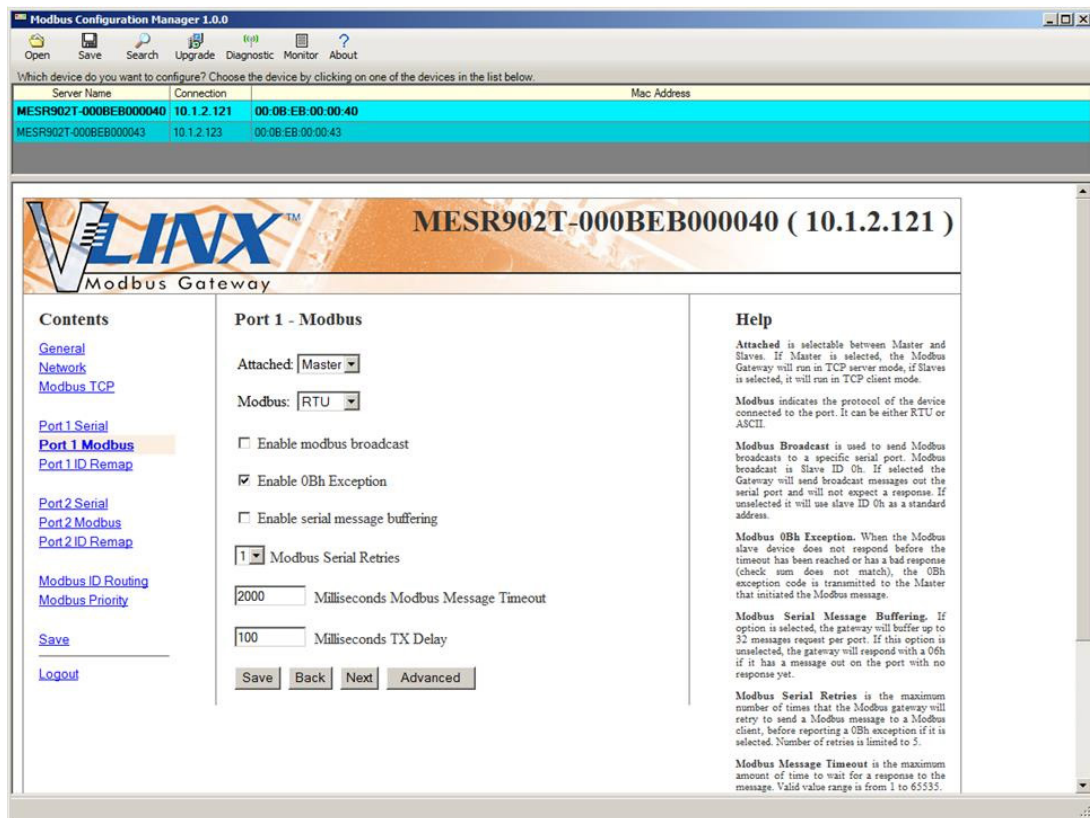

Figure 58. Port 1 Modbus

2. Configure the Modbus Slave ID routing. In this case Modbus Slaves 1 through 5 and 205 are on Serial Port 2. Modbus Slaves 150 and 151 through 160 have IP assignments.



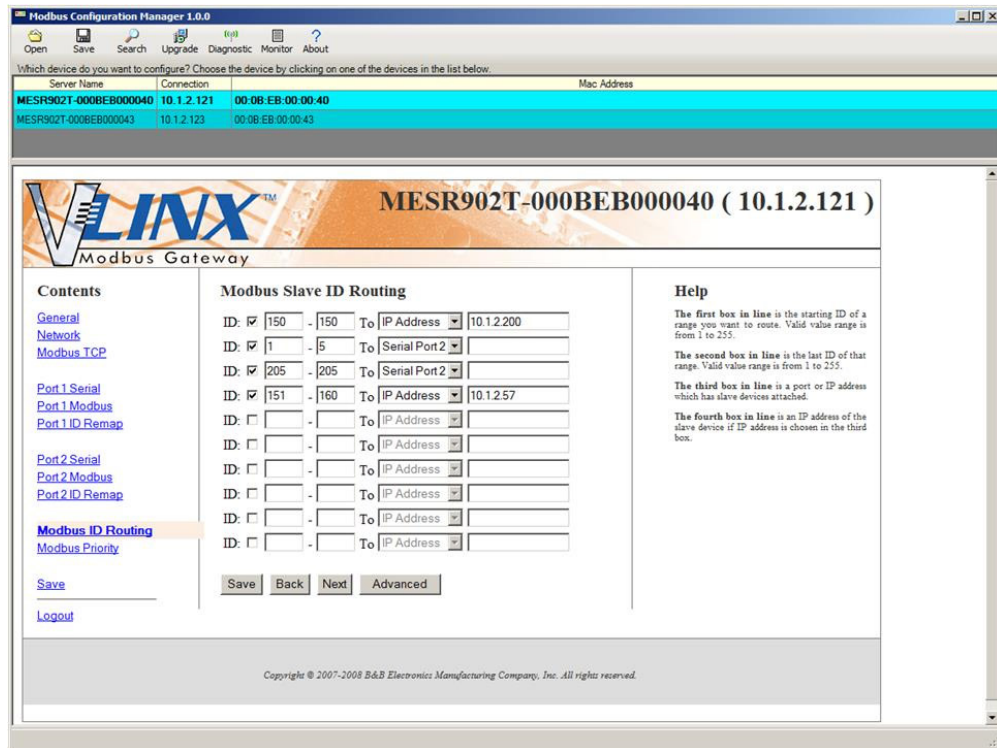

Figure 59. Modbus Slave ID Routing

### Serial Masters, IP Slaves

Serial Masters can be used to control IP Slaves.

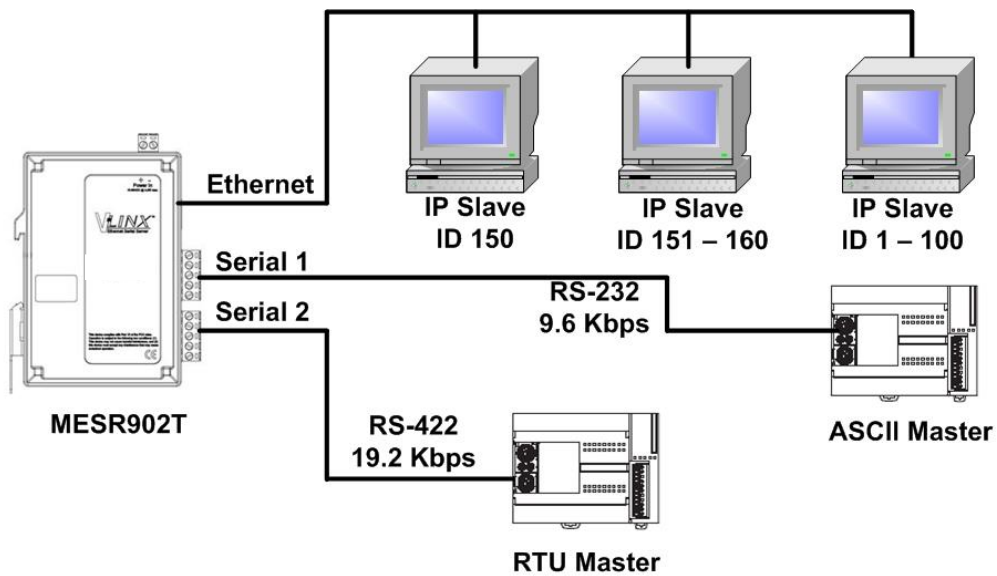

Figure 60. Serial Masters, IP Slaves

1. In this example, an ASCII Master is connected to Serial Port 1 and an RTU Master is connected to Serial Port 2. Configure the serial ports as appropriate for these devices.

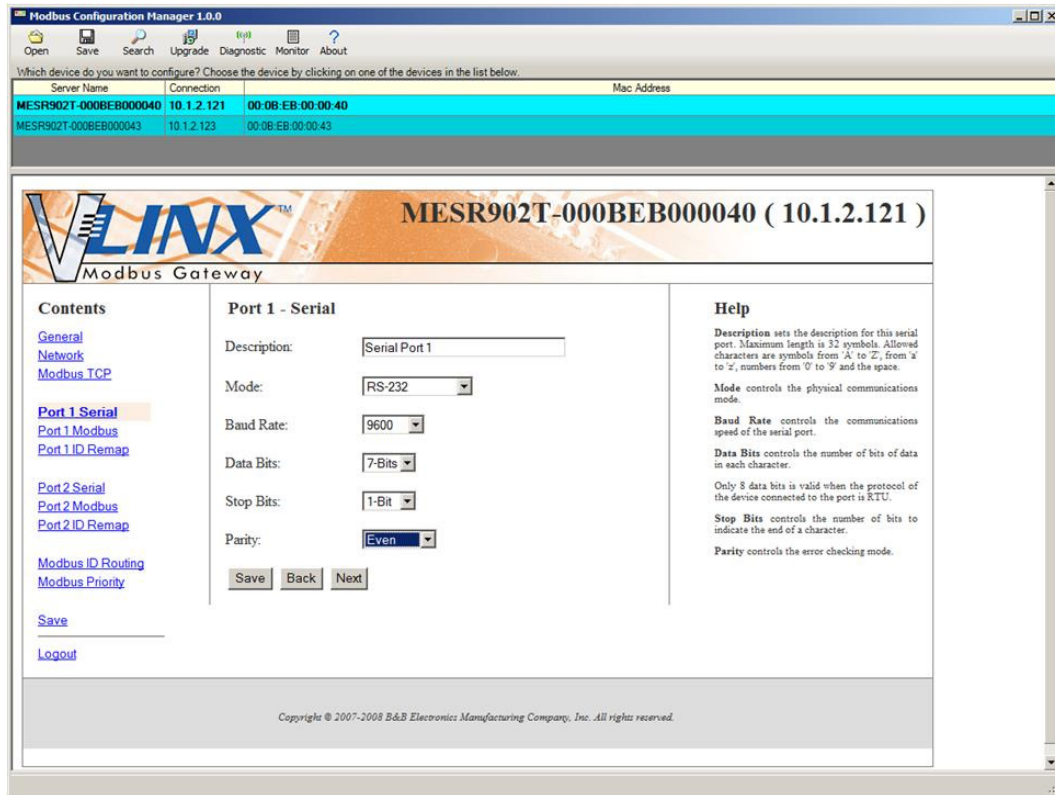

Figure 61. Port 1 Serial

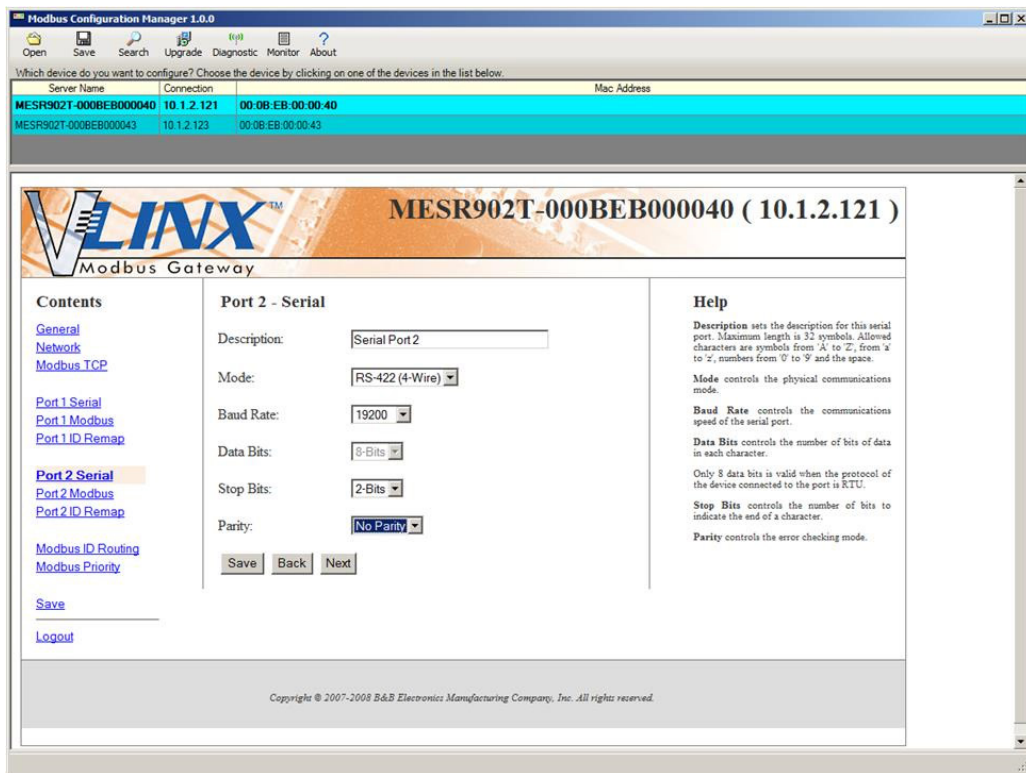

Figure 62. Port 2 Serial

2. Access the Modbus screen for each port and configure as appropriate. In this case, Port 1 has an ASCII Master and Port 2 has an RTU Master attached.

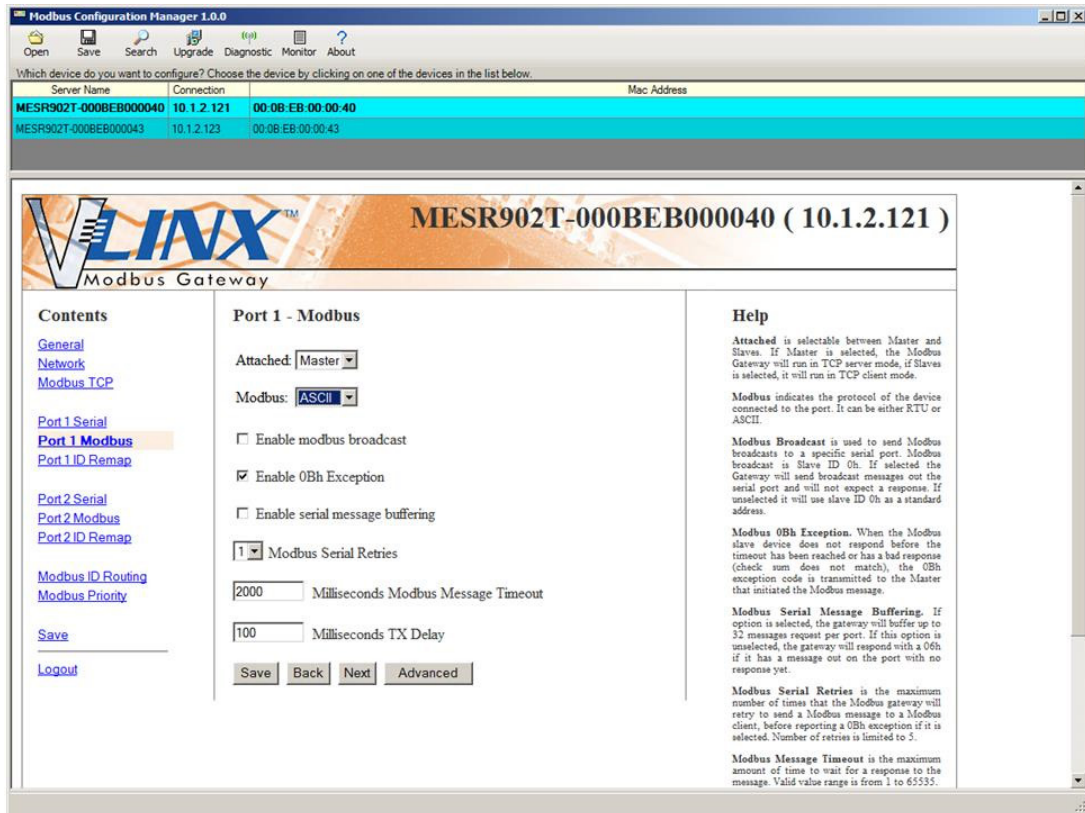

Figure 63. Port 1 Modbus

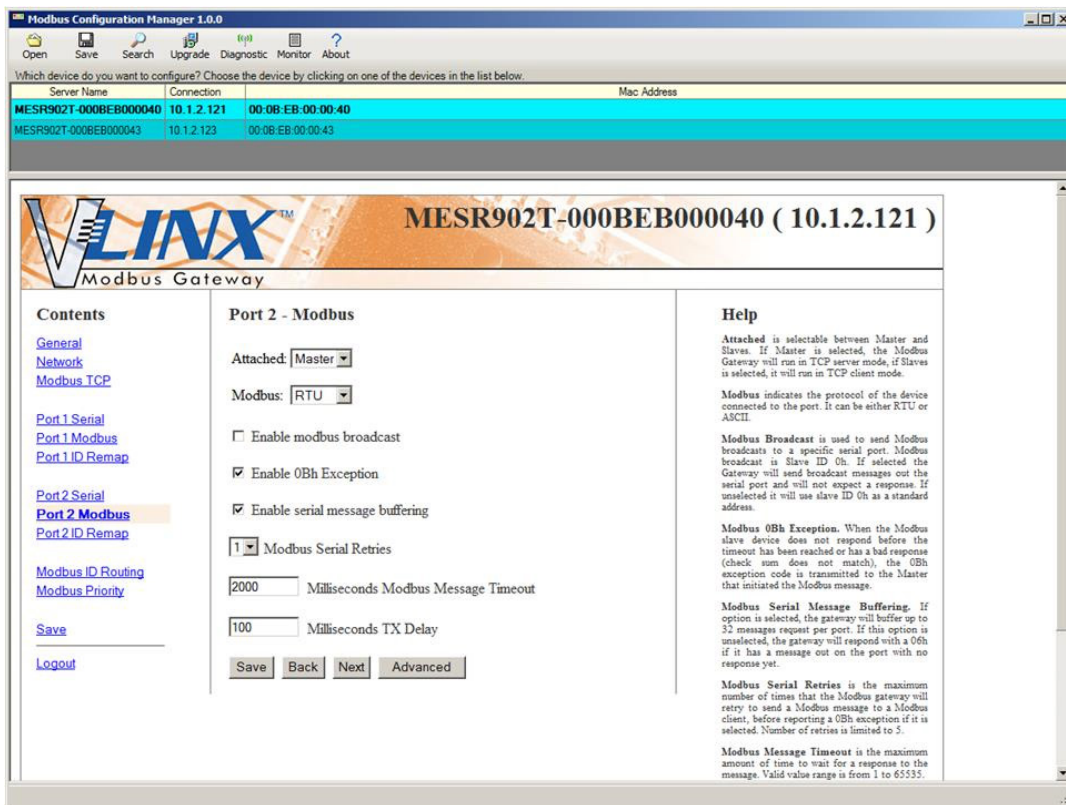

Figure 64. Port 2 Modbus

3. Setup the Slave ID Routing to associate IP addresses with the appropriate Slave ID.

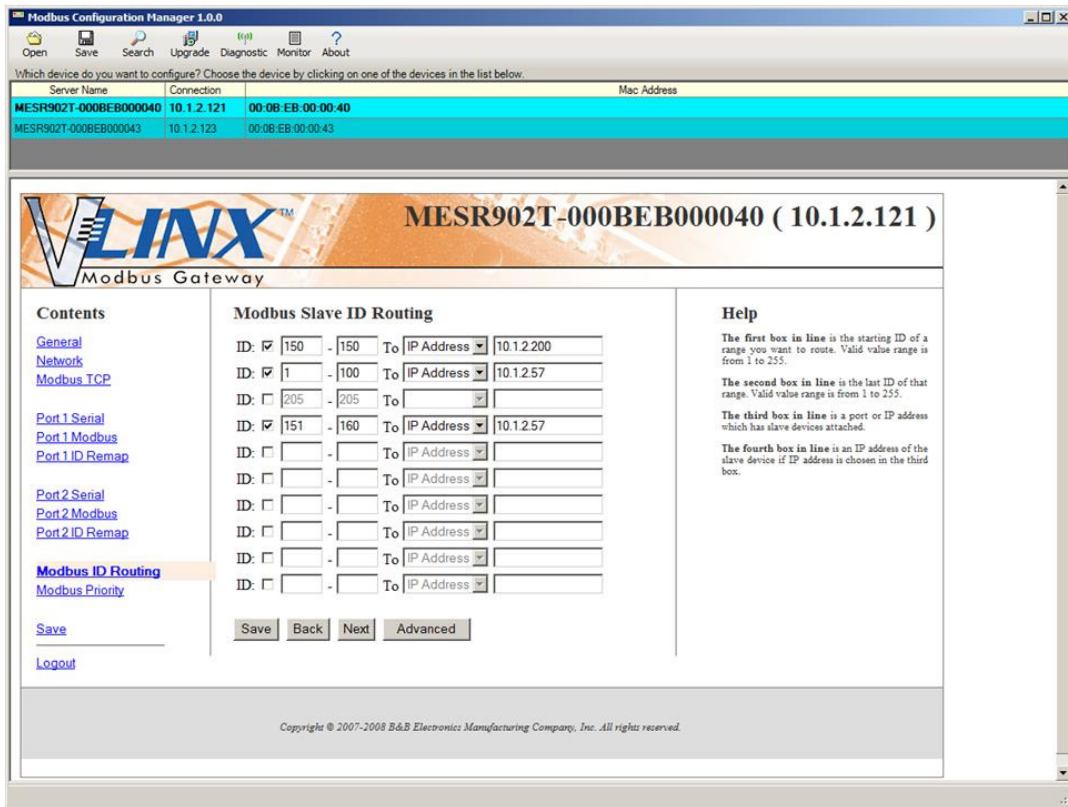

Figure 65. Modbus Slave ID Routing

### Identical Hard Coded Slaves

In this example, two slave devices that are hard coded with the same ID are required. This is accomplished by putting them on different serial ports.

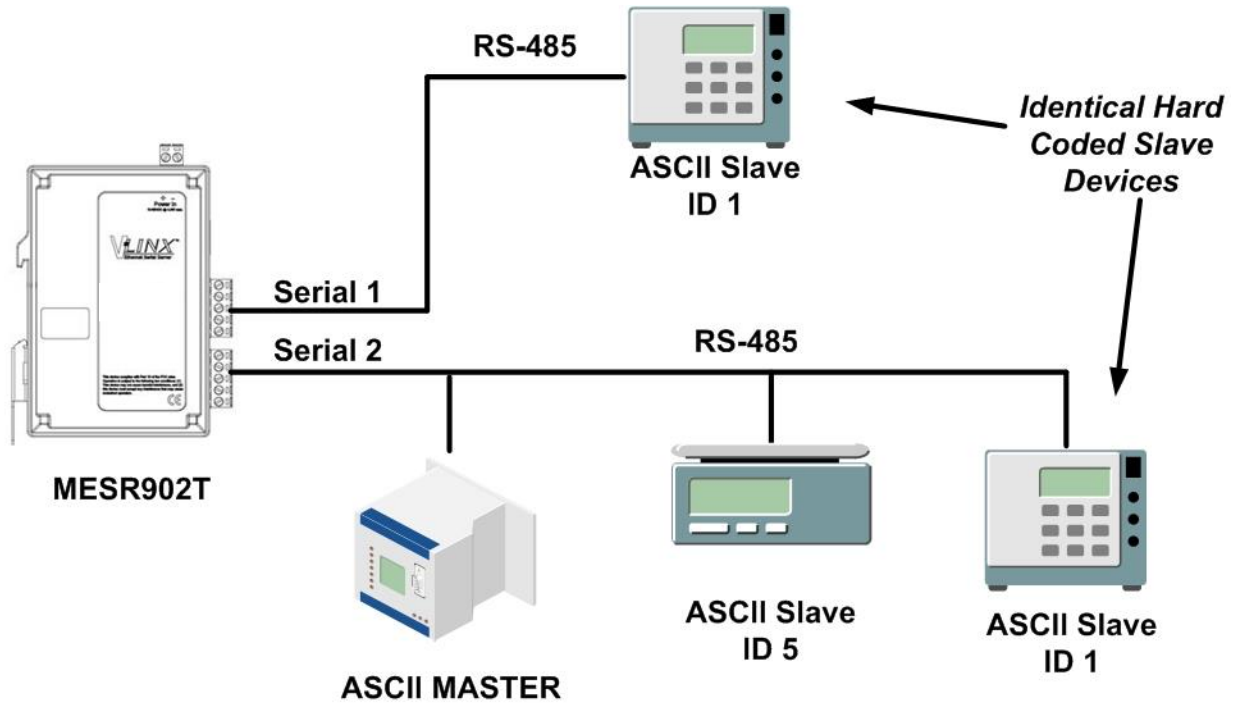

Figure 66. Identical Hard Coded Slaves



## Identical Production Lines

In this example, identical or backup production lines can be controlled by the same IP Master. This allows the duplicate networks to be configured identically, saving documentation and maintenance time.

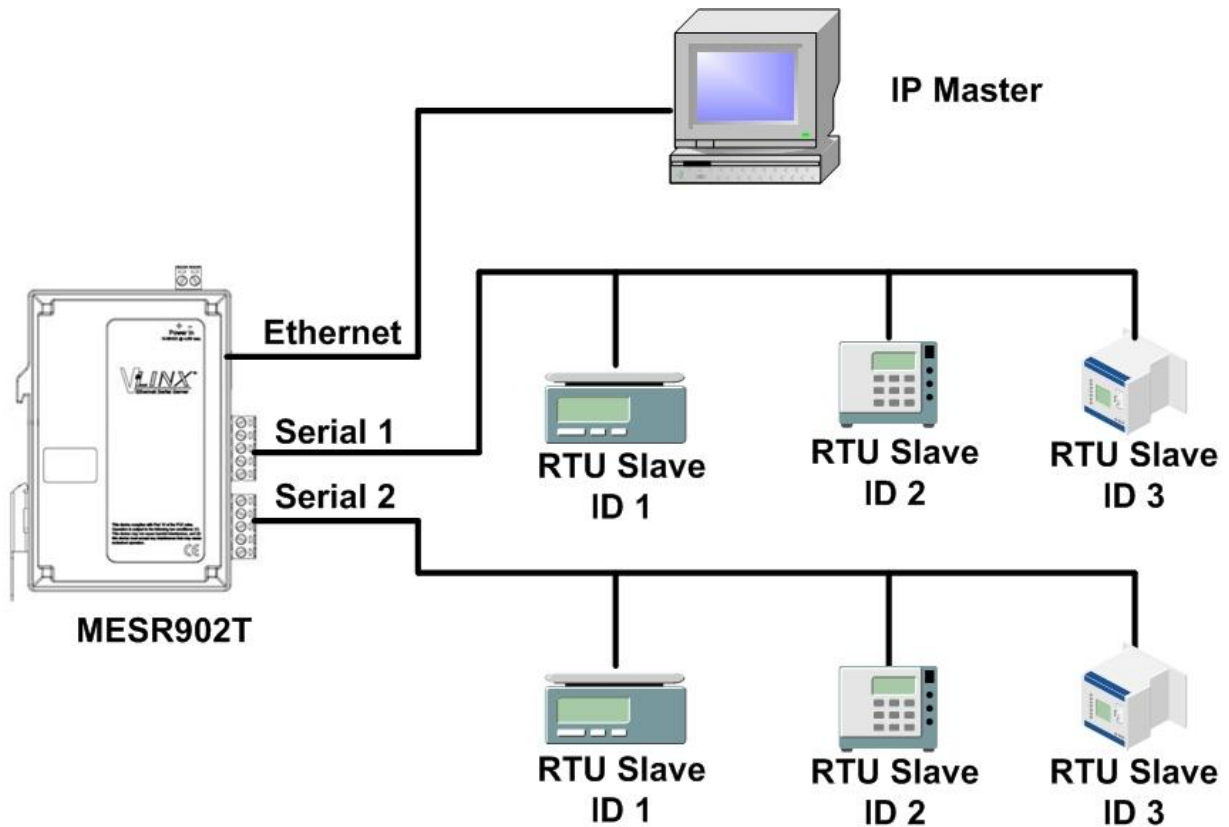

Figure 67. Identical Production Lines



## 7. Modbus Help

### Modbus ASCII/RTU Basics

The Modbus protocol emerged in the mid-1970s as an early protocol for linking terminals with Modicon PLCs using a master/slave (sometimes called a master/client) relationship. A simple, open, message-based protocol, it caught on quickly and became a de facto standard in the industry. It supports asynchronous point-to-point and multidrop communications and can be used with a variety of serial interfaces (RS-232, RS-422, RS-485, modems, etc).

The original Modbus specification included two possible transmission modes: ASCII and RTU. Modbus RTU mode is the most common implementation, using binary coding and CRC error-checking. Modbus ASCII messages, though somewhat more readable because they use ASCII characters, is less efficient and uses less effective LRC error checking. ASCII mode uses ASCII characters to begin and end messages whereas RTU uses time gaps (3.5 character times) of silence for framing. The two modes are incompatible so a device configured for ASCII mode cannot communicate with one using RTU.

All Modbus communications are initiated by Modbus masters using a polling query/response format. The master can send broadcast messages (using a slave address of 0), which all slaves accept, but do not reply to. More commonly the master polls individual slaves sequentially. In each poll it sends a message containing a **device address**, followed by a **function code**, any **data** that maybe required, and an **error check** field. The addressed slave responds with a similar message structure. Typically it repeats back its address and the function code, and then sends a field indicating the number of bytes of data it is sending, followed by the data and the error check field.

Slave addresses can range from 1 to 247. Function codes include several common ones typically used in all applications, and additional ones that may be implemented in specific cases. Common function codes include: Read Coil Status (01), Read Input Status (02), Read Holding Registers (03) and Read Input Registers (04).

When a master sends a message to a slave it expects to receive a valid response within certain length of time. If the slave does not receive the message, or if the slave receives the message but an error is detected, it does not respond. If the slave cannot respond appropriately for some other reason (e.g. it does not recognize the function code), it will return a message containing an exception response.

## ***Hints and Tips***

A few simple suggestions that may assist you if your system is experiencing problems include:

- Slowing down the polling rate may be helpful if power cycling doesn't cure the problem.
- A common misperception is that every serial network must terminate with a resistor. While this was true of early serial network configurations, it's typically the wrong answer – call our technical support and verify if you're an exception, at 815.433.5100 option 3.

A sometimes difficult problem is difference in grounding voltage between various network locations. Stray voltage from lightning or other sources may also find its way onto the network. These conditions make isolation necessary in many settings.

## **8. Appendices**

This section includes the following Appendices:

- Appendix A: Default Gateway Settings
- Appendix B: Product Specifications
- Appendix C: Dimensional Diagrams
- Appendix D: Connector Pinouts

## Appendix A: Default Gateway Settings

Setting	Default Value
GatewayName	User assigned
Password	password field is blank from factory
DHCP	Enabled
IP Address	DHCP will configure. If a DHCP Server is not available the unit will default to 169.254.102.39
Net Mask	255.255.0
Gateway	169.254.102.100
MAC Address	Fixed- see bottom label
Firmware Version	(Vx.x.x)
Hardware Version	(Vx.x.x)
Port	1, 2
Serial port mode	RS-232
Baud Rate	9600
Data bits	8
Parity	None
Stop bits	1
Flow Control	None
Protocol	TCP
Serial timeout	0 seconds
Inter-character timer	0 ms
TCP port	Port 1 = 4000 Port 2 = 4001
Max connection	1

## **Appendix B: Product Specifications**

This section includes the following specifications:

- General Specifications
- Controls, Indicators and Connector Specifications
- Serial Interface Specifications
- Network Specifications

## General Specifications

<b>Hardware and included accessories</b>	Device	MESR901-x, MESR902D-x or MESR902T-x Modbus gateway module
	CD	CD with Vlinx Modbus Manager software for Windows 2000, XP (32/64 bit), 2003 Server (32/64 bit), Vista (32/64 bit), 2008 Server (32/64 bit), Windows 7 (32/64 bit)
<b>Optional Accessories</b>	Cable	232NM9 Null Modem Crossover Cable for DTE to DTE connection
	Rail	ERS35 one-meter length of steel 35mm DIN Rail
<b>Configuration Options</b>	Via serial port	Using Vlinx Modbus Manager via a serial connection, (press Reset button to enter Console Mode)
	Via network	Using Vlinx Modbus Manager via a Ethernet connection Using a standard web browser such as Internet Explorer 6.0/7.0 or Firefox 1.5/2.0
<b>Software</b>	Vlinx Modbus Manager for Modbus gateway configuration	Windows 2000, XP (32/64 bit), 2003 Server (32/64 bit), Vista (32/64 bit), 2008 Server (32/64 bit), Windows 7 (32/64 bit)
<b>Environment</b>	Operating Temperature	-40 to 80 °C (-40 to 176 °F)
	Storage Temperature	-40 to 85 °C (-40 to 185 °F)
	Operating Humidity	10 to 95% non-condensing
<b>Certifications</b>	FCC	Part 15 Class A
	CE	
	UL	UL Listed, File E222870
	UL Class1 Div2	Groups A, B, C, D (HAZLOC) File E245458
	TS2	
<b>Enclosure</b>	Rating	IP30
	Mounting	DIN rail mount (35 mm)
	Dimensions, Medium Case (MESR92x)	1.2 x 4.5 x 6.2 in (2.8 x 11.4 x 15.7 cm)
	Dimensions, Small Case (MESR90x)	1.2 in x 3.3 x 4.7 in (3.1 x 8.4 x 11.9 cm)
<b>Power Supply (External Supply Required)</b>	Voltage Requirements	10 to 48 VDC (58 VDC Max)
	Power Consumption	MESR90x – 4.0W (Max) MESR92x – 6.0W (Max)

<b>Terminal Blocks</b>	Wire Size	28 to 16 AWG
	Wire Type	Copper Wire Only
	Tightening Torque	5 KG-cm
	Wire Temp Rating	105°C Minimum, Sized for 60°C Ampacity
	Note	One conductor per terminal

### **Controls, Indicators and Connector Specifications**

<b>Switches</b>	Reset button	Hold in for 0 to 2 seconds for hardware reset Hold in for 2 to 10 seconds for Console Mode (Do a hardware reset or recycle power to exit Console Mode) Hold in for more than 10 seconds to reset to factory defaults
<b>Indicators</b>	Serial LED (one per port)	Color = Green On = Port open Blink = Data traffic
	Link LED	Color = Green On = 100BaseTX Off = 10BaseT Blink = Data traffic
	Ready LED	Color = Green Blink (once per second) = System OK Off = System NOT OK
<b>Connectors</b>	10BaseT/100BaseTX Ethernet	Single RJ-45F (8 pin)
	SC fiber	SC connector
	ST fiber	ST connector
	Serial	MESR901-x: one DB-9M connector
		MESR902D-x: Two DB-9M connectors
		MESR902T-x: Two pluggable lockable 5.08 mm terminal blocks
DC Power	5.08mm 2-position pluggable, lockable terminal block	

### Serial Interface Specifications

Mode Selection	RS-232/422/485 software selectable
RS-232 lines	TXD, RXD, RTS, CTS, DTR, DSR, DCD, GND
RS-422 lines	TXDA(-), TXDB(+), RXDA(-), RXDB(+), GND
RS-485 lines (2 wire)	Data(-), Data(+), GND
RS-485 lines (4 wire)	TXDA(-), TXDB(+), RXDA(-), RXDB(+), GND
Baud Rates	75, 150, 300, 600, 1200, 2400, 4800, 7200, 9600, 14400, 19200, 28800, 38400, 57600, 115200, 230400
Data Bits	5, 6, 7, 8
Parity	None, even, odd, mark, space
Stop bits	1, 1.5, 2
Flow control	None, RTS/CTS, XON/XOFF
RS-422/485 biasing	Auto 4.7K ohm pullups and pulldowns
RS-422/485 termination	Auto termination with thru hole resistor (user supplied)
RS-485 data control	Auto control via MCU



## Network Specifications

<b>Memory</b>	Serial Memory	10 K bytes per port
	Network Memory	10 K bytes
<b>I/P Port Addresses</b>	5300	Configuration setting in TCP Mode
	8888	MESR901 update
<b>Network Communications</b>	LAN	10/100 Mbps Auto-detecting 10BaseT or 100BaseTX
<b>Network Physical Layer Standards</b>	Ethernet	IEEE 802.3 auto-detecting & auto MDI/MDX 10BaseT and 100BaseTX
<b>Protocols Supported</b>		TCP, IPv4, ARP, HTTP 1.0, ICMP/PING, DHCP/BOOTP
	IP Mode	Static, DHCP or Auto IP
<b>Connection Modes</b>	TCP	User definable
		Server, Client,
<b>Search</b>		Serial direct COM and Ethernet auto search or specific IP
<b>Firmware Upgrade</b>		Via serial, Ethernet or auto web search
<b>Character count</b>		0 to 65535
<b>Timeouts</b>	Character	0 to 65535 ms, default set at 10 ms
	Modbus Message	0 to 65535 ms, default set at 1,000 ms
	Serial	0 to 65535 sec

### Appendix C: Dimensional Diagrams

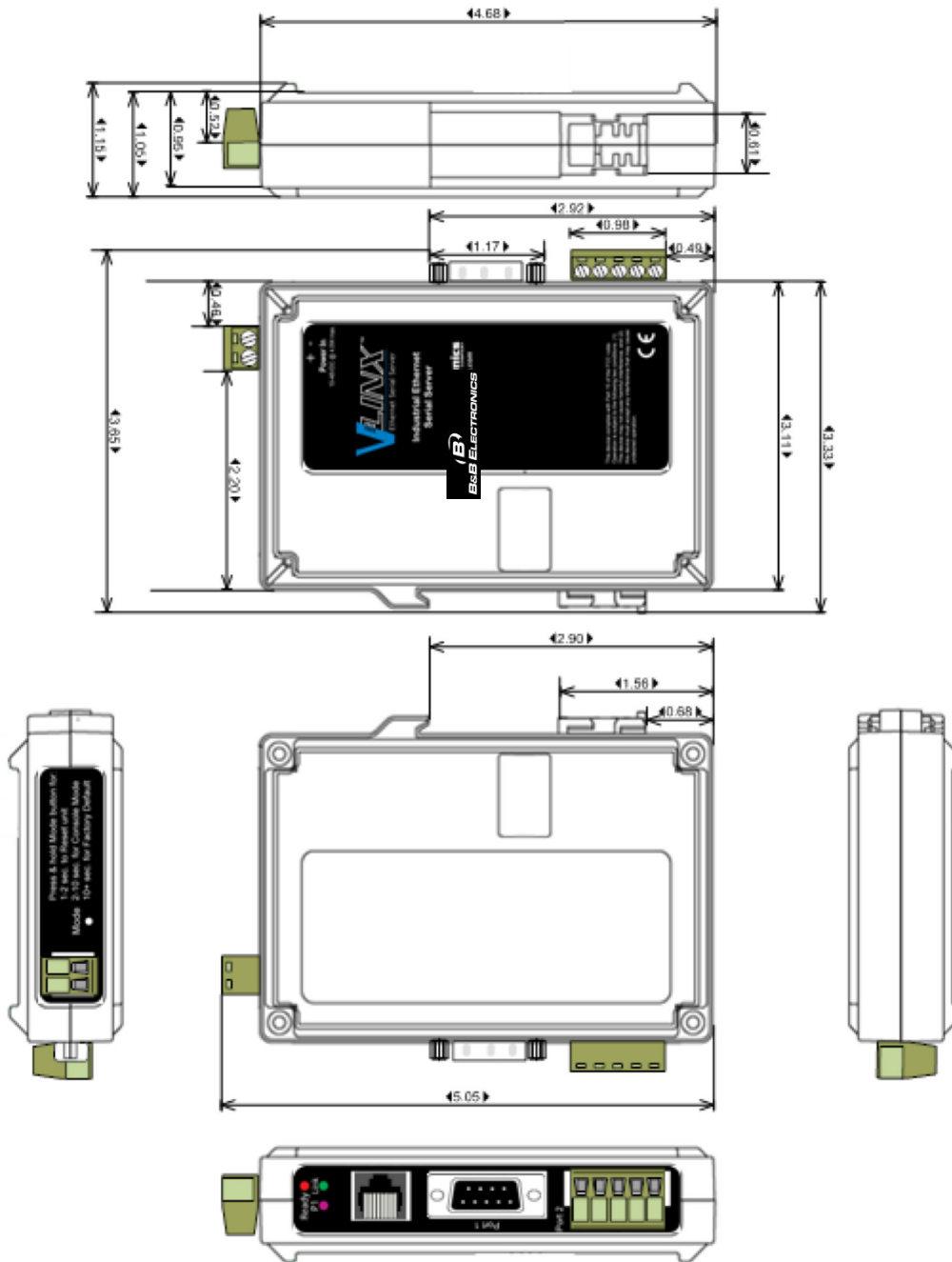
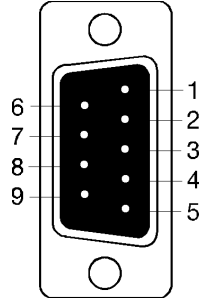

Figure 68. Dimensional Diagram of an MESR901 Modbus Gateway

## Appendix D: Connector Pinouts

### MESR901 Serial Port Pinouts



DB9M Pin	Direction	RS232
1	Input	DCD
2	Input	RXD
3	Output	TXD
4	Output	DTR
5	---	GND
6	Input	DSR
7	Output	RTS
8	Input	CTS
9	Input	RI

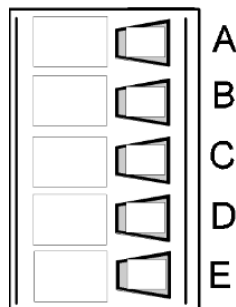

Terminal	RS-422/485 4-Wire	RS-485 2-Wire
A	TDA (-)	Data A (-)
B	TDB (+)	Data B (+)
C	RDA (-)	---
D	RDB (+)	---
E	GND	GND

**Standard Ethernet Cable RJ-45 Pin-out**

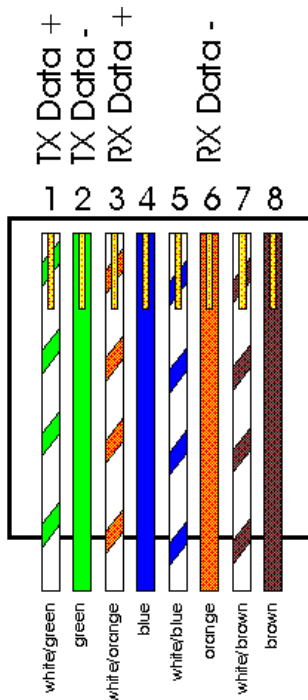

RJ-45 Pin	Signal	Wire Color
1	TX+	WhiteGreen
2	TX+	Green
3	RX+	WhiteOrange
4	Not used	Blue
5	Not used	WhiteBlue
6	RX-	Orange
7	Not used	WhiteBrown
8	Not used	Brown

## 9. Glossary

<b>Term</b>	<b>Definition</b>
<b>ADU</b>	Application Data Unit
<b>ASCII</b>	American Standard Code for Information Interchange
<b>Baud Rate</b>	Number of bits per second
<b>CRC</b>	Cyclical Redundancy Checking
<b>Data Bits</b>	Number of bits per byte, normally 7 with Modbus ASCII, and 8 with Modbus RTU
<b>DHCP</b>	Dynamic Host Configuration Protocol
<b>Flow Control</b>	The process of managing the rate of data transmission between two nodes.
<b>Function Code</b>	A code field that tells the Gateway what kind of action to perform
<b>Modbus Gateway</b>	A bridge to get from Modbus TCP to Modbus Serial
<b>GUI</b>	Graphical User Interface
<b>IP</b>	Internet Protocol
<b>IPv4</b>	Internet Protocol version 4
<b>LED</b>	Light emitting diode. Used as a visual indicator
<b>MBAP</b>	MODBUS Application Protocol
<b>MEI</b>	Multi Electrical Interface via RS-232/422/485
<b>MES1A</b>	B&B's Ethernet Modbus gateway, RS-232 on serial port
<b>MES1B</b>	B&B's Ethernet Modbus gateway, RS-422/485 on serial port
<b>MESR922T</b>	B&B's Ethernet Modbus gateway, Dual Ethernet ports, Dual serial ports with MIE and terminal blocks
<b>Modbus</b>	A request/reply protocol and offers services specified by function codes.
<b>Parity Bit</b>	A binary digit that is added to ensure that the number of bits with value of one in a given set of bits is always even or odd. It may also be a Mark (1), or a Space (0).
<b>PDU</b>	Protocol Data Unit

<b>Term</b>	<b>Definition</b>
<b>RS-232</b>	Interface between Data Terminal Equipment and Data Circuit-Terminating Equipment Employing Serial Binary Data Interchange
<b>RS-422</b>	Electrical Characteristics of Generators and Receivers for Use in Balanced Digital Point to Point Systems
<b>RS-485</b>	Electrical Characteristics of Generators and Receivers for Use in Balanced Digital Multipoint Systems
<b>RTU</b>	Remote Terminal Unit
<b>Stop Bit</b>	Number of bit times after a character is transmitted before the next character can start transmission.
<b>TCP</b>	Transmission Control Protocol
<b>Unit ID</b>	Unit Identifier. This is the same as the slaves address.
<b>MESR</b>	B&B's Modbus Ethernet Gateway Series
<b>Vlinx</b>	B&B's family name for the Gateway line