

General Specifications

Model DO402G Dissolved Oxygen Converter

EXA 00

GS 12J05D02-00E

[Style: S3]

Flexibility, reliability and low maintenance are among the benefits provided by the DO402G dissolved oxygen converter. Designed to meet the exacting requirements of measuring dissolved oxygen in the modern industrial environment, it contains many features to ensure the best precision whatever the application.

This 4-wire converter is housed in a robust IP65, NEMA 4X, CSA Type 3S field mountable case. Two mA outputs, four relays and a clear LCD make the DO402G a truly comprehensive package.

The DO402G features PI control on both the auxiliary mA output and the pulse proportional relay outputs, thus avoiding the need for a separate controller.

The famous EXA sensor diagnostics are now expanded. This can be used to record events like calibration and diagnostic messages, and to update configuration of the converter remotely.

The DO402G accepts inputs from optical, galvanic and polarographic sensors. Percent saturation, mg oxygen/l water, and ppm DO can be displayed and transmitted. Compensation for atmospheric pressure altitude, salinity and temperature are included for the best accuracy of measurement.

Features

- Versatile sensor inputs
- On-line sensor checking monitors integrity of membrane
- Four fully configurable SPDT contact outputs
- Two fully configurable mA outputs
- Built-in PI controller
- Easy to use EXA control panel

Refer to GS 12J05D03-01E for DO30G, GS 12J05D04-01E for DO70G and GS 12J05C02-00E for holders.



DO402G Dissolved Oxygen Converter



DO70G Optical Dissolved Oxygen Sensor



DO30G Galvanic Dissolved Oxygen Sensor



PB350G Floating Ball Holder

Accurate dissolved oxygen

Operating principles

The DO402G can be used with optical, galvanic and polarographic sensors, giving added flexibility in a wide range of applications.

For the membrane covered electrochemical, galvanic and polarographic, sensors, dissolved gaseous oxygen diffuses through the membrane, and gives rise to a reaction at the electrodes. The resulting current is proportional to the oxygen concentration in the process solution.

For the optical sensors, when excitation light from internal LED is irradiated on a luminophore, red light is generated on the luminophore through luminescence caused after excitation.

The red light phase shift provides accurate indication of oxygen concentration. The resulting current is proportional to the phase shift of the light.

Display functions and ranges

The display continuously gives you all necessary information at a glance. The process values are shown in easy readable programmable units. Either mg/l, % saturation or ppm can be chosen.

The user-interface is simplified to a basic set of 6 keys accessible through the flexible window cover. It uses a simple step by step, question and answer style to communicate with the operator by giving messages on the second line of the display and indicating which keys are to be pressed in the display.

Automatic air calibration

Calibration for a dissolved oxygen instrument is performed by simple air calibration.

Criteria for automatic calibration (stabilization time, DO values) can be set to suit the sensor.

In addition to the air calibration three additional calibration procedures can be used:

1. Span calibration using air saturated water
2. Zero calibration using sulphite saturated water
3. Process calibration using laboratory reference method

Automatic wash cleaning (only DO30G)

The DO402G can be used to generate a contact closure to control a wash cleaning cycle. The interval, wash and recovery times are adjustable for optimum operation. Yokogawa immersion assemblies can be supplied with wash cleaning nozzles to provide on line cleaning for the sensor membrane or the sensor cap.

Salinity compensation

In order to take the effect of salinity into account for oxygen measurement an average chloride concentration can be programmed. The chloride concentration value is set manually via the service level. The DO402G takes account of the effects of salinity and temperature simultaneously. The advantage of this is the influence of salt concentration temperature have on the solubility of oxygen is automatically compensated, for highly accurate analyses, without the need for a conversion table.

Temperature compensation

The micro-processor makes an accurate temperature compensation possible that performs well over the entire range of the instrument. No further adjustment tables are required.

Barometric air pressure compensation

Air pressure differences, due to weather conditions or altitude, can cause a variation up to 20 % in the dissolved oxygen concentration. A built-in air pressure sensor automatically compensates for barometric influences between 900 to 1100 mbar (90 to 110 kPa).

Sensor diagnostics

DO30G sensor is checked for low impedance between the silver electrode and an earth connection in the liquid, to detect membrane integrity. Temperature sensor connections and sensor connections are checked for impedance. These faults are signaled by the FAIL contact and can be signaled to the control room by an output of 22 mA or 3.5 mA (0 mA) (Burn out). The fault is also signaled by a special marker held on the display, a LED on the front and an error code in the message display.

During calibration of a DO measuring system the slope deviation from nominal value (%) and sensor output (μ A) at 0 mg/l are calculated and checked.

If any of these are outside the limits, an error is signaled.

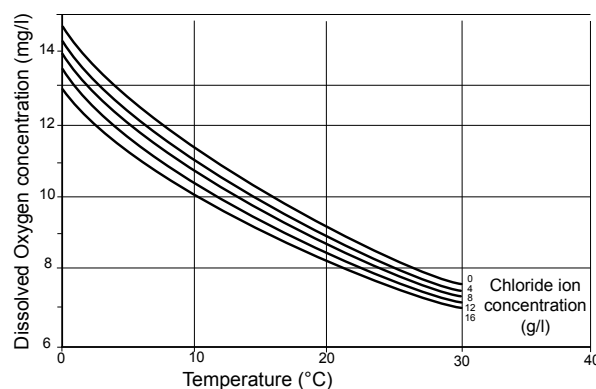

Fig.1. Salinity compensation Output signals

Output signal

The standard DO402G features two 0-20 mA or 4-20 mA current outputs available for recording, and indication or control functions.

The user selectable outputs can represent:

- dissolved oxygen mg/l or ppm
- saturation value %
- measured temperature value

In addition the following output functions are available:

- a "HOLD" function that maintains last measured value or a fixed value until return to normal operation
- a "BURN" function that gives a high or low output at fail status
- a programmable output function that allows the user to linearize the output(s).
- a damping time constant can be set to even out random process fluctuations that can make the real value difficult to see.

Cables and terminals

The DO402G is equipped with terminals suitable for the connection of finished cables in the size range of 0.13 to 4 mm² (26 to 12 AWG)

The glands will form a tight seal on cables of outside diameter in the range 6 to 12 mm (0.24" to 0.47").

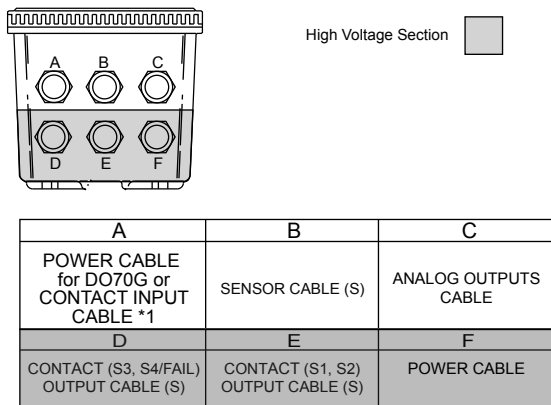

Fig.2. Glands to be used for cabling

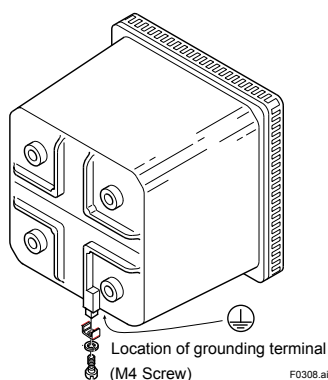

Fig.3. Grounding

*1: Use D or E for cable gland of DO70G power cable when both DO70G and contact input are used.

Three level operation

The DO402G converter uses a 3-level operating system to take full advantage of the microprocessor while retaining the traditional simplicity of analog converters. Advanced functions are separated from conventional operation to avoid confusion. They can be activated as required for each individual application.

1. The normal maintenance functions are accessible through the flexible window by pushing the keys underneath.
2. Functions required to commission the instrument are hidden to discourage unauthorized tampering. The front cover is removed to reveal the commissioning menu and the hidden access key (marked*).
3. Specialized functions can be adjusted via the SERVICE menu. In this case access is by using "service codes."

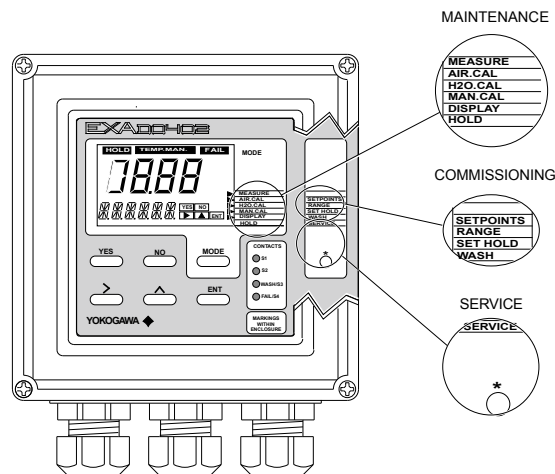

Fig.4. Three level operation

MAINTENANCE level

Use : Normal operation and checking
 How : Simple operation by dialog through the closed front cover
 Example : Calibration

COMMISSIONING level

Use : For normal commissioning
 How : Removal of the front cover reveals the access key and second menu
 Example : Output range setting

SERVICE level

Use : Only for specialized functions
 How : Through special service code entries
 Example : Selecting salinity compensation

With this 3-level user-friendly approach, the instrument can be operated by anyone. Commissioning is straightforward and needs no calibration equipment compared to analog instruments. Special functions available via access codes are invisible during normal operation. All three levels can be separately protected against unauthorized access by a password system using a three digit code.

General Specifications

A. Input specifications

: The DO402G Dissolved Oxygen converter measures the current that is generated by the Dissolved Oxygen sensor. The flexibility of the input circuit allows the use of many commercially available sensors, whether they are the Galvanic (driving voltage generated internally), Polarographic (driving voltage supplied by converter) or Optical (driving voltage supplied by power supply unit).

The input range varies from 0.0 nA up to 500 nA for polarographic or optical sensors and 0.0 to 50 μ A for galvanic sensors. Temperature measurement for automatic temperature compensation utilizes Pt100, Pt1000, 22k NTC or PB36.

B. Input ranges

- Dissolved Oxygen: 0- 50 mg/l (ppm)
- Temperature : 0- 50 °C (32- 122 °F)

C. Span

- DO concentration: minimum: 1 mg/l (ppm)
maximum: 50 mg/l (ppm)
- % saturation : minimum: 10 %
maximum: 300 %
- Temperature : minimum: 25 °C (77 °F)
maximum: 50 °C (122 °F)

D. Transmission signals

- : Two isolated outputs of 0/4-20 mA DC with common negative.
Maximum load 600 Ω.
Auxiliary output can be chosen from temperature, DO, PI control, table, burn up (22 mA) or burn down (0 or 3.5 mA) to signal failure.

E. Temperature compensation

- : 0-50 °C
Sensor types: Pt100, Pt1000, PB36 ,22k NTC
Automatic or Manual temperature compensation.

F. Calibration

- : Semi-automatic calibration with automatic compensation for influence of barometric pressure and altitude on partial pressure of Oxygen in air (or solubility of Oxygen in water). Automatic compensation for influence of salinity of water on solubility of Oxygen in water is programmable.
The correction for pressure, salinity and temperature meets ISO 5814
Possible calibration routines are:
 - Slope (span) calibration in ambient air. The calibration table is based on 70% rH and is determined empirically.
 - Slope (span) calibration in water, saturated with air: according ISO 5814
 - Zero calibration (normally inactive)

G. Display

- : Custom liquid crystal display, with a main display of 3 1/2 digits 12.5 mm high. Message display of 6 alphanumeric characters, 7 mm high.

H. Contact outputs

- General : Four (4) SPDT relay contacts with LED indicators. For S1, S2, and S3, the LED is on when relay is powered.
NOTE:
For S4 (FAIL) LED lights when power is removed (Fail safe).
Contact outputs configurable for hysteresis and delay time.
- Switch capacity : Maximum values 100 VA, 250 VAC, 5 Amps.
Maximum values 50 Watts, 250 VDC, 5 Amps.

- Status : High/low process alarms, selected from conductivity, resistivity and temperature.
Contact output is also available to signal "Hold active"
- Control function: On / Off
PI pulsed : Proportional duty cycle control with integral term.
- PI frequency : Proportional frequency control with integral term. In addition wash cleaning control signal on S3, and FAIL alarm for system and diagnostic errors on S4.

I. Contact input

- When DO70G is connected, contact input cannot be used.
Voltage-free contact (do not apply voltage)
Wash start or input remote range change (either choice)
 - On resistance: 10Ω or less
 - Off resistance: 100kΩ or more
 - On time: 0.5 sec. or more
 Note: At the circumstance influenced from noise (e.g. long transmission of contact input), insertion of a relay near DO402G is recommended for insulating.

J. Power supply:

- Voltage ratiuss (Applicable range):
 - 100 V (85 to 115 V) AC
 - 115 V (97.8 to 132.2 V) AC
 - 230 V (195.5 to 264.5 V) AC
- Supply frequency rating (Applicable range):
50 / 60 Hz (± 5%)
- Power consumption: 10 VA maximum for steady operation

K. Safety and EMC conforming standards

- Safety:** conforms to EN 61010-1
EN 61010-2-030
EN 61010-2-201
CAN/CSA No.61010-1
UL Std. No. 61010-1
CSA C22.2 No. 94.2
UL 50E
- EMC:** conforms to EN 61326-1 Class A, Table 2 (Note 1)
EN 61326-2-3
EN 61000-3-2 Class A
EN 61000-3-3
RCM: EN61326-1 Class A
Korea Electromagnetic Conformity Standard Class A 한국 전자과적합성 기준

- Category based on IEC 61010: II (Note 2)
- Pollution degree based on IEC 61010: 2 (Note 2)
- Installation altitude: 2000 m or less

Note 1: This instrument is a Class A product, and it is designed for use in the industrial environment. Please use this instrument in the industrial environment only.

Note 2: Installation category, called over-voltage category, specifies impulse withstand voltage. Category II is for electrical equipment. Pollution degree indicates the degree of existence of solid, liquid, gas or other inclusions which may reduce dielectric strength. Degree 2 is the normal indoor environment.

Operating Specifications

- A. Performance** : DO (at t process = 25 °C)
- Linearity : ± 0.03 mg/l or $\pm 0.5\%$ FS, whichever is greater
 - Repeatability : ± 0.03 mg/l or $\pm 0.5\%$ FS, whichever is greater
 - Accuracy : ± 0.05 mg/l or $\pm 0.5\%$ FS, whichever is greater

B. Performance : Temperature (Pt1000, 22k NTC, PB36)

- Linearity : ± 0.3 °C
- Repeatability : ± 0.1 °C
- Accuracy : ± 0.3 °C

Performance : Temperature (Pt100)

- Linearity : ± 0.4 °C
- Repeatability : ± 0.1 °C
- Accuracy : ± 0.4 °C

Note on performance specifications:

The specifications are expressed with simulated inputs, because the DO402G can be used with many different sensors with their unique characteristics.

The following tolerance is added to above performance.

mA output tolerance : ± 0.02 mA of "0/4 - 20 mA"

Digital display tolerance : +1 digit

C. Response time

- 0- 90% : 10 s

D. Ambient operating temperature

- : -10 to + 55 °C (14 to 131 °F)

E. Storage temperature

- : -30 to +70°C (-22 to 158 °F)

F. Humidity : 10 to 90% RH non-condensing

G. Housing

- Case : Cast aluminum with chemically resistant coating
- Cover : Flexible polycarbonate window
- Case color : Off-white (Munsell 2.5Y8.4/1.2)
- Cover color : Moss green (Munsell 06GY3.1/2.0)
- Cable entry : Via six PG13.5 nylon glands
- Cable terminals : For up to 2.5 mm² finished wires
- Protection : Weather resistant to IP65, NEMA 4X, CSA Type 3S
- Mounting : Pipe wall or panel, using optional bracket.

H. Data protection: Lithium battery for clock support.

I. Watchdog timer: Checks microprocessor

J. Automatic safeguard : Return to measuring mode when no keystroke is made for 10 min.

K. Power interruption: Less than 50 milliseconds no effect.

L. Operation protection: 3-digits programmable password.

M. Connection cable: When use DO30G, the distance between sensor and the transmitter will be maximum 50m if WTB10 terminal box is connected.
(DO70G cannot connect to WTB10. The distance between DO70G and the transmitter is always maximum 10m.)

Model and suffix codes

[Style: S3]

Model	Suffix code	Option code	Description
DO402G	-----	-----	Dissolved Oxygen Converter
Type	-1	-----	General
Power Supply Voltage	-1	-----	115V +/-15% AC, 50/60 Hz (*2)
	-2	-----	230V +/-15% AC, 50/60 Hz
	-5	-----	100V +/-15% AC, 50/60 Hz
Language	-E	-----	English
	-J	-----	Japanese
Options			
Mounting Bracket	/U		Pipe, wall mounting bracket (Stainless steel)
	/PM		Panel mounting bracket (Stainless steel)
Hood	/H3		Hood for sun protection (Carbon steel)
	/H4		Hood for sun protection (Stainless steel)
Tag Plate	/SCT		Stainless steel tag plate
Conduit Adapter	/AFTG		G 1/2
	/ANSI		1/2 NPT
Coating	/X1		Epoxy baked finish (*1)

*1: The housing is coated with epoxy resin.

*2: When CSA safe standard conformity product is needed, select 115V "-1" of Power Supply Voltage.

Control and Alarm Functions

Control output (mA)

: PI control on the 2nd mA output. The 2nd mA output can be configured to give a P/I (proportional and integral) control output. The setpoint, proportional band and integral time are each fully programmable.

- Adjustable parameters
 - : Setpoint, proportional range and integral time.

Process alarm : The contact will be switched when the process value reaches a limit. This can either be a high or low limit.

- Adjustable parameters
 - : Setpoint for the process value
 - Hysteresis of the switching action
 - Delay time of the relay (0 to 200 s)

PI duty cycle control (Fig. 5)

: The contact is used to control the time a solenoid valve is opened. The proportional control is achieved by opening and closing the solenoid valve and varying the ratio of on and off time (on, off).

- Adjustable parameters
 - : Setpoint, proportional range and integral time. Total period of the pulse period (5 to 100 s)

PI pulse frequency control (Fig. 6)

: The contact is used to control a pulse-driven pump. The frequency of pulses regulates the pump speed.

- Adjustable parameters
 - : Setpoint, proportional range & integral time. Maximum pulse frequency (50 to 120/min.)

Wash cleaning of sensors (Fig. 7)

: Contact S3 is used to control the wash cycle, or as a process alarm.

- Adjustable parameters
 - : Cleaning time or washing time (t_w)
 - Recovery time after washing (t_r)
 - Interval time for wash cycle.

The graph shows a typical response curve during washing. The wash and recovery times need to be set to suit the process.

Fault alarm : Contact S4 by default set to function as an alarm, indicating that the DO402G has found a fault in the measuring loop. If the self diagnostics of the DO402G indicate a fault or error, the FAIL contact will be switched. In most cases this will be caused by a malfunction of the measuring loop. The FAIL contact is also closed when the power is removed. The "FAIL" contact may also be configured as a fourth process alarm.

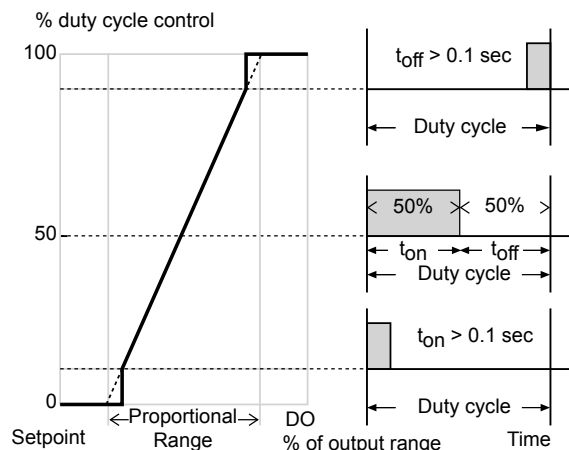

Fig. 5. Duty cycle control

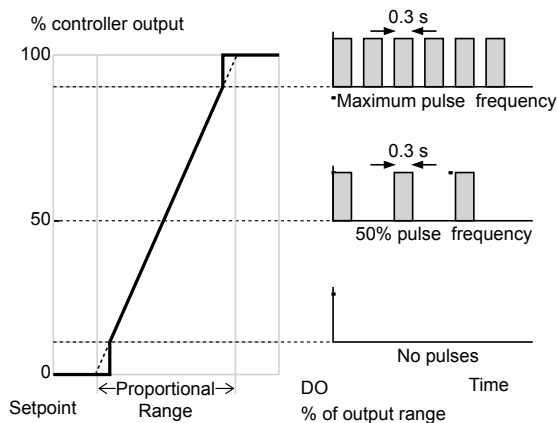

Fig. 6. Pulse frequency control

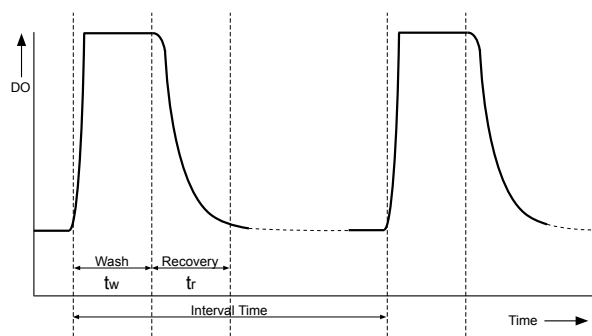
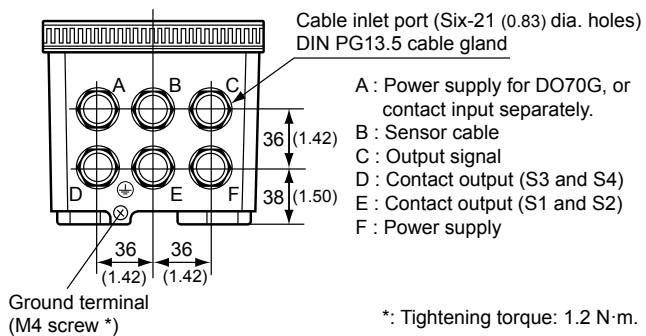
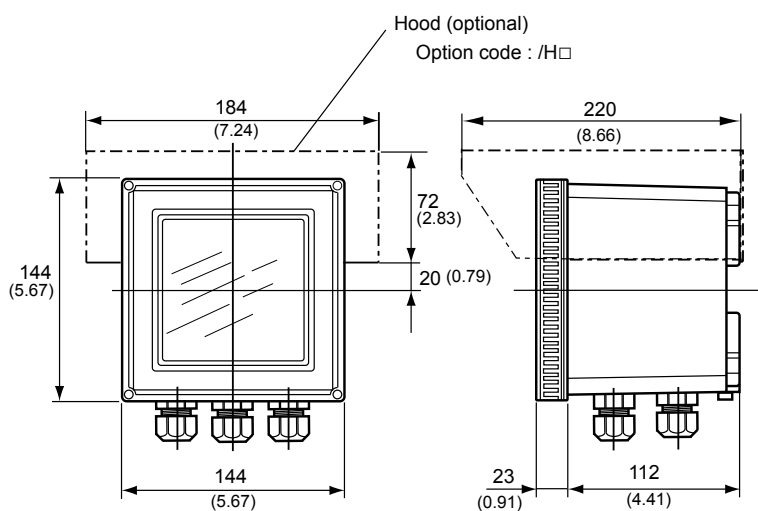

Fig. 7. Dynamic response during wash

External Dimensions

DO Converter DO402G



*: Tightening torque: 1.2 N·m.

Unit: mm (inch)

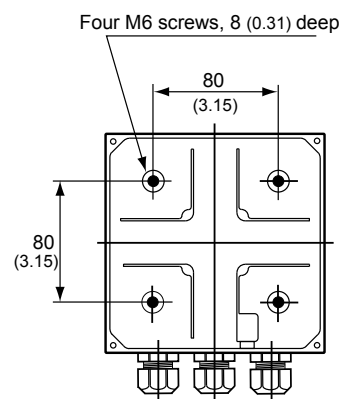

Adaptor for conduit work
(option code : /AFTG, /ANSI)

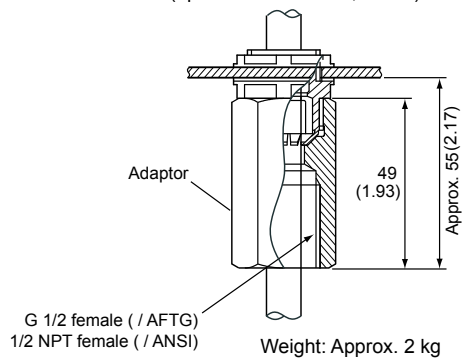

Pipe/Wall Mounting Brackets (Option Code: /U) Weight: approximately 0.7 kg

Example of bracket used for pipe mounting

Unit: mm (inch)

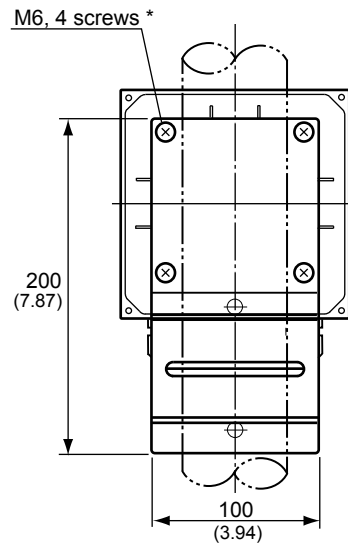
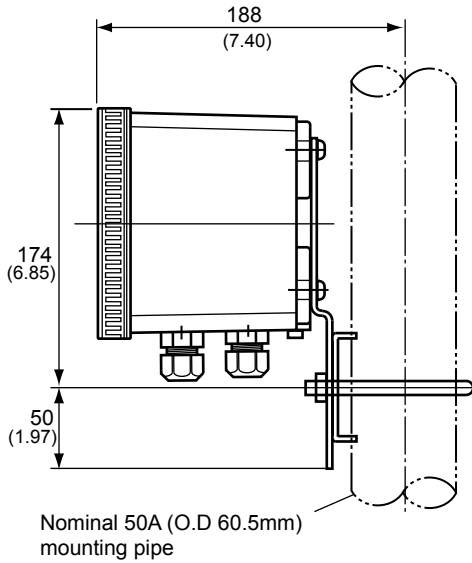

Example of bracket used for wall mounting

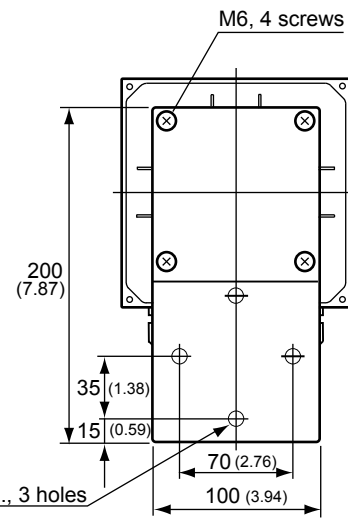
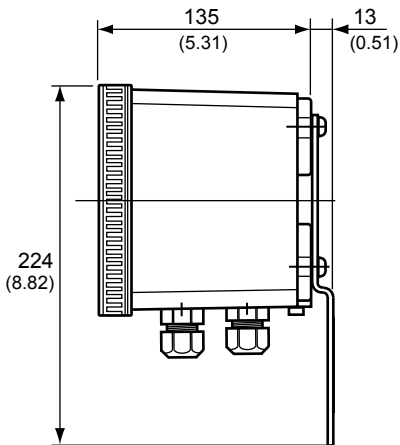

*: Tightening torque: 2 N·m.

F14-1.ai

Example of bracket used for panel mounting (Option Code: /PM) Weight: approximately 0.4 kg

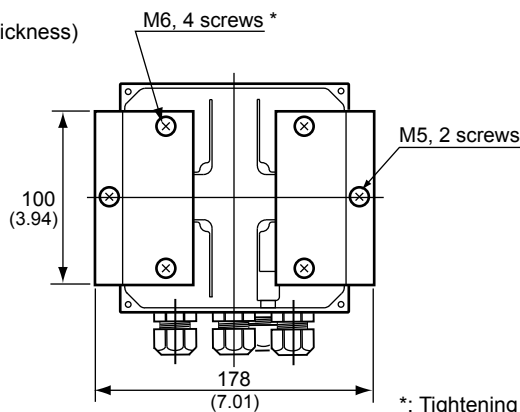
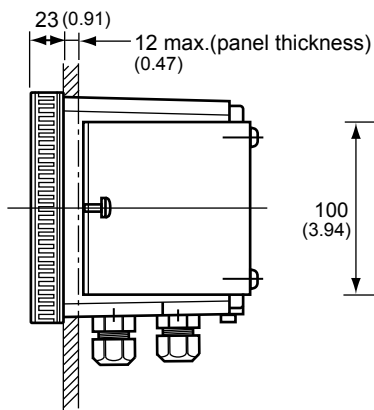

Panel cutout dimensions

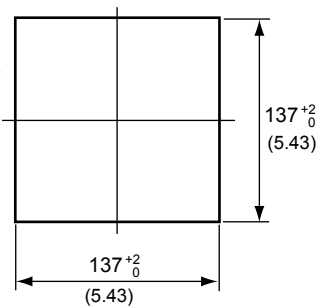

*: Tightening torque: 2 N·m.

F14-2.ai

System Configuration

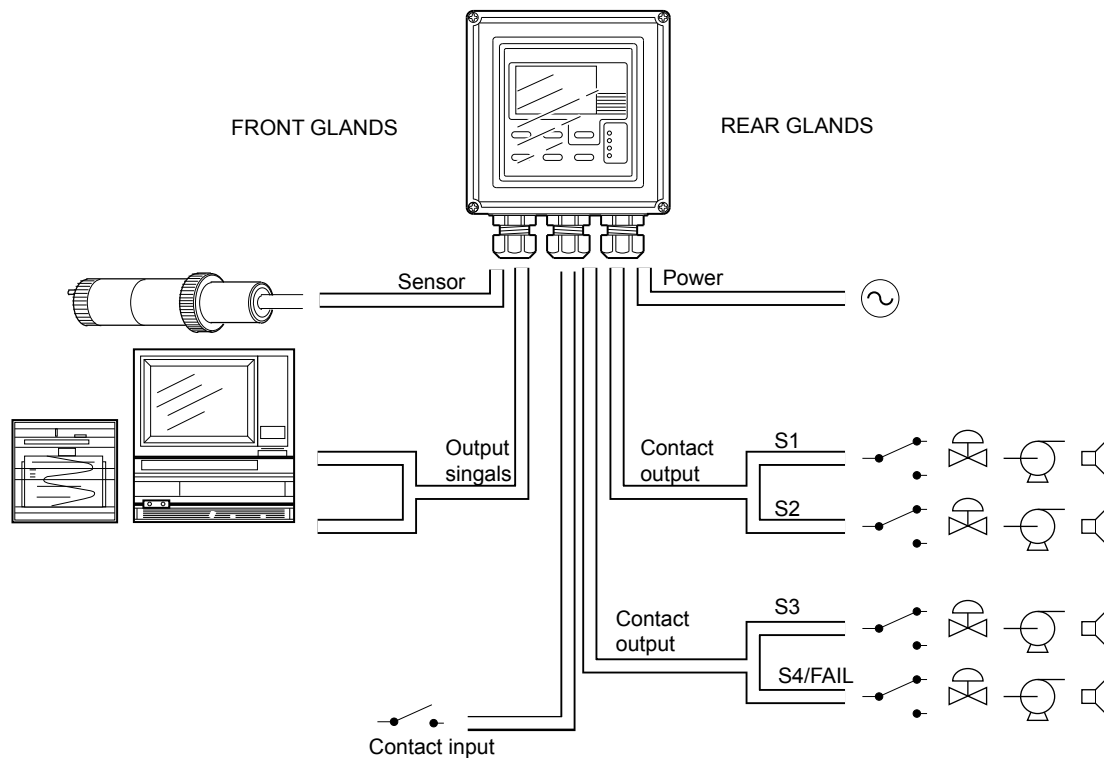

Input and Output Connections

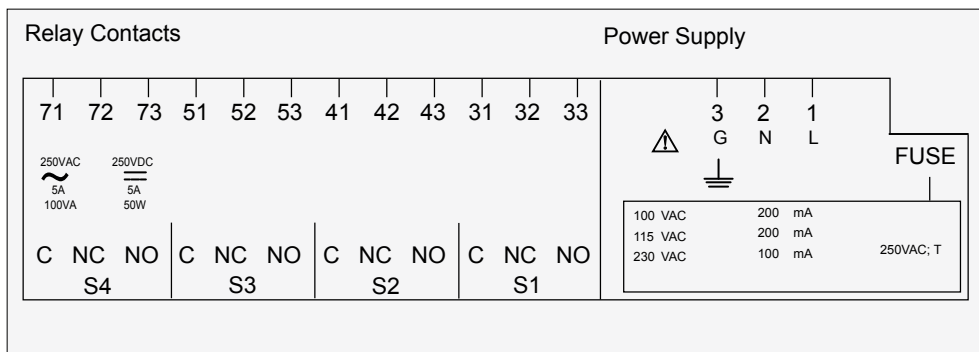
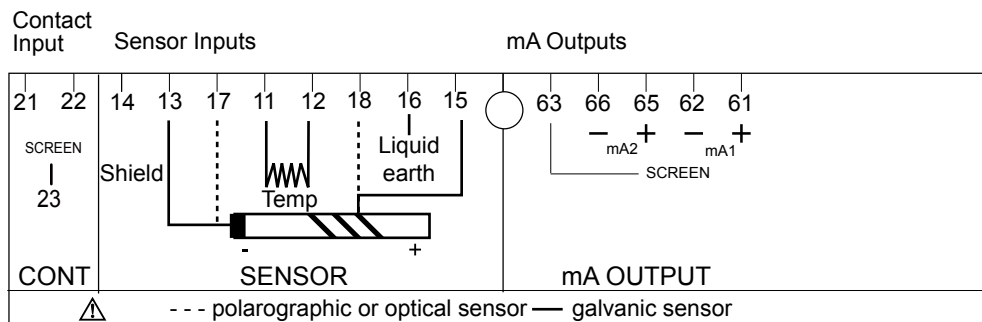

High voltage area

Inquiry Specifications Sheet for Dissolved Oxygen Analyzer

Make inquiries by placing checkmarks (✓) in the pertinent boxes and filling in the blanks.

1. General information

Name of your company: _____
 Name of inquirer: _____ Dept. or sect.: _____ (telephone: _____)
 Name of plant: _____
 Measuring point: _____
 Purpose of use: Indication Record Alarm Control
 Power supply: _____ V AC

2. Measuring conditions

(1) Liquid temperature: _____ to _____, normal _____ [°C]
 (2) Liquid pressure: _____ to _____, normal _____ [kPa]
 (3) Flow rate _____ to _____, normal _____ [m/s]
 (4) Name of liquid: _____
 (5) Composition of liquid: _____
 (6) Other remarks: _____

3. Installation environment

(1) Ambient temperature: _____
 (2) Location: Outdoors Indoors _____
 (3) Other remarks: _____

4. Specification requirements

(1) Measuring range: 0 to 50 mg/l, _____
 (2) Output signal: 4-20 mA DC, 0-20 mA DC
 (3) System component selection : Sensor Converter Power supply unit for DO70G Terminal box
 Holder Cleaning system Parts set for maintenance Calibration set
 (4) Length of sensor cable : 3 m 5 m 10 m 15 m 20 m
 (5) Type of holder : Guide pipe Submersion Floating ball Suspension
 (6) Cleaning method : No cleaning With jet cleaning
 (7) Other remarks: _____