

NOTE

This page may be referred to when reading pages where subsequent submenu screens are shown in the text. Connection to the relevant submenu screen is indicated by a dotted line with an arrow.

Note that screens in the text are typical examples and actual screens may differ depending on the set parameters.

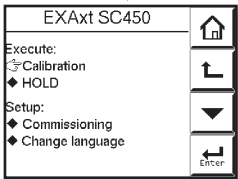
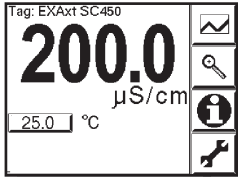

Commissioning

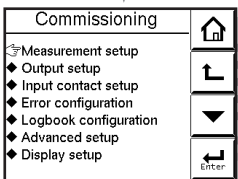

Connection to the relevant submenu screen is indicated by a dotted line with an arrow.

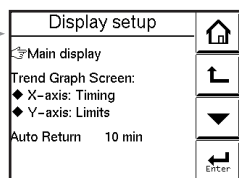
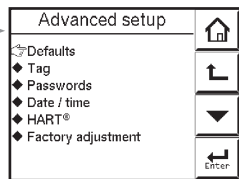
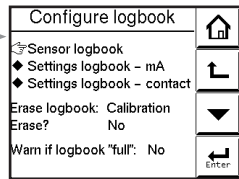
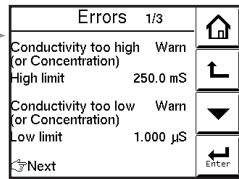
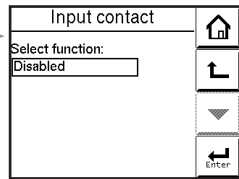
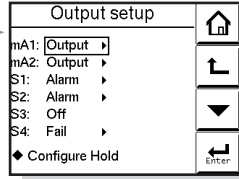
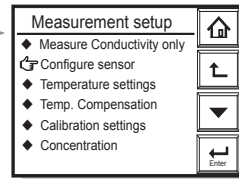
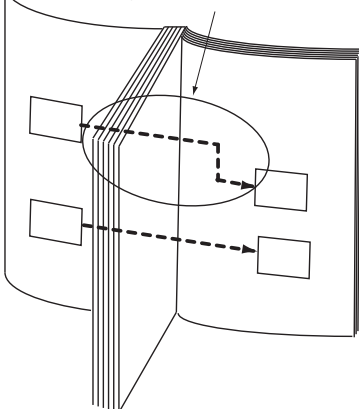

PREFACE

Thank you for purchasing the SC450G Conductivity Converter.

Please read the following respective documents before installing and using the SC450G Conductivity Converter.

The related documents are as follows.

General Specifications: GS 12D08N05-01E
User's Manual: IM 12D08N05-01E (this manual)

* the "E" in the document number is the language code.

An exclusive User's Manual might be attached to the products whose suffix codes or option codes contain the code "Z" (made to customers' specifications). Please read it along with this manual.

WARNING

Electrostatic discharge

The SC450G converter contains devices that can be damaged by electrostatic discharge.

When servicing this equipment, please observe proper procedures to prevent such damage.

Replacement components should be shipped in conductive packaging. Repair work should be done at grounded workstations using grounded soldering irons and wrist straps to avoid electrostatic discharge.

WARNING

Installation and wiring

The SC450G converter should only be used with equipment that meets the relevant IEC, American or Canadian standards. Yokogawa accepts no responsibility for the misuse of this unit.

CAUTION

The Instrument is packed carefully with shock absorbing materials, nevertheless, the instrument may be damaged or broken if subjected to strong shock, such as if the instrument is dropped. Handle with care.

 **CAUTION**

- Do not use an abrasive or organic solvent in cleaning the instrument.
- Do not modify the SC450G converter.
- Substitution of components may impair suitability for Division 2.
Do not remove or replace while circuit is live unless area is known to be non-hazardous.
Explosion Hazard – Do not disconnect equipment unless area is known to be nonhazardous.
Do not reset circuit breaker unless power has been removed from the equipment or the area is known to be non-hazardous.

■ Notice

- This manual should be passed on to the end user.
- The contents of this manual are subject to change without prior notice.
- The contents of this manual shall not be reproduced or copied, in part or in whole, without permission.
- This manual explains the functions contained in this product, but does not warrant that they are suitable the particular purpose of the user.
- Every effort has been made to ensure accuracy in the preparation of this manual. However, when you realize mistaken expressions or omissions, please contact the nearest Yokogawa Electric representative or sales office.
- This manual does not cover the special specifications. This manual may be left unchanged on any change of specification, construction or parts when the change does not affect the functions or performance of the product.
- If the product is not used in a manner specified in this manual, the safety of this product may be impaired.

Yokogawa is not responsible for damage to the instrument, poor performance of the instrument or losses resulting from such, if the problems are caused by:

- Improper operation by the user.
- Use of the instrument in improper applications
- Use of the instrument in an improper environment or improper utility program
- Repair or modification of the related instrument by an engineer not authorized by Yokogawa.

■ Safety and Modification Precautions

Follow the safety precautions in this manual when using the product to ensure protection and safety of the human body, the product and the system containing the product.

■ Warranty and service

Yokogawa products and parts are guaranteed free from defects in workmanship and material under normal use and service for a period of (typically) 12 months from the date of shipment from the manufacturer. Individual sales organizations can deviate from the typical warranty period, and the conditions of sale relating to the original purchase order should be consulted. Damage caused by wear and tear, inadequate maintenance, corrosion, or by the effects of chemical processes are excluded from this warranty coverage.

In the event of warranty claim, the defective goods should be sent (freight paid) to the service department of the relevant sales organization for repair or replacement (at Yokogawa discretion). The following information must be included in the letter accompanying the returned goods:

- Part number, model code and serial number
- Original purchase order and date
- Length of time in service and a description of the process
- Description of the fault, and the circumstances of failure
- Process/environmental conditions that may be related to the failure of the device.
- A statement whether warranty or non-warranty service is requested
- Complete shipping and billing instructions for return of material, plus the name and phone number of a contact person who can be reached for further information.

Returned goods that have been in contact with process fluids must be decontaminated/ disinfected before shipment. Goods should carry a certificate to this effect, for the health and safety of our employees. Material safety data sheets should also be included for all components of the processes to which the equipment has been exposed.

Safety Precautions

■ Safety, Protection, and Modification of the Product

- In order to protect the system controlled by the product and the product itself and ensure safe operation, observe the safety precautions described in this user's manual. We assume no liability for safety if users fail to observe these instructions when operating the product.
- If this instrument is used in a manner not specified in this user's manual, the protection provided by this instrument may be impaired.
- If any protection or safety circuit is required for the system controlled by the product or for the product itself, prepare it separately.
- Be sure to use the spare parts approved by Yokogawa Electric Corporation (hereafter simply referred to as YOKOGAWA) when replacing parts or consumables.
- Modification of the product is strictly prohibited.
- The following safety symbols are used on the product as well as in this manual.



WARNING

This symbol indicates that an operator must follow the instructions laid out in this manual in order to avoid the risks, for the human body, of injury, electric shock, or fatalities. The manual describes what special care the operator must take to avoid such risks.



CAUTION

This symbol indicates that the operator must refer to the instructions in this manual in order to prevent the instrument (hardware) or software from being damaged, or a system failure from occurring.

The following are signal words to be found only in our instruction manuals.

CAUTION

This symbol gives information essential for understanding the operations and functions.

NOTE

This symbol indicates information that complements the present topic.



This symbol indicates Protective Ground Terminal.



This symbol indicates Function Ground Terminal. Do not use this terminal as the protective ground terminal.



Alternating current



Direct current

■ Warning and Disclaimer

The product is provided on an "as is" basis. YOKOGAWA shall have neither liability nor responsibility to any person or entity with respect to any direct or indirect loss or damage arising from using the product or any defect of the product that YOKOGAWA can not predict in advance.

■ Notes on Handling User's Manuals

- Please hand over the user's manuals to your end users so that they can keep the user's manuals on hand for convenient reference.
- Please read the information thoroughly before using the product.
- The purpose of these user's manuals is not to warrant that the product is well suited to any particular purpose but rather to describe the functional details of the product.
- No part of the user's manuals may be transferred or reproduced without prior written consent from YOKOGAWA.
- YOKOGAWA reserves the right to make improvements in the user's manuals and product at any time, without notice or obligation.
- If you have any questions, or you find mistakes or omissions in the user's manuals, please contact our sales representative or your local distributor.

■ Drawing Conventions

Some drawings may be partially emphasized, simplified, or omitted, for the convenience of description.

Some screen images depicted in the user's manual may have different display positions or character types (e.g., the upper / lower case). Also note that some of the images contained in this user's manual are display examples.

■ Product Disposal

The instrument should be disposed of in accordance with local and national legislation/regulations.

■ Trademark Acknowledgments

- All other company and product names mentioned in this user's manual are trademarks or registered trademarks of their respective companies.
- We do not use TM or ® mark to indicate those trademarks or registered trademarks in this user's manual.

CE marking products

■ Authorized Representative in EEA

The Authorized Representative for this product in EEA is Yokogawa Europe B.V. (Euroweg 2, 3825 HD Amersfoort, The Netherlands).

■ Identification Tag

This manual and the identification tag attached on packing box are essential parts of the product.

Keep them together in a safe place for future reference.

■ Users

This product is designed to be used by a person with specialized knowledge.

■ How to dispose the batteries:

This is an explanation about the EU Battery Directive. This directive is only valid in the EU. Batteries are included in this product. Batteries incorporated into this product cannot be removed by yourself. Dispose them together with this product.

When you dispose this product in the EU, contact your local Yokogawa Europe B.V.office. Do not dispose them as domestic household waste.

Battery type: Manganese dioxide lithium battery



Notice: The symbol (see above) means they shall be sorted out and collected as ordained in the EU Battery Directive.

**Model SC450G
Conductivity Converter [Style: S2]**

IM 12D08N05-01E 6th Edition

CONTENTS

PREFACE..... i

Safety Precautions iv

CE marking products vi

1. INTRODUCTION AND GENERAL DESCRIPTION 1-1

 1.1 Instrument check 1-1

 1.2 Application..... 1-2

2. GENERAL SPECIFICATIONS 2-1

3. INSTALLATION AND WIRING 3-1

3.1 Installation and dimensions 3-1

 3.1.1 Installation site 3-1

 3.1.2 Mounting methods 3-1

3.2 Wiring 3-4

 3.2.1 Preparation 3-4

 3.2.2 Cables, Terminals, glands and conduit adapter 3-5

3.3 Wiring the power supply 3-7

 3.3.1 General precautions 3-7

 3.3.2 Access to terminal and cable entry 3-8

 3.3.3 AC power 3-8

 3.3.4 DC power 3-8

 3.3.5 Grounding the housing 3-9

 3.3.6 Switching on the instrument..... 3-9

3.4 Wiring the contact signals 3-10

 3.4.1 General precautions 3-10

 3.4.2 Contact outputs..... 3-10

 3.4.3 Contact input..... 3-11

3.5 Wiring the mA-output signals..... 3-11

 3.5.1 General precautions 3-11



 3.5.2 Analog output signals 3-11

3.6 Wiring the sensor system 3-11

 3.6.1 General precautions..... 3-11

 3.6.2 Sensor wiring 3-12

 3.6.3 Other sensor systems..... 3-12

3.6.4	Sensor cable connections using junction box (BA10) and extension cable (WF10).....	3-13
4.	OPERATION	4-1
4.1	Main display functions	4-1
4.2	Trending graphics 	4-1
4.3	Zoom in on details 	4-2
4.3.1	Actual mA1.....	4-2
4.3.2	Actual mA2.....	4-2
4.3.3	S1/S2/S3/S4	4-2
4.3.4	C.C. (factory).....	4-3
4.3.5	C.C. (adjusted).....	4-3
4.3.6	Temp. comp 1	4-3
4.3.7	Temp. comp 2	4-3
4.3.8	Polarization	4-3
4.3.9	Sensor ohms.....	4-3
4.3.10	Last calibrated at.....	4-3
4.3.11	Calibration due at.....	4-3
4.3.12	Projected calibration at	4-3
4.3.13	HART ID.....	4-4
4.3.14	Software revision	4-4
4.3.15	HART Device revision.....	4-4
4.3.16	Logbook	4-4
4.4	Information function	4-5
4.5	Setup-calibration & commissioning	4-5
4.6	Secondary-primary value display switch.....	4-5
4.7	Navigation of the menu structure	4-6
5.	MENU STRUCTURE COMMISSIONING	5-1
5.1	Configure sensor	5-1
5.2	Temperature setting.....	5-2
5.3	Temperature compensation.....	5-2
5.4	Calibration settings	5-4
5.5	Concentration.....	5-4
5.6	mA output setup.....	5-6
5.7	Contact output setup.....	5-10
5.8	Fail	5-12
5.9	Simulate	5-14
5.10	Water for Injection Monitoring (USP 645 and EU 0169)	5-14
5.11	Input contacts.....	5-16

5.12	Error configuration	5-16
5.13	Logbook configuration.....	5-18
5.14	Advanced setup	5-18
5.15	Display setup.....	5-19
6.	CALIBRATION	6-1
6.1	Cell constant manual.....	6-1
6.2	Cell constant automatic	6-1
6.3	Air (zero) calibration	6-1
6.4	Sample calibration.....	6-2
6.5	Temperature coefficient calibration.....	6-2
6.6	Temperature calibration	6-2
6.7	Operation of hold function during calibration.....	6-2
6.8	General comments on SC calibration.....	6-2
7.	MAINTENANCE	7-1
7.1	Periodic maintenance.....	7-1
7.2	Periodic maintenance of the sensor	7-1
7.3	Cleaning methods.....	7-2
7.4	LCD adjustment	7-2
8.	TROUBLESHOOTING.....	8-1
8.1	Calibration check.....	8-1
8.2	Polarization check	8-1
8.3	Predictive maintenance.....	8-2
8.4	Prediction of cleaning needed.....	8-2
8.5	Poor calibration technique	8-2
8.6	Error displays and actions.....	8-2
APPENDICES	APP-1	
Appendix 1	Temperature compensation	APP-1
Appendix 2	TDS readings	APP-5
Appendix 3	Calibration solutions for conductivity	APP-5
Appendix 4	Sensor selection for the SC450G	APP-7
Appendix 5	How to enter the cell constant for the SC21□G, SC8SG, and SC4AJ	APP-9
Appendix 6	HART HHT (275/375) menu structure	APP-9
Appendix 7	Control drawing for FM approval.....	APP-13
Customer Maintenance Parts List.....	CMPL 12D08N05-02E	
Revision Record	i	

Blank Page

1. INTRODUCTION AND GENERAL DESCRIPTION

The Yokogawa SC450G is a converter designed for industrial process monitoring, measurement and control applications. This instruction manual contains the information needed to install, set up, operate and maintain the unit correctly. This manual also includes a basic troubleshooting guide to answer typical user questions.

Yokogawa can not be responsible for the performance of the SC450G converter if these instructions are not followed.

1.1 Instrument check

Upon delivery, unpack the instrument carefully and inspect it to ensure that it was not damaged during shipment. If damage is found, retain the original packing materials (including the outer box) and then immediately notify the carrier and the relevant Yokogawa sales office.

Make sure the model number on the nameplate affixed to the side of the instrument agrees with your order. Example of the nameplate is shown below.

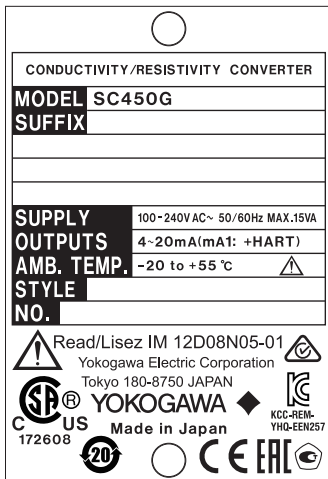

Figure 1.1 Nameplate

NOTE

- The nameplate will also contain the serial number and any relevant certification marks. Be sure to apply correct power to the unit, as detailed on the nameplate.
- Refer to “Control drawing for FM approval” of Appendix 4 in case of Option code is “-U (FM version)” of Model and Suffix Codes.
- When contact output current is more than 4 Amps. ambient temperature should be less than 40°C.

1.2 Application

The SC450G converter is intended to be used for continuous on-line measurement of Conductivity, Resistivity and/or Concentration in industrial installations. The unit combines simple operation and microprocessor-based performance with advanced self-diagnostics and enhanced communications capability to meet the most advanced requirements. The measurement can be used as part of an automated process control system. It can also be used to indicate operating limits of a process, to monitor product quality, or to function as a controller for a dosing/dilution system.

Sensors should normally be mounted close to the converter in order to ensure easy calibration and peak performance. If the unit must be mounted remotely from the sensors, WF10 extension cable can be used, up to a maximum of 50 metres (150 feet), with a BA10 junction box, and up to 10 metres standard sensor cable.

The SC450G is delivered with a general purpose default setting for programmable items (see Chapter 5). While this initial configuration allows easy start-up, the configuration should be adjusted to suit each particular application. An example of an adjustable item is the type of temperature sensor used. The SC450G can be adjusted for a number of different types of temperature sensors.

Details provided in this instruction manual are sufficient to operate the SC450G with all Yokogawa sensor systems and a wide range of third-party commercially available probes. For best results, read this manual in conjunction with the corresponding sensor instruction manual.

Yokogawa designed the SC450G converter to withstand industrial environments. It meets all the CE regulatory standards. The unit meets or exceeds stringent requirements (see Chapter 2) without compromise, to assure the user of continued accurate performance in even the most demanding industrial installations.

2. GENERAL SPECIFICATIONS

Input specifications:

Two or four electrodes measurement with square wave excitation, using max 60m (200 ft) cable (WU40/WF10) and cell constants from 0.005 to 50.0 cm⁻¹

Input ranges:

Conductivity: 0.000 μ S/cm to 2000 mS/cm
 Minimum: 1 μ S/cm (underrange 0.00 μ S x C)
 Maximum: 200 mS/cm (overrange 2000 mS x C)

Resistivity: 0.0 Ω x cm to 1000 M Ω x cm
 Minimum: 5 Ω /cm (underrange 0.0 Ω /C)
 Maximum: 1 M Ω /cm (overrange 1000 M Ω /C)

Note: "C" means cell constant.

Temperature:	Pt1000	-20 to 250°C (0 to 500°F)
	Pt100	-20 to 200°C (0 to 400°F)
	Ni100	-20 to 200°C (0 to 400°F)
	NTC 8k55	-10 to 120°C (10 to 250°F)
	Pb36 (JIS NTC 6k)	-20 to 120°C (0 to 250°F)

Accuracy:

Conductivity/resistivity:	≤ 0.5% of reading
Temperature:	≤ 0.3°C (≤ 0.4°C for Pt100)
Step response:	≤ 4 seconds for 90% (for a 2 decade step)

Note on performance specifications

The following tolerance is added to above performance.

mA output tolerance: ±0.02 mA of "4-20 mA"

Transmission signals:

General;	Two isolated outputs of 4-20 mA. DC with common negative. Maximum load 600 Ω . Bi-directional HART® (HART 5) digital communication, superimposed on mA1 (4-20 mA) signal.
Output function;	Linear or 21-step table for Conductivity/Resistivity, Concentration or Temperature.
Control function;	PID control
Burn out function;	Burn up (21.0 mA) or burn down (3.6 mA) to signal failure acc. NAMUR NE43.
Parameters;	Adjustable damping Expire time
Hold;	The mA-outputs are frozen to the last/fixed value during calibration/commissioning.

Contact outputs:

General;	Four SPDT relay contacts with display indicators. Contact outputs configurable for hysteresis and delay time.
Switch capacity;	Maximum values 100 VA, 250 V AC, 5 Amps. (*1) Maximum values 50 Watts, 250 V DC, 5 Amps. (*1)
Status;	High/Low process alarms, selected from conductivity, resistivity, concentration or temperature. Configurable delay time and hysteresis. PID duty cycle or pulsed frequency control. FAIL alarm

Control function;	On/Off Adjustable damping Expire time
Hold;	Contact can be used to signal the Hold situation.
Fail safe;	Contact S4 is programmed as failsafe contact.
*1:	When contact output current is more than 4 Amps, ambient temperature should be less than 40 °C.

Contact input:

Remote range switching to 10 times the programmed range.

Contact open;	If impedance > 100 kΩ: 1 x Range (When programmed range for mA output is conductivity).
Contact closed;	If impedance < 10 Ω: 10 x Range

Temperature compensation:

Function;	Automatic or manual, for temperature ranges mentioned under B (inputs).
Reference temp.;	programmable from 0 to 100°C or 30 to 210 °F (default 25°C).

Compensation algorithm:

According IEC 60746-3 NaCl tables (default). Two independent user programmable temperature coefficients, from 0% to 3.5% per °C (°F) by adjustment or calibration.

Matrix compensation:	With conductivity function of concentration and temperature. Choice out of 13 preprogrammed matrixes and 2 100-points user-programmable matrixes.
----------------------	---

Calibration:

Semi-automatic calibration using pre-configured OIML (KCl) stanard tables, with automatic stability check. Manual adjustment to grab sample.

Logbook:

Software record of important events and diagnostic data readily available in the display or through HART®.

Display:

Graphical Quarter VGA (320 x 240 pixels) LCD with LED backlight and touchscreen. Plain language messages in English, German, French, Spanish, Italian, Swedish, Portuguese and Japanese.

Form:

Dimension;	144 (W) x 144 (H) x Approx.144 (D) mm
Converter weight;	Approx. 1.5 kg

Housing:

Cast Aluminum housing with chemically resistant coating;
Polycarbonate cover with Polycarbonate flexible window
Protection IP66 / NEMA 4X / CSA Type 3S

Colour;	Silver grey
SC450G-A(D)-A:	IP66 cable glands are supplied with the unit
SC450G-A(D)-U:	NEMA 4X close up plugs are mounted in the unused cable entry holes and can be replaced by conduit fittings as required Pipe, Panel or Wall mounting using optional hardware
Optional conduit adapter;	G1/2, 1/2NPT or M20 female

Power supply:

SC450G-A:

Ratings; 100-240 V AC
 Acceptable range; 90 to 264 V AC
 Ratings; 50/60 Hz
 Acceptable range; 50 Hz $\pm 5\%$, 60 Hz $\pm 5\%$
 Power Consumption; 15 VA

SC450G-D:

Ratings; 12-24 V DC
 Acceptable range; 10.8 to 26.4 V DC
 Power Consumption; 10 W

Safety, EMC and RoHS conforming standards

Safety: EN 61010-1
 EN 61010-2-030
 EN 61010-2-201
 CAN/CSA C22.2 No.61010-1
 CAN/CSA C22.2 No.61010-2-030
 CAN/CSA IEC 61010-2-201
 UL 61010-1
 UL 61010-2-030
 UL 61010-2-201

EMC: EN 61326-1 Class A, Table 2 *1
 EN 61326-2-3
 EN 61000-3-2 Class A
 EN 61000-3-3

RCM: EN61326-1 Class A
 Korea Electromagnetic Conformity Standard

*1: Influence of immunity environment (Criteria A): Output shift is specified within $\pm 35\%$ of F.S.

Note: This instrument is a Class A product, and it is designed for use in the industrial environment. Please use this instrument in the industrial environment only.

RoHS: EN 50581

FM nonincendive approval (suffix code Type: -U):

FM3611 Class I, Div.2, Group ABCD, T6 for Ta -20 to 55°C

Installation altitude: 2000 m or less

Category based on IEC 61010: II (Note)

Pollution degree based on IEC 61010: 2 (Note)

Note: Installation category, called over-voltage category, specifies impulse withstand voltage. Category II is for electrical equipment. Pollution degree indicates the degree of existence of solid, liquid, gas or other inclusions which may reduce dielectric strength. Degree 2 is the normal indoor environment.

Environment and operational conditions:

Ambient temperature; -20 to +55°C

Storage temperature; -30 to +70°C

Humidity; 10 to 90% RH (non-condensing)

Data protection; EEPROM for configuration data and logbook. Lithium cell for clock.

Watchdog timer; Checks microprocessor

Power down; Reset to measurement.

Automatic safeguard; Auto return to measuring mode when touchscreen is untouched for 10 min.

Model and Suffix Codes

[Style: S2]

Model	Suffix code	Option code	Description
SC450G	-----	-----	Conductivity Converter
Power	- A	-----	AC version (100...240 VAC)
	- D	-----	DC version (12...24 VDC)
Type	- A	-----	General purpose version
	- U	-----	FM version (*3)
Mounting Hardware	/UM		Universal mounting kit (panel, pipe, wall)
	/U		Pipe and wall mounting hardware (*2)
	/PM		Panel mounting hardware (*2)
Hood	/H5		Awning hood (stainless steel) (*2)
Conduit adapter	/AFTG		G1/2 (*2)
	/ANSI		1/2NPT (*2)
	/AM20		M20 (*2)
Tag Plate	/SCT		Stainless steel tag plate (*1)

Notes: *1 If the tag number is predefined with the purchase, Yokogawa will inscript the tag plate with the specified tag number, and program the tag number in the converter.

*2 Option codes /U, /PM, /H5, /AFTG, /ANSI and /AM20 are not specified for FM version (-U).

*3 Nonincendive for FM only.

3. INSTALLATION AND WIRING

3.1 Installation and dimensions

3.1.1 Installation site

The SC450G converter is weatherproof and can be installed inside or outside. It should, however, be installed as close as possible to the sensor to avoid long cable runs between sensor and converter. In any case, the cable length should not exceed 60 metres (197 feet).

Select an installation site where:

- Mechanical vibrations and shocks are negligible
- No relay/power switches are in the direct environment
- Access is possible to the cable glands (see figure 3.1)
- The converter is not mounted in direct sunlight or severe weather conditions
- Maintenance procedures are possible (avoiding corrosive environments)

The ambient temperature and humidity of the installation environment must be within the limits of the instrument specifications. (See chapter 2).

3.1.2 Mounting methods

Refer to figures 3.2 and 3.3. Note that the SC450G converter has universal mounting capabilities:

- Panel mounting using optional brackets
- Surface mounting on a plate (using bolts from the back)
- Wall mounting on a bracket (for example, on a solid wall)
- Pipe mounting using a bracket on a horizontal or vertical pipe Size nominal 50A

Unit: mm (inch)

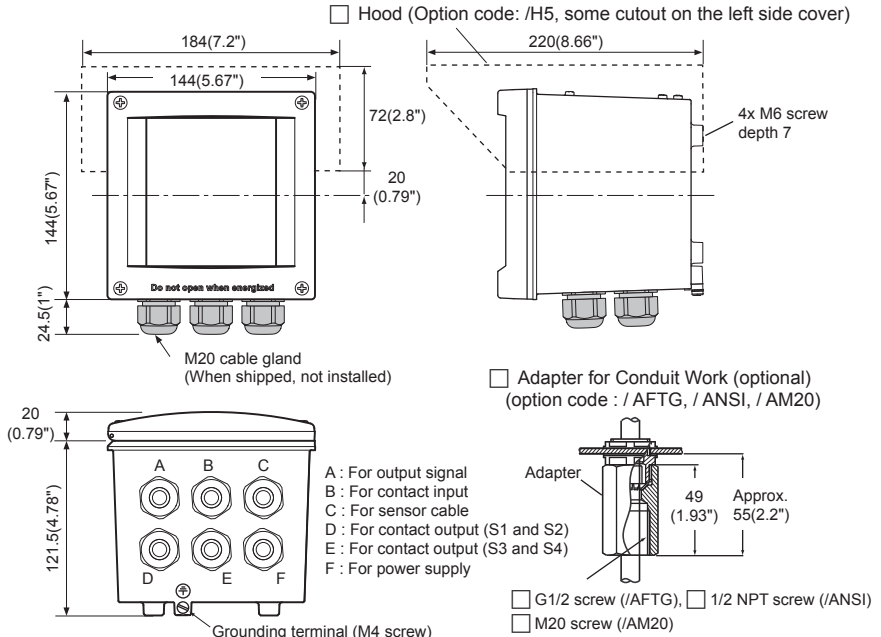

Figure 3.1 Housing dimensions and layout of glands

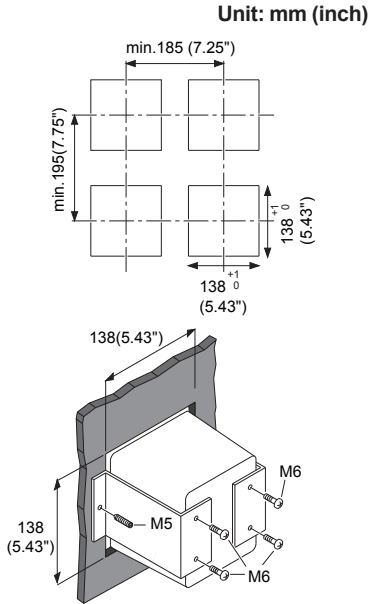

Figure 3.2 Option /PM: panel mounting diagram

Note: When option code “/UM” is specified, universal pipe/wall/panel mounting kit are supplied---same as option code “/U” and “/PM” both specified.

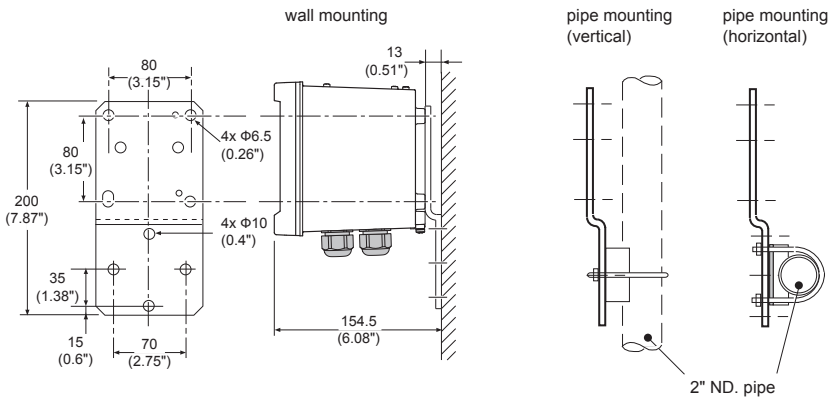
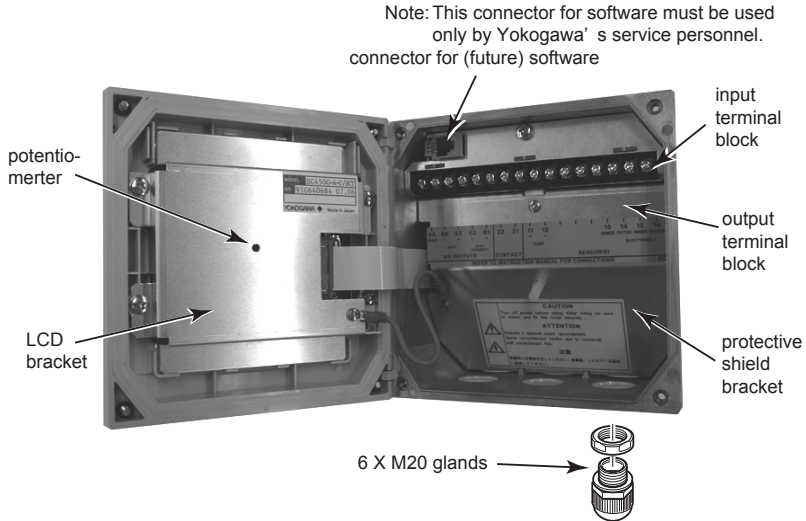

Figure 3.3 Option /U: wall and pipe mounting diagram

**Note: SC450G-A(D)-U**

The enclosure is provided with stoppers instead of M20 cable glands for the unused holes. These stoppers must be removed and replaced by FM approved conduit fittings in accordance with good installation practice. Also see Appendix 7, Control drawing for FM approval.

Figure 3.4 Internal view of SC450G wiring compartment

3.2 Wiring

3.2.1 Preparation

Refer to figure 3.4. The relay contact terminals and power supply connections are under the screening (shielding) plate. These should be connected first. Connect the sensor, outputs and HART® communication connections last.

To open the SC450G for wiring:

1. Loosen the four front plate screws and swing open the cover.
2. The upper terminal strip is now visible.
3. Remove the screen (shield) plate covering the lower terminal strip.
4. Connect the power supply and contact outputs. Use the three glands at the back for these cables.

WARNING

- Cables that withstand temperatures of at least 75 °C should be used for wiring.
- Wiring work should be performed to meet IP66 or higher requirements. Tighten four front plate screws to 1.5 N·m torque.
- Use cables that comply with UL2556VW-1 or equivalent.

 **WARNING**

Always place the screen plate over the power supply and contact terminals for safety reasons and to avoid interference.

5. Put back (replace) the screen (shield) plate over the lower terminals.
6. Connect the analog output(s), the sensor inputs, and, if necessary, the HART® wiring and input contact.
7. Use the front three glands for analog output, sensor inputs, contact input and HART® wiring (see figure 3.5).
8. Swing back the cover and secure it with the four screws.
9. Switch on the power. Commission the instrument as required or use the default settings.

 **CAUTION**

Do not turn on power with the touchscreen pressed, otherwise inaccurate screen positioning will occur. If it occurs, leave the touchscreen unpressed, turn off power then on again. The screen positioning will be accurate.

3.2.2 Cables, Terminals, glands and conduit adapter

SC450G-A(D)-A

The SC450G is supplied with terminals suitable for the connection of finished wires in the size range of 0.13 to 2.5 sq.mm. (26 to 14 AWG). The cable glands supplied will form a tight seal on cables with an outside diameter of 6 to 12 mm (0.24 to 0.47 inches). Unused cable entry holes must be sealed with cable glands including the close up plugs supplied.

SC450G-A(D)-U

The SC450G is supplied with terminals suitable for the connection of finished wires in the size range of 14- 26 AWG. The cable entry holes are sealed with FM certified plugs. Prior to cable entry the plugs can be removed with allen key size 3/8". The cable conduit fittings can be mounted in the holes of the housing as required. The cable glands supplied with the unit will give a tight seal on cables with outside diameter of 0.24 to 0.47 inches.

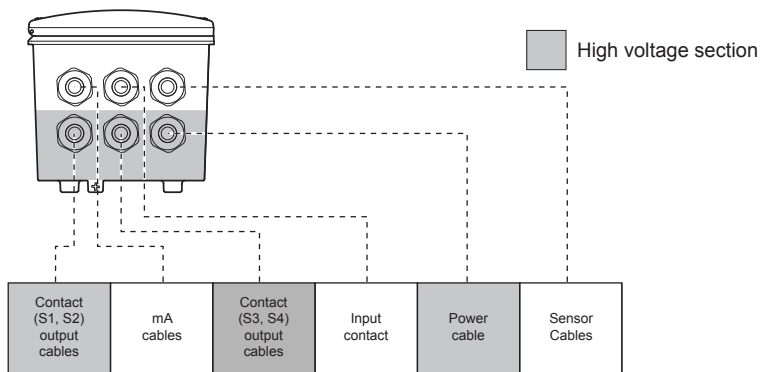

Suitable for cables with an outside diameter between 6 - 12 mm (0.24 - 0.47")

Figure 3.5a Cable glands diagram

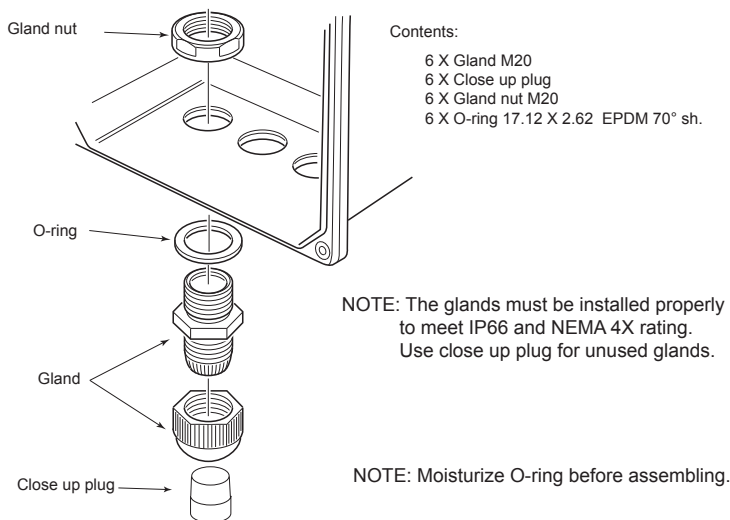

Figure 3.5b How to install cable glands

● **Adapter for conduit work**

When protect the cable with a conduit, replace the M20 cable gland with a cable gland of optional conduit adapter, and set the adapter shown as Figure 3.5c.

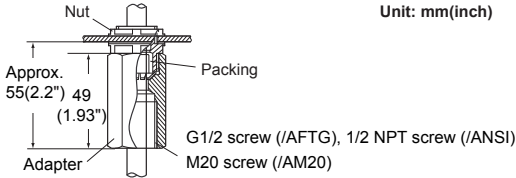

Figure 3.5c Conduit adapter

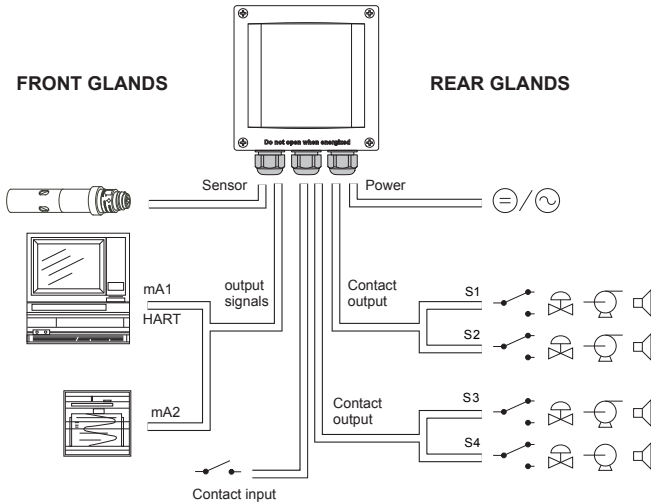

Figure 3.6 System configuration

3.3 Wiring the power supply

3.3.1 General precautions

NOTE

Make sure the power supply is switched off. Also, make sure that the power supply is correct for the specifications of the SC450G and that the supply agrees with the voltage specified on the textplate.

WARNING

- Install an external switch or circuit breaker to the power supply of the converter.
- Use an external switch or circuit breaker rated 5A and conforming to IEC 60947-1 or IEC 60947-3.
- It is recommended that the external switch or circuit breaker be installed in the same room as the converter.
- The external switch or circuit breaker should be installed within reach of the operator and identified with marking as a power supply switch to the converter.
- Power lines such as power cables and contact outputs should be fixed securely onto a wall or construction using cable racks, conduit tubing, nylon bands or other appropriate ways. Accidental removal from terminals by pulling may result in electric shock.

Local health and safety regulations may require an external circuit breaker to be installed. The instrument is protected internally by a fuse. The fuse rating is dependent on the supply to the instrument. The 250 VAC fuses should be of the "time-lag" type, conforming to IEC127.

WARNING

Fuse replacement should be performed only by a qualified service personnel. See Chapter 7. MAINTENANCE, Fuse.

Fuse ratings:

Power supply	Fuse type
12-24 VDC, 10W max	2A/250V, Slow
100-240 VAC, 15VA max	0.5A/250V, Slow

3.3.2 Access to terminal and cable entry

Terminals 1 and 2 are used for the power supply.

Guide the power cables through the gland closed to the power supply terminals. The terminals will accept wires of 2.5 mm² (14 AWG). Always use cable finishings if possible.

3.3.3 AC power

Connect terminal L to the phase line of the AC power and terminal N to the zero line. See figure 3.8 for the power ground. This is separated from input ground by a galvanic isolation. Should be used the cable beyond 300 V AC.

3.3.4 DC power

Connect terminal 1 to the positive outlet and terminal 2 to the negative outlet.

Should be used the cable beyond 30 V AC.

This is separated from input ground by a galvanic isolation. The size of conductors should be at least 1.25 mm². The overall cable diameter should be between 6 and 12 mm.

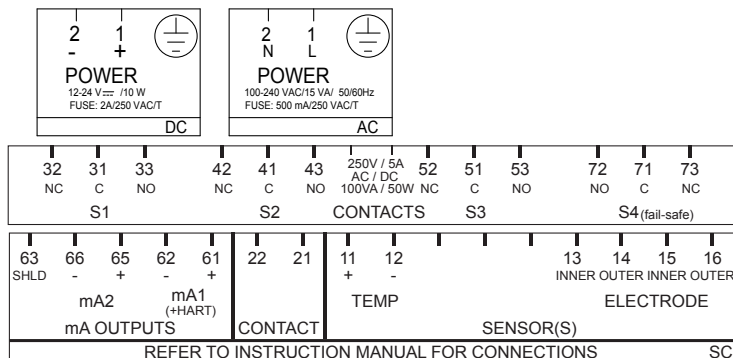

Figure 3.7 Input and output connections

3.3.5 Grounding the housing

NOTE

For the safety of the user and to protect the instrument against interference, the housing must always be connected to ground. This has to be done by a large area conductor. This cable can be fixed to the rear of the housing or by using the internal ground connections using a braided wire cable. See figure 3.8.

 **WARNING**

The minimum cross sectional area of the protective grounding wire should be 0.75 mm².

3.3.6 Switching on the instrument

After all connections are made and checked, the power can be switched on from the power supply. Make sure the LCD display comes on.

After a brief interval, the display will change to the measured value. If errors are displayed or a valid measured value is not shown, consult the troubleshooting section (Chapter 8) before calling Yokogawa.

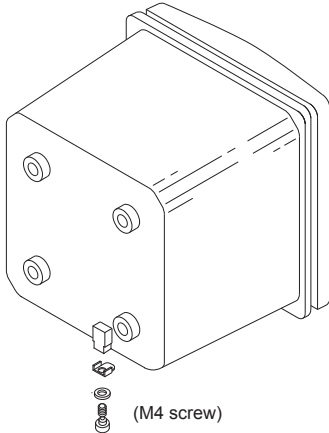

Figure 3.8a External grounding

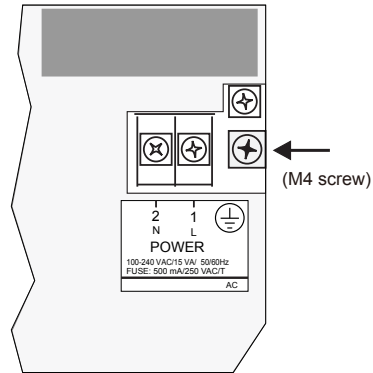

Figure 3.8b Internal grounding

3.4 Wiring the contact signals

3.4.1 General precautions

The contact output signals consist of voltage-free relay contacts for switching electrical appliances (SPDT). They can also be used as digital outputs to signal processing equipment (such as a controller or PLC). It is possible to use multi-core cables for the contact in and output signals and shielded multi-core cable for the analog signals.

3.4.2 Contact outputs

The SC450G unit's four contacts (switches) that can be wired and configured to suit user requirements. Contact S4 is programmed as a fail-safe contact. Please refer to section 5.7, Contact output setup for functionality description.

- **Alarm (limits monitoring)**

Contacts configured as "ALARM" can be energized when limits are crossed.

- **Fail**

Contacts configured as "FAIL" will be energized when a fail situation occurs. Some fail situations are automatically signaled by the internal diagnostics (electronics) of the converter. Others can be configured by the user (see section 5.12 Error Configuration). By pressing the "INFO" button on the main screen the user is given an explanation as well as a remedy for the current fail situation.

Always connect the fail contact to an alarm device such as a warning light, alarm bell or displayed on an annunciator.

	“ALARM” Contact	“FAIL” Contact
Power Off	NC	NC
Power On	NC	NC
Alarm	NO	NC
Fail	NC	NO
Fail and Alarm	NC *	NO
HOLD	NC	NC

* When a fail situation occurs which is related to the parameter associated with the contact (Conductivity, Concentration or temperature) the contact will go to NC. When the fail situation is not related to the parameter associated with the contact the contact will remain in the state it is currently in.

Be beyond 300 V AC and please use a cable of the electric current capacity according to the load connected to contact output.

3.4.3 Contact input

It is necessary to use screening/shielding on the input signal cables. Terminal 63 is used to connect the shielding.

3.5 Wiring the mA-output signals

3.5.1 General precautions

The analog output signals of the SC450G transmit low power standard industry signals to peripherals like control systems or strip-chart recorders (Figure 3.6).

3.5.2 Analog output signals

The output signals consist of active current signals of 4-20 mA. The maximum load can be 600 ohms on each. Should be used the cable beyond 30 V AC.

It is necessary to use screening/shielding on the output signal cables. Terminal 63 is used to connect the shielding.

3.6 Wiring the sensor system

3.6.1 General precautions

Generally, signals from sensors are at low voltage and current level. Thus a lot of care must be taken to avoid interference. Before connecting sensor cables to the converter make sure that following conditions are met:

- the sensor cables are not mounted in tracks together with high voltage and or power switching cables
- only standard sensor cable or extension cable is used
- the converter is mounted within the distance of the sensor cables (max. 10 m) + up to 60m WF10 extension cable.
- the setup is kept flexible at the sensors end for easy insertion and retraction of the sensor in the fitting.

3.6.2 Sensor wiring

Refer to figure 3-9, which includes drawings that outline sensor wiring.

The SC450G can be used with a wide range of sensor types. The sensor system fall into two categories, the ones that use fixed cables and the ones with separate cables.

To connect sensors with fixed cables, simply match the terminal numbers in the instrument with the identification numbers on the cable ends.

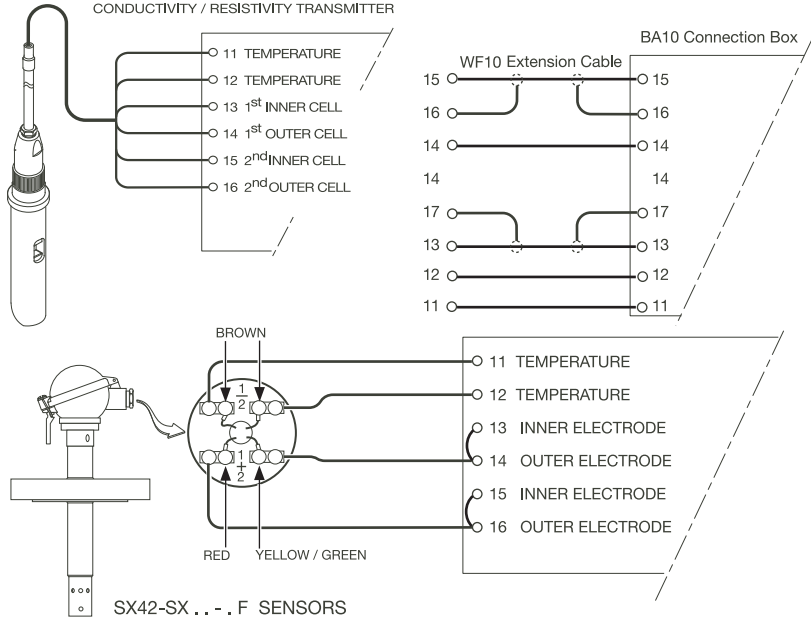

Figure 3.9 Sensor wiring diagrams

3.6.3 Other sensor systems

To connect other sensor systems, follow the general pattern of the terminal connections as listed below:

- 11 and 12: Always used for temperature compensation resistor input.
- 13 and 14: Normally used for the outer electrode
- 15 and 16: Used for inner electrode

In case a 4-electrode measuring system will be used, 14 and 16 should be used for the current electrodes. Please ensure that shielded cabling will be used.

In below figure this is shown in a schematic way.

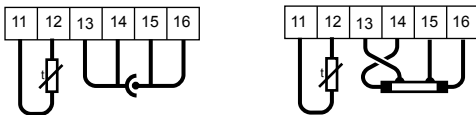

3.6.4 Sensor cable connections using junction box (BA10) and extension cable (WF10)

Where a convenient installation is not possible using the standard cables between sensors and converter, a junction box and extension cable may be used. The Yokogawa BA10 junction box and the WF10 extension cable should be used. These items are manufactured to a very high standard and are necessary to ensure that the specifications of the system can be met.

The total cable length should not exceed 60 metres (e.g. 5 m fixed cable and 55 m extension cable).

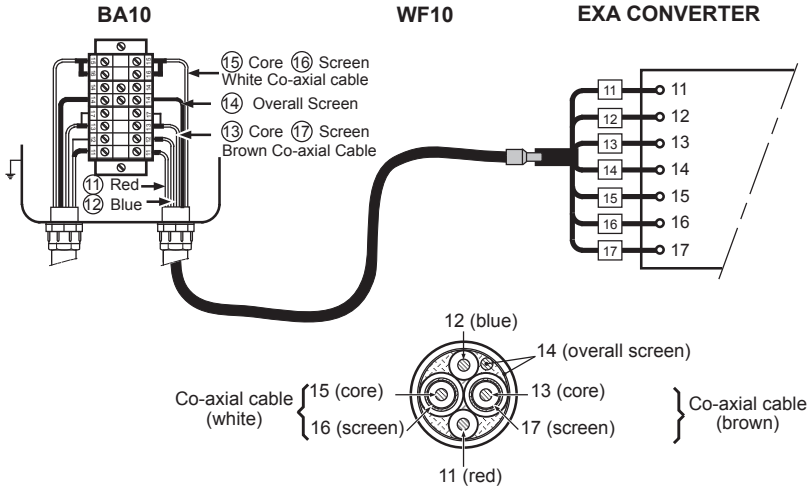

Figure 3.10 Connection of WF10 extension cable and BA10 junction box

Extension cable may be purchased in bulk quantities or in pre-finished lengths. In the case of bulk quantities cut to length, then it is necessary to terminate the cable as shown below. Termination procedure for WF10 cable.

1. Slide 3 cm of heat shrink tube (9 x 1.5) over the cable end to be terminated.
2. Strip 9 cm of the outer (black) insulating material, taking care not to cut or damage internal cores.
3. Remove loose copper screening, and cut off the cotton packing threads as short as possible.
4. Strip insulation from the last 3 cm of the brown, and the white coaxial cores.
5. Extract the coaxial cores from the braid, and trim off the black (low-noise) screening material as short as possible.
6. Insulate the overall screen and the 2 coaxial screens with suitable plastic tubing.
7. Strip and terminate all ends with suitable (crimp) terminals and identify with numbers as shown.
8. Finally shrink the overall heat shrink tube into position.

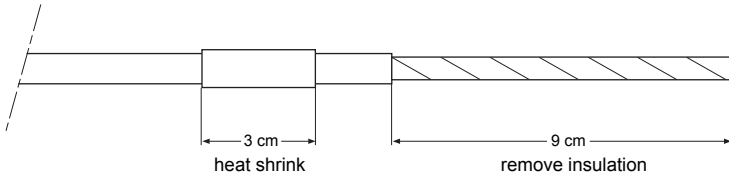

Figure 3.11a

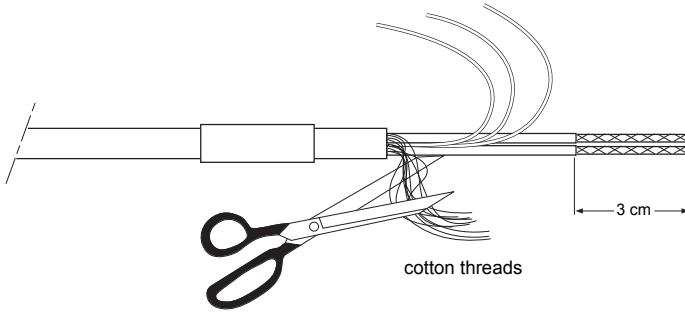

Figure 3.11b

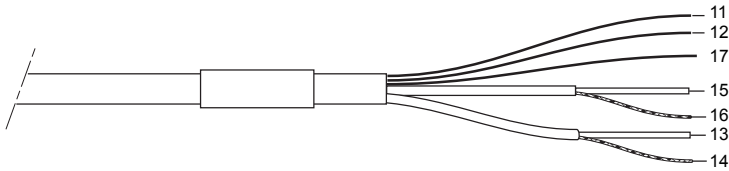

Figure 3.11c

4. OPERATION

4.1 Main display functions



Figure 4.1 Main Display

A heart “♥” mark is lit on the right-upper corner of the screen when HART communication is active. An “X” mark is lit when HART communication is abnormal.

Nothing appears when HART communication is not used.

Note that the “X” mark may appear due to output signal noise or the like even when HART communication is not used. There is no problem when HART communication is not used. Continue operation while ignoring the mark.

4.2 Trending graphics

Pressing the button changes the display into a graphical mode in which the average measured value is shown on a time scale. The “Live” value is also digitally displayed in a text box. The time scale (X-axis) and the primary value scale (Y-axis) are set in the “DISPLAY SETUP” menu. The full screen displays a trend of 51 points that represent the average of the selected time interval. The converter samples the measurement every second. The trending graphic also shows the maximum and minimum measured value in that interval.

For example if the time scale is set to 4 hours, then the trend is shown for 4 hours prior to the actual measurement. Each point on the trend line represents the average over $4 \times 60 \times 60 / 51 = 282$ measurements (seconds).

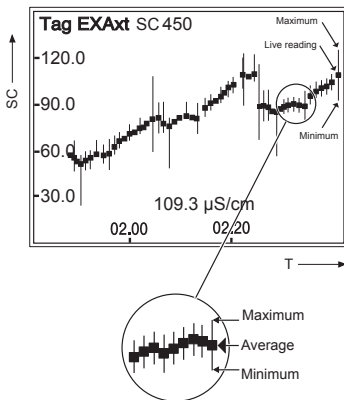
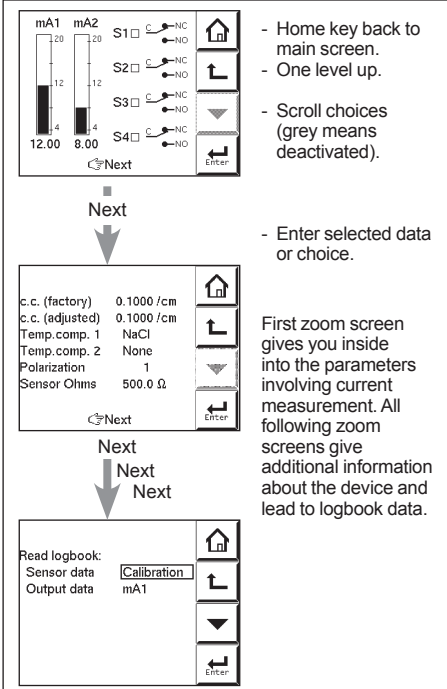

Figure 4.2 Trend screen

4.3 Zoom in on details

This button gives access to the diagnostic information of the converter. The following messages will appear under normal (default) conditions:



The diagram illustrates the zoom-in detail screen through three levels of information, each shown in a separate screen layout with navigation icons on the right:

- Level 1 (Top):** Shows two bar graphs for mA1 and mA2. mA1 has a value of 12.00 and mA2 has a value of 8.00. Below the graphs are four contact status indicators (S1, S2, S3, S4) with options for C, NC, and NO. Navigation icons include Home, Up, Down, and Enter.
- Level 2 (Middle):** Shows a list of parameters: c.c. (factory) 0.1000 /cm, c.c. (adjusted) 0.1000 /cm, Temp.comp. 1 NaCl, Temp.comp. 2 None, Polarization 1, and Sensor Ohms 500.0 Ω. Navigation icons include Home, Up, Down, and Enter.
- Level 3 (Bottom):** Shows logbook data: Read logbook: Sensor data Calibration, Output data mA1. Navigation icons include Home, Up, Down, and Enter.

Arrows labeled "Next" indicate the flow from the top screen to the middle screen, and from the middle screen to the bottom screen.

- Home key back to main screen.
- One level up.
- Scroll choices (grey means deactivated).

- Enter selected data or choice.

First zoom screen gives you inside into the parameters involving current measurement. All following zoom screens give additional information about the device and lead to logbook data.

Figure 4.3 Detail screen

4.3.1 Actual mA1

The current output in mA of the first current output, which is defined as mA1. The range and function of this mA output can be set in:

Routing:Commissioning >> Output setup>> mA1

4.3.2 Actual mA2

The current output in mA of the second current output, which is defined as mA2. The range and function of this mA output can be set in:

Routing:Commissioning >> output setup >> mA2

4.3.3 S1/S2/S3/S4

The current state of contacts 1 to 4. The functions and settings of the contacts can be set in:

Routing: Commissioning >> Output setup >> S1/S2/S3/S4

4.3.4 C.C. (factory)

The nominal cell constant as determined by the factory calibration during production. This value is set during commissioning, and is found on the nameplate of the sensor or the calibration certificate.

Routing: Commissioning >> Measurement setup >> Configure sensor

4.3.5 C.C. (adjusted)

The calibrated cell constant. When the cell constant of the system is adjusted on-line by grab sample or by calibrated solution technique, the new cell constant is recorded here. This value should not deviate greatly from the original factory calibration. In the event that there is a significant discrepancy seen between this reading and the C.C. (factory) value, the sensor should be checked for damage and cleanliness.

Routing is via the "Calibration" menu.

4.3.6 Temp. comp 1

The chosen temperature compensation method for the primary measurement.

Routing: Commissioning >> Measurement setup >> Temp.compensation

4.3.7 Temp. comp 2

The chosen temperature compensation method for the secondary measurement.

Note: This does not imply two separate measurements. There is the possibility to set two separate compensation methods so that two different stages of the same process can be monitored accurately. An example is process/cleaning fluid interface.

Routing: Commissioning >> Measurement setup >> Temp.compensation

4.3.8 Polarization

The polarization is measured by the input circuitry. Monitoring this figure gives a guide to progressive fouling of the sensor.

4.3.9 Sensor ohms

The input measurement as an uncompensated resistance value.

4.3.10 Last calibrated at

The date of the last calibration

4.3.11 Calibration due at

In the time frame scheduled for the next calibration. This field is determined by the calibration interval.

Routing: Commissioning >> Measurement setup >> Calibration settings

4.3.12 Projected calibration at

A diagnostic output, showing the time frame when the unit should next be maintained according to the sophisticated self-diagnostic tools built into the EXAxt software (for example >12 months, 3-6 months or 0-1 month).

The analyzer checks the rate of polarization every 24 hours. If a clear increase of polarization is observed, the user is notified when a next calibration should take place. Prior to calibration the sensor should be well cleaned and rinsed.

4.3.13 HART ID

A part of the HART device ID (descriptor)

4.3.14 Software revision

The revision level of the software in the instrument

TROUBLE SHOOTING

If you contact the local sales/ service organization the serial number and software revision is necessary information. Without that information it is impossible to help you. It is also very useful to report all the information that you find on the zoom-in display.

4.3.15 HART Device revision

Sometimes the firmware of a device is updated in a way that the communication file (HART DD) need revision too. In this case the revision level is increased by one. The revision level of the HART DD must match the revision level of the Firmware. The revision level is expressed by the first two characters of the filename.

The following files should be used when the HART Device revision level is 2.
(0201.aot, 0201.fms, 0201.imp, 0201.sym)

4.3.16 Logbook

The SC450G contains several logbooks to store history information on events, changed settings and calibrations. The logbooks have been categorized to simplify the retrieval of this information.

Calibration will give information of previous calibrations. This logbook is useful as one now can

- 1) Monitor the sensor performance over time.
- 2) Monitor the sensor(s) lifetime.

Sensor will give all history information on parameter settings concerning the sensor(s).

The events logged in this logbook are user definable. This is done in:

Commissioning >> Configure Logbook >> Sensor Logbook.

Predictive maintenance. If the sensor diagnostics of the SC450G are enabled, the diagnostics are saved into this logbook.

For the SC450G, the reference impedance (measured between the Liquid earth and the reference electrode) is stored every hour.

This information can be used for (predictive) maintenance schedules as the impedance is a measure of fouling and the sensor should be kept clean for best results.

Settings will give all history information on parameter settings concerning the analog outputs (mA1/mA2) and contact (S1...S4). This logbook is useful to trace back differences in performance due to changed settings. The events logged in this logbook are user definable. This is done in:

Commissioning >> Configure Logbook >> Settings Logbook – mA and/or Settings Logbook – contact



mA1/mA2 shows all (dynamic) events concerning the analog outputs

S1/S2/S3/S4 shows all (dynamic) events concerning the contacts.

Each HMI screen can contain up to 5 events.

As the logbook can contain 50, one can access previous events by selecting events page 1 to 10.



4.4 Information function

In this field an information sign , a warning sign  or a fail sign  can appear. Pushing this button, the user gets detailed information about the status of the sensor or the instrument if applicable.

See troubleshooting (chapter 8) for further details.

4.5 Setup-calibration & commissioning

By pressing the setup  key, you get access to the operating system of the converter based on menus and submenus.

Browse through the list using the  key till you find the required menu and press the  key to enter this menu.

It is also possible to press on the  or  symbol found beside the menu item.

4.6 Secondary-primary value display switch

Pressing on this text block automatically switches the secondary value to the main display (Large font size).

25.0

4.7 Navigation of the menu structure

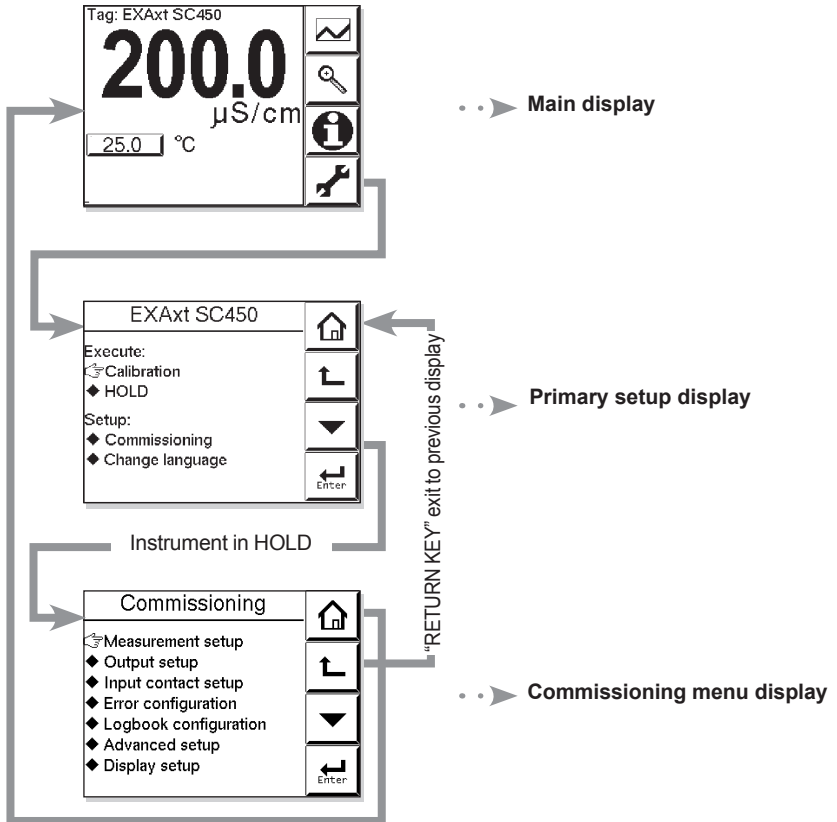

5. MENU STRUCTURE COMMISSIONING

On Measurement setup , define parameters. The access to the Measurement setup can be secured by password. If you use password, store the password information at a safe place.

When you start up the operation of the instrument, parameters are default values given at the factory. Define the parameters to suit the user's preference or purposes such as type of combination or sensors to use.

It is recommended to store each value as a user defined default as long as the operation runs smoothly after you change parameters .

You can also store the user defined default all at once in the following steps.

Measurement setup >> Advanced setup >> Defaults >> Save current as user defined
Read the item of Advanced setup in Chapter 5 for further description.



CAUTION

DO NOT turn off power immediately after you change the value. It may take approximately one minute to save the value after you change.

■ Measurement setup

● Main parameter

Choose the required parameter, either conductivity or resistivity. If the main parameter is changed the instrument will reset main display settings, units and recalculate several values. The menu structure will change accordingly.

5.1 Configure sensor

● Sensor type

Choose the sensor type used. Normally conductivity and/or resistivity measurements are done with 2-electrode type sensors. At high conductivity ranges, polarization of the electrodes may cause an error in conductivity measurement. For this reason 4-electrode type sensors may be necessary.

● Measuring unit /cm /m

Either /cm or /m can be chosen here. The process values will be expressed in S/cm or S/m respectively, (Ω .cm or Ω .m in resistivity mode).

Note: When measuring unit is changed, parameter of "mA output setup" and "contact output setup" will be cleared. Set these parameter again referring to subsection 5.6 to 5.7.

If you replace the sensor, delete the predictive maintenance log first on the logbook configuration screen in section 5.12. If you do not, proper prediction will not be possible using the sensor diagnostics.

You can check whether the log has been properly cleared by changing the sensor data to predictive maintenance under Read logbook on the Detail screen of figure 4.3 and then pressing Enter.

- **Cell constant (factory)**

Cell constant given by factory calibration. Usually given on a label on the sensor or the calibration certificate. Only change this value in case a new sensor is used. By changing this value the actual cell constant is also changed.

- **Measure**

Process values to be measured can be selected to suit the user's preference.: Conductivity only, Concentration only or one of both Conductivity and Concentration.

Note: this choice is not available in Resistivity mode.

5.2 Temperature setting

- **Temperature Element**

Selection of the temperature sensor used for compensation. The default selection is the Pt1000 Ohm sensor, which gives excellent precision with the two wire connections used.

The other options give the flexibility to use a very wide range of other sensors.

- **Temperature Unit**

Celsius or Fahrenheit temperature scales can be selected to suit the user's preference.

When the unit is changed all temperature related parameters and settings will be recalculated.

5.3 Temperature compensation

- **Compensation**

Two types of methods can be used here.

Automatic when a temperature element is used. Select one of the Temp. elements used.

The other is a manual set temperature. The manual temperature that represents the process temperature must be set here.

- **Reference Temperature**

Choose a temperature to which the measured conductivity value must be compensated. Normally 25°C (77°F) is used, therefore this temperature is chosen as default value.

- **Method**

TC

In addition to the temperature coefficient calibration routine it is possible to adjust the compensation factor directly. If the compensation factor of the sample liquid is known from laboratory experiments or has been previously determined, it can be introduced here.

Adjust the value between 0.00 to 3.50 % per °C. In combination with reference temperature a linear compensation function is obtained, suitable for all kinds of chemical solutions.

NaCl

Temperature compensation according NaCl curve. See appendix 1 for values.

Matrix

The SC450G is equipped with a matrix type algorithm for accurate temperature compensation in various applications. Select the range as close as possible to the actual temperature/concentration range. The SC450G will compensate by interpolation. If user defined 1 or user defined 2 is selected, the temperature compensation range for the adjustable matrix must be defined.

See Appendix 2 for matrix interpolation.

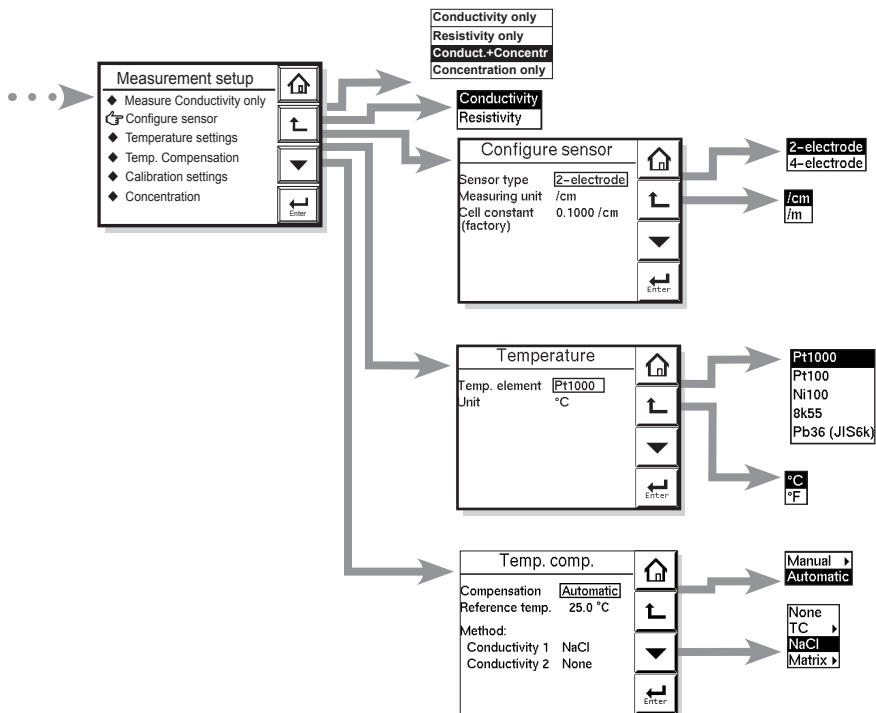

NOTE

“Main parameter” and/or “Measure” determines the rest of the HMI menu structure

Menu	Parameter	Default values	Range	
			min.	max.
Configure Sensor	Cell constant	0.1 cm ⁻¹	0.005 cm ⁻¹	50 cm ⁻¹
Temp. Comp.	Reference Temp.	25°C, 77°F	0°C, 32.0°F	100°C, 211°F
Manual Comp.	Manual Temp.	25°C, 77°F	-20°C, -3.0°F	250°C, 482°F
Temp. Coef	T.C.methods 1	2.10%/°C, 1.17%/°F	-10%/°C, 0%/°F	3.5%/°C, 2%/°F
	T.C.methods 2	2.10%/°C, 1.17%/°F	0%/°C, 0%/°F	3.5%/°C, 2%/°F

NOTE

Extra information on temperature compensation is given in appendix 1.

5.4 Calibration settings

- **Air adjust limit**

To avoid cable influences on the measurement, a “zero” calibration with a dry sensor may be done. If a connection box (BA10) and extension cable (WF10) are being used, “zero” calibration should be done including this connection equipment.

When using a 4-electrode sensor additional connections are required. Temporarily Interconnect terminals 13 & 14 with each other and 15 & 16 with each other before making the adjustment. This is necessary to eliminate the capacitive influence of the cables. The links should be removed after this step is completed.

As the calibration is performed in air the resistivity is infinite (open connection). Higher conductivity values than the air adjust limit indicate the cell is not in air or is still wet. To prevent wrong air calibrations a limit must be given here.

- **c.c. high limit**

High limit of the cell constant expressed in % of nominal value. During calibration this value is used to check if the calibrated cell constant remains within reasonable limits.

- **c.c. low limit**

Low limit of the cell constant expressed in % of nominal value. During calibration this value is used to check if the calibrated cell constant remains within reasonable limits.

- **Stabilization time**

During calibration the stability of the measurement is constantly monitored. When the value is within a bandwidth of 1% over a period of the stabilization time, the calibration is considered stable and the calibration may be completed.

- **Calibration Interval**

A user defined interval in which a new calibration should take place. If the interval is exceeded the instrument will give a warning or a fail (user definable in error configuration 2/3)

5.5 Concentration

Concentration has a direct relation with the conductivity value at reference temperature. This relation is built in every matrix which are used for temperature compensation. These can be found in:

Commissioning >> Measurement setup >> Temp. compensation >> Method

By selecting one of the matrices for temperature compensation directly gives the concentration value on the main display. If another temperature compensation method is chosen (NaCl or T.C.), the relation between the conductivity at reference temperature and the concentration is obtained from the “Concentration table”.

- **Additional table**

This 21x2 user defined concentration table is used to come to more accurate concentration values compared to the temperature compensation matrix. Enabling this additional table overrules the concentration values obtained from the matrix (if used).

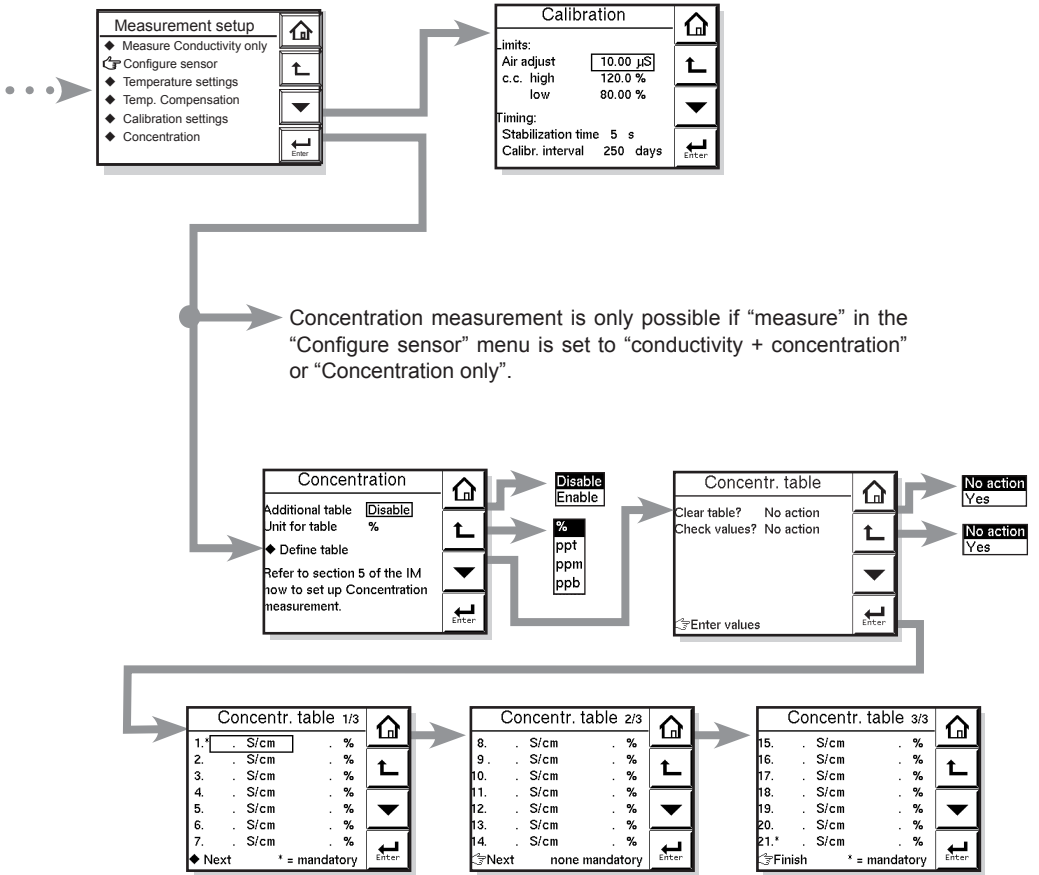

Menu	Parameter	Default values	Range	
			min.	max.
Calibration	Air adjust	10.00 μ S	0 μ S	20 μ S
	c.c. high	120%	100%	120%
	c.c. low	80%	80%	100%
	Stabilization time	5 s	2 s	30 s
	Calib. interval	250 days	1 day	250 days
Concentr. Table	Table	See appendix		

- **Unit for table**

The way the concentration values are presented to the user. Changing the unit will not result in a re-calculation of the table.

5.6 mA output setup

The general procedure is to first define the function (control, output, simulate, off) of the output and second the process parameter associated to the output.

Available process parameters depend on selected "sensor type" and "measurement setup".

Off :	When an output is set off the output is not used and will give an output of 4 mA
Control :	A selection of P- PI- or PID control
Manual :	Static output required to maintain reset equilibrium state with setpoint
Direction :	Direct. If the process variable is too high relative to the SP, the output of the controller is increased (direct action). Reverse. If the process variable is too high relative to the SP, the output of the controller is decreased (reverse action).
Output :	Linear or non linear table output. The table function allows the configuration of an output curve by 21 steps (5% intervals). In the main menu concentration can be selected to set the concentration range.
Simulate :	Percentage of output span. Normal span of outputs are limited from 3.8 to 20.5 mA
Fail safe :	Contact S4 is programmed as a fail-safe contact.

Burn Low or High will give an output of 3.6 resp. 21 mA in case of Fail situation.

NOTE

When leaving Commissioning, Hold remains active until switched off manually. This is to avoid inappropriate actions while setting up the measurement.

- **Proportional control**

Proportional Control action produces an output signal that is proportional to the difference between the Setpoint and the PV (deviation or error). Proportional control amplifies the error to motivate the process value towards the desired setpoint. The output signal is represented as a percentage of output (0-100%).

Proportional control will reduce but not eliminate the steady state error. Therefore, proportional Control action includes a Manual Reset. The manual reset (percentage of output) is used to eliminate the steady state error.

NOTE

Any changes (disturbances) in the process will re-introduce a steady state error.

Proportional control can also produce excessive overshoot and oscillation. Too much gain may result in an unstable- or oscillating process. Too little gain results in a sustained steady state error. **Gain = 1/Range. [PV units]**

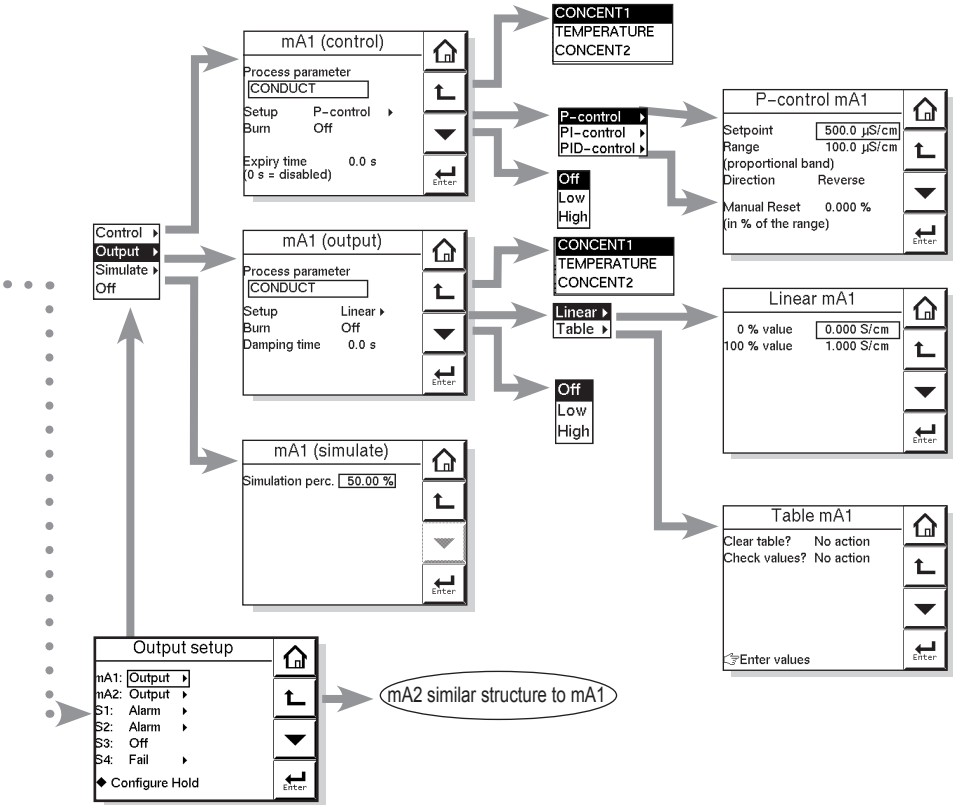

Menu	Parameter	Default values	Range	
			min.	max.
mA1 (control)	Expire time	0.0 sec.	0.0 sec.	1800 sec.
mA1 (output)	Damping time	0.0 sec.	0.0 sec.	3600 sec.
mA1 (simulate)	Simulation perc.	50 %	0 %	100 %
PID-control mA1	Setpoint	250.0 μ S/cm	(0.0 nS/cm)*	(999.9 S/cm)*
	Range	50.00 μ S/cm	(0.0 nS/cm)*	(999.9 S/cm)*
PID-control mA2	Setpoint	25°C/°F	(-99.9°C/°F)*	(999.9°C/°F)*
	Range	10.0°C/°F	(-99.9°C/°F)*	(999.9°C/°F)*
PID-control mA1	Manual Reset	0.000 %	0.000 %	100.0 %
PID-control	I-time	3600 sec.	1 sec.	3600 sec.
PID-control	D-time	0.0 sec.	0.0 sec.	60.0 sec.
Linear mA1	0% Value	0.000 S/cm	(0.0 nS/cm)*	(999.9 S/cm)*
	100% value	500.0 μ S/cm	(0.0 nS/cm)*	(999.9 S/cm)*
Linear mA2	0% Value	0.0°C/°F	(-99.9°C/°F)*	(999.9°C/°F)*
	100% value	100.0°C/°F	(-99.9°C/°F)*	(999.9°C/°F)*

*: User-settable value

- **Integral control**

Integral control is used to eliminate the steady state error and any future process changes. It will accumulate setpoint and process (load) changes by continuing to adjust the output until the error is eliminated. Small values of integral term (I-time in seconds) provide quick compensation, but increase overshoot. Usually, the integral term is set to a maximum value that provides a compromise between the three system characteristics of: overshoot, settling time, and the time necessary to cancel the effects of static loading (process changes). The integral term is provided with an anti windup function. When the output of PI portion of the controller is outside the control range (less than -5% or greater than 105%), the I-part is frozen.

- **Derivative control**

The control acts on the slope (rate of change) of the process value, thereby minimizing overshoot. It provides "rate" feedback, resulting in more damping. High derivative gains can increase the rising time and settling time. It is difficult to realize in practice because differentiation leads to "noisy" signals.

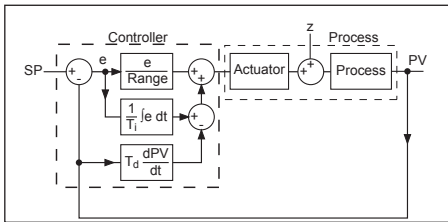

Figure 5.1 Control Diagram

- **Expire time**

If the output is over 100% for longer than the expire time, the output will return to 0%.

- **Damping time**

The response to a step input change reaches approximately 90 percent of its final value within the damping time.

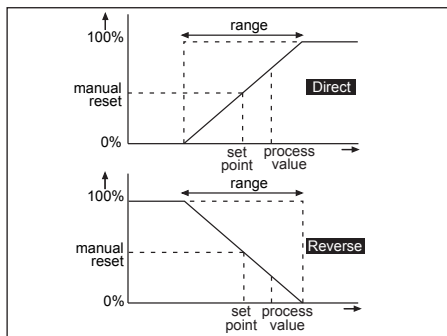
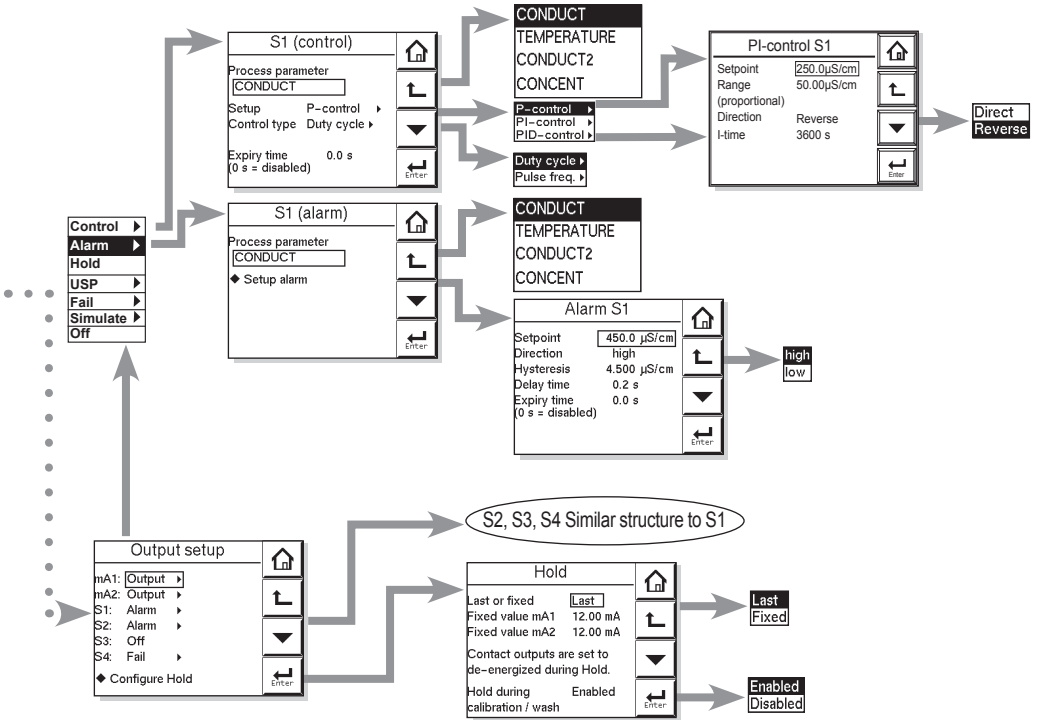

Figure 5.2 Direct/Reverse action



Menu	Parameter	Default values	Range	
			min.	max.
PID-control S1	Setpoint	250.0 $\mu\text{S/cm}$	(0.0 nS/cm)*	(999.9 S/cm)*
	Range	50.0 $\mu\text{S/cm}$	(0.0 nS/cm)*	(999.9 S/cm)*
P(ID)-control S1	Manual Reset	0.000%	0.000%	100.0%
PI(D)-control S1	I-time	3600 sec.	1 sec.	3600 sec.
P(I)D-control S1	D-time	0.0 sec.	0.0 sec.	60.0 sec.
Duty cycle	DC period time	10.0 sec.	1.0 sec.	1800 sec.
Pulse freq.	Max. pulse freq.	70 p/min.	1 p/min.	120 p/min.
Alarm S1	Setpoint	450 $\mu\text{S/cm}$ (high)	(0.0 nS/cm)*	(999.9 S/cm)*
Alarm S2	Setpoint	50.00 $\mu\text{S/cm}$ (low)	(0.0 nS/cm)*	(999.9 S/cm)*
Alarm S1	Hysteresis	4.500 $\mu\text{S/cm}$	(0.0 nS/cm)*	(999.9 S/cm)*
Alarm S2	Hysteresis	500.0 nS/cm	(0.0 nS/cm)*	(999.9 S/cm)*
Alarm	Delay time	0.2 sec.	0.0 sec.	1800 sec.
	Expire time	0.0 sec.	0.0 sec.	1800 sec.
Hold	Fixed value mA1	12.00 mA	3.600 mA	21.00 mA
	Fixed value mA2	12.00 mA	3.600 mA	21.00 mA



*: User-settable value

5.7 Contact output setup

● S1/S2/S3/S4

Each Switch (contact) can have the following functions.

1. Control: A selection of P- PI- or PID control
2. Alarm: Low or high value Limits monitoring
3. Hold: A hold contact is energised when the instrument is in HOLD
4. Fail: S4 is set as fail-safe contact. 6.
5. Simulate: To test the operation of the contact, simulate can be used. The contact can be switched on or off or a percentage of duty cycle can be entered (DC period time)
6. Off: Switch is not used.
7. USP: USP/EU limits for WFI

	power down	power on normal opened	power on contact activated
S1, S2, S3 S4			

Above table shows contact output status between common to NO.

● Configure hold

Hold is the procedure to set the outputs to a known state when going into commissioning. During commissioning HOLD is always enabled, outputs will have a fixed or last value. During calibration the same HOLD function applies. For calibration, it is up to the user if HOLD is enabled or not.

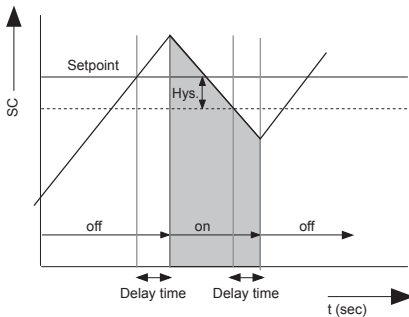
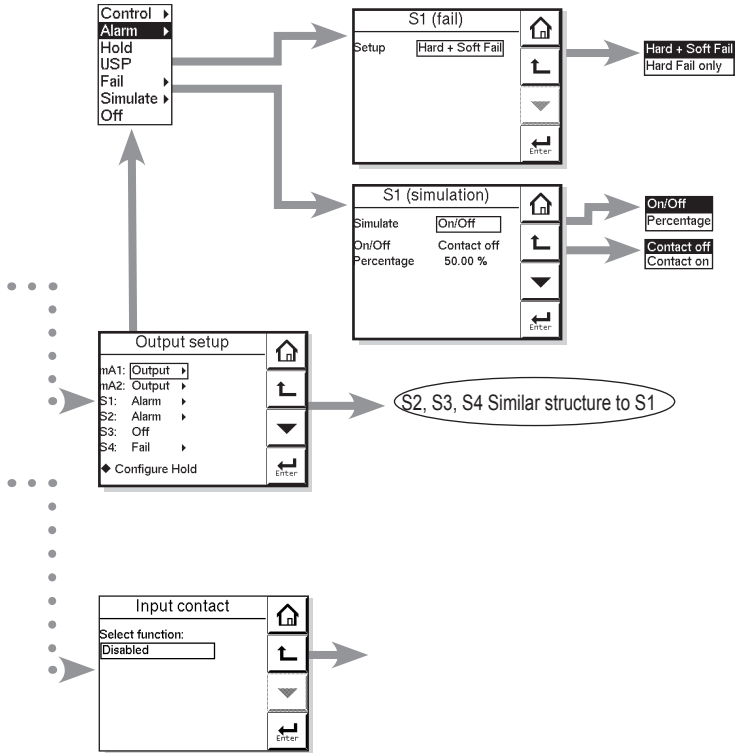

Figure 5.3 Alarm contact (on/off control)



Menu	Parameter	Default values	Range	
			min.	max.
Simulation	Percentage	50.0%	0.000%	100.0%

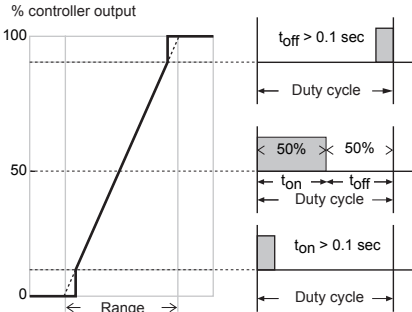

Figure 5.4 Duty cycle control

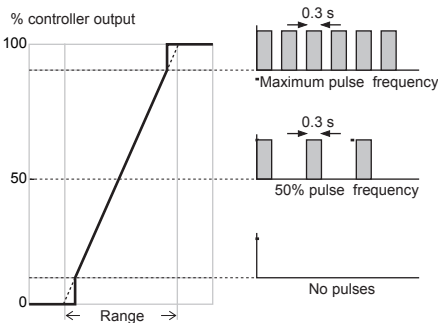

Figure 5.5 Pulse frequency control

● **Lifetime contacts**

One should note that the lifetime of the contacts is limited (10^6). When these contacts are used for control (pulse frequency or duty cycle with small interval times) the lifetime of these contact should be observed. On/Off control is preferred over Pulse/duty cycle.

5.8 Fail

A fail contact is energized when a fail situation occurs. Fail situations are configured in section 5.12. For SOFT Fails the contact and the display on LCD are pulsating. For HARD Fails the contact and the display on LCD are energized continuously.

Only contact S4 is programmed as a fail-safe contact. This means that contact S4 will be de-energized when a fail situation occurs.

Hard Fail Only

The contact reacts to Hard Fails Only

Hard + Soft Fail

The contact reacts to Hard and Soft Fails

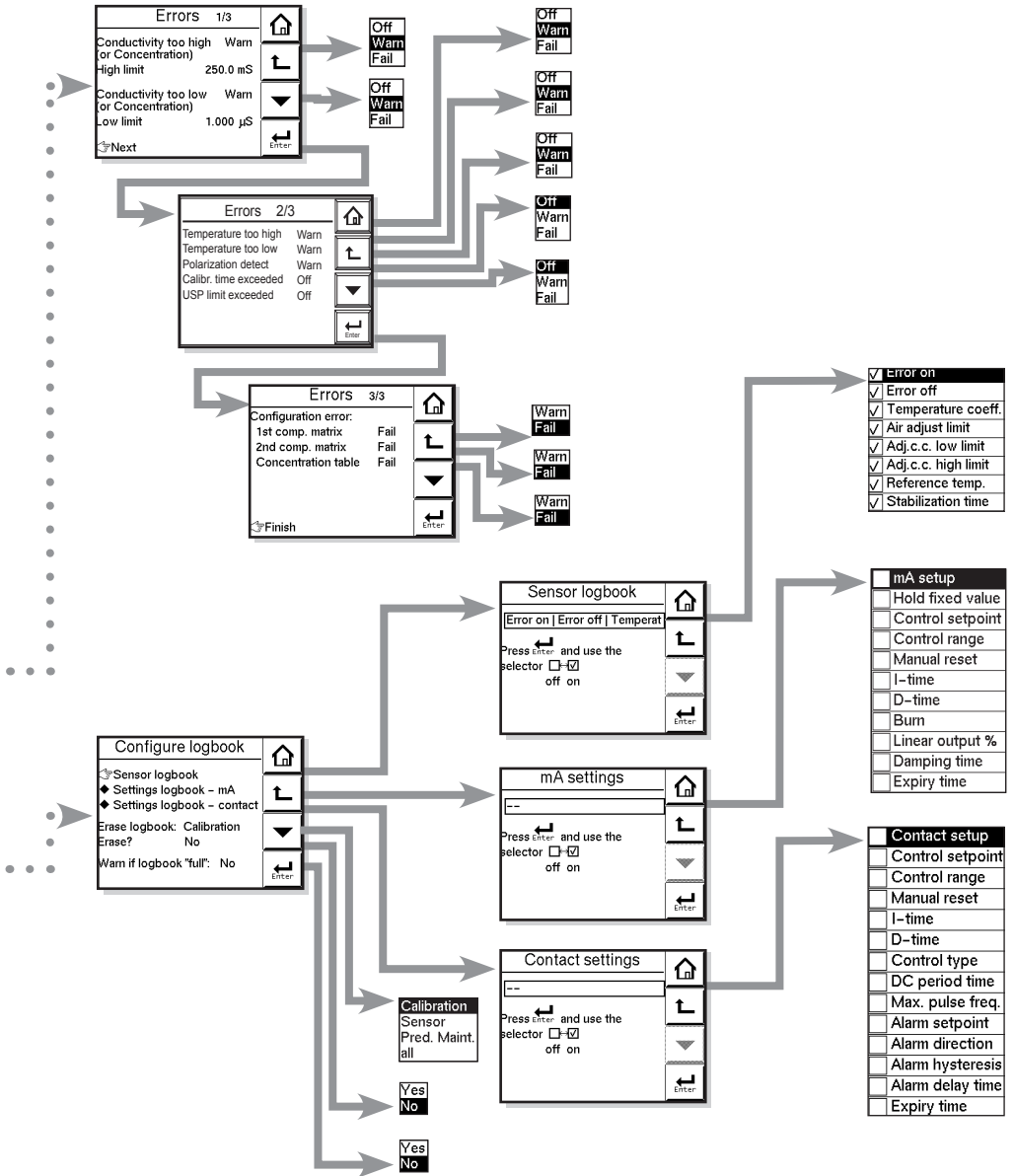

Menu	Parameter	Default values	Range	
			min.	max.
Errors 1/3	Cond. High Limit	250 mS	> 0 ms	2,000 S
	Cond. Low Limit	1,000 µS	> 0.00 µS	2,000 S
	Res. High Limit	4 Ω	> 0	10 MΩ
	Res. Low Limit	1 MΩ	> 0	10 MΩ

5.9 Simulate

The contact can be switched on/off or a percentage of output can be simulated. On/Off enables the user to manually switch a contact on or off. The percentage is an analogue value and represents the on time per period.

The Duty cycle Period time (see figure 5.4) is used as a period for percentage simulation.

Note that the (simulated) settings of the contacts become visible in measuring mode and after HOLD has ended c.q. has been overruled. A warning is activated in case of a simulated output contact.

5.10 Water for Injection Monitoring (USP 645 and EU 0169)

● Setting up SC450G for WFI monitoring

1. A function "USP limit exceeded" is defined as an error code on sec. 5-12, Errors 2/3. This can be set to off/warn/fail according to your requirement. This function can be modified by the function "USP safety margin" in %. This is a percentage of the WFI conductivity value at that temperature that serves as safety margin. This is independent of what is being measured. The display shows this error when the water quality exceeds the WFI conductivity limits as set in stage 1.
2. We have introduced uncompensated conductivity in the DISPLAY menu. In the LCD display the user can read the temperature and the raw conductivity to compare his water quality with the WFI table.
3. We have added a USP function to the contact allocation. The contact output S1 can be selected as USP alarm if the function "USP limit exceeded" has been selected.

The contact closes when the USP limit is reached.

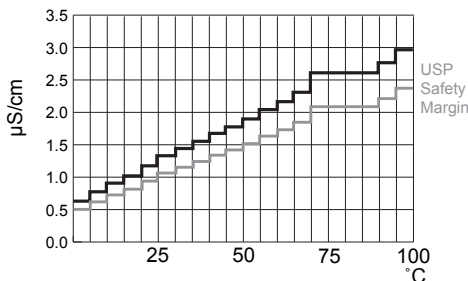
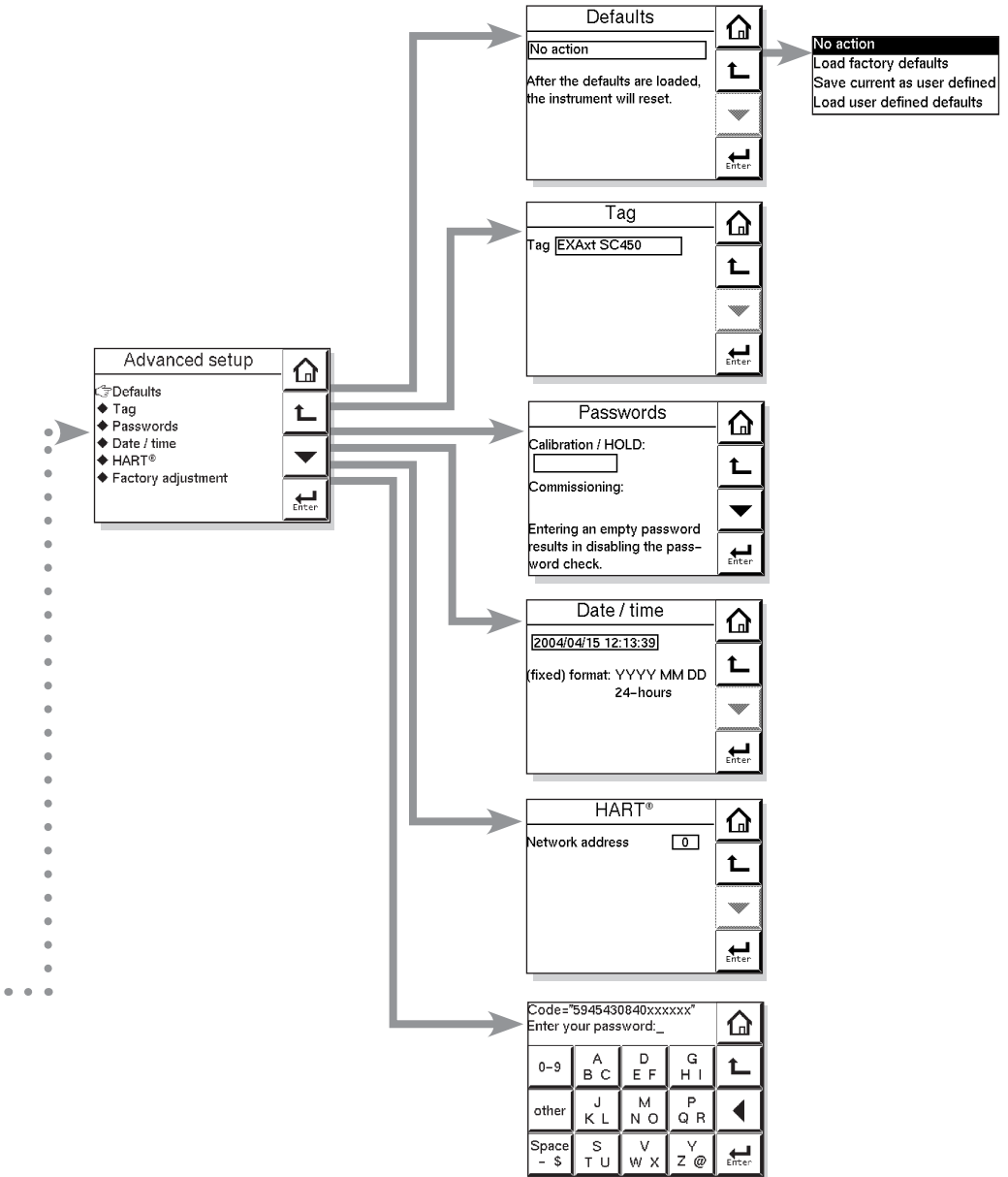

Figure 5.6 USP Safety Margin

Limit of uncompensated conductivity as function of temperature as defined for WFI. USP safety margin set as 20 % will close the contact at 80 % of the conductivity value at all temperatures.

For example, if the temperature is 64 °C. and the safety margin is adjusted for 20%, then the contact closes at $0.8 \times 2.2 \mu\text{S/cm} = 1.76 \mu\text{S/cm}$. ($2.2 \mu\text{S/cm}$ is the WFI limit at 64°C). In resistivity mode the contact will close at an uncompensated resistivity of $1/1.76 \mu\text{S/cm} = 0.568 \text{ Mohm}$.

Recommended Commissioning settings when monitoring WFI in a > 80 °C WFI installation.



Menu	Parameter	Default values	Range	
			Low	High
HART	Network address	0	0	15

- **Commissioning**

Measurement Set up	
Measure	Conductivity only
Temp Compensation	automatic
Conductivity 1	None
Error Configuration (Errors 2/3)	
USP limit exceeded	Warn
Output Setup	
S1	USP
USP safety margin	10 %
S2	Alarm
Parameter	Temperature
Setpoint	80 C
Direction	Low
Delay Time	0.2 s
Expiry Time	0 (disabled)

5.11 Input contacts

The terminal of the SC450G provides for an input contact (see Figure 3.7). This input contact can be used to switch the range of the outputs. The range can be increased by 1 decade. This is available for only mA1 output.

5.12 Error configuration

- **Errors 1/3 ~ 3/3**

Errors are intended to notify the user of any unwanted situations. The user can determine which situations should be classified as:

FAIL, immediate action is required. The process variable is not reliable.

WARN, the process variable processes by the converter is still reliable at this moment, but maintenance is required in the near future.

- **Flashing “Fail” flag in main display**  

“FAIL” gives a flashing “FAIL” flag in the main display. The contact configured as FAIL (**Commissioning >> output setup**) will be energized continuously. All the other contacts are inhibited. Exception is the contact configured for 'Wash'. Wash cycles are not interrupted as this might cause scaling/fouling to the electrodes. A Fail signal is also transmitted on the mA-outputs when enabled (burn high/low). (**Commissioning >> output setup**)

- **Flashing “Warn” flag in main display**  

“WARN” gives a flashing “WARN” flag in the display. The contact configured as FAIL is pulsed. All the other contacts are still functional, and the converter continues to work normally. A good example is a time-out warning that the regular maintenance is due. The user is notified, but it should not be used to shut down the whole measurement.

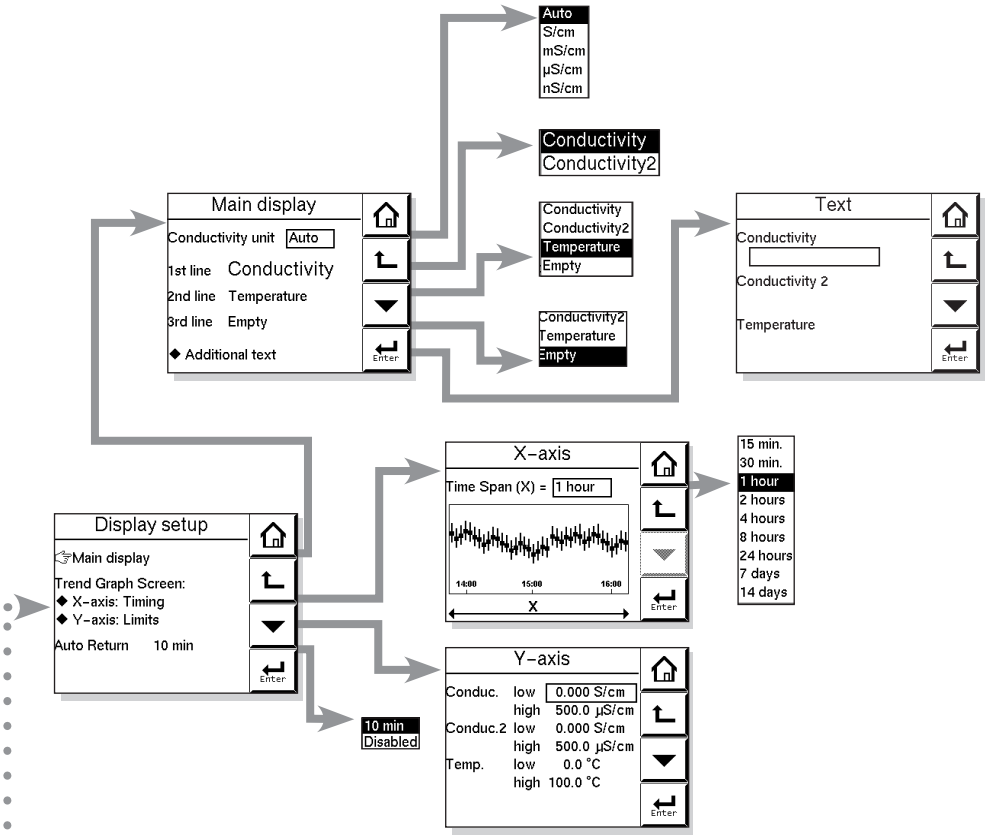

Menu	Parameter	Default values	Range	
			Low	High
Y-axis	Conduct low	0.000 S/cm	(0.0 nS/cm)*	(999.9 S/cm)*
	Conduct high	500.0 µS/cm	(0.0 nS/cm)*	(999.9 S/cm)*
	Conduct 2 low	0.000 S/cm	(0.0 nS/cm)*	(999.9 S/cm)*
	Conduct 2 high	500.0 µS/cm	(0.0 nS/cm)*	(999.9 S/cm)*
	Temp. low	0.0°C/°F	(-99.9°C/°F)*	(999.9°C/°F)*
	Temp. high	100.0°C/°F	(-99.9°C/°F)*	(999.9°C/°F)*

*: User-settable value

5.13 Logbook configuration

- **General**

Logbook is available to keep an electronic record of events such as error messages, calibrations and programmed data changes. By reference to this log, users can for instance easily determine maintenance or replacement schedules.

In “Configure Logbook” the user can select each item he is interested in to be logged when the event occurs. This can be done for three separate logbooks. Each logbook can be erased individually or all at once. Enable the “Warn if Logbook full” when you would like to be warned when the logbook is almost full. The content of the logbook(s) can also be retrieved from the converter using the “EXAxt Configurator” software package which can be downloaded from the Yokogawa Europe website.

5.14 Advanced setup

- **Defaults**

The functionality of the SC450G allows to save and load defaults to come to a known instrument setting. The SC450G has both factory and user defined defaults.

After a “load default” the instrument will reset.

The following parameters are not included in the defaults

1. X-axis timing
2. Auto return (10 min / disabled)
3. Tag
4. Passwords
5. Date and time
6. Language
7. The contents of all logbooks
8. HART parameters (address, tag, descriptor, message)

- **Tag**

A tag provides a symbolic reference to the instrument and is defined to be unique throughout the control system at one plant site. A tag can contain up to 12 characters. If the instrument is purchased with the /SCT option, the TAG is pre-programmed with the specified tag number.

- **Passwords**

Calibration and Commissioning may be separately protected by a password. By default both passwords are empty. Entering an empty password results in disabling the password check. A password can contain up to 8 characters. When a password is entered for the calibration and commissioning a 4-digit operator ID can be entered. One can also leave the ID empty.

- **Date/time**

The Logbooks and trend graph use the clock/calendar as reference. The current date and time is set here. The current time is displayed in the third “zoom” menu.

NOTE

The fixed format is YYYY/MM/DD HH:MM:SS

- **HART**

The address of the SC450G in a HART network can be set. Valid addresses are 0...15.

- **Factory adjustment**

This menu is for service engineers only. This section is protected by a password.

Attempting to change data in the factory adjustment menu without the proper instructions and equipment, can result in corruption of the instrument setup, and will impair the performance of the unit.

5.15 Display setup

- **Main display**

The main display consists of three lines with Process Values. Each line is user definable with the restriction that each line should have a different Process Value. The default settings can be defined here. By pressing one of the two smaller process values, this will become the main process value in the main screen. Auto return will cause the main display to go to default setting.

See also 4.6 Secondary to Primary Value display Switch.

NOTE

Configuration possibilities in the main and secondary display lines are determined by the choices made in the menu measurement

Measurement setup >> Measurement

- **Additional text**

Each process value can be given an additional text containing up to 12 characters per text. This text is displayed on the main display next to the process value. This way the user can distinguish separate measurements.

- **X-axis timing**

The time range of the trend graph can be set from 15 minutes up to 14 days.

- **Y-axis limits**

The ranges for each measurement need to be set according the application.

- **Auto return**

When Auto return is enabled, the converter reverts to the measuring mode (main display) from anywhere in the configuration menus, when no button is pressed during the set time interval of 10 minutes. The HOLD flag will be cleared and all outputs will function normally.

Blank Page

6. CALIBRATION

The nominal cell constant of a conductivity sensor is determined at the construction stage, because it is a factor set by the size of the electrodes, and their distance apart. A conductivity sensor does not change its cell constant during operation, as long as it remains undamaged, and clean. It is therefore vital that in any calibration check the first step should be to clean the sensor, or at least check its cleanliness. After cleaning ensure that the sensor is carefully rinsed in distilled water to remove all traces of the cleaning medium.

In the commissioning menu, the original sensor configuration will include the programming of the cell constant defined for the sensor at manufacture. Follow the routing below to the setup screen :

Commissioning >> Measurement setup >> Configure sensor

The Calibration menu of the SC450G is provided for fine tuning the sensor setup, and checking and verification after a time in service.

Where 1st and 2nd compensations are referred to in this part of the menu, these provide alternatives for the “wet” calibration, designed to give the user the greatest flexibility.

This does not mean that two cell constants can or should be calibrated, they are alternative routes to the same end!

6.1 Cell constant manual

The intention of this calibration routine is to fine tune a sensor for which only the nominal cell constant is known, or recalibrate a sensor that has been changed (or damaged) in the course of operation. Choose 1st or 2nd compensation to suit the calibration solution used. The solution should be prepared or purchased, meeting the highest standards of precision available. Allow the sensor to reach stable readings for both temperature and conductivity before adjusting to correspond to the calibration solution value. The setting of a cell constant for a new (replacement) sensor is also possible in this routine. This avoids the need for entry into the commissioning mode, which may have another authorization (password) level.

Regarding how to enter cell constant of the SC21□G, SC8SG, and SC4AJ, see “Appendix 5.”

6.2 Cell constant automatic

This routine is built around the test method described in OIML (Organisation Internationale de Metrologie Legale). International Recommendation No. 56. It allows the direct use of the solutions prescribed in the test method, automatically selecting the appropriate temperature compensation. The look up table is used to find the appropriate conductivity reading for the measured temperature. See appendix 2 for OIML solutions

6.3 Air (zero) calibration

With the clean dry cell in open air, the reading should be zero. The Air cal compensates for excess cable capacitance, and gives a better accuracy at low readings. This should be done for all installations during commissioning. After some time in service a dirty sensor may well show a high zero offset because of fouling. Clean the sensor and try again.

6.4 Sample calibration

With the sensor in situ, a sample can be taken for laboratory analysis. Sample calibration records the time and reading, and holds these in memory until the analysis has been completed. The laboratory data can then be entered regardless of the current process value, without the need for calculations.

6.5 Temperature coefficient calibration

Simply input the solution conductivity at reference temperature (T_R), after the sensor is allowed to stabilize at elevated temperature. The SC450G will calculate the temperature coefficient for you. The ideal temperature for this calibration, is the normal process value (T_P). For good calibrations, the minimum span ($T_P - T_R$) should be at least 2°C.

Note that the Temperature Compensation should be set to TC first.

6.6 Temperature calibration

In order to make the most accurate measurements, it is important to have a precise temperature measurement. This affects the display of temperature, and the output signal when used. More important, however, is the temperature compensation, and calibration accuracy.

The temperature of the sensor system should be measured independently with a high precision thermometer. The display should then be adjusted to agree with the reading (zero offset calibration only). For best accuracy this should be done as near to the normal operating temperature as possible.

6.7 Operation of hold function during calibration

SC450G has a HOLD function that will suspend the operation of the control/alarm relays and mA-outputs.

During calibration, the user may choose to enable HOLD so that the output signals are frozen to a "last" or "fixed" value. Some users will choose to leave the outputs "live" to record the calibration event. This has implications for pharmaceutical manufacture, for example, where an independent record of calibrations is mandatory.

Press HOLD button on main screen, to remove the HOLD.

The route for HOLD setup is

Commissioning >> Output setup>> Configure Hold

6.8 General comments on SC calibration

- SC sensors experience no drift except if they are damaged or dirty
- There are no good calibration solutions (like pH buffer solutions)
- Solution calibration of SC demands laboratory technical skills
- Solutions can be used to give a fair calibration check at higher conductivity
- Solutions can NOT be used to check calibration at low conductivity.
- Low conductivity solutions <10µS/cm absorb CO₂ from the air very fast
- Low conductivity measurement must be made only with air excluded
- Apparatus must be scrupulously clean to avoid contamination
- Sensor linearity is never a problem for lower values
- A dirty sensor is prone to polarization

- Polarization shows as a low side error at higher conductivity
- A dirty sensor will often read perfectly at low conductivity
- Wet calibration tests are best done towards the top of a sensor's range
- If the system responds correctly to the highest trip point, all is well

Blank Page

7. MAINTENANCE

SPARE PARTS

See Customer Maintenance Parts List.

7.1 Periodic maintenance

The converter requires very little periodic maintenance, except to make sure the front window is kept clean in order to permit a clear view of the display and allow proper operation of the touchscreen. If the window becomes soiled, clean it using a soft damp cloth or soft tissue. To deal with more stubborn stains, a neutral detergent may be used.

When you must open the front cover and/or glands, make sure that the seals are clean and correctly fitted when the unit is re-assembled in order to maintain the housing's weatherproof integrity against water and water vapor. The pH measurement uses high impedance sensors and may otherwise be prone to problems caused by exposure of the circuitry to condensation.

NOTE

Never use harsh chemicals or solvents. In the event that the window does become heavily stained or scratched, refer to the parts list for replacement part numbers.

- **Battery**

The SC450G converter contains a logbook feature that uses a clock to provide the timings. The instrument contains a lithium cell (battery) to support the clock function when the power is switched off. The cell has an expected working life of 10 years. Should this cell need to be replaced, contact your nearest Yokogawa service center.

- **Fuse**

There is a circuit board mounted fuse protecting the instrument. If you suspect that this needs to be replaced, contact your nearest Yokogawa service center.

7.2 Periodic maintenance of the sensor

NOTE

Maintenance advice listed here is intentionally general in nature. Sensor maintenance is highly application specific.

In general conductivity measurements do not need much periodic maintenance. If the SC450G indicates an error in the measurement or in the calibration, some action may be needed (ref. chapter 8 troubleshooting).

When a 2-electrode sensor has become fouled an insulating layer may be formed on the surface of the electrodes and consequently, an apparent increase in cell constant may occur, giving a measuring error.

This error is: $2 \times R_v/R_{cel} \times 100 \%$

where: R_v = the resistance of the fouling layer

R_{cel} = the cell resistance

NOTE

Resistance due to fouling or to polarization does not effect the accuracy and operation of a 4-electrode conductivity measuring system. If an apparent increase in cell constant occurs cleaning the cell will restore accurate measurement.

7.3 Cleaning methods

1. For normal applications hot water with domestic washing-up liquid added will be effective.
 2. For lime, hydroxides, etc., a 5 ...10% solution of hydrochloric acid is recommended.
 3. Organic contaminants (oils, fats, etc.) can be easily removed with acetone.
 4. For algae, bacteria or moulds, use a solution of domestic bleach (hypochlorite).
- * Never use hydrochloric acid and bleaching liquid simultaneously. The release of the very poisonous chlorine gas will result.

7.4 LCD adjustment

● Contrast adjustment

During the life of the analyzer the contrast of the display may fade. The contrast can be adjusted using the potentiometer on the backside of the LCD board. This adjustment must be done only by Yokogawa's service personnel. The position is shown on the picture below.

For units manufactured after July 2007, the potentiometer is placed behind the little hole in the LCD bracket as shown in Figure 3.4.

For units manufactured between April 2006 and April 2007, the potentiometer is located as shown below.

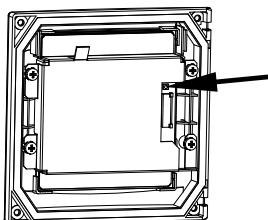

● Touchscreen adjustment



CAUTION

A few years after using, the touchscreen may deviate from the correct position due to aging deterioration of the touchscreen. When that happens, turn off power then on again. The touchscreen will be calibrated automatically to the correct touch position at power on. It is recommended to turn off power then on again when periodic maintenance.



CAUTION

Do not turn on power with the touchscreen pressed, otherwise inaccurate touch position will occur. If it occurs, leave the touchscreen unpressed, turn off power then on again. The touch position will be accurate.

8. TROUBLESHOOTING

If you contact the local sales/ service organization the serial number and software revision (section 4.3.14) is necessary information. Without that information it is impossible to help you. It is also very useful to report all the information that you find on the zoom-in display.

The SC450G is a microprocessor-based converter that performs continuous self-diagnostics to verify that it is working correctly. Error messages resulting from faults in the micro-processor systems itself are monitored. Incorrect programming by the user will also result in an error, explained in a message, so that the fault can be corrected according to the limits set in the operating structure. The SC450G also checks the sensor system to establish whether it is still functioning properly.

In the main display screen is a "Status Information" button that will show

- **For information** 

- **For warning** 

- a potential problem is diagnosed, and the system should be checked.

- **For FAIL** 

, when the diagnostics have confirmed a problem, and the system must be checked.

This button gives access to a status report page, where "**The most applicable error**" will be displayed. ("**No errors**" is displayed during proper operation)

- **Explanation** 

>> Description or error message and possible remedies

- **Advanced troubleshooting** 

>> Error code screen that is used in conjunction with the service manual. This data may also be needed in the event that you request assistance from a Yokogawa service department.

What follows is a brief outline of the SC450G troubleshooting procedures including possible causes and remedies.

8.1 Calibration check

The SC450G converter incorporates a diagnostic check of the adjusted cell constant value during calibration. If the adjusted value stays within 80-120 % of the factory value, it is accepted, otherwise, the unit generates an error message, and the calibration is rejected.

8.2 Polarization check

The SC450G performs on-line monitoring to detect polarization. This is an early indicator for sensor fouling. The detection of polarization in the measurement gives a warning of the onset of sensor coating, before significant measuring errors build up.

8.3 Predictive maintenance

SC450G has a unique prediction feature. Calibration, data is stored in software data logbooks. This data is then used to calculate a prediction for maintenance purposes.

8.4 Prediction of cleaning needed

The date when the next maintenance is needed is calculated from on-line polarization checks. The trend of polarization measurements on the sensor is used to calculate when to tell the user when to clean the sensor.

8.5 Poor calibration technique

When the calibration data is not consistent this fact is used as a diagnostic tool. The significance of this error message is to require the user to improve his calibration technique. Typical causes for this error are attempting to calibrate dirty sensors, calibration solution contamination and poor operator technique.

8.6 Error displays and actions

All errors are shown in the “Main Display” screen, however, the SC450G makes a distinction between diagnostic findings. The error messages may be set to OFF, WARN or FAIL. For process conditions where a particular diagnostic may not be appropriate, the setting OFF is used. FAIL gives a display indication only of that the system has a problem and inhibits the relay control action, and can be set to trigger the “Burn” function. “Burn-up or Burn-down” drives the mA output signal to 21 mA or 3.6 mA respectively.

APPENDIXES

Appendix 1 Temperature compensation

The conductivity of a solution is very dependent on temperature. Typically for every 1°C change in temperature the solution conductivity will change by approximately 2%. The effect of temperature varies from one solution to another and is determined by several factors like solution composition, concentration and temperature range. A coefficient (α) is introduced to express the amount of temperature influence in % change in conductivity/°C. In almost all applications this temperature influence must be compensated before the conductivity reading can be interpreted as an accurate measure of concentration or purity.

■ NaCl or standard temperature compensation

From the factory the SC450G is set with the default of a general temperature compensation function based on a Sodium Chloride solution. This is suitable for many applications and is compatible with the NaCl compensation functions of typical laboratory or portable instruments. SC temperature compensation.

Table 1 NaCl-compensation according to IEC 60746-3 with Tref = 25 °C

T	Kt	α	T	Kt	α	T	Kt	α
0	0.54	1.8	60	1.76	2.2	130	3.34	2.2
10	0.72	1.9	70	1.99	2.2	140	3.56	2.2
20	0.90	2.0	80	2.22	2.2	150	3.79	2.2
25	1.00	—	90	2.45	2.2	160	4.03	2.2
30	1.10	2.0	100	2.68	2.2	170	4.23	2.2
40	1.31	2.0	110	2.90	2.2	180	4.42	2.2
50	1.53	2.1	120	3.12	2.2	190	4.61	2.2
					2.2	200	4.78	2.2

■ Configure calculated temperature coefficient (TC).

Follow routing

Commissioning >> Measurement setup >> Temp.compensation >> T.C.

Enter the temperature coefficient calculated from the following formula:

A. Calculation of temperature coefficient factor (With known conductivity at reference temperature).

$$\alpha = \frac{K_t - K_{ref}}{T - T_{ref}} \times \frac{100}{K_{ref}}$$

α = Temperature compensation factor in %/°C

T = Measured temperature in °C

K_t = Conductivity at T

T_{ref} = Reference temperature

K_{ref} = Conductivity at T_{ref}

B. Calculation of temperature coefficient factor (with two known conductivity values at different temperatures)

Measure the conductivity of the liquid at two temperatures, one below the reference and above the reference temperature with the temperature coefficient set to 0,00%/°C and use the following equation to calculate a temperature coefficient (α).

$$K_{\text{ref}} = \frac{K_T}{1 + \alpha (T - T_{\text{ref}})}$$

$$K_{\text{ref}} = \frac{K_1}{1 + \alpha (T_1 - T_{\text{ref}})} = \frac{K_2}{1 + \alpha (T_2 - T_{\text{ref}})}$$

$$K_1 (1 + \alpha (T_2 - T_{\text{ref}})) = K_2 (1 + \alpha (T_1 - T_{\text{ref}}))$$

$$K_1 \cdot \alpha (T_2 - T_{\text{ref}}) - K_2 \cdot \alpha (T_1 - T_{\text{ref}}) = K_2 - K_1$$

$$\alpha = \frac{K_2 - K_1}{K_1 (T_2 - T_{\text{ref}}) - K_2 (T_1 - T_{\text{ref}})}$$

Where T_1, T_2 : liquid temperature (°C)

K_1 : conductivity at T_1 (°C)

K_2 : conductivity at T_2 (°C)

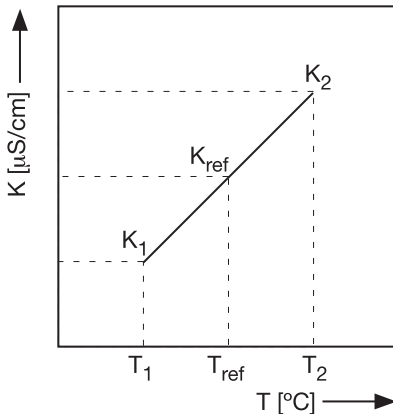

Figure 1 Conductivity

Calculation example

Calculate the temperature co-efficient of a liquid from the following data.

Conductivity 124.5 $\mu\text{S}/\text{cm}$ at a liquid temperature of 18.0 °C and a conductivity 147.6 $\mu\text{S}/\text{cm}$ at a liquid temperature of 31.0 °C.

Substituting the data in the above formula gives the following result.

$$\alpha = \frac{147.6 - 124.5}{124.5(31.0 - 25) - 147.6(18.0 - 25)} \times 100 = 1.298 \text{ \%}/\text{C}$$

Set the temperature coefficient in the SC450G converter.

- **Checking**

When the temperature coefficient already set is accurate, the conductivity to be displayed must be constant regardless of liquid temperature. The following check will make sure that the temperature coefficient already set is accurate.

If, when the liquid temperature is lowered, a larger conductivity value is indicated, the temperature coefficient already set is too small.

The opposite also applies. If a smaller conductivity value is indicated, the temperature coefficient already set is too large. In either case, change the temperature coefficient so that the conductivity no longer changes.

- **Matrix compensation**

The compensation matrix is a table of temperature and conductivity values at differing concentrations. These values are used to calculate the temperature compensation applicable for a particular solution. Choose the component that you will be measuring in your application, and where appropriate the concentration range. SC450G will do the rest.

By following the routing:

Commissioning>> Measurement setup>> Temp.compensation>> Matrix

you gain access to the Matrix selection area.

Matrices are available for the common mineral acids and bases. In addition Ammonia and Morpholine are included.

In short by using the matrix method, specialist compensation is available for the majority of applications in the power industry, water treatment, and chemical manufacturing. The following matrices are available initially, but as with all Yokogawa products, we are continually striving to improve both the quality and technological content. Further solutions will be added to this list.

Select matrix	Concentration	Temperature
Ammonia 0..50 ppb	0 to 50 ppb	0 to 90 °C
Morpholine 0..500 ppb	0 to 500 ppb	0 to 90 °C
Ammonia 15..30%	15 to 30 %	10 to 50 °C
Sulfuric acid 0..27%	0 to 27 %	-1.1 to 98.9 °C
Sulfuric acid 39..85%	39 to 85 %	-17.8 to 115.6 °C
Sulfuric acid 93..100%	93 to 100 %	10 to 90 °C
NaOH 0..15%	0 to 15 %	0 to 100 °C
NaOH 25..50%	25 to 50 %	0 to 80 °C
HCl 0..200 ppb	0 to 200 ppb	0 to 100 °C
HCl 0..18%	0 to 18.2 %	-10 to 65 °C
HCl 24..44%	23.7 to 43.8 %	-20 to 65 °C
HNO ₃ 0..25%	0 to 24.80 %	0 to 80 °C
HNO ₃ 35..88%	35.0 to 87.7 %	-16 to 60 °C

■ **Temperature compensation matrix.**

1. A minimum number of values is required to make interpolation possible. The highlighted values marked as are mandatory to enter.

	Concent	Tref	T1	Tx	T10
Sol1	C1	S1Tr	S1T1				S1T10
....							
Solx					SxTx		
....							
Sol10	C10	S10Tr	S10T1				S10T10

2. Tref (reference temperature) is defined in the Temperature Compensation menu. If Tref is between T1 and T10 then the value of Tref needs to be entered as Tx (T2....T9).

	Concent	Tref	T1	Tx T10	
Sol1	C1	S1Tr	S1T1				S1T10
....							
Solx							
....							
Sol10	C10	S10Tr	S10T1				S10T10

3. For every SxTx that is entered the following values become mandatory to enter: Cx, SxTr, SxT1, SxT10 and Tx.

	Concent	Tref	T1	Tx T10	
Sol1	C1	S1Tr	S1T1				S1T10
....							
Solx	Cx	SxTr	SxT1		SxTx		SxT10
....							
Sol10	C10	S10Tr	S10T1				S10T10

The matrix can be cleared before entering new values. Next new matrix values can be entered as described above. The SC450G can interpolate the matrix. During this process it will check if the matrix is completely ascending/descending. This is necessary as otherwise the lookup function can give two results for one temperature. If an error is found, the SC450G will specify the location of the error as shown in the user interface screen “user defined 1/2”.

The backspace key should be used for deleting an individual matrix value.

An empty value is shown as %.

User defined 1 🏠

Concentration unit

Clear matrix? No action ↶

Check values? No action ⏴

◆ Enter values Enter

No action
Yes

New value: % 🏠

-	7	8	9	↶
·	4	5	6	⏴
0	1	2	3	Enter

Appendix 2 TDS readings

The concept of Total Dissolved Solids (TDS) is widely used as an indication of the total solute concentration in water and is a widely accepted water quality standard. The determination is simply made by evaporation and weighing the residue. As the heat treatment converts the chemical properties of the solution, some solutes that contribute to the total conductivity will not be found in the residue. Also some combinations of solutes will become volatile at the drying temperature. The same applies for those solutes that do not contribute to the conductivity but do end up in the residue. When one (or a few) solute is dominant in the solution, these problems may be neglected and TDS will have a direct correlation with the conductivity. Next is a graph that shows the correlation between the specific conductance and concentrations (by weight) for six salts. The factor by which the conductivity should be multiplied to come to a TDS reading ranges from 0.4 to 0.7 up to a conductivity of 500 $\mu\text{S}/\text{cm}$. At a conductance of approximately 3000 $\mu\text{S}/\text{cm}$ the range would be from 0.5 and 1.0.

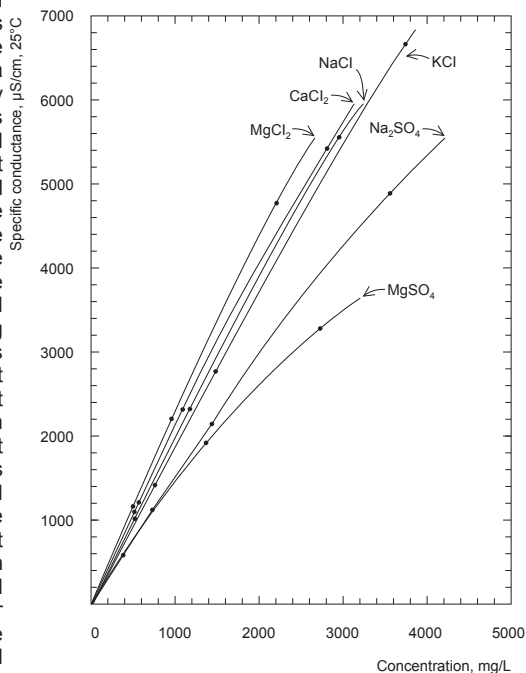

The SC450G measures conductivity. This value can be used to display TDS values on the main display. One should use the additional concentration table. Please refer to section 5.5 for concentration measurement. The unit for the TDS reading can be set to ppm or ppb.

Appendix 3 Calibration solutions for conductivity

NOTE

This section should be read in conjunction with the calibration section (Chapter 6) and the maintenance section (Chapter 7). The calibration (cell constant) of a sensor does not change unless the sensor is damaged.

It can also appear to change because of coating of the electrodes, or partial blockage. Because these changes should be handled as described in the maintenance section, it does not make sense to regularly recalibrate the SC450G.

A calibration check, however, is another matter. When the objective is clearly defined as a diagnostic exercise a regular check can bring an extra level of security and confidence to the measurement.

Sensor damage, and/or coatings can be difficult to see and the calibration check can confirm their presence, by a deviation from the known solution conductivity. The remedial action should be to clean the sensor, and carefully check for blockage or damage (not simply to recalibrate).

Higher conductivity solutions should be used where possible. The lower the conductivity of the test solution, the easier it is to contaminate. Carbon dioxide from the air can be quickly absorbed to cause an error. All containers must be suitably clean, and all materials suitably pure. Outside of a well-equipped laboratory these conditions are hard to meet.

Also note that the check must be performed with due regard to the cell constant of the sensor, as it limits the effective working range. The documentation provided with the sensor should be consulted to determine its maximum working value. By using a checking solution close to the upper range limit of the sensor, the detection of contamination is better. A slightly contaminated sensor may read perfectly at lower conductivity, but show significant errors at higher values. This is caused by the early onset of polarization, the factor that limits the upper range of the sensor in any case. Polarization is seen in contaminated sensors, and it is for this reason that there is a sophisticated polarization check built into the SC450G. Details of this diagnostic tool are found in the troubleshooting section (Chapter 8).

SC450G is programmed with the following table of conductivity of Potassium Chloride (KCl) solutions at 25°C. This is used in the Automatic Cell Constant setting calibration feature. (See chapter 6 on calibration) The table is derived from the Standards laid down in "International Recommendation No. 56 of the Organisation Internationale de Métrologie Legale".

Table 2 KCl values at 25 °C

mol/l	mg KCl/kg	Conductivity
0.001	74.66	0.1469 mS/cm
0.002	149.32	0.2916 mS/cm
0.005	373.29	0.7182 mS/cm
0.01	745.263	1.4083 mS/cm
0.1	7419.13	12.852 mS/cm
1.0	71135.2	111.31 mS/cm

If it is more convenient, the user may make solutions from Sodium Chloride (NaCl) with the help of the following relationship table. This table is derived from the IEC norm 60746-3.

Table 3 NaCl values at 25 °C

Weight %	mg NaCl/kg	Conductivity
0.001	10	21.4 $\mu\text{S/cm}$
0.003	30	64.0 $\mu\text{S/cm}$
0.005	50	106 $\mu\text{S/cm}$
0.01	100	210 $\mu\text{S/cm}$
0.03	300	617 $\mu\text{S/cm}$
0.05	500	1.03 mS/cm
0.1	1000	1.99 mS/cm
0.3	3000	5.69 mS/cm
0.5	5000	9.48 mS/cm
1	10000	17.6 mS/cm
3	30000	48.6 mS/cm
5	50000	81.0 mS/cm
10	100000	140 mS/cm

NOTE

For resistivity measurement the standard resistivity units of the calibration solution can be calculated as follows:

$$R = 1000/G \text{ (k}\Omega\cdot\text{cm if } G = \mu\text{S/cm)}$$

Example: 0.001% weight $R = 1000/21.4 = 46.7 \text{ k}\Omega\cdot\text{cm}$

Appendix 4 Sensor selection for the SC450G

Yokogawa supplies the following sensors, and their application is briefly described. All are compatible with the SC450G, and the user must be aware of the sensor configuration for 2 or 4 electrodes, in order to set the converter correctly.

SC42-SP34 (&SX42-SX34) cc = 0.01 cm⁻¹ 2-electrode sensor

This sensor is the first choice for pure and ultra pure water measurements. From 0.055 $\mu\text{S/cm}$ up to 100 $\mu\text{S/cm}$ this is a perfect choice. The measuring range extends to at least 1000 $\mu\text{S/cm}$, but there are better choices in that range.

Almost exclusively used in flow fittings and sub-assemblies. FF40 and FS40. (The -SX sensors are screwed or flanged direct into the process pipework or tanks.)

SC4A-S(T)-XX-002..... cc = 0.02 cm⁻¹ 2-electrode sensor

This sensor is a good choice for pure and ultra pure water measurements. From 0.055 $\mu\text{S/cm}$ up to 50 $\mu\text{S/cm}$ this is a good choice. The measuring range extends to 500 $\mu\text{S/cm}$, but there are better choices in that range. The "SC4A-" sensors make up a range that use compression adapters or specialized fittings, including retractable.

SC42-SP24 (&SX42-SX24) cc = 0.1cm⁻¹ 2-electrode sensor

This sensor should be used for clean and pure water measurements. From 0.2 $\mu\text{S/cm}$ up to 1 mS/cm the sensor is fine, with measurement up to 10mS/cm possible, but there are better choices in that range. Mounting of these sensors is as for the-SP(X)34 series.

SC4A-S(T)-XX-010..... cc = 0.1 cm⁻¹ 2-electrode sensor

This sensor is a good choice for clean water measurements. From 0.5μS/cm up to 200μS/cm this is a good choice. The measuring range extends to 2000μS/cm, but there are better choices in that range. The “SC4A-” sensors make up a range that uses compression adapters or specialized fittings, including retractable.

SC42-EP15(D) cc = 1 cm⁻¹ 2-electrode sensor

This sensor is intended as a handy, short sensor. It is easy to fit in a branch (tee) on a pipeline, and is good for measurements where the precision is less critical than a convenient installation. The D version is particularly suited to food applications because of its cleanability. Range of application is from 10μS/cm to 10mS/cm.

SC42-EP14 cc = 1 cm⁻¹ 2-electrode sensor

Clean cooling and process water applications are where this sensor is used. The best range of application is 10μS/cm to 10mS/cm. It is better suited to flow through installations in FS40 and FF40 adapters and fittings, but it can also be used in dip tubes - FD40.

SC42-EP18 cc = 1 cm⁻¹ 4-electrode sensor

Cooling and process water applications are where this sensor is used, including light fouling. The best range of application is 100μS/cm to 100mS/cm. The four-electrode system copes with some contamination from the process, and eliminates the tendency for polarization to occur at the higher conductivity. It is better suited to flow through installations in FS40 and FF40 adapters and fittings, but it can also be used in dip tubes - FD40.

SC42-EP04 cc = 10 cm⁻¹ 2-electrode sensor

This sensor is in the program for historical reasons. It makes little sense to select this sensor for new applications.

It was used mostly for process water and light process solutions. The operating range can be 1 to 100 mS/cm with higher readings having a very high risk of polarization. The SC42-EP18 or the SC42-EP08 (4-el sensors) covers these ranges with much greater certainty of avoiding polarization.

SC42-EP08 cc = 10 cm⁻¹ 4-electrode sensor

Process applications are where this sensor is used, including light fouling. The best range of application is 1mS/cm to 500mS/cm. The four-electrode system copes with some contamination from the process, and eliminates the tendency for polarization to occur at the higher conductivity. The upper limit is determined more often by chemical compatibility. The epoxy material is attacked by many of the chemicals that are present in high conductivity solutions. It is better suited to flow through installations in FS40 and FF40 adapters and fittings, but it can also be used in dip tubes - FD40.

SC42-TP08 (FP08) cc = 10 cm⁻¹ 4-electrode sensor

These sensors are for extreme applications. The PTFE or the PVDF used for the body of the sensor gives good chemical resistance for the strongly corrosive applications. These sensors are intended for use in ranges 10mS to 1000mS/cm. Careful selection of the holder is needed. The PVDF sub-assembly is an obvious choice for the SC42-FP08, and the PP flow fitting often has sufficient corrosion resistance for the application. In any case selection must be done with due regard to the process conditions.

The 2-electrode versions (SC42-T(F)P04) do exist, but like the epoxy version (SC42-EP04) they should be discounted for new applications.

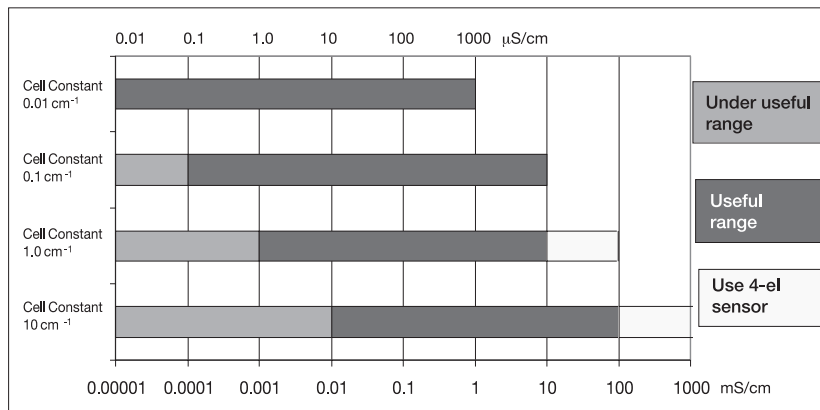

Appendix 5 How to enter the cell constant for the SC21□G, SC8SG, and SC4AJ

When install a new sensor, or replace a new one, put the cell constant manually as below.

- (1) In the case that the only cell constant is mentioned on the text plate of the sensor (SC211G, SC8SG, SC4AJ). Enter the cell constant directly.
- (2) In the case that the deviation of a nominal cell constant ($\pm X.X\%$) is mentioned on the text plate of the sensor (SC210G).

When the nominal cell constant is 5 cm^{-1} and the deviation ($\text{CORR.}\% = -1.1$) is mentioned:

The cell constant to be entered is calculated as follows:

$$5 + 5 \times (-1.1/100) = 4.945$$

Enter the cell constant of 4.945 cm^{-1} .

Appendix 6 HART HHT (275/375) menu structure

Those items with asterisks(*) appear or display each content variously depending on the selection of sensor type, measure type, output type and others.

Online menu	Level 1 menu	Level 2 menu	Level 3 menu	Level 4 menu
Process values	Primary value (SC/Conc.) Secondary value (Temp.) Tertiary value (SC/Cond)*			

Online menu	Level 1 menu	Level 2 menu	Level 3 menu	Level 4 menu
Zoom	Zoom sensor	Fact CC Adj CC Method SC1 Method SC2* Pol% Ohms USP%		
	Zoom outputs	mA1 value mA2 value S1 perc. S2 perc. S3 perc. S4 perc.		
	Zoom device	Serial number (*1) Software Revision Device Revision DD Revision		
	Logbook		Sensor data	Calibration Sensor Pred.Maint
Output data			Settings mA1 mA2 S1 S2 S3 S4	
Most appl. Error	Error description / remedy CC Calibration SC1 CC Calibration SC2 Air Calibration Sample calibration SC1 Sample calibration SC2 TC Calibration SC1* TC Calibration SC2* Temp. Calibration			
Calibration				
Hold Instrument	Hold Instrument Hold Outputs Hold Off			

Online menu	Level 1 menu	Level 2 menu	Level 3 menu	Level 4 menu
Commissioning	Measurement setup	Meas Configure sensor	Sensor type Meas unit Fact CC Measure*	
		Temp settings	Temp sensor Temp unit	
		Temp compensation	Temp comp Man value* Ref temp Method SC1 TC SC1* Matrix SC1* Method SC2* TC SC2* Matrix SC2*	
		Calib. settings	Air adjust limit cc hi limit cc lo limit Stab time cal interval	
		Concentration	Additional table* Conc table unit*	
	Output setup	mA1 setup mA2 setup (similar to mA1)	Type = control func Process parameter PID SP PID Rng PID dir PID MR* PID I-time* PID D-time* Burn Expiry time	Type = output func Process parameter Lin 0%* Lin 100%* Burn Damping time Type = simulate func Sim. Perc. Type = Off
		S1 setup S2 setup (similar to S1) S3 setup (similar to S1) S4 setup (similar to S1)	Type = control func Process parameter Expiry time PID SP PID Rng PID dir PID MR* PID I-time* PID D-time* Analog output DC period time* max. pulse freq.* Type = fail func	Type = alarm func Process parameter alarm SP alarm dir. alarm hyst. alarm delay expiry time Type = simulate func on/off* percentage* Type = hold func Type = Off
		HOLD setup	HOLD L/F mA1 fixed* mA2 fixed* Hold during cal	
		Input contact	Configure Input contact	

Online menu	Level 1 menu	Level 2 menu	Level 3 menu	Level 4 menu
	Error config	Configure error Off/Warn/Fail set kimits		
	Logbook config	Sensor logbook mA logbook Contact logbook Erase logbook Warn logbook full	Calibration Sensor Predictive. Maint. All logbooks	
Loop test (*2) Basic setup	Tag Distributor Model Device information	Date Descriptor Message Poll addr Num resp preams		
Review	Model Distributor Write protect Manufacturer Dev id Tag Descriptor Message Date Universal rev Fld dev rev Software rev Poll addr Num req preams			

(*1): A part of the HART device ID (descriptor)

(*2): Make sure to exit/cancel the loop test before proceeding to a measurement.

NOTE

HART protocol DD files can be downloaded by following URL.

<https://www.yokogawa.com/library/documents-downloads/software/>

Go to the URL above and enter "SC450."

Appendix 7 Control drawing for FM approval

Model: PH450G, SC450G, ISC450G Date: February 28, 2007

7. Drawings

7.1 Control Drawing

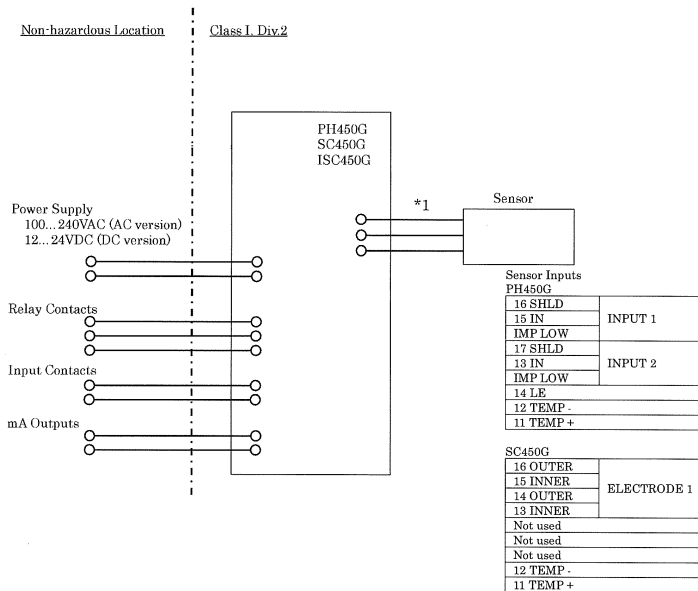

*1 Noncendive field wiring parameters for Sensor input

Model	Vt(V)	It(mA)	Ca(μ F)	La(mH)
PH450G	11	149	7.6	2.9mH
SC450G	11	842	7.6	91 μ H

WARNING

- Substitution of components may impair suitability for Division 2
- Do not remove or replace while circuit is live unless area is know to be non-hazardous
- Explosion Hazard – Do not disconnect equipment unless area is know to be non-hazardous
- Do not reset circuit breaker unless power has been removed from the equipment or the area is know to be non-hazardous
- Wiring for Division 2 must comply with NEC (NFPA 70) or Local Electrical Code as applicable.
- At Ta = +55 °C Maximum Current rating for Relay Contacts S1-S4 is 4A.
- At Ta = +40 °C Maximum Current rating for Relay Contacts S1-S4 is 5A.
- In case of using cable glands in Outdoor location, they shall be UV rated or made of metal.

Rev.4: August 13, 2007 S. Matsumura

Doc. No.: NFM016-A9 P.1
 Drawing: S. Matsumura
 Approved: K. Masuki

Yokogawa Electric Corporation

NFM016

Blank Page

Customer Maintenance Parts List

Model SC450G Conductivity Converter

[Style: S2]

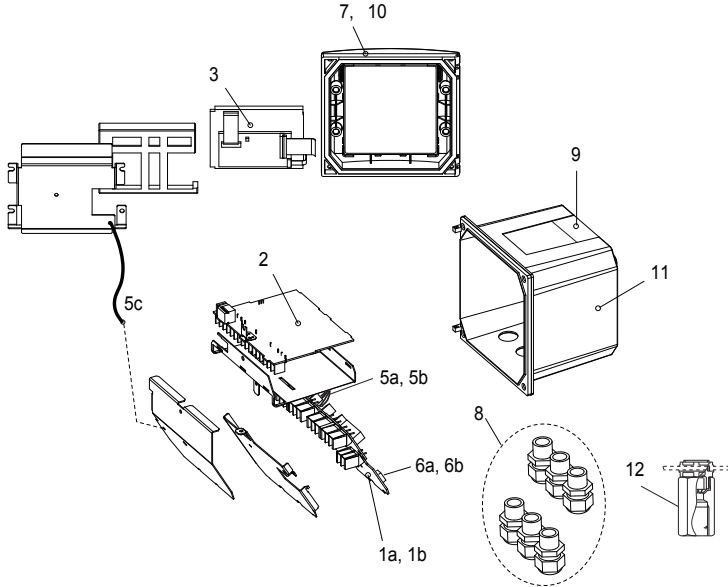

<u>Item</u>	<u>Part No.</u>	<u>Qty</u>	<u>Description</u>
*1a	K9676GA	1	Power board assembly AC version
*1b	K9676HA	1	Power board assembly DC version
*2	K9677EB	1	Main board assembly SC version
*3	K9676MA	1	LCD module
*5a	K9676MX	1	Cable assembly (3 core)
*5b	K9676MW	1	Cable assembly (10 core)
*5c	K9676MY	1	Cable assembly (shield)
*6a	A1108EF	1	Fuse AC version (1 pcs.)
*6b	A1111EF	1	Fuse DC version (1 pcs.)
*7	K9676BE	1	Cover assembly without, screws and hinge pins
8	K9676BU	1	Cable glands assembly (6 pcs. M20)
9	K9676DL	1	Stainless tagplate blank
10	K9676BT	1	Screw assembly to fix cover (M4 screws, washer, O-ring, hinge pins)
*11	K9676CM	1	Housing assembly polyurethan baked finish
12	—		Adapter assembly for conduit work
	K9171SU	1	For G1/2 screw when /AFTG specified
	K9316AF	1	For 1/2NPT screw when /ANSI specified
	K9676BC	1	For M20 screw when /AM20 specified

*) Do not exchange these parts. Call service personnel.

Pipe/Wall Mounting Hardware (Option code: /U)

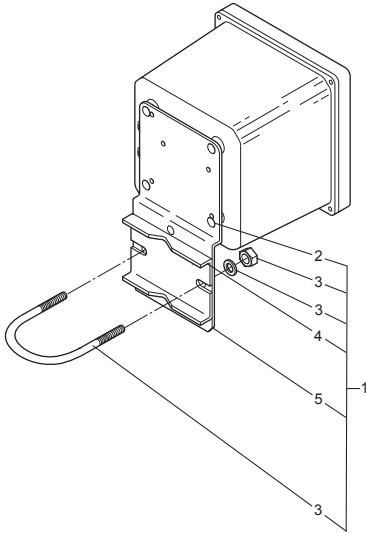

Panel Mounting Hardware (Option code: /PM)

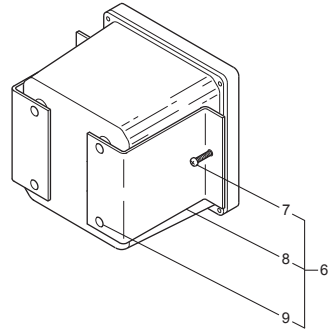

UNIVERSAL MOUNT SET (Option code : /UM) includes both "U" and "PM".

Awning Hood (Option code: /H5)

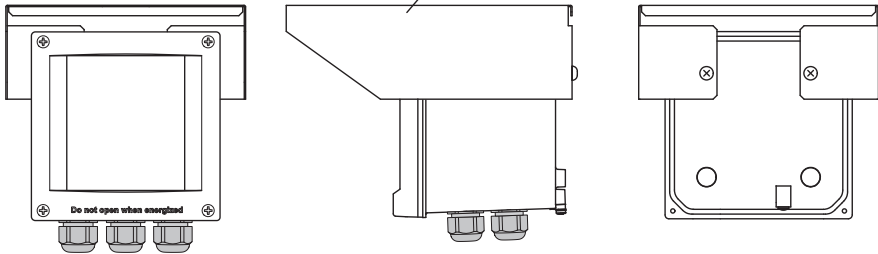

Item	Part No.	Qty	Description
1	K9171SS	1	Mounting Set (/U)
2	Y9608KU	4	Screw
3	D0117XL-A	1	U-Bolt Assembly
4	K9171SY	1	Plate
5	K9171SX	1	Bracket
6	K9171ST	1	Mounting Set (/PM)
7	Y9520LU	2	Screw
8	K9171SW	2	Bracket
9	Y9608KU	4	Screw
10	K9676BA	1	Awning hood assembly (/H5)

Revision Record

Manual Title : Model SC450G Conductivity Converter [Style: S2]

Manual Number : IM 12D08N05-01E

Nov. 2017 6th

Added explanation and attention (page 5-1).
Modified min. and max. values (pages 5-7, 5-9, 5-17).

Jul. 2017 5th

Added RoHS, All reviewed.

Mar. 2012 4th

PREFACE, Addition of "How to dispose the batteries"; p1, Addition of KC mark; p4, Some revision of O) Safety and EMC conforming standards (description for EMC revised), addition of KC mark; p9, Caution mark position on Section 3-3-1 changed; p15, HART communication mark added to Figure 4-1; p28, Some revision of Section 5-10. Water for Injection Monitoring, (USP 645 and EU 0169). Setting up EXA SC450 for WFI monitoring; p36, Some revision of Section 6-2 "Cell constant manual"; p38 to 39, Section 7-4 "Contrast adjustment" changed to "LCD adjustment", some caution added; p50, Some revision of Table 11.2 (Weight % deleted), and change of page; p55, Addition of "Appendix 4 How to enter the cell constant for the SC21`G, SC8SG, and SC4AJ."; p56 to 60, Appendix 5 changed to Appendix 6, and Appendix 6 changed to Appendix 7; Customer Maintenance Parts List CMPL 12D08N05-02E, revised to 4th Edition, some of illustration changed.

Aug. 2008 3rd

Back-side of cover, note illustration added; p3, Japanese added to display language; p4, option codes /U, /PM, /H5, /AFTG, /ANSI, /AM20 added to Model and codes; p5 to 6, Layout changed (Figure 3-1. moved and changed, because external dimensions for awning hood / H5, conduit adapter /AFTG, /ANSI, /AM20 added); p7, Figure 3-4 title modified; p8, conduit adapter work added to subsection 3-2-2; p9 to 11, Layout changed (descriptions after conduit adapter work moved.); p16, Subsection 4-3-13. Serial number --> HART ID. changed; p20 to 35 Layout changed (illustration of submenu screen placed on appropriate page); p41, some error corrected; p47, range value corrected; p49, some error corrected; p50, Table 11-2 modified; p53, C.C. range modified; p57, Note of HART protocol DD files URL added; Customer Maintenance Parts List CMPL12D08N05-02E revised to 2nd edition, because Part No. for option codes /U, /PM, /H5, /AFTG, /ANSI, /AM20 added.

Sep. 2007 2nd

Back-side of cover, note added; p1, FM approval description of Figure 1-1 changed; p7, some CAUTION of Figure 3-4 and the touchscreen added; p16, sec. 4-3-13 Serial number changed; p19, parameter values and some screen corrected; p21, Made some revisions (parameter values and some screen corrected; p23, parameter values and some screen corrected; p25, parameter values corrected; p29, parameter values corrected; p33, made some revisions; p37, some CAUTION of the touchscreen added; p39 to p42 Sec. 9 QUALITY INSPECTION inserted; p43 Sec. 10 SPARE PARTS section and page moved; p44 to p57 APPENDICES page moved (p53, note of serial number added; p57, APPENDIX 6, Control drawing for FM approval added); CMPL 12D08N05-02E, 1st Edition, made some revisions.

Jul. 2007 1st

Newly published

-
- Published by Yokogawa Electric Corporation
2-9-32 Nakacho, Musashino-shi, Tokyo 180-8750, JAPAN
<http://www.yokogawa.co.jp/an>
 - Printed by KOHOKU PUBLISHING & PRINTING INC.
-

Thank you for selecting Model SC450G [Style: S2] Conductivity / Resistivity Converter. The user's manual, IM 12D08N05-01E, 6th Edition, supplied with the product has been amended as follows. Please replace the corresponding pages in your copy with the revised pages.

★ **Revision on page 2-1, Input ranges**

Input ranges:

Conductivity: 0.000 μ S/cm to 2000 mS/cm
Minimum: **0 μ S/cm**
Maximum: **200 mS x C (overrange 2000 mS/cm)**
Resistivity: 0.0 Ω x cm to 1000 M Ω x cm

★ **Correction on the table at the bottom of page 5-13**

Menu	Parameter	Default values	Range	
			min.	max.
Errors1/3	Cond. High Limit	250 mS	> 0 ms	2.000 S
	Cond. Low Limit	1.000 μ S	> 0.00 μ S	2.000 S
	Res. High Limit	1.000 MΩ	> 0	10 M Ω
	Res. Low Limit	4.000 Ω	> 0	10 M Ω

★ **Deletion of a statement in 5.13 Logbook configuration, page 5-18.**
“EXAxt Configurator” software package is currently not available on the website.

5.13 Logbook configuration

● **General**

Logbook is available to keep an electronic record of ...

In “Configure Logbook” the user can select each item he is...

to be warned when the logbook is almost full. ~~The content of the logbook(s) can also be retrieved from the converter using the “EXAxt Configurator” software package which can be downloaded from the Yokogawa Europe website.~~