

UM12

Small sensor, great benefits

ULTRASONIC SENSORS

SICK
Sensor Intelligence.

Advantages



Virtually unlimited use – regardless of color, gloss, and transparency

SICK ultrasonic sensors perform measurement and detection tasks in a wide variety of application areas on colored, shiny, or transparent surfaces, which are particularly challenging for optical sensors. Even adverse ambient conditions such as dust, dirt, or fog hardly affect the measurement result. The broad detection range also allows for a large field to be monitored with just one sensor – with a measuring range of 13 mm to 8 m. No matter where they are: the ultrasonic sensors from SICK are at your side in any industry. The extensive product portfolio offers you a wide range of solutions for your application. See for yourself.

Find out more about the principle of operation of the ultrasonic sensors.

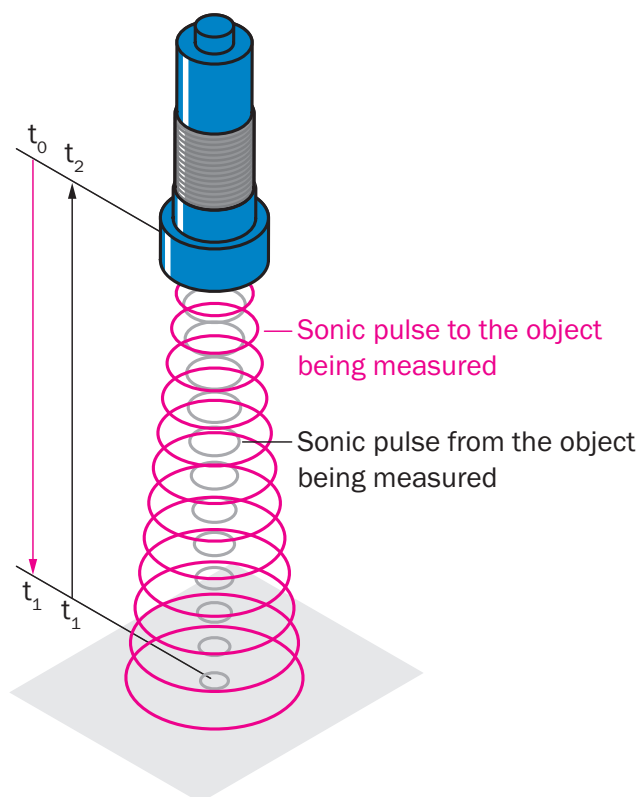

(Acoustic) time-of-flight measurement

The sensor emits an acoustic pulse that is reflected by the object being detected. The time required for the pulse to go from the sensor to the object and come back again is measured, evaluated and converted into the distance as follows.

Distance = speed of sound x total acoustic time of flight (t_2) / 2

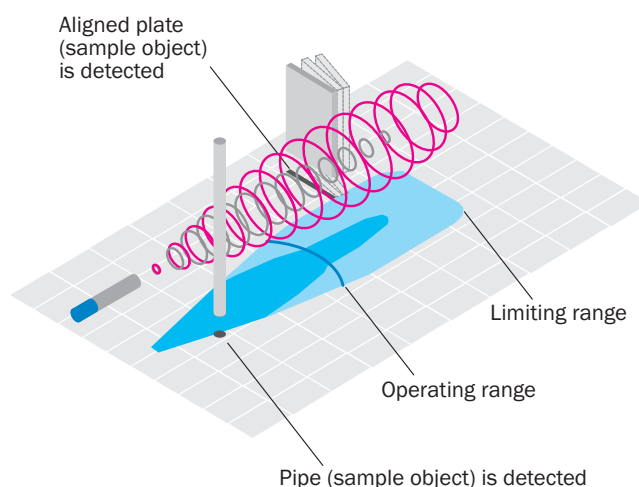

Scanning range of ultrasonic sensors

In general on ultrasonic sensors, the less sound the object being measured absorbs, the greater the possible scanning range. The operating range specifies the distance up to which measurement on common objects with sufficient operating reserves is possible. Under ideal conditions, the sensor can even be used up to its limiting range. Switch panels are used for ideal assessment of application capability. The dark blue area shown in these switch panels shows an example of the sensor's working range if a round rod is detected. The light blue area shows the maximum detection range (limiting range) which can be achieved under ideal conditions for easily detectable objects, such as the aligned plate given here. This area between the sensor and the measuring object should be kept free of other objects to prevent them from being detected accidentally. The detectability and detection range of an object depend on its reflective properties, size, and alignment. Depending on the application, the sensor may also be able to detect very small objects, e.g. metal wire.



Applications in focus

Ultrasonic sensors are true all-rounders. SICK ultrasonic sensors demonstrate their reliability and precision in virtually any application, from measuring distances or detecting solid, powdered, or liquid media. No matter the industry, no matter the application.

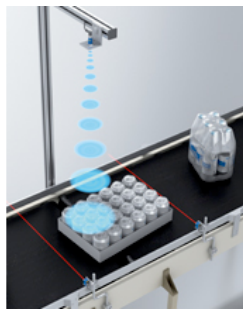
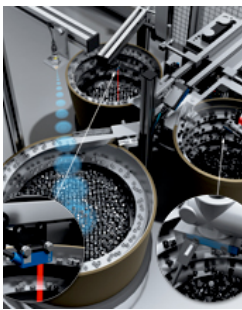

SICK ultrasonic sensors show their strengths in the contact-free detection of objects in all imaginable applications. These all-rounders reliably and precisely master all automation requirements on your processes.

SICK LifeTime Services

SICK's services increase machine and plant productivity, enhance the safety of people all over the world, provide a solid foundation for a sustainable business operation, and protect investment goods. In addition to its usual consulting services, SICK provides direct on-site support during the conceptual design and commissioning phases as well as during operation.

The range of services not only covers aspects like maintenance and inspection, but also includes performance checks as well as upgrades and retrofits. Modular or customized service contracts extend the service life of plants and therefore increase their availability. If faults occur or limit values are exceeded, these are detected at all times by the corresponding sensors and systems.

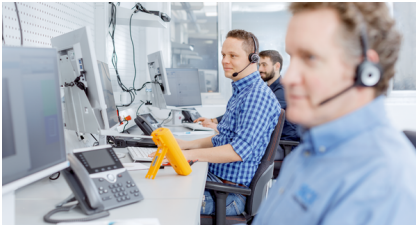
**Consulting and design**

Application-specific advice on the product, its integration and the application itself.

**commissioning and maintenance**

Application-optimized and sustainable — thanks to professional commissioning and maintenance by a trained SICK service technician.

**service contracts**

Extended warranty, SICK Remote Service, 24-hour helpdesk, maintenance, availability guarantees and other modular components can be individually combined on request.



Technical data overview

Measuring range	Operating range	20 mm ... 240 mm (depending on type)
	Limiting range	250 mm / 350 mm (depending on type)
Resolution		≥ 0.069 mm
Repeatability		± 0.15 %
Response time		24 ms ... 30 ms
		24 ms ... 30 ms ¹⁾
Output time		8 ms ... 10 ms (depending on type)
Switching frequency		30 Hz / 25 Hz (depending on type)
Analog output		4 mA ... 20 mA, ≤ 500 Ω ²⁾ 0 V ... 10 V, ≥ 100,000 Ω
Digital output		
	Type	PNP / NPN (depending on type)
Enclosure rating		IP65 / IP67
Sending axis		Straight

¹⁾ Subsequent smoothing of the analog output, depending on the application, may increase the response time by up to 200 %.

²⁾ For 4 mA ... 20 mA and $V_S \leq 20$ V max. load ≤ 100 Ω.

Product description

- The sensors in the UM12 product family impress with their compact dimensions in a rugged metal housing. Two sensing ranges up to 350 mm and four available output signals – analog current or voltage output, PNP or NPN switching output – maximize flexibility even where installation space is limited. Color-independent detection, high contamination tolerance, and outstanding background suppression deliver stable measurement results even under challenging conditions. With the UM12 ultrasonic sensor in an M12 housing, SICK is now able to offer the proven technology for any application.

At a glance

- Reliable measurement, regardless of material color, transparency, gloss, or ambient light
- Very short and rugged M12 metal housing
- Variants with PNP/NPN digital output or analog output
- Immune to dirt, dust, humidity, and fog
- Detection, measurement, or positioning with ultrasound technology
- Cable teach-in

Your benefits

- Very compact housing dimensions for straightforward machine integration
- Proven M12 housing design ensures compatibility with other technologies
- Analog variants in compact design for complex measuring tasks
- Rugged, one-piece metal housing ensures highest machine uptimes
- Teach-in via cable prevents unintentional sensor adjustment reducing machine downtime
- The sensor's immunity to external factors enables it to take accurate measurements even in dirty, dusty, humid, and foggy conditions
- Integrated temperature compensation ensures high measurement accuracy at any time for best process quality

Fields of application

- Detection, measurement or positioning of shiny and transparent materials
- Level control for fluid or bulk materials
- Diameter check for metal, paper, or plastic coils
- Continuous detection of fabrics and wire grids
- Detection of dark wooden boards or shiny metal parts

Ordering information

Other models and accessories → www.sick.com/UM12

- **Operating range, limiting range:** 20 mm ... 150 mm, 250 mm
- **Connection type:** male connector, M12, 4-pin
- **Communication interface:** -
- **Weight:** 15 g
- **Sending axis:** straight

Response time	Digital output	Type of analog output	Type	Part no.
24 ms	1 x NPN	-	UM12-1172251	6053543
	1 x PNP	-	UM12-1172211	6053542
24 ms ¹⁾	-	Current output	UM12-1172261	6053544
		Voltage output	UM12-1172271	6053545

¹⁾ Subsequent smoothing of the analog output, depending on the application, may increase the response time by up to 200 %.

- **Operating range, limiting range:** 40 mm ... 240 mm, 350 mm
- **Connection type:** male connector, M12, 4-pin
- **Communication interface:** -
- **Weight:** 15 g
- **Sending axis:** straight

Response time	Digital output	Type of analog output	Type	Part no.
30 ms	1 x NPN	-	UM12-1192251	6053547
	1 x PNP	-	UM12-1192211	6053546
30 ms ¹⁾	-	Current output	UM12-1192261	6053548
		Voltage output	UM12-1192271	6053549

¹⁾ Subsequent smoothing of the analog output, depending on the application, may increase the response time by up to 200 %.

SICK AT A GLANCE

SICK is one of the leading manufacturers of intelligent sensors and sensor solutions for industrial applications. A unique range of products and services creates the perfect basis for controlling processes securely and efficiently, protecting individuals from accidents and preventing damage to the environment.

We have extensive experience in a wide range of industries and understand their processes and requirements. With intelligent sensors, we can deliver exactly what our customers need. In application centers in Europe, Asia and North America, system solutions are tested and optimized in accordance with customer specifications. All this makes us a reliable supplier and development partner.

Comprehensive services complete our offering: SICK LifeTime Services provide support throughout the machine life cycle and ensure safety and productivity.

For us, that is “Sensor Intelligence.”

WORLDWIDE PRESENCE:

Contacts and other locations –www.sick.com