

Low Flow Transmitter EJX115A and EJA115E

IM 01C25K01-01E



Low Flow Transmitter EJX115A and EJA115E

IM 01C25K01-01E 13th Edition

Contents

1.	Introduction.....	1-1
	■ Regarding This Manual.....	1-2
	■ Trademarks	1-2
	1.1 Safe Use of This Product	1-3
	1.2 Warranty.....	1-5
2.	Handling Cautions.....	2-1
	2.1 Model and Specifications Check.....	2-1
	2.2 Unpacking.....	2-1
	2.3 Storage	2-2
	2.4 Selecting the Installation Location	2-2
	2.5 Pressure Connection.....	2-2
	2.6 Waterproofing of Cable Conduit Connections	2-3
	2.7 Restrictions on Use of Radio Transceivers	2-3
	2.8 Insulation Resistance and Dielectric Strength Test.....	2-3
	2.9 Installation of an Explosion-Protected Instrument.....	2-4
	2.9.1 FM Approval.....	2-4
	2.9.2 CSA Certification.....	2-6
	2.9.3 ATEX Certification.....	2-9
	2.9.4 IECEx Certification.....	2-13
	2.10 EMC Conformity Standards.....	2-18
	2.11 Pressure Equipment Directive (PED)	2-18
	2.12 EU RoHS Directive	2-19
	2.13 Safety Requirement Standards	2-19
3.	Component Names	3-1
4.	Installation.....	4-1
	4.1 Precautions	4-1
	4.2 Mounting	4-1
	4.2.1 How to install the position adjustable bracket.....	4-2
	4.3 Changing the manifold assembly	4-4
	4.4 Swapping the High/Low-pressure Side Connection.....	4-4
	4.5 Rotating Transmitter Section.....	4-4
	4.6 Changing the Direction of Integral Indicator	4-5

5.	Installing Impulse Piping	5-1
5.1	Process Piping Installation Precautions	5-1
5.1.1	Connecting Process Piping to the Transmitter	5-1
5.1.2	Routing the Process Piping	5-1
5.2	Process Piping Connection Examples	5-2
6.	Wiring	6-1
6.1	Wiring Precautions	6-1
6.2	Selecting the Wiring Materials	6-1
6.3	Connections of External Wiring to Terminal Box	6-1
6.3.1	Power Supply Wiring Connection	6-2
6.3.2	External Indicator Connection	6-2
6.3.3	Communicator Connection	6-2
6.3.4	Check Meter Connection	6-2
6.3.5	Status Output Connection	6-3
6.4	Wiring	6-3
6.4.1	Loop Configuration	6-3
6.4.2	Wiring Installation	6-4
6.5	Grounding	6-5
6.6	Power Supply Voltage and Load Resistance	6-5
7.	Operation	7-1
7.1	Preparation for Starting Operation	7-1
7.2	Zero Point Adjustment	7-3
7.3	Starting Operation	7-4
7.4	Shutting Down Operation	7-4
7.5	Transmitter Measurement Range (Determining Differential Pressure Range)	7-5
7.5.1	Determining the Differential Pressure Range	7-5
7.5.2	Example of Calculation	7-6
7.6	Venting or Draining Transmitter Pressure-detector Section	7-8
7.6.1	Draining Condensate	7-8
7.6.2	Venting Gas	7-8
7.7	Local Parameter Setting	7-9
7.7.1	Local Parameter Setting (LPS) Overview	7-9
7.7.2	Activating Local Parameter Setting	7-11
7.7.3	Parameter Setting Review	7-11
7.7.4	Loop Test Configuration	7-12
7.7.5	Tag Number Configuration	7-12
7.7.6	Pressure Unit Configuration	7-12
7.7.7	Pressure LRV/URV Configuration	7-13
7.7.8	Damping Time Constant Configuration	7-13

7.7.9	Output Mode Configuration	7-13
7.7.10	Display Out 1 Configuration.....	7-13
7.7.11	Re-range by applying actual pressure (LRV/URV).....	7-14
7.7.12	Device Information Display	7-14
7.7.13	Save or Cancel.....	7-14
7.7.14	Abort Configuration.....	7-15
	7.7.14.1 Abort Configuration (Menu).....	7-15
	7.7.14.2 Abort Configuration (Parameter).....	7-15
7.7.15	Local Parameter Setting Lock.....	7-15
7.7.16	Others	7-15
8.	Maintenance.....	8-1
8.1	Overview	8-1
8.2	Calibration Instruments Selection	8-1
8.3	Calibration	8-1
8.4	Disassembly and Reassembly	8-3
8.4.1	Replacing the Integral Indicator	8-3
8.4.2	Replacing the CPU Board Assembly	8-4
8.4.3	Replacing the Process Connector Gaskets.....	8-4
8.4.4	Cleaning Manifold Assembly and Replacing Orifice.....	8-5
8.4.5	Cleaning and Replacing the Capsule Assembly	8-6
8.5	Troubleshooting.....	8-7
8.5.1	Basic Troubleshooting	8-7
8.5.2	Troubleshooting Flowcharts.....	8-8
8.5.3	Alarms and Countermeasures.....	8-10
9.	General Specifications	9-1

Revision Information

When using the transmitters in a Safety Instrumented System application, refer to the Functional Safety Manual (Document No.: TI 01C25A05-01EN or TI 01C25A05-21EN for option code SLT) and follow the instructions and procedures described there. The document can be downloaded from the website of Yokogawa. (Website address: <https://www.yokogawa.com/solutions/products-platforms/field-instruments/>)

In order to satisfy the requirement of Safety Instrumented System, executing parameters setting is required. Please refer to the clause of “Setting Parameters” for setting range in the following manuals for the actual operation.

BRAIN: IM 01C25T03-01E
HART: IM 01C25T01-06EN

Please also refer to the contact output setting in the same clause. After installing the transmitter, confirm that the range and unit is set correctly. Calibration of the transmitters shall be done after completing the range setting.

1. Introduction

Thank you for purchasing the DPharp Low flow transmitter.

Your Pressure Transmitter was precisely calibrated at the factory before shipment. To ensure both safety and efficiency, please read this manual carefully before you operate the instrument.



NOTE

This manual describes the hardware configurations of the transmitters listed in below. For information on the software configuration and operation, please refer to either IM 01C25T03-01E for the BRAIN communication type, or IM 01C25T01-06EN for the HART communication type.

For FOUNDATION Fieldbus protocol type, please refer to IM 01C25T02-01E.
For PROFIBUS PA protocol type, please refer to IM 01C25T04-01EN.

For the specifications, external dimensions, and model, suffix and option codes of each product, please refer to the General Specifications sheet as listed in the Chapter 9.

Model	Style code
EJX115A	S1
EJA115E	S1, S2

To ensure correct use of this instrument, read both the hardware and software manuals thoroughly before use.



WARNING

When using the transmitters in a Safety Instrumented System application, refer to the Functional Safety Manual (Document No.: TI 01C25A05-01EN or TI 01C25A05-21EN for option code SLT) and follow the instructions and procedures described there. The document can be downloaded from the website of Yokogawa. (Website address:

<https://www.yokogawa.com/solutions/products-platforms/field-instruments/>)

In order to satisfy the requirement of Safety Instrumented System, executing parameters setting is required. Please refer to the clause of "Setting Parameters" for setting range in the following manuals for the actual operation.

BRAIN: IM 01C25T03-01E

HART: IM 01C25T01-06EN

Please also refer to the contact output setting in the same clause. After installing the transmitter, confirm that the range and unit is set correctly. Calibration of the transmitters shall be done after completing the range setting.



NOTE

When describing the model name as EJ□115□, it shows the applicability for both EJX115A and EJA115E.

■ Regarding This Manual

- This manual and the identification tag attached on the packing box are essential parts of the product. Please keep them in a safe place for future reference.
- This manual should be provided to the end user.
- The contents of this manual are subject to change without prior notice.
- All rights reserved. No part of this manual may be reproduced in any form without Yokogawa’s written permission.
- Yokogawa makes no warranty of any kind with regard to this manual, including, but not limited to, implied warranty of merchantability and fitness for a particular purpose.
- If any question arises or errors are found, or if any information is missing from this manual, please inform the nearest Yokogawa sales office.
- The specifications covered by this manual are limited to those for the standard type under the specified model number break-down and do not cover custom-made instruments.
- Please note that changes in the specifications, construction, or component parts of the instrument may not immediately be reflected in this manual at the time of change, provided that postponement of revisions will not cause difficulty to the user from a functional or performance standpoint.
- Yokogawa assumes no responsibilities for this product except as stated in the warranty.
- If the customer or any third party is harmed by the use of this product, Yokogawa assumes no responsibility for any such harm owing to any defects in the product which were not predictable, or for any indirect damages.
- The following safety symbols are used in this manual:



WARNING

Indicates a potentially hazardous situation which, if not avoided, could result in death or serious injury.



CAUTION

Indicates a potentially hazardous situation which, if not avoided, may result in minor or moderate injury. It may also be used to alert against unsafe practices.



IMPORTANT

Indicates that operating the hardware or software in this manner may damage it or lead to system failure.



NOTE

Draws attention to information essential for understanding the operation and features.

⎓ Direct current

⏏ Functional grounding terminal



Caution

This symbol indicates that the operator must refer to an explanation in the user’s manual in order to avoid the risk of injury or death of personnel or damage to the instrument.

■ Trademarks

- ‘DPharp’, ‘EJX’, ‘EJA’, ‘FieldMate’ and ‘BRAIN TERMINAL’ are registered trademarks of Yokogawa Electric Corporation. Company names and product names used in this material are registered trademarks or trademarks of their respective owners.
- In this manual, trademarks or registered trademarks are not marked with TM or ®.

1.1 Safe Use of This Product

For the safety of the operator and to protect the instrument and the system, please be sure to follow this manual's safety instructions when handling this instrument. If these instructions are not heeded, the protection provided by this instrument may be impaired. In this case, Yokogawa cannot guarantee that the instrument can be safely operated. Please pay special attention to the following points:

(a) Installation



WARNING

- This instrument may only be installed by an engineer or technician who has an expert knowledge of this device. Operators are not allowed to carry out installation unless they meet this condition.
- With high process temperatures, care must be taken not to burn yourself by touching the instrument or its casing.
- Never loosen the process connector nuts when the instrument is installed in a process. This can lead to a sudden, explosive release of process fluids.
- When draining condensate from the pressure detector section, take appropriate precautions to prevent the inhalation of harmful vapors and the contact of toxic process fluids with the skin or eyes.
- When removing the instrument from a hazardous process, avoid contact with the fluid and the interior of the meter.
- All installation shall comply with local installation requirements and the local electrical code.

(b) Wiring



WARNING

- The instrument must be installed by an engineer or technician who has an expert knowledge of this instrument. Operators are not permitted to carry out wiring unless they meet this condition.
- Before connecting the power cables, please confirm that there is no current flowing through the cables and that the power supply to the instrument is switched off.

(c) Operation



WARNING

- Wait 5 min. after power is turned off, before opening the covers.
- Do not open the cover in wet weather or humid environment. If the cover is opened, stated enclosure protection is not applicable.

(d) Maintenance



WARNING

- Please carry out only the maintenance procedures described in this manual. If you require further assistance, please contact the nearest Yokogawa office.
- Care should be taken to prevent the build up of dust or other materials on the display glass and the name plate. To clean these surfaces, use a soft, dry cloth.

(e) Explosion Protected Type Instrument



WARNING

- Users of explosion proof instruments should refer first to section 2.9 (Installation of an Explosion Protected Instrument) of this manual.
- The use of this instrument is restricted to those who have received appropriate training in the device.
- Take care not to create sparks when accessing the instrument or peripheral devices in a hazardous location.

(f) Modification



WARNING

- Yokogawa will not be liable for malfunctions or damage resulting from any modification made to this instrument by the customer.

(g) Product Disposal

- The instrument should be disposed of in accordance with local and national legislation/regulations.

(h) Authorized Representative in EEA and the importer into the EU/EEA market

- In relation to the CE Marking, The authorised representative for this product in the EEA (European Economic Area) is:
Yokogawa Europe B.V.
Euroweg 2, 3825 HD Amersfoort, The Netherlands
and the importer for this product into the EU/EEA market via the YOKOGAWA sales channel is:
Yokogawa Europe B.V.
Euroweg 2, 3825 HD Amersfoort, The Netherlands

(i) Control of Pollution Caused by the Product

This is an explanation for the product based on “Control of Pollution caused by Electronic Information Products” in the People’s Republic of China. The information is valid only in China.

产品中有害物质或元素的名称及含量

型号	部件名称	有害物质					
		铅 (Pb)	汞 (Hg)	镉 (Cd)	六价铬 (Cr(VI))	多溴联苯 (PBB)	多溴二苯醚 (PBDE)
EJX/EJA-E Series 差压/压力变送器	壳体	×	○	○	○	○	○
	膜盒组件	×	○	○	○	○	○
	基板组件	×	○	○	○	○	○
	电源连接线	×	○	○	○	○	○
○：表示该部件的所有均质材料中的有害物质的含量均在 GB/T26572 标准中所规定的限量以下。							
×：表示至少该部件的某些均质材料中的有害物质的含量均在 GB/T26572 标准中所规定的限量以上。							

环保使用期限：



该标识适用于 SJ /T11364 中所述，在中华人民共和国销售的电子电气产品的环保使用期限。

注) 该年数为“环保使用期限”，并非产品的质量保证期。

1.2 Warranty

- The warranty shall cover the period noted on the quotation presented to the purchaser at the time of purchase. Problems occurring during the warranty period shall basically be repaired free of charge.
- If any problems are experienced with this instrument, the customer should contact the Yokogawa representative from which this instrument was purchased or the nearest Yokogawa office.
- If a problem arises with this instrument, please inform us of the nature of the problem and the circumstances under which it developed, including the model specification and serial number. Any diagrams, data and other information you can include in your communication will also be helpful.
- The party responsible for the cost of fixing the problem shall be determined by Yokogawa following an investigation conducted by Yokogawa.
- The purchaser shall bear the responsibility for repair costs, even during the warranty period, if the malfunction is due to:
 - Improper and/or inadequate maintenance by the purchaser.
 - Malfunction or damage due to a failure to handle, use, or store the instrument in accordance with the design specifications.
 - Use of the product in question in a location not conforming to the standards specified by Yokogawa, or due to improper maintenance of the installation location.
 - Failure or damage due to modification or repair by any party except Yokogawa or an approved representative of Yokogawa.
 - Malfunction or damage from improper relocation of the product in question after delivery.
 - Reason of force majeure such as fires, earthquakes, storms/floods, thunder/lightening, or other natural disasters, or disturbances, riots, warfare, or radioactive contamination.

2. Handling Cautions

This chapter provides important information on how to handle the transmitter. Read this carefully before using the transmitter.

The transmitters are thoroughly tested at the factory before shipment. When taking delivery of an instrument, visually check them to make sure that no damage occurred during shipment.

Also check that all transmitter mounting hardware shown in figure 2.1 is included. If the transmitter is ordered without the mounting bracket and the process connector, the transmitter mounting hardware will not be included. After checking the transmitter, carefully repack it in its box and keep it there until you are ready to install it.

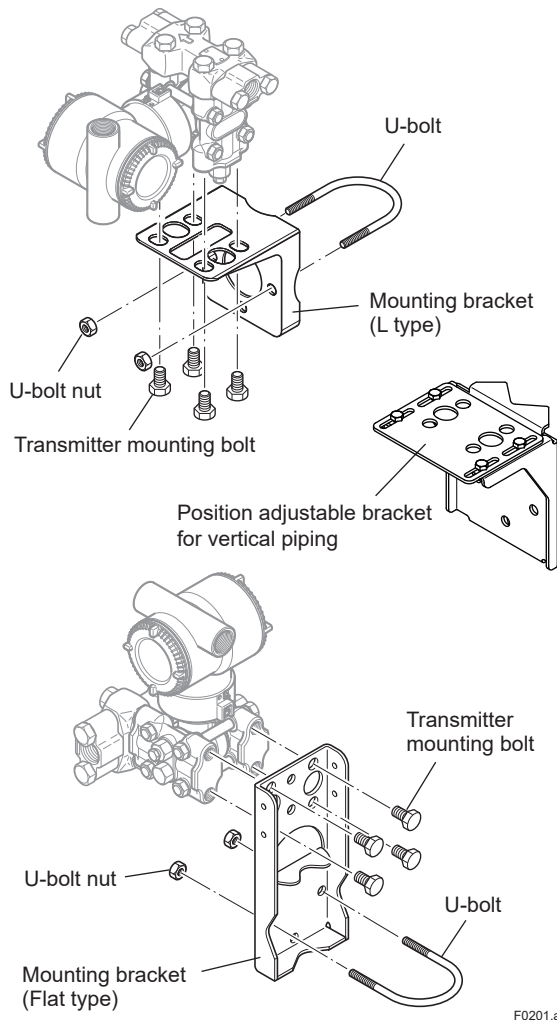

F0201.ai

Figure 2.1 Transmitter Mounting Hardware

2.1 Model and Specifications Check

The model name and specifications are written on the name plate attached to the case.

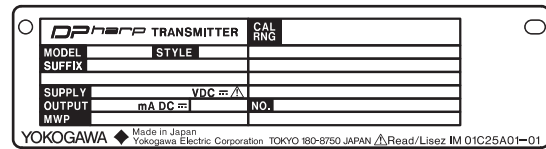

F0202.ai

Figure 2.2 Name Plate

2.2 Unpacking

Keep the transmitter in its original packaging to prevent it from being damaged during shipment. Do not unpack the transmitter until it reaches the installation site.

2.3 Storage

The following precautions must be observed when storing the instrument, especially for a long period.

- (a) Select a storage area which meets the following conditions:
- It is not exposed to rain or subject to water seepage/leaks.
 - Vibration and shock are kept to a minimum.
 - It has an ambient temperature and relative humidity within the following ranges.

Ambient temperature:

–40* to 85°C without integral indicator

–30* to 80°C with integral indicator

* –15°C when /HE is specified.

Relative humidity:

0% to 100% R.H.

Preferred temperature and humidity:

approx. 25°C and 65% R.H.

- (b) When storing the transmitter, repack it carefully in the packaging that it was originally shipped with.
- (c) If the transmitter has been used, thoroughly clean the chambers inside the cover flanges and integral flow orifice unit, so that there is no process fluid remaining inside. Before placing it in storage, also make sure that the pressure-detector is securely connected to the transmitter section.

2.4 Selecting the Installation Location

The transmitter is designed to withstand severe environmental conditions. However, to ensure that it will provide years of stable and accurate performance, take the following precautions when selecting the installation location.

- (a) Ambient Temperature
Avoid locations subject to wide temperature variations or a significant temperature gradient. If the location is exposed to direct sunlight or radiant heat from plant equipment, provide adequate shade, thermal insulation and/or ventilation.

- (b) Ambient Atmosphere
Do not install the transmitter in a corrosive atmosphere. If this cannot be avoided, there must be adequate ventilation as well as measures to prevent the leaking of rain water and the presence of standing water in the conduits.
- (c) Shock and Vibration
Although the transmitter is designed to be relatively resistant to shock and vibration, an installation site should be selected where this is kept to a minimum.
- (d) Installation of Explosion-protected Transmitters
An explosion-protected transmitters is certified for installation in a hazardous area containing specific gas types. See subsection 2.9 "Installation of an Explosion-Protected Transmitters."

2.5 Pressure Connection



WARNING

- Never loosen the process connector bolts when an instrument is installed in a process. The device is under pressure, and a loss of seal can result in a sudden and uncontrolled release of process fluid.
- When draining toxic process fluids that have condensed inside the pressure detector, take appropriate steps to prevent the contact of such fluids with the skin or eyes and the inhalation of vapors from these fluids.

The following precautions must be observed in order to safely operate the transmitter under pressure.

- (a) Make sure that all the process connector bolts are tightened firmly.
- (b) Make sure that there are no leaks in the impulse piping.
- (c) Never apply a pressure higher than the specified maximum working pressure.

2.6 Waterproofing of Cable Conduit Connections

Apply a non-hardening sealant to the threads to waterproof the transmitter cable conduit connections. (See figure 6.8, 6.9 and 6.10.)

2.7 Restrictions on Use of Radio Transceivers



IMPORTANT

Although the transmitter has been designed to resist high frequency electrical noise, if a radio transceiver is used near the transmitter or its external wiring, the transmitter may be affected by high frequency noise pickup. To test this, start out from a distance of several meters and slowly approach the transmitter with the transceiver while observing the measurement loop for noise effects. Thereafter use the transceiver outside the range where the noise effects were first observed.

2.8 Insulation Resistance and Dielectric Strength Test

Since the transmitter has undergone insulation resistance and dielectric strength tests at the factory before shipment, normally these tests are not required. If the need arises to conduct these tests, heed the following:

- (a) Do not perform such tests more frequently than is absolutely necessary. Even test voltages that do not cause visible damage to the insulation may degrade the insulation and reduce safety margins.
- (b) Never apply a voltage exceeding 500 V DC (100 V DC with an internal lightning protector) for the insulation resistance test, nor a voltage exceeding 500 V AC (100 V AC with an internal lightning protector) for the dielectric strength test.
- (c) Before conducting these tests, disconnect all signal lines from the transmitter terminals. The procedure for conducting these tests is as follows:

• Insulation Resistance Test

- 1) Short-circuit the + and – SUPPLY terminals in the terminal box. In case of 1 to 5 V output, short-circuit the SUPPLY+, SUPPLY – and A (VOUT +) terminals.
- 2) Turn OFF the insulation tester. Then connect the insulation tester plus (+) lead wire to the shorted SUPPLY terminals and the minus (–) leadwire to the grounding terminal.
- 3) Turn ON the insulation tester power and measure the insulation resistance. The voltage should be applied as briefly as possible to verify that the insulation resistance is at least 20 MΩ.
- 4) After completing the test and being very careful not to touch exposed conductors disconnect the insulation tester and connect a 100 kΩ resistor between the grounding terminal and the short-circuiting SUPPLY terminals. Leave this resistor connected at least one second to discharge any static potential. Do not touch the terminals while it is discharging.

• Dielectric Strength Test

- 1) Short-circuit the + and – SUPPLY terminals in the terminal box. In case of 1 to 5 V output, short-circuit the SUPPLY+, SUPPLY – and A (VOUT +) terminals.
- 2) Turn OFF the dielectric strength tester. Then connect the tester between the shorted SUPPLY terminals and the grounding terminal. Be sure to connect the grounding lead of the dielectric strength tester to the ground terminal.
- 3) Set the current limit on the dielectric strength tester to 25 mA, then turn ON the power and gradually increase the test voltage from '0' to the specified voltage.
- 4) When the specified voltage is reached, hold it for one minute.
- 5) After completing this test, slowly decrease the voltage to avoid any voltage surges.

2.9 Installation of an Explosion-Protected Instrument



NOTE

For FOUNDATION Fieldbus explosion protected type, please refer to IM 01C25T02-01E.
For PROFIBUS PA explosion protected type, please refer to IM 01C25T04-01EN.

If a customer makes a repair or modification to an intrinsically safe or explosionproof instrument and the instrument is not restored to its original condition, its intrinsically safe or explosionproof construction may be compromised and the instrument may be hazardous to operate. Please contact Yokogawa before making any repair or modification to an instrument.



CAUTION

This instrument has been tested and certified as being intrinsically safe or explosionproof. Please note that severe restrictions (e.g. IEC 60079-14) apply to this instrument's construction, installation, external wiring, maintenance and repair. A failure to abide by these restrictions could make the instrument a hazard to operate.



WARNING

Maintaining the safety of explosionproof equipment requires great care during mounting, wiring, and piping. Safety requirements also place restrictions on maintenance and repair. Please read the following sections very carefully.



WARNING

The range setting switch must not be used in a hazardous area.



IMPORTANT

For combined approval types
Once a device of multiple approval type is installed, it should not be re-installed using any other approval types. Apply a permanent mark in the check box of the selected approval type on the certification label on the transmitter to distinguish it from unused approval types.



IMPORTANT

All the blind plugs which accompany the EJX/EJA-E transmitters upon shipment from the factory are certified by the applicable agency in combination with those transmitters. The plugs which are marked with the symbols "∅ Ex" on their surfaces are certified only in combination with the EJX/EJA-E series transmitters.

2.9.1 FM Approval

a. FM Intrinsically Safe/Nonincendive for HART/BRAIN Protocol Type

Note 1. EJX/EJA-E Series pressure transmitters with optional code /FS1 are applicable for use in hazardous locations.

- Applicable Standard:
 - FM 3600:2011
 - FM 3610:2010
 - FM 3611:2004
 - FM 3810:2005
 - ANSI/ISA-60079-0-2009
 - ANSI/ISA-60079-11-2009
 - ANSI/ISA-61010-1-2004
 - NEMA 250:1991
- Rating
 - Intrinsically Safe for
 - Class I, II, III Division 1,
 - Groups A, B, C, D, E, F, G T4
 - Class I Zone 0 AEx ia IIC T4
 - Nonincendive for
 - Class I, II, III Division 2
 - Groups A, B, C, D, F, G T4
 - Class I, Zone 2 Group IIC T4
- Ambient temperature: -60 to 60°C
- Enclosure: Type 4X

Note 2. Installation

Installation should be in accordance with Control Drawing IFM022-A12.

Note 3. Specific conditions of use

Precautions shall be taken to minimize the risk from electrostatic discharge of painted parts. When the enclosure of the Pressure Transmitters is made of aluminum alloy, if it is mounted in Zone 0, it shall be installed such that, even in the event of rare incidents, an ignition source due to impact and/or friction sparks is excluded.

Note 4. Maintenance and Repair

Only personnel authorized by Yokogawa Electric Corporation can repair the equipment.

Model: EJX Series Date: October 22, 2003

Control Drawing

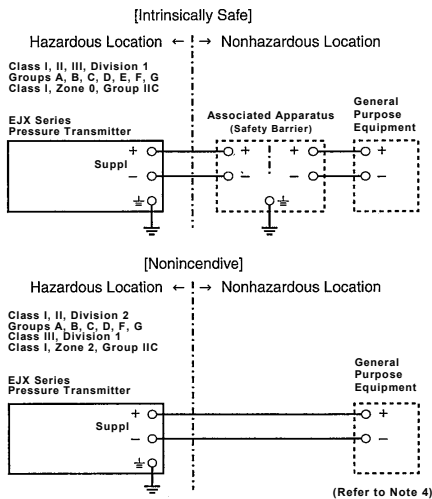

Rev.2: July 16, 2019 Doc. No.: IFM022-A12 P.1

Yokogawa Electric Corporation

Model: EJX Series Date: October 22, 2003

Specific conditions of use:
 - Precautions shall be taken to minimize the risk from electrostatic discharge of painted parts.
 - When the enclosure of the Pressure Transmitters is made of aluminum alloy, if it is mounted in Zone 0, it must be installed such that, even in the event of rare incidents, an ignition source due to impact and/or friction sparks is excluded.

Entity Parameters [Groups: A, B, C, D, E, F and G]

Vmax: 30 V
 Imax: 200 mA
 Pmax: 1 W
 Ci: 6 nF
 Li: 0 μH

Entity Parameters [Groups: C, D, E, F and G]

Vmax: 30 V
 Imax: 225 mA
 Pmax: 1 W
 Ci: 6 nF
 Li: 0 μH

Notes:

1. Installation must be in accordance with the National Electric Code (NFPA70), ANSI/ISA-RP12.06.01, and relevant local codes.
2. The Associated Apparatus must be FM-approved.
3. The following conditions must be satisfied.
 $V_{oc} \text{ (or } U_o) \leq V_{max}$
 $I_{sc} \text{ (or } I_o) \leq I_{max}$
 $P_o \leq P_{max}$
 $C_a \text{ (or } C_o) \geq C_i + C_{cable}$
 $L_a \text{ (or } L_o) \geq L_i + L_{cable}$
4. In case Nonincendive Field Wiring Concept is used for the interconnection, FM-approved Associated Nonincendive Field Wiring Apparatus, which meets the above conditions, must be used as the General Purpose Equipment.
5. The General Purpose Equipment connected to the Associated Apparatus must not use or generate a voltage more than Um of the Associated Apparatus.
6. The control drawing of the Associated Apparatus must be followed when installing the equipment.
7. Dust-tight conduit seals must be used when installed in Class II or Class III environments.
8. WARNING –ELECTROSTATIC CHARGE MAY CAUSE AN EXPLOSION HAZARD. AVOID ANY ACTIONS THAT CAUSE THE GENERATION OF ELECTROSTATIC CHARGE, SUCH AS RUBBING WITH A DRY CLOTH ON COATING FACE OF THE PRODUCT.
9. WARNING – SUBSTITUTION OF COMPONENTS MAY IMPAIR INTRINSIC SAFETY AND SUITABILITY FOR HAZARDOUS LOCATION

Rev.3: July 16, 2019 Doc. No.: IFM022-A12 P.2

Yokogawa Electric Corporation

b. FM Explosionproof Type

Caution for FM explosionproof type.

Note 1. EJX/EJA-E Series pressure transmitters with optional code /FF1 are applicable for use in hazardous locations.

- Applicable Standard: FM3600:2018, FM3615:2018, FM3810:2018, NEMA 250:2003, ANSI/UL 61010-1:2012, ANSI/UL 61010-2-30:2012
- Explosionproof for Class I, Division 1, Groups B, C and D.
- Dust-ignitionproof for Class II/III, Division 1, Groups E, F and G.
- Enclosure: Type 4X
- Temperature Class: T6
- Ambient Temperature: –40 to 60°C
- Supply Voltage: 42 V dc max.
 32 V dc max. (FOUNDATION Fieldbus and PROFIBUS PA type)
 9 to 28 V dc, 27 mW (Low Power type)
- Output signal: 4 to 20 mA
 15 mA (FOUNDATION Fieldbus and PROFIBUS PA type)
 1 to 5 V (Low Power type)

Note 2. Wiring

- All wiring shall comply with National Electrical Code ANSI/NFPA70 and Local Electrical Codes.
- When installed in Division 1, "FACTORY SEALED, CONDUIT SEAL NOT REQUIRED."
- Wiring connection for output signal code Q (Low Power type) shall follow the diagram below.

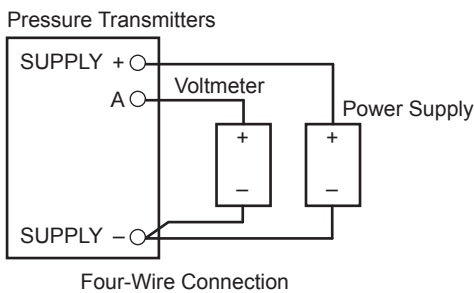
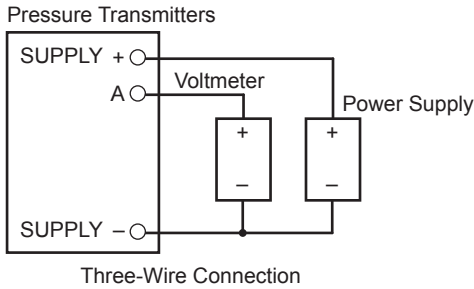

F0211.ai

Note 3. Operation

- Keep the "WARNING" nameplate attached to the transmitter.
WARNING: OPEN CIRCUIT BEFORE REMOVING COVER. FACTORY SEALED, CONDUIT SEAL NOT REQUIRED. INSTALL IN ACCORDANCE WITH THE USERS MANUAL IM 01C25.
- Take care not to generate mechanical sparking when accessing to the instrument and peripheral devices in a hazardous location.

Note 4. Maintenance and Repair

- The instrument modification or parts replacement by other than authorized representative of Yokogawa Electric Corporation is prohibited and will void Factory Mutual Explosionproof Approval.

c. FM Intrinsically Safe Type/FM Explosionproof Type

EJX/EJA-E Series pressure transmitters with optional code /FU1 or /V1U1 can be selected the type of protection (FM Intrinsically Safe or FM Explosionproof) for use in hazardous locations.

Note 1. For the installation of this transmitter, once a particular type of protection is selected, any other type of protection cannot be used. The installation must be in accordance with the description about the type of protection in this instruction manual.

Note 2. In order to avoid confusion, cross out unnecessary markings on the label other than the selected type of protection when the transmitter is installed.

2.9.2 CSA Certification

a. CSA Intrinsically Safe Type

Caution for CSA Intrinsically safe and nonincendive type. (Following contents refer to "DOC No. ICS013-A13")

Note 1. EJX/EJA-E Series differential, gauge, and absolute pressure transmitters with optional code /CS1 are applicable for use in hazardous locations

Certificate: 1606623

Applicable Standard:

- C22.2 No.0
- C22.2 No.94
- C22.2 No.157
- C22.2 No.213
- C22.2 No.61010-1
- C22.2 No.61010-2-030
- CAN/CSA-C22.2 60079-0:07
- CAN/CSA-E60079-11:02
- CAN/CSA-E60079-15:02
- CAN/CSA-C22.2 No.60529
- ANSI/ISA-12.27.01

[For Devison system]

- Intrinsically Safe for Class I, Division 1, Groups A, B, C & D, Class II, Division 1, Groups E, F & G, Class III, Division 1
- Nonincendive for Class I, Division 2, Groups A, B, C & D, Class II, Division 2, Groups F & G, Class III, Division 1
- Enclosure: Type 4X
- Temp. Code: T4
- Amb. Temp.: -50* to 60°C
* -15°C when /HE is specified.
- Process Temperature: 120°C max.

[For Zone system]

- Ex ia IIC T4, Ex nL IIC T4
- Ambient Temperature: -50* to 60°C
* -15°C when /HE is specified.
- Max. Process Temp.: 120°C
- Enclosure: IP66/IP67

Note 2. Entity Parameters

- Intrinsically safe ratings are as follows:
Maximum Input Voltage (Vmax/Ui) = 30 V
Maximum Input Current (Imax/Ii) = 200 mA
Maximum Input Power (Pmax/Pi) = 0.9 W
Maximum Internal Capacitance (Ci) = 10 nF
Maximum Internal Inductance (Li) = 0 µH
- Type “n” or Nonincendive ratings are as follows:
Maximum Input Voltage (Vmax/Ui) = 30 V
Maximum Internal Capacitance (Ci) = 10 nF
Maximum Internal Inductance (Li) = 0 µH
- Installation Requirements
Uo ≤ Ui, Io ≤ Ii, Po ≤ Pi,
Co ≥ Ci + Ccable, Lo ≥ Li + Lcable
Voc ≤ Vmax, Isc ≤ Imax,
Ca ≥ Ci + Ccable, La ≥ Li + Lcable
Uo, Io, Po, Co, Lo, Voc, Isc, Ca and La are parameters of barrier.

Note 3. Installation

- In any safety barreir used output current must be limited by a resistor ‘R’ such that Io=Uo/R or Isc=Voc/R.
- The safety barrier must be CSA certified.
- Input voltage of the safety barrier must be less than 250 Vrms/Vdc.
- Installation should be in accordance with Canadian Electrical Code Part I and Local Electrical Code.
- Dust-tight conduit seal must be used when installed in Class II and III environments.

- The instrument modification or parts replacement by other than authorized representative of Yokogawa Electric Corporation and Yokogawa Corporation of America is prohibited and will void Canadian Standards Intrinsically safe and nonincendive Certification.

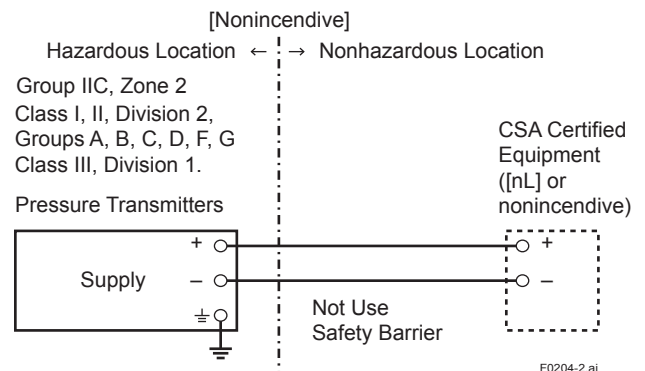
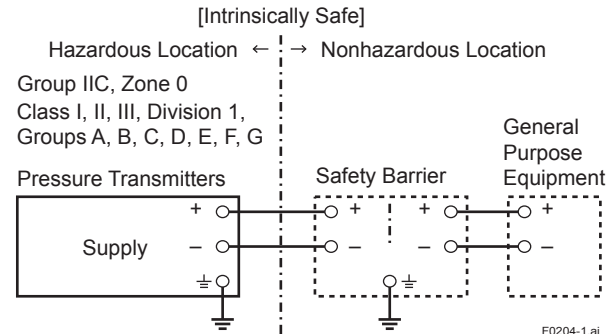

b. CSA Explosionproof Type

Caution for CSA explosionproof type.

Note 1. EJX/EJA-E Series pressure transmitters with optional code /CF1 are applicable for use in hazardous locations:

- Certificate: 2014354
- Applicable Standard:
C22.2 No. 25
C22.2 No. 30
CAN/CSA-C22.2 No. 94
CAN/CSA-C22.2 No. 61010-1-12
CAN/CSA-C22.2 No. 61010-2-030-12
CAN/CSA-C22.2 No. 60079-0:07
CAN/CSA-C22.2 No. 60079-1:07
CAN/CSA-C22.2 No. 60529
ANSI/ISA-12.27.01
- Explosion-proof for Class I, Groups B, C and D.
- Dustignition-proof for Class II/III, Groups E, F and G.

- Enclosure: Type 4X
- Temperature Code: T6...T4
- Ex d IIC T6...T4
- Enclosure: IP66/IP67
- Maximum Process Temperature: 120°C (T4), 100°C (T5), 85°C (T6)
- Ambient Temperature: -50* to 75°C (T4), -50* to 80°C (T5), -50* to 75°C (T6)
* -15°C when /HE is specified.
- Supply Voltage: 42 V dc max.
32 V dc max. (FOUNDATION Fieldbus and PROFIBUS PA type)
9 to 28 V dc, 27 mW (Low Power type)
- Output Signal: 4 to 20 mA dc
15 mA (FOUNDATION Fieldbus and PROFIBUS PA type)
1 to 5 V (Low Power type)

Note 2. Wiring

- All wiring shall comply with Canadian Electrical Code Part I and Local Electrical Codes.
- In hazardous location, wiring shall be in conduit as shown in the figure.
- WARNING:
A SEAL SHALL BE INSTALLED WITHIN 45cm OF THE ENCLOSURE.
UN SCELLEMENT DOIT ÊTRE INSTALLÉ À MOINS DE 45cm DU BOÎTIER.
- WARNING:
WHEN INSTALLED IN CL.I, DIV 2, SEAL NOT REQUIRED.
UNE FOIS INSTALLÉ DANS CL I, DIV 2, AUCUN JOINT N'EST REQUIS.

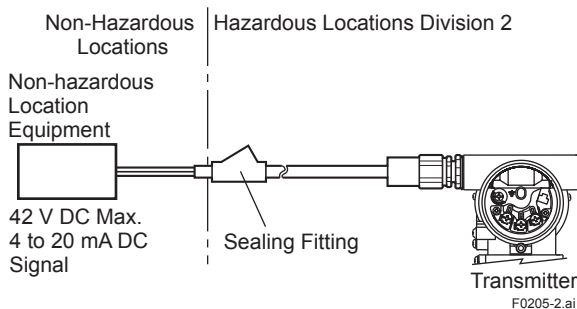
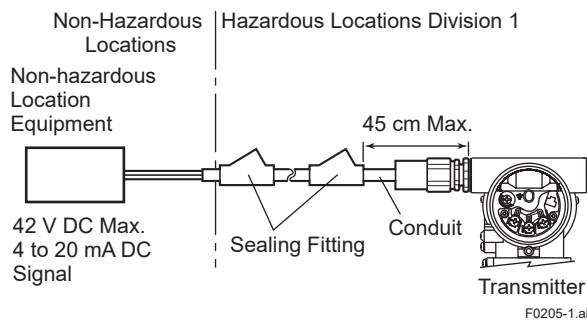

- All wiring shall comply with local installation requirements and local electrical code.
- In hazardous locations, the cable entry devices shall be of a certified flameproof type, suitable for the conditions of use and correctly installed.
- Unused apertures shall be closed with suitable flameproof certified blanking elements. (The plug attached is flameproof certified.)
- Wiring connection for output signal code Q (Low Power type) shall follow the diagram below.

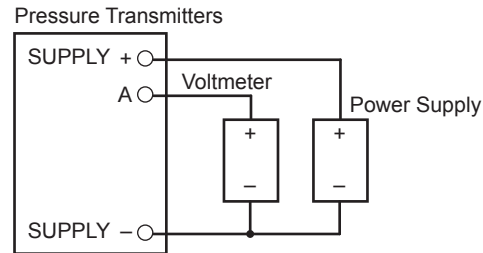

Three-Wire Connection

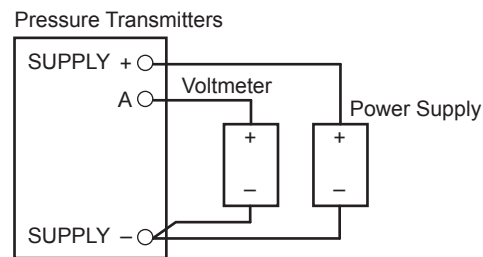

Four-Wire Connection

F0212.ai

Note 3. Operation

- WARNING:
AFTER DE-ENERGIZING, DELAY 5 MINUTES BEFORE OPENING.
APRÈS POWER-OFF, ATTENDRE 5 MINUTES AVANT D'OUVRIR.
- WARNING:
WHEN AMBIENT TEMPERATURE $\geq 65^{\circ}\text{C}$, USE THE HEAT-RESISTING CABLES $\geq 90^{\circ}\text{C}$.
QUAND LA TEMPÉRATURE AMBIANTE $\geq 65^{\circ}\text{C}$, UTILISEZ DES CÂBLES RÉSISTANTES À LA CHALEUR $\geq 90^{\circ}\text{C}$.
- Take care not to generate mechanical sparking when accessing to the instrument and peripheral devices in a hazardous location.

Note 4. Maintenance and Repair

- The instrument modification or parts replacement by other than authorized representative of Yokogawa Electric Corporation and Yokogawa Corporation of America is prohibited and will void Canadian Standards Explosionproof Certification.

c **CSA Intrinsically Safe Type/CSA Explosionproof Type**

EJX/EJA-E Series pressure transmitters with optional code /CU1 or /V1U1 can be selected the type of protection (CSA Intrinsically Safe or CSA Explosionproof) for use in hazardous locations.

Note 1. For the installation of this transmitter, once a particular type of protection is selected, any other type of protection cannot be used. The installation must be in accordance with the description about the type of protection in this instruction manual.

Note 2. For combined approval types, once a device of multiple approval type is installed, it should not be re-installed using any other approval types. Apply a permanent mark in the check box of the selected approval type on the certification label on the transmitter to distinguish it from unused approval types.



2.9.3 ATEX Certification

(1) Technical Data

a. ATEX Intrinsically Safe Ex ia

Caution for ATEX Intrinsically safe type.

Note 1. EJX/EJA-E Series pressure transmitters with optional code /KS21 for use in hazardous locations:

- Applicable standards:
EN IEC 60079-0, EN 60079-11
- Certificate number: DEKRA 11ATEX0228 X
- Specific Ex marking:
 II 1 G Ex ia IIC T4 Ga
 II 2 D Ex ia IIIC T85°C T100°C T120°C Db
- Ambient temperature:
 EPL Ga $-50^{\circ}\text{C} \leq T_a \leq +60^{\circ}\text{C}$
 EPL Db $-30^{\circ}\text{C} \leq T_a \leq +60^{\circ}\text{C}$
 EPL Db * $-15^{\circ}\text{C} \leq T_a \leq +60^{\circ}\text{C}$

- Process temperature:
 EPL Ga $-50^{\circ}\text{C} \leq T_p \leq +120^{\circ}\text{C}$
 EPL Db T120°C $-30^{\circ}\text{C} \leq T_p \leq +120^{\circ}\text{C}$
 T100°C $-30^{\circ}\text{C} \leq T_p \leq +100^{\circ}\text{C}$
 T85°C $-30^{\circ}\text{C} \leq T_p \leq +80^{\circ}\text{C}$
 EPL Db * T120°C $-15^{\circ}\text{C} \leq T_p \leq +120^{\circ}\text{C}$
 T100°C $-15^{\circ}\text{C} \leq T_p \leq +100^{\circ}\text{C}$
 T85°C $-15^{\circ}\text{C} \leq T_p \leq +80^{\circ}\text{C}$

* When FKM O-rings are used. (/HE is specified.)

- Enclosure: IP66/IP67 in accordance with EN IEC 60079-0
- Power supply: $\leq 30\text{ V}, \leq 21.6\text{ mA}$
- Dielectric strength:
 500 V AC, r.m.s., Terminals: to Enclosure
 1 min Supply +
 Supply -

Note 2. Specific condition of use





When the equipment is mounted in an area where the use of Category 1 G equipment is required, it shall be installed in such a way that, even in the event of rare incidents, an ignition source due to impact and/or friction sparks is excluded.

Precaution shall be taken to minimize the risk from electrostatic discharges or propagating brush discharges on the non-metallic parts (excluding glass parts) or coated parts of the equipment.

The dielectric strength of at least 500 V of the intrinsically safe circuits of the equipment is limited only by the overvoltage protection. From the safety point of view, the intrinsically safe circuit of the equipment shall be assumed to be connected to earth.

Note 3. Installation and erection

Cable entry devices suitable for the thread form and the size of the cable entries must be used, according to the following marking on the equipment.

Screw Size	Marking
ISO M20 × 1.5 female	 M
ANSI 1/2 NPT female	 A or  N or  W

F0218.ai

When installing the equipment, the selected Type of Protection should be ticked as follows.
 Ex ia IIC T4 Ga
 Ex ia IIIC T85°C T100°C T120°C Db
 See the control drawing.

Note 4. Use and setting-up (operation)

If the equipment is mounted in an area where explosive atmospheres may be present, it must be installed in such a way that the risk from electrostatic discharges and propagating brush discharges caused by rapid flow of dust are avoided.

Note 5. Maintenance and repair



WARNING

A modification of the equipment would no longer comply with the construction described in the certificate documentation.

Only personnel authorized by Yokogawa Electric Corporation can repair the equipment.

Yokogawa Electric Corporation		Model		EJX Series	
Title	Control drawing (General)				
No.	IKE045-A91	Page	1	Revision	0
Date	2020-08-07				

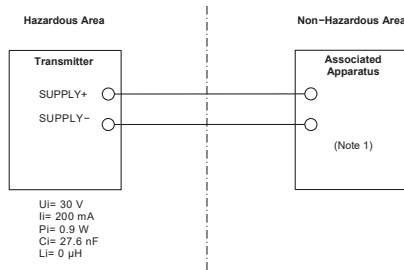

Notes:
1. Associated Apparatus must be a linear power source whose output current is resistively limited.

b. ATEX Flameproof Type

Caution for ATEX flameproof type.

Note 1. EJX/EJA-E Series pressure transmitters with optional code /KF22 are applicable for use in hazardous locations.

- No. KEMA 07ATEX0109 X
- Applicable Standard:
EN IEC 60079-0
EN 60079-1, EN 60079-31
- Type of Protection and Marking Code:

	II 2 G	<input type="checkbox"/>	Ex db IIC T6...T4 Gb
	II 2 D	<input type="checkbox"/>	Ex tb IIIC T85°C Db
- Enclosure: IP66 / IP67
- Temperature Class for gas-proof:
T6, T5, and T4
- Ambient Temperature for gas-proof:
-50 to 75°C (T6), -50 to 80°C (T5), and -50 to 75°C (T4)
- Process Temperature (Tp.) for gas-proof:
-50 to 85°C (T6), -50 to 100°C (T5), and -50 to 120°C (T4)
- Maximum Surface Temperature for dust-proof:
T85°C (Tamb.: -30* to 75°C, Tp.: -30* to 85°C)
* -15°C when /HE is specified.

Note 2. Electrical Data

- Supply voltage: 42 V dc max.
32 V dc max. (FOUNDATION Fieldbus and PROFIBUS PA type)
9 to 28 V dc, 27 mW (Low Power type)
9 to 30 V dc, 250 mW (RS485 Modbus Communication Type)
- Output signal: 4 to 20 mA
15 mA (FOUNDATION Fieldbus and PROFIBUS PA type)
1 to 5 V (Low Power type)
RS485 Modbus (RS485 Modbus Communication Type)

Note3. For combined approval types Once a device of multiple approval type is installed, it should not be re-installed using any other approval types. Apply a permanent mark in the check box of the selected approval type on the certification label on the transmitter to distinguish it from unused approval types.

Note 4. Installation

- All wiring shall comply with local installation requirement.
- In order to prevent the earthing conductor from loosening, the conductor must be secured to the terminal, tightening the screw with appropriate torque. Care must be taken not to twist the conductor.
- Cable glands, adapters and/or blanking elements with a suitable IP rating shall be of Ex d IIC/Ex tb IIIC certified by ATEX and shall be installed so as to maintain the specific degree of protection (IP Code) of the equipment.
- Wiring connection for output signal code Q (Low Power type) shall follow the diagram below.

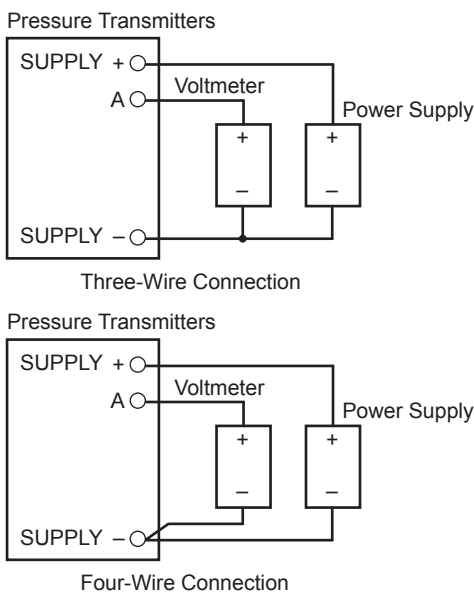

Note 5. Operation

- Keep the “WARNING” label attached to the transmitter.
WARNING: AFTER DE-ENERGIZING, DELAY 5 MINUTES BEFORE OPENING. WHEN THE AMBIENT TEMP. ≥ 65°C, USE HEAT-RESISTING CABLE AND CABLE GLAND ≥ 90°C.
- Take care not to generate mechanical sparking when accessing to the instrument and peripheral devices in a hazardous location.

Note 6. Maintenance and Repair

- **Warning:** When maintenance and repair are performed, confirm the following conditions and then perform works.
 Confirm the power supply is cut off and the voltage of power supply terminal is not supplied.
- Only personnel authorized by Yokogawa Electric Corporation can repair the equipment in accordance with the relevant standards: IEC / EN 60079-19 (Equipment repair, overhaul and reclamation) and IEC / EN 60079-17 (Electrical installation inspection and maintenance); otherwise the certification will be voided.

Note 7. Specific Conditions of Use



- Electrostatic charge may cause an explosion hazard. Avoid any actions that cause the generation of electrostatic charge, such as rubbing with a dry cloth on coating face of the product.
- In the case where the enclosure of the Pressure Transmitter is made of aluminium, if it is mounted in an area where the use of category 2D apparatus is required, it shall be installed in such a way that the risk from electrostatic discharges and propagating brush discharges caused by rapid flow of dust is avoided.
- The flame paths differ from the standard values in EN 60079-1. Repair of the equipment is only allowed when done by the manufacturer or an authorised representative.
- The fasteners used to fasten the transmitter enclosure onto the sensor capsule is special fastener, and the property class of it is A2-50(A4-50) or more.
- For transmitters with a membrane made of titanium, ignition hazard due to impact and friction on the membranes shall be avoided.
- Maximum Surface Temperature for dust-proof: T85°C (Tamb.: -30* to 75°C, Tp.: -30* to 85°C)
 * -15°C when /HE is specified.

c. ATEX Intrinsically Safe Type/ATEX Flameproof Type

EJX/EJA-E Series pressure transmitters with optional code /KU22 or /V1U1 can be selected the type of protection ATEX Flameproof, Intrinsically Safe. Ex ia, or Ex ic for use in hazardous area.

Note 1. For the installation of this transmitter, once a particular type of protection is selected, any other type of protection cannot be used. The installation must be in accordance with the description about the type of protection in this user’s manual.

Note 2. For combined approval types Once a device of multiple approval type is installed, it should not be re-installed using any other approval types. Apply a permanent mark in the check box of the selected approval type on the certification label on the transmitter to distinguish it from unused approval types.

• ATEX Intrinsically Safe Ex ic

Caution for ATEX intrinsically safe Ex ic

- Applicable standards: EN IEC 60079-0, EN 60079-11
- Specific Ex Marking: II 3 G \square Ex ic IIC T4 Gc
- Ambient temperature: $-30^{\circ}\text{C} \leq \text{Ta} \leq +60^{\circ}\text{C}$
 $-15^{\circ}\text{C} \leq \text{Ta} \leq +60^{\circ}\text{C} *$
- Process temperature: $-30^{\circ}\text{C} \leq \text{Tp} \leq +120^{\circ}\text{C}$
 $-15^{\circ}\text{C} \leq \text{Tp} \leq +120^{\circ}\text{C} *$
* When FKM O-rings are used. (/HE is specified.)
- Enclosure: IP66
- Pollution degree: 2
- Overvoltage category: I
- Power supply: $\leq 30 \text{ V}$, $\leq 21.6 \text{ mA}$
- Dielectric strength (Note 3)
 $500 \text{ V AC, r.m.s.,}$ Terminals: to Enclosure
 1 min Supply +
 Supply -
- Specific condition of use:
Precaution shall be taken to minimize the risk from electrostatic discharges on the non-metallic parts (excluding glass parts) or coated parts of the equipment.
The dielectric strength of at least 500 V of the intrinsically safe circuits of the equipment is limited only by the overvoltage protection.

From the safety point of view, the intrinsically safe circuit of the equipment shall be assumed to be connected to earth.

- Installation and erection:
Cable entry devices suitable for the thread form and the size of the cable entries must be used, according to the following marking on the equipment.

Screw Size	Marking
ISO M20 × 1.5 female	\triangle M
ANSI 1/2 NPT female	\triangle A or \triangle N or \triangle W

F0218.ai

When installing the equipment, the selected Type of Protection should be ticked as follows.

- Ex ic IIC T4 Gc
- Ex ia IIC T4 Ga
- Use and setting-up (operation):
If the pressure transmitter is mounted in an area where explosive atmospheres may be present, it must be installed in such a way that the risk from electrostatic discharges.
- Maintenance and repair:



WARNING

A modification of the equipment would no longer comply with the construction described in the certificate documentation.

Only personnel authorized by Yokogawa Electric Corporation can repair the equipment.

Yokogawa Electric Corporation		Model	EJX Series				
Title	Control drawing		Prepared by	M. Inatomi			
			Approved by	D. Harada			
No.	IKE046-A70	Page	1	Revision	2	Date	2020-09-02
Revised pages	T-2						

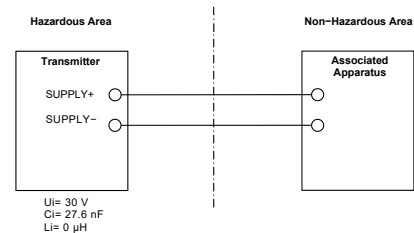

(2) Electrical Connection

A mark indicating the electrical connection type is stamped near the electrical connection port.

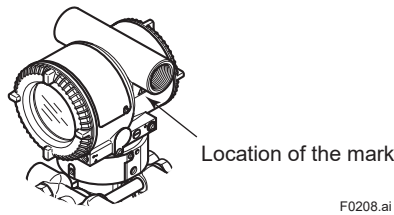

F0208.ai

(3) Name Plate

• Name plate

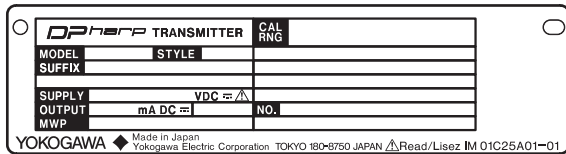

• Tag plate for flameproof type

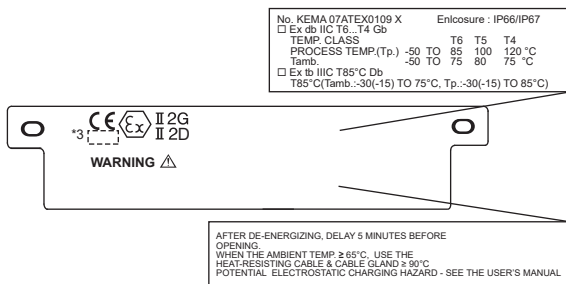

• Tag plate for intrinsically safe type EX ia

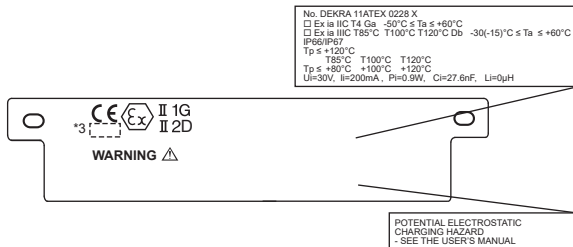

• Tag plate for ATEX intrinsically safe or ATEX flameproof

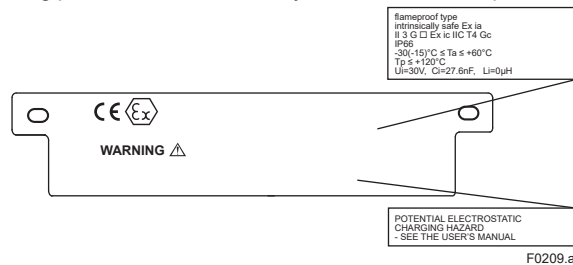

F0209.ai

- MODEL: Specified model code.
- STYLE: Style code.
- SUFFIX: Specified suffix code.
- SUPPLY: Supply voltage.
- OUTPUT: Output signal.
- MWP: Maximum working pressure.
- CAL RNG: Specified calibration range.
- NO.: Serial number and year of production*1.

TOKYO 180-8750 JAPAN:

The manufacturer name and the address*2.

*1: The first digit in the three numbers next to the nine letters of the serial number appearing after "NO." on the nameplate indicates the year of production. The following is an example of a serial number for a product that was produced in 2010:

91K819857 032

The year 2010

*2: "180-8750" is a zip code which represents the following address.

2-9-32 Nakacho, Musashino-shi, Tokyo Japan

*3: The identification number of Notified Body.

2.9.4 IECEx Certification

EJX Series pressure transmitters with optional code /SU21 or /SU22 can be selected the type of protection (IECEx Intrinsically Safe Ex ia, Ex ic or flameproof) for use in hazardous locations.

Note 1. For the installation of this transmitter, once a particular type of protection is selected, any other type of protection cannot be used. The installation must be in accordance with the description about the type of protection in this instruction manual.

Note 2. For combined approval types, once a device of multiple approval type is installed, it should not be re-installed using any other approval types. Apply a permanent mark in the check box of the selected approval type on the transmitter to distinguish it from unused approval types.

a. IECEx Intrinsically Safe Ex ia

Caution for IECEx Intrinsically safe Ex ia.

Note 1. EJX/EJA-E series pressure transmitters with optional code /SU21 or /SU22 are applicable for use in hazardous locations

- Applicable standards: IEC 60079-0, IEC 60079-11
- Certificate number: IECEx DEK 11.0081X
- Specific Ex marking: Ex ia IIC T4 Ga
- Ambient temperature: -50°C ≤ Ta ≤ +60°C
- Process temperature: -50°C ≤ Tp ≤ +120°C
- Enclosure: IP66/IP67 in accordance with IEC 60079-0
- Power supply: ≤ 30 V, ≤ 21.6 mA
- Dielectric strength: 500 V AC, r.m.s., Terminals: to Enclosure
 1 min Supply +
 Supply -

Note 2. Specific condition of use

When the equipment is mounted in an area where the use of EPL Ga equipment is required, it shall be installed in such a way that, even in the event of rare incidents, an ignition source due to impact and/or friction sparks is excluded.

Precaution shall be taken to minimize the risk from electrostatic discharges or propagating brush discharges on the non-metallic parts (excluding glass parts) or coated parts of the equipment.

The dielectric strength of at least 500 V of the intrinsically safe circuits of the equipment is limited only by the overvoltage protection. From the safety point of view, the intrinsically safe circuit of the equipment shall be assumed to be connected to earth.

Note 3. Installation and erection

Cable entry devices suitable for the thread form and the size of the cable entries must be used, according to the following marking on the equipment.

Screw Size	Marking
ISO M20 × 1.5 female	⚠M
ANSI 1/2 NPT female	⚠A or ⚠N or ⚠W

F0218.ai

When installing the equipment, the selected Type of Protection should be ticked as follows.

- Ex ia IIC T4 Ga
- Ex ic IIC T4 Gc

See the control drawing.

Note 4. Use and setting-up (operation)

If the equipment is mounted in an area where explosive atmospheres may be present, it must be installed in such a way that the risk from electrostatic discharges and propagating brush discharges caused by rapid flow of dust are avoided.

Note 5. Maintenance and repair



A modification of the equipment would no longer comply with the construction described in the certificate documentation.
Only personnel authorized by Yokogawa Electric Corporation can repair the equipment.

Yokogawa Electric Corporation		Model		EJX Series	
Title Control drawing (General)					
No.	IKE045-A91	Page	1	Revision	0
				Date	2020-08-07

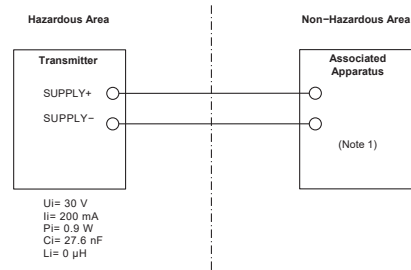

Notes:
1. Associated Apparatus must be a linear power source whose output current is resistively limited.

b. IECEx Intrinsically Safe Ex ic

Caution for IECEx Intrinsically safe Ex ic.

Note 1. EJX/EJA-E series pressure transmitters with optional code /SU21 or /SU22 are applicable for use in hazardous locations

- No. IECEx DEK 13.0061X
- Applicable Standard: IEC 60079-0:2011, IEC 60079-11:2011
- Ex ic IIC T4 Gc
- Ambient Temperature: -30* to 60°C
- * -15 °C when /HE is specified.
- Max. Process Temp.: 120°C
- IP Code: IP66
- Overvoltage Category: I

Note 2. Electrical Data

- Maximum Input Voltage (Ui) = 30 V
- Maximum Internal Capacitance (Ci) = 27.6 nF
- Maximum Internal Inductance (Li) = 0 μH

Note 3. Installation

- The pressure transmitter is allowed to be installed in “nL” systems, on condition that the output parameters of “nL” source (associated energy-limited apparatus) are suitable to the above mentioned input parameters of the pressure transmitter and the cable parameters.

- Cable glands, adapters and/or blanking elements shall be of Ex “n”, Ex “e” or Ex “d” and shall be installed so as to maintain the specified degree of protection of the equipment.
- The instrument modification or parts replacement by other than authorized representative of Yokogawa Electric Corporation is prohibited and will void IECEX certification.

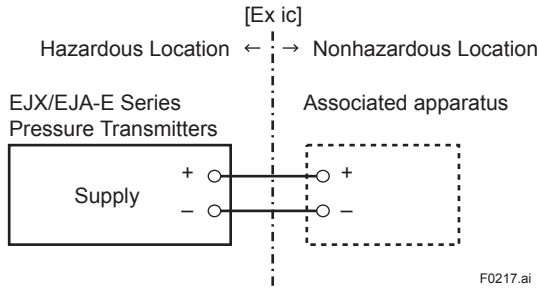

Note 4. Specific Condition of Use



WARNING

- Electrostatic charge may cause an explosion hazard. Avoid any actions that cause the generation of electrostatic charge, such as rubbing with a dry cloth on coating face of the product.
- The apparatus is not capable of dielectric strength tests required by IEC 60079-11. This must be taken into account when installing the apparatus.

c. IECEX Flameproof Type

Caution for IECEX flameproof type.

Note 1. EJX/EJA-E Series pressure transmitters with optional code /SF2 or /SU21 are applicable for use in hazardous locations:

- No. IECEX CSA 07.0008
- Applicable Standard: IEC60079-0:2011, IEC60079-1:2007-4
- Flameproof for Zone 1, Ex d IIC T6...T4 Gb
- Enclosure: IP66/IP67
- Maximum Process Temperature: 120°C (T4), 100°C (T5), 85°C (T6)
- Ambient Temperature: -50 to 75°C (T4), -50 to 80°C (T5), -50 to 75°C (T6)
- Supply Voltage: 42 V dc max. 32 V dc max. (FOUNDATION Fieldbus and PROFIBUS PA type) 9 to 28 V dc, 27 mW (Low Power type)

- Output Signal: 4 to 20 mA dc 15 mA (FOUNDATION Fieldbus and PROFIBUS PA type) 1 to 5 V (Low Power type)

Note 2. Wiring

- In hazardous locations, the cable entry devices shall be of a certified flameproof type, suitable for the conditions of use and correctly installed.
- Unused apertures shall be closed with suitable flameproof certified blanking elements.
- Wiring connection for output signal code Q (Low Power type) shall follow the diagram below.

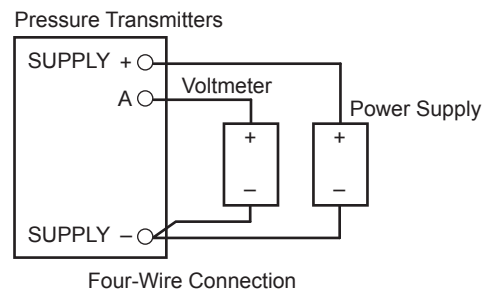
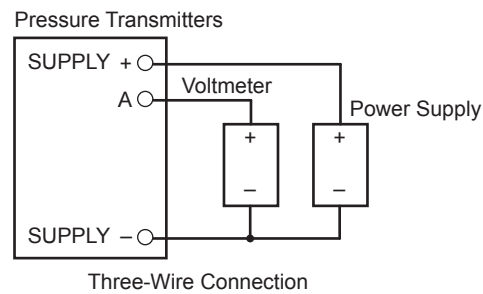

Note 3. Operation

- **WARNING:** AFTER DE-ENERGIZING, DELAY 5 MINUTES BEFORE OPENING.
- **WARNING:** WHEN THE AMBIENT TEMP. ≥ 65°C, USE HEAT-RESISTING CABLE AND CABLE GLAND ≥ 90°C.
- Take care not to generate mechanical sparking when accessing to the instrument and peripheral devices in a hazardous location.
- Electrostatic charge may cause an explosion hazard. Avoid any actions that cause the generation of electrostatic charge, such as rubbing with a dry cloth on coating face of the product.

Note 4. Maintenance and Repair

- The instrument modification or parts replacement by other than authorized representative of Yokogawa Electric Corporation is prohibited and will void IECEx Certification.
- Electrical Connection
A mark indicating the electrical connection type is stamped near the electrical connection port. These marks are as followed.

Screw Size	Marking
ISO M20 × 1.5 female	△ M
ANSI 1/2 NPT female	△ N or △ W

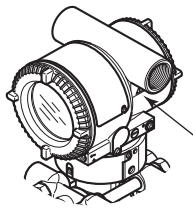

Location of the mark

F0215.ai

d. IECEx Flameproof Type

Caution for IECEx flameproof type.

Note 1. EJX/EJA-E Series pressure transmitters with optional code /SF22 or /SU22* are applicable for use in hazardous locations:

- * /SU22: Except for Fieldbus Communication Type, PROFIBUS PA Type, EJX910A, EJX930A
- No. IECEx DEK 14.0046X
- Applicable Standard: IEC60079-0, IEC60079-1, IEC 60079-31
- Type of Protection and Marking Code:
 - Ex db IIC T6...T4 Gb
 - Ex tb IIIC T85°C Db
- Enclosure: IP66/IP67
- Temperature Class for gas-proof: T6, T5, and T4
- Ambient Temperature for gas-proof: -50 to 75°C (T6), -50 to 80°C (T5), and -50 to 75°C (T4)

- Process Temperature (Tp.) for gas-proof: -50 to 85°C (T6), -50 to 100°C (T5), and -50 to 120°C (T4)
- Maximum Surface Temperature for dust-proof: T85°C (Tamb.: -30* to 75°C, Tp.: -30* to 85°C)
* -15°C when /HE is specified.

Note 2. Electrical Data

- Supply voltage: 42 V dc max. 32 V dc max. (FOUNDATION Fieldbus and PROFIBUS PA type)
9 to 30 V dc, 250 mW (RS485 Modbus Communication Type)
9 to 28 V dc, 27 mW (Low Power type)
- Output signal: 4 to 20 mA, 15 mA (FOUNDATION Fieldbus and PROFIBUS PA type)
RS485 Modbus (RS485 Modbus Communication Type), 1 to 5 Vdc (Low Power type)

Note 3. For combined approval types Once a device of multiple approval type is installed, it should not be re-installed using any other approval types. Apply a permanent mark in the check box of the selected approval type on the certification label on the transmitter to distinguish it from unused approval types.

Note 4. Installation

- All wiring shall comply with local installation requirement.
- In order to prevent the earthing conductor from loosening, the conductor must be secured to the terminal, tightening the screw with appropriate torque. Care must be taken not to twist the conductor.
- Cable glands, adapters and/or blanking elements with a suitable IP rating shall be of Ex d IIC/Ex tb IIIC certified by IECEx and shall be installed so as to maintain the specific degree of protection (IP Code) of the equipment.

- Wiring connection for output signal code Q (Low Power type) shall follow the diagram below.

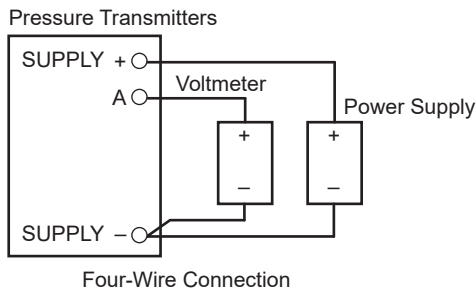
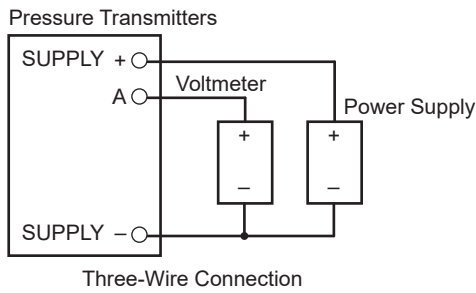

F0219.ai

- Electrical Connection**
A mark indicating the electrical connection type is stamped near the electrical connection port. These marks are as followed.

Screw Size	Marking
ISO M20 × 1.5 female	⚠ M
ANSI 1/2 NPT female	⚠ N or ⚠ W

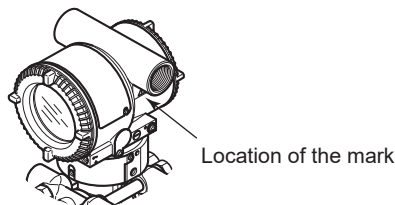

F0220.ai

Note 5. Operation

- Keep the “WARNING” label at the transmitter.
- WARNING:**
- AFTER DE-ENERGIZING, DELAY 5 MINUTES BEFORE OPENING. WHEN THE AMBIENT TEMP. ≥ 65°C, USE HEAT-RESISTING CABLE AND CABLE GLAND ≥ 90°C.
- Take care not to generate mechanical sparking when accessing to the instrument and peripheral devices in a hazardous location.

Note 6. Maintenance and Repair

- WARNING:**
- When maintenance and repair are performed, confirm the following conditions and then perform works. Confirm the power supply is cut off and the voltage of power supply terminal is not supplied.
- Only personnel authorized by Yokogawa Electric Corporation can repair the equipment in accordance with the relevant standards: IEC 60079-19 (Equipment repair, overhaul and reclamation) and IEC 60079-17 (Electrical installation inspection and maintenance); otherwise the certification will be voided.

Note 7. Specific Conditions of Use

- WARNING**
- Electrostatic charge may cause an explosion hazard. Avoid any actions that cause the generation of electrostatic charge, such as rubbing with a dry cloth on coating face of the product.
- The flame paths differ from the standard values in IEC 60079-1. Repair of the equipment is only allowed when done by the manufacturer or an authorized representative.
- The fasteners used to fasten the transmitter enclosure onto the sensor capsule is special fastener, and the property class of it is A2-50 (A4-50) or more.
- For transmitters with a membrane made of titanium, ignition hazard due to impact and friction on the membranes shall be avoided.
- Maximum Surface Temperature for dust-proof: T85°C (Tamb.: -30* to 75°C, Tp.: -30* to 85°C)
* -15°C when /HE is specified.

2.10 EMC Conformity Standards

EN 61326-1 Class A, Table2

EN 61326-2-3

EN 61326-2-5 (for Fieldbus)

Immunity influence during the test

Differential pressure / Pressure: Output shift is specified within $\pm 1\%$ of 1/20 Max span.

Static pressure: Output shift is specified within $\pm 2\%$ of 1 MPa span.

Status Output Line*: Continues to operate without reversal.

*: Only for /AL option.

Condition for EMC test for FOUNDATION fieldbus type: The shield of the cable and the case are connected with a capacitor of 10 nF.



CAUTION

- This instrument is a Class A product, and it is designed for use in the industrial environment.
Please use this instrument in the industrial environment only.
- To meet EMC regulations, Yokogawa recommends that customers run signal wiring through metal conduits or use shielded twisted-pair cabling when installing EJX/EJA-E series transmitters in a plant.

2.11 Pressure Equipment Directive (PED)

(1) General

EJX/EJA-E Series pressure transmitters are categorized as piping under the pressure accessories section of directive 2014/68/EU, which corresponds to Article 4, Paragraph 3 of PED, denoted as Sound Engineering Practice (SEP).

(2) Technical Data

Article 4, Paragraph 3 of PED, denoted as Sound Engineering Practice (SEP).

(3) Operation



CAUTION

- The temperature and pressure of fluid should be maintained at levels that are consistent with normal operating conditions.
- The ambient temperature should be maintained at a level that is consistent with normal operating conditions.
- Please take care to prevent water hammer and the like from inducing excessive pressures in pipes and valves. If phenomena are likely, install a safety valve or take some other appropriate measure to prevent pressure from exceeding PS.
- Take appropriate measures at the device or system level to protect transmitters if they are to be operated near an external heat source.

2.12 EU RoHS Directive

Applicable standard: EN IEC 63000

Applicable production sites are shown below.
The condition of the RoHS compliant production sites are as follows:

Japan, Germany, Saudi Arabia, India, USA

The production sites can be confirmed by the serial number shown in the frame of "NO." in the name plate of the product.

Serial numbers (9 letters): **AA**nnnnnnnn

AA: Identification code of production site

Japan: Use "91" or "90"

USA: Use "U1"

Germany: Use "D1"

Saudi Arabia: Use "Y3"

India: Use "Y1"

2.13 Safety Requirement Standards

Applicable standard: EN 61010-1, C22.2 No.61010-1

(1) Pollution Degree 2

"Pollution degree" describes the degree to which a solid, liquid, or gas which deteriorates dielectric strength or surface resistivity is adhering. "2" applies to normal indoor atmosphere. Normally, only non-conductive pollution occurs. Occasionally, however, temporary conductivity caused by condensation must be expected.

(2) Installation Category I

"Overvoltage category (Installation category)" describes a number which defines a transient overvoltage condition. It implies the regulation for impulse withstand voltage. "I" applies to electrical equipment which is supplied from the circuit when appropriate transient overvoltage control means (interfaces) are provided.

(3) Indoor/Outdoor use

It can be used in indoors and outdoors.

(4) Altitude of installation site

Max. 5,000 m above sea level

3. Component Names

Vertical impulse piping type

Pressure-detector section

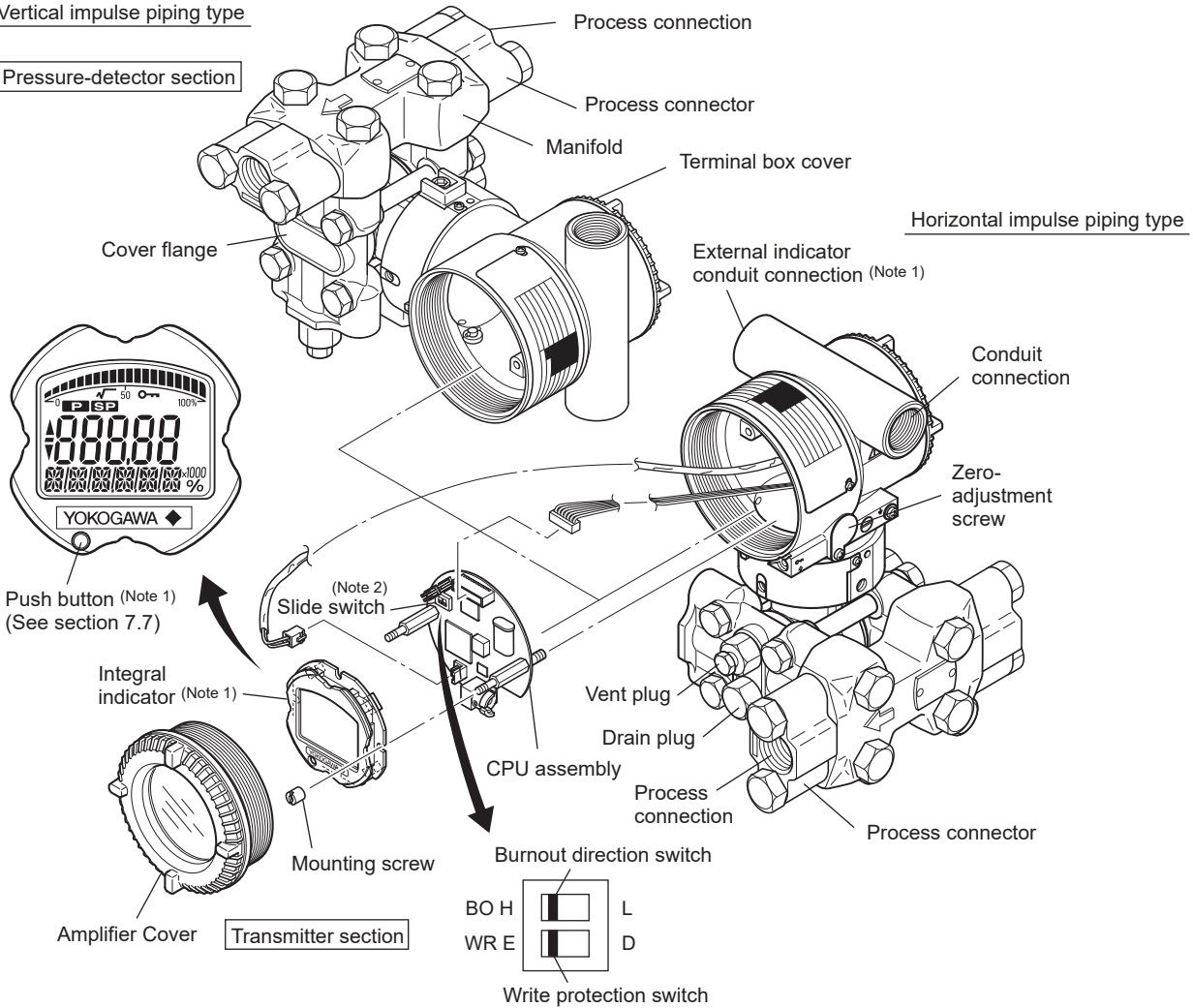

Burnout direction switch (BO)			
Burnout Direction Switch Position	H E		L D
Burnout Direction	HIGH		LOW

Hardware write protection switch (WR)			
Write Protection Switch Position	H E		L D
Write Protection	NO (Write enabled)		YES (Write disabled)

Note 1: See General Specifications sheet of each product for details.

Note 2: Applicable for BRAIN/HART communication type. Set the switches as shown in the figure above to set the burn-out direction and write protection. The Burnout switch is set to the H side for delivery (unless option code /C1 or /C2 is specified in the order), and the hardware write protection switch is set to E side. The setting of the switches can be confirmed via communication. An external zero adjustment screw can only be disabled by communication. To disable the screw, set a parameter before activating the hardware write protect function. The zero adjustment screw is disabled upon shipment when option code /CJ or /CK is specified. See each communication manual.

Figure 3.1 Component Names

Table 3.1 Display Symbol

Display Symbol	Meaning of Display Symbol
√	Display mode is 'square root'. (Display is not lit when 'linear' mode.)
▲	The output signal being zero-adjusted is increasing. Besides, this symbol lights when local parameter setting is in progress.
▼	The output signal being zero-adjusted is decreasing. Besides, this symbol lights when local parameter setting is in progress.
⏏	Write protect function is enabled.

F0302.ai

4. Installation

4.1 Precautions

Before installing the transmitter, read the cautionary notes in section 2.4, "Selecting the Installation Location." For additional informations and limitations according to the selected model, suffix and option codes, please find information in each General Specifications sheet.



IMPORTANT

- When welding piping during construction, take care not to allow welding currents to flow through the transmitter.
- Do not step on this instrument after installation.
- When installing process connectors or a manifold, make sure that no foreign matter has adhered to the seal surface of the gasket before assembling. If foreign matter adheres, it may lead to leaks.

4.2 Mounting

- The transmitter can be mounted on a nominal 2-inch pipe using the mounting bracket supplied, as shown in figure 4.1 and 4.2. The transmitter can be mounted on either a horizontal or a vertical pipe.
- When mounting the bracket on the transmitter, tighten the (four) bolts that hold the transmitter with a torque of approximately 39 N·m {4kgf·m}.
- The transmitter is shipped with the manifold set up as per the order specifications.
- For correct flow measurement, the flow path must always be filled with fluid; otherwise, measurement accuracy cannot be assured.
- For the vertical impulse piping type, it is recommended that the manifold be mounted facing up for liquid flow measurement; facing down for gas flow measurement, as shown in Figure 4.2.

Figure 4.1 and 4.2 shows the mounting of the transmitter for horizontal piping and vertical piping with using the mounting bracket.

Vertical pipe mounting

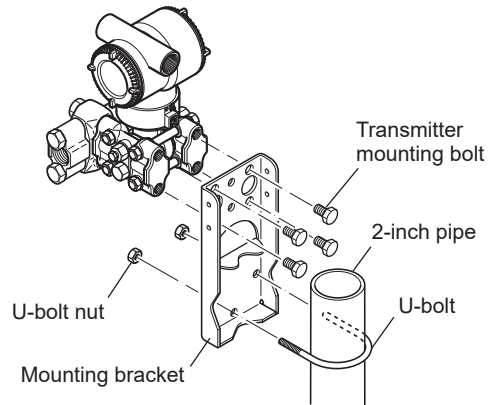

Horizontal pipe mounting

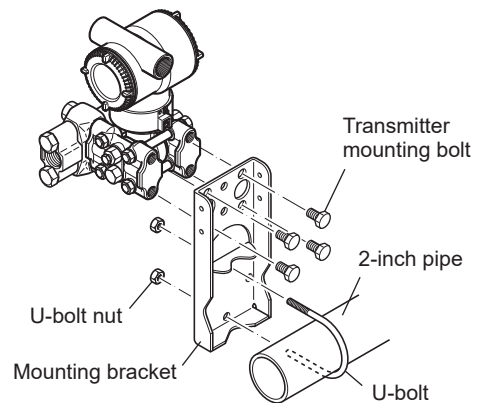

F0401.ai

Figure 4.1 Transmitter Mounting (Horizontal Impulse Piping Type)

Vertical pipe mounting (Process connector upside) Vertical pipe mounting (Process connector downside)

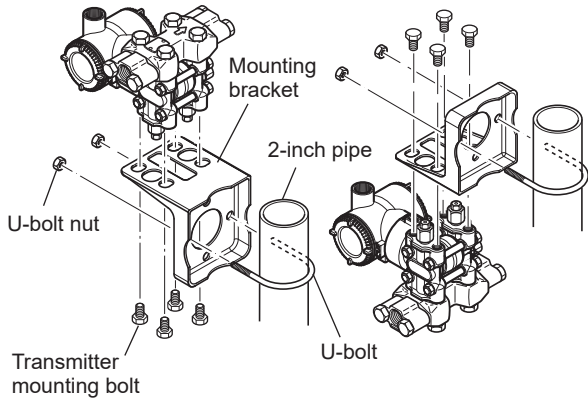

■ In the case of position adjustable bracket

Vertical pipe mounting (Process connector upside) Vertical pipe mounting (Process connector downside)

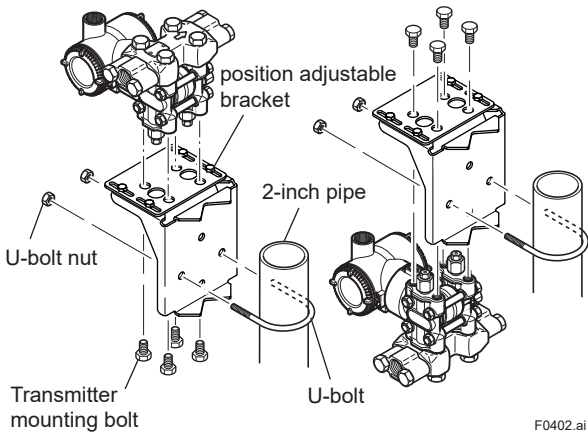

Figure 4.2 Transmitter Mounting (Vertical Impulse Piping Type)

F0402.ai

4.2.1 How to install the position adjustable bracket

The procedures for mounting the transmitter with the position adjustable bracket (L type) are described below. (See figure 4.3)

- (1) Securely fix the transmitter and the position adjustable plate using the transmitter mounting bolts. Tighten the transmitter mounting four bolts with a torque of approximately 39 N·m {4 kgf·m}.
- (2) Attach the bracket to the 2-inch pipe while adjusting the height to the process piping.
- (3) Loosen the position adjustment screw and slide the position adjustable plate on the bracket to align the position of the 2-inch pipe and the process piping.* 1
- (4) Tighten each of the position adjustment four bolts to firmly fix the position adjustable plate and the bracket. After fixing, check that it does not move.

Process connection upside

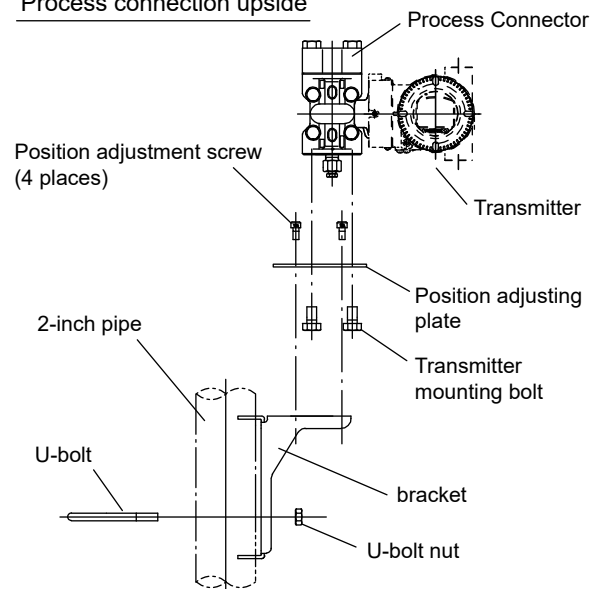

Process connection downside

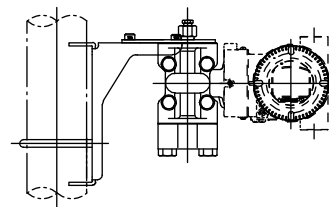

Mount the bracket in the direction as described in the figure.

F0407.ai

Figure 4.3 Mounting with the position adjustable bracket

*1: The position adjustment plate can be adjusted in the range of 75 to 132 mm depending on the mounting direction to the bracket. The adjustment range varies depending on the model and specifications. (See figures 4.4 to 4.5)

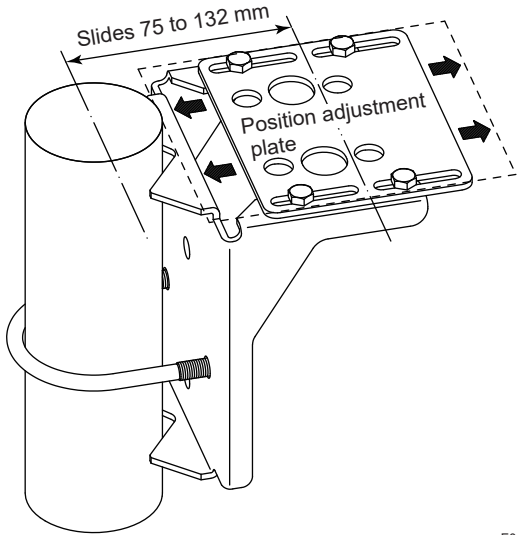

F0408.ai

Figure 4.4 Adjustable range of the plate

	The state of the plate seen from the above	The state of the plate seen from the side (EJX110A)	
Plate in minimum position (75 mm)			
Plate in maximum position (110 mm)			
Inverted plate in maximum position (132 mm)			

↑↓ Inverted

F0409.ai

Figure 4.5 The adjustable range by the mounting direction of the plate

4.3 Changing the manifold assembly

The transmitter is shipped with the manifold assembly specified at the time of ordering. To change the manifold assembly, the drain (vent) plug must be repositioned.

To reposition a drain (vent) plug, use a wrench to slowly and gently unscrew it. Then, remove and remount it on the opposite side. Wrap sealing tape around the drain (vent) plug threads (*1 in the figure below), and apply a lubricant to the threads of the drain (vent) screw(s) (*2 below). To tighten the drain (vent) plugs, apply a torque of 34 to 39 N·m {3.5 to 4 kgf·m}. Manifold bolts are to be tightened uniformly to a torque of 39 to 49 N·m {4 to 5 kgf·m}.

Vertical impulse piping type

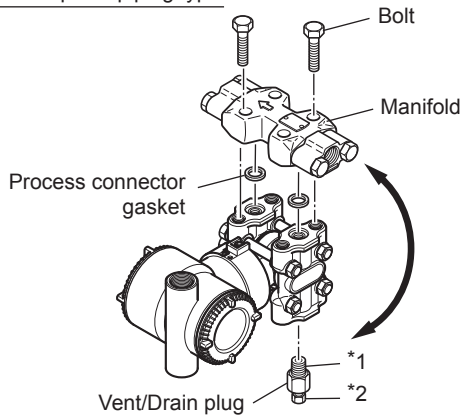

Horizontal impulse piping type

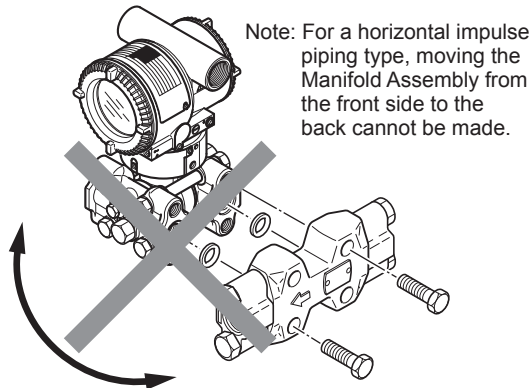

Figure 4.6 Changing Manifold Assembly

F0403.ai

4.4 Swapping the High/Low-pressure Side Connection

This procedure can be applied only to a transmitter with a vertical impulse piping type.

The procedure below can be used to turn the pressure detector assembly 180°. Perform this operation in a maintenance shop with the necessary tools laid out and ready for use, and then install the transmitter in the field after making the change.

- 1) Use an Allen wrench (JIS B4648, nominal 2.5 mm) to remove the two setscrews at the joint between the pressure-detector section and transmitter section.
- 2) Leaving the transmitter section in position, rotate the pressure-detector section 180°.
- 3) Tighten the two setscrews to fix the pressure-detector section and transmitter section together (at a torque of 1.5 N·m).

Reposition the manifold assembly and drain (vent) plugs to the opposite side as described in subsection 4.3.

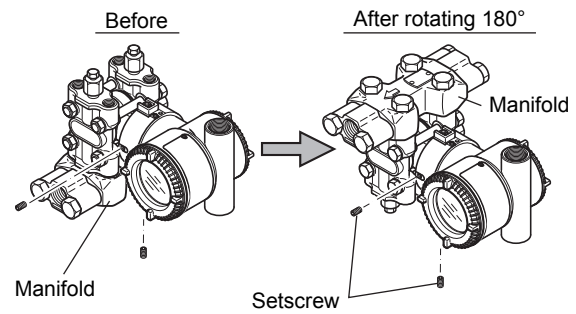

F0404.ai

Figure 4.7 Before and After Modification

4.5 Rotating Transmitter Section

The transmitter section can be rotated approximately 360° and can be fixed at any angle within the above range. (The direction of the rotation is depending on the configuration of the instrument.) Note that there is a stopper which prevents the transmitter section from being rotated more than 360°.

- 1) Remove the two setscrews that fasten the transmitter section and capsule assembly, using the Allen wrench.
- 2) Rotate the transmitter section slowly and stop it at designated position.
- 3) Tighten the two setscrews to a torque of 1.5 N·m.

WARNING

In the case of the explosion-proof/flameproof type transmitter, do not rotate the transmitter part in the hazardous area while the transmitter is energized.

IMPORTANT

Do not rotate the transmitter section more than the above limit.

Vertical impulse piping type

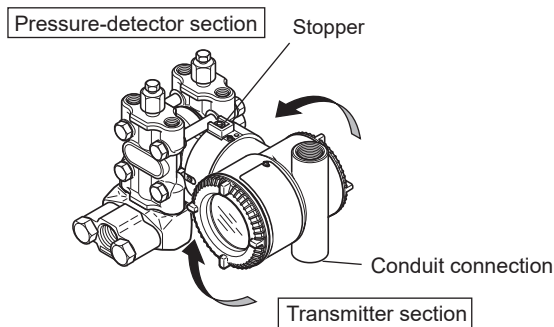

Horizontal impulse piping type

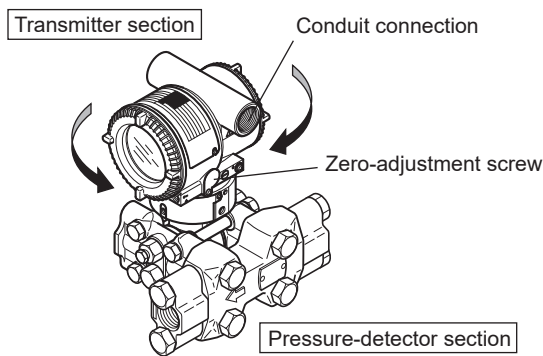

F0405.ai

Figure 4.8 Rotating Transmitter Section (Left Side High Pressure Type)

4.6 Changing the Direction of Integral Indicator

IMPORTANT

Always turn OFF power, release pressure and remove a transmitter to non-hazardous area before disassembling and reassembling an indicator.

An integral indicator can be installed in the following three directions. Follow the instructions in section 8.4 for removing and attaching the integral indicator.

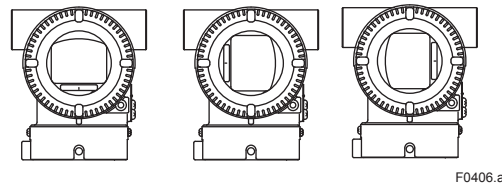

Figure 4.9 Integral Indicator Direction

F0406.ai

5. Installing Impulse Piping

5.1 Process Piping Installation Precautions

The manifold contains a small-bore orifice. For the transmitter of a high pressure connection right side, the orifice is placed facing such a direction as to enable normal flow measurement when fluid is flowed from right to left (as viewed from the front). If the orifice is removed from the manifold, it must be replaced facing the correct direction. (For disassembly and reassembly procedures, see Subsection 8.4.4)

Pay careful attention to the following points when routing the process piping and connection the process piping to the transmitter.

5.1.1 Connecting Process Piping to the Transmitter

(1) Confirming the Process Fluid Flow Direction (Figure 5.1)

The mark “ ← ” on the manifold indicates the direction in which the process fluid is flowed (from right to left). When connecting the process piping to the process connector, confirm the process fluid flow direction.

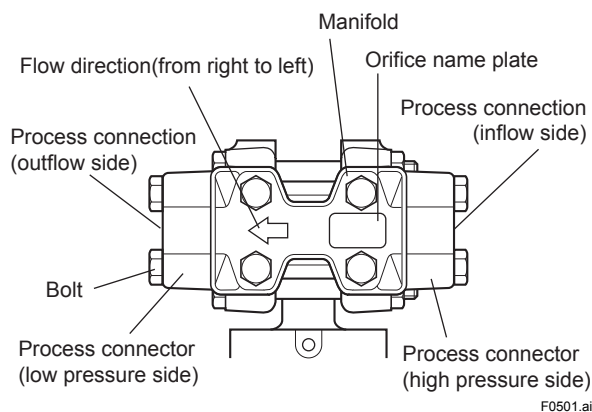

Figure 5.1 Manifold and Flow Direction Indication

(2) Tightening the Process Connector Mounting Bolts

The transmitter is shipped with the process connector mounting bolts only loosely tightened. After connecting the process piping, tighten these bolts uniformly to prevent leaks with a torque of 39 to 49 N·m {4 to 5 kgf·m}.

(3) Removing the Process Connector Port Dustproof Cap

The process connector port threads may be covered with a plastic cap to exclude dust. This cap must be removed before connecting the piping. (Be careful not to damage the threads when removing this cap. Never insert a screwdriver or other tool between the cap and port threads to remove the cap.)

5.1.2 Routing the Process Piping

(1) Relationship between Process Fluid and Manifold Locations (For the vertical impulse piping type)

If condensate (or gas) generated in the process piping were allowed to accumulate, then it would be necessary to remove it periodically by opening the drain (or vent) plug. However, this would generate a transient disturbance in the pressure measurement. Therefore, the process piping must be routed so that any condensate (or gas) generated in the process piping will not accumulate in the pressure-sensing assembly of the transmitter.



NOTE

- If the process fluid is a gas, then as a rule the manifold must be located at the downside of the pressure-sensing assembly. (Figure 5.2)
- If the process fluid is a liquid, then as a rule the manifold must be located at the upside of the pressure-sensing assembly. (Figure 5.3)

(2) Pipe Size for Process Piping

Use a 15 mm (1/2-inch) pipe for process piping connection to the process connector.

(3) Preventing Freezing

If there is any risk that the process fluid in the transmitter pressure-sensing assembly could freeze or solidify, use a steam jacket or heater to maintain the temperature of the fluid.

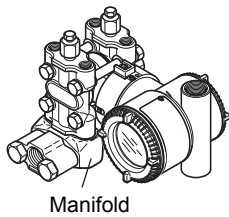

F0502.ai

Figure 5.2 Manifold Location at the Downside (for Gas Flow Measurement)

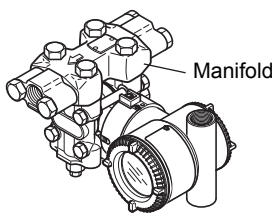

F0503.ai

Figure 5.3 Manifold Location at the Upside (for Liquid Flow Measurement)

5.2 Process Piping Connection Examples

Figure 5.4 shows examples of typical process piping connections. Before connecting the transmitter to the process, study the transmitter installation location, the process piping layout, and the characteristics of the process fluid (corrosiveness, toxicity, flammability, etc.), in order to make appropriate changes and additions to the connection configurations.

Note the following points when referring to these piping examples.

- The high pressure connecting port on the transmitter is shown on the right (as viewed from the front).
- The transmitter process piping connection is shown for a vertical impulse piping configuration in which the direction of process flow is from right to left.
- The process piping material used must be compatible with the process pressure, temperature, and other conditions.

- A variety of process piping-mounted stop valves are available according to the type of connection (flanged, screwed, welded), construction (globe, gate, or ball valve), temperature and pressure. Select the type of valve most appropriate for the application.

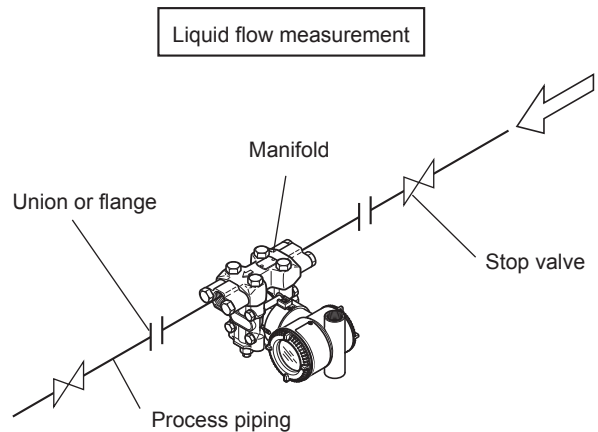
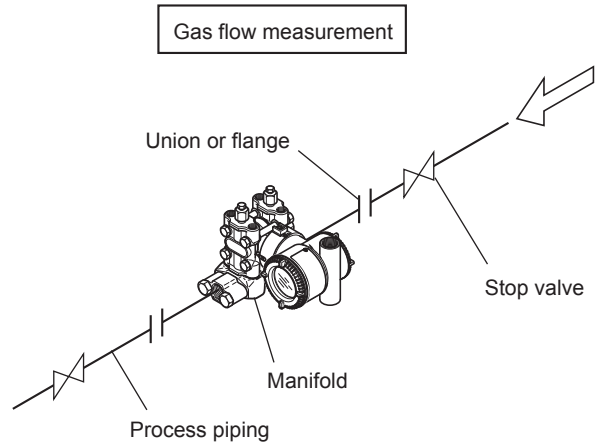

F0504.ai

Figure 5.4 Process Piping Connection Examples

6. Wiring

6.1 Wiring Precautions



IMPORTANT

- Lay wiring as far as possible from electrical noise sources such as large capacity transformers, motors, and power supplies.
- Remove the electrical connection dust cap (plug) before wiring.
- All threaded parts must be treated with waterproofing sealant. (A non-hardening sealant is recommended.)
- To prevent noise pickup, do not pass signal and power cables through the same ducts.
- Explosion-protected instruments must be wired in accordance with specific requirements (and, in certain countries, legal regulations) in order to preserve the effectiveness of their explosion-protected features.
- The terminal box cover is locked by an Allen head bolt (a shrouding bolt) on ATEX flameproof type transmitters. When the shrouding bolt is driven clockwise using an Allen wrench, it goes in. The cover lock can then be released and the cover can be opened by hand. See subsection 8.4 “Disassembly and Reassembly” for details.
- Plug and seal an unused conduit connection.

6.2 Selecting the Wiring Materials

- Use stranded leadwires or cables which are the same as or better than 600 V grade PVC insulated wire (JIS C3307) or its equivalent.
- Use shielded wires in areas that are susceptible to electrical noise.
- In areas with higher or lower ambient temperatures, use appropriate wires or cables.
- In environment where oils, solvents, corrosive gases or liquids may be present, use wires or cables that are resistant to such substances.
- It is recommended that crimp-on solderless terminal lugs (for 4 mm screws) with insulating sleeves be used for leadwire ends.

6.3 Connections of External Wiring to Terminal Box

• Terminal Configuration

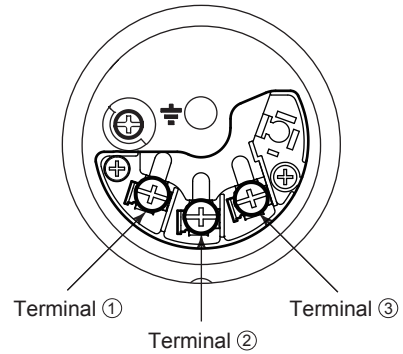

F0613.ai

• Terminal Wiring for 4 to 20 mA output, FOUNDATION Fieldbus type, and PROFIBUS PA type.

SUPPLY	+	①] Power supply and output terminals
	-	②	
CHECK	+	③] External indicator (ammeter) terminals*1,2
or	-	②	
ALARM	+	③] Status contact output terminals ²
	-	②	
			⊥ Ground terminal

*1: When using an external indicator or check meter, the internal resistance must be 10 Ω or less. A check meter or indicator cannot be connected when /AL option is specified.

*2: Not available for FOUNDATION Fieldbus and PROFIBUS PA communication types.

• Terminal Wiring for 1 to 5 V output

SUPPLY	+	①] Power supply terminals
	-	②	
VOUT	+	③] 1 to 5 V DC with HART communication terminals
	-	②	
			⊥ Ground terminal

F0614.ai

Figure 6.1 Terminal

6.3.1 Power Supply Wiring Connection



IMPORTANT

Connecting with the commercial AC power supply will damage the device. Be sure to use the DC power supply in the predetermined range.

Connect the power supply wiring to the SUPPLY + and – terminals. When /AL is specified, also refer to subsection 6.3.5.

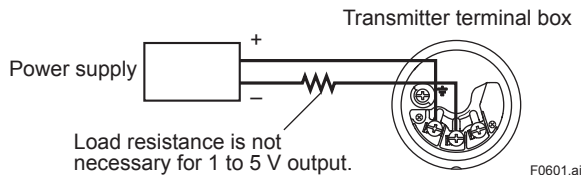

Figure 6.2 Power Supply Wiring Connection

6.3.2 External Indicator Connection

Available only for 4 to 20mA output type and when /AL is not specified.

Connect wiring for external indicators to the CHECK (+) and SUPPLY – terminals.

(Note) Use a external indicator whose internal resistance is 10 Ω or less.

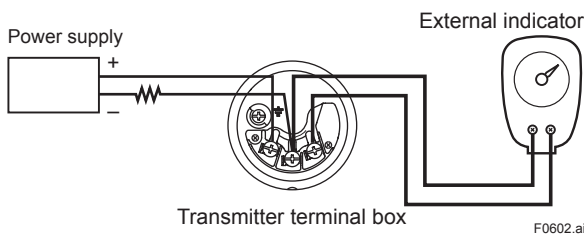

Figure 6.3 External Indicator Connection

6.3.3 Communicator Connection

- 4 to 20 mA output, BRAIN / HART



IMPORTANT

Analog output may change temporarily in connecting with BRAIN terminal due to an initial current flowed to it. To prevent communication signal affecting the upper system, it is recommended to install a low-pass filter (approximately 0.1s)

Connect the BT200 or HART Communicator to the SUPPLY + and – terminals. (Use hooks.)

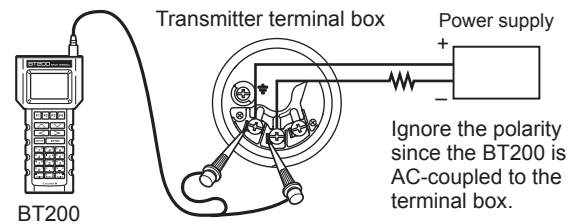

Figure 6.4 BT200 Connection

- 1 to 5 V output, HART
Connect the HART communicator or configuration tool to the SUPPLY - and VOUT (+) terminals. (Use hooks.)

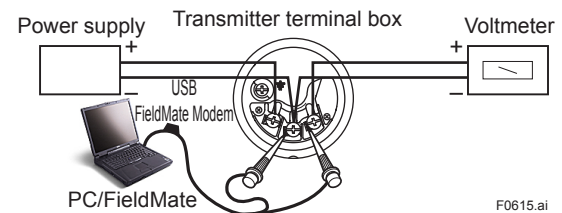

Figure 6.5 Four wire connection

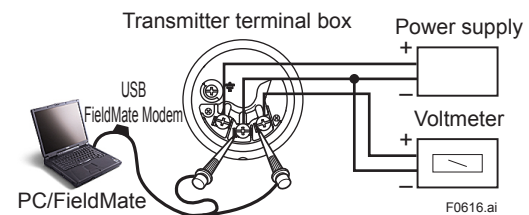

Figure 6.6 Three wire connection

6.3.4 Check Meter Connection

Available only for 4 to 20mA output type and when /AL is not specified.

Connect the check meter to the CHECK (+) and SUPPLY – terminals. (Use hooks.)

- A 4 to 20 mA DC output signal from the CHECK A (+) and SUPPLY – terminals.

(Note) Use a check meter whose internal resistance is 10 Ω or less.

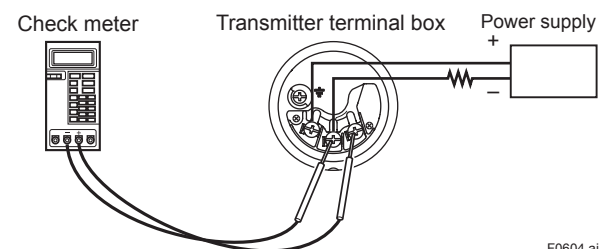

Figure 6.7 Check Meter Connection

6.3.5 Status Output Connection

When option code /AL is specified, connect the external wiring as shown in Figure 6.5.

To configure and activate the process alarm function and status output, it is necessary to set some parameters. Refer to each communication manual for procedures.

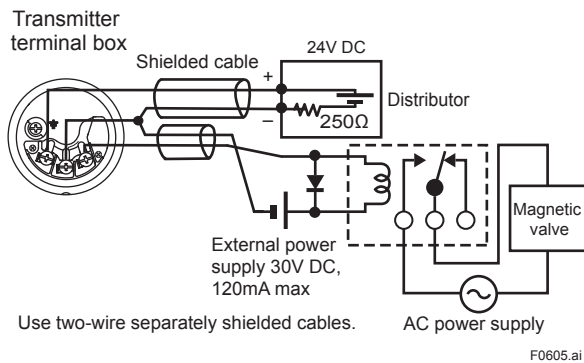

Figure 6.8 Status Output Connection

6.4 Wiring

6.4.1 Loop Configuration

Since the DPharp uses a two-wire transmission system for 4 to 20 mA output, signal wiring is also used as power wiring.

DC power is required for the transmitter loop. The transmitter and distributor are connected as shown below.

For details of the power supply voltage and load resistance, see section 6.6.

For 1 to 5 V output, three or four wire system is used. See (3).

(1) 4 to 20 mA output, General-use Type and Flameproof Type

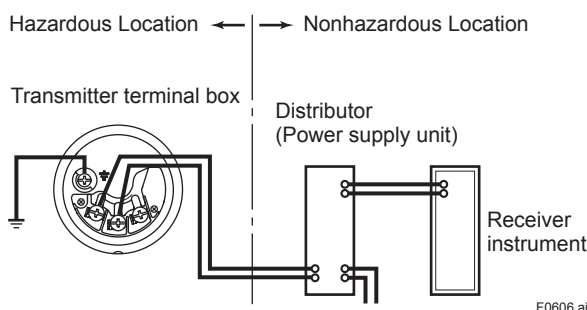

Figure 6.9 Connection between Transmitter and Distributor

(2) 4 to 20 mA output, Intrinsically Safe Type

With the intrinsically safe type, a safety barrier must be included in the loop.

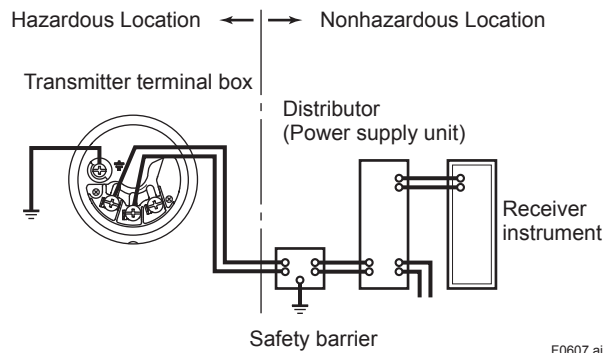

Figure 6.10 Connection between Transmitter and Distributor

(3) 1 to 5 V output

Either three or four wire system is used.

Power supply line and 1 to 5 V signal line commonly use the SUPPLY - terminal.



NOTE

With three wire connection, the cable length may affect the measurement accuracy of the output signal.

In either three-wire or four-wire connection, recommended wiring distance is 200 m or less, and the use of shielded cable is recommended.

■ Three wire connection

For three wire system, a negative wiring shall be commonly used for power supply and signal line.

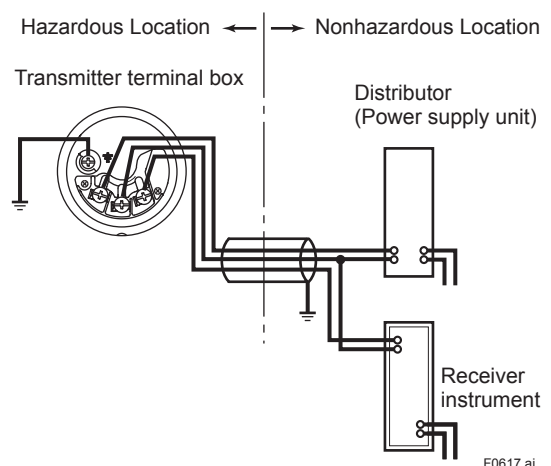

Figure 6.11 Connection between Transmitter, Distributer and Receiver

- Four wire connection
Fasten the negative side wiring of both power supply and signal line to the SUPPLY - terminal.

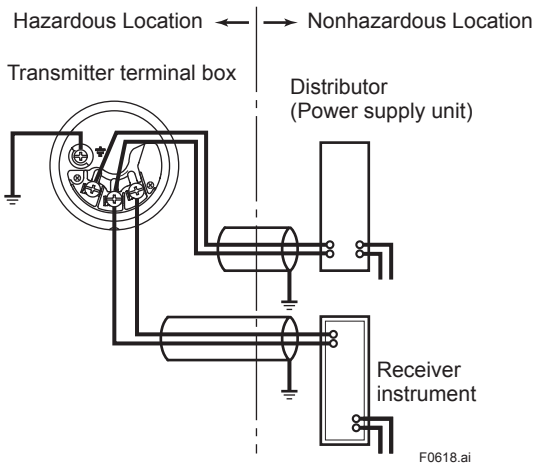

Figure 6.12 Connection between Transmitter, Distributer and Receiver

6.4.2 Wiring Installation

(1) General-use Type and Intrinsically Safe Type

With the cable wiring, use a metallic conduit or waterproof glands.

- Apply a non-hardening sealant to the terminal box connection port and to the threads on the flexible metal conduit for waterproofing.

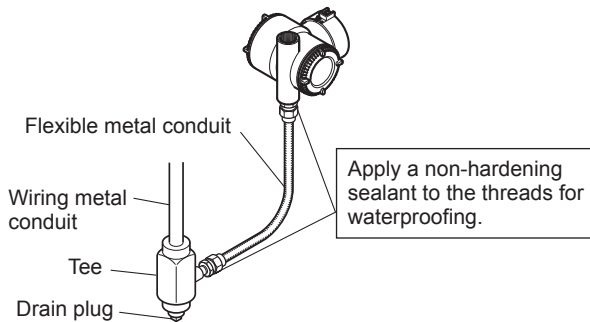

Figure 6.13 Typical Wiring Using Flexible Metal Conduit

(2) Flameproof Type

Wire cables through a flameproof packing adapter, or use a flameproof metal conduit.

- Wiring cable through flameproof packing adapter.

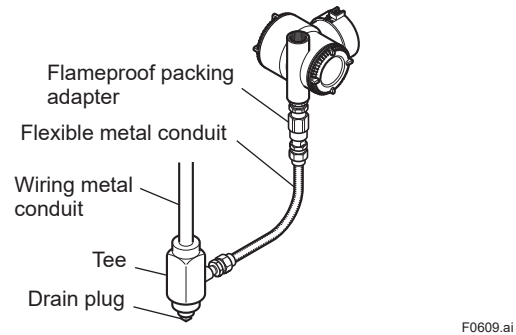

Figure 6.14 Typical Cable Wiring Using Flameproof Packing Adapter

- Flameproof metal conduit wiring

- A seal fitting must be installed near the terminal box connection port for a sealed construction.
- Apply a non-hardening sealant to the threads of the terminal box connection port, flexible metal conduit and seal fitting for waterproofing.

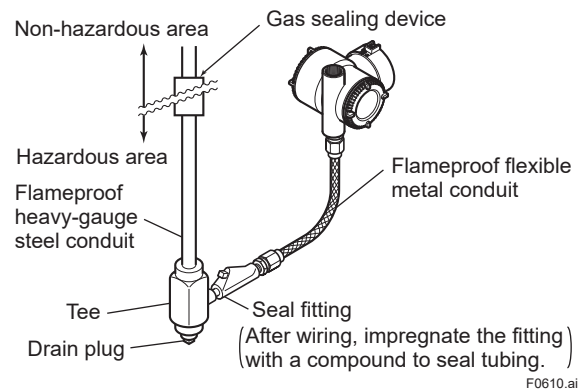

Figure 6.15 Typical Wiring Using Flameproof Metal Conduit



IMPORTANT

When electrical connection code “7” or “C” is specified, the blanking element at the electrical connection port is provided with sealing tape applied. As using sealing tape is prohibited in the hazardous area Group IIC by the requirements of IEC 60079-14, remove the sealing tape and apply appropriate seal to the blanking element in accordance with IEC 60079-14, if the instrument is used in conjunction with gases allocated to Group IIC.

6.5 Grounding

Grounding is always required for the proper operation of transmitters. Follow the domestic electrical requirements as regulated in each country. For a transmitter with a built-in lightning protector, grounding should satisfy ground resistance of 10Ω or less.

Ground terminals are located on the inside and outside of the terminal box. Either of these terminals may be used.

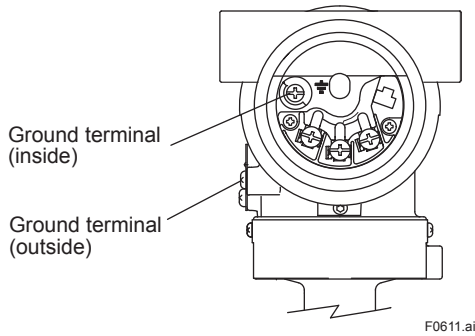

Figure 6.16 Ground Terminals

6.6 Power Supply Voltage and Load Resistance

For 4 to 20 mA output only.

When configuring the loop, make sure that the external load resistance is within the range in the figure below.

(Note) In case of an intrinsically safe transmitter, external load resistance includes safety barrier resistance.

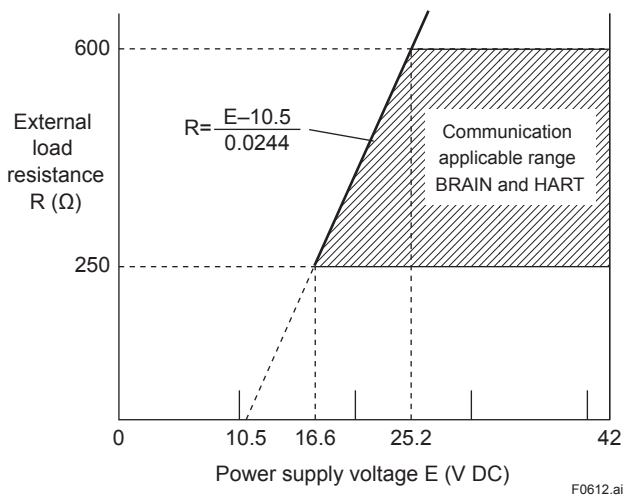

Figure 6.17 Relationship between Power Supply Voltage and External Load Resistance

7. Operation

7.1 Preparation for Starting Operation

The Model EJ□115□ low flow transmitter measures the flow rates of liquids and gases. This section describes the operation procedure for the EJ□115□ as shown in Figure 7.1 (vertical impulse piping type, high-pressure connection: right side) when measuring a liquid flow rate.

- (a) Follow the procedures below to introduce process pressure into the transmitter.
 - 1) Open the stop valve on the downstream side.
 - 2) Gradually open the stop valve on the upstream side to introduce process fluid into the transmitter pressure-detector section. This will cause process fluid to flow into the orifice built in the manifold, and apply flow-dependent differential pressure to the high and low pressure sides of the transmitter.
 - 3) Confirm that there are no pressure leaks in the stop valves on the upstream and downstream sides, process piping connection or transmitter, etc.
- (b) Venting Gas from the Transmitter Pressure-detector Section.

Since the piping in the example of Figure 7.1 is constructed to be self-venting, no venting operation is required. If it is not possible to make the piping self-venting, refer to Subsection 7.6 for instructions.
- (c) Turn ON power and connect the BT200.

Open the terminal box cover, and connect the BT200 to the SUPPLY + and – terminals.
- (d) Using the BT200, confirm that the transmitter is operating properly. Check parameter values or change the setpoints as necessary.

If the transmitter is equipped with an integral indicator, its indication can be used to confirm that the transmitter is operating properly.

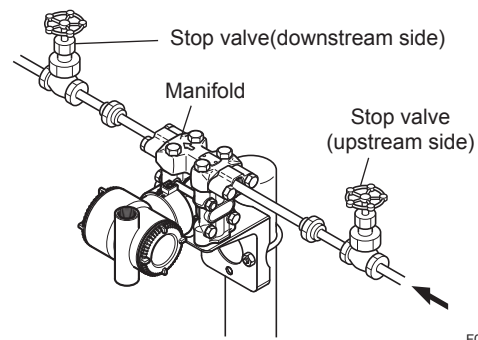

Figure 7.1 Liquid Flow Measurement

F0701.ai

■ **Confirming that Transmitter is Operating Properly**

Using the BT200



IMPORTANT

- Analog output may change temporally in connecting with BRAIN terminal due to an initial current flowed to it. To prevent communication signal affecting the upper system, it is recommended to install a low-pass filter (approximately 0.1s).
- Communication signal is superimposed on analog output signal. It is recommended to set a low-pass filter (approximately 0.1s) to the receiver in order to reduce the output effect from communication signal. Before online-communication, confirm that communication signal does not give effect on the upper system.

- If the wiring system is faulty, 'communication error' appears on the display.
- If the transmitter is faulty, 'SELF CHECK ERROR' appears on the display.

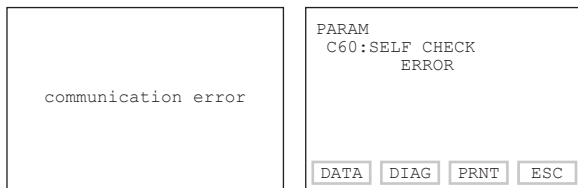

Communication error (Faulty wiring)

Self-diagnostic error (Faulty transmitter)

F0702.ai

Figure 7.2 BT200 Display

Using the integral indicator

- If the wiring system is faulty, the display stays blank.
- If the transmitter is faulty, an error code is displayed.

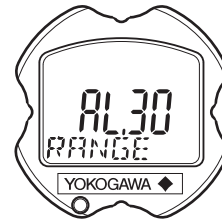

Self-diagnostic error on the integral indicator (Faulty transmitter)

F0703.ai

Figure 7.3 Integral Indicator with Error Code



NOTE

If any of the above errors are indicated on the display of the integral indicator or the communicator, refer to subsection 8.5.3 for the corrective action.

■ **Verify and Change Transmitter Parameter Setting and Values**

The parameters related to the following items are set at factory as specified in order.

- Calibration range
- Integral indicator display
- Output mode
- Software damping (optional)

Other parameters like following are shipped with the default setting.

- Low-cut
- Process alarm setting
- Static pressure range
- Signal characterizer
- Write protection

To confirm or change the values, see IM 01C25T01-06EN or 01C25T03-01E.

7.2 Zero Point Adjustment

After completing preparations for operating the transmitter, adjust the zero point.

Zero point adjustment can be done by turning the transmitter's zero-adjustment screw or by using the communicator. This section describes the procedure for the zero-adjustment screw. For the communicator procedure, see the communication manual.



IMPORTANT

- Do not turn off the power to the transmitter immediately after performing a zero point adjustment. Powering off within 30 seconds of performing this procedure will return the zero point to its previous setting.
- Using zero-point screw requires the parameter EXT_ZERO_ADJUSTMENT is set to "Enabled." When option code /CJ or /CK is specified, the parameter is set to disabled upon shipment. Refer to each communication manual for confirming or changing the setting.



NOTE

Before performing this adjustment, make sure that the external zero adjustment function has NOT been disabled by a parameter setting.



NOTE

Because the output value may be affected by the transmitter's mounting position, zero adjustment should be executed after installing the transmitter. If you have to adjust zero point before installation, make the posture of the transmitter close to the actual installation state when adjusting zero.

To check the output signal, use a digital multimeter, calibrator, or communicator.

■ Adjusting Zero Point for Differential Pressure Transmitters

Before adjusting zero point, make sure that the equalizing valve is open.

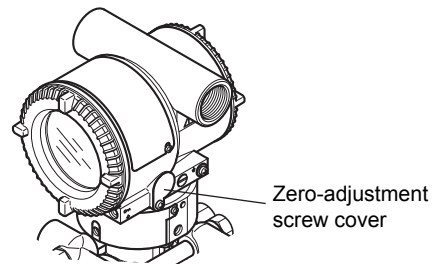

F0704.ai

Figure 7.4 External Zero Adjustment Screw

The zero-adjustment screw is located inside the cover.

Use a slotted screwdriver to turn the zero-adjustment screw. Equalize the transmitter, then turn the screw clockwise to increase the output or counterclockwise to decrease the output. The zero point adjustment can be made with a resolution of 0.01% of the setting range. The degree of zero adjustments varies with the screw turning speed; turn the screw slowly to make a fine adjustment, quickly to make a rough adjustment.

7.3 Starting Operation

After completing the zero point adjustment, follow the procedure below to start operation.

- 1) Open the stop valve on the upstream side.
- 2) Gradually open the stop valve on the downstream side. This places the transmitter in an operational condition.
- 3) Confirm the operating status. If the output signal exhibits wide fluctuations (hunting) due to periodic variation in the process pressure, use BT200 to dampen the transmitter output signal. Confirm the hunting using a receiving instrument or the integral indicator, and set the optimum damping time constant.
- 4) After confirming the operating status, perform the following.



IMPORTANT

- Remove the BT200 from the terminal box, and confirm that none of the terminal screws are loose.
- Close the terminal box cover and the amplifier cover. Screw each cover in tightly until it will not turn further.
- There are two covers that must be locked on the ATEX Flameproof type transmitters. An Allen head bolts (shrouding bolts) are provided under edge of the each cover for locking. When a shrouding bolts are driven counterclockwise by an Allen wrench, it is coming out and locks up a cover. (See section 8.4) After locking, the covers should be confirmed not to be opened.
- Tighten the zero-adjustment cover mounting screw to fix the cover in position.

7.4 Shutting Down Operation

Shut down the transmitter operation as follows.

- 1) Turn off the power.
- 2) Close the stop valves on the up and downstream sides.



NOTE

Whenever shutting down the transmitter for a long period, remove any process fluid from the transmitter pressure-detector section.

7.5 Transmitter Measurement Range (Determining Differential Pressure Range)

The following describes the procedure for calculating the differential pressure range and the calculation example in low flow measurement.

Conversion factor in pressure unit:

- 1 Pa = 1.01972×10⁻¹ mmH₂O
- 1 mmH₂O = 9.80665 Pa
- 1 atm = 1.01325×10² kPa

7.5.1 Determining the Differential Pressure Range

Use the following procedures to determine a differential pressure range according to the fluid conditions being measured.

- (a) Calculate a water or air equivalent flow from the flow of the fluid being measured (100% flow).

■ Equivalent Water Flow Calculation

$$Q_w = 0.03162 \cdot Q_f \cdot \sqrt{pf} \dots\dots\dots (1)$$

- Where, Q_w: Water equivalent volumetric flow (m³/h) at 4°C, 1 atm
- Q_f: Volumetric liquid flow (m³/h) at operating conditions (t°C, p kPa)
- pf: Specific liquid density (kg/m³) at operating conditions (t°C, p kPa)

■ Equivalent Air Flow Calculation

$$Q_o = 0.5356 \cdot Q_n \sqrt{\frac{\rho_n}{p_n} \cdot \frac{273.15 + t}{101.325 + p} \cdot \frac{Z_f}{Z_n}} \dots\dots\dots (2)$$

- Where, Q_o: Air equivalent volumetric flow at 0°C, 1 atm (Nm³/h)
- Q_n: Volumetric gas flow at 0°C, 1 atm (Nm³/h)
- p_n: Specific gas density at 0°C, 1 atm (kg/Nm³)
- Z_n: Compression factor of gas at 0°C, 1 atm
- Z_f: Compression factor of gas at operations conditions (t°C, p kPa)

- (b) Obtain a differential pressure from the above equivalent water or air flow using the nomograph shown in Figure 7.5.1 or 7.5.2. In this procedure, multiply Q_w or Q_o by 1000/60 to convert the flow unit into liter/min.
- (c) Select an orifice bore, taking into considerations pressure loss, etc.
- (d) As necessary, calculate Reynolds number at normal flow rate and correct the differential pressure obtained from the procedure (b).

■ Reynolds Number Calculation

$$Re = 354 \frac{W}{D \cdot \mu} \dots\dots\dots (3)$$

- Where, Re: Reynolds number at normal flow rate
- W: Weight flow at normal flow rate (kg/h) (Note)
- D: Orifice bore (mm)
- μ: Viscosity (mPa·s)

Note: Determination of W
 · For liquid, W=Q_f·pf
 · For gas, W=Q_n·p_n

■ Differential Pressure Correction using Reynolds Number

$$\Delta P = \left(\frac{1}{K_{af}/K_a} \right)^2 \cdot \Delta P_0$$

- Where, ΔP: Corrected differential pressure
- ΔP₀: Differential pressure obtained from procedure (b)
- K_{af}/k_a: Correction factor obtained from Figure 7.5.3

For details concerning determination of differential pressure correction using Reynolds number, pressure loss, etc., refer to TI 01C20K00-01E.

7.5.2 Example of Calculation

Fluid:	N ₂ gas (Nitrogen gas)
Flow range:	0 to 25 Nm ³ /h (flow rate at 0°C, 1 atm)
Normal flow rate:	18 Nm ³ /h
Specific density:	1.251 kg/Nm ³ (specific density at 0°C, 1 atm)
Temperature:	30°C
Pressure:	100 kPa
Viscosity:	0.018 mPa·s

From Equation (2), air equivalent volumetric flow Q_o is:

$$Q_o = 0.5356 \times 25 \sqrt{1.251 \times \frac{273.15 + 30}{101.325 + 100}}$$

$$= 18.38 \text{ Nm}^3/\text{h} = 306.3 \text{ NI}/\text{min}$$

A differential pressure range of 0 to 2400 mmH₂O is obtained from Figure 7.5.2 applying an orifice bore of 6.350 mm (where, Z_f/Z_n=1 is assumed).

From Equation (3), Reynolds number at normal flow rate Re is:

$$Re = 354 \times \frac{18 \times 1.251}{6.35 \times 0.018} = 6.97 \times 10^4$$

Since the correction factor (1.00) is constant at this Reynolds number, no differential pressure correction is required. Consequently, the differential pressure range is determined as 0 to 2400 mmH₂O.

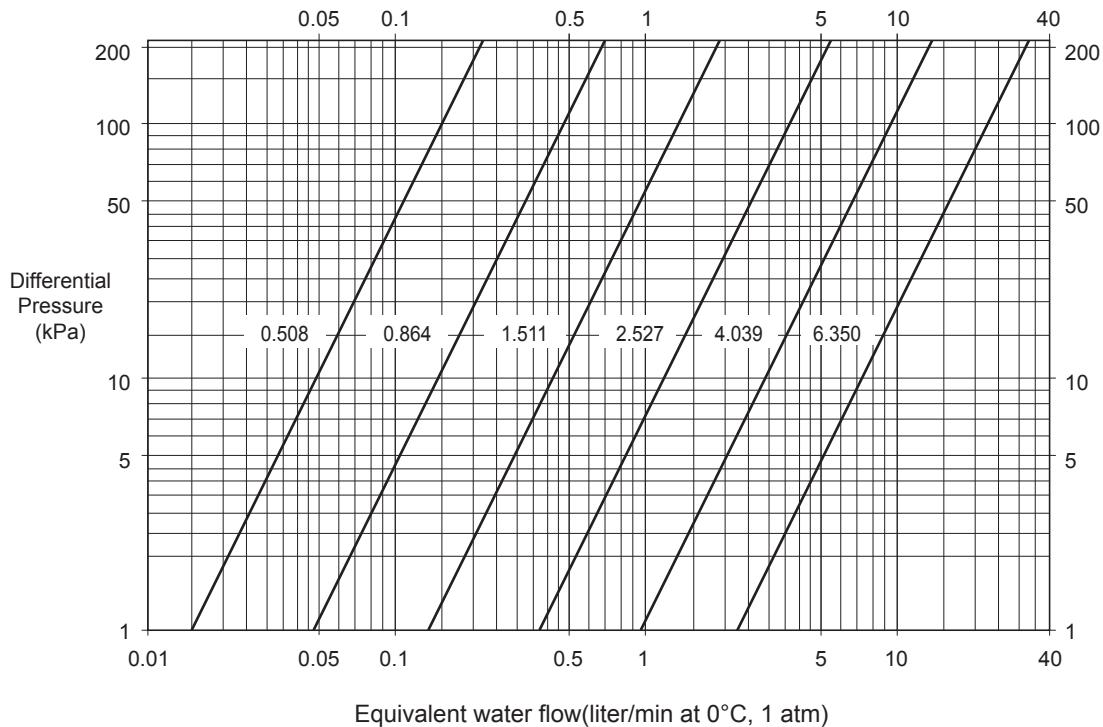

F0705.ai

Figure 7.5.1 Relationship between Equivalent Water Flow and Differential Pressure

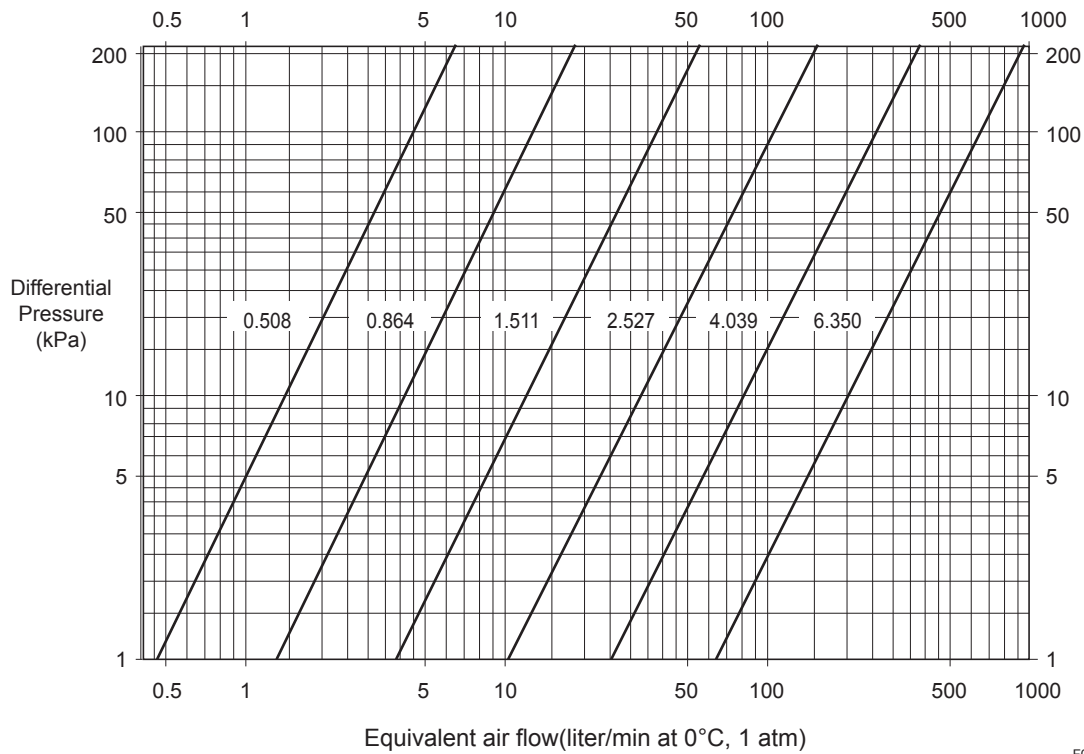

F0706.ai

Figure 7.5.2 Relationship between Equivalent Air Flow and Differential Pressure

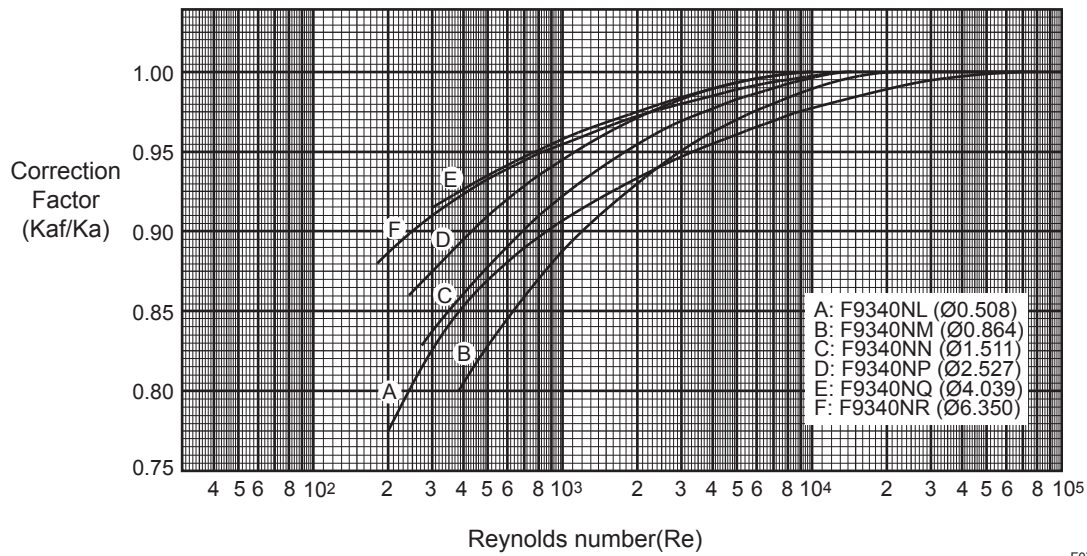

F0707.ai

Figure 7.5.3 Relationship between Reynolds Number and Correction Factor

7.6 Venting or Draining Transmitter Pressure-detector Section

Since this transmitter is designed to be self-draining and self-venting with vertical impulse piping connections, neither draining nor venting will be required if the impulse piping is configured appropriately for self-draining or self-venting operation.

If condensate (or gas) collects in the transmitter pressure-detector section, the measured pressure may be in error. If it is not possible to configure the piping for self-draining (or self-venting) operation, you will need to loosen the drain (vent) screw on the transmitter to completely drain (vent) any stagnated liquid (gas).

However, since draining condensate or bleeding off gas gives the pressure measurement disturbance, this should not be done when the loop is in operation.

WARNING

Since the accumulated liquid (or gas) may be toxic or otherwise harmful, take appropriate care to avoid contact with the body, or inhalation of vapors.

7.6.1 Draining Condensate

- 1) Gradually open the drain screw or drain plug and drain the transmitter pressure-detector section. (See Figure 7.6.1.)
- 2) When all accumulated liquid is completely removed, close the drain screw or drain plug.
- 3) Tighten the drain screw to a torque of 10 N·m {1kgf·m}, and the drain plug to a torque of 34 to 39 N·m {3.5 to 4 kgf·m}.

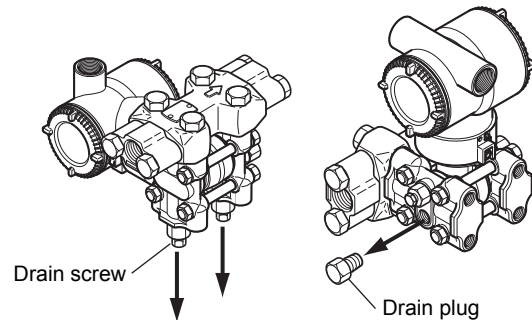

When you loosen the drain screw or drain plug, the accumulated liquid will be expelled in the direction of the arrow.

F0708.ai

Figure 7.6.1 Draining the Transmitter

7.6.2 Venting Gas

- 1) Gradually open the vent screw to vent gas from the transmitter pressure-detector section. (See Figure 7.6.2.)
- 2) When the transmitter is completely vented, close the vent screw.
- 3) Tighten the vent screw to a torque of 10 N·m {1kgf·m}.

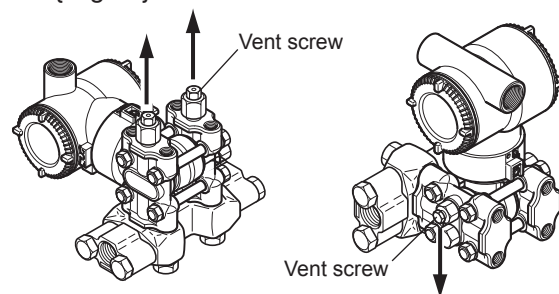

When you loosen the vent screw, the gas escapes in the direction of the arrow.

F0709.ai

Figure 7.6.2 Venting the Transmitter

7.7 Local Parameter Setting



WARNING

The local push button on the integral indicator must not be used in a hazardous area. When it is necessary to use the push button, operate it in a non-hazardous location. In the case of the explosion-proof/flameproof type transmitter, please refer to section 2.9 for each product.



IMPORTANT

- Do not turn off the power to the transmitter immediately after performing parameter setting. Powering off within 30 seconds of performing this procedure will return the parameter to its previous setting.
- The parameter 'Ext SW(HART)' or 'J55:EXT ZERO ADJ (BRAIN)' must be "Enabled" to perform this configuration. When option code /CJ or /CK is specified, the parameter is set to disabled upon shipment. Please refer to either IM 01C25T01-06EN for the HART communication type, or IM 01C25T03-01E for the BRAIN communication type for the setting procedure.
- The Local Parameter Setting function is available with HART or BRAIN communication type.
LCD update will be slower at low ambient temperature, and it is recommended to use LPS function at temperatures above -10 degrees C.

7.7.1 Local Parameter Setting (LPS) Overview

Parameter configuration by the zero-adjustment screw and push button (integral indicator code E) offers easy and quick setup for parameters of Loop test, Tag number, Unit, LRV, URV, Damping, Output mode (linear/square root), Display out 1, and Re-range by applying actual pressure (LRV/URV) and Device Information. There is no effect on measurement signal (analog output or communication signal) when Local Parameter Setting is carried out.

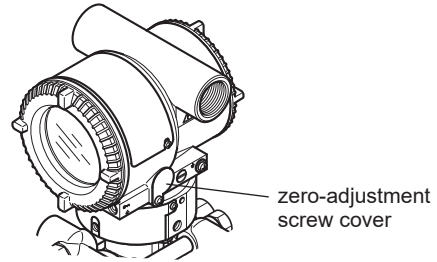

F0710.ai

Figure 7.7 Zero-adjustment Screw

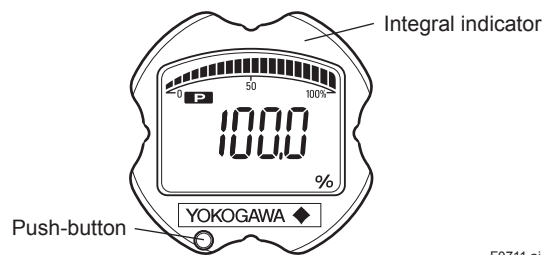

F0711.ai

Figure 7.8 Range-Setting Switch (push button)

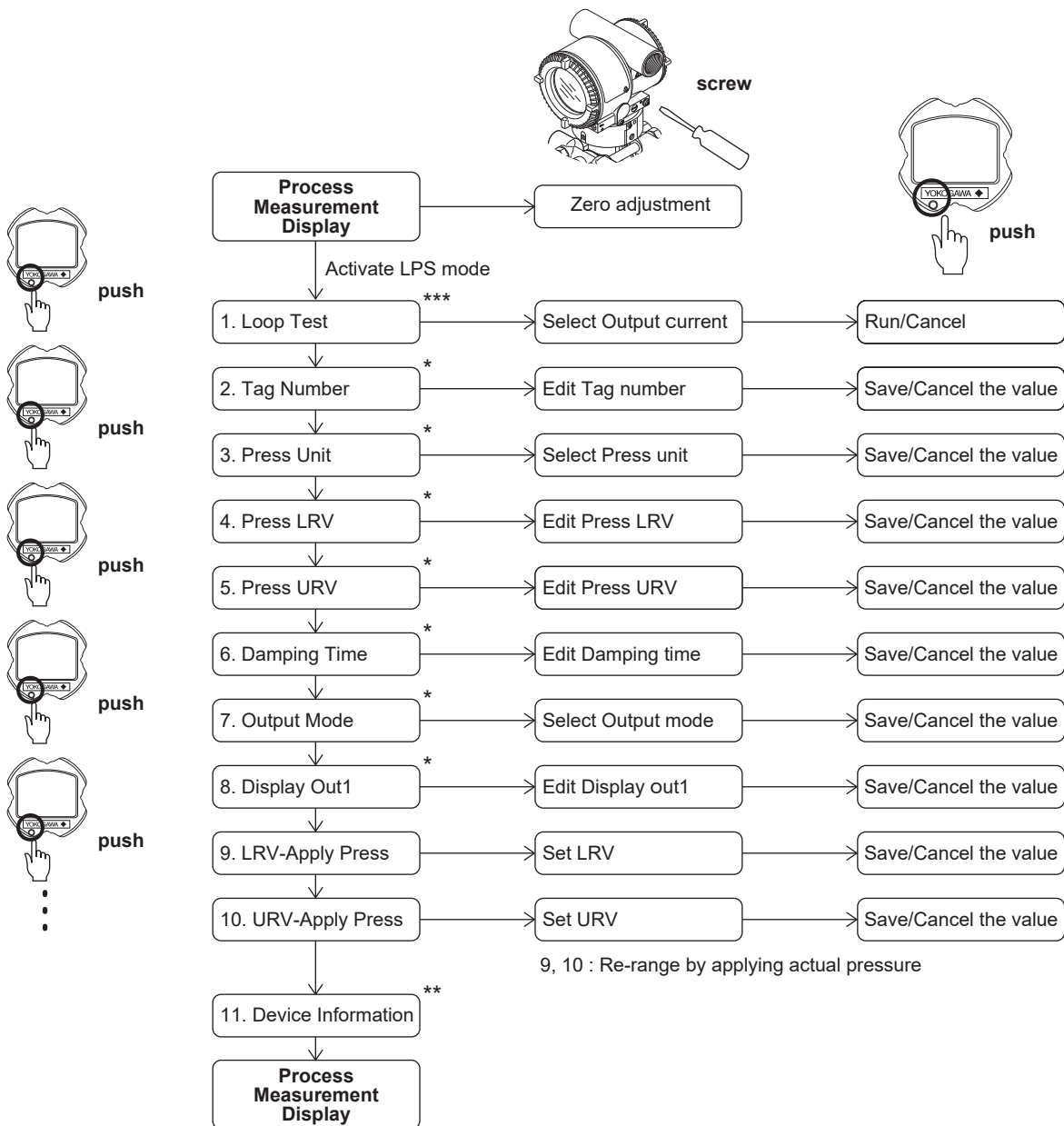

F0712.ai

- *: These parameter configurations are available with the software revision (SOFT REV)2.03 or later. Software revision can be checked via a field communicator (HART/BRAIN) or DTM. Please refer to IM01C25T01 for HART parameter "Software rev" and IM 01C25T03 for BRAIN "SOFT REV."
- **.: This parameter configuration is available with the software revision (SOFT REV) 3.01 or later.
- ***.: This parameter configuration is available with the software revision (SOFT REV) 5.01 or later.

7.7.2 Activating Local Parameter Setting

Press the push button on the integral indicator to activate the Local Parameter Setting mode. The transmitter will exit automatically from the Local Parameter Setting mode if no operation is carried out for 10 minutes.

7.7.3 Parameter Setting Review

Current setting value for the below parameters are shown sequentially by each press of the push button. Loop test, Tag number, Unit, LRV, URV, Damping, Output mode (linear/square root), Display out 1, Re-range by applying actual pressure (LRV/URV) and Device Information.

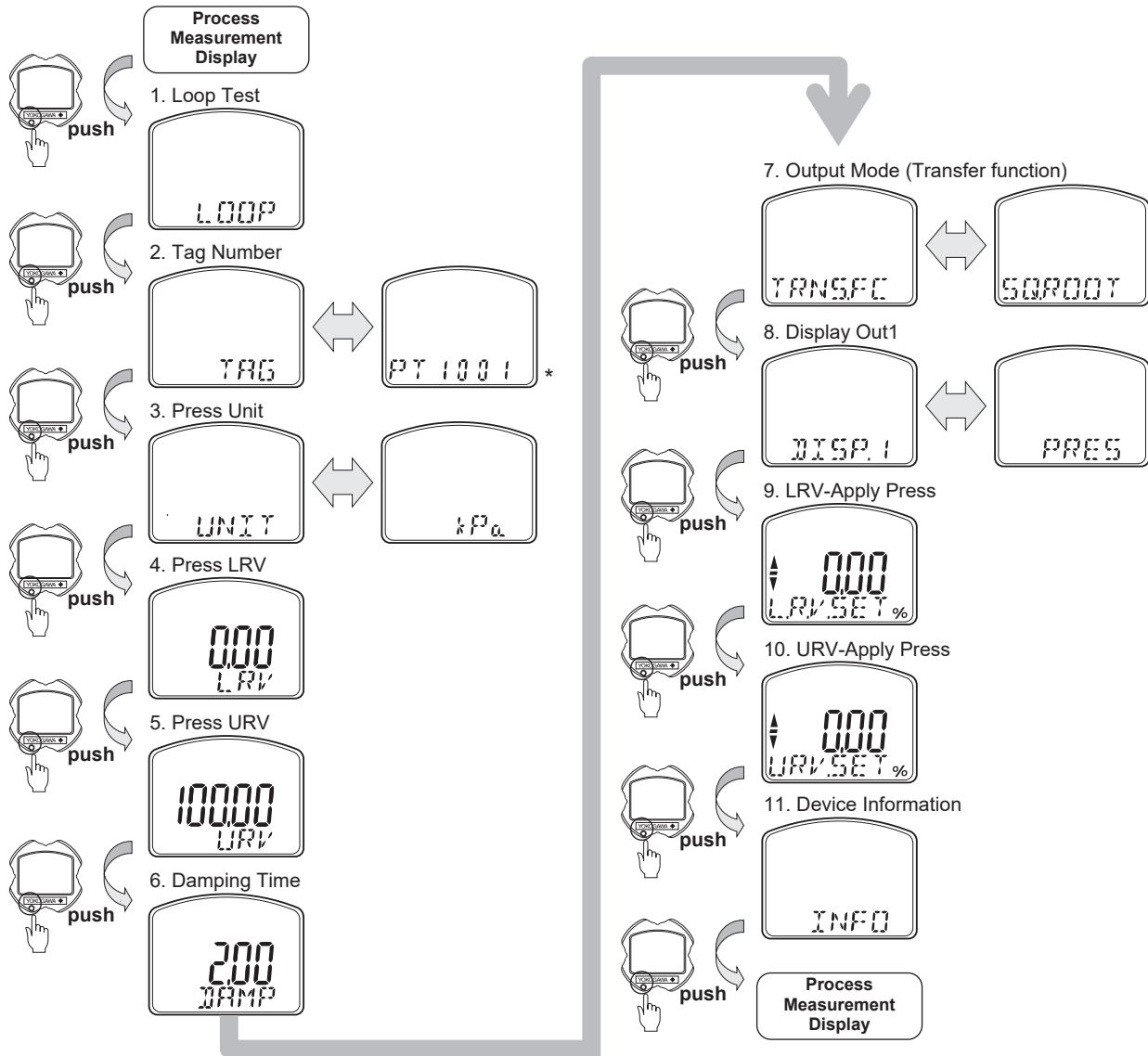

F0713.ai

*: [Software revision: 2.03] Up to 6 characters are shown in the bottom line. To review after the 7th character, turn the zero-adjustment screw and press the push button six times or more.
 [Software revision: 3.01 or later] The display automatically scrolls to show all the characters.

To configure each parameter value, turn the zero-adjustment screw on each parameter screen after activating the Local Parameter Setting mode.

To cancel the Local Parameter Setting configuration, please refer to 7.7.13 Save or Cancel and 7.7.14 Abort Configuration.

7.7.4 Loop Test Configuration

Loop test configuration can be changed as below. Output current value (4 mA, 12 mA or 20 mA) for Loop test can be selected by turning the zero-adjustment screw.

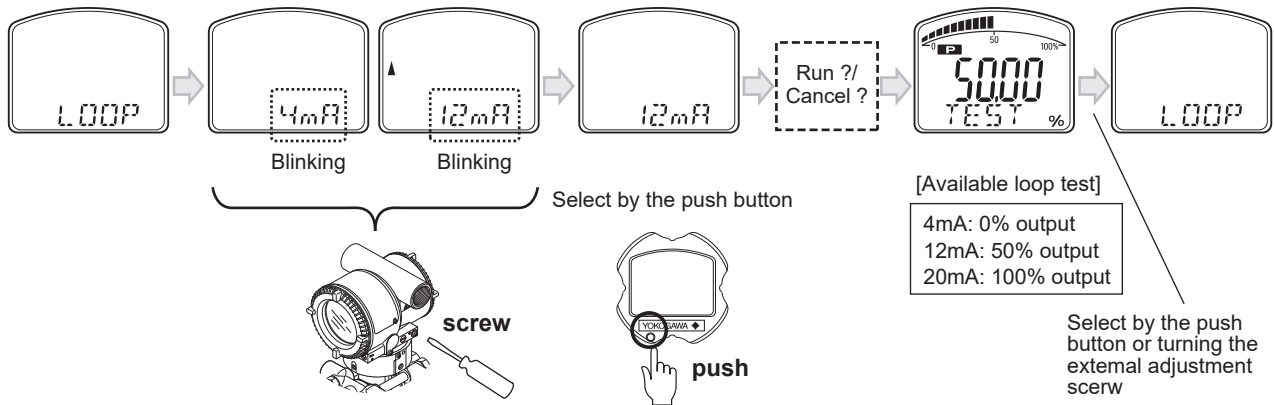

F0721.ai

7.7.5 Tag Number Configuration

Tag Number is edited by turning the zero-adjustment screw. Up to 8 alphanumeric characters for HART or 16 alphanumeric characters for BRAIN can be set.

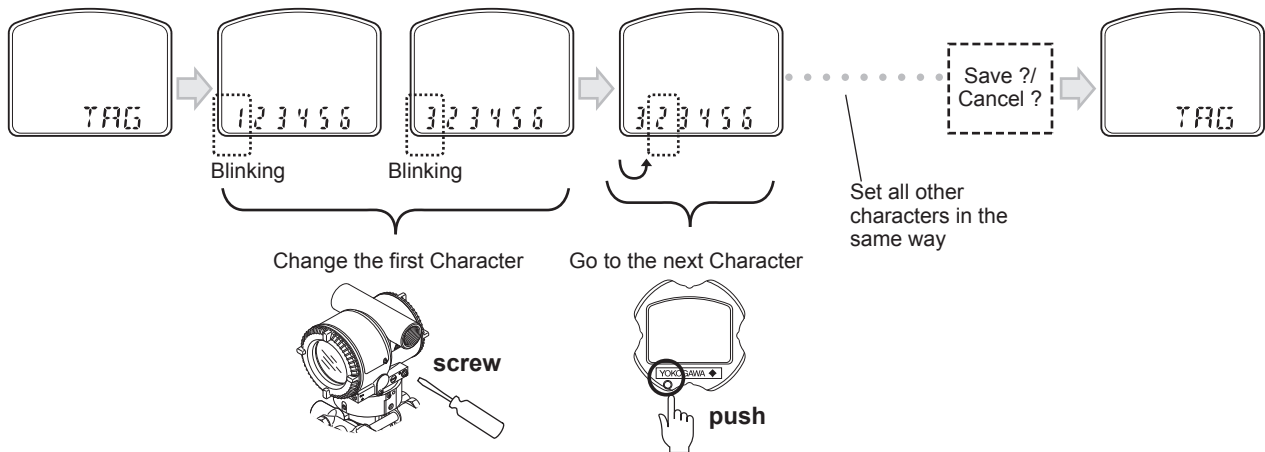

F0714.ai

7.7.6 Pressure Unit Configuration

Pressure unit for the below table can be changed as below. By turning the zero-adjustment screw, user can scroll between the various available pressure units.

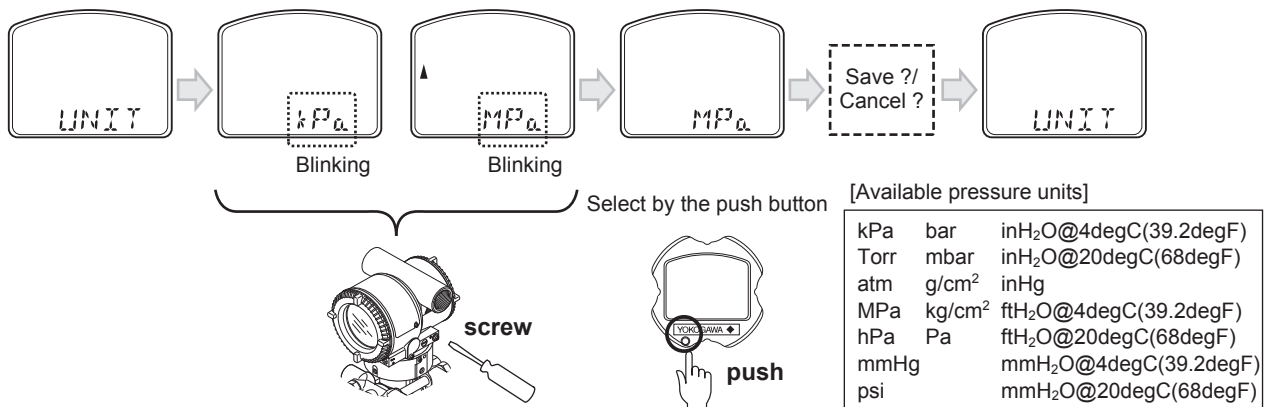

In addition to the above units, mmAq@4degC, mmAq@20degC, mmWG@4degC and mmWG@20degC are available for BRAIN communication type.

F0715.ai

7.7.7 Pressure LRV/URV Configuration

Pressure LRV and URV can be set. The number for each digit is changed by turning the zero-adjustment screw and set by pressing the push button. Please refer to 7.7.8 Damping Time Constant Configuration for how to change the numerical value.

When the setting is out of the limit, an alarm will be generated.

7.7.8 Damping Time Constant Configuration

The damping time constant for the amplifier assembly can be set. Quick Response Parameter is automatically set to ON when the damping time constant is set to less than 0.5 seconds. Damping time constant is rounded off to two decimal places.

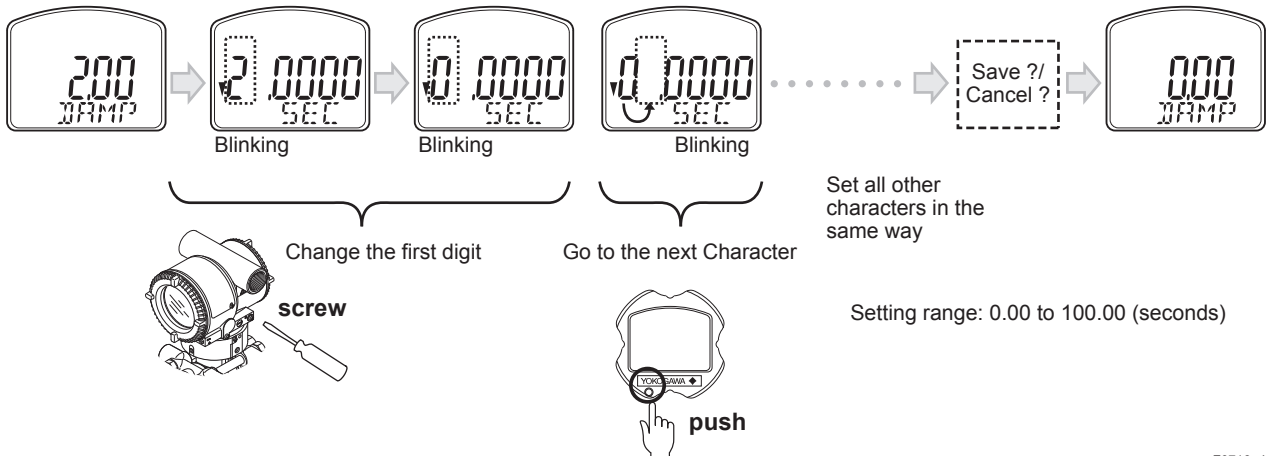

F0716.ai

7.7.9 Output Mode Configuration

Pressure Output Mode (Linear or Sq root) can be selected by turning the zero-adjustment screw. Please refer to 7.7.6 Pressure Unit Configuration for how to select and set the enumerated value.

7.7.10 Display Out 1 Configuration

Display Out1 can be selected by turning the zero-adjustment screw. Please refer to 7.7.6 Pressure Unit Configuration for how to select and set the enumerated value.

7.7.11 Re-range by applying actual pressure (LRV/URV).

This feature allows the lower and upper range values to be setup with the actual input applied.

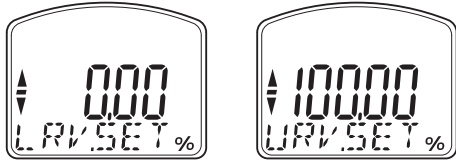

F0717.ai

Follow the procedure below to change the LRV and URV settings.

[Example]

Rerange LRV to 0 and URV to 3 MPa.

- 1) Connect the transmitter and apparatus as shown in Figure 8.1 and warm it up for at least five minutes.
- 2) Press the push-button. The integral indicator then displays “LRV.SET.”
- 3) Apply a pressure of 0 kPa (atmospheric pressure) to the transmitter. (Note 1)
- 4) Turn the zero-adjustment screw in the desired direction. The integral indicator displays the output signal in %. (Note 2)
- 5) Adjust the output signal to 0% (1 V DC) by rotating the zero-adjustment screw. Press the push button to save the value. Doing so completes the LRV setting. (Note 3)
- 6) Press the push-button. The integral indicator then displays “URV.SET.”
- 7) Apply a pressure of 3 MPa to the transmitter. (Note 1)
- 8) Turn the zero-adjustment screw in the desired direction. The integral indicator displays the output signal in %. (Note 2)
- 9) Adjust the output signal to 100% (5 V DC) by rotating the zero-adjustment screw. Press the button to save the value. Doing so completes the URV setting.
- 10) Press the push-button. The transmitter then switches back to the normal operation mode with the measurement range of 0 to 3 MPa.

- Note 1: Wait until the pressure inside the pressure-detector section has stabilized before proceeding to the next step.
- Note 2: If the pressure applied to the transmitter exceeds the previous LRV (or URV), the integral indicator may display error number “AL.30” (In this case, the output signal percent and “AL.30” are displayed alternately every two seconds). Although “AL.30” is displayed, you may proceed to the next step. However, should any other error number be displayed, take the appropriate measure in reference to, “Errors and Countermeasures” in each communication manual.
- Note 3: Changing the lower range value (LRV) also automatically changes the upper range value (URV), keeping the span constant. New URV=previous URV+(new LRV–previous LRV)

7.7.12 Device Information Display

Model name, communication protocol, device revision and software revision are displayed repeatedly.

7.7.13 Save or Cancel

At the end of each parameter setting, select “Save” or “Cancel” by the zero-adjustment screw and press the push button to save or cancel the configuration.

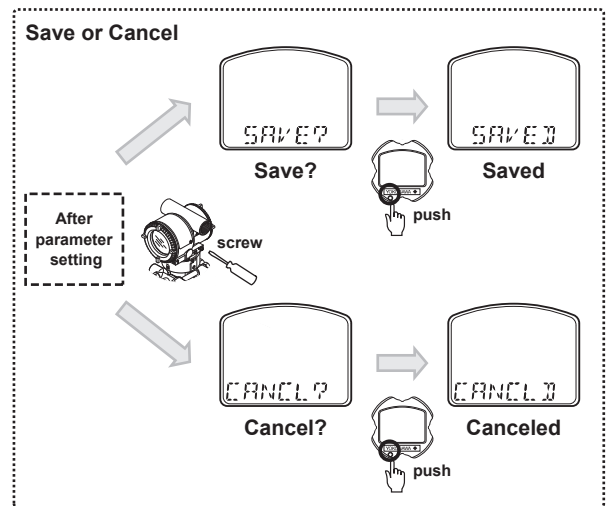

F0718.ai

7.7.14 Abort Configuration

7.7.14.1 Abort Configuration (Menu)

Hold down the push button for over 2 seconds to exit the Local Parameter Setting mode.

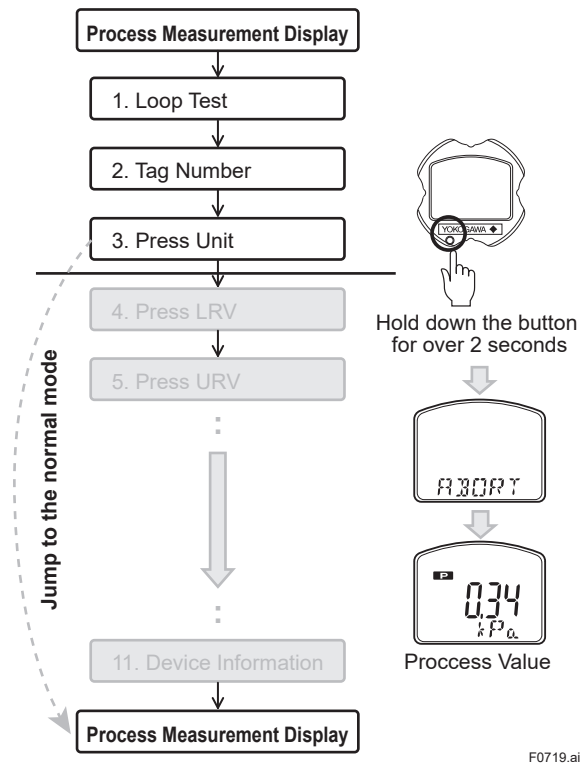

F0719.ai

7.7.14.2 Abort Configuration (Parameter)

To exit the configuration while editing the value, hold down the button for over 2 seconds and select "Save" or "Cancel."

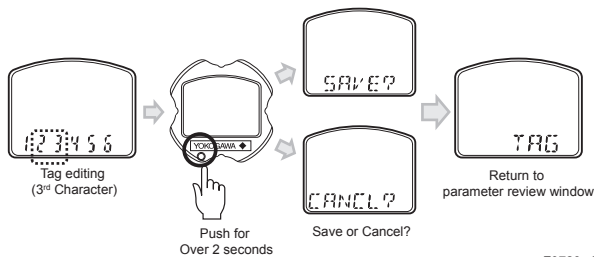

F0720.ai

7.7.15 Local Parameter Setting Lock

To disable parameter changes by the Local Parameter Setting there are three different ways.

	Locked features
Communication Parameter Ext SW =disable (EXT ZERO ADJ = disable)	<ul style="list-style-type: none"> External Zero Adjustment Local Parameter Setting
Communication Parameter Write Protect = On (WRT PROTECT = Yes)	<ul style="list-style-type: none"> Local Parameter Setting All Communication Parameters *
Hardware write protection switch on CPU assembly = D (Disable)	<ul style="list-style-type: none"> Local Parameter Setting All Communication Parameters *

*External Zero Adjustment is unlocked.

The above parameter setting is carried out by using field communicator or DTM. See the user's manual IM 01C25T (HART/BRAIN) for the setting procedure.

Reviewing local parameter setting by push button on the integral indicator is available at any time even when the Local Parameter Setting is locked.

7.7.16 Others

- Difference between BRAIN and HART

	HART	BRAIN
Tag Number	Up to 8 characters can be set	Up to 16 characters can be set
Output Mode (Linear/Sqroot)	"TRNS.FC" shown on the integral indicator	"OUT.MOD" shown on the integral indicator

- The degree of adjustment depends on the speed of turning the adjustment screw. Turn the screw slowly for fine tuning and turn the screw fast for coarse tuning.

8. Maintenance

8.1 Overview



WARNING

Since the accumulated process fluid may be toxic or otherwise harmful, take appropriate care to avoid contact with the body or inhalation of vapors when draining condensate or venting gas from the transmitter pressure-detector section and even after dismounting the instrument from the process line for maintenance.

Maintenance of the transmitter is easy due to its modular construction. This chapter describes the procedures for calibration, adjustment, and the disassembly and reassembly procedures required for component replacement.

Transmitters are precision instruments. Please carefully and thoroughly read the following sections for information on how to properly handle them while performing maintenance.



IMPORTANT

- As a rule, maintenance of this transmitter should be done in a shop that has all the necessary tools.
- The CPU assembly contains sensitive parts that can be damaged by static electricity. Take precautions such as using a grounded wrist strap when handling electronic parts or touching the board circuit patterns. Also be sure to place the removed CPU assembly into a bag with an antistatic coating.

8.2 Calibration Instruments Selection

Table 8.1 lists the instruments that can be used to calibrate a transmitter. When selecting an instrument, consider the required accuracy level. Exercise care when handling these instruments to ensure they maintain the specified accuracy.

8.3 Calibration

Use the procedure below to check instrument operation and accuracy during periodic maintenance or troubleshooting.

- 1) Connect the instruments as shown in figure 8.1 and warm up the instruments for at least five minutes.



IMPORTANT

- Do not perform the calibration procedure until the transmitter is at room temperature.
 - To adjust the transmitter for highest accuracy, make adjustments with the power supply voltage and load resistance including leadwire resistances set close to the conditions under which the transmitter is installed.
 - If the measurement range 0% point is 0 kPa or shifted in the positive direction (suppressed zero), the reference pressure should be applied as shown in the figure. If the measurement range 0% point is shifted in the negative direction (elevated zero), the reference pressure should be applied using a vacuum pump.
- 2) Apply reference pressures of 0%, 50%, and 100% of the measurement range to the transmitter. Calculate the errors (differences between digital voltmeter readings and reference pressures) as the pressure is increased from 0% to 100% and is decreased from 100% to 0%, and confirm that the errors are within the required accuracy.

Table 8.1 Instruments Required for Calibration

Name	Yokogawa-recommended Instrument	Remarks
Power supply	Model SDBT or SDBS distributor	4 to 20 mA DC signal
Load resistor	Model 2792 standard resistor [250 Ω ±0.005%, 3 W] Load adjustment resistor [100 Ω ±1%, 1 W]	
Voltmeter	Model 2501 A digital multimeter Accuracy (10V DC range): ±(0.002% of rdg + 1 dgt)	
Digital manometer	Model MT220 precision digital manometer 1) For 10 kPa class Accuracy: ±(0.015% of rdg + 0.015% of F.S.) for 0 to 10 kPa ±(0.2% of rdg + 0.1% of F.S.) for -10 to 0 kPa 2) For 130 kPa class Accuracy: ±0.02% of rdg for 25 to 130 kPa ±5digits for 0 to 25 kPa ±(0.2% of rdg + 0.1% of F.S.) for -80 to 0 kPa 3) For 700 kPa class Accuracy: ±(0.02% of rdg + 3digits) for 100 to 700 kPa ±5 digits for 0 to 100 kPa ±(0.2% of rdg + 0.1% of F.S.) for -80 to 0 kPa 4) For 3000 kPa class Accuracy: ±(0.02% of rdg + 10 digits) for 0 to 3000 kPa ±(0.2% of rdg + 0.1% of F.S.) for -80 to 0 kPa 5) For 130 kPa abs class Accuracy: ±(0.03% of rdg + 6 digits) for 0 to 130 kPa abs	Select a manometer having a pressure range close to that of the transmitter.
Pressure generator	Model 7674 pneumatic pressure standard for 200 kPa {2 kgf/cm ² }, 25 kPa {2500 mmH ₂ O} Accuracy: ±0.05% of F.S.	Requires air pressure supply.
	Dead weight gauge tester 25 kPa {2500 mmH ₂ O} Accuracy: ±0.03% of setting	Select the one having a pressure range close to that of the transmitter.
Pressure source	Model 6919 pressure regulator (pressure pump) Pressure range: 0 to 133 kPa {1000 mmHg}	Prepare the vacuum pump for negative pressure ranges.

Note: The above table contains the instruments capable of performing calibration to the 0.2% level. Since special maintenance and management procedures involving traceability of each instrument to higher-level standards are required for calibration to the 0.1% or higher level, there may be difficulties in calibration to this level in the field. For calibration to the 0.1% level, contact Yokogawa representatives from which the instrument was purchased or the nearest Yokogawa office.

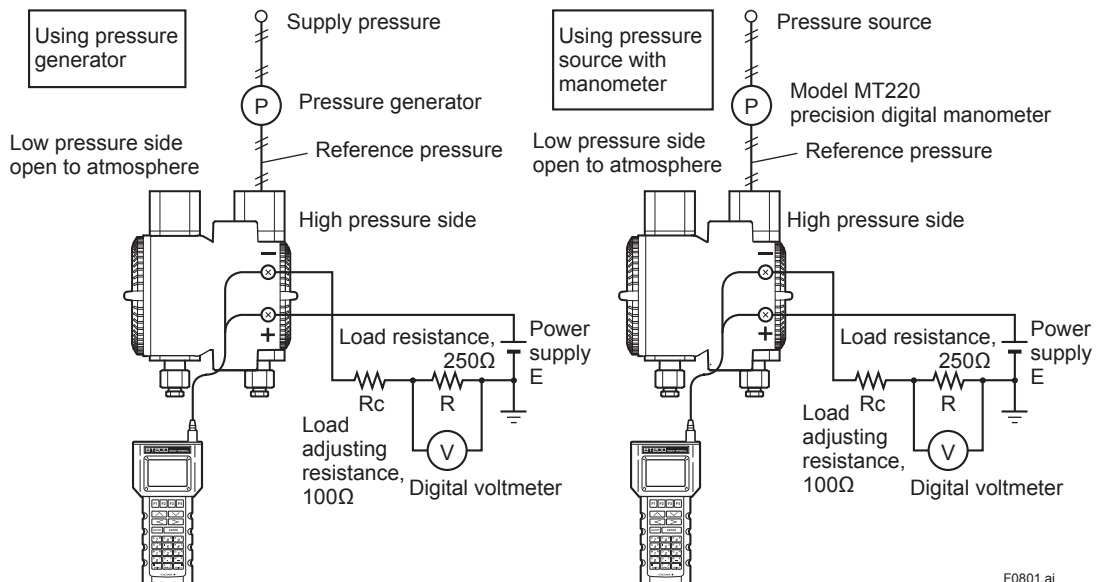

Figure 8.1 Instrument Connections (EJX110A, 4 to 20mA output)

8.4 Disassembly and Reassembly

This section describes procedures for disassembly and reassembly for maintenance and component replacement.

Always turn OFF power and shut off and release pressures before disassembly. Use proper tools for all operations. Table 8.2 shows the tools required.

Table 8.2 Tools for Disassembly and Reassembly

Tool	Quantity	Remarks
Phillips screwdriver	1	JIS B4633, No. 2
Slotted screwdriver	1	
Allen wrenches	3	JIS B4648 One each, nominal 3, 4 and 2.5 mm Allen wrenches
Wrench	1	Width across flats, 17 mm
Torque wrench	1	
Adjustable wrench	1	
Socket wrench	1	Width across flats, 16 mm
Socket driver	1	Width across flats, 5.5 mm
Tweezers	1	

CAUTION

Precautions for ATEX Flameproof Type Transmitters

- Flameproof type transmitters must be, as a rule, removed to a non-hazardous area for maintenance and be disassembled and reassembled to the original state.
- On the flameproof type transmitters the two covers are locked, each by an Allen head bolt (shrouding bolt). When a shrouding bolt is driven clockwise by an Allen wrench, it is going in and cover lock is released, and then the cover can be opened.
When a cover is closed it should be locked by a shrouding bolt without fail. Tighten the shrouding bolt to a torque of 0.7 N·m.

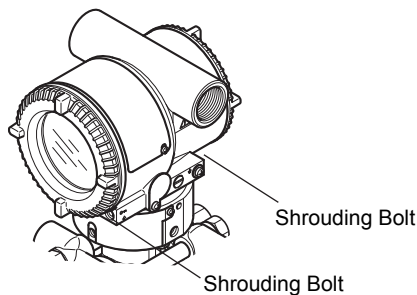

F0802.ai

Figure 8.2 Shrouding Bolts

8.4.1 Replacing the Integral Indicator

CAUTION

Cautions for Explosion-proof/Flameproof Type Transmitters

Users are prohibited by law from modifying the construction of a explosion-proof/flameproof type transmitter. This would invalidate the agency approval for the use of the transmitter in a rated area.

It follows that the user is prohibited from using a explosion-proof/flameproof type transmitter with its integral indicator removed, or from adding an integral indicator to a transmitter. If such modification is absolutely required, contact Yokogawa.

This subsection describes the procedure for replacing an integral indicator. (See figure 8.3)

■ Removing the Integral Indicator

- 1) Remove the cover.
- 2) While supporting the integral indicator with one hand, loosen its two mounting screws.
- 3) Dismount the LCD board assembly from the CPU assembly.
When doing this, carefully pull the LCD board assembly straight forward so as not to damage the connector pins between it and the CPU assembly.

■ Attaching the Integral Indicator

- 1) Align both the LCD board assembly and CPU assembly connectors and engage them.
- 2) Insert and tighten the two mounting screws.
- 3) Replace the cover.

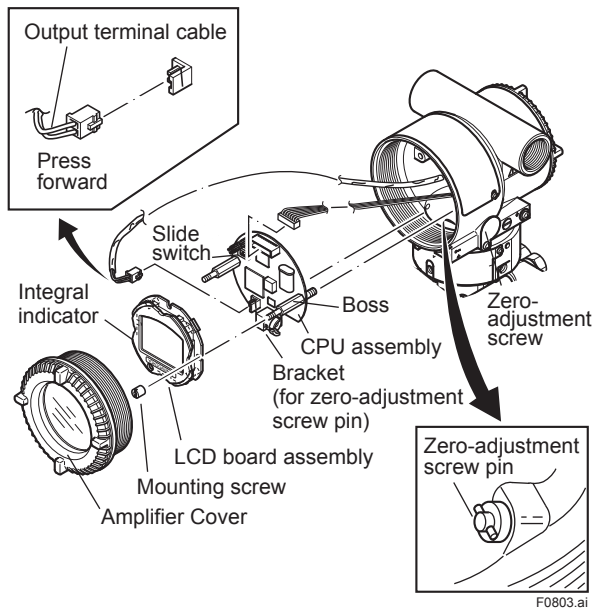

Figure 8.3 Removing and Attaching LCD Board Assembly and CPU Assembly

8.4.2 Replacing the CPU Board Assembly

This subsection describes the procedure for replacing the CPU assembly. (See figure 8.3)

■ Removing the CPU Assembly

- 1) Remove the cover. If an integral indicator is mounted, refer to subsection 8.4.1 and remove the indicator.
- 2) Turn the zero-adjustment screw to the position (where the screw head slot is horizontal) as shown in figure 8.3.
- 3) Disconnect the output terminal cable (cable with brown connector at the end). When doing this, lightly press the side of the CPU assembly connector and pull the cable connector to disengage.
- 4) Use a socket driver (width across flats, 5.5mm) to loosen the two bosses.
- 5) Carefully pull the CPU assembly straight forward to remove it.
- 6) Disconnect the flat cable (cable with white connector at the end) that connects the CPU assembly and the capsule.



NOTE

Be careful not to apply excessive force to the CPU assembly when removing it.

■ Mounting the CPU Assembly

- 1) Connect the flat cable (with white connector) between the CPU assembly and the capsule.
- 2) Connect the output terminal cable (with brown connector).



NOTE

Make certain that the cables do not get pinched between the case and the edge of the CPU assembly.

- 3) Align and engage the zero-adjustment screw pin with the groove on the bracket on the CPU assembly. Then insert the CPU board assembly straight onto the post in the amplifier case.
- 4) Tighten the two bosses. If the transmitter is equipped with an integral indicator, refer to subsection 8.4.1 to mount the indicator.



NOTE

Confirm that the zero-adjustment screw pin is placed properly in the groove on the bracket prior to tightening the two bosses. If it is not, the zero-adjustment mechanism will be damaged.

- 5) Replace the cover.

8.4.3 Replacing the Process Connector Gaskets

This subsection describes process connector gasket replacement. (See Figure 8.4.)

- (a) Loosen the two bolts, and remove the process connectors.
- (b) Replace the process connector gaskets.
- (c) Remount the process connectors. Tighten the bolts securely and uniformly with a torque of 39 to 49 N·m {4 to 5 kgf·m}, and verify that there are no pressure leaks.

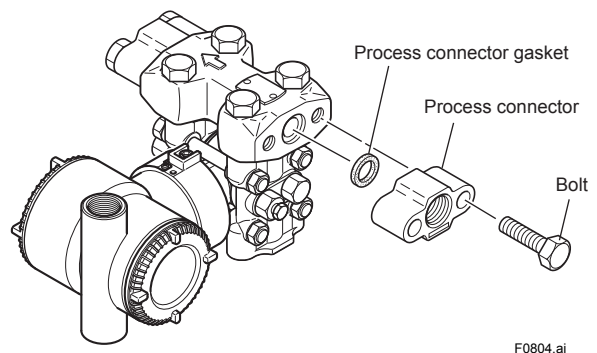

Figure 8.4 Removing and Mounting the Process Connector

8.4.4 Cleaning Manifold Assembly and Replacing Orifice

This subsection describes the procedures for cleaning the manifold assembly and replacing the orifice to change flow rate. (See Figure 8.5.)

■ Removing the Manifold Assembly

- 1) Remove the process connector as shown in Subsection 8.4.3.
- 2) Remove the four bolts that connect the cover flange with the manifold.
- 3) Remove the spacer, orifice, and orifice gasket from inside the manifold.
- 4) Clean the manifold, spacer, and orifice, or replace them as necessary.



IMPORTANT

Exercise care as follows when cleaning the manifold assembly.

- Handle the manifold assembly with care, and be careful not to damage the inner part of the manifold, spacer, and orifice. Be especially careful not to damage or distort the orifice edge (orifice bore).
- Do not use a chlorinated or acidic solution for cleaning.
- Rinse thoroughly with clean water after cleaning.

■ Reassembling the Manifold Assembly

- 1) Reassemble the orifice gasket, orifice, and spacer into the manifold in that order. When reassembling, refer to Figure 8.5 to ensure that they are placed in the correct direction. Replace the orifice gasket with a new gasket.
- 2) Mount the process connector as shown in Subsection 8.4.3.
- 3) Mount the manifold on the cover flange with the four bolts. Tighten the four bolts uniformly to a torque of 39 to 49 N·m {4 to 5 kgf·m}. Replace the manifold gaskets with new gaskets.

- 4) After completing reassembly, a leak test must be performed to verify that there are no pressure leaks.



NOTE

Exercise care as follows when reassembling the manifold assembly. (See Figure 8.5.)

- Be careful not to reassemble the orifice in the wrong direction. Note that the spacer is configured so that it cannot be placed in the reverse direction.
- When mounting the manifold on the cover flange, confirm the indication “flow direction” shown on the manifold surface and the high and low pressure sides of the pressure-detector section.

Mount the manifold so that the upstream side of process fluid flow is located at the high pressure side of the pressure-detector section.

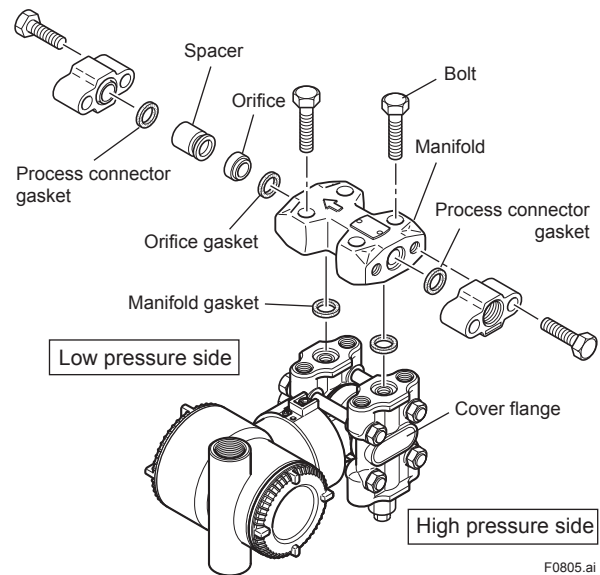

Figure 8.5 Manifold Assembly

F0805.ai

8.4.5 Cleaning and Replacing the Capsule Assembly

This subsection describes the procedures for cleaning and replacing the capsule assembly. (See figure 8.6.)



CAUTION

■ Cautions for Flameproof Type Transmitters

Users are prohibited by law from modifying the construction of a flameproof type transmitter. If you wish to replace the capsule assembly with one of a different measurement range, contact Yokogawa.

The user is permitted, however, to replace a capsule assembly with another of the same measurement range. When doing so, be sure to observe the following.

- The replacement capsule assembly must have the same part number as the one being replaced.
- The section connecting the transmitter and capsule assembly is a critical element in preservation of flameproof performance, and must be checked to verify that it is free of dents, scratches, and other defects.
- After completing maintenance, be sure to securely tighten the setscrews that fasten the transmitter section and pressure-detector section together.

■ Removing the Capsule Assembly



IMPORTANT

Exercise care as follows when cleaning the capsule assembly.

- Handle the capsule assembly with care, and be especially careful not to damage or distort the diaphragms that contact the process fluid.
- Do not use a chlorinated or acidic solution for cleaning.
- Rinse thoroughly with clean water after cleaning.

- 1) Remove the CPU assembly as shown in subsection 8.4.2.
- 2) Remove the two setscrews that connect the transmitter section and pressure-detector section.
- 3) Remove the hexagon-head screw and the stopper.
- 4) Separate the transmitter section and pressure-detector section.
- 5) Remove the nuts from the four flange bolts.
- 6) While supporting the capsule assembly with one hand, remove the cover flange.
- 7) Remove the capsule assembly.
- 8) Clean the capsule assembly or replace with a new one.

■ Reassembling the Capsule Assembly

- 1) Insert the capsule assembly between the flange bolts, paying close attention to the relative positions of the H (high pressure side) and L (low pressure side) marks on the capsule assembly.
Replace the two capsule gaskets with new gaskets.
- 2) Install the cover flange on the high pressure side, and use a torque wrench to tighten the four nuts uniformly to a torque 17 N·m (40 N·m for measurement span code F.)
- 3) After the pressure-detector section has been reassembled, a leak test must be performed to verify that there are no pressure leaks.
- 4) Reattach the transmitter section to the pressure-detector section.
Reattach the stopper with the hexagon-head screw.
- 5) Tighten the two setscrews. (Tighten the screws to a torque of 1.5 N·m)
- 6) Install the CPU assembly according to subsection 8.4.2.
- 7) After completing reassembly, adjust the zero point and recheck the parameters.

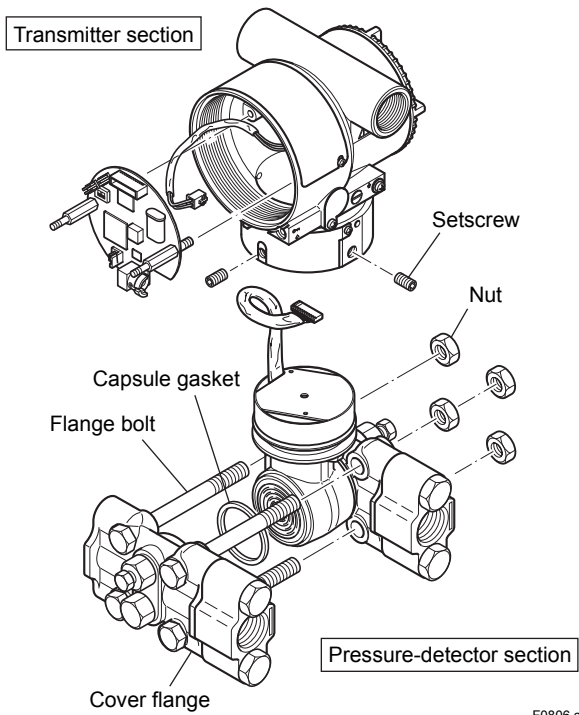

Figure 8.6 Removing and Mounting the Pressure-detector Section

8.5 Troubleshooting

If any abnormality appears in the measured values, use the troubleshooting flow chart below to isolate and remedy the problem. Since some problems have complex causes, these flow charts may not identify all. If you have difficulty isolating or correcting a problem, contact Yokogawa service personnel.

8.5.1 Basic Troubleshooting

First determine whether the process variable is actually abnormal or a problem exists in the measurement system.

If the problem is in the measurement system, isolate the problem and decide what corrective action to take.

This transmitter is equipped with a self-diagnostic function which will be useful in troubleshooting, and the transmitter equipped with an integral indicator will show an alarm code as a result of self-diagnosis.

See subsection 8.5.3 for the list of alarms.

See also each communication manual.

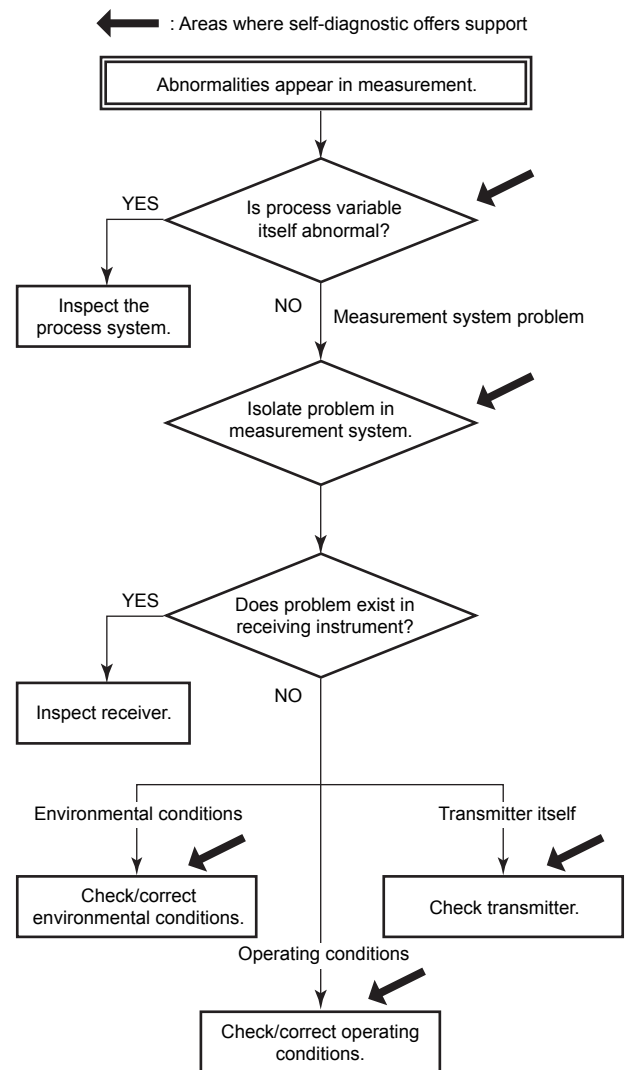
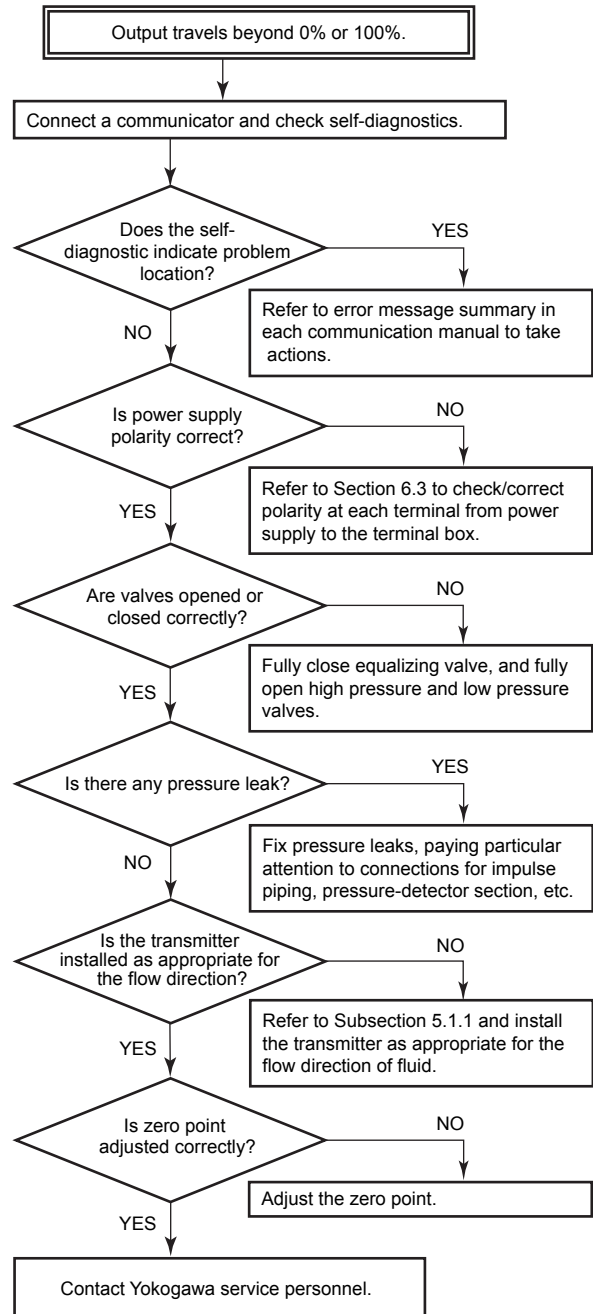
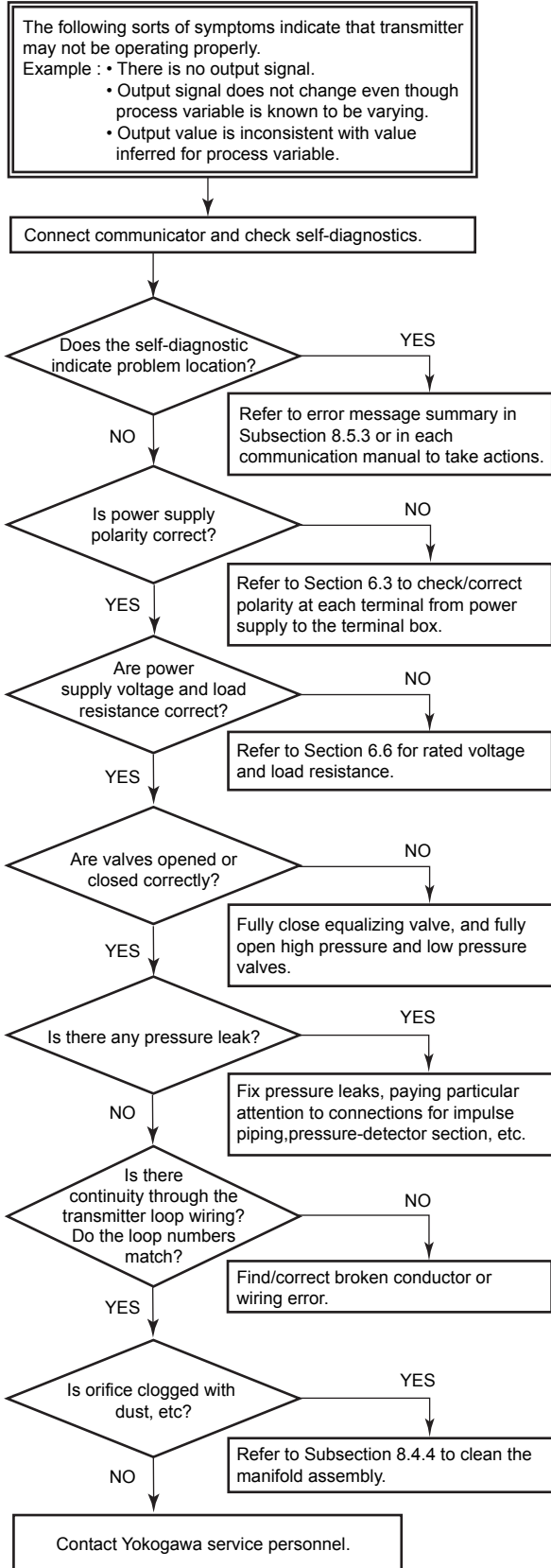
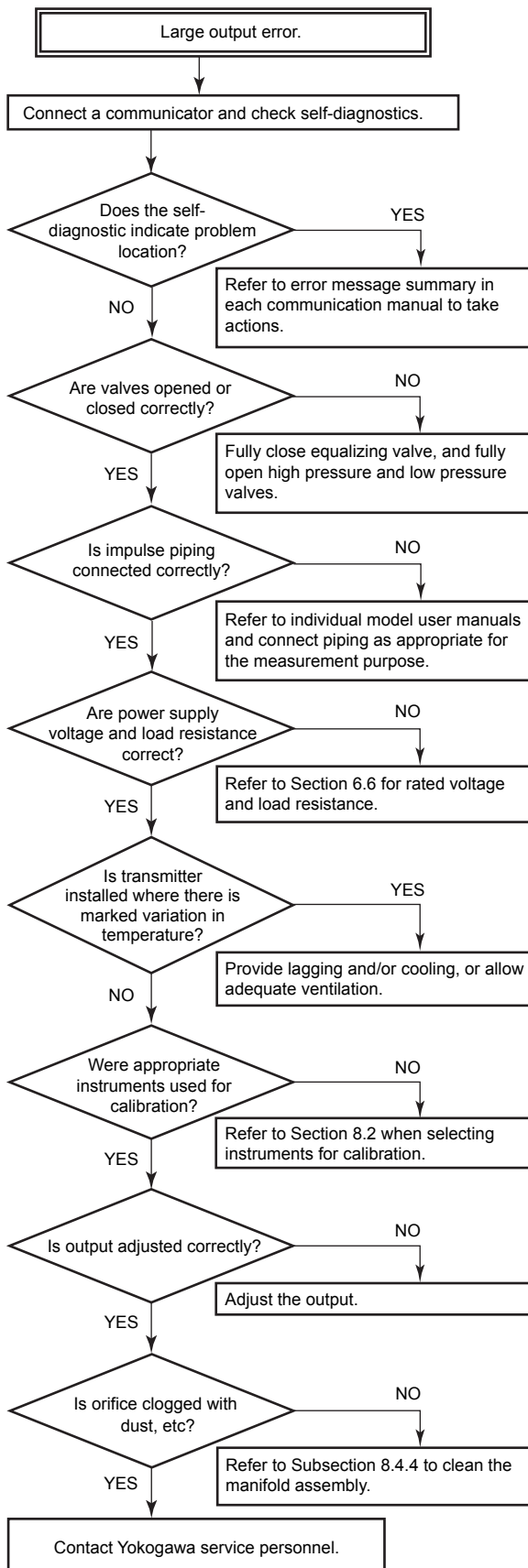

Figure 8.7 Basic Flow and Self-Diagnostics

8.5.2 Troubleshooting Flowcharts





F0810.ai

8.5.3 Alarms and Countermeasures

Table 8.1 Alarm Message Summary

Indicator	Cause	Output Operation during Error	Countermeasure
None			
AL. 01 CAP. ERR	Sensor problem. Capsule temperature sensor problem. Capsule EEPROM problem.	Outputs the signal (Hold, High, or Low) set with parameter.	Replace capsule when error keeps appearing even after restart.
AL. 02 AMP. ERR	Amplifier temperature sensor problem. Amplifier EEPROM problem. Amplifier problem.	Outputs the signal (Hold, High, or Low) set with parameter.	Replace amplifier.
AL. 10 PRESS	Input is outside measurement range limit of capsule.	Outputs high range limit value or low range limit value.	Check input or replace capsule when necessary. Use heat insulation or make lagging to keep temperature within range.
AL. 11 ST. PRSS	Static pressure exceeds limit.	Continues to operate and output.	
AL. 12 CAP. TMP	Capsule temperature is outside range (-50 to 130°C).		
AL. 13 AMP. TMP	Amplifier temperature is outside range (-50 to 95°C)		
AL. 30 RANGE	Output is outside upper or lower range limit value.	Outputs high range limit value or low range limit value.	Check input and range setting, and change them as needed.
AL. 31 SP. RNG	Static pressure exceeds specified range.	Continues to operate and output.	Check input.
AL. 35 *1 P. HI	Input pressure exceeds specified threshold.		
AL. 36 *1 P. LO			
AL. 37 *1 SP. HI	Input static pressure exceeds specified threshold.		
AL. 38 *1 SP. LO			
AL. 39 *1 TMP. HI	Detected temperature exceeds specified threshold.		
AL. 40 *1 TMP. LO			
AL. 50 P. LRV	Specified value is outside of setting range.	Holds output immediately before error occurred.	Check setting and change them as needed.
AL. 51 P. URV			
AL. 52 P. SPN			
AL. 53 P. ADJ		Continues to operate and output.	Check input.
AL. 54 SP. RNG		Continues to operate and output holding static pressure in %.	Check setting and change them as needed.
AL. 55 SP. ADJ		Continues to operate and output.	Check input.
AL. 60 SC. CFG		Specified values or settings to define signal characterizer function do not satisfy the condition.	
AL. 79 OV. DISP	Displayed value exceeds limit.		

*1: These alarms may appear only when process alarm function is activated.

9. General Specifications

Please refer to the following General Specifications list for the specifications, model, suffix and option codes, and external dimensions of each product.

The General Specifications can be downloaded from the website of Yokogawa.

Website address: <https://www.yokogawa.com/solutions/products-platforms/field-instruments/>

■ General Specifications List

Model	Document Title	Document No.
EJX110A	Differential Pressure Transmitter	GS 01C25B01-01EN
EJX120A	Differential Pressure Transmitter	GS 01C25B03-01EN
EJX130A	Differential Pressure Transmitter	GS 01C25B04-01EN
EJX210A	Flange Mounted Differential Pressure Transmitter	GS 01C25C01-01EN
EJX310A	Absolute Pressure Transmitter	GS 01C25D01-01EN
EJX430A	Gauge Pressure Transmitter	GS 01C25E01-01EN
EJX440A	Gauge Pressure Transmitter	GS 01C25E02-01EN
EJX510A, EJX530A	Absolute and Gauge Pressure Transmitters	GS 01C25F01-01EN
EJX610A, EJX630A	Absolute and Gauge Pressure Transmitters	GS 01C25F05-01EN
EJX118A	Diaphragm Sealed Differential Pressure Transmitter	GS 01C25H01-01EN
EJX118A	Diaphragm Sealed Differential Pressure Transmitter (Inner Diaphragm type)	GS 01C25H01-11EN
EJX438A	Diaphragm Sealed Gauge Pressure Transmitter	GS 01C25J03-01EN
EJX438A	Diaphragm Sealed Gauge Pressure Transmitter (Inner Diaphragm type)	GS 01C25J03-11EN
EJX115A	Low Flow Transmitter	GS 01C25K01-01EN
EJX910A	Multivariable Transmitter	GS 01C25R01-01EN
EJX930A	Multivariable Transmitter	GS 01C25R04-01EN
EJXC50A, EJXC40A, EJAC50E, C20FE, C20FW, C10FR, EJXC80A, EJAC80E, C81FA, C82FA, C81FD, C82FD, C30SW, C30SE, C80FW, C80FE, EJXC81A, EJAC81E, C70SE, C70SW	Diaphragm Seal System	GS 01C25W01-01EN
EJXC40A	Digital Remote Sensor	GS 01C25W05-01EN
EJX110A, EJX130A	Differential Pressure Transmitter High Damping Capsule (Option Code: /HD)	GS 01C25V01-01EN
EJX110A	Differential Pressure Transmitters High Damping Capsule (General) (Option Code: /HD2)	GS 01C25V02-01EN
EJX-A, EJA-E	Explosion Protected Type and Marine Certificate Type	GS 01C25A20-01EN
EJA110E	Differential Pressure Transmitter	GS 01C31B01-01EN
EJA120E	Differential Pressure Transmitter	GS 01C31B03-01EN
EJA130E	Differential Pressure Transmitter	GS 01C31B04-01EN
EJA210E	Flange Mounted Differential Pressure Transmitter	GS 01C31C01-01EN
EJA310E	Absolute Pressure Transmitter	GS 01C31D01-01EN
EJA430E	Gauge Pressure Transmitter	GS 01C31E01-01EN
EJA440E	Gauge Pressure Transmitter	GS 01C31E02-01EN
EJA510E, EJA530E	Absolute Pressure Transmitter and Gauge Pressure Transmitter	GS 01C31F01-01EN
EJA118E	Diaphragm Sealed Differential Pressure Transmitter	GS 01C31H01-01EN
EJA118E	Diaphragm Sealed Differential Pressure Transmitter (Inner Diaphragm type)	GS 01C31H01-11EN
EJA438E	Diaphragm Sealed Gauge Pressure Transmitter	GS 01C31J03-01EN
EJA438E	Diaphragm Sealed Gauge Pressure Transmitter (Inner Diaphragm type)	GS 01C31J03-11EN
EJA115E	Low Flow Transmitter	GS 01C31K01-01EN
EJAC60E, EJA560E	Hygienic Adapter System (Fluidless Type) Hygienic Gauge Pressure Transmitter (Fluidless Type)	GS 01C31Y01-01EN
EJA110E, EJA130E	Differential Pressure Transmitter High Damping Capsule (Option Code: /HD)	GS 01C31V01-01EN
EJA110E	Differential Pressure Transmitters High Damping Capsule (General) (Option Code: /HD2)	GS 01C31V02-01EN

If you cannot find it on our website, please contact YOKOGAWA office.

Revision Information

- Title : Low Flow Transmitter
EJX115A and EJA115E
- Manual No. : IM 01C25K01-01E

Edition	Date	Page	Revised Item
1st	July 2008	—	New publication
2nd	Aug. 2009	2-1 2-12 9-3 9-5	2.1 • Replace a name plate. 2.10 • Revise standards. 2.11 • Revise information of PED. 9.2 • Modify descriptions of materials. 9.3 • Add /A1 and /DG6.
3rd	Apr. 2010	2-1 2-4 to 2-11 9-3 9-5 9-7	2.3 • Add limitation of ambient temperature for /HE. 2.9 • Add limitation of ambient temperature for /HE. 9.1 • Add material for cover O-rings 9.3 • Add /HE. 9.4 • Correct dimensions.
4th	Mar. 2012	2-3 9-3 9-4	2.9 • Add note for blind plugs. 9.1 • Change description for a plate material. 9.2 • Add amplifier housing code 3.
5th	June 2012	— 1-1 2.3 to 2.12 2-7 to 2-10 8-6 9.1 to end	• Add EJA115E. Delete measurement span code L and Add measurement span code F. • Add Note. Add model name of EJA115E. • Delete /V1U. • Delete /KS2, /KF21, and /KU21. Add /KS21, /KF22, and /KU22. • Add note for measurement span code F. • Add information for EJA115E. Delete output signal code L and add measurement span code F.
6th	June 2013	— 2-3 2-6, 2-7 2-8 to 2-11 9-4 9-5 9-7 to 9-8	• Add note for PROFIBUS PA communication type. • Add note for multiple approval type. • Correct CSA applicable standards. 2.9.2 • Replace ATEX type n by ATEX Intrinsically safe Ex ic. 2.9.3 • Add note for CE marking notified body number. 9.2 • Add PROFIBUS PA communication type. 9.3 • Replace ATEX type n by ATEX Intrinsically safe Ex ic. 9.4 • Add /V1U1. • Add not for shrouding bolt.
7th	June 2014	1-2 2-6 2-13 6-1 to 6-4 6-1 6-2, 7-1 7-6 to 7-11 9-4 9-7	1. • Add note for symbols. 2.9.2 • Revise category for CSA Nonincendive. 2.12 • Update safety requirement standard. 6. • Revise drawings and symbols for terminal. 6.3.1 • Add note for power supply. Add note for BRAIN communication. 7.7 • Add local parameter setting function. 9.2 • Revise wetted parts material for capsule. 9.4 • Change terminal drawing.
8th	Oct. 2014	2-3 2-5 2-7, 2-8 2-10 2-13 to 2-14 2-14 6-1 6-2 6-3 to 6-4 6-5 7-8 7-9 7-10 7-11 8-9 9-1 to 9-2 9-3	2.8 • Add information for 1 to 5 V output. 2.9.1 • Add information for 1 to 5 V output. 2.9.2 • Add information for 1 to 5 V output. 2.9.3 • Add information for 1 to 5 V output. 2.9.4 • Add EPL code. Revise applicable standard. Add information for 1 to 5 V output. Add note for electro static charge. Add electrical connection. 2.10 • Add standard for PROFIBUS. 6.3 • Add Figure 6.1 Terminal. 6.3.3 • Add information for 1 to 5 V output. 6.4 • Add information for 1 to 5 V output. 6.6 • Add applicability. 7.7.1 • Add "10.Device information" in Figure 7.9. 7.7.3 • Add note in the figure. 7.7 • Add 7.7.6 Pressure LRV/URV Configuration. 7.7 • Add 7.7.8 Output Mode Configuration and 7.7.9 Display Out 1 Configuration. 8.5.3 • Correct AL31 output operation. 9.1 • Add information for 1 to 5 V output. • Add EMC standard for PROFIBUS and EMI specification.

Edition	Date	Page	Revised Item
8th	Oct. 2014	9-4 9-5 9-8	9.2 • Add output signal code Q 9.3 • Revise the description for SU2 and SF2. 9.4 • Add information for 1 to 5 V output.
9th	July 2015	1-2 1-3 2-1 2-5, 2-7, 2-9, 2-14 2-6, 2-7 2-12 2-12 to 2-13 2-15 2-16 7-7 7-8 9-3 9-4 9-5	1.1 • Add trademark statement. 2.1 • Add (g) and (h). 2.1 • Replace Figure 2.2. 2.1 • Delete /V1F. 2.9.2 • Add "No.61010-2-030." 2.9.3 (6) • Replace nameplate. 2.9.4 • Add SU21. Add a and b. 2.10 • Change the note for EN 61326-2-5. 2.12 • Add C22.2 standards. 7.7.1 • Delete note for -Q in Figure 7.7. 7.7.3 • Change note in the figure. 9.1 • Revise descriptions for EMC conformity standards. 9.2 • Delete #. Add material for mounting bracket code D and K. 9.3 • Add SU21.
10th	Nov. 2019	Toc-3, 1-1 1-1 1-4 2-1, 4-2, 7-1 2-3 2-4 to 2-15 2-5 2-16 4-3 6-1 6-4 7-3 7-10 7-11 7-12 7-14 7-15 9-1 to 9-10	1. • Change the description for using the transmitters in Safety Instrumented Systems (SIS) application. 1. • Add style code S2 for EJA115E. 1. • Add a note for Regarding This Manual. 1. • Add (i) Control of Pollution Caused by the product. 2.8 • Change the figure of Mounting bracket(L-type). 2.8 • Change the value of dielectric strength test: 10mA→25mA 2.9.1 • 2.9 revised the description. 2.10 • Changed the applicable standard for FM Explosionproof Type. 2.10 • Deleted (for use in industrial locations) 2.10 • Add CAUTION. 2.11 • Change the description of (1) and (2). 2.11 • Add 2.12 EU RoHS Directive. 2.13 • Change the applicable standard. 2.13 • Delete Altitude of installation site. 4.5 • Change the description. 4.5 • Add WARNING. 6.1 • Delete silicone group 6.4.2 • Delete the description about non-hardening sealant for flameproof type. 7.2 • Add note. 7.7.1 • Add Loop test description, figure and notes. 7.7.3 • Add Loop test description and figure. 7.7.3 • Add 7.7.4 Loop Test Configuration. 7.7.12 • Add Device Information Display. 7.7.14.1 • Change the figure. 9. • Delete the description for general specifications and add the General Specifications list.
11th	Apr. 2020	2-6 to 2-9 2-10, 2-11, 2-13 2-16 2-17	2.9.2 • Updated the description for CSA Certification. 2.9.3 • Updated the description for ATEX Certification. 2.10 • Added some information for EMC Conformity Standards. 2.13 • Added (3) and (4).
12th	July 2021	2-9 2-10 2-12 2-13 2-13 2-13 2-17	2.9.3 a • Update all the descriptions. 2.9.3 b • Update marking code. 2.9.3 c • Update all the descriptions. 2.9.3 (2) • Delete screw size and marking. Delete WARNING. 2.9.3 (3) • Update tag plates. 2.9.4 a • Update all the descriptions. 2.12 • Change EU RoHS Directive.
13th	Jan. 2023	1-4 2-1 2-4 2-13 2-16 2-19 3-1 4-2 6-1 6-4 7-3 7-9	1.1 (h) • Add description about importer. 2. • Add information about bracket code P. 2.9 • Add information to CAUTION. 2.9.4 • Add "SU22". 2.9.4 • Add "d. IECEx Flameproof Type." 2.12 • Add USA to the production site. 3. • Add note for /CJ and /CK. 4.2 • Add position adjustable bracket to Figure 4.2. 4.2 • Add "4.2.1 How to install the position adjustable bracket" 6.1 • dust cap → dust cap(plug) 6.4.2 (2) • Add IMPORATNT for flameproof type. 7.2 • Add note for /CJ and /CK in IMPORTANT. 7.7 • Add note for /CJ and /CK in IMPORTANT.