

\* The direction of cable entry changes as shown left depending on the designation of the optional code RH with its rotational specification.

Unit: mm (approx. in.)

Model	Process Connection Code	BG1																					
		CG1																					
		080	080	100	100	100	100	125	125	125	125	150	150	150	200	200	200	250	250	250			
	Size Code	80	80	100	100	100	100	125	125	125	125	150	150	150	200	200	200	250	250	250			
	Size	(3)	(3)	(4)	(4)	(4)	(4)	(5)	(5)	(5)	(5)	(6)	(6)	(6)	(8)	(8)	(8)	(10)	(10)	(10)			
	Lining Code	F	U,H,D	F	U	H	D	F	U	H	D	F	U	H,D	F	U	H,D	F	U	H,D			
Remote Sensor	Lay Length (*1) (*5)	L	198 (7.78)	198 (7.78)	248 (9.74)	248 (9.74)	248 (9.74)	248 (9.74)	248 (9.74)	248 (9.74)	248 (9.74)	248 (9.74)	248 (9.74)	299 (11.75)	299 (11.75)	299 (11.75)	349 (13.72)	349 (13.72)	349 (13.72)	448 (17.62)	448 (17.62)	448 (17.62)	
	Flange Outer Diameter	øD	211 (8.31)	211 (8.31)	238 (9.37)	238 (9.37)	238 (9.37)	238 (9.37)	263 (10.35)	263 (10.35)	263 (10.35)	263 (10.35)	263 (10.35)	290 (11.42)	290 (11.42)	290 (11.42)	342 (13.46)	342 (13.46)	342 (13.46)	410 (16.14)	410 (16.14)	410 (16.14)	
	Flange Thickness (incl. lining flare)	t	24.5 (0.96)	23.0 (0.91)	24.5 (0.96)	23.0 (0.91)	23.0 (0.91)	23.0 (0.91)	26.5 (1.04)	25.0 (0.98)	25.0 (0.98)	25.0 (0.98)	25.0 (0.98)	27.0 (1.06)	27.0 (1.06)	27.0 (1.06)	27.0 (1.06)	27.0 (1.06)	27.0 (1.06)	30.0 (1.18)	30.0 (1.18)	30.0 (1.18)	
	Lining Inner Diameter	ød	75 (2.96)	73 (2.87)	100 (3.95)	97 (3.82)	98 (3.87)	96 (3.79)	125 (4.91)	121 (4.76)	123 (4.83)	121 (4.75)	149 (5.87)	145 (5.71)	147 (5.80)	200 (7.89)	194 (7.63)	198 (7.81)	248 (9.78)	242 (9.53)	247 (9.74)		
	Bolt Circle Diameter	øC	168 (6.61)	168 (6.61)	195 (7.68)	195 (7.68)	195 (7.68)	195 (7.68)	195 (7.68)	220 (8.66)	220 (8.66)	220 (8.66)	220 (8.66)	247 (9.72)	247 (9.72)	247 (9.72)	299 (11.77)	299 (11.77)	299 (11.77)	360 (14.17)	360 (14.17)	360 (14.17)	
	Bolt Hole Interval	ø	45	45	45	45	45	45	30	30	30	30	30	30	30	22.5	22.5	22.5	22.5	22.5	22.5	22.5	
	Bolt Hole Diameter	øh	19 (0.75)	19 (0.75)	19 (0.75)	19 (0.75)	19 (0.75)	19 (0.75)	19 (0.75)	19 (0.75)	19 (0.75)	19 (0.75)	19 (0.75)	19 (0.75)	19 (0.75)	19 (0.75)	19 (0.75)	19 (0.75)	19 (0.75)	19 (0.75)	23 (0.91)	23 (0.91)	23 (0.91)
	Number of Bolt Holes	N	4	4	4	4	4	4	6	6	6	6	6	6	6	6	6	8	8	8	8	8	8
	Height	H1	220 (8.66)	220 (8.66)	243 (9.57)	243 (9.57)	243 (9.57)	243 (9.57)	270 (10.63)	270 (10.63)	270 (10.63)	270 (10.63)	270 (10.63)	288 (11.32)	288 (11.32)	288 (11.32)	339 (13.33)	339 (13.33)	339 (13.33)	403 (15.88)	403 (15.88)	403 (15.88)	
	Height	H2	114 (4.49)	114 (4.49)	124 (4.88)	124 (4.88)	124 (4.88)	124 (4.88)	138 (5.43)	138 (5.43)	138 (5.43)	138 (5.43)	143 (5.61)	143 (5.61)	143 (5.61)	168 (6.60)	168 (6.60)	168 (6.60)	198 (7.81)	198 (7.81)	198 (7.81)		
Height	H3	-	-	-	-	-	-	-	-	-	-	-	-	-	-	-	-	-	-	461 (18.15)	461 (18.15)	461 (18.15)	
Remote Sensor	Maximum Height	Hr	337 (13.27)	337 (13.27)	360 (14.17)	360 (14.17)	360 (14.17)	360 (14.17)	387 (15.24)	387 (15.24)	387 (15.24)	387 (15.24)	405 (15.94)	405 (15.94)	405 (15.94)	456 (17.95)	456 (17.95)	456 (17.95)	521 (20.50)	521 (20.50)	521 (20.50)		
	Approx. Weight, Unit: kg (lb) (*2)		12.8 (28.2)	12.8 (28.2)	16.1 (35.5)	16.1 (35.5)	16.1 (35.5)	16.1 (35.5)	21.2 (46.7)	21.2 (46.7)	21.2 (46.7)	21.2 (46.7)	29 (64.0)	28 (61.8)	28 (61.8)	40 (88.3)	40 (88.3)	40 (88.3)	56 (123.5)	56 (123.5)	56 (123.5)		
Integral Flowmeter	Maximum Height	Hi	382 (15.04)	382 (15.04)	405 (15.94)	405 (15.94)	405 (15.94)	405 (15.94)	432 (17.01)	432 (17.01)	432 (17.01)	432 (17.01)	450 (17.70)	450 (17.70)	450 (17.70)	501 (19.71)	501 (19.71)	501 (19.71)	565 (22.26)	565 (22.26)	565 (22.26)		
	Approx. Weight, Unit: kg (lb)		15.3 (33.7)	15.3 (33.7)	18.7 (41.2)	18.7 (41.2)	18.7 (41.2)	18.7 (41.2)	23.6 (52.0)	23.6 (52.0)	23.6 (52.0)	23.6 (52.0)	31 (68.4)	31 (68.4)	31 (68.4)	42 (92.7)	42 (92.7)	42 (92.7)	70 (154.5)	70 (154.5)	69 (152.3)		
Grounding rings thin type (GRL, GRH) (*1) (*3)			-	+2 (+0.08)	-	+2 (+0.08)	-	+2 (+0.08)	-	+2 (+0.08)	-	+2 (+0.08)	-	+2 (+0.08)	-	+2 (+0.08)	-	+2 (+0.08)	-	+2 (+0.08)	-	+4 (+0.16)	
Grounding rings thick type (GRN, GRJ) (*1) (*4)			+6 (+0.24)	+6 (+0.24)	+6 (+0.24)	+6 (+0.24)	+6 (+0.24)	+6 (+0.24)	+6 (+0.24)	+6 (+0.24)	+6 (+0.24)	+6 (+0.24)	+6 (+0.24)	+6 (+0.24)	+6 (+0.24)	+6 (+0.24)	+6 (+0.24)	+6 (+0.24)	+6 (+0.24)	+6 (+0.24)	+6 (+0.24)	+6 (+0.24)	
Grounding rings thick type (GRN, GRJ) with gaskets (GA, GC, GD) (*1)			+10 (+0.39)	-	+10 (+0.39)	-	-	-	+10 (+0.39)	-	-	-	-	-	-	-	-	-	-	-	-	-	

- \*1: Add the value above (which is the total of both ends) to the lay length "L" when selecting optional grounding rings with/without gaskets. Also, the thickness of customer supplied gaskets should be added for getting the total lay length.
- \*2: When submersible use or optional code DHC is selected, waterproof glands with union joints and cables are attached. When the cable length is 30-meters, add 9.5 kg (20.9 lb) to the weight in the table.
- \*3: These grounding rings (GRL, GRH) are not applied to lining code F nor H but for U and D.
- \*4: When applying these grounding rings (GRN, GRJ) to lining code F or H, gaskets supplied by customer are necessary, except for lining code F with sizes 125 mm (5 in.) or less. For sizes up to 125 mm (5 in.), recommended thickness of the gasket is 2 mm (0.08 in.) per one, bringing 4 mm (0.16 in.) per two, and for sizes 150 mm (6 in.) and above, it is 3 to 5 mm (0.12 to 0.20 in.) per one, bringing 6 to 10 mm (0.24 to 0.39 in.) per two, to be additionally added for getting the total lay length.
- \*5: The tolerance of the lay length "L" is as follows.
  - Size 25 to 200 mm (1 to 8 in.): 0/-3 mm
  - Size 250 to 400 mm (10 to 16 in.): 0/-5 mm

Unit: mm (approx. in.)

Model	Process Connection Code		BG1								
			CG1								
	Size Code		300	300	300	350	350	350	400	400	400
	Size		300 (12)	300 (12)	300 (12)	350 (14)	350 (14)	350 (14)	400 (16)	400 (16)	400 (16)
	Lining Code		F	U	H, D	F	U	H, D	F	U	H, D
Remote Sensor	Lay Length (*1) (*5)	L	498 (19.59)	498 (19.59)	498 (19.59)	548 (21.56)	548 (21.56)	548 (21.56)	598 (23.52)	598 (23.52)	598 (23.52)
	Flange Outer Diameter	øD	464 (18.27)	464 (18.27)	464 (18.27)	530 (20.87)	530 (20.87)	530 (20.87)	582 (22.91)	582 (22.91)	582 (22.91)
	Flange Thickness (incl. lining flare)	t	29.0 (1.14)	29.0 (1.14)	29.0 (1.14)	31.5 (1.24)	31.5 (1.24)	31.5 (1.24)	31.5 (1.24)	31.5 (1.24)	31.5 (1.24)
	Lining Inner Diameter	ød	300 (11.79)	292 (11.48)	299 (11.75)	330 (12.97)	323 (12.70)	330 (12.97)	381 (14.98)	373 (14.67)	384 (15.13)
	Bolt	øC	414 (16.30)	414 (16.30)	414 (16.30)	472 (18.58)	472 (18.58)	472 (18.58)	524 (20.63)	524 (20.63)	524 (20.63)
	Circle Diameter		18 (0.71)	18 (0.71)	18 (0.71)	18 (0.71)	18 (0.71)	18 (0.71)	15 (0.59)	15 (0.59)	15 (0.59)
	Bolt Hole Interval	θ°	23 (0.91)	23 (0.91)	23 (0.91)	25 (0.98)	25 (0.98)	25 (0.98)	25 (0.98)	25 (0.98)	25 (0.98)
	Bolt Hole Diameter	øh	10 (0.39)	10 (0.39)	10 (0.39)	10 (0.39)	10 (0.39)	10 (0.39)	12 (0.47)	12 (0.47)	12 (0.47)
	Number of Bolt Holes	N	455 (17.90)	455 (17.90)	455 (17.90)	509 (20.04)	509 (20.04)	509 (20.04)	563 (22.16)	563 (22.16)	563 (22.16)
	Height	H1	223 (8.77)	223 (8.77)	223 (8.77)	244 (9.61)	244 (9.61)	244 (9.61)	272 (10.70)	272 (10.70)	272 (10.70)
Height	H2	515 (20.28)	515 (20.28)	515 (20.28)	591 (23.27)	591 (23.27)	591 (23.27)	643 (25.31)	643 (25.31)	643 (25.31)	
Height	H3	572 (22.52)	572 (22.52)	572 (22.52)	626 (24.66)	626 (24.66)	626 (24.66)	680 (26.78)	680 (26.78)	680 (26.78)	
Remote Sensor	Maximum Height	Hr	81 (178.8)	80 (176.6)	79 (174.4)	106 (234.0)	105 (231.8)	103 (227.4)	129 (284.8)	128 (282.6)	126 (278.2)
	Approx. Weight, Unit: kg (lb) (*2)		617 (24.28)	617 (24.28)	617 (24.28)	671 (26.42)	671 (26.42)	671 (26.42)	725 (28.54)	725 (28.54)	725 (28.54)
Integral Flowmeter	Maximum Height	Hi	83 (183.2)	83 (183.2)	82 (181.0)	108 (238.4)	107 (236.2)	106 (234.0)	131 (289.2)	130 (287.0)	128 (282.6)
	Approx. Weight, Unit: kg (lb)		-	+4 (+0.16)	+4 (+0.16)	-	+4 (+0.16)	+4 (+0.16)	-	+4 (+0.16)	+4 (+0.16)
Grounding rings thin type (GRL, GRH) (*1) (*3)			-	+4 (+0.16)	+4 (+0.16)	-	+4 (+0.16)	+4 (+0.16)	-	+4 (+0.16)	+4 (+0.16)
Grounding rings thick type (GRN, GRJ) (*1) (*4)			+6 (+0.24)	+6 (+0.24)	+6 (+0.24)	+6 (+0.24)	+6 (+0.24)	+6 (+0.24)	+6 (+0.24)	+6 (+0.24)	+6 (+0.24)

- \*1: Add the value above (which is the total of both ends) to the lay length "L" when selecting optional grounding rings with/without gaskets. Also, the thickness of customer supplied gaskets should be added for getting the total lay length.
- \*2: When submersible use or optional code DHC is selected, waterproof glands with union joints and cables are attached. When the cable length is 30-meters, add 9.5 kg (20.9 lb) to the weight in the table.
- \*3: These grounding rings (GRL, GRH) are not applied to lining code F nor H but for U and D.
- \*4: When applying these grounding rings (GRN, GRJ) to lining code F or H, gaskets supplied by customer are necessary. For the sizes in this table, recommended thickness of the gasket is 3 to 5 mm (0.12 to 0.20 in.) per one, bringing 6 to 10 mm (0.24 to 0.39 in.) per two to be additionally added for getting the total lay length.
- \*5: The tolerance of the lay length "L" is as follows.
- Size 250 to 400 mm (10 to 16 in.): 0/-5 mm

**Terminal Configuration and Wiring**

**Remote Sensor:**

<To be wired to Remote Transmitter>

**Non Explosion Protection Use**

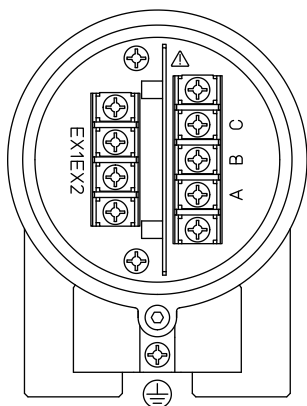

**Explosion Protection Use**

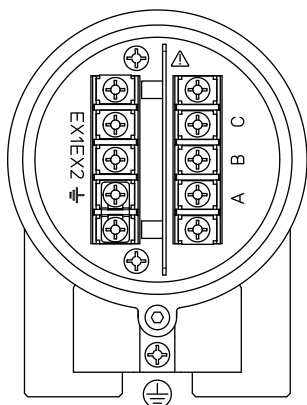

Terminal Symbol	Description
A B C	Flow Signal Output
EX1 EX2	Excitation Current Input
⊕	Protective Grounding (Outside of the terminal box)
⊖	Functional Grounding

F04.ai

Note: When submersible use or optional code DHC is selected, waterproof glands with union joints and cables are attached.

**Integral Flowmeter:**

<To be wired to Power Supply and I/Os>

**M4 Screw Type**

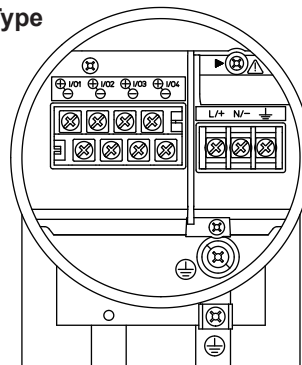

**Clamp Type**

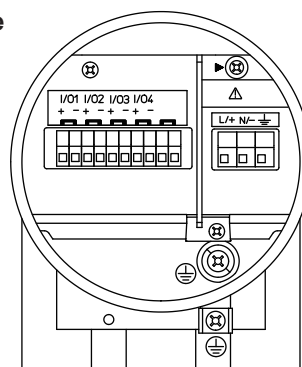

Terminal Symbol	Description
▶	Shorting Screw (Need to be fixed for normal operation)
⊖	Functional Grounding
N/- L/+	Power Supply
I/O4 - I/O4 + I/O3 - I/O3 + I/O2 - I/O2 + I/O1 - I/O1 +	Selected Input/Output
⊕	Protective Grounding (Inside and outside of the terminal box)

F05.ai