

Drawings

Model IR400 Infrared Gas Analyzer

[Style: S4]

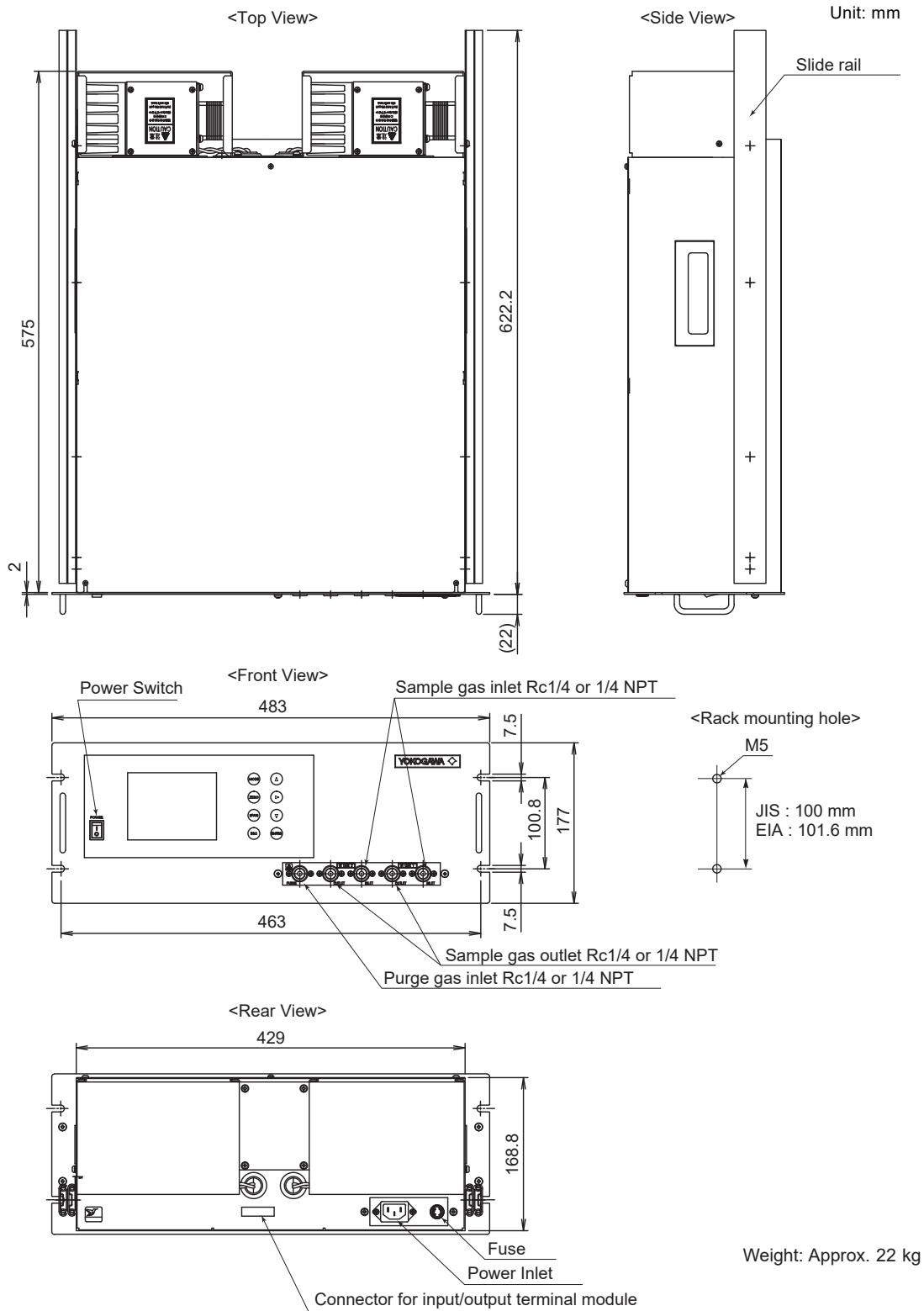

Unless otherwise specified, differences in the dimensions are specified as: General tolerance = \pm (Criteria of tolerance class IT18 in JIS B0401-1998)/2.

- **Slide Rail**
Model: equivalent to 305A-24/Accuride International Inc.

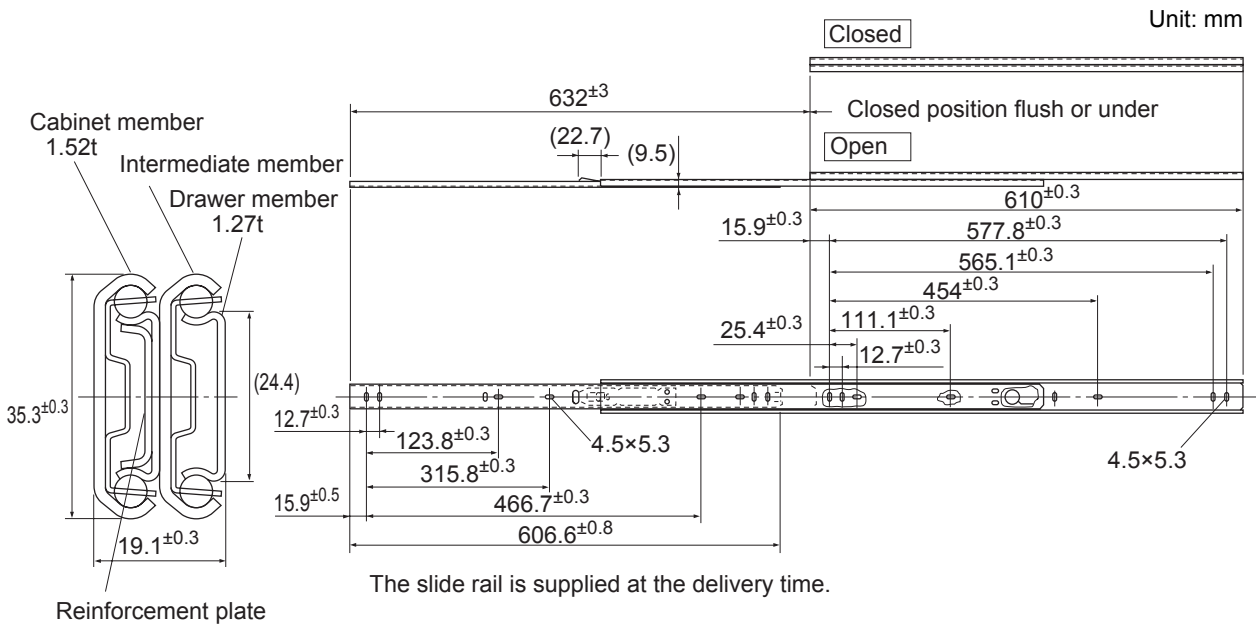

<19-inch rack mounting method>

For easy maintenance, we recommended the mounting method which allows the rack to be drawn out along the slide rail.

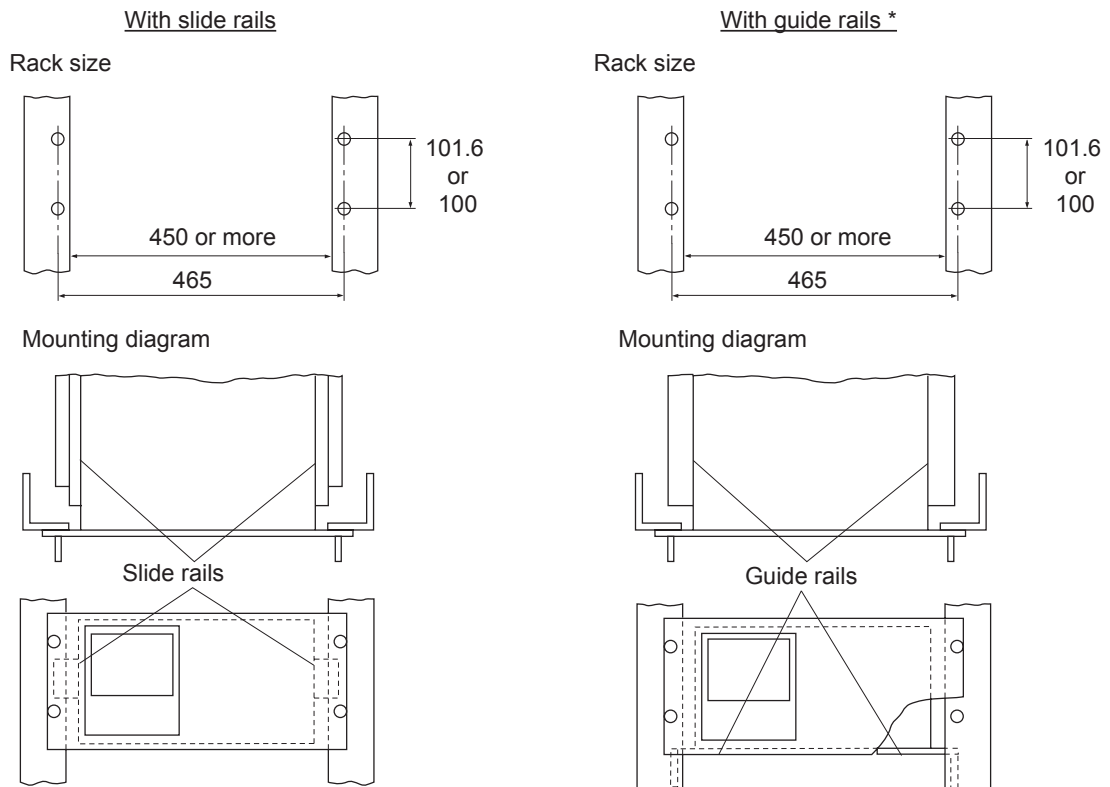

* For mounting with guide rails, a maintenance space (200 mm or more) should be provided on top of the main unit.

Unless otherwise specified, differences in the dimensions are specified as: General tolerance = \pm (Criteria of tolerance class IT18 in JIS B0401-1998)/2.

□ **Dedicated Relay Board (option code /R)**

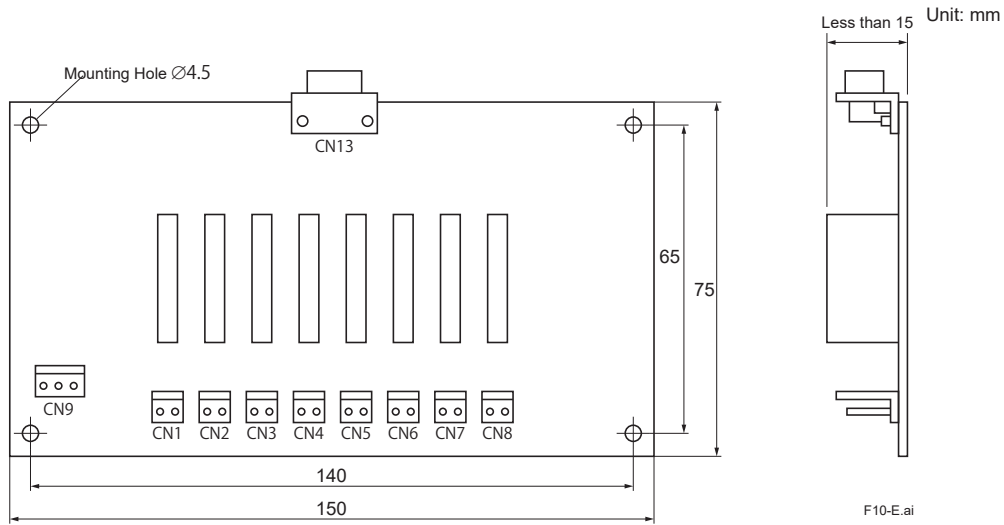

<How to connect>

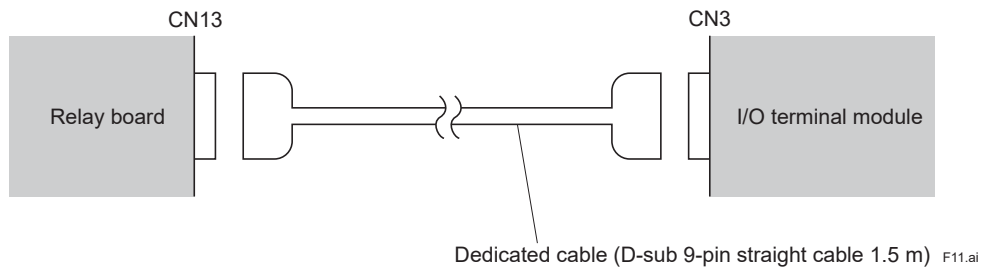
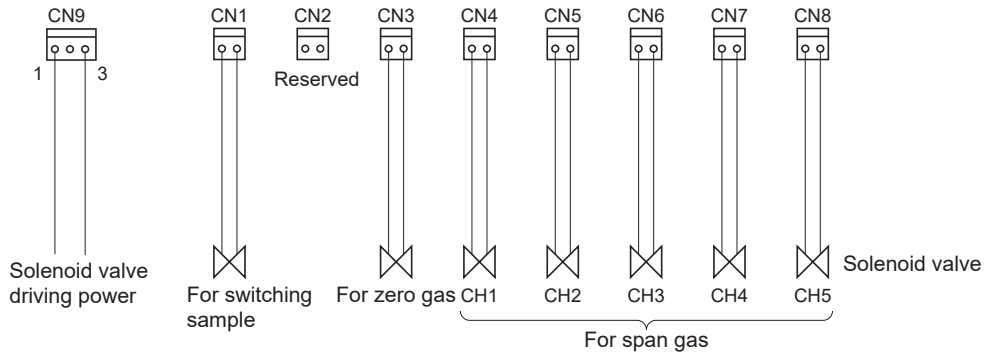

Unless otherwise specified, differences in the dimensions are specified as: General tolerance = \pm (Criteria of tolerance class IT18 in JIS B0401-1998)/2.

External Connection Diagram

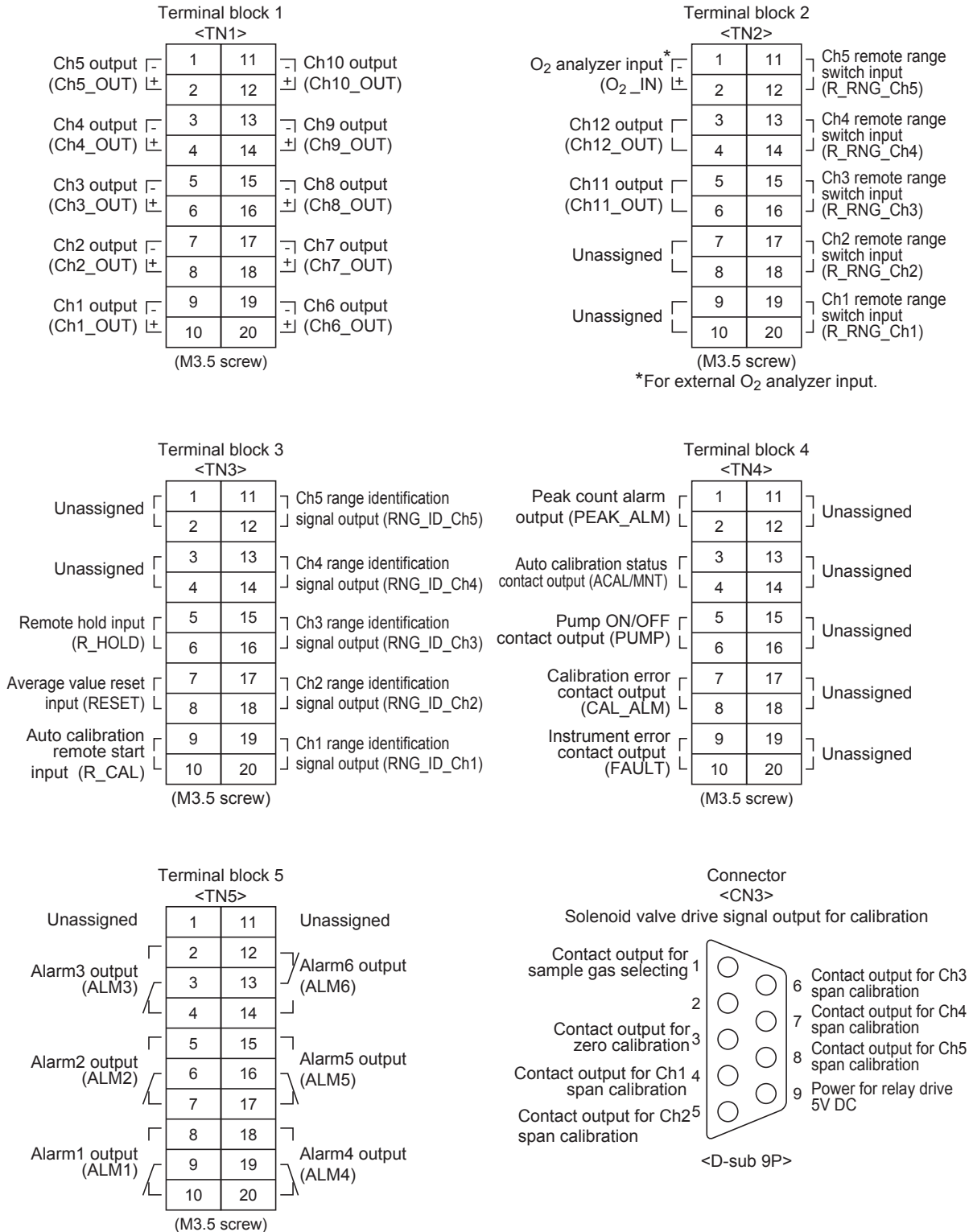

Note 1: Unassigned terminals are used for internal connection. So they should not be used as repeating terminals either.
 Note 2: The allocation of each channel (Ch1 to Ch12) depends on measured gas components. Refer to the table on the next page.

F08.ai