

# LABEL CHECKER

## LBC6XX

All-in-one solution for OCR and various labels checking task

**SICK**  
Sensor Intelligence.



---

<b>Described Product</b>	Label Checker LBC6XX
<b>Document Identification</b>	Operating instruction for Label Checker 8024172/1CMX 3.0 2021-06-28
<b>Manufacturer</b>	SICK AG Erwin-SICK-Str. 1 · 79183 Waldkirch · Deutschland www.sick.com
<b>Manufacturing Location</b>	SICK AG Gisela-SICK-Str. 1 · 79276 Reute · Deutschland
<b>Trademarks</b>	Windows is a registered trademark Microsoft Corporation. Halcon is a registered trademark of MVTec Software GmbH.
<b>Original Documents</b>	The english issue 8024172/1CMX of this document is an original document of the SICK AG.  SICK AG does not accept responsibility for the correctness of any unauthorized translations of this document.  If in doubt, contact SICK or your local representative.
<b>Legal Notices</b>	Subject to change without prior notice.  © SICK AG. All rights reserved



## Contents

<b>1</b>	<b>About this document.....</b>	<b>8</b>
1.1	Information on the operating instructions.....	8
1.2	Scope.....	8
1.3	Explanation of symbols.....	9
1.4	Further information.....	10
1.5	Customer service.....	10
<b>2</b>	<b>Safety.....</b>	<b>11</b>
2.1	General safety notes.....	11
2.2	Intended use.....	11
2.3	Requirements for the qualification of personnel.....	12
<b>3</b>	<b>Installation.....</b>	<b>13</b>
3.1	Scope of delivery.....	13
3.2	System requirements.....	13
3.3	Hardware.....	13
3.3.1	Module components examples.....	14
3.3.2	Mounting and reflection prevention.....	25
3.4	Electrical installation.....	19
3.4.1	LBC621 connections pin assignment.....	19
3.4.2	LBC63x connections pin assignment.....	21
3.4.3	LBCP64x/65x connections pin assignment.....	23
<b>4</b>	<b>Getting started.....</b>	<b>25</b>
4.1	User interface at a glance.....	26
4.2	Login.....	28
4.3	Status results.....	30
4.4	Inspection result.....	31
4.5	Run tab.....	32
4.5.1	Create new job.....	33
4.5.2	Rename.....	33
4.5.3	Remove.....	33
4.5.4	Copy selected job.....	33
4.5.5	Reset total counters.....	34
4.5.6	Select inspection to set expected text.....	34
4.5.7	Set expected text.....	34
4.5.8	Inspection trigger.....	34
4.5.9	How to create a job program.....	35
4.5.10	Renaming a job program.....	35
4.5.11	How to remove a job program.....	35

# CONTENTS

---

4.5.12	How to copy a selected job.....	36
4.5.13	Failed inspection - image process.....	37
4.6	Image tab.....	38
4.6.1	Save reference image.....	38
4.6.2	List of available jobs.....	38
4.6.3	Save Image to File.....	39
4.6.4	Image settings.....	40
4.6.5	Preprocessing filter.....	41
4.6.6	How to adjust and save the reference image.....	42
4.6.7	How to perform picture calibration/rectification.....	46
4.7	Object locator.....	53
4.7.1	Object locator region.....	54
4.7.2	Mask region.....	58
4.7.3	Search area region.....	58
4.7.4	Region shape.....	58
4.7.5	How to adjust the object locator regions.....	59
4.7.6	How to create the Object locator.....	65
4.7.7	Mask region.....	69
4.7.8	How to remove a region in the Object locator.....	70
4.8	OCR/OCV tab.....	71
4.8.1	Add OCR/OCV region.....	72
4.8.2	Region shape.....	72
4.8.3	Print type.....	72
4.8.4	Thresholding method.....	73
4.8.5	Maximum mismatch.....	74
4.8.6	Specify number of characters.....	74
4.8.7	CRC (Cyclic Redundancy Check).....	75
4.8.8	Font.....	75
4.8.9	Character type.....	77
4.8.10	Minimum confidence.....	78
4.8.11	Reading type.....	78
4.8.12	Expected text counter.....	78
4.8.13	Types of image filter.....	79
4.8.14	How to manage the image filters.....	82
4.8.15	How to utilize each image filter.....	84
4.8.16	How to teach the OCR/OCV region.....	88
4.8.17	How to select and adjust each type of Character segmentation.....	94
4.9	1D code.....	104
4.9.1	1D code types.....	104
4.9.2	Inverted.....	104
4.9.3	Specify number of characters.....	105
4.9.4	Quality check.....	105
4.9.5	1D code reading type.....	105
4.9.6	Expected text change.....	106



4.9.7	1D code expected text.....	106
4.9.8	How to read 1D code .....	107
4.10	2D code.....	110
4.10.1	2D code type .....	110
4.10.2	Dot peening.....	111
4.10.3	Inverted.....	111
4.10.4	Specific number of characters.....	111
4.10.5	Quality check.....	111
4.10.6	2D code reading type.....	112
4.10.7	Expected text change.....	112
4.10.8	2D code expected text.....	112
4.10.9	How to create 2D code .....	113
4.11	Other inspections .....	116
4.11.1	Pixel counter.....	117
4.11.2	2D measurement.....	120
4.11.3	Pattern verifier.....	126
4.11.4	Blob.....	130
4.12	FTP setup.....	134
4.12.1	FTP client settings.....	134
4.12.2	How to save results.....	136
4.12.3	Draw results to image.....	136
4.12.4	Save results to file. csv file.....	136
4.12.5	IP address.....	137
4.12.6	Port.....	137
4.12.7	Username .....	137
4.12.8	Password .....	137
4.13	Digital Inputs/ Outputs.....	138
4.13.1	Apply.....	138
4.13.2	Start inspection trigger settings .....	139
4.13.3	Output settings.....	140
4.13.4	Light settings.....	143
4.13.5	How to set up the Input/Output settings.....	144
4.13.6	DI/DO for LBC621/LBC63x/LBC64x/LBC65x.....	146
4.14	Font teaching.....	146
4.14.1	Create/ modify new/existing alphabets.....	147
4.14.2	Font teaching settings.....	147
4.14.3	How to create font teaching.....	147
4.15	Communication.....	151
4.15.1	Command list.....	153
4.15.2	UDP, TCP/IP and serial .....	155
4.15.3	PROFINET.....	159
4.15.4	Ethernet/IP.....	163
4.15.5	PROFINET and Ethernet /IP Control bits behavior.....	166
4.15.6	LBC621 supported communication interfaces .....	174

4.15.7	LBC63x/64x/65x supported communication interfaces.....	174
4.15.8	CDBF600 module setup.....	175
4.16	Output format.....	177
4.17	Camera simulator.....	185
4.17.1	How to work with the camera simulator.....	185
4.17.2	How to use the camera emulator in the AppStudio and run the LBC app.....	189
4.18	Statistics.....	192
4.19	System settings.....	193
4.19.1	Camera.....	193
4.19.2	Inspections.....	193
4.19.3	Visualization.....	194
4.19.4	Time settings.....	195
4.19.5	Save images on SD card.....	196
4.19.6	Synchronize camera time with PC.....	197
4.19.7	SD card backup cloning.....	199
<b>5</b>	<b>LBC Software.....</b>	<b>200</b>
5.1	Software installation.....	200
5.2	Software update procedure and handling license file.....	201
5.3	Backup transfer to another camera and to HDD.....	209
5.4	Backup transfer between different versions of Software and Firmware/different camera types.....	212
<b>6</b>	<b>Troubleshooting.....</b>	<b>216</b>
6.1	Overview of possible faults & error.....	216
6.2	Detailed fault analysis.....	216
6.3	Resetting to factory mode.....	217
6.4	Beep description.....	217
6.5	Ready LED status description.....	218
6.6	Returning devices.....	219
6.7	SICK Support.....	219
<b>7</b>	<b>Appendices.....</b>	<b>220</b>
7.1	Optic filters.....	220
7.1.1	Polarizing filter.....	220
7.1.2	IR filter.....	221
7.1.3	Polarizing and IR filters benefits, image performance tuning....	221
7.1.4	Polarizing filter influence on the camera image brightness.....	222
7.1.5	IR filter influence on the camera image.....	223
7.1.6	Polarizing and IR filters (example components).....	225
7.2	Power cable wiring.....	229
7.3	CDB650 connections pin assignment.....	229
7.4	ICL300 connections pin assignment.....	230
7.5	Encoder DFS60B-S1PA10000 pinout.....	231

7.6	Trigger and external illumination connection.....	233
7.7	Encoder connection (directly or via CDB650).....	233
7.8	LBC621 accessories.....	234
7.9	Illumination color influence.....	235
7.10	Technical data.....	236
7.11	Additional accessories.....	239
7.12	Ordering information.....	239

# 1 ABOUT THIS DOCUMENT

---

## 1 About this document

### 1.1 Information on the operating instructions

These operating instructions provide important information on how to use devices from SICK AG.

Prerequisites for safe work are:

- Compliance with all safety notes and handling instructions supplied.
- Compliance with local work safety regulations and general safety regulations for device applications

The operating instructions are intended to be used by qualified personnel and electrical specialists.



---

Read these operating instructions carefully before starting any work on the device, in order to familiarize yourself with the device and its functions.

---

The instructions constitute an integral part of the product, which must be stored immediate near the device, so they remain accessible to staff at all times. Should the device be passed on to a third party, these operating instructions should be handed over with it. These operating instructions do not provide information on operating the machine in which the device is integrated. For further information, refer to the operating instructions of the particular machine.

### 1.2 Scope

These operating instructions serve to incorporate the device into a customer system. Instructions are given by stages for all actions required. These instructions apply to all available device variants of the product.



More detailed information of available device type and variants is listed on the on-line product page:

- ▶ <https://www.sick.com/cz/en/machine-vision/2d-machine-vision/inspectorp62x/c/g507066>
- ▶ <https://www.sick.com/cz/en/machine-vision/2d-machine-vision/inspectorp63x/c/g401751>
- ▶ <https://www.sick.com/cz/en/machine-vision/2d-machine-vision/inspectorp64x/c/g401752>
- ▶ <https://www.sick.com/cz/en/machine-vision/2d-machine-vision/inspectorp65x/c/g401753>

Various device variants are used as examples for commissioning, based on the default parameter settings for the relevant device.

### 1.3 Explanation of symbols

Warnings and important information in this document are labeled with symbols. The warnings are introduced with signal words that indicate the extent of the danger, these warnings must be observed at all times. Care must be taken to avoid accidents, personal injury, and material damage.



---

**DANGER**

... Indicates a situation of imminent danger, which will lead to a fatality or serious injuries if not prevented.

---



---

**WARNING**

... Indicates a potentially dangerous situation, which may lead to a fatality or serious injuries if not prevented.

---



---

**CAUTION**

... Indicates a potentially dangerous situation, which may lead to minor/slight injuries if not prevented.

---



---

**NOTICE**

... Indicates a potentially harmful situation, which may lead to material damage if not prevented.

---



---

**NOTE**

... Highlights useful tips and recommendations as well as information for efficient and trouble-free operation.

---



---

**REFERENCE**

Used to refer to other parts of these operating instructions or an external document.

---

**Instructions to actions**

- ▶ The arrow denotes instructions to action.
- 1. The sequence of instructions for action is numbered.
- 2. Follow the order in which the numbered instructions are given.

# 1 ABOUT THIS DOCUMENT

---

## 1.4 Further information



---

All the documentation available for the device can be found on the on-line product page at:

- ▶ [www.sick.com](http://www.sick.com)

The following information is available for download:

- Model-specific on-line data sheets for device variants, containing technical data, dimensional drawings, and diagrams.
  - EU declaration of conformity for the product family.
  - Dimensional drawings and 3D CAD dimension models in various electronic formats.
  - These operating instructions, available in English and German, and in other languages if necessary.
  - Other publications related to the devices described here.
  - Publications dealing with accessories.
- 

## 1.5 Customer service

If you require any technical information, our customer service department will be happy to help. To find your representative, see the final page of this document.



---

Before calling, make a note of all type label data such as type code, serial number, etc. to ensure faster processing.

---

## 2 Safety

### 2.1 General safety notes

This chapter contains general safety information about the Label Checker.

Further information about specific product use/situations can be found in the relevant chapters.

Additional safety information about configured devices can be found in the operating instructions for the relevant devices.

Please refer to [Chapter 1.2 Scope](#).



#### **Hazard due to lack of effectiveness of the protective device**

If there is non-compliance, it is possible that the dangerous state of the machine may not be stopped or not stopped in a timely manner.

- ▶ Please read this document carefully and make sure that you understand the content fully before working with the device.
  - ▶ Follow all safety notes in this document.
- 

### 2.2 Intended use

The Label Checker can be used to design, configure, commission, and diagnose safety-related devices or system configurations.

### 2.3 Requirements for the qualification of personnel

Only qualified Service personnel may use the Label Checker to design, configure, commission, and diagnose safety-related devices, device groups, or system configurations.

#### **Project planning**

For project planning, a person is considered competent when he/she has expertise and experience in the selection and use of protective devices on machines and is familiar with the relevant technical rules and national work safety regulations.

#### **Parameterization**

For parameterization, a person is considered competent when he/she has the expertise and experience in the relevant field and is sufficiently familiar with the application of the protective device on the machine that he/she can assess its work safety aspects.

#### **Commissioning**

For commissioning, a person is considered competent when he/she has the expertise and experience in the relevant field and is sufficiently familiar with the application of the protective device on the machine that he/she can assess its operational safety status.

#### **Operation and maintenance**

For operation and maintenance, a person is considered competent when he/she has the expertise and experience in the relevant field and is sufficiently familiar with the application of the protective device on the machine and has been instructed by the machine operator in its operation.



## 3 Installation

### 3.1 Scope of delivery

Depending on the device version and the accessories ordered, the scope of delivery will include the listed items:

- Label Checker (InspectorP6xx Flex + LBC App preinstalled).
- Software (Installed)
- Two sliding nuts, M5
- Light inlet and electrical connections fitted with protective caps/plugs.
- SW 2 hexagon key for opening and closing the micro SD card slot cover and mounting the integrable illumination unit from the optic kit (InspectorP6xx Flex)

#### Accessories

Accessories such as the optic kit, brackets, connecting cables and SD card are only supplied if ordered separately.

### 3.2 System requirements

#### Operator interface:

- Supported Web Browsers: Google Chrome: 69.0.3497.92, Mozilla Firefox: 62.0.2 (32-bit) and Internet Explorer 11.0.969919129 or the most recent version.
- SOPASair uses new web technologies such as HTML5, so technical incompatibilities can be expected when using older browsers.

### 3.3 Hardware

The Label Checker is based on InspectorPxx camera, for further mechanical and electrical information.



Please refer to:

- ▶ <https://www.sick.com/cz/en/machine-vision/2d-machine-vision/inspectorp62x/c/g507066>
- ▶ <https://www.sick.com/cz/en/machine-vision/2d-machine-vision/inspectorp63x/c/g401751>
- ▶ <https://www.sick.com/cz/en/machine-vision/2d-machine-vision/inspectorp64x/c/g401752>
- ▶ <https://www.sick.com/cz/en/machine-vision/2d-machine-vision/inspectorp65x/c/g401753>

## 3 INSTALLATION

### 3.3.1 Module components examples



Label Checker already support PROFINET onboard and CDF module is needed in special occasions only. Please be informed that the LBC62x will not support Profinet until 2021.

The following setup displays a variety of Label Checker connections:

#### LBC621

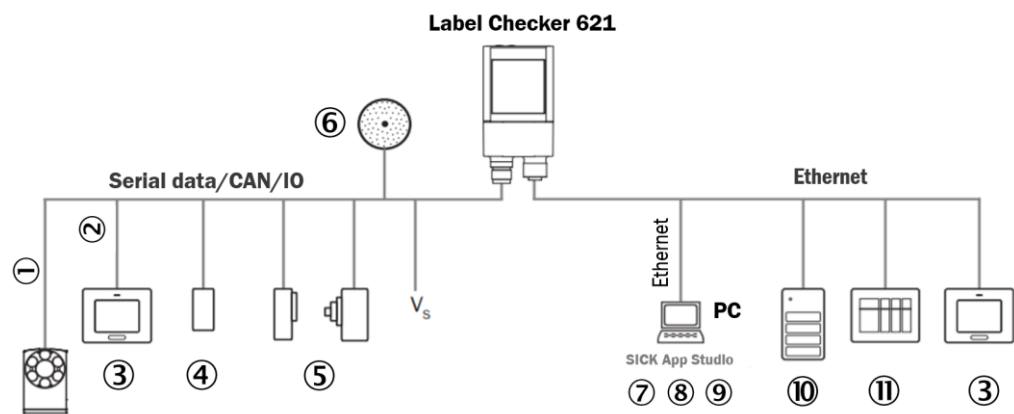

Figure 1 Label Checker 621 connections

#### Description:

- |  |                              |
|--|------------------------------|
| ① CSN/CAN (not supported)  | ⑦ Setting                    |
| ② Serial   | ⑧ Image display              |
| ③ PLC (Programmable Logic Controller)                                      | ⑨ Diagnostics                |
| ④ Digital Outputs e.g. signal lamps  | ⑩ FTP server (image storage) |
| ⑤ Digital inputs e.g. for encoders, photoelectric sensors (trigger sensor) | ⑪ HMI interface              |
| ⑥ External illumination unit, e. g. ICL                                    |                              |

**Label Checker connection examples**

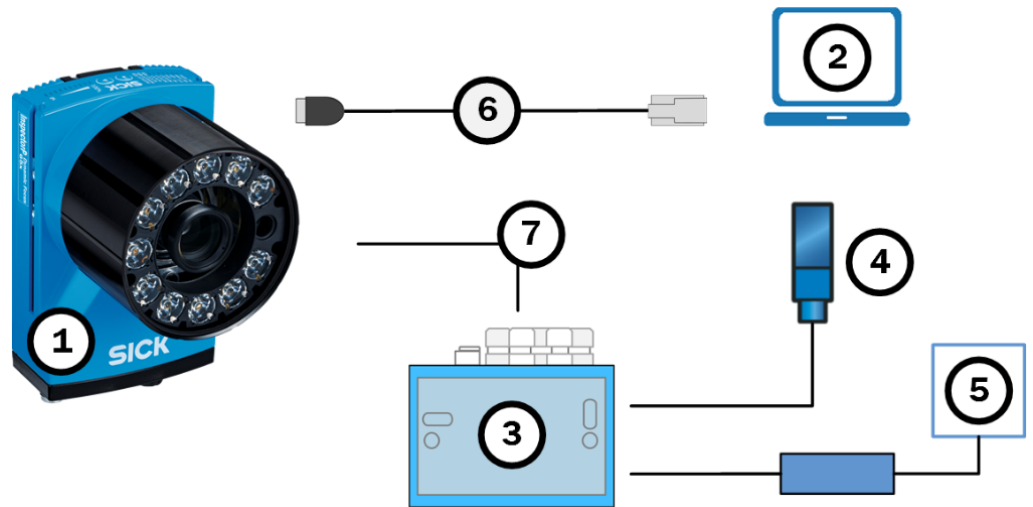

Figure 2 LBC6xx connected via module CDB650-204

**Description:**

- ① Label Checker camera
- ② PC
- ③ Connection module CDB650-204
- ④ Trigger sensor
- ⑤ voltage supply 24V DC
- ⑥ Ethernet cable M12, 8-pin, x-coded
- ⑦ Power I/O cable M-12, 17-pin, A-coded

### 3 INSTALLATION

---

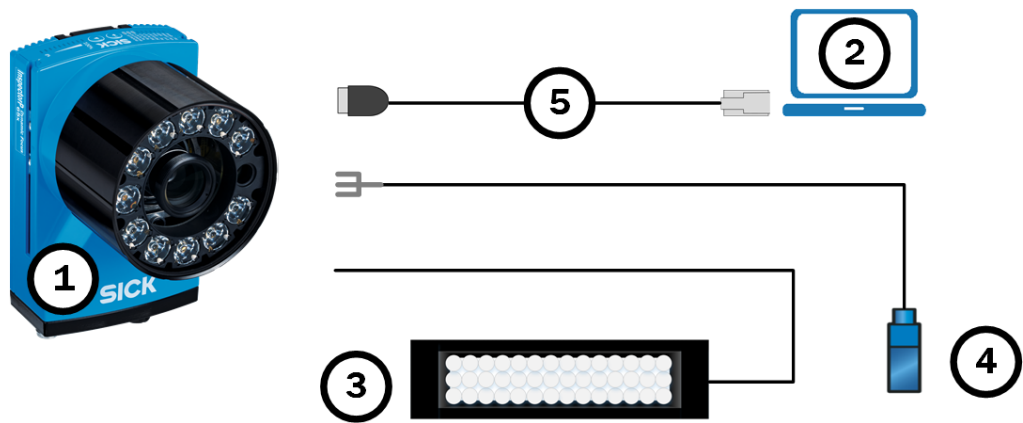

Figure 3 LBC6xx using external illumination and trigger sensor.

#### Description:

- |                         |                                      |
|-------------------------|--------------------------------------|
| ① Label Checker camera  | ④ Trigger sensor                     |
| ② PC                    | ⑤ Ethernet cable M12, 8-pin, x-coded |
| ③ External Illumination |                                      |



Figure 4 LBC65x and LBC642 using external illumination

**Description:**

- |                        |                                      |
|------------------------|--------------------------------------|
| ① Label Checker camera | ⑤ PC                                 |
| ② C-mount lens         | ⑥ External illumination              |
| ③ Lens protective hood | ⑦ Ethernet cable M12, 8-pin, x-coded |
| ④ Mounting brackets    | ⑧ Connecting cable                   |

### 3 INSTALLATION

---

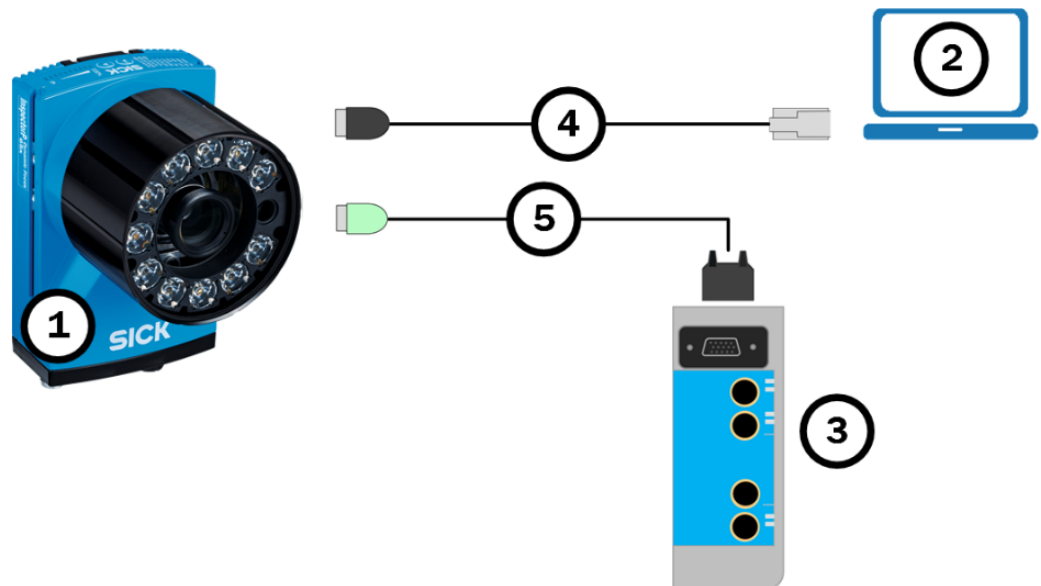

Figure 5 LBC6xx connected via CDF600 module

**Description:**

- ① Label Checker camera
- ② PC
- ③ PROFINET CDF600-2200
- ④ Ethernet cable M12, 8 – pin, x-coded
- ⑤ Connection cable 2m

3.4 Electrical installation

3.4.1 LBC621 connections pin assignment

**Power/serial data/CAN/I/O connection**

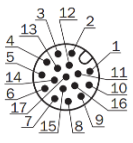
Pin	Signal	Function
		
1	GND	Ground
2	V <sub>s</sub>	Supply voltage
3	CAN L	CAN bus (IN/OUT)
4	CAN H	CAN bus (IN/OUT)
5	TD+ (RS-422/485), host	Host interface (sender+)
6	TD- (RS-422/485), host TxD (RS-232), host	Host interface (sender-)
7	TxD (RS-232), AUX	AUX interface (sender)
8	RxD (RS-232), AUX	AUX interface (receiver)
9	SensGND	Digital input ground
10	Sensor 1	Digital input 1
11	RD+ (RS-422/485), host	Host interface (receiver+)
12	RD- (RS-422/485), host RxD (RS-232), host	Host interface (receiver-)
13	IN/OUT 3	Digital input/Digital output 3 (configurable)
14	IN/OUT 4	Digital input/Digital output 4 (configurable)
15	Sensor 2	Digital input 2
16	IN/OUT 5	Digital input/Digital output 5 (configurable)
17	IN/OUT 6	Digital input/Digital output 6 (configurable)
-	-	Shield

### 3 INSTALLATION

---

#### LBC621 Ethernet connection

Pin	Signal	Function
1	TD+	Sender+
2	RD+	Receiver+
3	TD-	Sender-
4	RD-	Receiver-

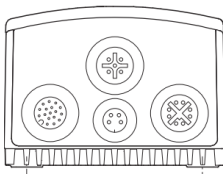
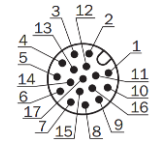
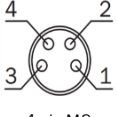
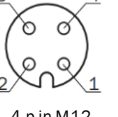
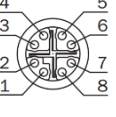

3.4.2 LBC63x connections pin assignment

Pin	Power/ Serial Data/CAN/IO	USB <sup>1</sup>	External Illumination connection	GB Ethernet
	 17-pin M12 male connector, A-coded	 4-pin M8 female connector	 4-p in M12 female connector, A-coded	 8-pin M12 female connector, X-coded
1	GND	N/C	DC 24-V switchable output	TRDO_P
2	DC 24 V ± 20%	N/C	Trigger illumination DC 24 V	TRDO_N
3	CAN L	N/C	GND	TRD1_P
4	CAN H	N/C	Not connected	TRD1_N
5	TD+(RS-422), Host	-	-	TRD3_P
6	TD- (RS-422), Host TxD (RS-232), Host	-	-	TRD3_N
7	TxD (RS-232), AUX	-	-	TRD2_P
8	RxD (RS-232), AUX	-	-	TRD2_N
9	SensGND	-	-	-
10	Sensor 1 switching Input	-	-	-



### 3 INSTALLATION

---

11	RD+ (RS-422), Host	-	-	-
12	RD- (RS-422), Host RxD (RS-232), Host	-	-	-
13	IN/OUT 3, configurable	-	-	-
14	IN/OUT 4, configurable	-	-	-
15	Sensor 2 switching input	-	-	-
16	IN/OUT 5, configurable	-	-	-
17	IN/OUT 6, configurable	-	-	-

Table 1 Label Checker 63x

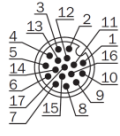
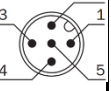
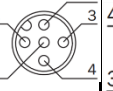
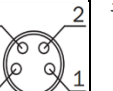
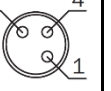
3.4.3 LBCP64x/65x connections pin assignment

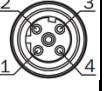
Pin	Power/ Serial Data/CAN/ IO	CAN IN <sup>1</sup>	CAN OUT <sup>1</sup>	USB <sup>1</sup>	Triggering of external Illumination	GB Ethernet	Ethernet <sup>1</sup>
	 17-pin M12 male connector, A-coded	 5-pin M12 male connector, A-coded	 5-pin M12 female connector, A-coded	 4-pin M8 female connector	 3-pin M8 female connector	 8-pin M12 female connector, X-coded	 4-pin M12 female connector, D-coded
1	GND	Shield	Shield	N/C	Sensor 1	TRD0_P	-
2	DC 24 V ± 20%	DC 24 V ± 20%	DC 24 V ± 20%	N/C	-	TRD0_N	-
3	CAN L	GND		N/C	Result 4	TRD1_P	-
4	CAN H	CAN H	CAN H	N/C	SensGND	TRD1_N	-
5	TD+(RS-422), Host	CAN L	CAN L	-	-	TRD3_P	-
6	TD- (RS-422), Host TxD (RS-232), Host	-	-	-	-	TRD3_N	-
7	TxD (RS-232), AUX	-	-	-	-	TRD2_P	-
8	RxD (RS-232), AUX	-	-	-	-	TRD2_N	-
9	SensGND	-	-	-	-	-	-
10	Sensor 1 switching Input	-	-	-	-	-	-
11	RD+ (RS-422), Host	-	-	-	-	-	-
12	RD- (RS-422), Host RxD (RS-232), Host	-	-	-	-	-	-
13	Result 1 switching output	-	-	-	-	-	-

### 3 INSTALLATION

---

14	Result 2 switching output	-	-	-	-	-	-
15	Sensor 2 switching input	-	-	-	-	-	-
16	Result 3 switching output	-	-	-	-	-	-
17	Result 4 switching output	-	-	-	-	-	-

Table 2 *InspectorP65x/64x*

<sup>1</sup> Not used

### 3.5 Mounting and reflection prevention

#### LBC 65x/64x/63x/621

In order to avoid reflections from the glossy surfaces to be scanned, the device is usually tilted so it is not perpendicular to the surface, unless you want to use the effect of direct reflections. When camera is tilted, the image is slightly distorted and may result in worse performance when certain inspections are performed (i.e. Object Locator). Image rectification can be used to correct the effect of perspective distortion, please find [subsection 4.6.7 on how to perform picture calibration rectification](#). Typical values are between  $10^\circ$  and  $20^\circ$ . When using a polarizing filter, the recommended angle is  $0^\circ$ .

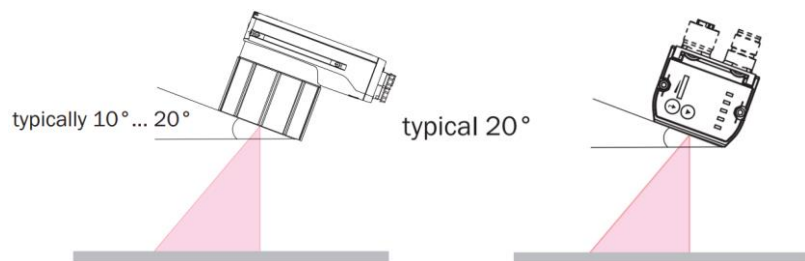

Figure 6 Typical values for LBC 65x/64x/63x/621



You may use a polarizing filter to minimize reflection effects on the image, see [subsection 7.1](#).

## 4 GETTING STARTED

### 4 Getting started

#### 4.1 User interface at a glance



Figure 7 Label Checker GUI

#### UI controls



Using this tool you can drag the polygon frame to change its position, corner/edge in order to change the size.



Select this action to grab and drag the image into a different location within the window.



Select this tool to zoom in/out images to varying levels of detail.



Home fits the image to current view.



Using the Undo/ redo functions lets you undo erroneous steps or move forward and backward through the operations.



About  
PViewer 2D  
Version:2.2.7

**Region adjustment zones**

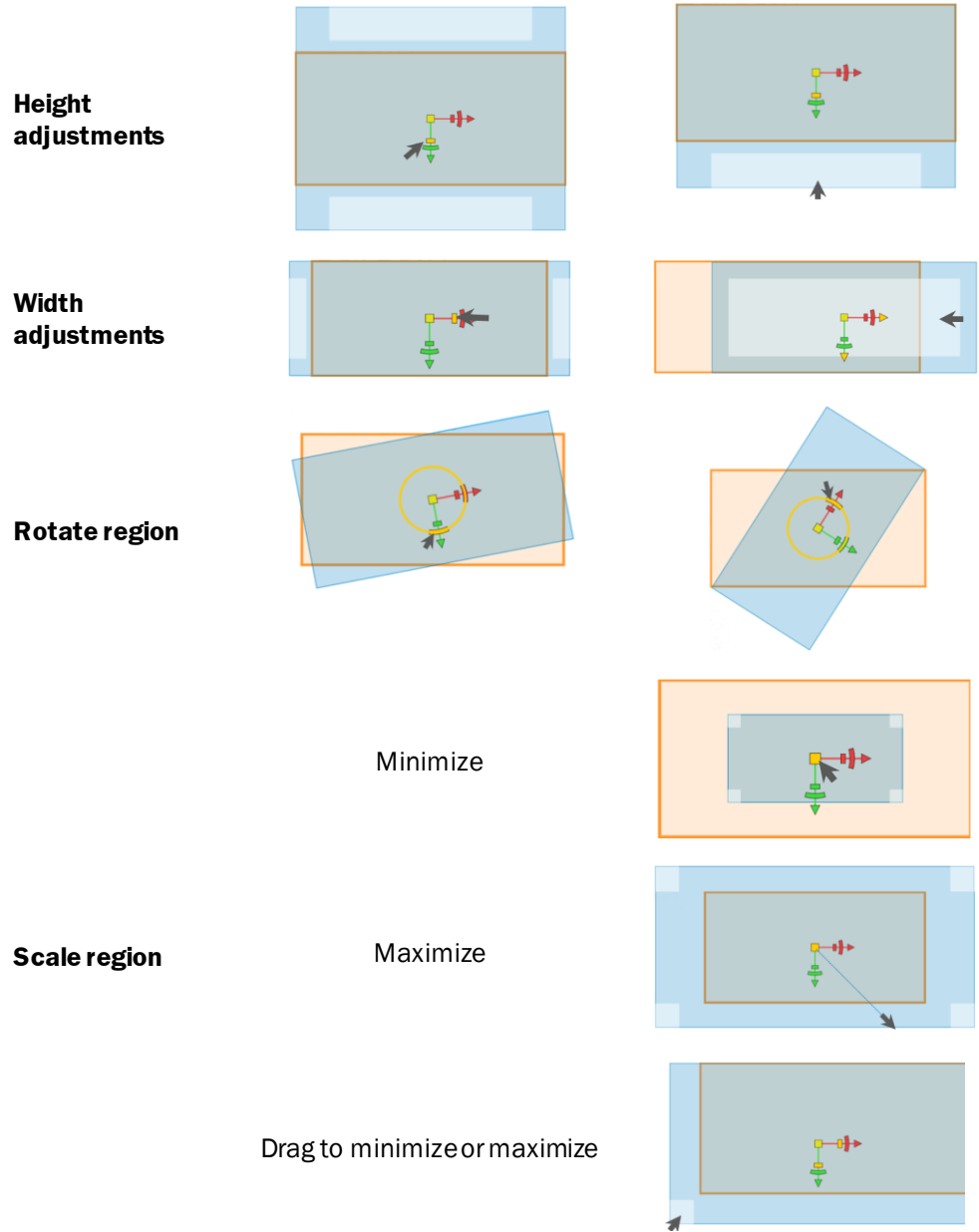

Figure 8 Region adjustments zones

## 4 GETTING STARTED

### 4.2 Login

The Label Checker will start automatically after you power up the system.



Before you start working with the program, please check if the operator screens are working properly.

The Label Checker features different types of user access levels. Each user name varies with different privileges.

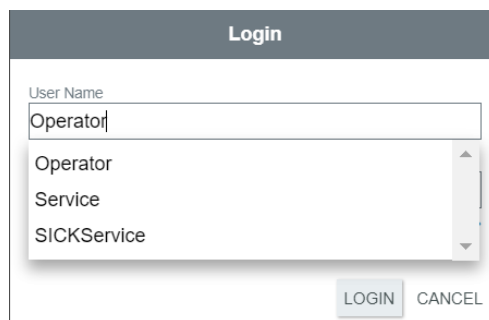

Figure 9 Login user name

#### Login and proceed as follows:

1. Type the IP address of your camera, in your web browser.



Default IP address is 192.168.0.1. The IP address of your camera can be either obtained or changed from SOPAS/AppManager. The camera must be in the same subnet as the connected PC to be visible.

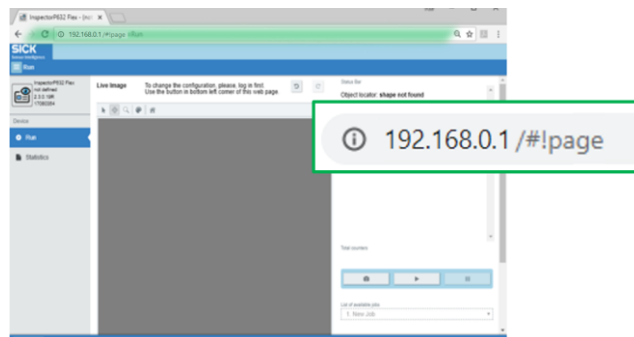

2. Click the login button , located at the bottom-left corner.



3. Enter your designated user name and password.

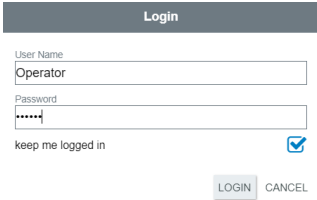

4. Afterwards, click the login button.



---

**Password:**  
Operator – No password  
Service – servicelevel

---



---

The operator has the most limited role. They can only start the system with no authority to Edit or fix any programs.

---

### 4.3 Status results

This feature will constantly display the current status of the most recently adjusted settings, which only applies to the following device tabs:



---

When the browser is refreshed, the reference image result will not appear, unless the Apply button is enabled.

---

- FTP
- Digital Inputs/Outputs
- Communication
- Output format
- Statistics
- Font teachings
- System settings

### 4.4 Inspection result

This feature will constantly display the current status of the most recently adjusted settings, which applies to the following device tabs.

- Run
- Image
- Object locator
- Total counters
- OCR/OCV
- 1D/2D codes
- Other inspections

The inspection results may be viewed via:

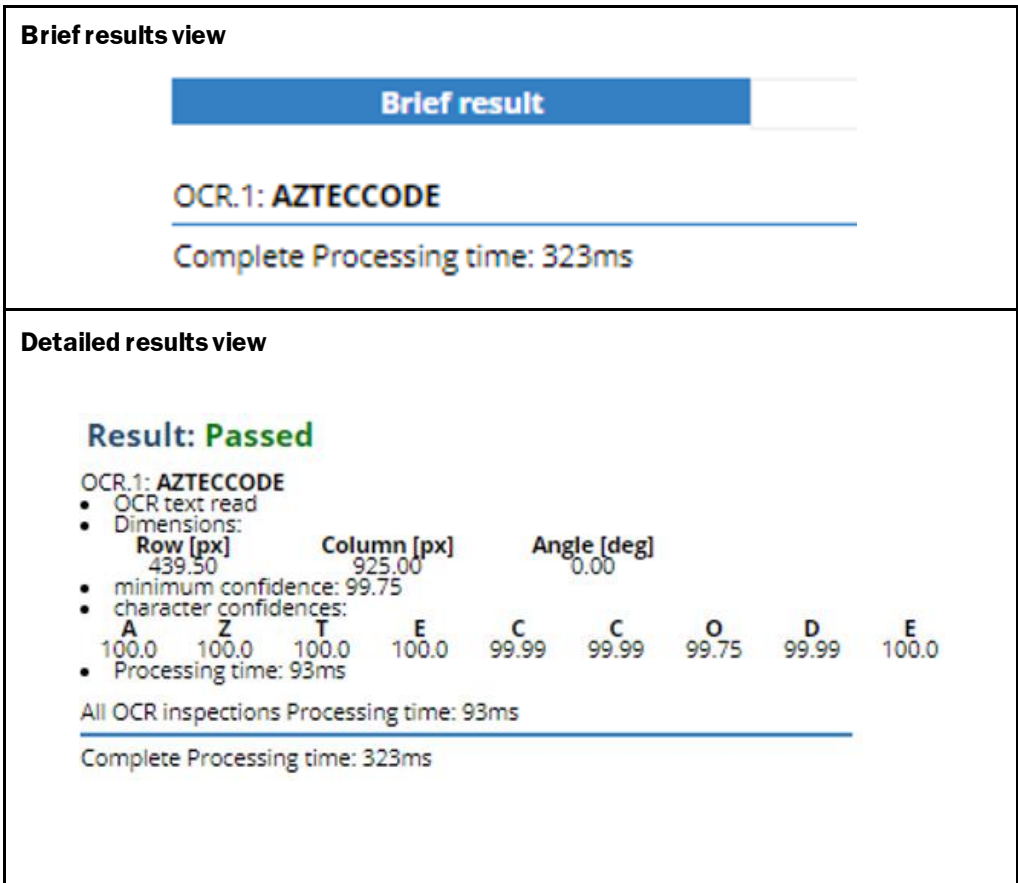

Figure 10 Inspection results

#### Job ID

Information added to the currently selected job (for better performance in combination with the “Auto job switching” function).

#### Total counters

Total counter of incoming triggers.

## 4 GETTING STARTED

---

### 4.5 Run tab

This feature allows the operating entity to create inspection, and run the created job program.

The Label Checker features different types of user access levels. Each user level varies with different privileges.

The run tab features the following settings:

- Create default job
- Rename a job
- View total counters
- List of available jobs
- Select inspection to set expected text
- View inspection results
- Process image of failed inspection
- Clear result information
- Copy a selected job
- Remove a job
- Reset total counters
- Start the program/system
- Set expected text
- Show image of failed inspection
- Inspection trigger



Service user level has full access to the Label Checker system with all permissions including maintenance, commissioning, and login privilege to restricted programs. SICK service user level is **restricted only** for SICK employees.

---



The operator has the most limited role and with no authority to Edit or fix any programs.

---



In the Run tab, the operator only has access to following features:

- Start the system.
  - Input the expected text for the already existing inspections.
-



---

Since Label Checker is web-based, some minor functionalities regarding web transfer could be automatically disabled to prevent negative influence to the speed of image processing.

The following list shows what functionalities could be automatically disabled, if there is not enough processing time (initiating from Level 1 up to Level 7):

Level 1 - Save each image and result on FTP Server

Level 2 - Save only when inspection fails

Level 3 - Save image and result on FTP Server

Level 4 - Display image to UI

Level 5 - Save reference image, store CSV data

Level 6 - Display results in UI

Level 7 - Save NOK image (Show last 30 failed images)

---

#### 4.5.1 Create new job

New job program with default parameters can be set up and saved in the camera memory by selecting Create new job.

#### 4.5.2 Rename

The operating entity can rename the job by inputting and confirming the text change/edit for the selected job.

#### 4.5.3 Remove

You can easily delete unnecessary jobs from your camera. The removed selected job will not exist in the list box, and all related files to the deleted job will be irreversibly removed from the camera memory.

#### 4.5.4 Copy selected job

Copying an existing job is a convenient way to re-use the same label sample, in order to create a different job specification.

## 4 GETTING STARTED

---

### 4.5.5 Reset total counters

You can easily reset the total counters by enabling the reset button.

Total counters provide relevant label inspection data, starting from the very first run of the Label Checker. This feature displays the OK (passed) & NOK (failed) test, including the overall passing rate for statistic purpose.

Please find [subsection 4.18 Statistics](#) to learn more about the features of the total counters.

### 4.5.6 Select inspection to set expected text

The operator (including other user levels) will be able to select the type of inspection via Run tab, in order to set/change the expected text.

### 4.5.7 Set expected text

The expected text can be inserted in this field.

### 4.5.8 Inspection trigger

Changing the inspection trigger will give you the option to quickly deactivate/activate the digital input.

#### 4.5.9 How to create a job program

##### Proceed as follows:

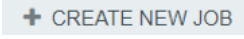
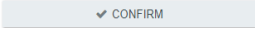
1. Select  button.
2. Type in a unique ID name for the newly created job program.
3. Then, confirm the new job program by selecting the  button.
4. Afterwards, go to image settings tab in order to save the created reference image found in [subsection 4.6 of the image tab](#)

#### 4.5.10 Renaming a job program

##### Proceed as follows:

1. Select the job program that needs to be renamed from the list of available jobs.

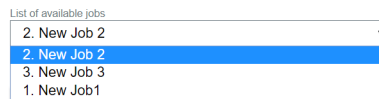

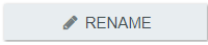
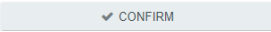
2. Then, click the  button and type in a new program name.
3. Afterwards, click the  button to verify.

#### 4.5.11 How to remove a job program

##### Proceed as follows:

1. Select the listed job that needs to be removed.

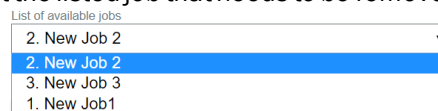

2. Then, click the  button.

3. Afterwards, a confirmation dialog box will appear.

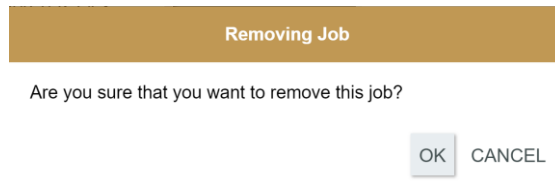

4. Click  to confirm deletion.
5. Afterwards, check the results in the Inspection result window.

### 4.5.12 How to copy a selected job

#### Proceed as follows:

1. Firstly, select the job (from the list of available job) that you would like to copy. Then click the copy selected job button.

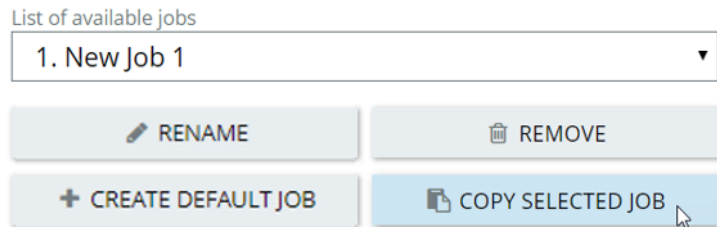

2. Fill in a new name for the selected copied job, and select the confirm button.

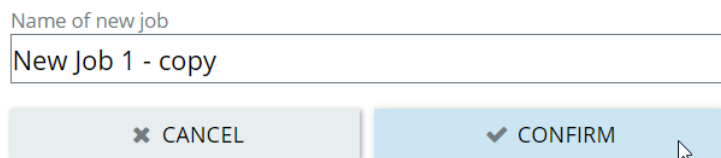



3. After confirming selection, you will find the copied job in the list of available jobs.

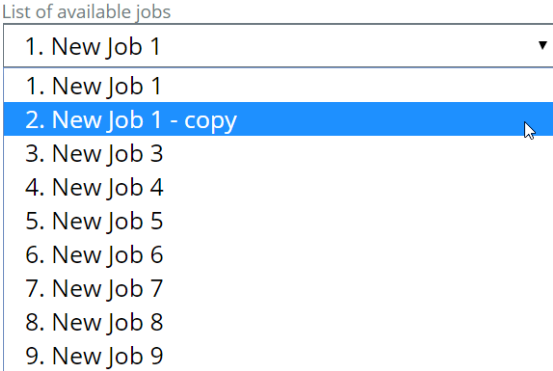

**4.5.13 Failed inspection - image process**

Provides information of at least 30 recent failed image results during production operations. The recent 30 failed images can assist in diagnosis or resolve any arising errors, and serves as ease of reference.

This feature also provides the date and time of the failed inspection.



---

Please be informed that only the last 30 recent failed images will be stored.

---

**Proceed as follows:**

1. Select one from the ten failed inspection number.

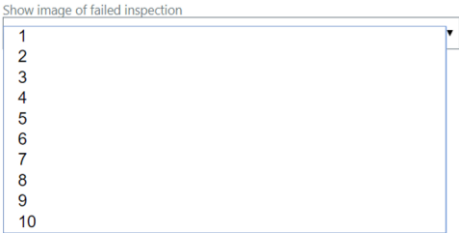

2. Then click the **PROCESS IMAGE OF FAILED INSPECTION** button.

The selected failed inspection image number with all its results will appear on the window.



---

The purpose of this feature is to select and process the selected failed inspection image in order to track why the inspection failed. You can process the last 30 failed inspection images, where number 1 is the latest failed inspection image 2 ... 30 the oldest.

---

## 4 GETTING STARTED

---

### 4.6 Image tab



---

Please be informed that you must be a “Service” level user in order to access the Image settings tab.

---



---

Reference images can ONLY be created and pre-defined via the image setting tab.

---



---

Please be informed that any changes applied will only be saved, if you have re-activated the  button.

All inspection regions will be displayed after image processing is finished with a short delay.

---

#### 4.6.1 Save reference image

When the desired exposure time and field of view requirements are achieved, the camera stores the confirmed reference image that will be used further for pre-defining the job program (label sample).

#### 4.6.2 List of available jobs

Contains the names of the pre-defined programs. The operating entity can still modify these pre-define job programs according to their requirements.

### 4.6.3 Save Image to File

When this feature is enabled, the last captured image will be stored in the camera's memory, to the path `/App data/public/camera_simulator_images/images_from_web_page/`. Saving the image can work with or without the SD card present. You may easily use the images in the camera simulator, when the camera's memory path to the images is set.

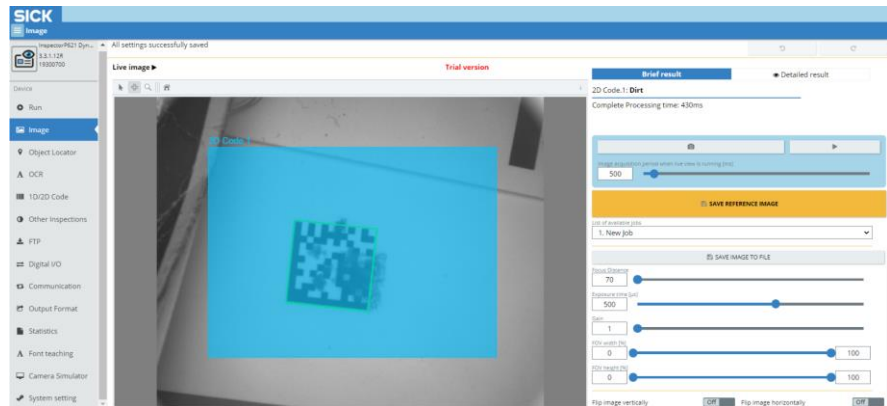

Figure 11 Last captured image stored in camera's memory

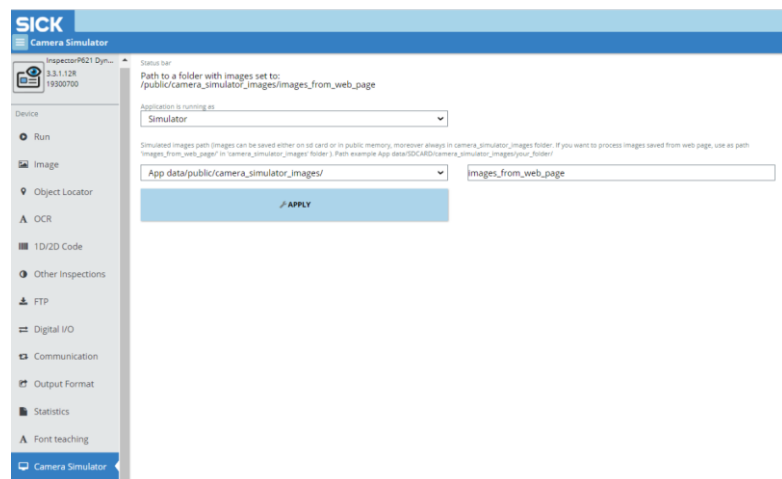

Figure 12 Camera simulator path to folder with images



Please be informed that the internal memory capacity of the camera is limited, thus we do not recommend storing large number of images (>20).

We highly recommend the use of the SD card for this purpose.

## 4 GETTING STARTED

---

### 4.6.4 Image settings

#### **Exposure time**

Exposure time is entered in microseconds and can be set from 100 microseconds to 1000 microseconds (depending on the camera type and illumination).

#### **Gain**

Gain helps brighten the image by increasing the sensitivity of the image sensor, but in tradeoff of image noise increase. Gain should only be used after optimizing the exposure settings.

#### **FOV width (maximum – minimum)**

This slider will extend or reduce your specified FOV width. You can adjust the FOV width using the slider or track bar.

#### **FOV height (maximum – minimum)**

This slider will extend or reduce your specified FOV height. You can adjust the FOV height using the slider or track bar.

#### **Flip Image horizontally**

When enabled each acquired image is flipped horizontally.

Flip Image Horizontally  Off

#### **Flip image vertically**

When enabled the acquired image is flipped vertically.

Flip Image Vertically  Off

#### 4.6.5 Preprocessing filter

Preprocessing filter modifies the image sample before any initial inspection process.



Figure 13 Preprocessing filters

##### **Minimum filter**

Selects the minimum value for each pixel from its surrounding area.

##### **Median filter**

Selects the median value for each pixel from its surrounding area.

##### **Maximum filter**

Selects the maximum value for each pixel from its surrounding area.



---

Preprocessing filters are not available for Label Checker 621.

---

## 4 GETTING STARTED

### 4.6.6 How to adjust and save the reference image



Please be informed that you must be a “Service” level user in order to access the Reference image settings.



Please be informed that any changes applied will only be saved, if you have re-activated the  button.

All inspection regions will be displayed after image processing is finished with a short delay.

#### Proceed as follows:

1. Click the continuous acquisition  button and focus the camera lens. You should be able to see the edges on the target object.
2. Set the camera or the label sample to the correct position. The target sample has to be in the center of the image.



We recommend to zoom-in the image for better focus results.



Off-center



Center position

3. When the desired image has been achieved, select the  button to stop/pause the continuous acquisition.
4. Now, adjust the Exposure time. Set the lens aperture manually, as well as the exposure time via the UI to achieve the target object with higher contrast.



We recommend overexposing the image, so the background is densely white, with no gray artifacts visible on the background (if possible).

Or underexpose the image for white characters on dark background.

Exposure and Gain affects the brightness of the image (these values are trade-off), while increasing Gain adds unwanted noise to the image, exposure time extends the time of shutter and can cause blur, if the sample is moving during image acquisition.



Please be informed that having enough illumination leads to lower value, resulting to shorter exposure time. Higher value can cause blurring, if the object is moving during exposition.

If the object is moving, we recommend using lower value, then compensate the brightness by increasing Gain.

If the exposure time is too short, the image will be underexposed, i.e. generally dark with low contrast between the part and its features.

If the exposure time is too long, then large sections of the image will appear white and washed out.

#### 5. Adjust the FOV width and FOV height.



**Unadjusted FOV**

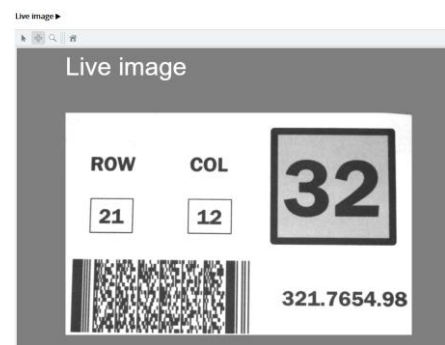

**Adjusted FOV**



We highly recommend reducing the field of view (FOV) height & width to the lowest required rate to achieve faster imaging process.

**The size of the field of view significantly affects the evaluation speed.**

#### 6. Enable these functions to change the image's orientation.

- Flip image horizontally

Flip image horizo...  Off

- Flip image vertically

Flip image vertically  Off

## 4 GETTING STARTED

7. Select the required preprocessing filters. When processing samples/objects with high reflection, then keep the exposure time low.

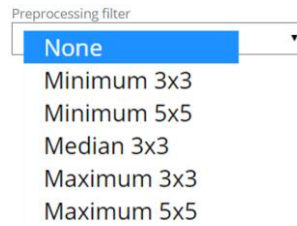

Preprocessing filters can improve the reading by adjusting the contrast or brightness of the final image. These filters are accelerated and unlike the image filters, affect the processing time insignificantly.



The ideal image adjustment for **OCR, 1D/2D**, is to overexpose the label sample (dense-white background), with no visible gray artifact.

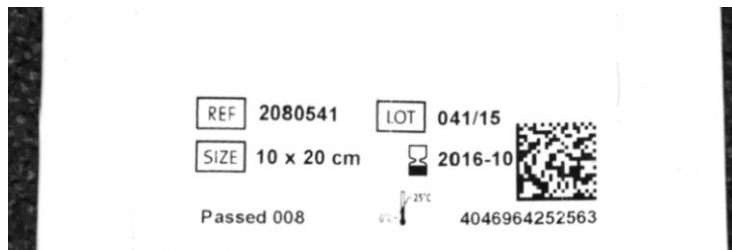

Figure 14 Overexposed image sample

Images with shades are still possible to read.



Figure 15 Under exposed image sample



Images with high reflections can produce wrong results.



Figure 16.....Images with high reflection

- When all adjusted settings are finalized, you can select the  button to store the created/edited job program.
- Then select OK to verify.

Are you sure you want to save reference image?

OK CANCEL

- Afterwards, check the results in the Inspection result window.



When the reference image is saved to the camera, it will be saved together with job settings.

## 4 GETTING STARTED

### 4.6.7 How to perform picture calibration/rectification



Please be informed that you must be a “Service” level user in order to access the Image rectification settings.



Please be informed that any changes applied will only be saved, if you have re-activated the  button.

All inspection regions will be displayed after image processing is finished with a short delay.

Image rectification flattens the image and changes the size and resolution of an acquired image. Primarily helps avoid perspective distortion effect caused by the camera (not being positioned perpendicular to the object of interest).

When the rectification map is applied onto the curved surface of the product sample, the camera will calculate the mapping between the grid points and flatten/straighten the image. These points are detected from the distorted image, including the corresponding grid points of the ideal regular point grid, thereby significantly increasing the reliability of the reference shape localization.



We highly recommend enabling the rectification setting for the following samples:

- Creased/uneven label samples
- All rounded surfaces
- Eliminate perspective distortion



Original image



Rectified image

Figure 17 Rectification process



---

It is necessary to utilize the rectification grid when performing the image rectification.

---



---

Please refer to <https://supportportal.sick.com/downloads/label-checker/> where you will be able to download the rectification grid.

---



---

Please be informed that the rectification feature has restrictions

After finalizing the rectification calibration, the products must be inspected in the same position as the product with the rectification grid.

---

**Proceed as follows:**

1. Enable the picture calibration (rectification).

Picture calibration (rectification)

On

2. Use the appropriate rectification grid size, relevant to the size of the product.
3. Apply and align the rectification grid firmly on the surface of the product sample, preferably on the desired ROI.



---

The surface to be rectified was wrapped with a rectification grid, which is used to determine the mapping between the distorted image and the rectified image.

The orientation of the two circular marks. The rectified image is rotated such that the black mark is left of the white mark.



Figure 18 Rectification grid

- 4. Set the “Distance of the grid points” parameters, to influence the resolution of the rectified image. Higher values, means higher resolution. Although, over increasing the value can significantly prolong the processing time.

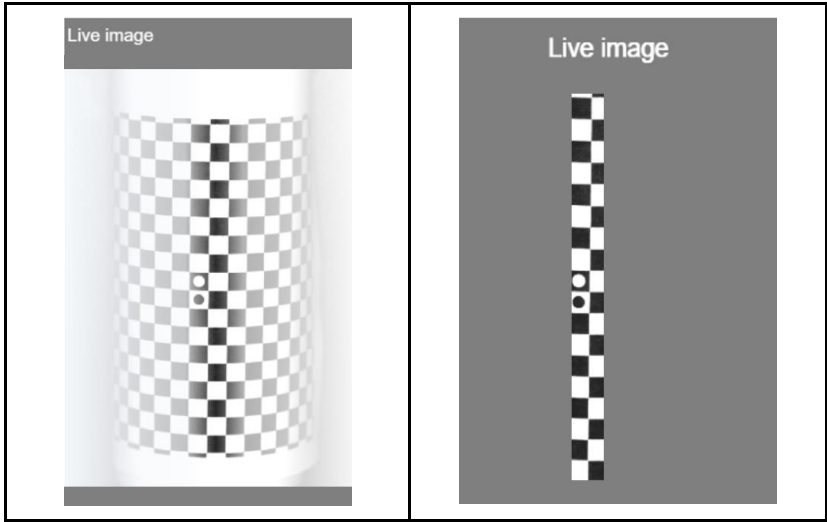

Figure 19 Overexposed image - only a contrasting part is evaluated

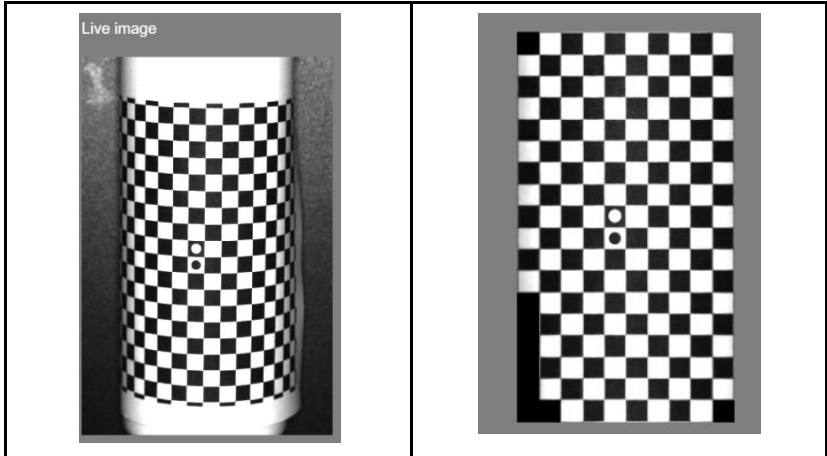

Figure 20 Optimal rectification result

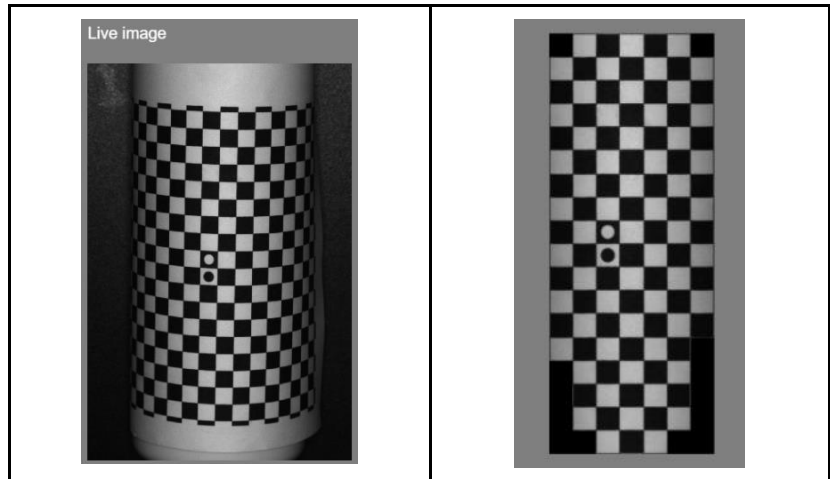

Figure 21 Underexposed image

5. Afterwards, select **CREATE CALIBRATION (RECTIFICATION) MAP**.

6. The rectification map creation process can take a few minutes.



If the rectification process is taking too long, cancel the process by clicking “restart the camera” button.

Processing... Takes too long?

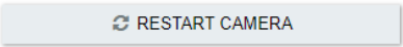
 **RESTART CAMERA**

7. When the rectification process is successful, wait for the rectifying grid to appear, and the image will be flattened accordingly.

8. You will now acquire the rectified image, and you can save it as a reference image via Image tab.

9. After creating the calibration (rectification) map and saving the reference image (via Image tab), you can remove the grid and start to create an image.

10. If the creation process fails, then you must adjust the image parameters again.



The image will not be rectified if the rectification map is not saved to the camera memory.



The image rectification has two different settings, according to user level:

Operating entity: **Service**

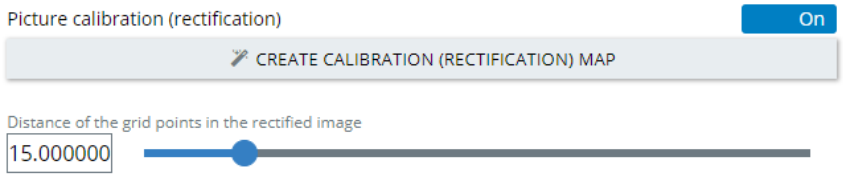

Figure 22 Operator rectification settings

- **Distance of the grid points in the rectified image**  
Influences the resolution of the rectified image. Higher values, means higher resolution.

Operating entity: **SICK service (Only available for SICK service)**

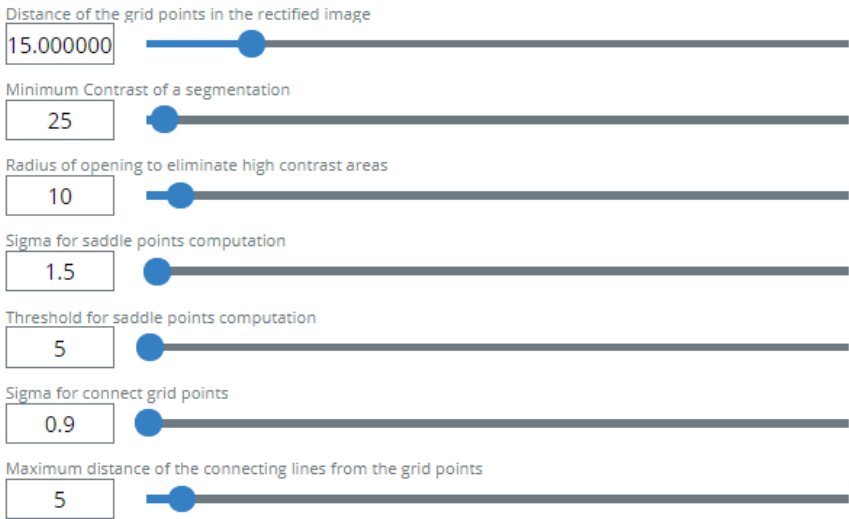

Figure 23 SICK service access to advanced rectification settings

- **Minimum Contrast of a segmentation**  
Minimum Contrast of a grid image used when segmenting the rectification grid region in the image. Image areas with a contrast of at least minimum contrast of a segmentation are extracted.
- **Radius of opening to eliminate high contrast areas**  
Radius of the circular structuring element, when segmenting the rectification grid region in the image. Image areas with a contrast of at least minimum contrast of a segmentation are extracted and the holes in these areas are filled up. Then, an opening with the radius is applied to these areas to eliminate smaller areas of high contrast.
- **Sigma Saddle Points**  
Sigma of the Gaussian to smooth an input grid image, when detecting saddle points.
- **Threshold**  
Minimum absolute value of the Eigenvalues of the Hessian matrix, when detecting saddle points in a grid image.
- **Sigma Connect Grid Points**  
Size of the applied Gaussian to smooth an input image with grid, when searching for connecting lines between the grid points (row, column) of the rectification grid.
- **Maximum distance of the connecting lines from the grid points**  
When searching for connecting lines between the grid points (row, column) of the rectification grid.



## 4.7 Object locator

When enabling the object locator tab, you will be able to teach the camera to identify a specific mark/object/shape. The object best suits as a reference. If the label moves within the field of view and reference shape is found, then the position and rotation of the regions of each inspection (OCR, code, measurement etc.) will be adjusted accordingly.

You can use this feature if the label position or rotation in front of the camera differs. Another use of this feature is to localize an object and the information of its position and rotation is required.



---

Please be informed that any changes applied will only be saved, if you have re-activated the  button.

---



---

The Object locator can highly affect the processing time. Optimizing its settings might significantly decrease influence.

---

## 4 GETTING STARTED

### 4.7.1 Object locator region

When the add locator is enabled, the object locator will teach the camera to identify a specific mark. The selected object region will then act as a reference point to orient and assist the camera during processing.



Figure 24 Object locator region

#### Matching robustness

Controls the accuracy in locating the components. Where values range from 1 to 6:

- **Option 1**

No specific parameters to set. Easy to use – fast option but for well-defined shapes only.



Figure 25 Option 1 SICK speed & robustness

- **Option 2**

Parameters: Edge threshold, downsample factor, and scale factor.

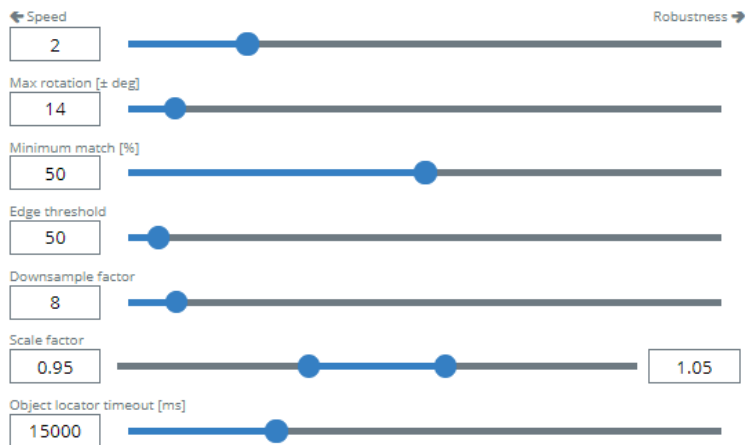

Figure 26 Option 2 Advanced SICK Speed & robustness

- Option 3 to 6 Disabled Advance settings**

No specific parameters and easy to use. Slower than Option 1 and 2, but with higher accuracy.

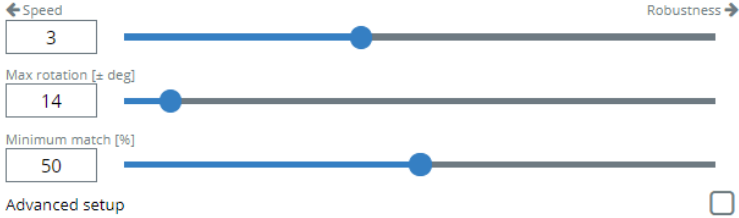

Figure 27 Option 3 - 6 Disabled Advanced settings

- Option 3 to 6 Enabled advanced settings**

Parameters: Contrast and segment size.

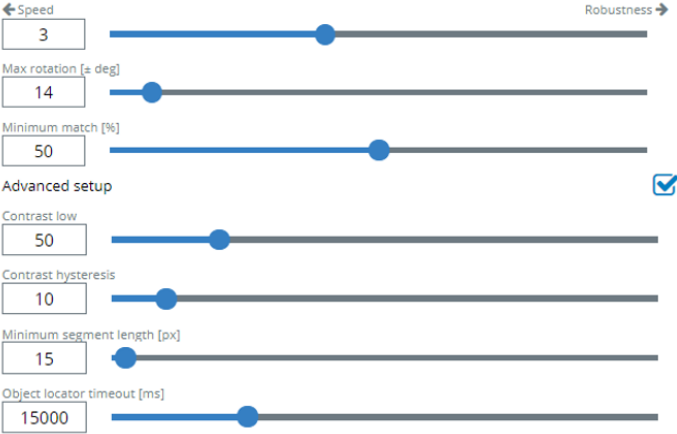

Figure 28 Option 3 - 6 Enabled advanced settings

### Edge threshold

The edge strength is calculated using a local image gradient filter. An image gradient is a directional change in the intensity in an image.

Edge strength/threshold - difference between edge intensity and background Intensity (Contrast)

Significant edges – this value can be greater (black on white and vice versa).

Weak edges - the value should be lesser (black on dark gray and vice versa).  
The default value is 50.

- Increase the default value for very sharp and high-contrast edges.
- Reduce the default value for lower contrast edge.

### Downsample factor

Sets how many times the image is downscaled before the object search is performed. If there is trouble on finding the object or if teach process fails, it is advisable to reduce the value; recommended values are from 4 to 10.

This feature sets the downsample factor in x & y dimensions of the image. If the original image has (M, N) size, the downsample image has (M/d, N/d), where d is the downsample factor.

- Increasing this value will reduce the computation time, but will also reduce the accuracy.



---

You may use a higher downsample factor for clean scenes with minimum background clutter. Decrease the value, if you encounter teach failures or when not finding the edge.

---

### Scale factor

Sets the scale interval in order to teach the size. The points on each end of the bar reflect a scale factor. In order to favorably find a taught object in the acquired image, taught object must be set more or less bigger or smaller.



---

Defines how much the shape can be smaller and bigger compared to reference shape. By setting both values to 1, the algorithm searches for exactly the same size of shape. Decreasing the first value to 0.5 will force the algorithm to look even for a half-sized shape. Increasing the second value to 2 will also look for a double-sized shape. This setting has a great impact on the search speed.

---

### Object locator timeout

Sets the allowed maximum time to search for the locator.

### Advanced setup

The parameters for advanced setup determine the contrast of what the model points must have. The contrast is a measure for local gray value differences, between object & the background, and between different parts of the object.

**Contrast low** - the lowest value used for threshold

**Contrast hysteresis** - high threshold value; where, low + hysteresis

**Minimum segment length** - sets the minimum length of the found components.

**Timeout** - determines the maximum time that the locator object tries to find the shape.

## 4 GETTING STARTED

---

### 4.7.2 Mask region

The masked region is subtracted from the object locator region, where the resulting mark will not contain edges from the mask region. This action is most favorable in eliminating any changes in text or character print of the label sample.

- Maximum rotation - Maximum rotation sets the rotation interval and restricts the range of rotation of a searched object.
- Minimum match - match setting tells how well the located object must match. The match score can be set between 0.05 (lower value) to 0.95 (higher value).

### 4.7.3 Search area region

Defines the region of interest where the object is searched within the area of the object locator. The search area can easily be adjusted/resized which creates faster search inspection. Only the center of the shape must be located within the search area, in order for the algorithm to find it.

### 4.7.4 Region shape

Shape type is a geometric shape of a region and is placed where we execute a reading. The characters are identified within this shape region.

Supported region shapes are the following:

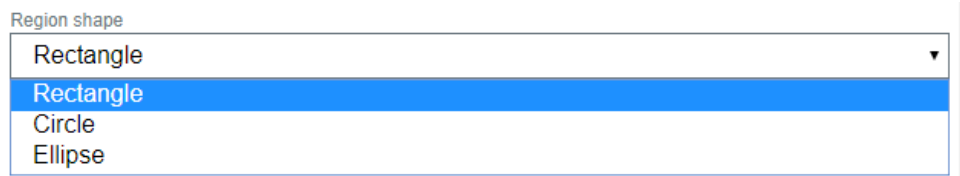

Figure 29 Region shape

4.7.5 How to adjust the object locator regions



In order to improve the Object locator speed, you should focus most of the time on influencing the features. The speed optimization should start within the adjustment of the **Speed/robustness** slider.

There are multiple shape locating algorithms in setting the object locator:

1. **Speed**

Values 1 and 2 algorithm grant faster processing (accelerated algorithm).

**Option 1 Accelerated locator**

No specific parameters to set. Easy to use, faster option but for well-defined shapes only. When the teach process fails, you should try different shape or you can switch to option 2.

Speed ← 1 → Robustness →

Max rotation [± deg] 14

Minimum match [%] 50

Figure 30 Option 1 Accelerated locator

**Option 2 Advanced Accelerated locator**

Recommended option to try first. Fast with various settings options.

Speed ← 2 → Robustness →

Max rotation [± deg] 14

Minimum match [%] 50

Edge threshold 50

Downsample factor 8

Scale factor 0.95 1.05

Object locator timeout [ms] 15000

Figure 31 Option 2 – Advanced accelerated locator

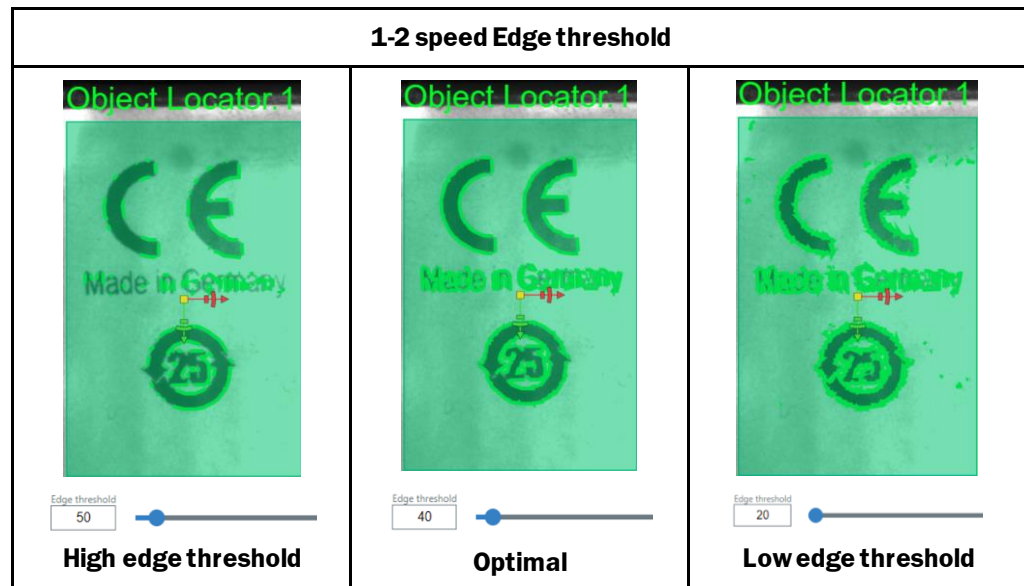

Figure 32 1-2 Speed Edge threshold



Adjusting the Downsample factor and max rotation settings usually has less impact on speed, but should still be considered for applications requiring maximum speed.



## 2. Robustness

Values 3 ... 6 algorithms offer higher stability and are recommended in applications that do not require:

- High process speeds
- Applications with a high variability in the positions, rotations, or reference shape angle relative to the camera.

### Algorithms:

- 1 and 2 algorithms – FPGA accelerated algorithms.
- 3 and 4 algorithms - are able to find shapes that are not scaled.
- 3 algorithm – without subpixel accuracy. Faster than 4 algorithm.
- 4 algorithm – with subpixel accuracy.
- 5 and 6 algorithms – can find scaled shapes according to parameter scale factor.
- 5 algorithm – without subpixel accuracy. Faster than 6 algorithm.
- 6 algorithm – with subpixel accuracy.

**Option 3-6 Disabled Advance settings**

No specific parameters and easy to use. Slower than Option 1 and 2, but with higher accuracy.

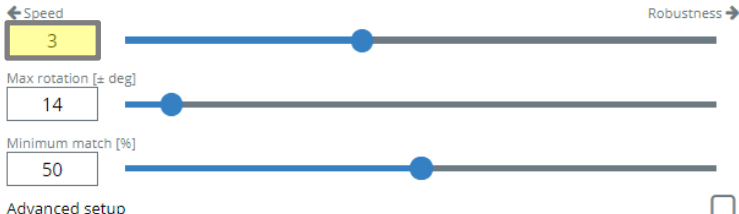

Speed ← 3 → Robustness →

Max rotation [= deg] 14

Minimum match [%] 50

Advanced setup

Figure 33 Option 3-6 Disabled Advanced settings

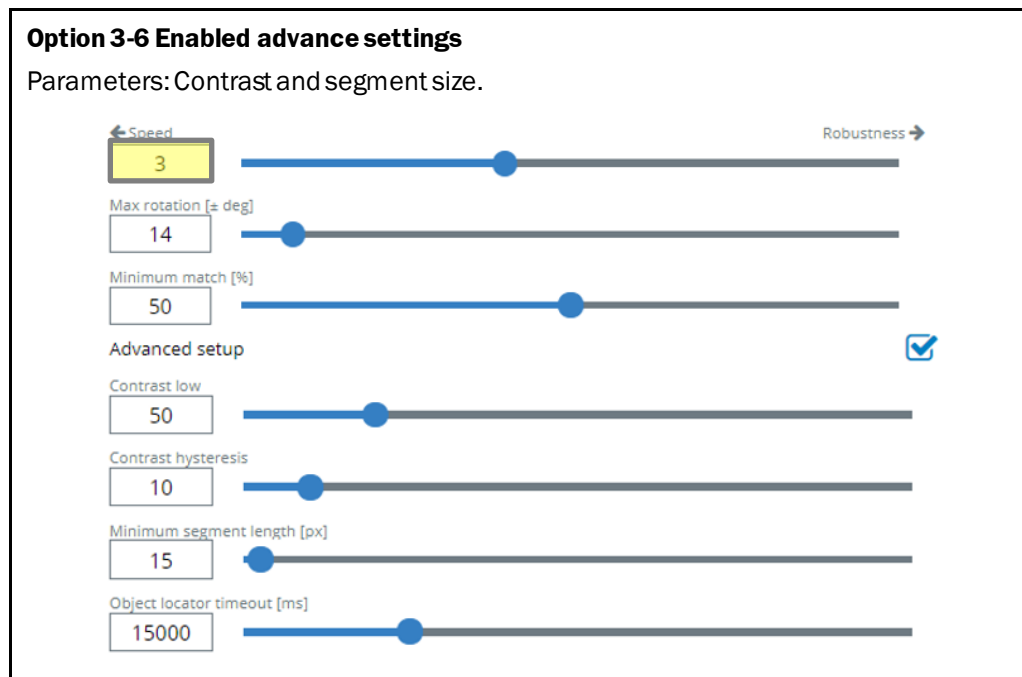

Figure 34 Option 3-5 Enabled Advance settings



<b>Contrast low</b>		
<p>For this sample, try to avoid detecting the noise around the well-defined object.</p> <p> Set the contrast low, contrast hysteresis, and minimum segment length to highlight only the contours, and if possible, no noise present.</p>		
 <p>Advanced setup Contrast low: 70</p>	 <p>Advanced setup Contrast low: 30</p>	 <p>Advanced setup Contrast low: 10</p>
<p><b>High contrast</b></p> <p>The high contrast sample shows incomplete highlighted edges.</p>	<p><b>Optimal</b></p> <p>The image shows favorable filtered pixels.</p>	<p><b>Low contrast</b></p> <p>Adjusting to a lower value will make the contrast adjustment very sensitive, that it will be able to detect minor pixels.</p>

Figure 35 Contrast low



Segment length adjustment		
<p><b>i</b> Set the minimum segment length to highlight only the contours, no noise present.</p>		
 <p>Minimum segment length [px] 80</p>	 <p>Minimum segment length [px] 15</p>	 <p>Minimum segment length [px] 10</p>
<p><b>High min. segment length</b></p> <p>When minimum segment length was set to 70, the result of the image shows incomplete highlighted edges. We must reduce the segment length value to attain the desired edge result.</p>	<p><b>Optimal</b></p> <p>The image result shows filtered pixels with favorable edge detection.</p>	<p><b>Low min. segment length</b></p> <p>The image result using low minimum segment length values, shows unfavorable pixels that need to be filtered out to achieve a good image sample.</p>

Figure 36 Segment length adjustment

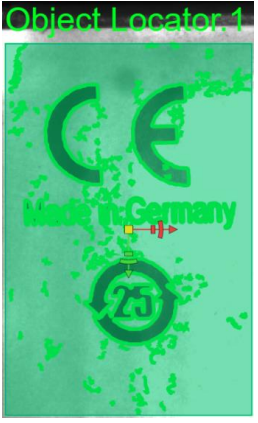

When to enable the advance settings	
	
<p><b>i</b> If your image result appears similar as this sample, where all edges are highlighted, then there is no need to adjust the settings.</p>	<p><b>i</b> If your image result appears with incomplete or edges that are not highlighted, then you will need to enable the advance setting.</p>

Figure 37.....Enabling the advanced settings

4.7.6 How to create the Object locator

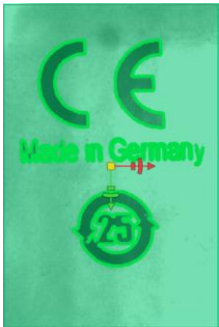

Please be informed that you must be a “Service” level user in order to access the Object locator settings tab.



Please be informed that any changes applied will only be saved, if you have re-activated the  button.

All inspection regions will be displayed after image processing is finished with a short delay.

**Proceed to create the Object locator region as follows:**

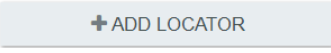
1. Click the  button.

2. Select the applicable region shape.

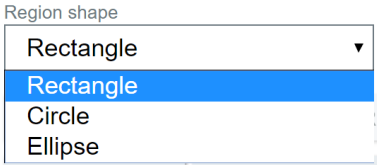

3. Change the pointer to select.

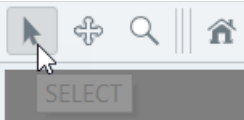

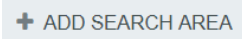
4. Select  to define the ROI, where the mark/object is most likely found (within the area) in the object locator.

## 4 GETTING STARTED

- Place the search area region shape on the desired region of interest.
- Adjust the Speed/Robustness parameters and select the optimal locator detection. Select from the six Speed/Robustness parameter options in order to achieve the best results.



Options 1 and 2 (speed) are faster than 3 to 6 (robustness), but with a higher chance of unfavorable results.

- Adjust the maximum rotation. Increase the rotation value, it allows the locator to search in a different rotation (+/- 180°), of the shape. But if set with no tolerance (+/- 0° - 1°) then there is a higher chance for unfavorable results.



Always leave a favorable (robust) degree of freedom.

- Maximum rotation

Max rotation [± deg]

14

- Minimum match

Minimum match [%]

50

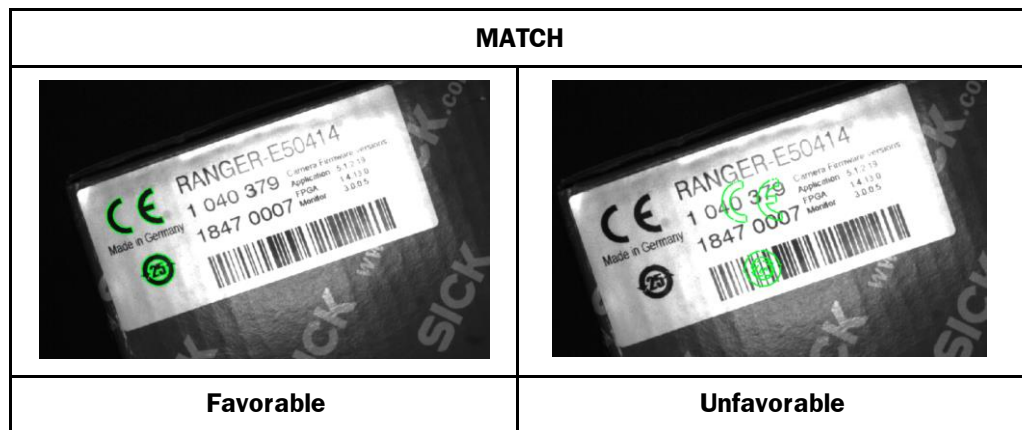



Figure 38 Favorable and unfavorable results of shape location

**Match scenario example:**

If you experience a situation similar with the unfavorable image (where the object is found on a different location), you must increase the minimum match value or adjust the settings of Object locator.

Recommended values are around 80%.

 You must adjust the match settings conservatively, in order to control the step-by-step adjustment.

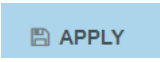
- 8. When all adjusted settings are finalized, click the  button to confirm.
- 9. Then, verify on the UI window if the shape is correctly highlighted.





If a warning occurs, please try to adjust the settings again.



Figure 39 Teaching process failed



If an object is not found, try to decrease the downsample factor first, if Option 2 is being used. Moving to a higher speed/robustness option will most likely help.

If after adjusting the settings and the image result has not improved, then try to place the object locator onto a different area (object, symbol, drawing, etc.) of the image sample.

---



When the object locator sample is enclosed in a frame, you can utilize the **Mask region** function to define and identify the component inside the frame/borders. This action is most favorable in eliminating any changes in text or character print of the label sample.

---



4.7.7 Mask region

- 1. Click the **+ ADD MASK** button. You may add additional mask if needed.
- 2. Select the applicable region shapes.

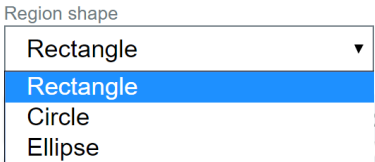

- 3. Place the mask region shape inside the frame/borders.

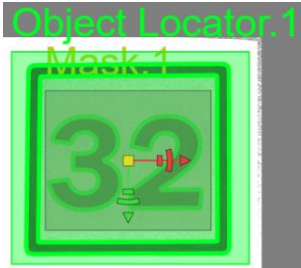

- 4. Then, select **APPLY** button to verify changes.
- 5. You will notice that the mask area will be subtracted from the selected area of the region.

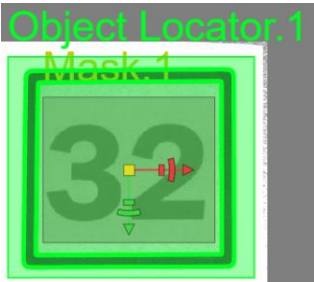



## 4 GETTING STARTED

---

### 4.7.8 How to remove a region in the Object locator

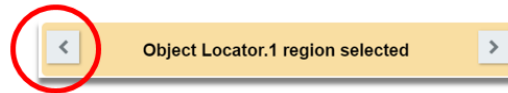
1. Select the region that needs to be removed by clicking on the relevant region shape or simply click the arrow.

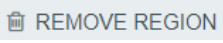

- Object locator region
  - Search area region
  - Mask region
2. Select the  button.
  3. Then, select the  button to confirm changes.
  4. You will notice that the selected region for removal will not be present.

### 4.8 OCR/OCV tab

When enabling the OCR/OCV settings tab, you will be able to teach the selected OCR/OCV region.



Please be informed that correct character/numbers are alternately highlighted in green and aquamarine. Fully highlighted characters and color difference between two adjacent characters is prerequisite for a successful OCR/OCV result.

#### Required character dimensions

Please be informed that each character must be at least 16 x 16 pixels size (does not apply for dots and thin characters like “l”). We recommend the minimum height of each character around 50 px, for better performance.

**OK OCR**

**Result: Passed**

OCR:1: LABELCHECKERLBCZ

- OCR text read
- Dimensions:
 

row	column	angle
60.69px	361.41px	0.31deg
- minimum confidence: 99.99
- character confidences:
 

L	A	B	E	L	C	H	E	C	K
99.99%	100.00%	99.99%	100.00%	99.99%	99.99%	100.00%	100.00%	99.99%	100.00%
E	R	L	B	C	C	Z			
100.00%	100.00%	99.99%	99.99%	99.99%	99.99%	100.00%			
- Processing time: 201ms

All OCR inspections Processing time: 201ms

---

2D Code:1:  
 LABEL\*CHECKER\*Label\*inspection\*solution\*for\*1D\*and\*2D\*codes\*and\*print\*quality\*control.\*www.sick.com\*\*

- 2D code found
- Dimensions:
 

row	column	angle
208.75px	358.58px	0.00deg
- print quality: 4.00
- Processing time: 139ms

All 2D code inspections Processing time: 140ms

Complete Processing time: 343ms

**Not OK OCR**

**Brief result**

OCR:1: **OCR text could not be read**

Figure 40 OCR/OCV OK & not OK results

## 4 GETTING STARTED

---

### 4.8.1 Add OCR/OCV region

Activating the “Add OCR/OCV region” button will enable you to set up the region parameters for OCR/OCV settings.



When teaching multiple-OCR region, you must highlight the desired OCR/OCV region shape, or select the region shape using the arrow keys, in order to adjust the selected region's parameters.



### 4.8.2 Region shape

Shape type is a geometric shape of a region and is placed where we execute a reading. The characters are identified within this shape region.

The supported shapes are as follows:

- Rectangle
- Circle
- Ellipse

### 4.8.3 Print type

The print type can be switched accordingly to the type of text and background color of printed label samples.

#### **Black on white**

Enable the black on white button mode, if the expected text is printed on a light-colored background.

#### **White on black**

Enable the white on black button mode, if the expected text is printed on a dark-colored background.

#### **Is text on a single line?**

Enable this feature if the character is read in single-line manner.



#### 4.8.4 Thresholding method

##### Manual threshold

Sets the threshold in selecting the pixels, depending on their intensity (brightness). According to the option “White on black” or “Black on white”, the lighter/darker pixels than the threshold will be selected.

Adjusting of hysteresis threshold will filter out any pixels with undesirable intensity.

All pixel of a region fulfills the condition and are kept as potential characters. This method is not suitable for changing the light condition, only for stable light condition.

- Threshold (intensity) – The manual threshold selects the pixels from the input image, whose gray values are lower than the selected threshold.

##### Local threshold

The local threshold segments an image to smaller parts according to the set mask size and adjust the threshold for each segment dynamically. Automatically determines the threshold for each pixel from OCR/OCV region based on its surroundings:

Mask size x Mask size

- Local threshold mask size - Size of neighborhood in which the local threshold is calculated.

##### Auto threshold

The auto threshold segments an image determined from its histogram. The threshold level automatically adjusts the contrast between the characters, the background, including each character (locally). Threshold computation is based on the entire OCR/OCV region.

Changing the character surroundings affects the value of the threshold.

Enabling the auto threshold will automatically adjust the settings. You only need to click the capture image.



---

You will notice that when the Auto threshold is selected, the threshold slider will be invisible and you will not be able to adjust the threshold.

---



---

The auto threshold can be slower in reading, but highly recommended for inconsistent image samples and complicated backgrounds.

---

## 4 GETTING STARTED

---

### 4.8.5 Maximum mismatch

Used for a number (“n”) of letters where recognition can fail. The evaluation will be still considered OK unless the result of another setting prevents it.

- If OCV is selected, verification of “n” letters can fail.
- If the minimum confidence is enabled, “n” letters can have lesser confidence than minimum.
- If both options were selected, then “n” letter can fail due to verification/confidence or both.

Highlights of results:

**Green** – enough confidence.

**Red** – with sufficient confidence, but does not match to specific pattern.

\* - If confidence is low.



---

If **OCV** option is selected and the minimum confidence option is enabled, then the result of inspection is OK, if the number of uncertain recognized characters is lesser or equal than the maximum mismatch.

If **OCR** option is selected and the minimum confidence option is enabled, then the result of inspection is OK, if the number of uncertain recognized characters is lesser or equal to the maximum mismatch.

An “uncertain” recognized character, is a character which does not match the expected character or a character recognized with lesser confidence than minimum confidence.

---



---

Inspection fails, if the number of “uncertain” read characters is greater than the maximum mismatch.

---

### 4.8.6 Specify number of characters

The value of the desired 1D code characters can be set or changed simply through adjusting the slider.

4.8.7 CRC (Cyclic Redundancy Check)

A cyclic redundancy check (CRC) is an error-detecting code commonly used in digital networks and storage devices to detect accidental changes to raw data. Blocks of data (string of characters) entering these systems get a short check value attached, based on the remainder of a polynomial division of their contents. On retrieval, the calculation is repeated to verify if the string is recognized correctly.

**CRC check and standards:**

- SEMI M12-0998E
- PSA
- AUTOSAR CRC 8 SAE-J1850



Figure 41 CRC check and standards

4.8.8 Font

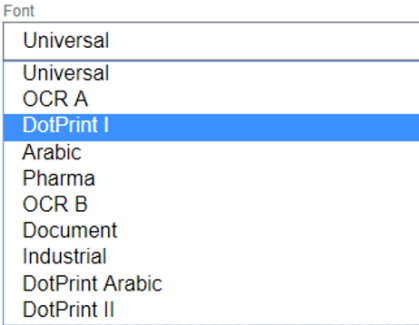

Figure 42 Font types

The selections for pre-defined standard fonts are as follows:

**Industrial**

Fonts samples such as: Arial, OCR-B, sans-serif, sans serif, gothic, or simply sans. Letterform which does not have extending features called serifs at the end of strokes.

ARIAL GOTHIC  
SANS SERIF SERIF

## 4 GETTING STARTED

---

### Document

Fonts of monospaced typefaces such as: Courier, Arial, as well as, serif typeface Times new roman.

Courier Arial Times

### Dot Print

Digits and text created from sequential dots.

DOT PRINT

### Pharma

Standard fonts used for pharmaceutical and medical packaging solutions.



### OCR – A

Monospaced fonts (American) with thick strokes to form recognizable characters.



### OCR – B

Monospaced natural fonts (European fonts) with thick strokes to form recognizable characters.



### Arabic numbers

Standard monotype Arabic numbers.

European	0	1	2	3	4	5	6	7	8	9
Arabic-Indic	٠	١	٢	٣	٤	٥	٦	٧	٨	٩



4.8.9 Character type

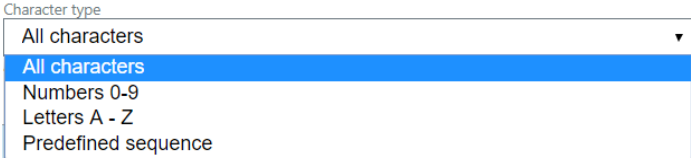

Figure 43 Character types

- All Characters – All characters and punctuation are read (ABCDEFGHIJKLMNOPQRSTUVWXYZ1234567890).
- Only numbers – Strictly numbers and punctuation are read (1234567890).
- Only letters A-Z - Only letters and punctuation are read (ABCDEFGHIJKLMNOPQRSTUVWXYZ).
- Predefined sequence - Text input of specify string.
  - Specific string



A few font packages such as Pharma or customized fonts do not support Character type selection.



When the predefined sequence is enabled, the specific string sample must be arranged according to following rule:

- A = Capital letter
- 1 = Number
- \* = Any character

Specify String: 'A' Capital letter, '1' Number, '\*' Any character

## 4 GETTING STARTED

### 4.8.10 Minimum confidence

Each letter is recognized with a probability; it describes the similarity between its patterns, as well as read letter. You can adjust the minimum characters confidence [%] to reject letters with low match.

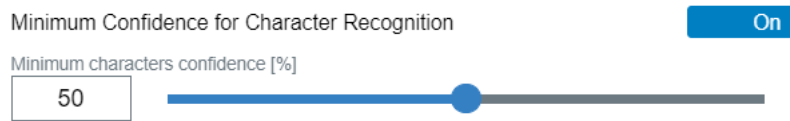

Figure 44 Minimum character recognition adjustments



Using this feature with font packages (document, industrial, etc.) containing multiple fonts has lower confidence reliability, via comparison with multiple variants of the same character. A decrease of confidence can also occur with similar characters such as "O" and "0" (zero).

### 4.8.11 Reading type

#### OCR

OCR reads a text string and is capable to read poor quality and damaged text. Use the OCR type, when you only need to read the text string sample.

**Character recognition**

#### OCV

The OCV (optical character verification) reads a text string, as well as comparing the previously taught-in text with the text found on the object.

Use the OCV type, when the text string sample is already known, and to validate the legibility of the text.

**Character verification**

### 4.8.12 Expected text counter

#### Keep value

The expected text value will be the same.

#### Increment

After one iteration (trigger pulse) the expected text value will be increased by one (+1), respectively.

#### Decrement

After one iteration (trigger pulse) the expected text value will be decreased by one (-1), respectively.

4.8.13 Types of image filter

**Emphasize** – Choose this feature to enhance the contrast of the image/text and emphasizes high frequency areas of the image (edges and corners). The resulting image will appear sharper.

#	Image filter	Parameters
1	Emphasize	Width: 7, Height: 7, Factor: 1
Filter		
Emphasize		
Width [px]	Height [px]	Factor
7	7	1

Figure 45 Emphasize - Image filter

**Illuminate** – Choose this feature to illuminate the image. Very dark parts of the image will be more illuminated, very light ones will be “darkened”.

- Filter mask height – adjusted height of the image.
- Filter mask width – adjusted width of the image.
- Filter mask factor - filtered multiplicative light.

#	Image filter	Parameters
	Illuminate	
Filter		
Illuminate		
Width [px]	Height [px]	Factor
7	7	1

Figure 46 Illuminate - Image filter

## 4 GETTING STARTED

---

**Shock filter** – Choose this feature to apply a shock filter into the input image to sharpen the edges contained in it.

- Theta – time step
- Mode – type of edge detector
  - Lap lace
  - Canny
- Sigma – smoothing of edge detector
- Iterations – number of iterations

The screenshot shows a software interface for the 'Shock filter' under the 'Image filter' category. The 'Filter' dropdown is set to 'Shock filter'. Below it, there are four parameter controls: 'Theta' is a text input field with the value '0.5' and two blue arrow buttons; 'Mode' is a dropdown menu currently showing 'Laplace'; 'Sigma' is a text input field with the value '1' and two blue arrow buttons; and 'Iterations' is a text input field with the value '2' and two blue arrow buttons.

Figure 47 Shock filter - Image filter

**Erosion w/ rectangle mask** - erodes a region with a rectangular structuring element.

- Width – width of a rectangle structuring element.
- Height – height of the rectangle structuring element.

The screenshot shows a software interface for the 'Erosion with rectangle mask' under the 'Image filter' category. The 'Filter' dropdown is set to 'Erosion with rectangle mask'. Below it, there are two parameter controls: 'Width [px]' is a text input field with the value '7' and two blue arrow buttons; and 'Height [px]' is a text input field with the value '7' and two blue arrow buttons.

Figure 48 Erosion with rectangle mask -Image filter

**Dilation with rectangle mask** – dilates a region with a rectangular structuring element.

#	Image filter	Parameters
	Filter	
	Dilation with rectangle mask ▼	
	Width [px]	Height [px]
	7 ▲ ▼	7 ▲ ▼

Figure 49 Dilation with rectangle mask - Image filter

**Erosion with circle mask** – erodes a region with a rectangular structuring element.

#	Image filter	Parameters
	Filter	
	Erosion with circle mask ▼	
	Radius [px]	
	3.5 ▲ ▼	

Figure 50 Erosion with circle mask - Image filter

**Dilation with circle mask** – dilates a region with a circular structuring element.

#	Image filter	Parameters
	Filter	
	Dilation with circle mask ▼	
	Radius [px]	
	3.5 ▲ ▼	

Figure 51 Dilation with circle mask - Image filter

## 4 GETTING STARTED

### 4.8.14 How to manage the image filters



Please be informed that you must be a “Service” level user in order to access the Image filters settings.



Please be informed that any changes applied will only be saved, if you have re-activated the  button.

All inspection regions will be displayed after image processing is finished with a short delay.



We need to utilize all image filters from the list in a given order, before the character recognition process. The image filter serves as enhancement for the image/text.

#### Proceed as follows to Add filter:

1. Select the applicable filter:

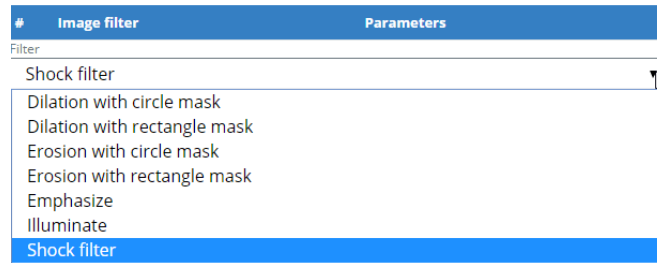
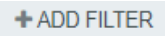
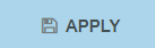

Figure 52 Image filters - Parameters

2. Apply the necessary parameter values for your selected filter type. Please refer to [subsection 4.8.15](#) to know which type of image filter parameter to use.
3. Select the  button.
4. Then click the  button.
5. Afterwards, the selected filter type and adjustments will be displayed.

#	Image Filter	Parameters
1	Emphasize	Width: 7, Height: 7, Factor: 1

**Proceed as follows to Modify filter:**

1. Highlight the filter type to be modified.

#	Image Filter	Parameters
1	Shock Filter	Theta: 0.5, Mode: LAPLACE, Sigma: 1, Iterations: 2
2	Emphasize	Width: 7, Height: 7, Factor: 1

2. Apply the necessary adjustments.

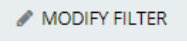
3. Then click the  button.

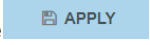
4. Afterwards, select the  button to confirm changes.

**Proceed as follows to Remove filter:**

1. Select the image filter to be removed

#	Image Filter	Parameters
1	Circle dilation	Radius: 6.5
2	Erosion	Width: 6, Height: 7

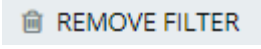
2. Click the  button.

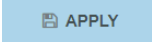
3. Then, select the  button to confirm changes.

## 4 GETTING STARTED

### 4.8.15 How to utilize each image filter



Please be informed that you must be a “Service” level user in order to access on how to adjust the filter settings.



Please be informed that any changes applied will only be saved, if you have re-activated the  button.

All inspection regions will be displayed after image processing is finished with a short delay.

#### Filter setting types:

1. **Image filters** - These filters affect the image before the OCR reading starts.

- Shock filter - Sharpens a defocused image.

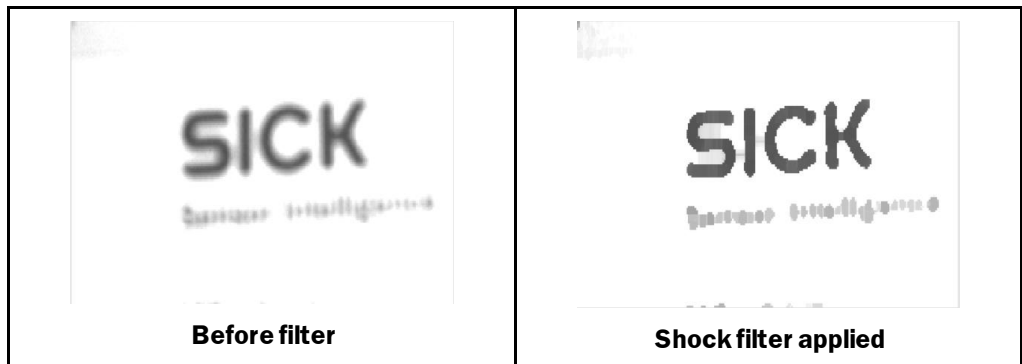

Figure 53 Shock filter

- Emphasize filter – Enhances image contrast.

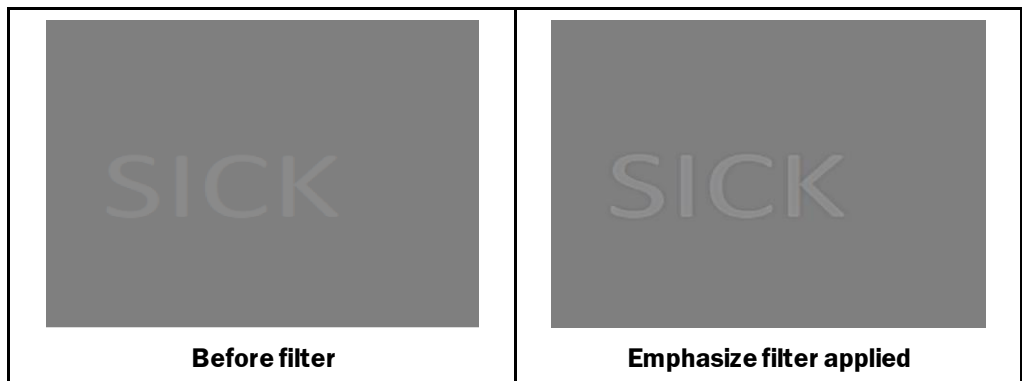

Figure 54 Emphasize filter



- Illuminate filter - Enhances detail in bright and dark regions.

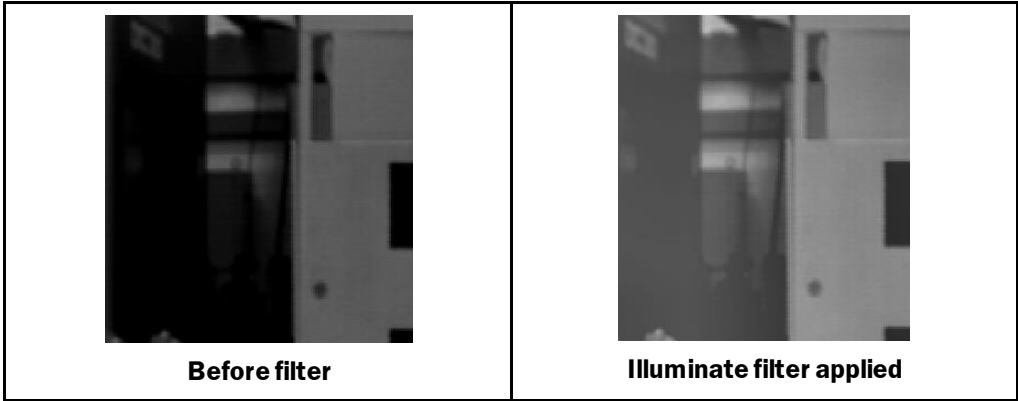

Figure 55 Illuminate filter

2. **Region filters** - affects the thresholded region (highlighted pixels in the region).

- Erosion – such filter erodes thresholded regions. Makes the region smaller and can disconnect some bigger areas and clears smaller areas, e.g. salt & pepper noise.

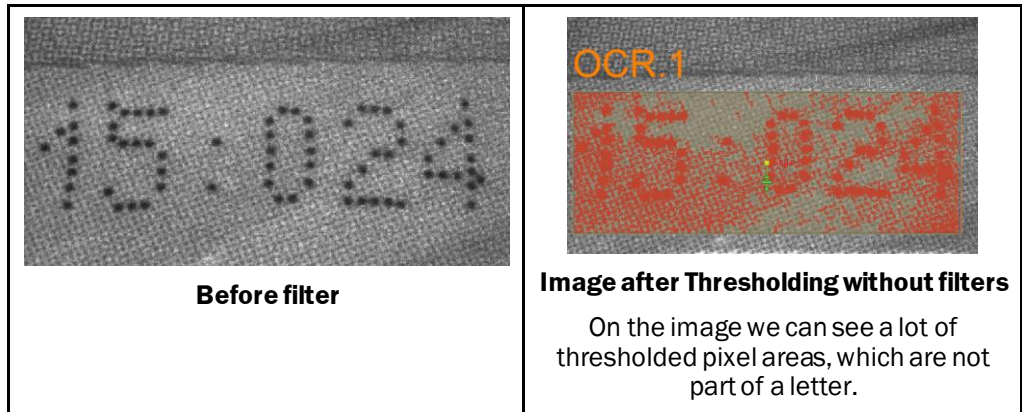

Figure 56 Region filter

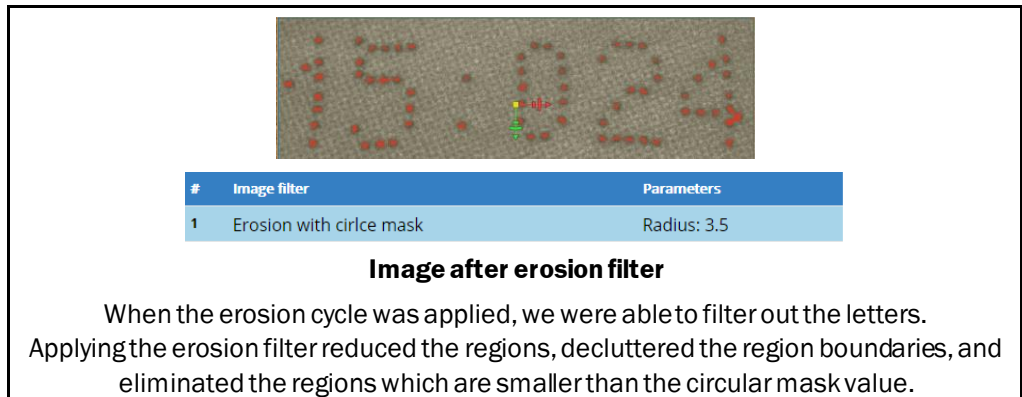

Figure 57 Image after Erosion filter

- Dilation filter - Such filter dilates thresholded regions. Makes regions bigger and can connect closely placed regions.

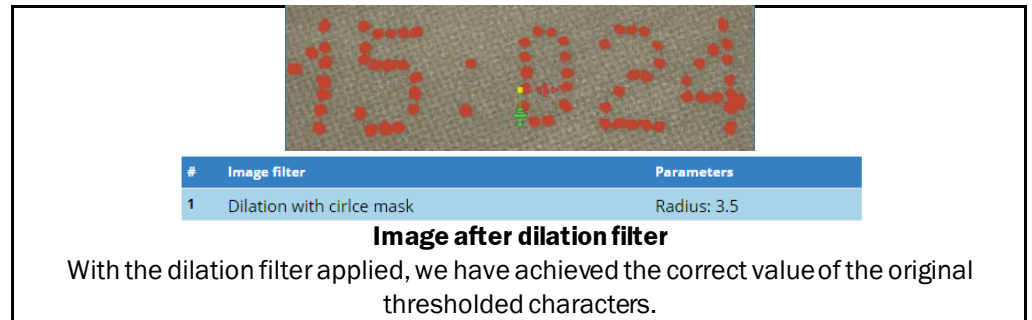

Figure 58 Image after Dilation with circle mask



You can create the opening filter by adding erosion filter followed by dilation filter using the same structuring element for both operations.

- **Open** eliminates foreground features smaller than the structuring element, smoothed contours, suppresses small features in the image, and removes sharp protrusions of shapes.



You can create the closing filter by adding dilation filter followed by erosion filter using the same structuring element for both operations.

- **Close** eliminates background features smaller than the structuring element, and blocks up narrow channels in shapes.

## 4 GETTING STARTED

---

### 4.8.16 How to teach the OCR/OCV region



---

Please be informed that you must be a “Service” level user in order to access the OCR/OCV settings tab.

---



---

Please be informed that any changes applied will only be saved, if you press the  APPLY button.

---

All inspection regions will be displayed after image processing is finished with a short delay.

---

#### Please proceed as follows:

1. Click the  button.
2. Select the region shape.



3. Adjust the region shape using the  pointer.
4. Drag the region shape within the desired ROI.



---

Once the region is on its position, we highly recommend to first specify the suitable Character segmentation, followed by threshold and Image filter setup, before setting up any minor OCR/OCV setting adjustments.

---

5. Select the reading type:
  - OCR
  - OCV

- 6. When OCV is selected, choose the expected text and insert the expected character/text (exact text) that is printed on the label sample.

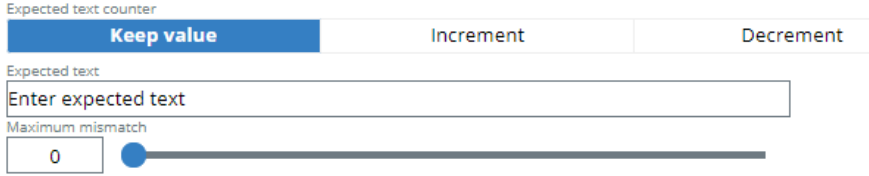

Figure 59 Expected text counter

**Wildcards**

You may also use wildcards in the expected text counter. Wildcards can be also used when the expected text is sent from the external device (PLC).

E.g., A[B;0]1234[5-6] can be used to read as OK text AB12345 and A012346. When [] is entered in the expected text field, notification about correct syntax is displayed.

The following image works for “SICK” text sample:



Figure 60 SICK text sample



When creating two or more OCR/OCV, you can utilize the arrows to select the region number.



- 7. Select the suitable **character segmentation** type, and adjust the applicable settings.

- **Separated characters** – Fastest character algorithm, ideal for text with sufficient letter spacing.

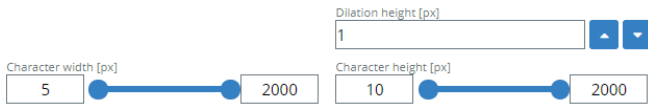

Figure 61 Separated characters setting



The Dilation height must be increased carefully, if there are more lines read.

- **Semi-connected** - Fast algorithm with the ability to divide touching/adjacent characters. Correct setting of minimum and maximum character width is necessary for proper operation.

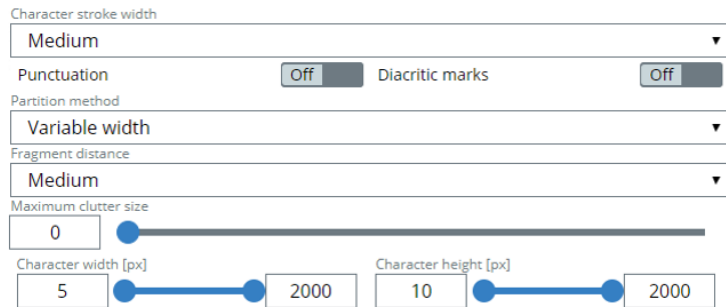

Figure 62 Semi-connected characters setting

- **Connected characters** - Slow algorithm, only suitable when other method cannot resolve it.

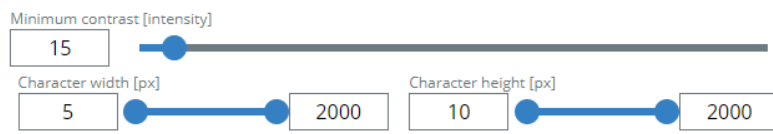

Figure 63 Connected characters settings

- **Dot print** - Faster segmentation method. Use the dilation radius and height (dilation filter with circle mask) to connect the dots in order to create a character. The effect of this filter will not be visible on the screen.

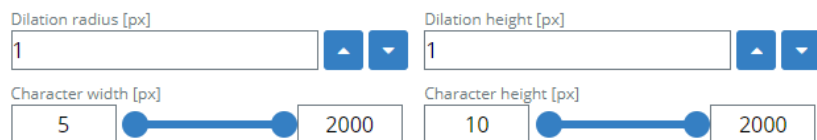

Figure 64 Dot print setting



Please refer to [subsection 4.8.174.8.17](#) on [how to select and adjust each character segmentation type](#).

8. Now, select the most favorable image filter for your label sample.



Please refer to the [subsection 4.8.14](#) on [How to manage the image filters](#).

9. Enable the Type of print.
- Black on white
  - White on black

10. If applicable, enable if text on single line.



Figure 65 Is text on a single line - enable/disable

11. Specify the following Thresholding method:

- **Auto threshold** - No parameters; easy to use. The Auto threshold is highly recommended for inconsistent sample text and complicated backgrounds. Although it will take some time during reading. Auto threshold works the same way as local threshold and automatically calculates mask size.
- **Local threshold** - Calculates the threshold on the areas, depending on the local threshold Mask size. Best used for samples with background of various shades.



Figure 66 Local threshold

- **Manual threshold** - Usually the fastest method. Best used for character/numeral samples with same/constant background/character shade.

# LABEL CHECKER-LBC-CZ

---

Figure 67 Manual threshold

12. Choose the applicable character font.

Font
Universal
Universal OCR A
<b>DotPrint I</b>
Arabic
Pharma
OCR B
Document
Industrial
DotPrint Arabic
DotPrint II



13. Select the character type.

Character type

- Predefined sequence
- All characters
- Numbers 0-9
- Letters A-Z
- Predefined sequence

- When the Predefined sequence is selected, then you can fill-in the exact character sequence of the image sample.

Specify String: 'A' Capital letter, '1' Number, '\*' Any character

A

14. Enable the minimum confidence for character recognition, and adjust the minimum character confidence, if applicable.

Minimum confidence for character recognition On

Minimum characters confidence [%]

50

15. Set the maximum mismatch, if applicable;

Maximum Mismatch

2

16. When all adjusted settings are finalized, click the APPLY button to confirm.

17. Afterwards, check the results in the Inspection result window.

**Remove OCR/OCV region**

You will be able to remove an existing OCR region by selecting the region that needs to be eliminated and afterwards clicking the remove region button.

Existing OCR region can be removed by performing the following:

**Proceed as follows:**

1. Select the region that needs to be deleted.
2. Click REMOVE REGION button.
3. Then select the APPLY button to confirm.

## 4 GETTING STARTED

---

### 4.8.17 How to select and adjust each type of Character segmentation



---

Please be informed that you must be a “Service” level user in order to access the Character segmentation settings.

---



---

Please be informed that any changes applied will only be saved, if you have re-activated the  button.

All inspection regions will be displayed after image processing is finished with a short delay.

---

There are **four** types of **Character segmentation**:

- Separated Characters
- Semi-connected Characters
- Connected Characters
- Dot print

**Separate Character**

# LABEL CHECKER-LBC-CZ

Used for character/numeral samples with a visible gap between each two consecutive characters. The fastest method.

- Dilation height  
Increases the area of highlighted pixels in vertical axis

Dilation height [px]

- Character width  
Filters out all characters with different width or height.

Character width [px]

- Character height  
Influences the minimum and maximum height of the dot/fragment.

Character height [px]

## 4 GETTING STARTED

### Proceed as follows:

1. Select the type of character segmentation.

**Separated characters**

2. Adjust the dilation height, if applicable.

Dilation height [px]  
1

3. Then, adjust the character width & height.

Character width [px] 5 2000 Character height [px] 10 2000



### The character height and width can be measured in two ways:

- Using the arrow tool – When you place the arrow tool on the character, the coordinates will show and you can calculate moving the mouse from the right side of the characters to the left side.
- Using blob tool – Highlight the characters and it will tell you the size of the characters.

### SEPARATED CHARACTERS SCENARIO EXAMPLE

OCR.1	OCR.1	OCR.1
<b>Brief result</b>	<b>Brief result</b>	<b>Brief result</b>
OCR.1: CCKCC	OCR.1: LABELCHECKERLBC CZ	OCR.1: LELEEL
<b>High character width value</b>	<b>Optimal result</b>	<b>Low characters width value</b>
When the character width was adjusted to 27 ... 80 px, the LBC can only find wider continuous pixel (pixel values of 27-80).	The LBC was able to find the correct width of every character pixel, when the character width was adjusted appropriately.	When the character width was adjusted from 5 ... 50 px, the LBC can only find narrower character width pixels.

Figure 68 Separated characters scenario examples

## Semi-connected

# LABEL CHECKER

Characters that are adjacent to each other.

- **Character width and height** is the most important setting of semi-connected algorithm, adjust these parameters to make the separation successful.
- **Character stroke width**  
Specifies the stroke width of the text. It is used to calculate internally used mask sizes to determine the characters. These mask sizes are also influenced through Dot print, the average Character width, and Character height parameters.
- **Punctuation**  
When this feature is enabled, the Label Checker will detect the punctuation marks, e.g. ".", ":", ",", etc., otherwise when disabled it will be suppressed.
- **Diacritic marks**  
When this feature is enabled, the Label Checker will detect diacritic marks, e.g. â, é, ö, etc., otherwise when disabled it will be suppressed.
- **Partition method**  
Using this parameter, you can specify to separate neighboring characters that are printed close to each other, or partly merged characters.
- **Fragment distance**  
This parameter influences the connection of the character fragments.
- **Maximum clutter size**  
This parameter is used if the extracted characters contain clutter, i.e., small regions near the actual symbols.
- **Character width**  
Filters out all characters with different width or height.
- **Character height**  
Influences the minimum and maximum height of the dot/fragment.

### Proceed as follows:

1. Select the type of character segmentation.

**Semi-connected**

2. Select the type of character stroke width.

Character stroke width

Medium	▼
Ultra light	
Light	
Medium	
Bold	

3. Enable the following button, if punctuation or diacritic marks are present on the character sample.

Punctuation  On Diacritic marks  On

4. Select the type of partition width.

Partition method

Variable width	▼
Fixed width	
Variable width	
None	

5. Select the type of fragment distance.

Fragment distance

Medium	▼
Narrow	
Medium	
Wide	

6. Adjust the maximum clutter size.

Maximum clutter size

0

7. Then, adjust the character width and height. This step is mandatory for proper segmentation of characters.

Character width [px]  5  2000

Character height [px]  10  2000



SEMI-CONNECTED CHARACTERS WIDTH EXAMPLE		
<p>OCR.1</p>  <p>Character width [px] 5 <input type="range" value="200"/> 200</p>	<p>OCR.1</p> 	<p>OCR.1</p>  <p>Character width [px] 5 <input type="range" value="20"/> 20</p>
<p><b>Wide width</b></p> <p><b>Brief result</b></p> <p>OCR.1: @V4@@</p> <p>The brief result only shows five read characters. Since the character width was adjusted to 200 pixels, then the LBC is only trying to read the specified character width value of 200 px.</p>	<p><b>Default value</b></p> <p><b>Brief result</b></p> <p>OCR.1: -</p>	<p><b>Narrow width</b></p> <p><b>Brief result</b></p> <p>OCR.1: L/%%4E3LEL/1VE3ISLUC0DF4E(0DK:EF7</p> <p>The LBC is only reading the character width up to 20 pixels. The character width value is too low that the LBC was not able to read a favorable result.</p>

Figure 69 Semi-connected characters width examples

**Semi-connected character scenario sample:** When segmenting characters/numerals that are almost connected/entirely connected, it very important to specify the following:

- **Character stroke width**
- **Partition method**
- **Fragment distance**
- **Character width and height**

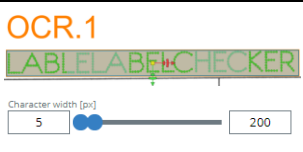
The following sample shows the character width and height with the same value, but with different Partition, distance, and stroke width values. You will be able to set the optimal result of the label sample, if you will try to establish the correct or the nearest value of the character/number pixel x, y.

<p>OCR.1</p>  <p>Character segmentation: Separated characters, <b>Semi-connected</b>, Connected characters</p> <p>Dot print</p> <p>Character stroke width: Medium</p> <p>Punctuation: Off Diacritic marks: Off</p> <p>Partition method: Variable width</p> <p>Fragment distance: Wide</p> <p>Maximum cluster size: 0</p> <p>Character width [px]: 5 57 Character height [px]: 1 302</p>	<p>OCR.1</p>  <p>Character segmentation: Separated characters, <b>Semi-connected</b>, Connected characters</p> <p>Dot print</p> <p>Character stroke width: Light</p> <p>Punctuation: Off Diacritic marks: Off</p> <p>Partition method: Fixed width</p> <p>Fragment distance: Narrow</p> <p>Maximum cluster size: 0</p> <p>Character width [px]: 5 57 Character height [px]: 1 302</p>
<p><b>OPTIMAL RESULT</b></p> <p><b>Brief result</b></p> <p>OCR.1: LABELABELCHECKER</p>	<p><b>UNFAVORABLE RESULT</b></p> <p><b>Brief result</b></p> <p>OCR.1: LABLEDABEKHECKER</p>

Figure 70 Character width and height examples

### Connected characters

0012345678901234567890123456789

Used for Character/numeral samples that are connected to each other. It is the slowest method.

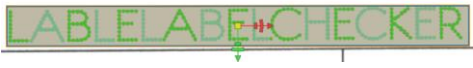
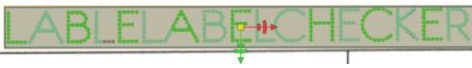
- **Minimum contrast (intensity)**

Defines the minimum contrast between the text and the background

- **Character width**

The first value is the average width of a character. The second is the minimum width of a character, and the third is the maximum width of a character. The operating entity can only set the minimum and maximum width, the average is adjusted automatically.

- **Character height**

The first value is the average height of a character. The second is the minimum height of a character, and the third is the maximum height of a character. Customer can only set the minimum and maximum height, the average is adjusted automatically.

### Proceed as follows:

1. Select the type of character segmentation.

**Connected characters**

2. Adjust the minimum contrast.



3. Adjust the character width and height.







CONNECTED CHARACTERS SEGMENT SAMPLE		
		
<b>Segments are too wide</b>	<b>Default value</b>	<b>Segments are too narrow</b>
<b>Brief result</b>	<b>Brief result</b>	<b>Brief result</b>
OCR.1: W134R91012%567N0134%M9	OCR.1: -	OCR.1: C)3:R3L1;)4I91123)4:E9

Figure 71 Connected character examples

**Connected characters scenario example:** The LBC was not successful in achieving a favorable result, by only adjusting the character width. You will notice on the next semi-connected segmentation sample, in order to segment the „00“ connected numbers, the **partition method** was adjusted to **Fixed Width** in order to specify the numeral's width measurement type.

	
<b>Brief result</b>	<b>Brief result</b>
OCR.1: CX)12345678910123456789	OCR.1: 00123456789101234567890123456789

Figure 72 Connected character scenario examples

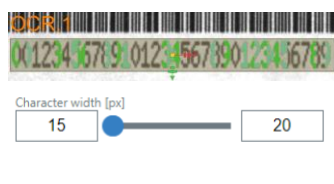
**Dot print** – Used specifically for dot print character/numeral samples.

LABEL CHECKER LBC

- **Dilation radius**  
Enlarges each dot to join them together into a character. Too high number join all letters together into one. Too low number splits one letter to two separate segments.
- **Dilation height**  
Enlarges the dots along the letter height direction. Thus, the diacritic mark is connected to a corresponding letter.
- **Character width**  
Filters out all characters with different width or height.
- **Character height**  
Influences the minimum and maximum height of the dot/fragment.



---

There is a difference between dilation in Dot Print algorithm settings and in image filters.

**Dot Print algorithm**

The dilation parameter in Dot Print algorithm is used for proper segmentation of the characters and does not affect the image sent to the reading algorithm.

**Image filter**

The dilation for image filter affects the highlighted pixels, and are sent to the algorithm.

**Proceed as follows:**

1. Select the type of character segmentation.

**Dot print**

2. Adjust the dilation radius and height, if applicable.

Dilation radius [px]  ▲ ▼      Dilation height [px]  ▲ ▼

3. Then, adjust the character width and height.

Character width [px]  ●————●       Character height [px]  ●————●

DOT PRINT SAMPLES		
<b>High dilation radius</b>	<b>OK</b>	<b>Low dilation radius</b>
<b>Brief result</b>	<b>Brief result</b>	<b>Brief result</b>
OCR.1: 1@	OCR.1: 1820306	OCR.1: 18.2TJ.0J0J6-I

Figure 73 Dot print scenario examples

Dilation height (Dot Print)	
<b>Brief result</b>	<b>Brief result</b>
OCR.1: 1820306	OCR.1: 001234567891134578912346789
<b>OK dilation height</b>	<b>Low dilation height</b>

Figure 74 Dilation height OK/not OK – Dot print

## 4 GETTING STARTED

### 4.9 1D code

When this feature is enabled, you can teach the camera to read a text sample for one-dimensional or linear codes (bar codes).

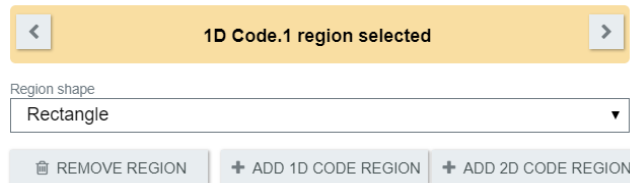

Figure 75 1D code

#### 4.9.1 1D code types

**Auto Code type** – this feature will automatically determine the type of code, when the Apply button is enabled.



The Label Checker supports an extensive list of 1D/linear code type:

- 2/5 Industrial
- 2/5 Interleaved
- Codabar
- Code 39
- Code 93
- Code 32
- UPC-A, UPC-E
- EAN-13
- EAN-8
- Pharma code
- GS1 128
- GS1 various types
- MSI
- Auto



When the Auto 1D code type detection is selected, the camera will automatically find the desired sample.

Please be informed that using the auto mode will consume more reading time in comparison with selecting the specific 1D code types.

#### 4.9.2 Inverted

The Inverted mode is used to read inverse 1D/linear codes, where black and white colors of 1D Code components are switched.

4.9.3 Specify number of characters

The value of the desired 1D code characters can be set or changed simply through adjusting the slider.



4.9.4 Quality check

Inspects the print quality of 1D/2D code. The result can be affected by external influences such as ambient light, reflections, etc., so it is necessary to ensure stable and the best possible conditions for reliable quality recognition.

**Minimum quality required**

Equivalent to OCR/OCV minimum confidence. If the quality check was enabled, then the printing quality of read 1D code is determined and compared to the required minimum quality. Higher printing quality presents positive result.

4.9.5 1D code reading type



Figure 76 Type of 1D code reading

**Code recognition**

Use code recognition when you only need to read the code.

**Code verification**

Use code verification when the code is already known, and you only need to validate the legibility.



If the code verification is selected, then you can select whether the expected text is kept or decreased/increased by one, after one inspection is executed. The expected text must be a number; when increasing or decreasing the value.



When the Code Verification is selected, then the expected text is matched to a recognized (read) text.

If the expected text is equal to read text, then the result of the inspection is positive, otherwise negative.

## 4 GETTING STARTED

---

### 4.9.6 Expected text change

#### **Keep value**

The expected 1D code value will stay the same.

#### **Increment**

After one iteration (trigger pulse) the expected 1D code value will be increased by one (+1), respectively.

#### **Decrement**

After one iteration (trigger pulse) the expected 1D code value will be decreased by one (-1), respectively.

### 4.9.7 1D code expected text

The expected 1D code must be inserted according to the exact character/text printed on the label sample.

4.9.8 How to read 1D code



Please be informed that you must be a “Service” level user in order to access the 1D code settings tab.



Please be informed that any changes applied will only be saved, if you have re-activated the  button.

All inspection regions will be displayed after image processing is finished with a short delay.

**Proceed as follows:**

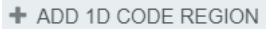
- 1. Select  button.
- 2. Choose the region shape.

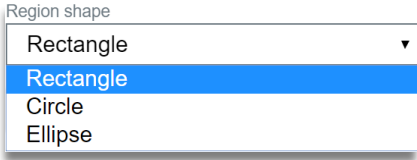

- 3. A blue region shape with label 1DCode. # will appear over the reference image.



- 4. Drag the 1D code region shape (blue) onto the desired region of interest.

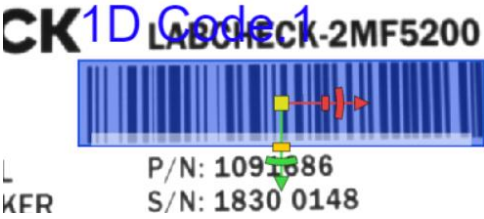

## 4 GETTING STARTED

---

5. Select the 1D code reading type.

- Code recognition
- Code verification

6. If code verification is selected:

- ▶ Select the type of expected text change.
- ▶ Fill in the exact 1D code expected text, of what is printed on the label sample.

7. Select the required 1D code type.

1D Code type

Code 128 ▼

- auto
- 2/5 Industrial
- 2/5 Interleaved
- Codabar
- Code 39
- Code 93
- Code 128**
- EAN-8
- EAN-13
- GS1 128
- PharmaCode



When the auto mode is selected, the camera will automatically find the desired 1D code type. Please observe that using the auto mode will consume more reading time, compared to directly selecting the specific 1D code type.

8. If applicable, adjust the value for the specify number of 1D code characters.

Specify number of characters

1  15



9. If applicable, enable the inverted feature for label samples of inverse 1D/ linear codes.



10. If applicable, enable the Quality check and adjust the required minimum quality.



11. When all adjusted settings are finalized, click the **APPLY** button to confirm.

12. Afterwards, check the results in the Inspection result window.

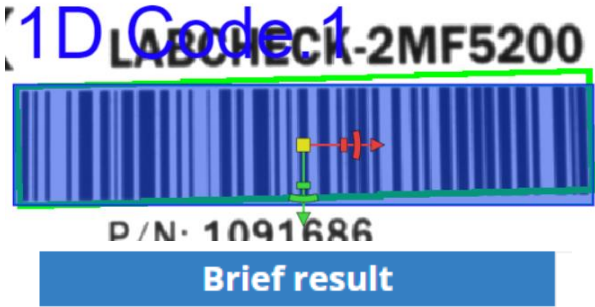

1D Code.1: **109168618300148**

## 4 GETTING STARTED

---

### 4.10 2D code

When the 2D code is activated, you can teach the camera to read a text sample for two-dimensional codes.

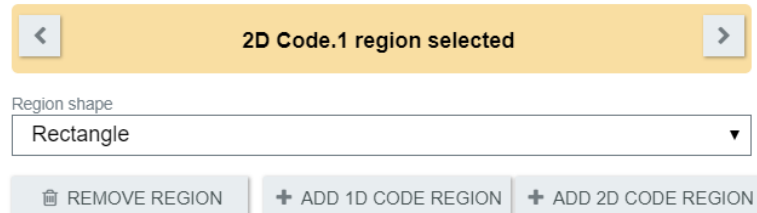

Figure 77 2D code

#### 4.10.1 2D code type

**Auto Code type** – this feature will automatically determine the type of code, when the Apply button is enabled.



The Label Checker supports the following 2D code type:

- Data Matrix ECC200
- QR code
- Micro QR code
- PDF417
- Aztec Code
- GS1 Data Matrix
- GS1 QR code
- GS1 Aztec Code

#### 4.10.2 Dot peening

Dot peening code are created from small dots.

- Threshold – Locates the dots.
- Dilation mask width – Dilates the rectangles from these dots to create a readable 2D code.
- Dilation filter – reduces the following:
  - The holes that are enclosed in a single region
  - The gaps between different regions
  - The small intrusions into boundaries of a region are filled-in

#### 4.10.3 Inverted

The Inverted mode is used for inverse 2D codes.

#### 4.10.4 Specific number of characters

The value of the desired 2D code can be set or changed by adjusting the track bar.



#### 4.10.5 Quality check

Determines how the printing quality for 1D/2D code is printed.

##### **Minimum quality required**

Equivalent to OCR/OCV minimum confidence. If the quality check was enabled, then the printing quality of read 2D code is determined and compared to the required minimum quality. Higher quality will present positive result.

## 4 GETTING STARTED

---

### 4.10.6 2D code reading type

#### **Code recognition**

Use code recognition when you only need to read the code.

#### **Code verification**

Use code verification when the code is already known, and you only need to validate the legibility.



Figure 78 2D code reading type

### 4.10.7 Expected text change

#### **Keep value**

The expected 2D code value will remain the same.

#### **Increment**

After one iteration (trigger pulse) the expected 2D code value will be increased by one (+1), respectively.

#### **Decrement**

After one iteration (trigger pulse) the expected 2D code value will be decreased by one (-1), respectively.

### 4.10.8 2D code expected text

The expected 2D code must be inserted according to exact character/text printed on the label sample.

#### 4.10.9 How to create 2D code



Please be informed that you must be a “Service” level user in order to access the 2D code settings tab.



Please be informed that any changes applied will only be saved, if you have re-activated the  button.

All inspection regions will be displayed after image processing is finished with a short delay.

#### Proceed as follows:

1. Enable the  button.
2. Select the region shape.

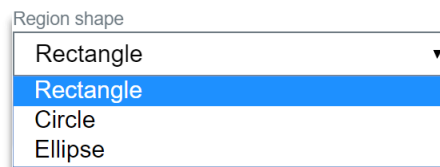

3. Cyan region shape with label 2D code. # will appear over the reference image.



## 4 GETTING STARTED

---

4. Drag the 2D region shape (Cyan) onto the desired region of interest.

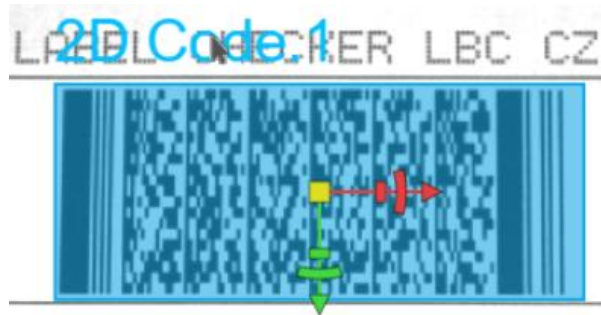

5. Select the 2D code reading type.

- Code recognition
- Code verification

6. If code verification is selected:

- ▶ Select the type of expected text change.
- ▶ Fill in the 2D code expected text (the exact text encoded in the 2D code).

7. Select the required 2D code type.

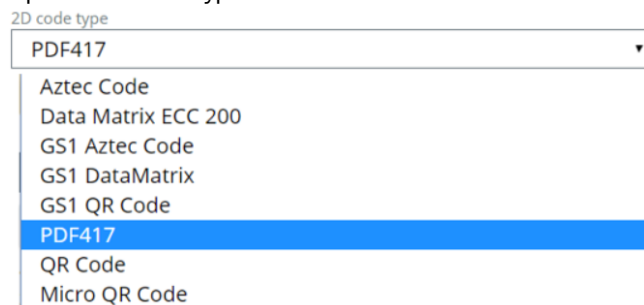

8. Enable the dot peening, if applicable.

Adjust the following settings:

- Threshold
- Dilation mask width

9. Adjust the slider for specify number of 2D code characters, if applicable.



10. If applicable, enable the inverted mode for label samples of inverse 2D codes.



11. If applicable, select Enable quality check and adjust the values of the minimum quality required.



12. When all settings are finalized click the **APPLY** button to confirm.

13. Afterwards, check the results in the Inspection result window.

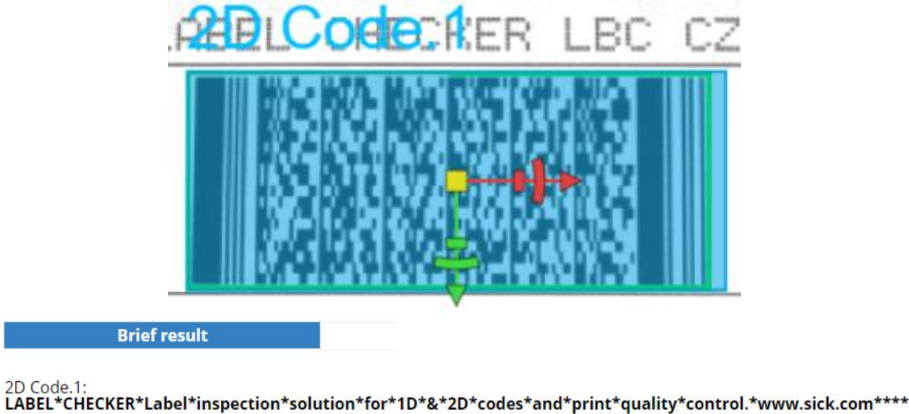

When creating two or more 2D codes, you can utilize the arrows to select the region number.



## 4 GETTING STARTED

---

### 4.11 Other inspections

The Other inspections tab will allow you to adjust the following settings:

- Pixel counter
- Pattern verification
- 2D measurement
- Blob



Please be informed that you must be a “Service” level user in order to access the following settings:

- Pixel counter
  - 2D measurement
  - Pattern verification
  - Blob
- 



Please be informed that any changes applied will only be saved, if you have re-activated the  button.

All inspection regions will be displayed after image processing is finished with a short delay.

---



### 4.11.1 Pixel counter

#### Required intensity threshold

Sets the minimum and maximum pixel intensity.

#### Area ratio

Area coverage to be evaluated.

- Area ratio with required intensity  
Area ratio [%] with required intensity specifies the range of coverage to be evaluated as OK.

#### Pixel count

Counts the number of pixels.

- Count of pixels with required intensity  
Pixel count with required intensity specifies the range of coverage to be evaluated as OK.



Please be informed that Green color highlight indicates that ROI is detected, and red indicates unfavorable ROI inspection.

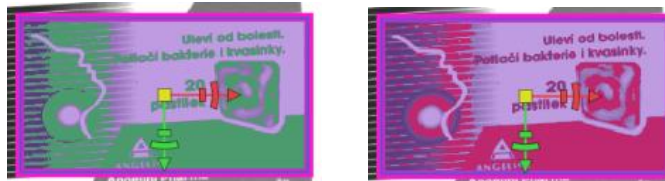



Figure 79 Pixel counter inspection comparison



Please be informed that you must be a “Service” level user in order to access the Pixel counter.



Please be informed that any changes applied will only be saved, if you have re-activated the  button.

All inspection regions will be displayed after image processing is finished with a short delay.

## 4 GETTING STARTED

---

### Proceed as follows:

1. Select the applicable Inspection to Add.

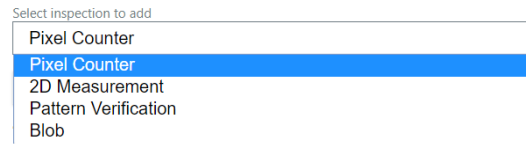

2. Then, click the **+ ADD INSPECTION** button.

3. Select the region shape.

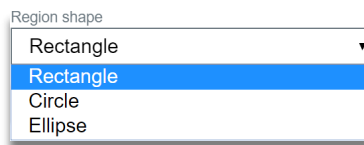

4. Pink colored region shape with label Pixel counter. # will appear over the reference image.



5. Place the pixel counter region shape (Pink) on the desired ROI.



6. Adjust the required pixel intensity.



7. Select the area ratio or pixel count.



8. Then adjust the area ratio with the required intensity or pixel count.

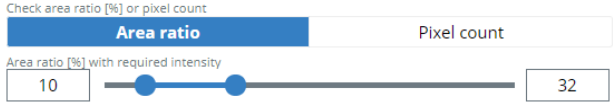

OR

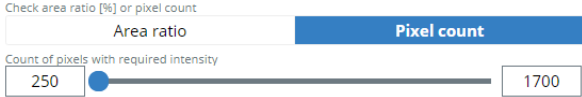

When the inspection result is highlighted with green, then the inspection is favorable.



If the inspection result is highlighted in pink, then the inspection is unfavorable.



## 4 GETTING STARTED

---

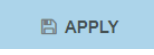
9. Select the  button to confirm.

10. Afterwards, check the results in the Inspection result window.

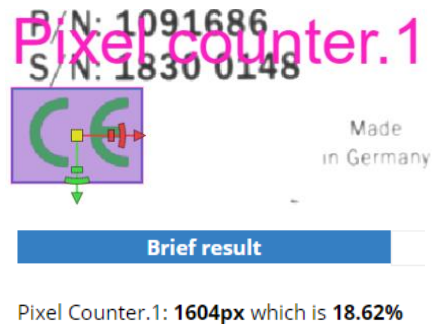

### 4.11.2 2D measurement

#### Edge length

You can filter out too short or too long edges.

#### Edge selection

- The longest contour – longest contour/edge found in the selected region.
- The most significant contour – contour/edge with the greatest intensity gradient found in the selected region, where the biggest contrast is found between the edge and the background.
- The contour closest to the opposite region - The algorithm finds the one with the shortest distance to the opposite region center.
- The contour farthest to the opposite region - The algorithm finds the one with the longest distance to the opposite region center.
- The contour farthest to the opposite region – The algorithm finds the one with the longest distance to the opposite region center.

#### Real distance

When this feature is enabled you can measure the distance between two parallel lines' edges, in order to measure the real dimensions. Such as; box, rectangle, postal markings, etc.

**Advanced setup**

- Edge threshold hysteresis- filters out the edges with too high or too low contrast (intensity gradient).
- Check distance - Checks the dimensions of the object, such as box, rectangle, postal markings, etc.
- Right angle distance

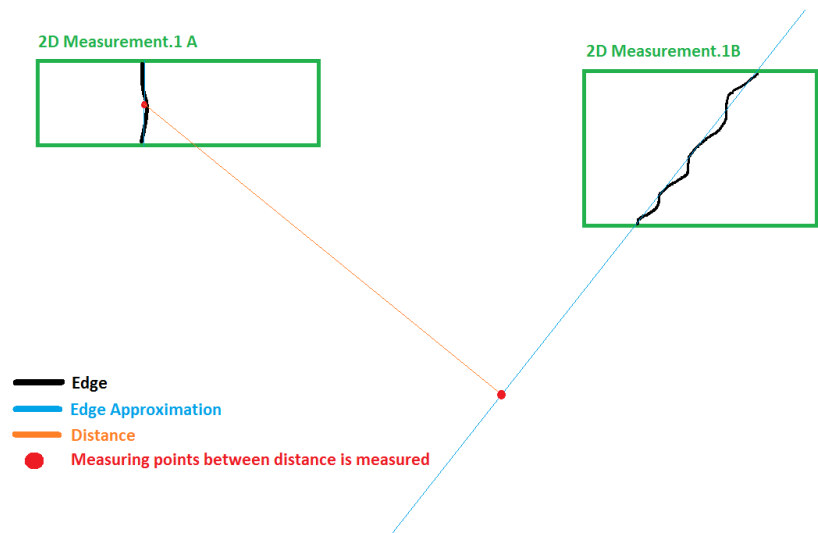

Figure 80 2D Measurement - Advanced setup

- Euclidean distance



Figure 81 Euclidean distance - 2D Measurement



If the measured object is off-range from the required settings (minimum/maximum distance and tolerance), then the inspection fails, otherwise passed.

## 4 GETTING STARTED

---



---

Please be informed that you must be a “Service” level user in order to access the 2D measurement.

---



---

Please be informed that any changes applied will only be saved, if you have re-activated the  button.

All inspection regions will be displayed after image processing is finished with a short delay.

---

**Proceed as follows:**

- 1. Select the applicable Inspection to Add.

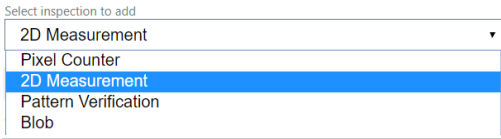

- 2. Then, click the **+ ADD INSPECTION** button.

- 3. Select the region shape.

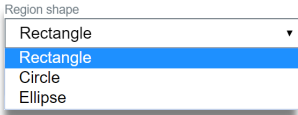

- 3. Two aquamarine colored region shape with 2D Measurement. # A and 2D Measurement. # B, will be displayed over the reference image.

2D Measurement.1 A

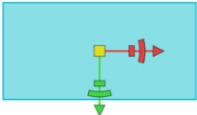

2D Measurement.1 B

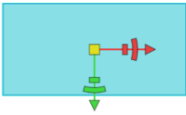

## 4 GETTING STARTED

- You must place each of the x axis (green highlight) horizontally on the desired edge for measurement. You have achieved a favorable result, if both x-axis lines are highlighted in green (edge found).

X - axis - Green

Y - axis - Red

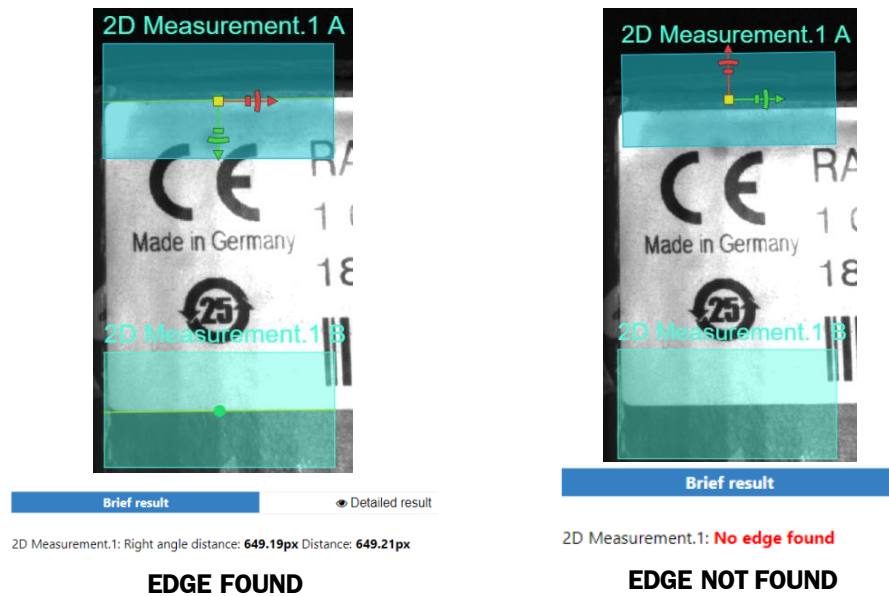
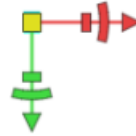

Figure 82 Correct placement of the coordinate axes



Each green arrow must be perpendicular to the edge of interest. If the y axis (red highlight) is placed on the edge to be measured, then it will produce unfavorable result (no edge found).

- Select one of the 2D measurement regions to be adjusted, by highlighting the region shape or click the arrows.





6. Set the necessary adjustments for the following settings:

Edge length [px]  
    
 Edge selection

- Edge length
- Edge selection

Edge selection

7. Enable the real distance, if applicable.

Real distance  Off

8. For **advanced setup**, adjust and enable the following settings:

Advanced setup

Edge threshold hysteresis  
 

Check right angle distance  On  
 

Check euclidean distance  On  
 

- Edge threshold setup
- Check right angle distance
- Check Euclidean distance

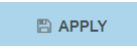
9. When all adjustments are finalized, click the  button to confirm.

10. Then, check the results in the Inspection result window.



If one of the 2D Measurement regions is removed, then the second region will also be removed automatically.

## 4 GETTING STARTED

---

### 4.11.3 Pattern verifier

#### Foreground color



- Dark – dark structures on a light background are segmented.
- Light – light structures on a light background are segmented.

#### Minimum match

Inspects the similarities between the inspected area and its pattern.

- Local threshold mask size – assist the segmentation to extract a foreground from an input image.

#### Threshold

Segments an image that filters out any pixels with undesirable intensity.

#### Threshold hysteresis

The hysteresis mode performs a hysteresis threshold operation on an image. Any pixel above the upper threshold will turn to white. The surrounding pixels are then searched recursively. If the values are greater than the lower threshold they will also turn to white, producing many fewer specks of white in the resulting image.

#### Minimum error area

This feature will filter-out lesser area value (lower than the specified minimum error area) of non-matching region and separated region. These regions will not be included when computing Match [%].



Please be informed that you must be a “Service” level user in order to access the Pattern verification.

---



---

Please be informed that any changes applied will only be saved, if you have re-activated the  APPLY button.

All inspection regions will be displayed after image processing is finished with a short delay.

---

**Proceed as follows:**

- 1. Select the applicable Inspection to Add.

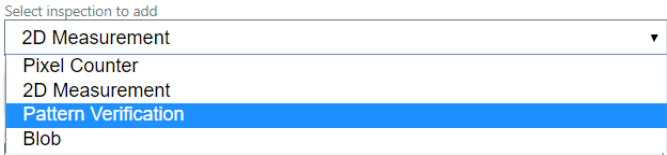

- 2. Then, click the **+ ADD INSPECTION** button.

- 3. Dark green colored region shape will appear.



- 4. Place the Pattern verification polygon frame on the desired ROI to check the correct pattern from the original sample for comparison.



- 5. Set the necessary adjustments:

- Foreground color
  - Dark
  - Light



## 4 GETTING STARTED

- Minimum match



- Threshold



- Threshold hysteresis



- Minimum error area



Adjust the local threshold, according to the desired highlighted pixel.

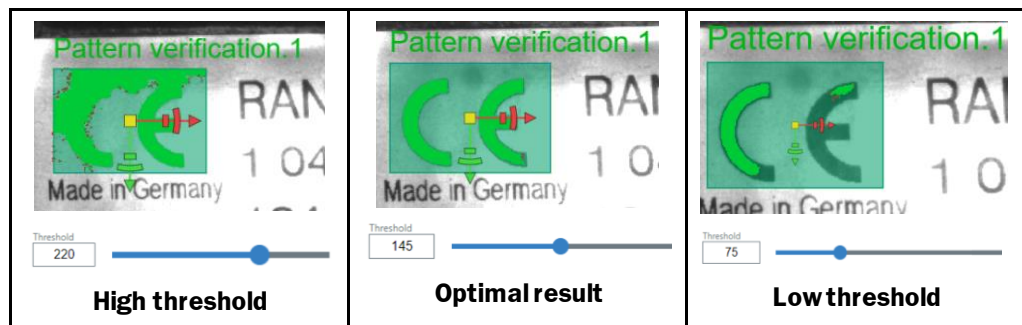

Figure 83 Threshold - Pattern verification

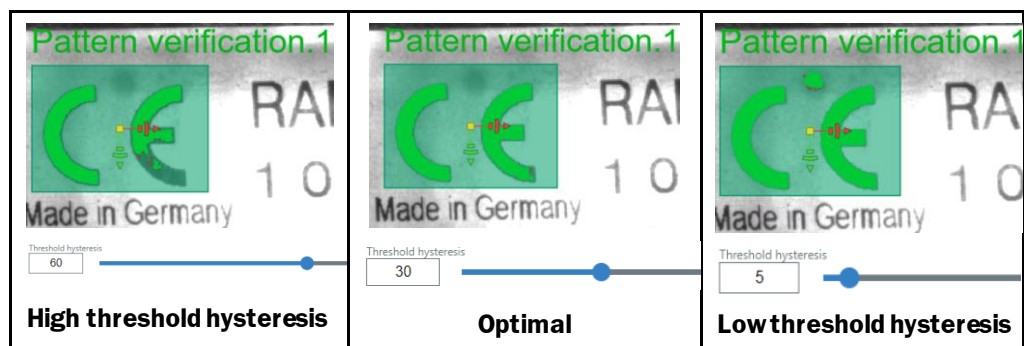
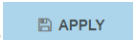
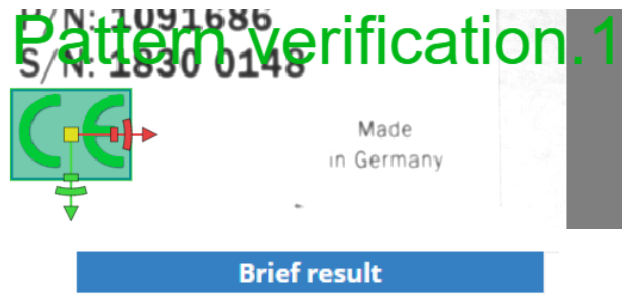

Figure 84 Threshold hysteresis - Pattern verification

8. When all adjustments are finalized, click the  button to confirm.
9. Afterwards, you can check the results in the Inspection result window.



Pattern Verification.1: Match: **100.0%**





Taught sample	Sample that does not match the original character
 <p>Pattern Verification.1: Match: <b>100.0%</b></p>	<p>P/N: 1091686 S/N: 1830 01</p> 
 <p>Pattern Verification.1: Match: <b>100.0%</b></p>	 <p>Pattern Verification.1: Match: <b>57.0%</b></p>

Figure 85 Match - Pattern verification

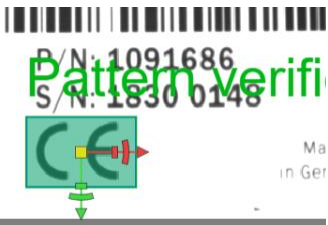

In some cases, the match can be lower than 100% right after teaching the reference. Such behavior is normal which is caused by the outer regions of the object, and if the match is not significantly lower, then it will not influence the functionality of the inspection.

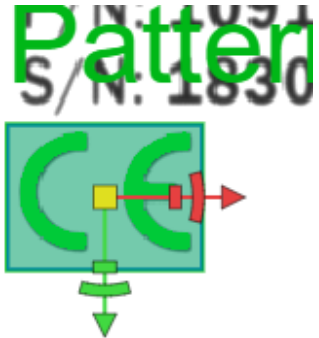
## 4 GETTING STARTED

---

### 4.11.4 Blob

The camera identifies chunks of pixels with the similar gray values. Using this inspection, you can verify the number of objects with specified width, height, area, and/or send their position to external device.

#### Manual threshold

Sets the threshold in selecting the pixels, depending on their intensity (brightness). According to the selected Foreground color option, the lighter/darker pixels than the threshold will be selected.

#### Local threshold

The local threshold segments an image to smaller parts and adjust the threshold for each segment dynamically.

#### Auto threshold

The auto threshold segments an image determined from its histogram. The threshold level automatically adjusts the contrast between the objects and the background.

#### Foreground color

- Dark  
Dark structures on a light background are selected.



- Light  
Light structures on a light background are selected.



**Area, width, and height**

Blob feature that filters the chunks of pixels according to set parameters.

**Number of blobs**

The expected count/number of blobs.

**Fill holes**

When this feature is enabled, the blob will fill the space inside the highlighted chunk of pixels.

**Allow border blobs**

When this feature is disabled, it removes all blobs touching the border of the inspection region (polygon).

When enabled, the blobs extending from the border of the region will also be processed.

**Ascending/Descending**

The detailed result can be documented/stored via output format or csv file. All Found blobs can be sorted in an ascending/descending manner, according to:

- Area
- Height
- Width
- Position row
- Position column



Please be informed that you must be a “Service” level user in order to access the Blob settings.



Please be informed that any changes applied will only be saved, if you have re-activated the  button.

All inspection regions will be displayed after image processing is finished with a short delay.

## 4 GETTING STARTED

---

### Proceed as follows:

1. Select the applicable Inspection to Add.

Select inspection to add

2D Measurement	▼
Pixel Counter	
2D Measurement	
Pattern Verification	
<b>Blob</b>	

2. Then, click the **+ ADD INSPECTION** button.

3. Purple region shape will appear.

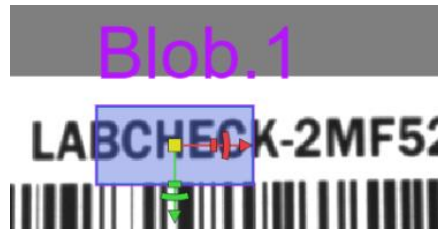

4. Place the Blob inspection region shape on the desired ROI.

5. Select the threshold type:

- Auto threshold
- Local threshold
- Manual threshold

6. Select the foreground color.

- Dark
- Light

7. Adjust the following settings:

- Area

Area

10	●	640
----	---	-----

- Height

Height

10	●	30
----	---	----

- Width

Width

10	●	28
----	---	----

- Number of blobs

Number of blobs

1	●	15
---	---	----



8. Enable the following settings, if applicable:

- Fill holes



- Allow border blobs



The detailed result can be documented/stored via output format or csv file [4.12.4 Save results to file. csv file](#). All found/identified blobs can be sorted in an ascending/descending manner, according to:

Sort by

Area

Ascending Descending

Area	Position row
Height	Position column
Width	

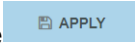
9. When all settings are finalized, click the  button to confirm changes.

10. Afterwards, check the results in the Inspection result window.

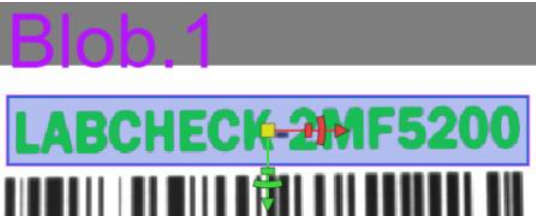

## 4 GETTING STARTED

### 4.12 FTP setup

#### 4.12.1 FTP client settings

FTP is a standard open protocol that is widely used to transport and receive files and stores images. FTP uses ports for communications, including encryption to protect the information being received and sent.

The FTP is used to upload camera images, and/or results in a text form to remote server.

**SICK**  
FTP

InspectorP652 Flex  
3.1.0.28R  
16480135

Device

- Run
- Image
- Object Locator
- OCR
- 1D/2D Code
- Other Inspections
- FTP**
- Digital I/O
- Communication

Status bar  
Save results to .csv file enabled

**APPLY**

### FTP Client setting

How to save result  
Disabled

Save result to .csv file **On**

CSV separator  
;

**EXPORT RESULTS TO .CSV FILE IMMEDIATELY**

IP address  
192.168.0.2

Port  
65535

Username  
anonymous

Password  
.....

Figure 86 FTP settings



Please be informed that you must be a “Service” level user in order to access the FTP setup settings.



Please be informed that any changes applied will only be saved, if you have re-activated the **APPLY** button.

All inspection regions will be displayed after image processing is finished with a short delay.

**Proceed as follows:**

1. Select the following features on how to save results, if applicable:
  - Disabled
  - Save only when inspection fails
  - Save images and results
  - Save results to .csv file



---

You may click the  button whenever ready.

---

2. Set the IP address of the FTP server and the login information:
  - IP address
  - Username
  - Port
  - Password

## 4 GETTING STARTED

---

### 4.12.2 How to save results

You can select from this feature of what type of image will be sent via the FTP.

How to save result

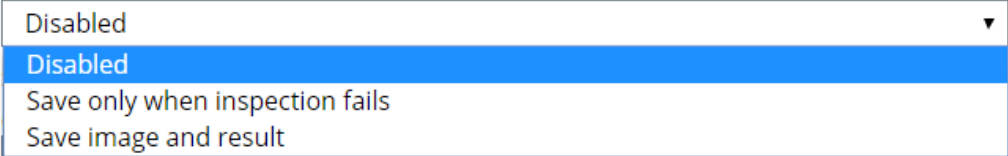

The image shows a dropdown menu titled "How to save result". The menu is open, showing three options: "Disabled" (which is highlighted in blue), "Save only when inspection fails", and "Save image and result".

Figure 87 How to save results



---

Saving images only when inspection fails is highly recommended due to the less bandwidth usage than storing all images.

---

### 4.12.3 Draw results to image

The stored images will contain the draw inspection results.

### 4.12.4 Save results to file. csv file

The database is exported into a single csv file. The data fields are separated by a predefined separator, most usually with a semicolon. The separators are required so that the fields correspond from row to row. The CSV file is sent every 100<sup>th</sup> trigger, when a job is changed or when a number of regions were changed.

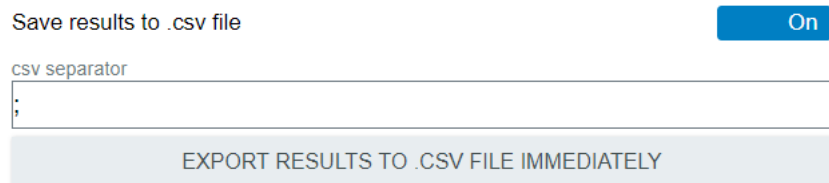

The image shows a control panel for saving results to a CSV file. It includes a toggle switch labeled "Save results to .csv file" which is currently turned "On". Below this is a text input field labeled "csv separator" containing a semicolon (;). At the bottom of the panel is a button labeled "EXPORT RESULTS TO .CSV FILE IMMEDIATELY".

Figure 88 CSV separator



---

If the fields of data in your **CSV** file contain commas, you can protect them by enclosing those data fields in double-quotes ("). The commas that are part of your data will then be kept separate from the commas which delimit the fields themselves.

If your fields contain double-quotes as part of their data, the internal quotation marks need to be doubled so they can be interpreted correctly.

---

**4.12.5 IP address**

IP address of FTP server, where the data is to be saved. The Ethernet address is set manually via the IP address parameter.

**4.12.6 Port**

The IP port parameter can be used to adjust the port number for the Ethernet host interface, in-line with the connected PC. The "Port" setting specifies on which port the FTP server complies for the new control connections.

**4.12.7 Username**

The "Username" setting specifies the account name used when logging into the FTP server. The server administrator configures the user accounts.

**4.12.8 Password**

The "Password" settings specifies the password of the account to be used when logging into the FTP server.

### 4.13 Digital Inputs/ Outputs



There are no possibilities to switch the jobs via digital input. Switching jobs is only possible via command or by using the auto job switching function. Please find Allowed Messages in [subsection Error! Reference source not found. of the Command list](#).

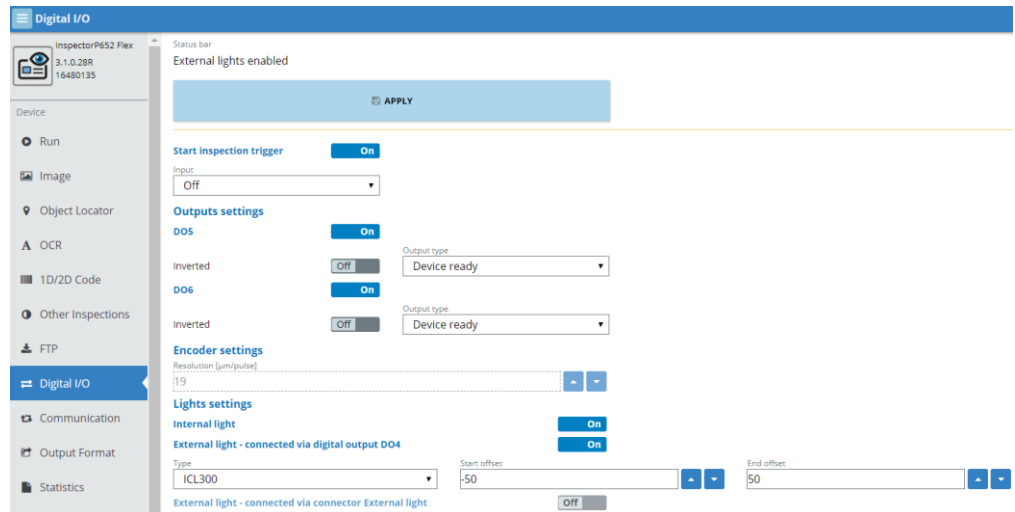

Figure 89 Inputs/Outputs Settings

#### 4.13.1 Apply

Saves the set parameterization to the camera memory.

4.13.2 Start inspection trigger settings

You may set the delay of the input signal (trigger), as well as the output duration.

Inspection trigger input

The digital input, which is a source of a trigger signal (Input wire). Changing the signal level (rising or falling edge) results in one image acquirement.



Switching this button to off position will ignore all incoming trigger signals.

The trigger default setting is set to Digital in 1, it can also be set to off.

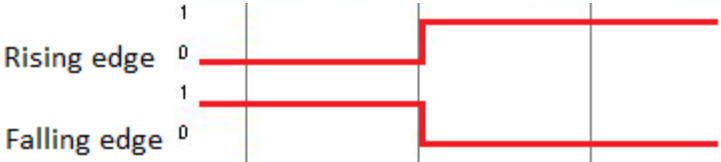

Figure 90 Trigger input

- **Activation type**  
Activation type can be set to:
  - ▶ Rising edge
  - ▶ Falling edge



Figure 91 Trigger activation type



## 4 GETTING STARTED

---

### 4.13.3 Output settings

#### Output types

All outputs can be configured in three behaviors:

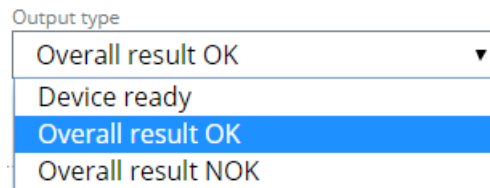

Figure 92 Output type

- **Device ready** – Device ready signal will be active when the camera is turned on. The device ready signal will be inactive, when the device is saving the settings during job switching, and during camera booting.
- **OK signal** – Ok signal is turned on, when all inspection passed.
- **NOK signal** - Ok signal is turned on, when all inspection failed.



**Inverted**

Invert output logic

When the Inverted parameter is set to ON, then Logical “true” means 0 V, and logical “false” means 24 V.

**Enabled**

Output activated

**Inverted activation type**

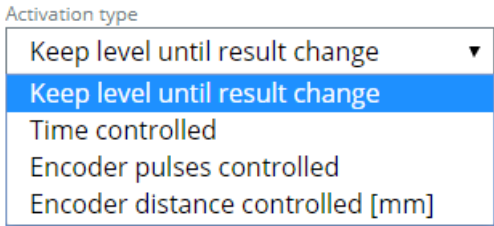

- **New result** – OK/NOK signal is activated when new result is computed.
- **Time-Controlled** – Output activated. Start offset must be greater than the camera execution time.

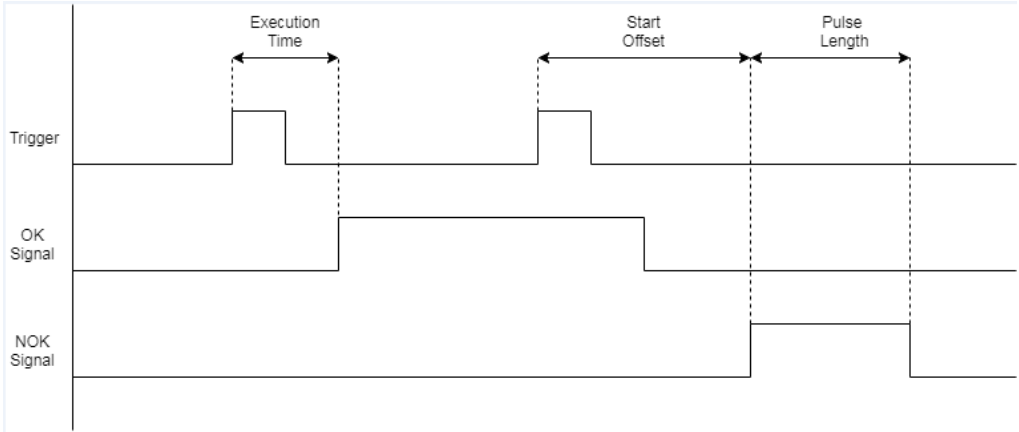

Figure 93 Time diagram

The time diagram demonstrates two trigger signals. Where first part shows OK signal with Activation type – “New results”, and second part NOK with Time-controlled activation type.



There is a possibility to set the delay of the trigger signal or the delay of the output signal in millimeters.

When the encoder delay is selected, the D03 is automatically deactivated, thus there will be only two outputs left to be utilized.

**Start offset** – offset from the trigger, has to be set higher than the processing time (it is not possible to output the result before the inspection ends).

**Pulse length** – set the duration of the signal.

### Setting the output delay in pulses

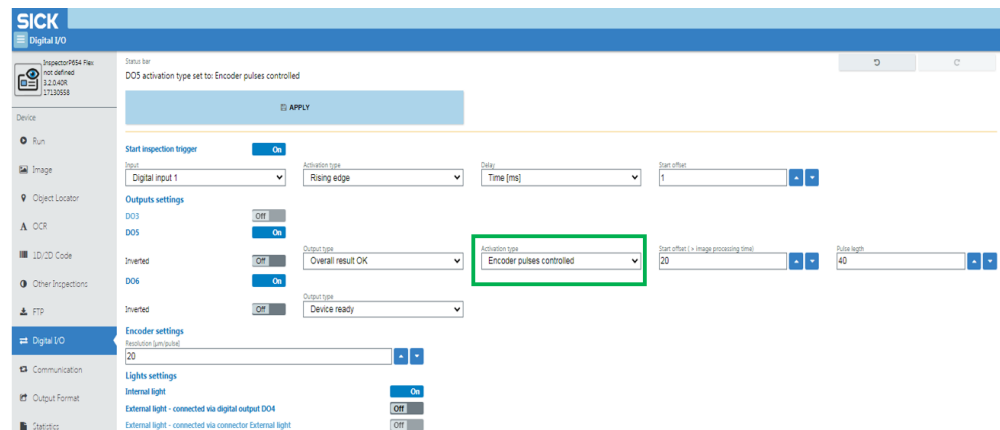

Figure 94 D05 activation type



When setting the following parameters in **pulses**, there is no need to set the correct encoder resolution.

## Setting the output delays in millimeters

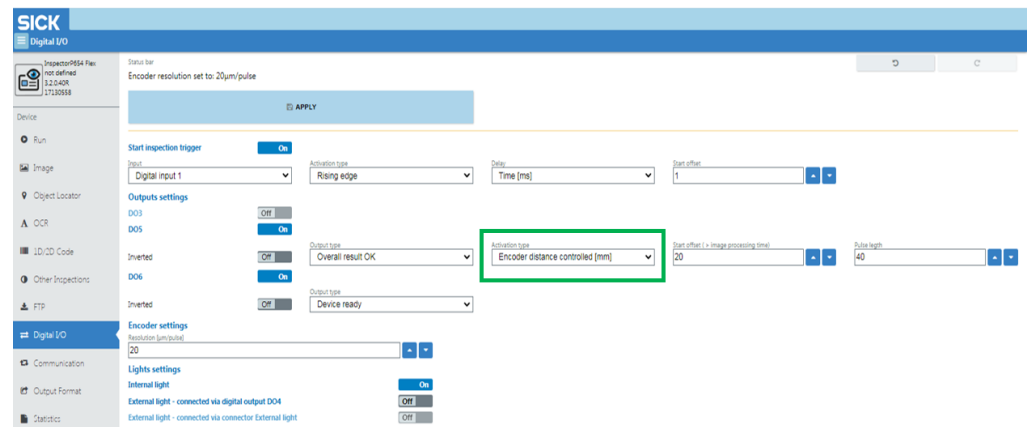

Figure 95 DO delays in millimeters



When set in **millimeters**, the encoder resolution must be precisely set.

### 4.13.4 Light settings

Used to select which illumination is used.

**Internal light** – Driven by the camera itself, but can be disabled when not in use.

**External light via connector External light** – Enabled only for LBC632 and LBC631.

**External light via DI4** - Enabled for Label Checker 621/63x/642/65x



The settings must be adjusted when adding an external light.

## 4 GETTING STARTED

### 4.13.5 How to set up the Input/Output settings



Please be informed that you must be a “Service” level user in order to access the Input/Output settings.



Please be informed that any changes applied will only be saved, if you have re-activated the  button.

All inspection regions will be displayed after image processing is finished with a short delay.

#### Proceed as follows:

##### 1. Enable the start inspection trigger settings:

- Select digital input.

Input

Digital input 1	▼
Digital input 1	
Off	

- Select activation type.

Activation type

Rising edge	▼
Rising edge	
Falling edge	

- Delay

Delay

No delay	▼
No delay	
Time [ms]	
Encoder pulses	

- Start offset

Start offset

2	▲	▼
---	---	---

2. Select the applicable output settings:

- D05/D06
  - Output type

Output type

Device ready	▼
Device ready	
Overall result OK	
Overall result NOK	

- Enable/Disable Inverted/

Inverted  Off

3. Adjust the encoder settings, if applicable.

Encoder settings

Resolution [µm/pulse]

19	▲	▼
----	---	---

4. Switch on/off the following light settings, if applicable:

- Internal light

Internal light  On

- External light via D04

External light - connected via digital output D04  On

Type	Start offset	End offset
ICL300	-50	50

- External light via connector external light (only available for LBC63x).

External light - connected via connector External light  Off

## 4 GETTING STARTED

5. Adjust the following parameters, if applicable:

- Type

Type  
ICL300

- Start offset in  $\mu$ s.

Start offset  
-50

- End offset in  $\mu$ s

End offset  
50

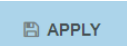

If the exposure is set to 500 ms, then the light will be on for 500,1 ms.

6. When all adjustments are final, click the  button to save updated changes.

### 4.13.6 DI/DO for LBC621/LBC63x/LBC64x/LBC65x

CAMERA	CDB650
DO 3 (also used for encoder)	20   RES/ OUT 1
DO 4 (also used for external illumination)	21   RES/ OUT 3
DO 5	50   RES/ OUT 3
DO 6	51   RES/ OUT 4
DI 1 (used for trigger)	10   SENS/ IN 1

### 4.14 Font teaching

This feature is used to teach-in/create new fonts.

#### 4.14.1 Create/ modify new/existing alphabets

You may create or change a new or existing font by inserting the font's name file. Retrain with new font samples.

The operating entity collects new characters images and then starts training the Label Checker application – it is trained from beginning.

#### 4.14.2 Font teaching settings

All the settings are similar to OCR settings that can be found in OCR/OCV tab. Please refer to [subsection 4.8 of the OCR/OCV tab](#).

#### 4.14.3 How to create font teaching



---

Please be informed that you must be a “Service” level user in order to access on how to create Font teaching.

---



---

Please be informed that any changes applied will only be saved, if you have re-activated the  button.

All inspection regions will be displayed after image processing is finished with a short delay.

---



---

The Font teaching features have similar functions as the OCR/OCV tab, such as print type, Thresholding method, image filters.

---

## 4 GETTING STARTED

---

### Proceed as follows:

1. You must create an image first via the Run tab [subsection 4.5.1](#) and save the reference image via Image tab found on [subsection 4.6.1](#)
2. Once you have saved the reference image, you can open the Font teaching tab.
3. Click  to create the image. Or press “Load Image” button and select one of the reference images from the already existing jobs. When the desired reference image is not able to load, then select a different reference image, afterwards reselect the desired one.

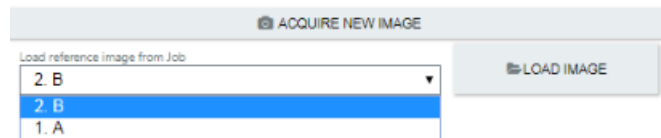

4. Select **Create new font**
5. Fill in the name for the new font.

Name of new font

Test\_1

6. Then, Click **NEXT >**

7. Select the region shape.

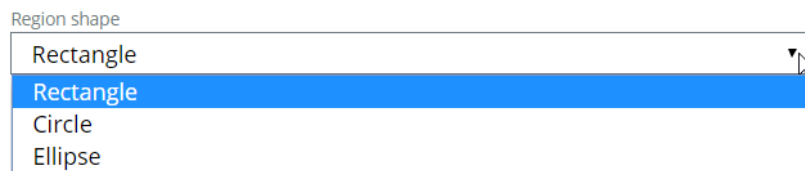

8. Place the region shape on the desired ROI.

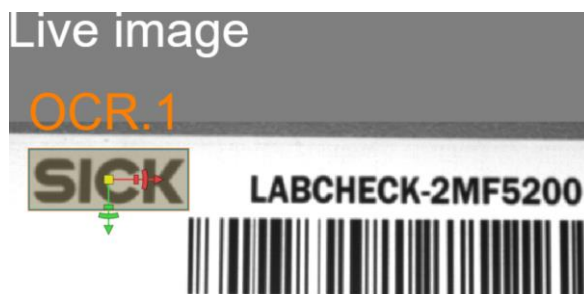



9. Set the necessary adjustments.

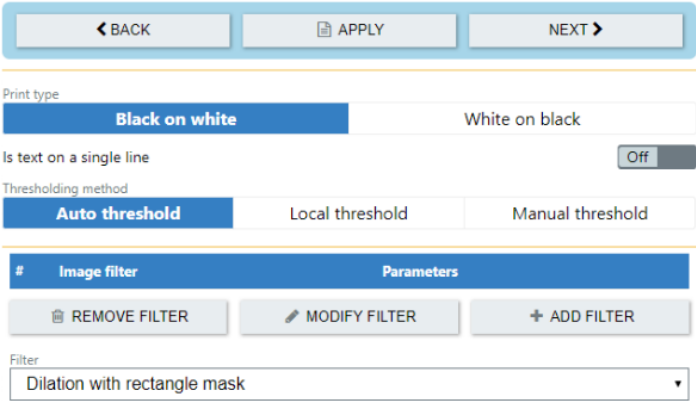

10. Afterwards click **APPLY** and wait for the text parsing process (ORC font teaching).

**i** Check if all characters are fully highlighted and each adjacent character has a different color.

Text segmentation was successfully finished. 4 characters found.

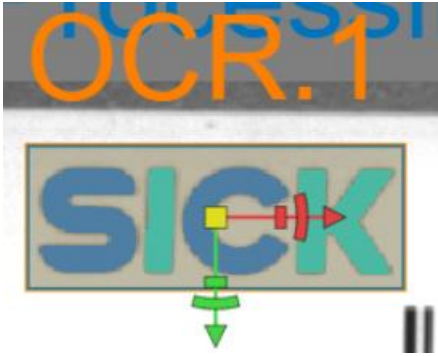

11. Then click **NEXT >**

## 4 GETTING STARTED

12. Wait until the desired text segmentation is successful.

Fill in highlighted characters here

SICK

Was characters segmentation successful? If yes, fill in, what characters are highlighted on the image in the same order and click button 'Next'.



The Label Checker figures out the text. Please modify the results if necessary.

13. Then click **NEXT >** button to confirm the new character font, or **< BACK** button in case you need to redo the process again.

14. If you would like to add another character font, you can select “teach another characters”, otherwise select “Save & Finish” to generate the created font.

To teach and add new characters to the selected font click on button 'Add new characters'. To finish the teaching process and save all changes in the the selected font click on button 'Save & finish'. Only after you have finished the teaching will be all new changes available in OCR/OCV reading.



15. Now, you can go to OCR/OCV tab and you will see that the newly created font will be available.

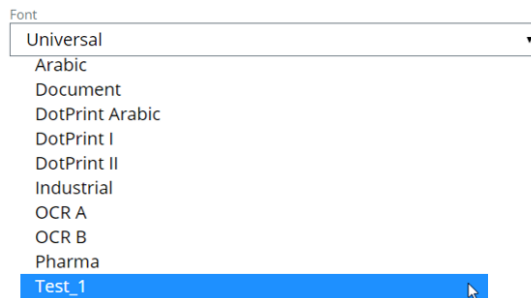

Your newly created/saved character font will be found in the OCR/OCV font selections.



You cannot add any character to pre-build fonts. Such setting only applies for created customized fonts.

4.15 Communication

The communication flow chart:

- 1. When the Label Checker receives invalid data command from enabled interface, the camera confirms each invalid command with “NOK” response.

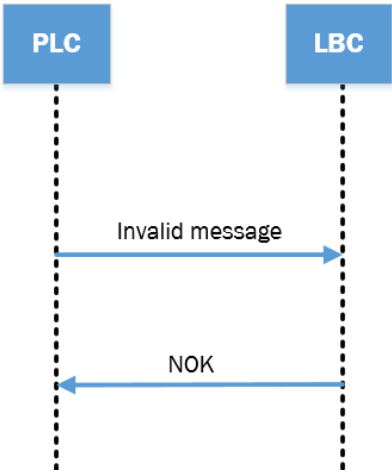

Figure 96 LBC receiving invalid data command

- 2. Commands JOB and EXP are executed and after execution the camera sends a command with “ACK” response.

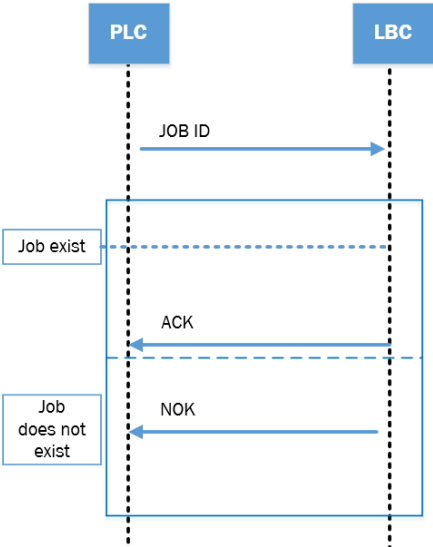

Figure 97 Commands JOB and EXP are executed

- When the Trigger command is received camera send back „ACK“, then triggers the image acquisition.

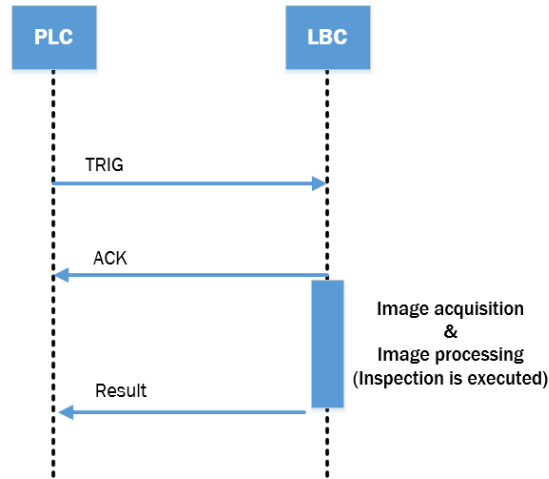

Figure 98 Trigger command

- The camera sends the result string (built in output format designer) to all enabled communication interfaces immediately after the inspection is achieved (Image processing is completed).

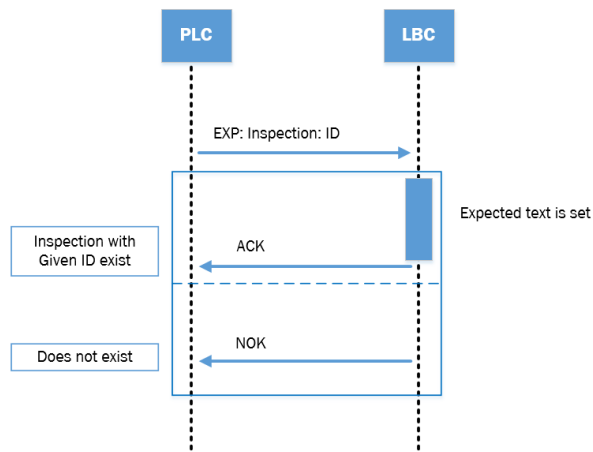

Figure 99 Expected text

This communication flow chart is similar with the Ethernet communication (UDP TCP/IP), as well as the serial communications. Please find [subsection 4.15.5 of the Ethernet/IP control bits behavior](#).



All communication setting is related to the connected control system/PLC/PC.

4.15.1 Command list

Table 3 Allowed messages (used without brackets “[ ]”)

ALLOWED MESSAGES	
JOB[X]	Select Job where [X] is Job number.
EXP	EXP:[Inspection nameshort cut]:[inspection ID]:[expected text] Inspection name short cut: For 1D code: <b>C1D</b> For 2D code: <b>C2D</b> For OCV: <b>OCV</b> For OCR: <b>OCR</b>
TRIG	Triggers the camera
FNM	FNM:[CustomerFileNameWithoutDotAndFileType] Sets desired filename for image sent to FTP server.

**Example:**

There are 2 jobs in the camera, A and B:  
 Job A has 2 inspections set, OCR.1 and OCR.2. Each of these inspection has an enabled OCV.  
 Job B has no inspections set. The FTP function and UDP communication is enabled.

**The following are the syntax example, on how to use allowed messages:**

**Choose the job:**

JOB2 - choose job B  
 JOB1 - choose job A

**Set the expected text for the current chosen job (job A):**

EXP:OCV:1:test (1 - number of the inspection in job, in this case OCR.1)  
 EXP:OCV:2:test (sets the expected text “test” for the second OCV inspection OCR.2)

### Set desired filename for the image file sent via FTP:

FNM:test (sets the filename to “test.\*”, where \* is chosen in the FTP tab)

### Triggering the camera:

TRIG - triggers the camera and executes the inspection and FTP transfer

### Reply:

ACK/NOK - reply on the message - ACK if message was valid or NOK if message sample has a wrong syntax or unknown

### Communication example via UDP:

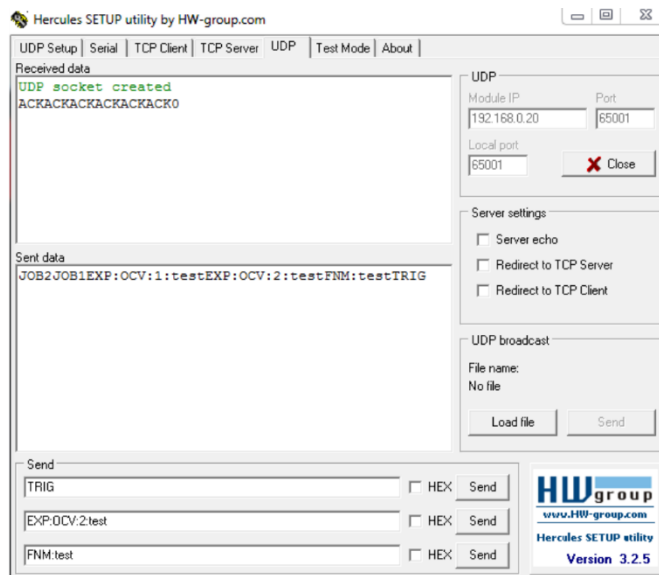

Figure 100 Communication via UDP

### Communication settings:

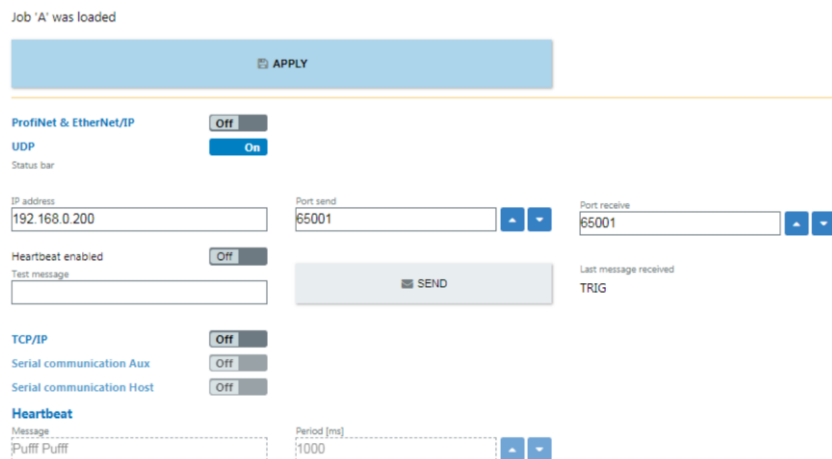

Figure 101 Communication settings

4.15.2 UDP, TCP/IP and serial

UDP

UDP **On**  
Status bar

IP address: 10.0.0.2  
Port: 1001

Heartbeat enabled: Off

Test message:

SEND

Last message received

Figure 102 UDP

TCP/IP

TCP/IP **On**  
Status bar

Server/Client: Server  
Port: 2120  
Max. connections: 1

Rx start:  Rx stop:   
Tx start:  Tx stop:

Heartbeat enabled: Off

Test message:

SEND

Last message received

Figure 103 TCP/IP

The Label Checker utilizes the following communication:

- Serial AUX communication

Serial communication Aux **On**  
Status bar

Type: RS232  
Baudrate: 9600  
Data bits: 8  
Stop bits: 1

Rx start: 02 Rx stop: 03  
Tx start: 02 Tx stop: 03  
Parity: None

Heartbeat enabled: Off

Test message:

SEND

Last message received

Figure 104 Serial AUX communication

- Serial Host communication

Figure 105 Serial Host communication

### Basic serial parameters

Table 4 Basic serial parameters

Type	RS-232
Baud rate	9600
Parity	none
Data bits	8
Rx Start	2
Rx Stop	3
Tx Start	2
TX Stop	3
Stop Bits	1



The values for Rx Start, Rx Stop, TX Start, and TX Stop parameters, 2 means the ASCII values of characters (2 means character “STX” and 3 “ETX”).



Table 5 Communication

Communication		
UDP	IP address	Host IP address
	Port	For communication, same as camera setting and host.
	Test message	Test message what can be sent to host.
TCP/IP	Server - (one or more) Client communication. Guarantees delivery, ordering, or duplication.	
	IP address	Client is responsible to set the IP Address to their server.
	Port	Port for communication; The same for server and all Clients.
	Maximum connections	Only Server can set it, maximum number of connected Clients. Any other client cannot be connected.
	Rx Start, Rx End, Tx Start, Tx End	Message framing
	Test message	Server sends test message to all Clients, or any Client to Server (Not Client to another Client).
Serial communication	Send data, only 1 bit at a time.	
	Baud rate	Common measure of the speed of communication over a data channel.
	Parity	Parity type - None, Odd, Even, Mark, Space
	Data bits	Number of data bits
	Stop bits	Number of bits
	Rx Start, Rx End, Tx Start, Tx End	Message framing

## 4 GETTING STARTED

---

	Test message	Test message
Heart beat	The heart beat periodically sends a message from the camera to the control system. It then enables the destination to identify if and when the camera fails or no longer available.	
	Period	Test message is sent after every real time at a given interval period.
	Message	Used only for Heartbeat

4.15.3 PROFINET

GSDML file can be found here:

[https://supportportal.sick.com/Product\\_notes/fieldbus-kit-inspectorp6xx/](https://supportportal.sick.com/Product_notes/fieldbus-kit-inspectorp6xx/)

You may also find communication examples with S7-300 (Step7) and S7-1200/1500 (TIA):

<https://apppool.cloud.sick.com/publications/9e83965a-b671-43d8-af2a-34437d38f868>

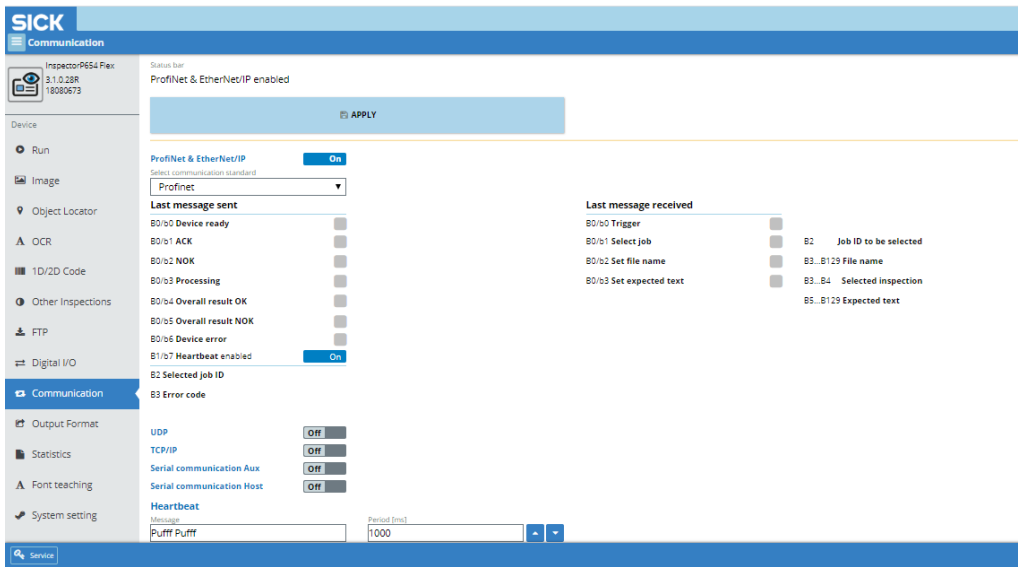

Figure 106 Communication



Current versions of Label Checker already support PROFINET onboard and the use of the CDF module is no longer needed nor recommended. Therefore, use the following instructions only if you need to use PROFINET via the CDF module.

The superior system communication utilizes a Profibus/Profinet, which you may use the CDF600 device.

The CDF600 communicates with the Label Checker, utilizing RS-232 protocol. In order to set up this protocol, it must be activated using the Communication tab.



The camera must be rebooted after enabling/disabling the PROFINET communication. The reboot camera button will immediately appear and must be selected.

**Data transmitted from PLC to Label Checker**

Byte no.	Bit structure								Type	
	Bit 7	Bit 6	Bit 5	Bit 4	Bit 3	Bit 2	Bit 1	Bit 0		
0	N/A	N/A	N/A	N/A	Set expected text	Set file name	Change job	Trigger	Bits	Control bits
1	N/A	N/A	N/A	N/A	N/A	N/A	N/A	N/A	Bits	
0	Selected Job ID								Byte - number 1 - 255	Data bytes
1	Other commands data - Char 1								Byte - one char	
2	Other commands data - Char 2								Byte - one char	
3	Other commands data - Char 3								Byte - one char	
...	...								...	
127	Other commands data - Char 127								Byte - one char	

**Bits**

Trigger bit	Trigger the image acquisition and all inspections processing.
Change Job bit	Enable selecting a required job
Set file name	Set name of file which is saved on the FTP server (image, results)
Set expected text	Set expected text of selected inspection – only OCR, 1D Code and 2D Code supported. Adjust expected text of currently selected job. Change “Reading type” option from “Character recognition” to “Character verification”.

**Bytes/ Data when setting expected text**

Byte number	Byte content description	Data type	Example	
			Char in ASCII representation	Hexadecimal code
Byte 0	Selected job ID – this takes no effect when setting expected text	Byte - number 1 - 255	‘SOH’	0x 01
Byte 1				
Byte 2				
Byte 3				
Byte 4				
Byte 5				
Byte 6				
...				
Byte 127				

**Bytes/ Data when setting FTP file name**

Byte number	Byte content description	Data type	Example	
			Char	Hexadecimal code
Byte 0	Selected job ID - this takes no effect when setting expected text	Byte - number 0 - 255	'SOH'	0 x 01
Byte 1	Used to select inspection type char 'c' = 1D, char 'o' = OCR/OCV, char 'd' = 2D code	x	'c'	0 x 63
Byte 2	Used to select inspection ID	Byte - number 1-255	'EXT'	0 x 03
Byte 3	Expected char 1	Char	'S'	0 x 53
Byte 4	Expected char 2	Char	'I'	0 x 49
Byte 5	Expected char 3	Char	'C'	0 x 43
Byte 6	Expected char 4	Char	'K'	0 x 4B
...	...	...		
Byte 127	Expected text char 125	Char		

**Byte / Data when setting FTP file name**

Byte number	Byte content description	Data type	Example	
			Char	Hexadecimal code
Byte -	Selected job ID - this takes no effect when setting the name of file	Byte - number 1 - 255	'SOH'	0 x 01
Byte 1	Name of file to be saved on FTP server char 1	Char	'S'	0 x 53
Byte 2	Name of file to be saved on FTP server char 2	Char	'I'	0 x 49
Byte 3	Name of file to be saved on FTP server char 3	Char	'C'	0 x 43
Byte 4	Name of file to be saved on FTP server char 4	Char	'K'	0 x 4B
...	...	...		
Byte 127	Name of file to be saved on FTP server char 127	Char		

## Data transmitted from Label Checker to PLC

Byte no.	Bit structure								Type	
	Bit 7	Bit 6	Bit 5	Bit 4	Bit 3	Bit 2	Bit 1	Bit 0		
0	N/A	Device error	Overall result NOK	Overall result OK	Processing	NOK	ACK	Device ready	Bits	Control bits
1	Heart beat	N/A	N/A	N/A	N/A	N/A	N/A	N/A	Bits	
0	Selected Job ID								Byte - number 1 - 255	Data bytes
1	Error Code								Byte - one char	
2	Output string designed in "Output Format" tab on Label Checker web page - Char 1								Byte - one char	
3	Output string designed in "Output Format" tab on Label Checker web page - Char 2								Byte - one char	
...	...								...	
127	Output string designed in "Output Format" tab on Label Checker web page - Char 126								Byte - one char	

### Bits

Device Ready bit	The camera is ready. Command can be sent to a camera.
ACK bit	If message sent from PLC to Label Checker was valid.
NOK bit	If message sent from PLC to Label Checker was invalid.
Processing bit	Image processing is running.
Overall result OK bit	All inspections passed.
Overall result NOK bit	At least one inspection failed.
Device Error bit	An error occurred - caused by invalid command sent from PLC to Label Checker.

### Byte/ Data

Selected Job Id	Currently selected job
Error Code	A root cause of an error state
Output string designed in "Output Format" tab on Label Checker web page.	The result of selected inspections in required format.

4.15.4 Ethernet/IP

**EDS file can be found here:**

[https://supportportal.sick.com/Product\\_notes/fieldbus-kit-inspectorp6xx/](https://supportportal.sick.com/Product_notes/fieldbus-kit-inspectorp6xx/)

You may also find communication examples with Allen-Bradley PLC:

<https://appool.cloud.sick.com/publications/9e83965a-b671-43d8-af2a-34437d38f868>

**Data transmitted from PLC to Label Checker**

Byte no.	Bit structure								Type	
	Bit 7	Bit 6	Bit 5	Bit 4	Bit 3	Bit 2	Bit 1	Bit 0		
0	-	-	-	-					Bits	Control bits
1	-	-	-	-	Set expected text	Set file name	Change job	Trigger	Bits	
2	Job ID to be selected								Byte - number 0 - 255	Data bytes
3	Other commands data -Byte 0								Byte - one char	
4	Other commands data - Byte 1								Byte - one char	
5	Other command data - Byte 2								Byte - one char	
...	...								...	
129-	Other command - Byte 26								Byte - one char	

## 4 GETTING STARTED

### Bits

Trigger bits	Triggers the image acquisition and all inspection processing.
Change job bit	Enable selecting a required job
Set file name	Set name of file which saved on the FTP server (image, results)
Set expected text	Set expected text of selected inspection – only OCR, 1D Code and 2D code supported. Adjust expected text of currently selected job. Change “reading type” option from “character recognition” to “Character verification”.

### Bytes/Data when setting expected text

Byte number	Byte content description	Data type	Example	
			Char	Hexadecimal code
Byte 2	Id of job to be selected – this takes no effect when setting the expected text	Byte – number 0 -255	'SOH'	0 x 01
Byte 3	Used to select inspection type : Char 'c' = 1D code Char 'o' = OCR/OCV Char 'd' = 2D code	x	'c'	0 x 63
Byte 4	Used to select inspection ID	Byte number – 0 - 255	'ETX'	0 x 03
Byte 5	Expected text char 1	Char	'S'	0 x 53
Byte 6	Expected text char 2	Char	'I'	0 x 49
Byte 7	Expected text char 3	Char	'C'	0 x 43
Byte 8	Expected text char 4	Char	'K'	0 x 4B
...		...		
Byte 129	Expected text char 127	Char		



**Data transmitted from Label Checker to PLC**

Byte no.	Bit structure								Type	
	Bit 7	Bit 6	Bit 5	Bit 4	Bit 3	Bit 2	Bit 1	Bit 0		
0	Heart beat	-	-	-	-	-	-	-	Bits	Control bits
1	-	Device Error	Overall results NOK	Overall results OK	Processing	NOK	ACK	Device ready	Bits	
2	Selected job ID								Byte - number 0 - 255	Data bytes
3	Error code								Byte - one char	
4	Output strings designed in "Output Format" tab on Label Checker web page - Byte 0								Byte - one char	
5	Output strings designed in "Output Format" tab on Label Checker web page - Byte 1								Byte - one char	
...	...								...	
129	Output string designed in "Output Format" tab on Label Checker web page - Byte 125								Byte - one char	

**Bits**

Device Ready bit	The camera is ready. Command can be sent to a camera.
ACK bit	If message sent from the PLC to Label Checker was valid
NOK bit	If message sent from the PLC to Label Checker was invalid
Processing bit	Image processing is running
Overall result OK bit	Image processing is running
Overall result NOK bit	At least one inspection failed
Device Error bit	An error occurred - caused by invalid command sent from PLC to Label Checker

## 4 GETTING STARTED

### Bytes/Data

Selected job ID	Currently selected job
Error code	Root cause of an error state
Output string designed in "Output format" tab on Label Checker web page	The result of selected inspections in required format.

#### 4.15.5 PROFINET and Ethernet/IP Control bits behavior

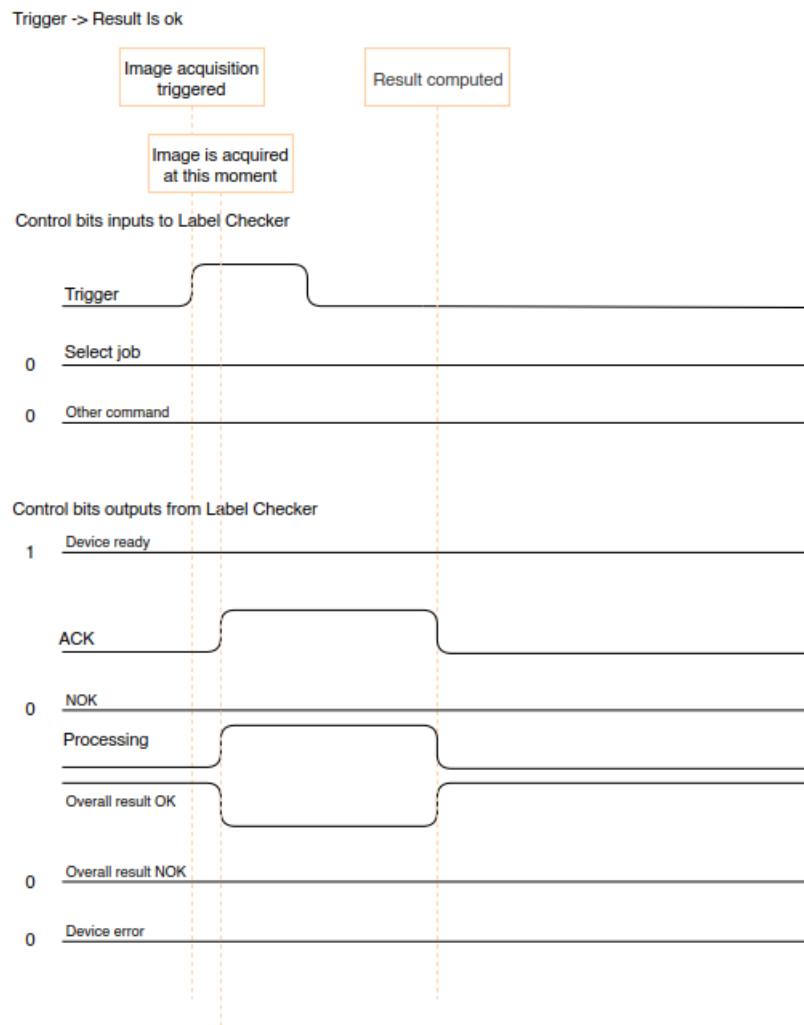

Figure 107 Trigger result OK

Trigger -> Result is NOK

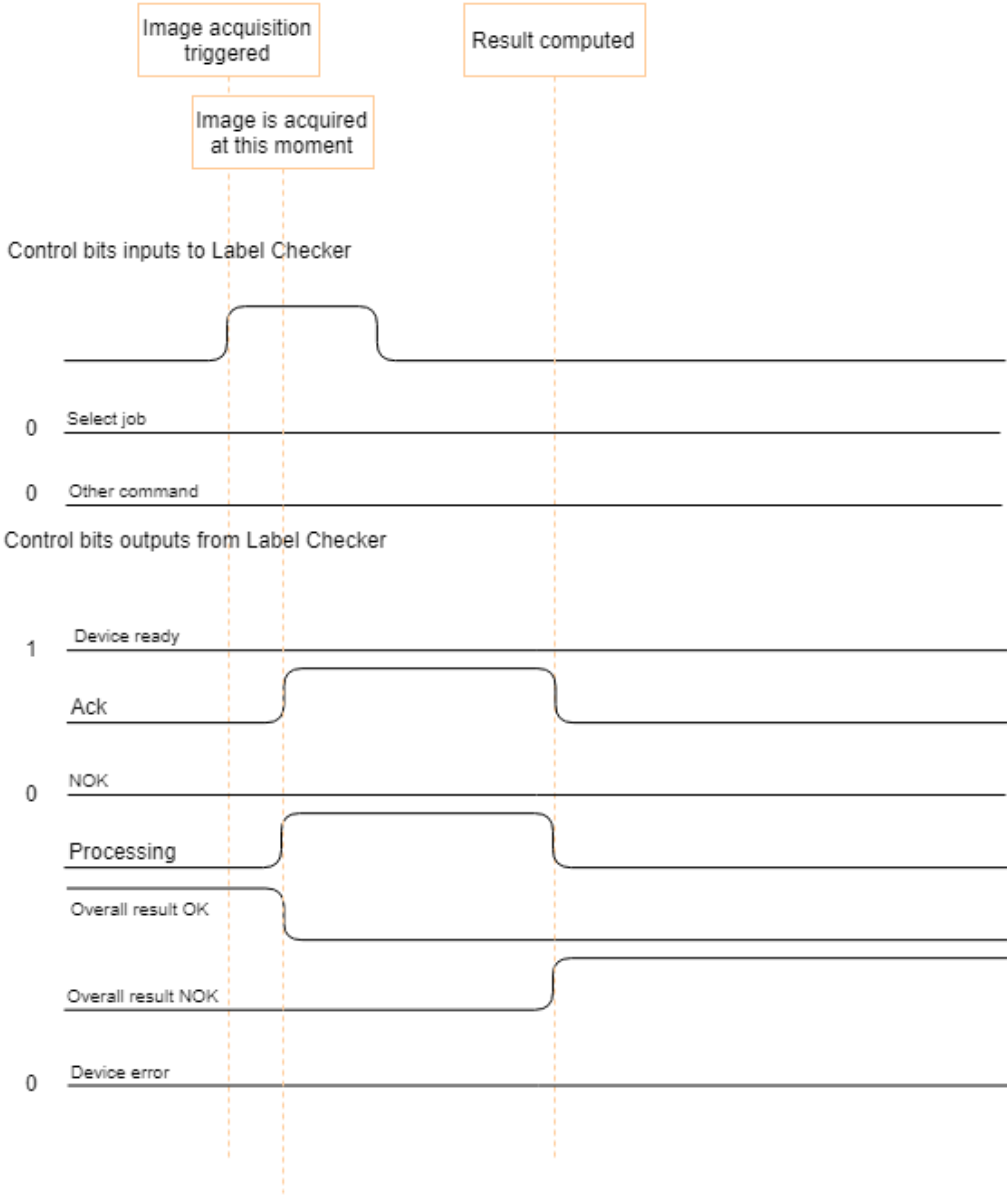

Figure 108 Trigger result not OK

Select job (Job exists) -> ACK

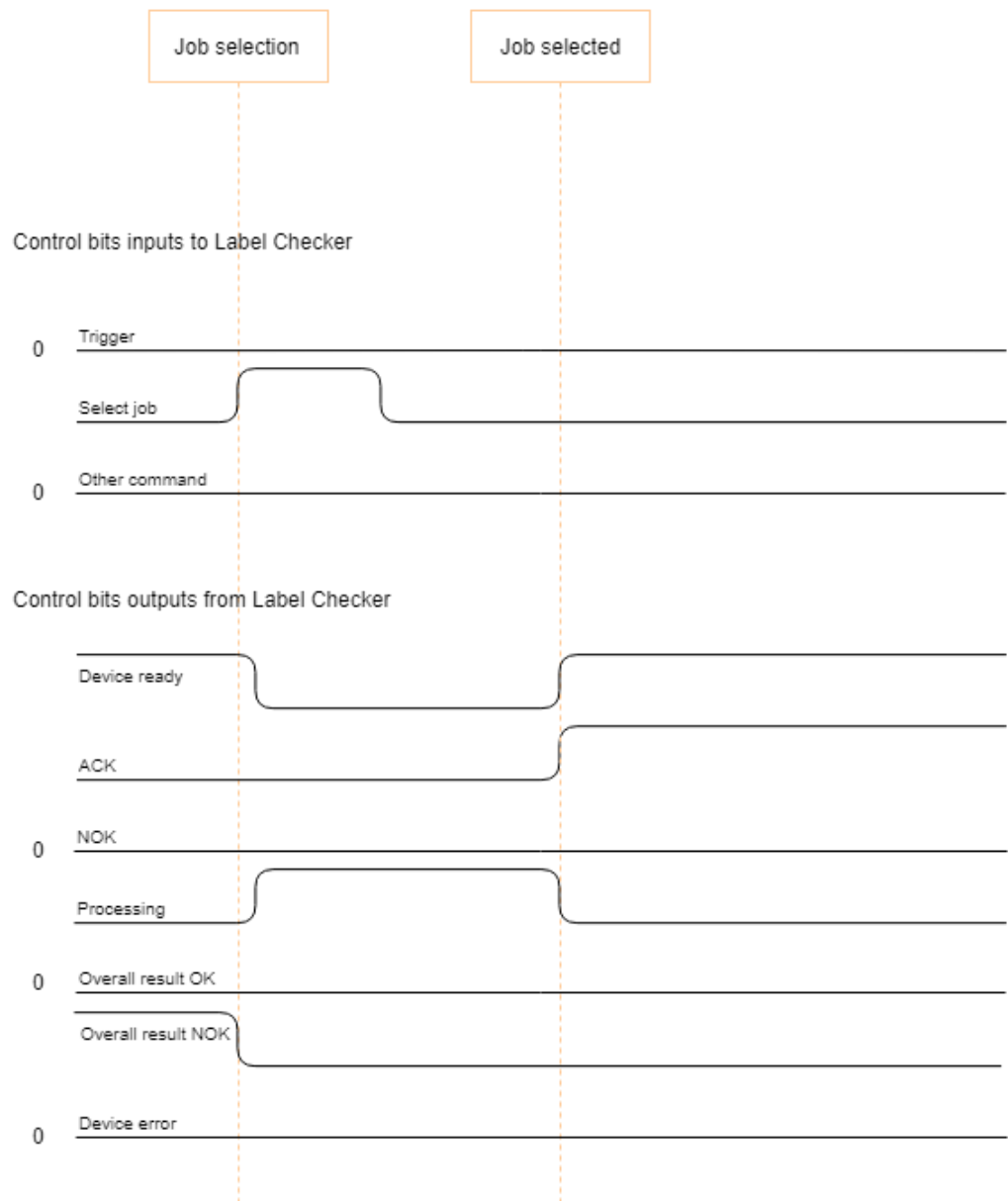

Figure 109 Select job exist

Select job (Job does not exist) -> NOK

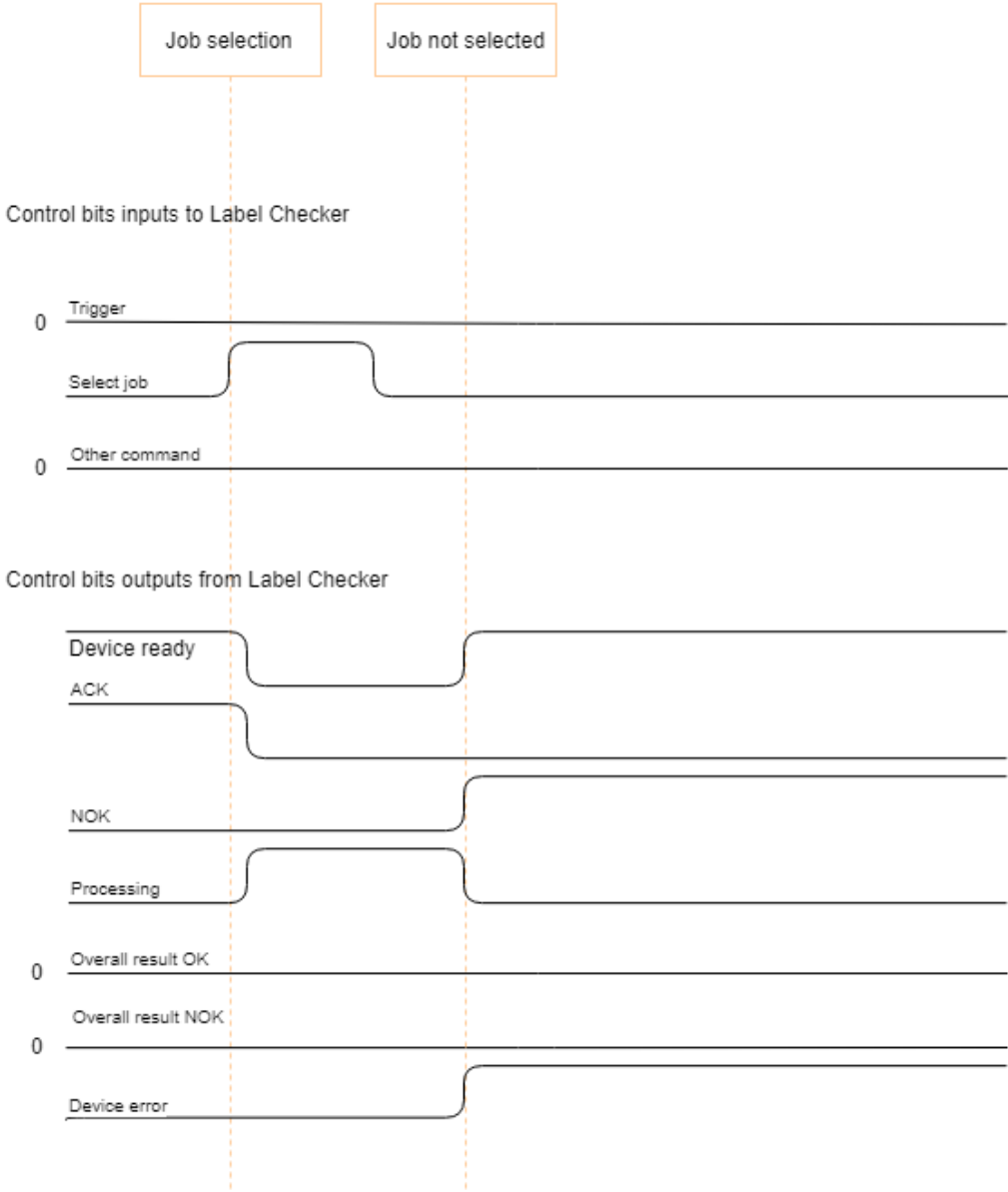

Figure 110 Select job does not exist

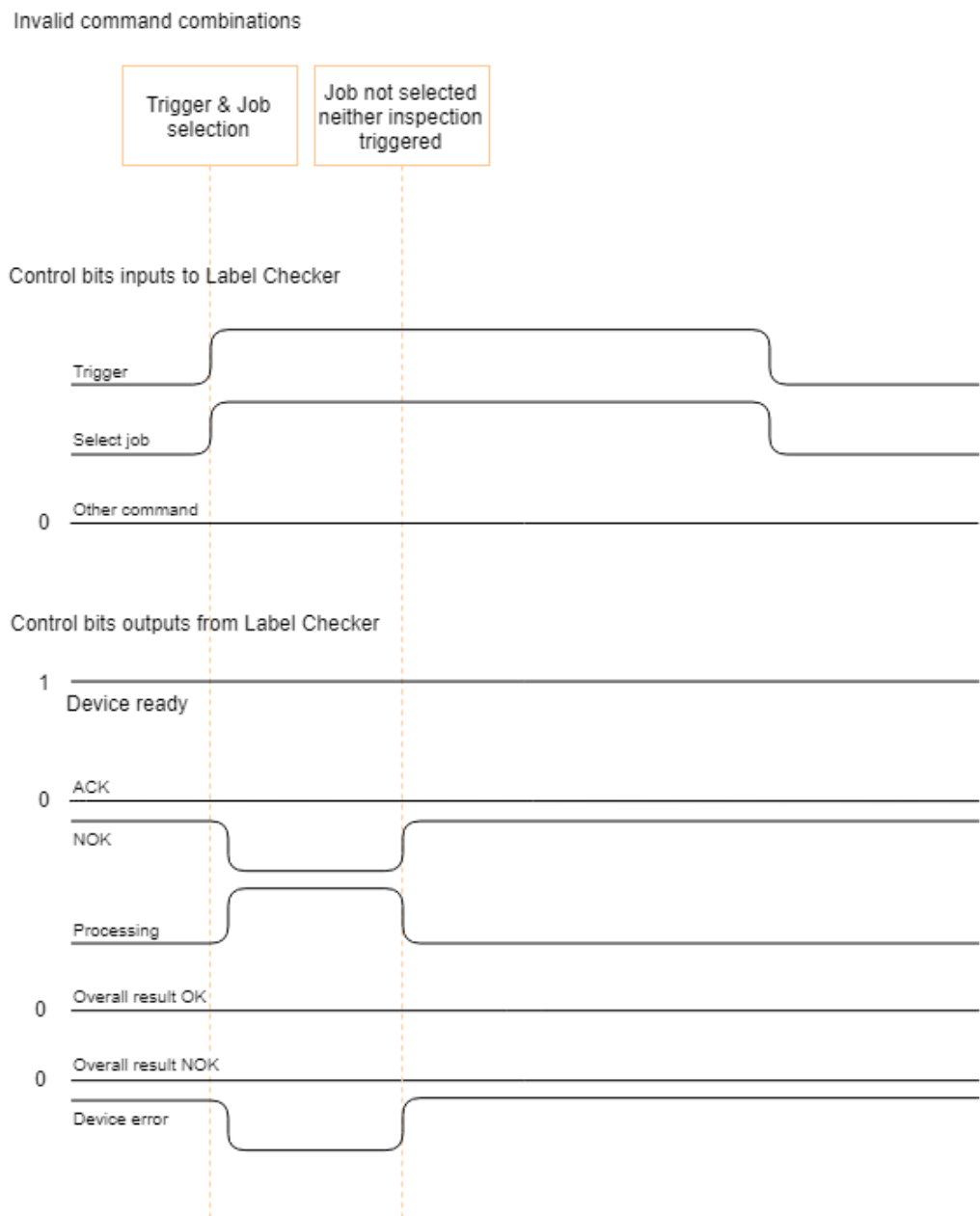

Figure 111 Invalid command combinations

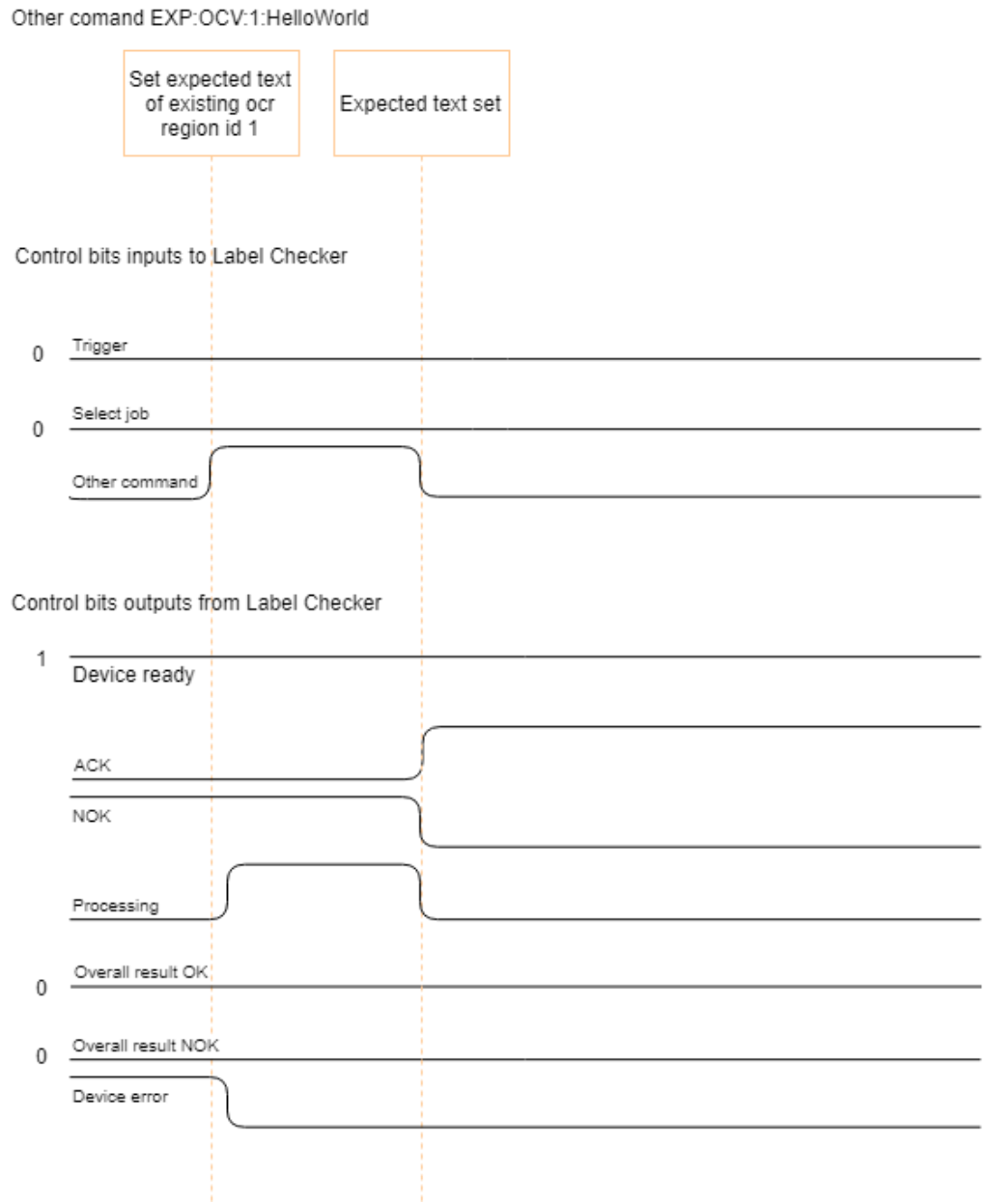

Figure 112 Other comand - existing OCR

## 4 GETTING STARTED

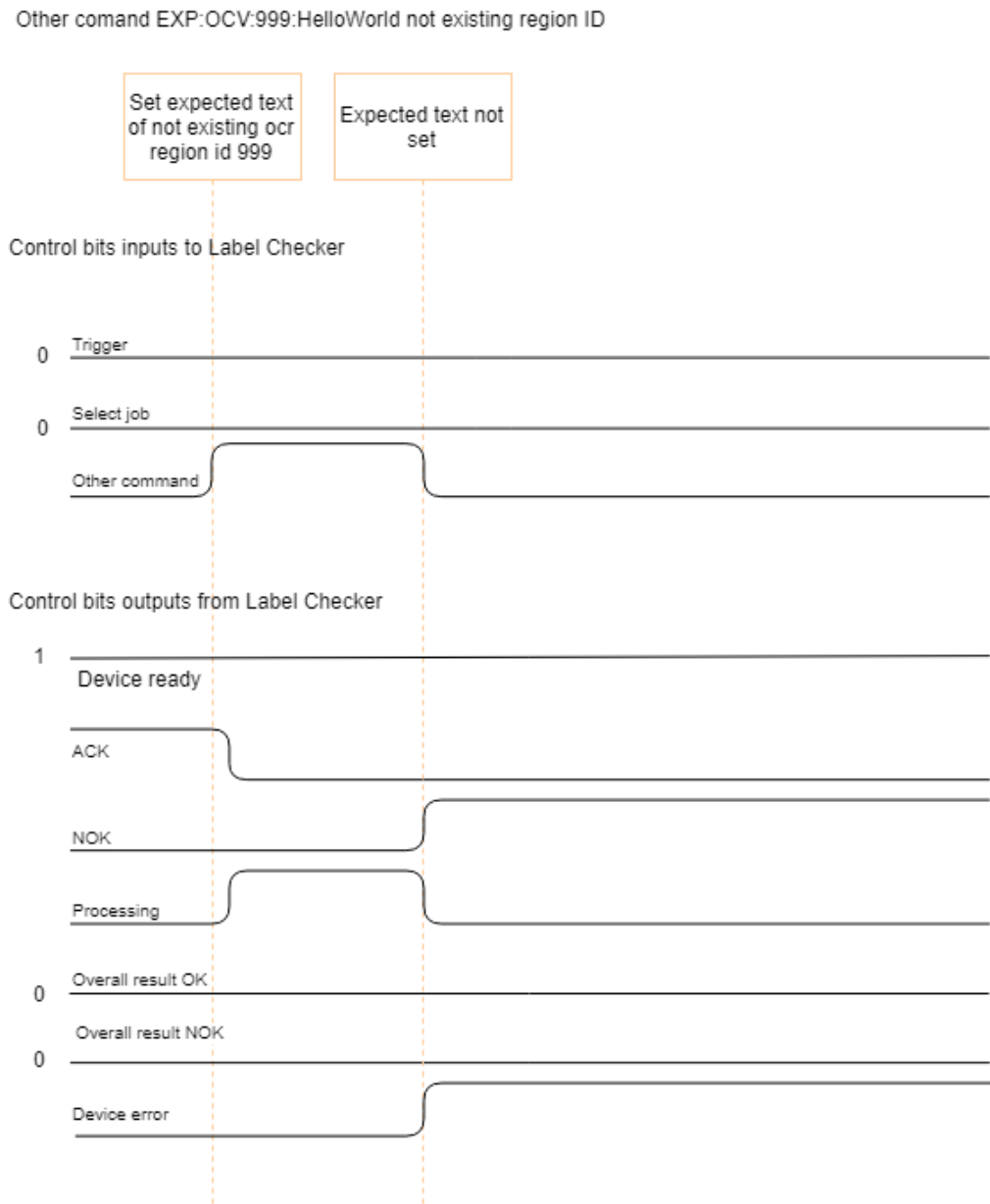

Figure 113 Other command - OCR not existing



Invalid command combinations

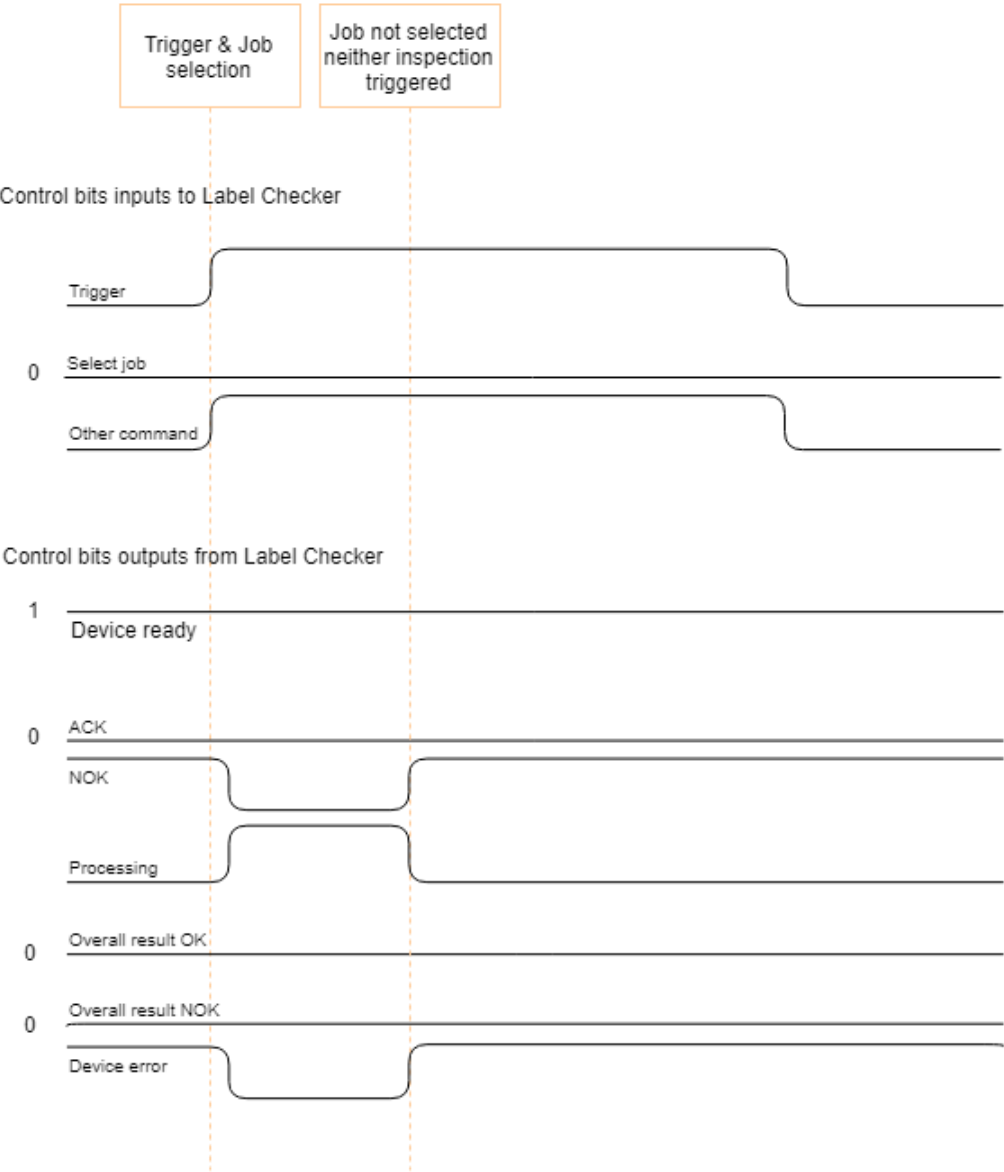

Figure 114 Invalid command combinations

## 4 GETTING STARTED

---

### 4.15.6 LBC621 supported communication interfaces

PROFINET	Not supported (support will be added in 2021)
Ethernet IP	Supported
TCP/IP	Supported
UDP	Supported
Serial	Not supported
DI/DO	Supported

### 4.15.7 LBC63x/64x/65x supported communication interfaces

PROFINET	Supported
Ethernet IP	Supported
TCP/IP	Supported
UDP	Supported
Serial	Supported
DI/DO	Supported

## 4.15.8 CDBF600 module setup



Please be informed that you must be a “Service” level user in order to access the CDF module settings.



Please be informed that any changes applied will only be saved, if you have re-activated the  button.

All inspection regions will be displayed after image processing is finished with a short delay.

**Proceed as follows:**

1. Set the CDF module to Gateway mode.
2. Adjust the mode switch to Position 2.



PROFINET version to position 2 or 3 depending on PROFINET address.

3. Configure the CDF module to “handshake” mode.
4. Using SOPAS ET software set the “Communication mode” of the PROFINET version to “Mode CDF600”.



Please be informed that the PROFINET versions of CDF module always communicate via “handshake” mode.

The Label Checker will not allow the use of external input “EXT IN1” in the CDF module.

**When using PLC, the following files are necessary:**

GSDML file                      Gateway operating mode CDF600-2 PROFINET

**The following PLC function blocks are necessary:**

S7 function bloc S7-1200/1500TIA                      Handheld, non-SOPAS devices, PROFINET

S7 function bloc S7-300/ 400 step 7 V5.5                      Handheld, non-SOPAS devices, PROFINET

## 4 GETTING STARTED

---



---

You may download these files on [www.sick.com](http://www.sick.com) CDF module under download section.

---



---

All communication commands functions in the same manner as the other communication modes.

---

4.16 Output format

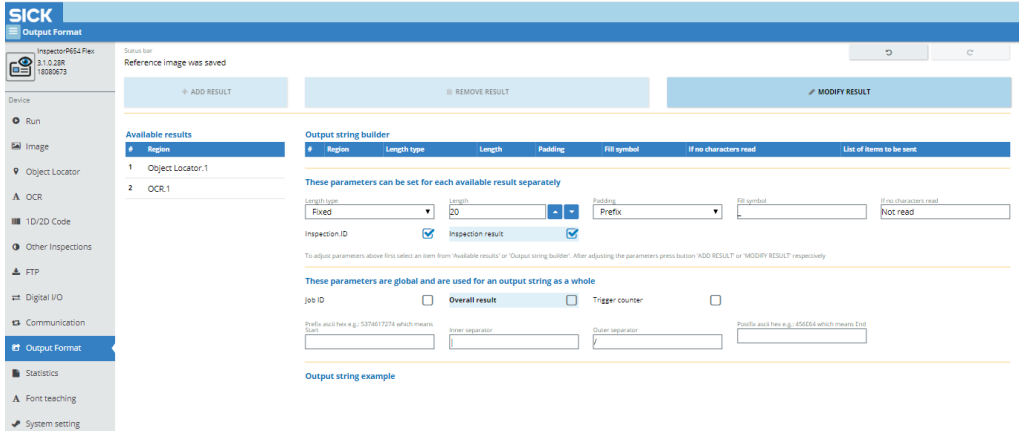
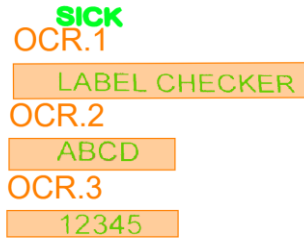

Figure 115 Output format

Table 6 Output format strings

<p><b>Output Format</b></p>	<p>Builds an output string, which is sent to all enabled communication interfaces (TCP, PROFINET, Ethernet IP, UDP, Serial HOST, Serial AUX) after the acquired image is processed. It's a result of one image acquirement.</p> <p>It can be built from the results of each inspections/regions defined by a user on „object locator“, „OCR/OCV“, „1D/2D Code“, and other inspections.</p> <p>Each inspection type has a different set of commands:</p> <p><b>Object locator</b> Inspection ID, result, position x [px], position y [px], and angle °.</p> <p><b>OCR/ OCV</b> Inspection ID, result, Position x [px], Position y [px], angle °, read text, minimum confidence, and expected text.</p> <p><b>1D code</b> Inspection ID, result, position x [px], position y [px], angle °, read text, and print quality.</p> <p><b>2D code</b> Inspection ID, result, position x [px], position y [px], angle °, read text, print quality, and expected text.</p> <p><b>Pixel counter</b> Inspection ID, and result.</p> <p><b>Pattern verification</b> Inspection ID, result, and match %.</p> <p><b>2D measurement</b> Inspection ID, and result.</p> <p>Operating entities can select from these items according to their preference.</p>
-----------------------------	---

**Example of output string creation with all read data for Object locator + 3x OCR regions:**



1. Add the OCR result to the string builder.
2. Select the OCR.1 result and CLICK the ADD result button. You need to repeat this process for all three results.



**Available results**

#	Region
1	Object Locator.1
2	OCR.1
3	OCR.2
4	OCR.3

3. You will find all results in the “Output string builder”.

**Output string builder**

#	Region	Length type	Length	Padding	Fill symbol	If no characters read	List of items to be sent
1	OCR.1	FIXED	20	PREFIX	_	Not read	
2	OCR.2	FIXED	20	PREFIX	_	Not read	
3	OCR.3	FIXED	20	PREFIX	_	Not read	

4. Enable the “Result” feature and select the data that you would like to be present in the Output string.

Length type: Fixed | Length: 20 | Padding: Prefix | Fill symbol: \_ | If no characters read: Not read  
 Inspection.ID:  Result

Position x [px] |  Read text  
 Position y [px] |  Min. confidence  
 Angle [°] |  Expected text

5. If you would like to add the “Read text”, tick the read text box, then select apply button to confirm.

Position x [px] |  Read text   
 Position y [px] |  Min. confidence   
 Angle [°] |  Expected text

6. The Output string result will be:

Output string example  
 \_\_\_\_\_LABELCHECKER/\_\_\_\_\_ABCD/\_\_\_\_\_12345



The default setting is composed of a fixed 20 character long string, filled with “ \_ ” symbol and “/” separator.

**With variable width:**

Output string builder

#	Region	Length type	Length	Padding	Fill symbol	If no characters read	List of items to be sent
1	OCR.1	VARIABLE	20	PREFIX	_	Not read	Read text
2	OCR.2	VARIABLE	20	PREFIX	_	Not read	Read text
3	OCR.3	VARIABLE	20	PREFIX	_	Not read	Read text

**OUTPUT STRING FINAL RESULT:**

Output string example

**LABELCHECKER/ABCD/12345**

- 7. If you would like to add the prefix START and postfix STOP, you can do it by entering the hexadecimal ASCII character values into the prefix and postfix fields.

The ASCII values for:

**START**

S = 53, T = 54, A = 41, R = 52, T = 54

**STOP**

S = 53, T = 54, O = 4F, P + 50

Prefix ascii hex e.g.: 5374617274 which means Start	5354415254	Inner separator		Outer separator	/	Postfix ascii hex e.g.: 456E64 which means End	53544F50
---	------------	-----------------	--	-----------------	---	--	----------

**Output string final result:**

Output string example

**STARTLABELCHECKER/ABCD/12345STOP**

**Items**

Read Text	Characters read by camera -> OCR/OCV or 1D/2D code
Region type	Inspection type, so it can be one of the following: „Object locator“, „OCR/OCV“, „1D/2D Code“
Region Id	Identification number of inspection/region. Identified as the last digit from the inspection name and dot. E.g. Object Locator.5 -> Region Id = 5

## 4 GETTING STARTED

---

Result	The result of inspection. Ok -> 1, otherwise 0.
Expected text	<p>Read characters expected by the user.</p> <p>If option Character verification was enabled, then the user must set the expected text.</p> <p>Setting „Expected text“ from OCR/OCV or „1D Code Expected Text“ or „2D code Expected Text“ from 1D/2D is a content of this item.</p>
No Read String	If no string is read, then the item „Read Text“ will be replaced by this parameter.



Table 7 Item parameters strings

<b>Items parameters</b>	Setting the following user parameters can modify the final format output string.
Position x [px] Position y [px]	All position numbers are represented as string without decimal point. You need to convert string value to number, then divide it by 100. Example: "2190" = 21.9 "100" = 1.0
Length Type	Fixed – The item always have the same length. <ul style="list-style-type: none"> <li>• If the item is shorter, then it will be completed/filled by a „Fill Symbol“.</li> <li>• If the „Padding“ parameter is PREFIX, then the fill symbols are placed in front of the item, otherwise from behind. The final length is always the same as the parameter „Length“.</li> </ul> Variable – The length of the item is kept. The length can vary for each iteration and each item.
Length	Length of each item, if the “Length Type” is fixed.
Fill symbol	If the “Length Type” is Fixed, then the “Length” symbol is used to complete for each desired item.
Padding	PREFIX - fill symbols are placed in front of the item. POSTFIX - fill symbols are placed behind the item.  <b>Example 1</b> Read Text = ABCD, „Length Type“= FIXED, „Length“= 12 “Padding” = PREFIX, “Fill Symbol” = ‘*’. Then the output string appears as follows:  *****ABCD  <b>Example 2</b> Read Text = ABCD, „Length Type“= FIXED, „Length“= 10 “Padding” = POSTFIX, “Fill Symbol” = ‘-’. Then the output string appears as follows:

	<p>ABCD—</p> <p><b>Example 3</b></p> <p>Read Text = ABCDEFGHIJKLMNOPQRSTUVWXYZ, „Length Type“ = FIXED, „Length“ = 10 “Padding” = POSTFIX, “Fill Symbol” = ‘-‘.</p> <p>Then the output string appears as follows:</p> <p>ABCDEFGHIJ</p> <p><b>Example 4</b></p> <p>Read Text = ABCD, „Length Type“ = VARIOUS</p> <p>Then the output string appears as follows:</p> <p>ABCD</p>
Separators	<p>Inner Separator - Separates an output of each item.</p> <p>Possible items:</p> <p><b>Object locator</b> Inspection ID, result, position x [px], position y [px], and angle °.</p> <p><b>OCR/ OCV</b> Inspection ID, result, Position x [px], Position y [px], angle °, read text, minimum confidence, and expected text.</p> <p><b>1D code</b> Inspection ID, result, position x [px], position y [px], angle °, read text, and print quality.</p> <p><b>2D code</b> Inspection ID, result, position x [px], position y [px], angle °, read text, print quality, and expected text.</p> <p><b>Pixel counter</b> Inspection ID, and result.</p> <p><b>Pattern verification</b> Inspection ID, result, and match %.</p> <p><b>2D measurement</b> Inspection ID, and result.</p> <p>Outer Separator - Separates an output of each result/inspection.</p> <p>Possible inspections:</p> <ul style="list-style-type: none"> <li>• Object locator</li> <li>• OCR/OCV</li> <li>• 1D code</li> <li>• 2D code</li> <li>• Measurement 2D</li> <li>• Pixel counter</li> <li>• Pattern verifier</li> </ul>

Table 8 Other strings

<b>Other</b>	
	<p>Region - Name and Id of inspection/region defined by the operating entity in the current job.</p> <p>Format: regionName.Id. (Cannot be set).</p> <p>List of Items to be sent - One inspection/region contained in output string (cannot be set).</p> <p># - table line number (Cannot be set).</p>
<b>Available Results</b>	<p>Inspection/Regions which are defined in the current job. Such as; object locator, OCR/OCV, 1D/2D Code,</p> <p>This list corresponds to the regions added in a current job for:</p> <ul style="list-style-type: none"> <li>• Object locator page</li> <li>• OCR/OCV page</li> <li>• 1D code page</li> <li>• 2D code page</li> <li>• Measurement 2D page</li> <li>• Pixel counter page</li> <li>• Pattern verifier page</li> </ul> <p># - Table line number (not important)</p> <p>Region – Name and Id of inspection/region defined by a user in a current job. Format: regionName.Id.</p>
<b>Control Buttons</b>	
Add Result	Add selected inspection/region to an output string.
Remove Result	Remove selected region from the output string.
Modify Result	<p>Change parameters of selected part of the output string having regard the following parameters: Read Text, Region type, Region Id, Result, Expected text, Length Type, Length, Fill Symbol, Padding, and No Read strings.</p> <p>Overall results parameter – complete results of all defined inspections.</p>

## 4 GETTING STARTED

---

Apply Button	Save all settings
<b>Output String Example</b>	<p>Displays real output string which is sent as a result via UDP, TCP, or serial communication.</p> <p>If any result of the current job is available (at least one image has already been acquired and processed), then it contains a real data (read text etc.); otherwise default values are used.</p>

Table 9 Trigger and JOB*i*

TRIG	Trigger image acquirement and further image processing. Finally, the result is sent via some communication interface, if enabled.
JOB <i>i</i>	Select job number <i>i</i> in the camera. e.g., Command "JOB25select" the job number 25.

## 4.17 Camera simulator

### 4.17.1 How to work with the camera simulator

The following procedures will show you the step-by-step instructions on how to work with the camera simulator. Camera simulator works either with real device or camera emulator found in AppStudio.

#### Please proceed as follows:

1. Login as Service, password: servicelevel. Then, the camera simulator tab will appear.

2. Go to the camera simulator tab, select the simulator and click apply. The camera simulator job subfolder will be created in the public folder.

### 3. Drag and drop files from the camera simulator job subfolder

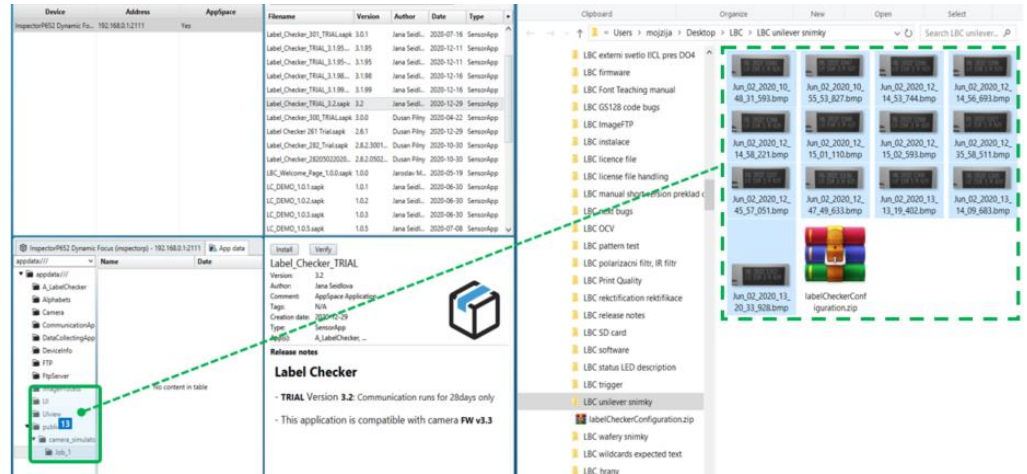

### 4. Then, the images will be filed in the camera simulator job subfolder.

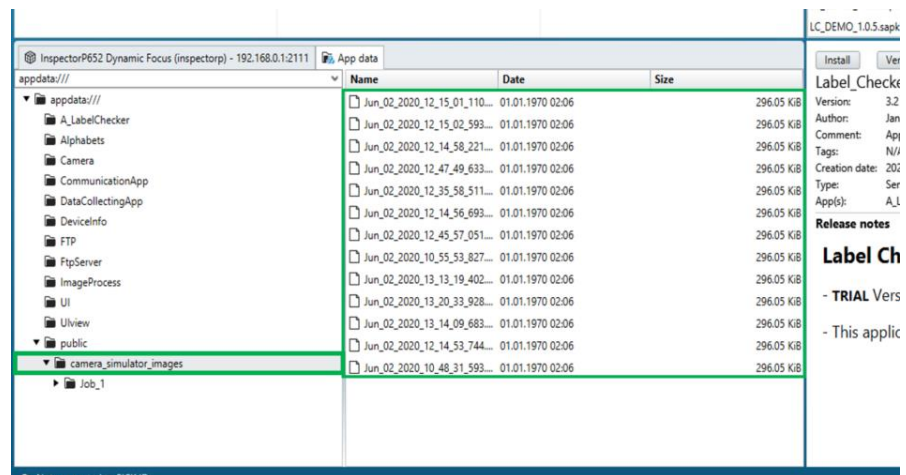

### 5. Now, select the apply button in the camera simulator tab once again.

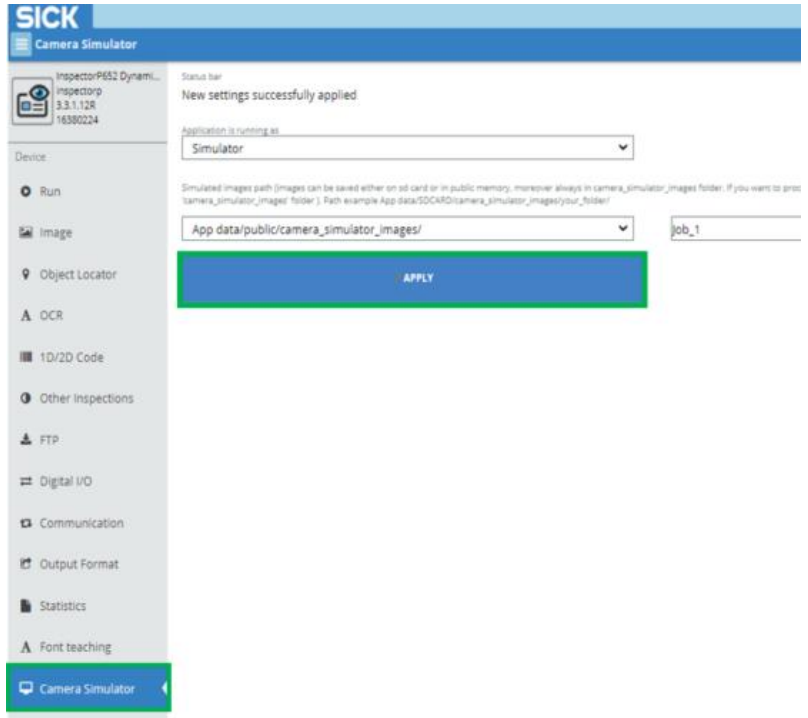

## 4 GETTING STARTED

6. Acquire a new image. The image from the camera simulator job folder will appear.

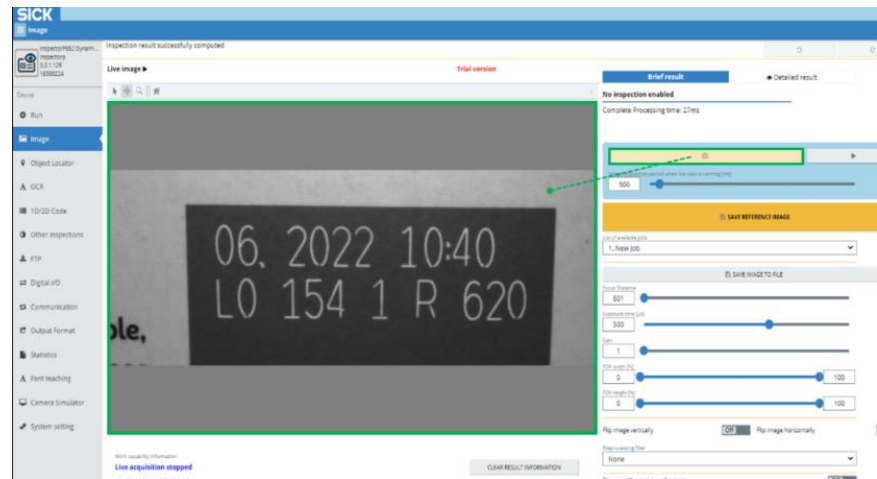



#### 4.17.2 How to use the camera emulator in the AppStudio and run the LBC app

The following procedures will show you the step-by-step instructions on how to use the camera emulator in AppStudio and run the LBC app on it.

##### Please proceed as follows:

1. Select the emulator tab and choose the type of camera that you would like to emulate, then select the emulator button to start.

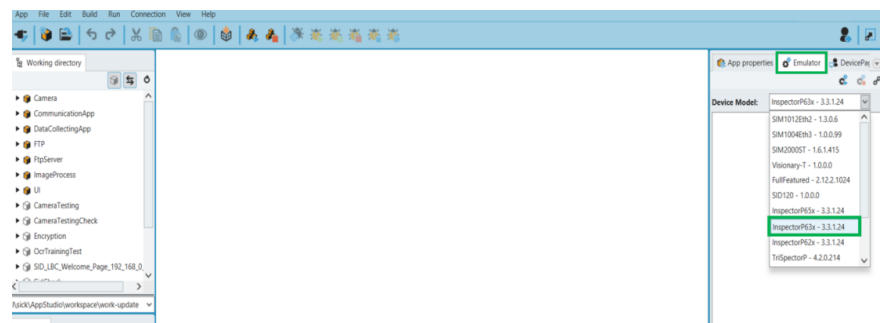

2. Start the camera emulator.

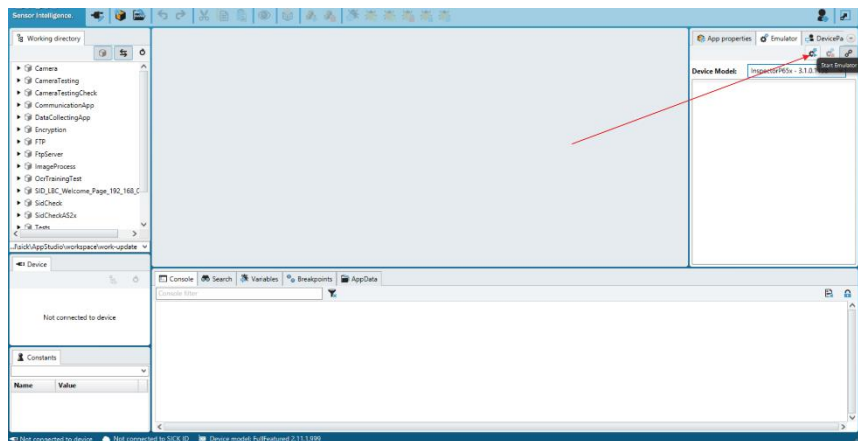

## 4 GETTING STARTED

3. The image sample shows that the camera emulator is running.

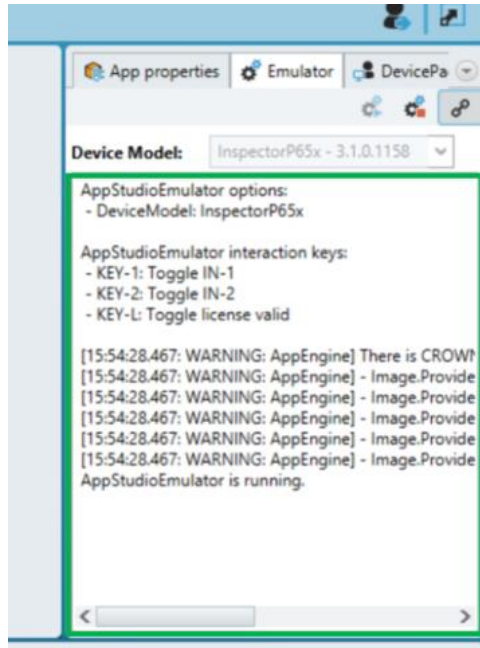

4. Start AppManager and connect to the camera emulator. Then select the OK button to install the LBC app.

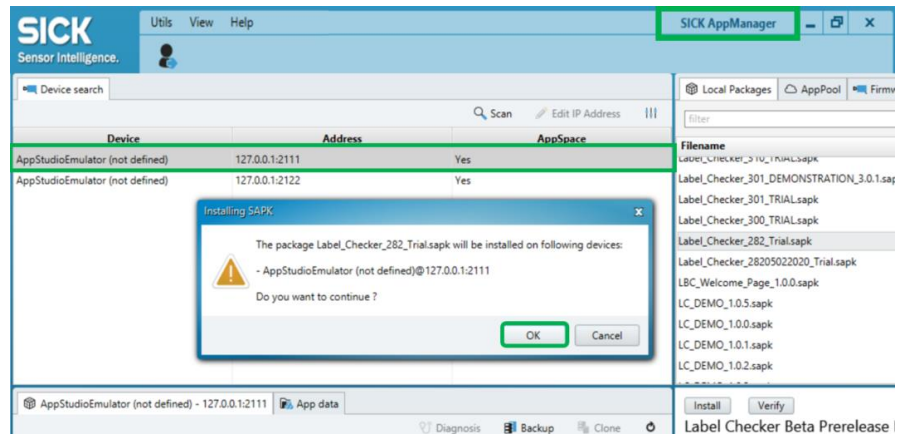

- Open a web browser, then insert the IP address of the camera emulator and its port (127.0.0.1:8080).

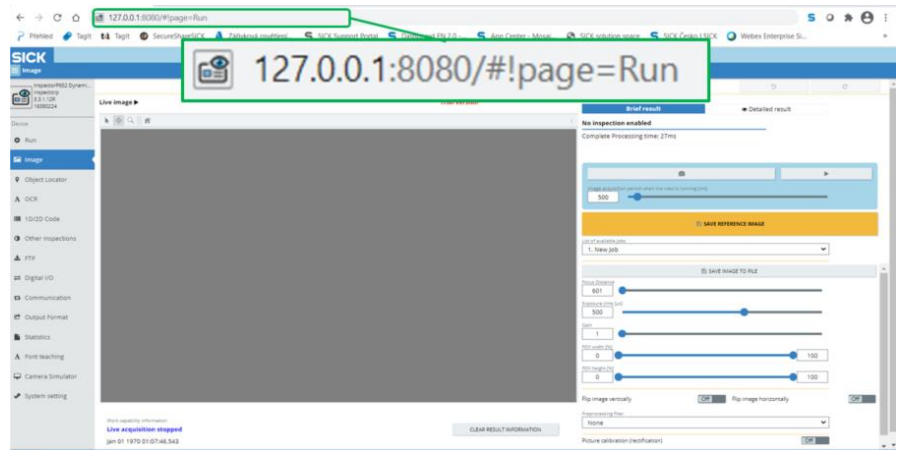

AppManager can be downloaded from:

<https://www.sick.com/cz/cs/sick-appspace/sick-appspace-software-tools/sick-appmanager/sick-appmanager/p/p532784>

AppStudio can be downloaded from:

<https://www.sick.com/cz/cs/sick-appstudio/p/p448644>



The camera simulator will not work if the camera is in use.

The path containing stored images from PC can be set up, when automatically emulated. The operating entity will acquire images from the camera's memory. Images will be provided instead of the camera inspection.



Images MUST be placed in the subfolder of the "camera\_simulator\_images" folder.

The images cannot be placed right into the "camera\_simulator\_images" folder, nor the public folder.



Halcon 12.3 or higher version run time license is needed to run camera emulator in AppStudio, image processing will not run without the Halcon USB dongle.

## 4 GETTING STARTED

---

### 4.18 Statistics

The Label Checker features a counter device which stores OK, NOK, and passing rate of created program inspections. The network time protocol (NTP) does not have to be set up in the system settings for the computer to synchronize with the time server. When a particular event occurs (such as; OK, NOK or passing rate) at any number of times, it will be reflected to the Label Checker's total counters. Please refer to subsection [4.19 System settings](#) in order to synchronize with the network time protocol (NTP).



Please be informed that it is not necessary to set up the NTP, but you will expect that the camera time and statistics will start from 00:00:00 Jan. 01.1970.

---

The operating entity can select to view the inspection statistics in monthly, weekly, or daily settings.

Select period to view statistics

Monthly	▼
Monthly	
Weekly	
Daily	



All statistic can be reset upon selection of the "Reset all statistics" button.

---

## 4.19 System settings

### 4.19.1 Camera

#### Camera buffer size

Camera buffer size [Image(s)]



Figure 116 Camera buffer size

The camera saves the images and image processing (inspections), which can store only 32 images to its buffer.

#### Camera process each n-th I/O trigger

Each n-th trigger ignites an image processing. Previous n-1 images are skipped.

Camera process each n-th I/O trigger



Figure 117 Camera process

### 4.19.2 Inspections

#### Set all inspection as ok

First type of the camera bypass, applies for the digital outputs as well as for the communication. Bypass is not shown in output editor example string. The statistics is also not influenced by this option.

#### Auto job switching

##### Inspections

Auto job switching



Figure 118 Auto job switching

When this feature is enabled and once the inspection is triggered, the LBC starts to execute the currently selected job, e.g. JOB3, then it tries to execute all the jobs below. Each job can be executed only once during one session.

### Count of failed inspections in a row

How many inspections in row can fail

Figure 119 Count of failed inspection

Second type of the camera bypass, applies for the digital outputs, as well as for the communication. Bypass is not shown in output editor example string. The statistics is also not influenced by this option.

### 4.19.3 Visualization

**Visualization**

Enabled  On

- Visualize inspection areas (rectangular border)
- Visualize inspection labels (method name.id)
- Visualize object locator countours (edges)
- Visualize other inspections edges
- Visualize other inspections dots
- Visualize regions (red, green areas of OCR, pixel counter etc.)
- Visualize detailed information

Figure 120 Visualization

Visualization provides an accessible way to see and understand the data in the program/inspection.

## 4.19.4 Time settings

**Time setting**

Set time manually

On

Year	Month	Day	Hour	Minute
2019	July	5	7	30

SET TIME

Figure 121 Time setting

In order to set the time manually.

**Proceed as follows:**

1. Open the system settings tab
2. Enable the Set time manually button
3. Select the following settings:
  - ▶ Year
  - ▶ Month
  - ▶ Day
  - ▶ Hour
  - ▶ Minute
4. Then, select the SET TIME when done.

**NTP Network Time Protocol**

NTP server IP address

10.0.0.2

NTP server port

123

Figure 122 NTP - Network Time Protocol

A protocol used for statistics to synchronize computer clocks (time) across the networks. The time server must be configured on an external device.



After installation/upgrade or if any error occurs, the camera must be reset to factory default.

## 4 GETTING STARTED

---

### 4.19.5 Save images on SD card

#### Save images on SD card

Enabled

Off

You have the option to enable/disable the Label Checker system in storing the images to the micro SD card.



4.19.6 Synchronize camera time with PC



Please be informed that you must be a “Service” level user in order to access in synchronizing camera time with the PC.



Please be informed that any applied changes will only be saved, if you have re-activated the **APPLY** button.

All inspection regions will be displayed after image processing is finished with a short delay.

- ▶ Open the system settings tab.
- ▶ Disable set time manually option.
- ▶ Fill in the network time protocol (NTP) IP address.
- ▶ Including the NTP port.

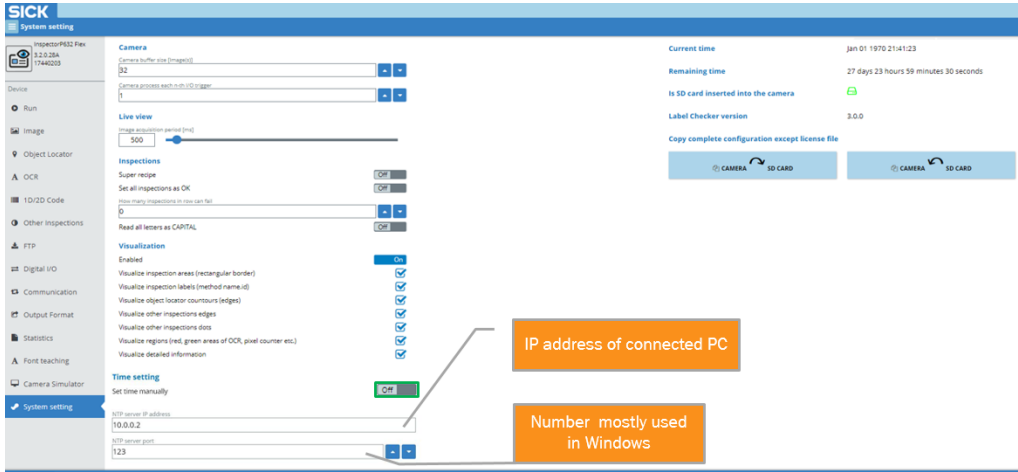

Figure 123 Network Time Protocol

## 4 GETTING STARTED

---

The following procedure belongs to PC connect to the camera:

1. Switch off all firewalls and antivirus apps (such as Avast) on connected PC or connected device, where we configure NTP server in the following steps.
2. Set the NTP Server on windows. Please visit this website:  
<https://www.interfacett.com/blogs/creating-standalone-ntp-server-windows/>
3. Finally resync time.
4. Open the command line as an administrator to resync time, and insert the command `w32tm /resync`. Then press enter.

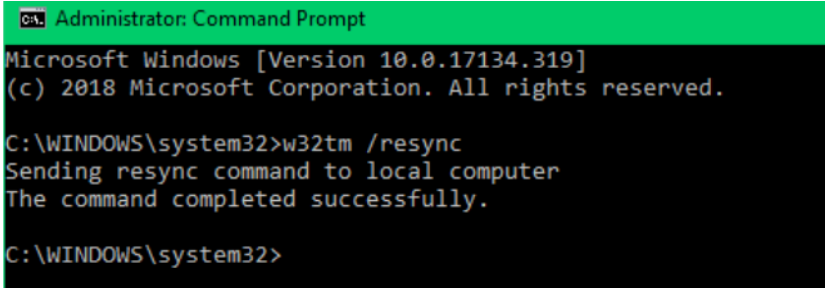

```
Administrator: Command Prompt
Microsoft Windows [Version 10.0.17134.319]
(c) 2018 Microsoft Corporation. All rights reserved.

C:\WINDOWS\system32>w32tm /resync
Sending resync command to local computer
The command completed successfully.

C:\WINDOWS\system32>
```

Figure 124 Command prompt

## 4.19.7 SD card backup cloning

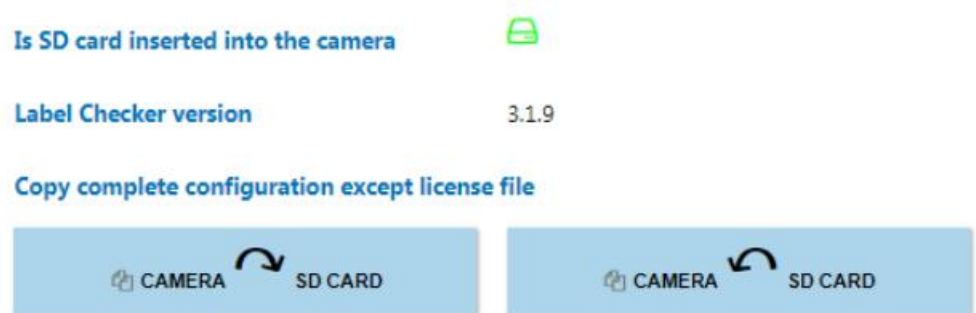

When a completely empty SD card is inserted into the configured LBC, after camera restarts **the configuration is automatically transferred into the SD card.**

When an SD card with previous backup of the same SW version is inserted (after camera restarts), **the configuration present on the SD card is loaded automatically.**

Then you can choose either to copy the configuration from the SD card and to the camera or vice versa, using SD card cloning buttons.

This is only visible in the System Settings tab, when the SD card is present in the camera. All files from the public folder are transferred (including all subfolders; e.g. images saved by the SD card save image function, camera simulator images etc.). When transferring configuration via SD card cloning buttons, destination is always erased and replaced with the source files.

When an SD card is inserted in the camera, at this point all of the jobs and configuration will be saved into SD card. (LBC version 3.2 or later)

This function is applicable for backup cloning between cameras. Firstly, transfer your configuration from the camera into an empty SD card, then insert the SD card into the new camera, afterwards transfer the configuration into it. You can also copy your configuration from SD card and into the camera, then insert another SD card and copy your configuration into it.

Please be informed that source and destination camera's FW and LBC versions must be the same. Please find subsection [5.3 Backup transfer to another camera for further information](#).

### 5 LBC Software

#### 5.1 Software installation



Please be informed that the ordered Label Checker 6xx camera is already preinstalled with the Label Checker software. **These steps should only be used if you want to install the software into an older camera or empty InspectorP camera.**

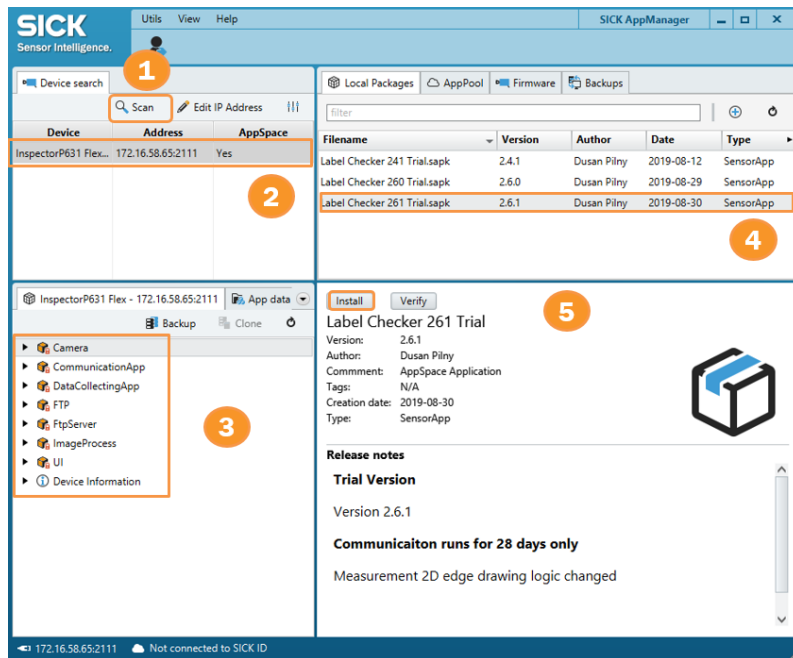

Figure 125 SICK AppManager

**Connect the camera and start the SICK AppManager.**

AppManager can be downloaded from:



<https://www.sick.com/cz/cs/sick-appspace/sick-appspace-software-tools/sick-appmanager/sick-appmanager/p/p532784>

1. Scan for camera
2. Select your camera.
3. Delete all applications in the camera<sup>1</sup>.
4. Select sapk. File.
5. Click install.

<sup>1</sup> **DO NOT** open/delete the content in the **App data** folder/tab.

## 5.2 Software update procedure and handling license file



---

Before updating your LBC software, it is highly recommended to back up your license file and configuration first, please see the [subsections 5.1, 5.2, and 5.3](#). **Trial version can be used for upgrading**, when the license file is detected, it will automatically switch to full mode. License is being detected after camera restarts.

---



---

Make sure that the latest InspectorP firmware is installed in the camera.

LBC software can be either installed when an SD card is present or not.

When an SD card is present in the camera, files on the SD card are not visible via AppManager. Please use the SD card backup cloning function first, and copy the files from SD card to camera's memory. Afterwards, remove the SD card, restart the camera and access the files.

---



---

AppManager can be downloaded from:

<https://www.sick.com/cz/cs/sick-appspace/sick-appspace-software-tools/sick-appmanager/sick-appmanager/p/p532784>

AppStudio can be downloaded from:

<https://www.sick.com/cz/cs/sick-appstudio/p/p448644>

---



---

Latest Label Checker software version can be obtained here:

<https://apppool.cloud.sick.com/publications/9e83965a-b671-43d8-af2a-34437d38f868>

---

**Please proceed as follows:**



---

You can select license file backup via AppManager (recommended) or FTP connection.

---

**Backup of License file using AppManager (recommended)**

1. Open the SICK AppManager
2. Then, select the scan button, select the camera.

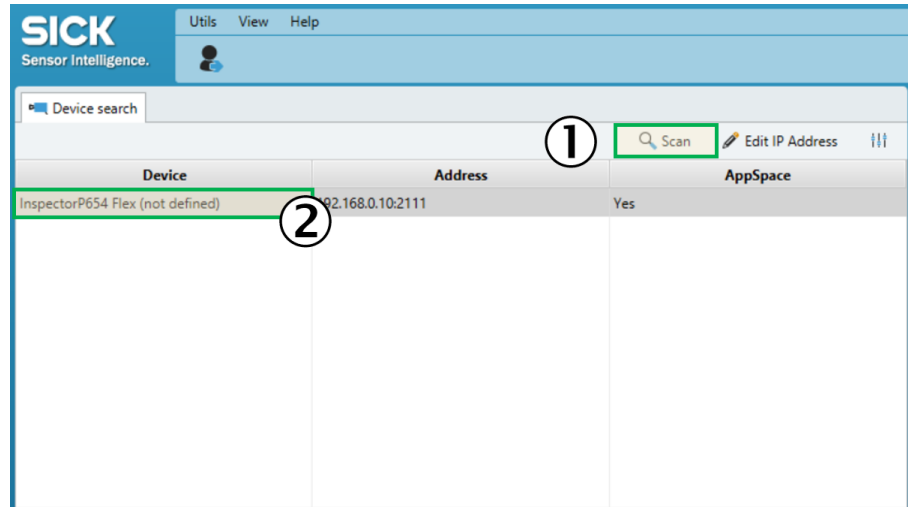

Figure 126 SICK App Manager – scan for the camera and select it

3. Open the AppData folder.
4. Afterwards, open the Public subfolder.

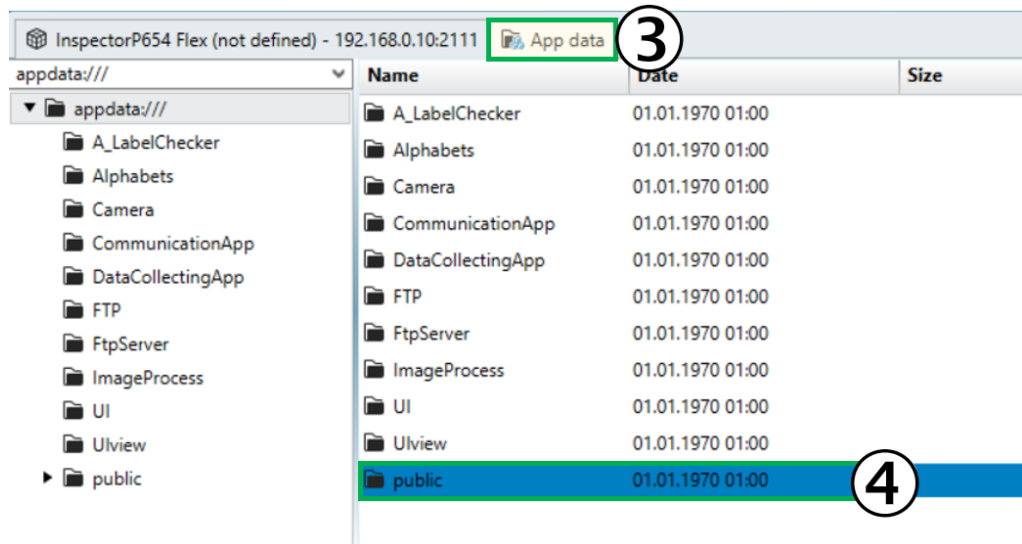

Figure 127 SICK App Manager – AppData folder access

5. Select the License.txt file.

- Next, right-click the mouse button and select “Copy to Disk”. Then, select the folder where the license file should be saved.

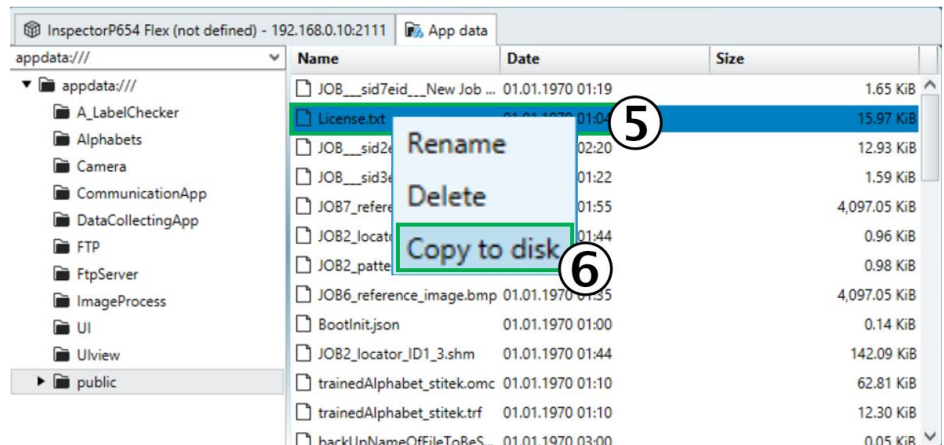

Figure 128 SICK App Manager – selecting the license file

- If it is necessary to copy the license file back to the camera (for example in case of accidental deletion of the license file), similar process should be used. License.txt file should be moved by “drag and drop” to the Public subfolder of the camera. File should be placed in the public subfolder, and not directly into it.

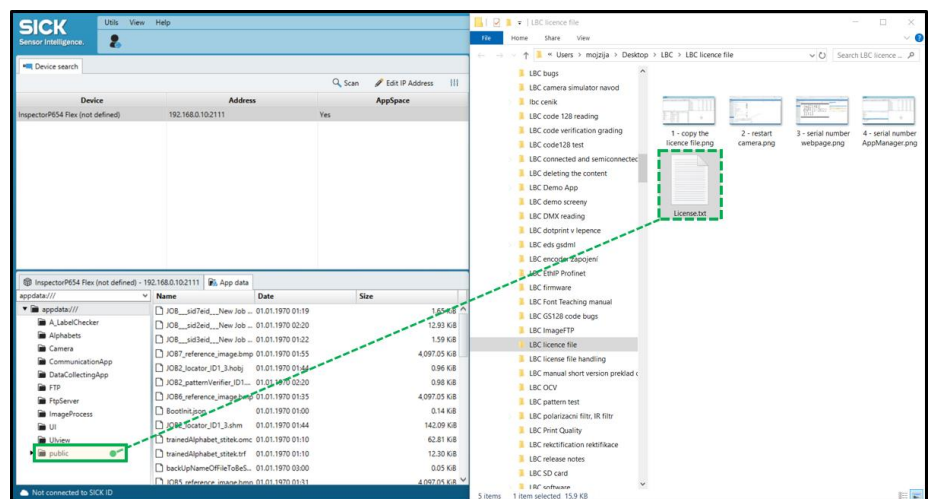

Figure 129 SICK App Manager – copying the license file back to the camera (if necessary)



There is an automatic license backup handling since v 2.85. After copying the license.txt file into the public folder and camera restart, then the license.txt file will be automatically copied into the UI folder. When the license.txt is accidentally deleted from the public folder, then the LBC software will stay in the "Full version" mode (takes the license from the UI).

**Backup of License file using FTP connection**

Not necessary if the backup was done via AppManager).

1. Connect to your camera using any FTP manager (FileZilla, Total Commander, and Free Commander).
  - ▶ Use IP address of the camera and port 65530
  - ▶ Username: Service
  - ▶ PSW: servicelevel

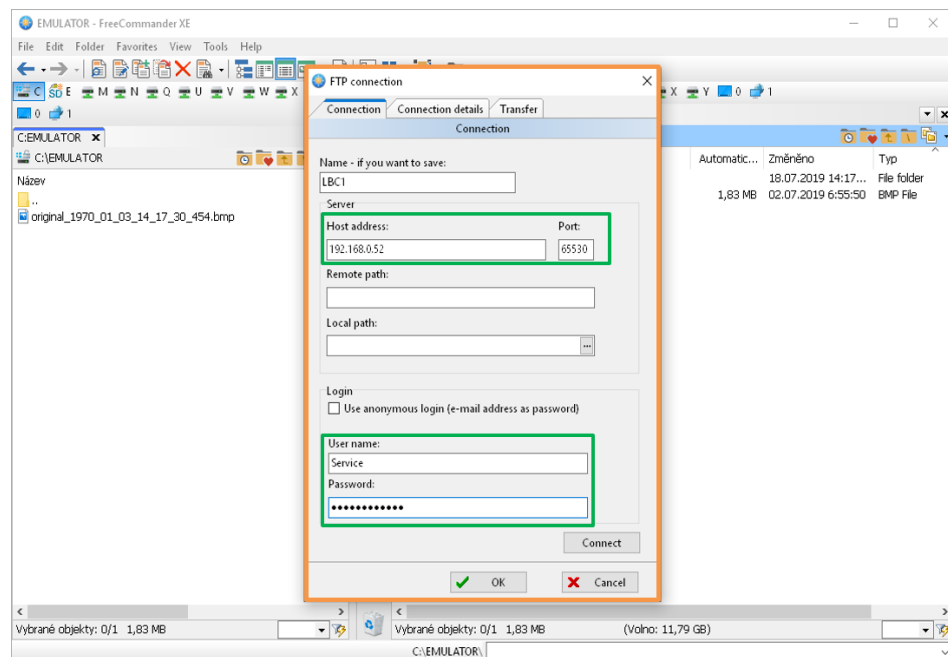

Figure 130 FTP Connection



2. Locate the License.txt file and copy it to your HDD or USB stick. The same procedure should be performed when copying the new license from HDD or USB stick (into the camera), in case of accidental deletion of the license file.

JOB12_locator_ID1_4.shm	390 kB	01.01.1970 0:00:00	SHM File
JOB12_locator_ID1_6.hobj	8 kB	01.01.2019 0:06:00	HOBJ File
JOB12_locator_ID1_6.shm	133 kB	01.01.2019 0:06:00	SHM File
JOB12_reference_image.bmp	1,83 MB	01.01.1970 0:00:00	BMP File
JOB13.json	2 kB	01.01.1970 0:00:00	JSON File
License.txt	16 kB	01.01.2019 0:01:00	Text Document
no-img.png	2 kB	01.01.2019 0:01:00	PNG File
no-ref.png	798 Byte(s)	01.01.2019 0:01:00	PNG File
trainedAlphabet_afb.omc	56 kB	01.01.1970 0:00:00	OMC File
trainedAlphabet_afb.trf	7 kB	01.01.1970 0:00:00	TRF File
trainingImage__afb__soc48eoc__2.png	199 Byte(s)	01.01.1970 0:00:00	PNG File
trainingImage__afb__soc48eoc__4.png	198 Byte(s)	01.01.1970 0:00:00	PNG File

Figure 131 License txt file

### Updating the LBC software using AppManager

1. Open the SICK AppManager and select the scan button, select the camera.

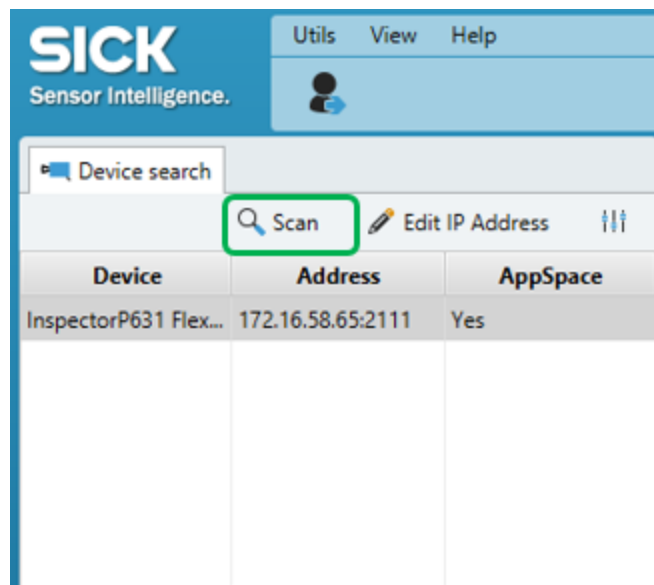

Figure 132 SICK App Manager – connecting to the camera

2. Afterwards delete all the contents from the camera.

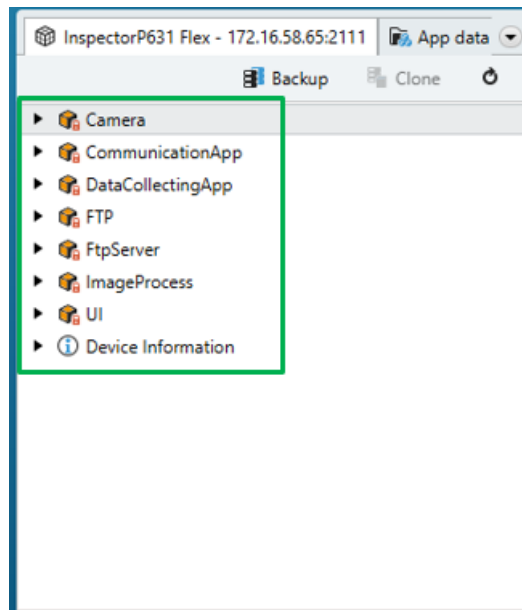

Figure 133 SICK App Manager – Camera folder content

3. Select the desired application package

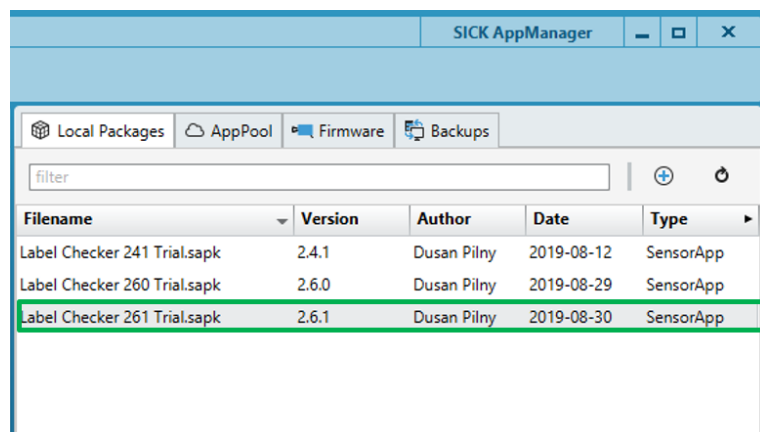

Figure 134 SICK App Manager – Available application package

4. Then, press the install button.

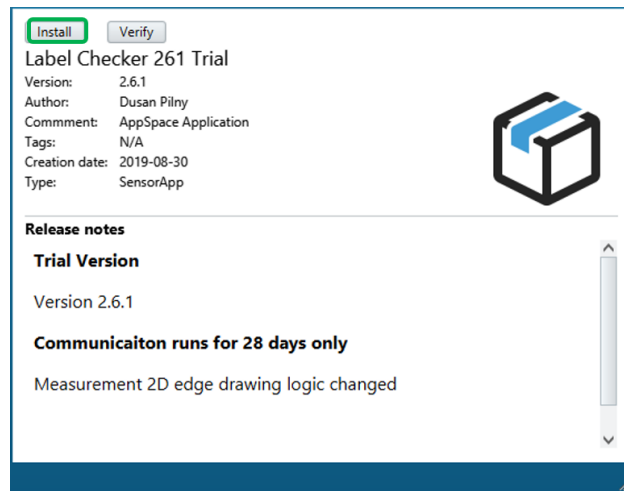

Figure 135 SICK App Manager – Installation



---

If the license file is not found, the LBC will switch to trial mode. If this is the case, please repeat the first step and then copy the license file back into the camera.

---

5. After successful installation, access the camera using the web browser.

- After login using Service/servicelevel, navigate to System settings and click the reset to factory default button.

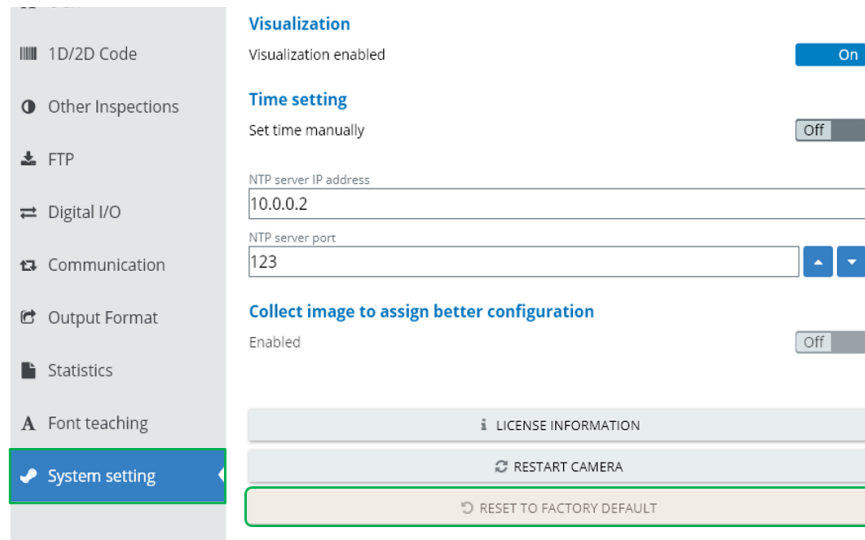

Figure 136 Resetting factory default



---

Updating to a new version/resetting the camera to factory default will not delete the license file.

---

### 5.3 Backup transfer to another camera and to HDD

---

You can easily use the SD card backup cloning function, to transfer your settings into another camera. In case you do not have an SD card or you would like to transfer your configuration on your laptop HDD, please find [subsection 4.19.7 of SD card backup cloning](#), for further information.

It's highly recommended to remove all the contents from the destination camera.

If the camera is new, then this procedure is not necessary.

---



---

If an SD card is present in the camera, the files in the SD card will not be visible via the AppManager. Please use the SD card backup cloning function first, and copy the files from SD card into the camera's memory. Afterwards, remove the SD card, restart the camera, and access the files.

---



---

Please make sure that both cameras have the same version of InspectorP firmware and LBC software (they must be of the same type, e.g. LBC621). Please, refer to subsection [5.4 Backup between versions](#), in case the versions/types are different.

The Job settings, including a few settings (i.e. digital I/O settings) will be transferred as well.

---

#### **Please proceed as follows:**



---

You can choose the way of backing up the settings files, via AppManager (recommended) or via FTP connection:

---

1. Follow the first step from the LBC update procedure (either for using AppManager or FTP connection), please find [subsection 5.2 Software update procedure and handling license file](#). Then, select all of the files (to be transferred) from the public folder to the camera.



---

The number of the files can vary. Copy these files to HDD or USB stick.

---

**Backup of settings using AppManager (recommended)**

1. Select all of the files to be transferred, except for the license.txt file from the public folder of the source camera. Then copy the transferred files to your USB or HDD.



If you would like to create a backup and use it for the same camera, then you should also include your license.txt files.

**Do not transfer** the license.txt file, if you would like to transfer the backup into another camera, since the target camera utilizes a **different** license.

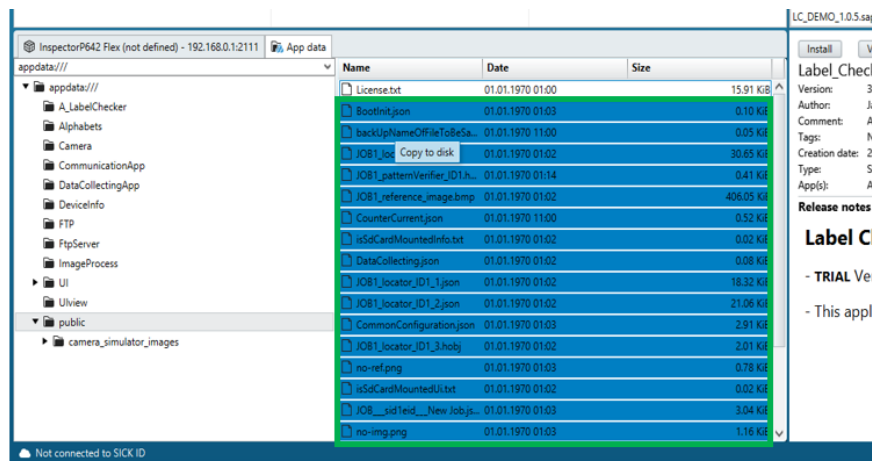

Figure 137 SICK App Manager – Backing up the files to HDD or USB stick



Backup of settings using FTP connection is not necessary if the backup was done via AppManager.

- Repeat the same step to access the target camera and upload all the files into its memory (AppManager is recommended). Backup files should be moved by “drag and drop” to the Public subfolder of the camera. Files must be dropped on the public subfolder, and not directly into it.

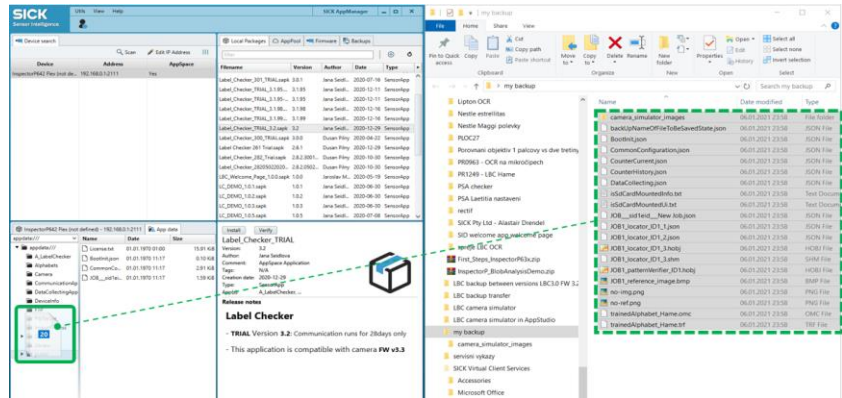

Figure 138 SICK App Manager – Copying the backup files back to the camera

- Access the camera using web browser and after log-in via Service/servicelevel, navigate to System setting tab and Restart the camera.

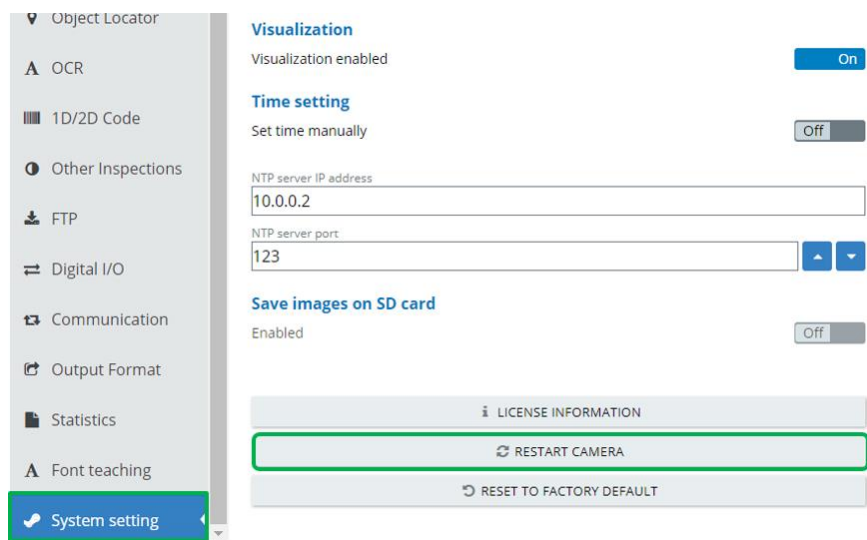

Figure 139 Setting tab & restarting camera



Updating to a new version/resetting the camera to factory default will delete all Jobs settings.

## 5.4 Backup transfer between different versions of Software and Firmware/different camera types



Please be informed that this procedure was tested from LBC642 v 3.0 to LBC652v3.2, FW v 3.3.1, and may not work for all combinations of camera types or SW and FR, particularly the previous versions, due to significant changes in the code. We recommend to initially backup your configuration on the HDD. Please find [subsections 5.2 of Software update procedure and handling license file](#) and [5.3 of Backup transfer to another camera](#).

**Please proceed as follows:**

1. Perform reset to factory defaults.

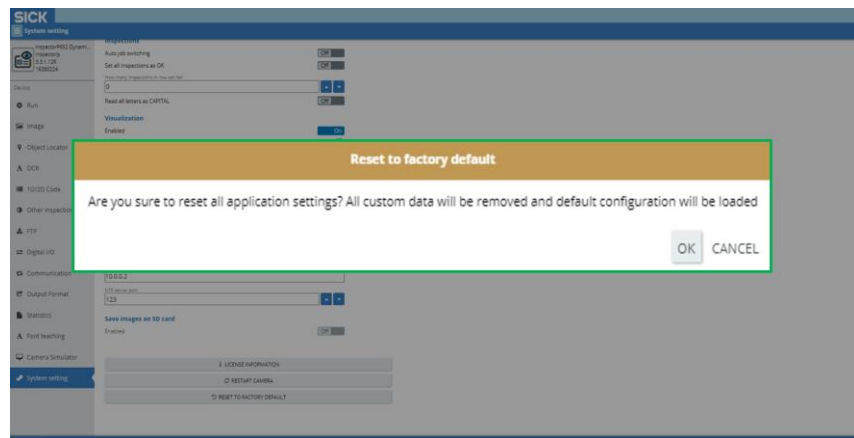

Figure 140 Reset application settings

2. Once the webpage is refreshed, the camera should be empty.

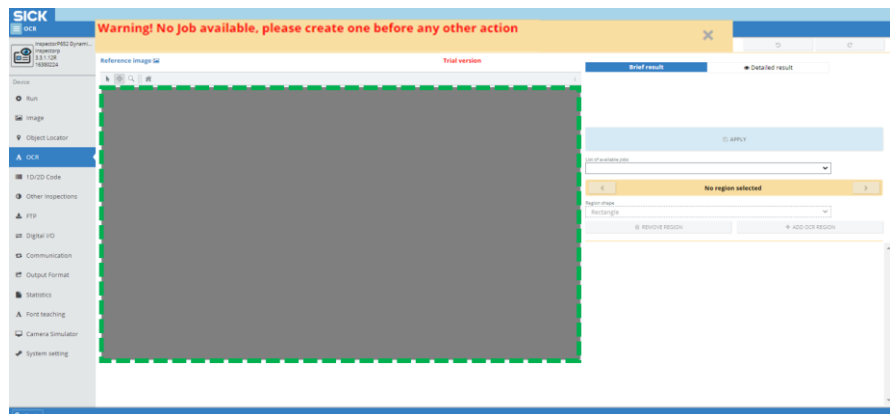

Figure 141 Empty camera



3. Delete these two files and leave only the bootinit.json file in the public folder, then select the OK button to verify deletion.

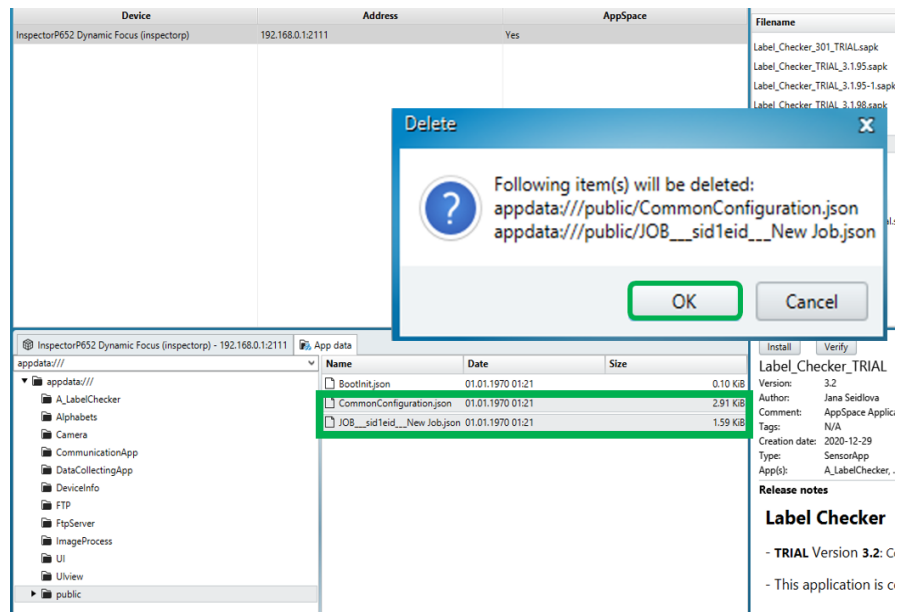

Figure 142 Deleted files

4. Copy your backup into the public folder without the bootinit.json file from the backup. Backup files must be moved by “drag & drop” to the public subfolder of the camera, and not directly into it.

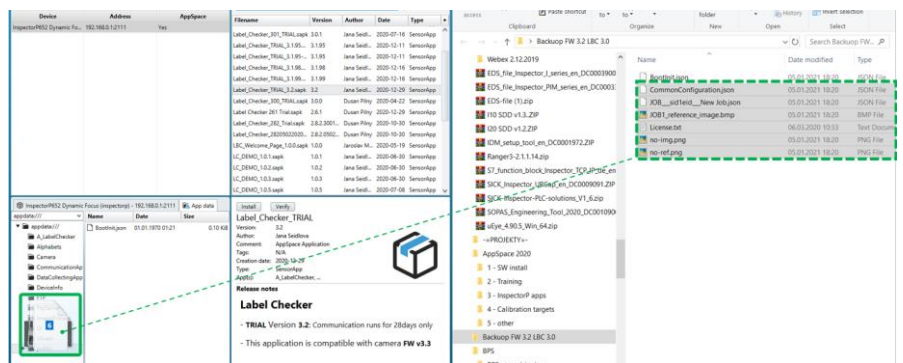

Figure 143 Backup into public folder



The bootinit.json file keeps the information of the FW and SW version, including the camera type (e.g. LBC621/LBC632), and is used when the configuration is created. When these information differs, the camera automatically performs “reset to factory defaults” and deletes all configuration. Thus, the bootinit.json file must be replaced with the latest file from the target camera.

5. The public folder should display, as shown on the following image sample.

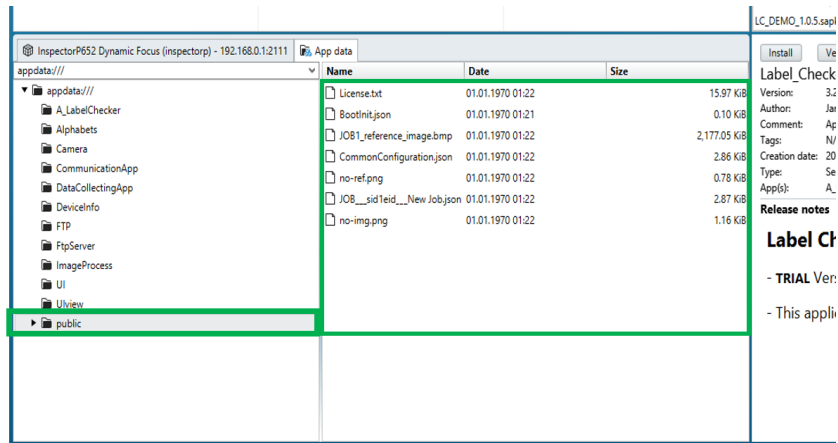

Figure 144 Public folder

6. Reset the camera

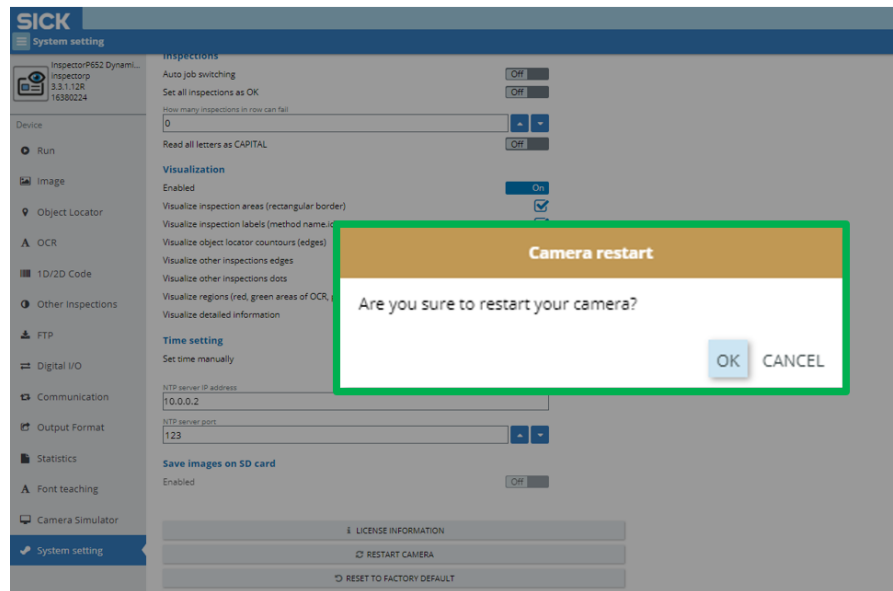

Figure 145 Camera reset

7. Finally, the backup will be present in your camera (camera in full mode).



When using an SD card, the procedure will be similar. You will need to place the bootinit.json file (from the target camera) into the source backup on the SD card, before inserting it into the target camera. Otherwise, your configuration will be automatically deleted.

Please be informed that the SD card is not accessible from the AppManager, thus the AppStudio or SD card reader in your PC must be utilized to replace the bootinit.json file.

## 6 Troubleshooting



SICK Service level has full access to the Label Checker system with all permissions including maintenance, commissioning, troubleshooting, and login privilege to restricted programs.

SICK service user level is restricted only for SICK employees.



The operator has the most limited role. They can only start the system with no authority to Edit or fix any programs.

### 6.1 Overview of possible faults & error

Situation	Error/ Fault
Mounting	<ul style="list-style-type: none"> <li>Device poorly aligned to the object (e.g. dazzle).</li> </ul>
Electrical installation	<ul style="list-style-type: none"> <li>Data interfaces of the device incorrectly wired.</li> </ul>
Programming	<ul style="list-style-type: none"> <li>See SICK AppSpace interface documentation (troubleshooting of individual objects and functions) found in InspectorP64x_65X.   <a href="https://visionsupport.sick.com/products/vision/2d-vision/programmable-cameras/inspectorp64x/">https://visionsupport.sick.com/products/vision/2d-vision/programmable-cameras/inspectorp64x/</a></li> </ul>
Operation	<ul style="list-style-type: none"> <li>Trigger control incorrect and/or not suitable for the object.</li> <li>Device faults (hardware/software).</li> </ul>

### 6.2 Detailed fault analysis

The statuses that can be read from the LEDs on the device housing includes.

- Operational readiness (Ready)
- Analysis result status (Pass or Fail)
- Hardware fault
- Firmware download status
- Connection status of the device

The LED display can indicate any errors or faults through detailed fault analysis.



For further information, please visit this link:

[https://cdn.sick.com/media/docs/9/79/779/Operating\\_instructions\\_InspectorP64x\\_65x\\_en\\_IM0068779.PDF](https://cdn.sick.com/media/docs/9/79/779/Operating_instructions_InspectorP64x_65x_en_IM0068779.PDF)

### 6.3 Resetting to factory mode

Resetting the Label Checker to its factory settings will result in deleting the following folders and files:

- Alphabets folder
- JobsEB folder
- Data folder
- BootInit.json file
- CommonParams.json file
- Default job JOB1.json file

The following files with default parameters will be created:

- public/Alphabets/\*.omc files
- public/bootInit.json file
- public/CommonParams.json file
- default job public/jobsEB/JOB1.json file

### 6.4 Beep description

Once the camera boots-up, it makes a notification sound, depending on which state it is.



**1x high frequency longer beep** – error in application boot-up

**1x low frequency short beep** – found valid configuration, camera restarted

**1x high frequency longer beep following by 1x low frequency short beep** – valid configuration was not found, camera restarts with factory defaults

### 6.5 Ready LED status description

#### LED status description

Display	LED	Color	Status
<b>Ready</b>		green	Sensor ready
		red	Hardware or sensor error
<b>Result</b>	Programmable	Red, green, blue, fuchsia, yellow, aqua, white	Function defined by user
<b>Light</b>	Programmable	Red, green, blue, fuchsia, yellow, aqua, white	Function defined by user
<b>Function</b>	Programmable	Red, green, blue, fuchsia, yellow, aqua, white	Function defined by user
<b>L/A GbE</b>		green	The device is connected to a network

Display	LED	Color	Status
<b>LED bar graph (0 - 4)</b>	Programmable	Red, green, blue, fuchsia, yellow, aqua, white	Function for each LED defined by user



= illuminated,



= flashing



Yellow color of the ready status LED indicates an installation of the SW. When installation ends, ready LED should turn green. If it doesn't, please perform a power cycle of the device.

## 6.6 Returning devices

- ▶ Do not dispatch devices to the SICK Service department without consultation.
- ▶ Please contact your nearest SICK company agent or representative.



Please include the following when making returns.

In order to process an efficient return request and allow us to quickly determine the cause.

- Details of the contact person
  - Description of the application
  - Description of the fault that occurred
- 

## 6.7 SICK Support

If the fault cannot be rectified, the device may be defective.

The operating entity cannot repair the device. Interference with or modification of the device will invalidate any warranty claims against SICK AG.

However, it is possible for the operating entity to acquire Rapid replacement of the device.



If a fault cannot be rectified, please get in contact with your nearest SICK Service department.

[www.sick.com](http://www.sick.com)

---



Before calling, make a note of all type label data such as type designation, serial number etc., ensuring faster telephone processing.

---

### 7 Appendices

#### 7.1 Optic filters

##### 7.1.1 Polarizing filter

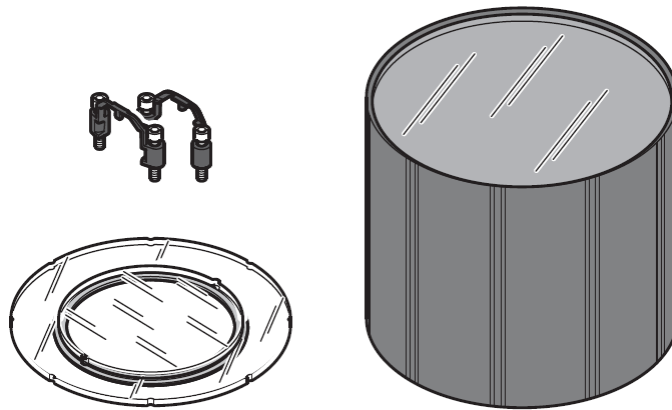

Polarizing filter for **LBC64x/65x**; including 2 attachments, 4 screws and extra-long hood)

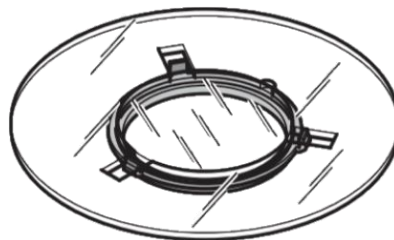

---

Polarizing filter for **LBC63x**; delivery includes only the filter

Polarizing filter is not available for LBC621.

---



### 7.1.2 IR filter



C-mount filter insert for increasing ambient light immunity when using infrared illumination.



---

Cannot be used with compact C-mount lens or S-mount lens, cannot be used with focal length 16 mm (part number 2079346).

**IR filter is not available for LBC621.**

---

### 7.1.3 Polarizing and IR filters benefits, image performance tuning

#### Polarizing filter

The polarizing filter provides favorable camera image results, eliminating any direct reflections. Although it may not positively influence the camera image when the ambient light conditions changes rapidly.

#### IR filter

The IR filter suppresses the changes of the ambient light conditions, esp. when the ambient light conditions varies to a great extent.



---

The **IR filter** must only be used in combination with the **IR illumination**. If combined with other IR light (illumination), then it may create unfavorable camera images.

---



---

We recommend using the **Polarizing filter**, when the camera is placed perpendicular to the inspected surface. Used particularly for code reading and OCR applications.

---





---

In order to eliminate direct reflections from the **internal illumination** of the camera, and at the same time, suppress the changes of the ambient light conditions, then it is highly recommended to utilize **both filters** in combination of the **IR illumination**.

---

## 7 APPENDICES

### 7.1.4 Polarizing filter influence on the camera image brightness

Camera image without polarizing filter	Camera image with polarizing filter
	
<p>The camera image without polarizing filter, creates reflection because of the internal illumination.</p>	<p>The camera image with polarizing filter, shows that the image brightness becomes clearly reduced, although a considerable exposure time value is required.</p>

### 7.1.5 IR filter influence on the camera image

Camera image results affected by **illumination in the worksite.**

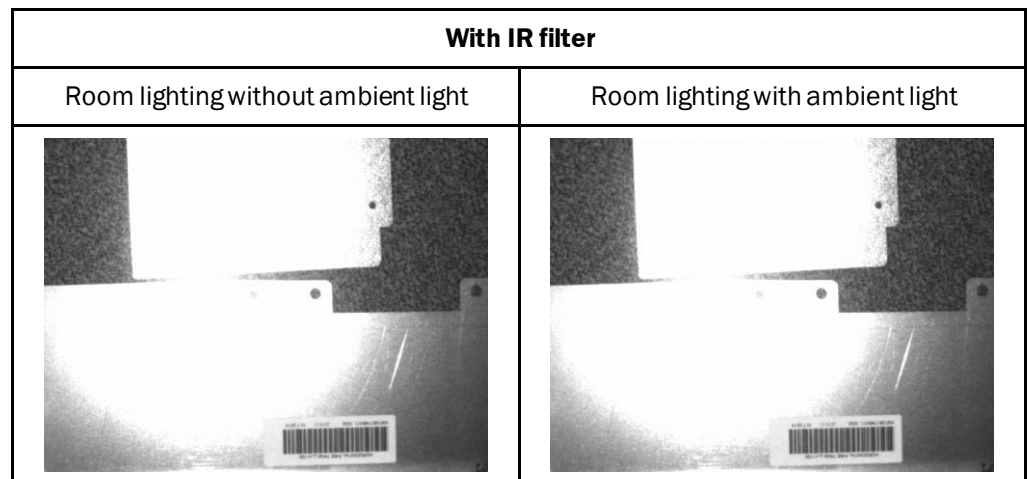
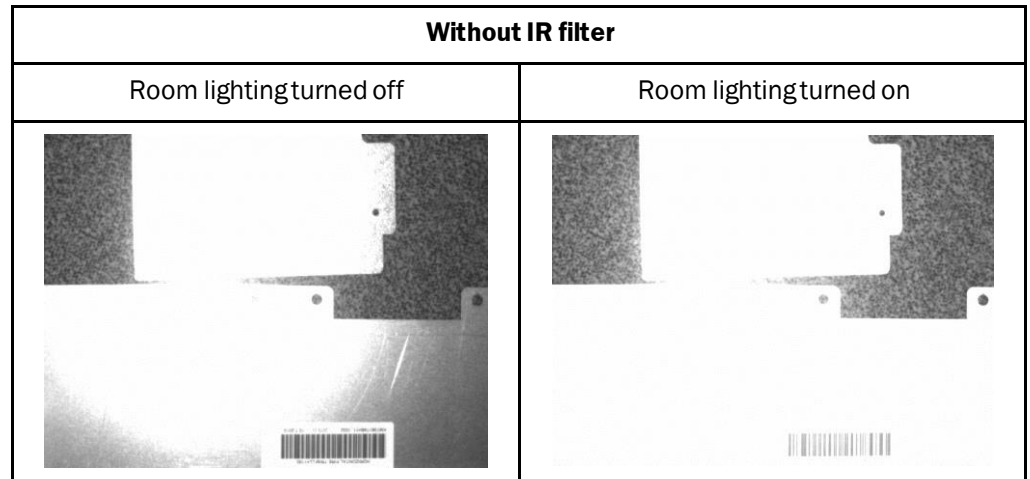

Unfavorable image quality when **combining IR filter** with white illumination

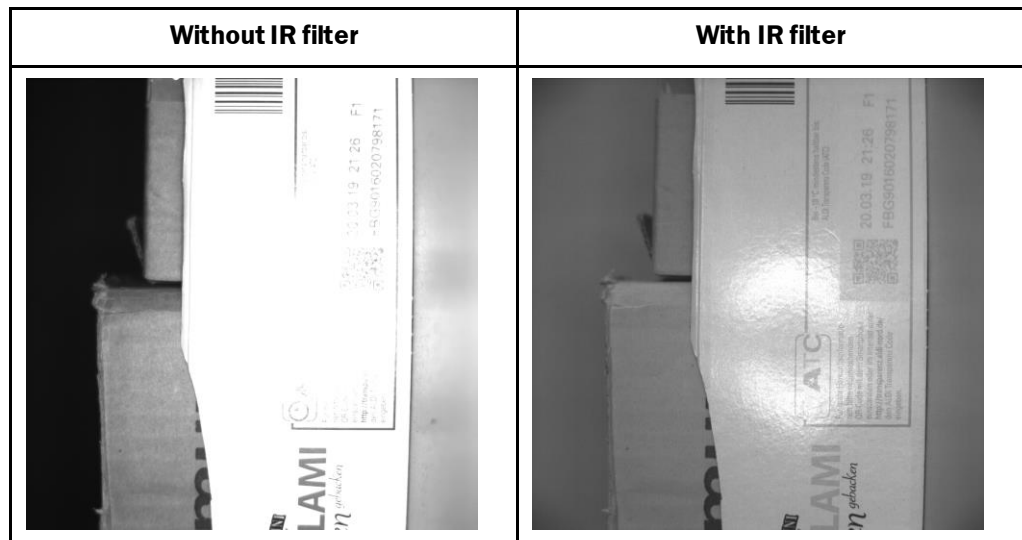

## 7.1.6 Polarizing and IR filters (example components)

**Camera components with Polarizing filter and white illumination**

<b>LBC654 with white illumination and polarizing filter</b>		
<b>Part number</b>	<b>Description</b>	<b>Detail</b>
1086947	LBC654	Label Checker P654 Flex
5327524	C-mount Lens 1" 25 mm	1" CCD lens 25mm C-mount
2075220	M12 5M0 17*0.14 ECO	Power cable with I/O
6049729	5M0 8*AWG26 M12/RJ45	GigE cable
2069007	Spacer	Spacer for mounting the integrable illumination, length: 51.3 mm
2074001	VI83I-WH1441M0	Internal illumination white, medium
2088230	Polarizing filters	Polarizing filter for LBC642/65x incl. hood
2069171	Mounting bracket set	Mounting bracket set consisting of angle and cooler for the camera
4077575	Micro SD card	SD card 2 GB

<b>Typical components LBC632 with white illumination and polarizing filter</b>		
<b>Part number</b>	<b>Description</b>	<b>Details</b>
1091688	LBC632	Label Checker P632 Flex C-mount
2079343	Compact lens C-mount 25MM	Compact lens C-mount 2/3" 25mm
2075220	M12 5M0 17*0.14 ECO	Power cable with I/O
6049729	5M0 8*AWG26 M12/RJ45	GigE cable
2078430	VI55I-WH1441M0	Internal illumination white medium
2079501	Distance bracket (medium)	Distance bracket and light extension connector for mounting integrable lighting
2088229	Polarizing filter	Polarizing filter for reducing disruptive light reflections
2079127	Lens protective hood 37.7MM	IP67 Lens protective hood medium
2076735	Mounting bracket set + cooling plate	Holder and cooler for the camera
4077575	Micro SD card	SD card 2 GB

**Camera components with IR illumination and IR filter**

<b>LBC654 with IR illumination and IR filter</b>		
<b>Part number</b>	<b>Description</b>	<b>Detail</b>
1086947	LBC654	Label Checker P654 Flex
5327524	Compact lens C-mount 1" 25 mm	1" CCD lens 25mm C-mount
2075220	M12 5M0 17*0.14 ECO	Power cable with I/O
6049729	5M0 8*AWG26 M12/RJ45	GigE cable
1047957	ICL300-F2020S01 <sup>2</sup>	External IR illumination
6030681	2M04*0,25M8	ICL cable, open end
2082987	Optical filter C-mount IR	C-mount filter insert for increasing ambient light immunity
2069171	Mounting brackets and plates	Mounting bracket set consisting of mounting angle, and cooler for the camera
4077575	Micro SD card	Micro SD card with 2 GB
2066565	Lens protective hood 74,5MM <sup>3</sup>	IP65 hood
<b>Option</b>		
2088230	Polarizing filter	Polarizing filter for LBC642/65x incl. hood

<sup>2</sup> IR illumination ICL (PN: 1047957) is NOT attached to the camera, needs an external holder

<sup>3</sup> Delivery of the polarizing filter for LBC64x/65x includes also extra-long hood, so is not necessary to offer PN: 2066565

<b>LBC632 Compact C-Mount with IR illumination and IR filter</b>		
1091688	LBC632	Label Checker P632 Flex C-mount
2079343	Compact lens C-mount 25MM	Compact lens C-Mount 2/3" 25mm
2075220	M12 5M0 17*0.14 ECO	Power cable with I/O
6049729	5M0 8*AWG26 M12/RJ45	GigE cable
2098834	VI55I-IR1435MO	Internal IR illumination medium
2079501	Spacer (medium)	Illumination holder and connector
2082987	Optical filter C-mount IR <sup>4</sup>	C-mount IR filter
2079127	Lens protective hood 37.7MM	IP67 hood
2076735	Mounting bracket set + cooling plate	Holder and cooler for the camera
4077575	Micro SD card	Micro SD card 2 GB
<b>Option</b>		
2088229	Polarizing filter	Polarizing filter for LBC63x

<sup>4</sup> IR filter cannot be used with Compact C-Mount 16 mm (PN: 2079346) neither with S-Mount lenses.

### Camera components with External IR illumination

<b>LBC632 C-Mount with IR illumination and IR filter</b>		
1091688	LBC632	Label Checker P632 Flex C-mount
5325405	Compact lens C-mount 25MM	Lens C-Mount 2/3" 25mm
2075220	M12 5M0 17*0.14 ECO	Power cable with I/O
6049729	5M0 8*AWG26 M12/RJ45	GigE cable
1047957	ICL300-F2020S01	External IR light
2096135	YF8U14-C60UA3M2A14	Cable for LBC631/632 and ICL directly into the camera
2081187	Mounting bracket	Mounting bracket for ICLxxx
2081544	Lens protective hood 69MM	IP67 hood
2082987	Optical filter C-mount IR	C-mount IR filter
2076735	Mounting bracket set + cooling plate	Mounting bracket set consisting of mounting angle, and cooler for the camera
4077575	Micro SD card	Micro SD card 2 GB
<b>Option</b>		
6030681	2M04*0,25M8	Illumination ICL cable, open end
2088229	Polarizing filter	Polarizing filter for LBC63x



## 7.2 Power cable wiring

Power cable PN: 2070425

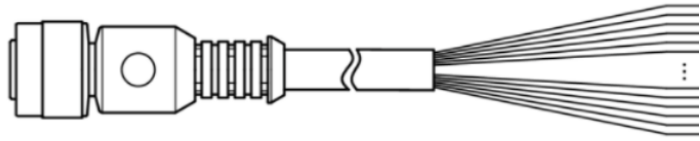

- |          |                 |                  |
|----------|-----------------|------------------|
| ① Blue   | ⑦ Black         | ⑬ White - green  |
| ② Brown  | ⑧ Gray          | ⑭ Brown - Green  |
| ③ Green  | ⑨ White - Black | ⑮ White - Yellow |
| ④ White  | ⑩ Violet        | ⑯ Yellow - Brown |
| ⑤ Pink   | ⑪ Gray - Pink   | ⑰ White - Gray   |
| ⑥ Yellow | ⑫ Red - Blue    |                  |

## 7.3 CDB650 connections pin assignment

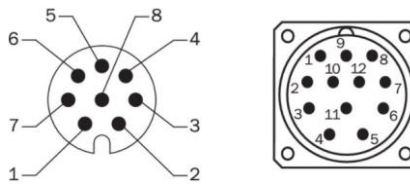

### Design, terminal assignment

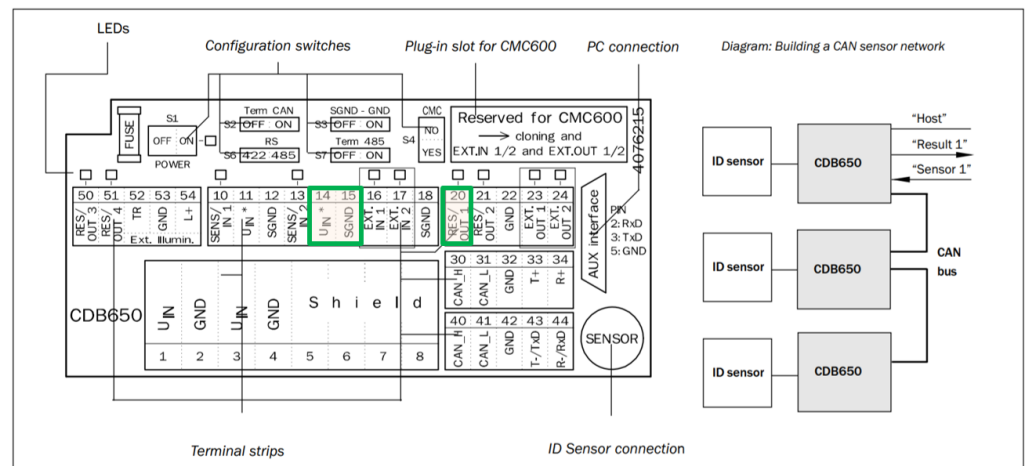

### 7.4 ICL300 connections pin assignment

 Front view	Pin	Wire color	Signal
	1	Brown	DC 24 V ± 20%
	2	White	Trigger
	3	Blue	GND
	4	Black	n.c.
	-	Metal braiding	Shield



Please be informed that the color of wires may differ. Always check the pin assignment in the description of cable being used.

## 7.5 Encoder DFS60B-S1PA10000 pinout

### Cable 8-wire

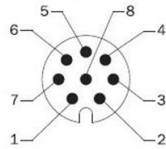

View of M12 male device connector on encoder

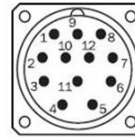

View of M23 device connector on encoder

PIN, 8-pin, M12 male connector	PIN, 8-pin, M23 male connector	Colors of the wires for encoders with cable outlet	HTL signal	Sin/cos 1.0 V <sub>SS</sub>	Explanation
1	6	Brown	$\bar{A}$	COS-	Signal wire
2	5	White	A	COS+	Signal wire
3	1	Black	$\bar{B}$	SIN-	Signal wire
4	8	Pink	B	SIN+	Signal wire
5	4	Yellow	$\bar{Z}$	$\bar{Z}$	Signal wire
6	3	Violet	Z	Z	Signal wire
7	10	Blue	GND	GND	Ground connection of the encoder
8	12	Red	+U <sub>s</sub>	U <sub>s</sub>	Supply voltage (volt-free to housing)
-	9	-	n.c.	n.c.	Not assigned
-	2	-	n.c.	n.c.	Not assigned
-	11	-	n.c.	n.c.	Not assigned
-	7 <sup>5</sup>	-	0-SET <sup>Error! Bookmark</sup>	n.c.	Set zero pulse <sup>Error! Bookmark</sup> not defined.

<sup>5</sup> For electrical interfaces only: M, U, V, and W with 0-SET function on PIN 7 on M23 male connector. The 0-SET input is used to set the zero pulse on the current shaft position. If the 0-SET input is

## 7 APPENDICES

---

			not defined.		
Screen	Screen	Screen	Screen	Screen	Screen connected to housing on encoder side. Control ground on control side.

---

connected to  $U_s$  for longer than 250 ms after it had previously been assigned for at least 1,000 ms or had been connected to the GND, the current position of the shaft is assigned to the zero pulse.

## 7.6 Trigger and external illumination connection

**Trigger connection** on CDB650 pin 10 - sensor 1 IN, pin 12 - SGND

**External illumination connection** (e.g. ICL300) via DO4 on CDB650 - 4-pin M8 cable PN: 6030681

- cable brown 24 V – on CDB650 pin 14, Uin
- cable blue GND – on CDB650 pin 15, GN
- cable white trigger – on CDB650 pin 21, RES / OUT 2 (LBC DO4)
- cable black not used – on CDB650 not connected
- switch S3 SGND - GND on CDB650 must be ON (on GND at right)



You may use 2 external illuminations simultaneously, using the LBC63x. One connected via DI4 and second connected via external illumination connector. It is possible to use internal illumination in combination with these 2 external lights.

**The LBC621 and LBC64x/65x, can only use one external light connected via DI4.**

## 7.7 Encoder connection (directly or via CDB650)

The supported encoder connections of Label Checker are the incremental encoders with HTL logic. (Maximum 300 kHz frequency (described connection for DFS60B-S1PA10000), input voltage 24 V.



Please be informed that LBC does not support TTL logic.

### Label Checker connector pinout



Please find the pinout connector assignment for pin 13 (LBC631/LBC632) on [subsection 3.4.2](#).

PIN	17 – pin M12 male connector, A-coded
13	Result 1, switching output

The encoder pin 2 (HTL signal “A”) is connected directly to the Label Checker on pin 13 (DOS, Result 1 switching I/O) or via CDB650 on pin 20.

Encoder pin 7 (GND) is connected directly to the Label Checker on pin 1 or 9 via CDB650 on pin 15.

Encoder pin 8 is connected to the Label Checker pin 2 (+24 V) or via CDB650 on pin 14.

### 7.8 LBC621 accessories

#### **Dome reflector**

PN: 2063093

In order to achieve the best results in OCR and Code reading, it is best to place the camera perpendicularly to destination surface/FOV, so that the image will be minimally/less distorted. When using internal illumination of the camera, reflections in the middle of the image may occur, especially on glossy and bent surfaces. Dome reflector can be very helpful on eliminating these type of reflections, where it homogenously distributes the light on the entire FOV. Higher exposure settings is necessary when using the dome.

It has similar effect to the polarizing filter mentioned in [7.1.1 Polarizing filter](#) for LBC621 is not available though. In other hand, dome reflector is available only for LBC621.

**Without dome reflector**

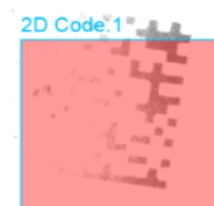

**With dome reflector**

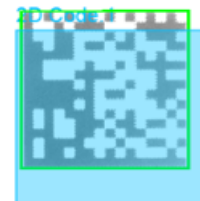

Please refer to this link for further information:

<https://www.sick.com/cz/en/dome-accessories/p/p291544>

#### **Protective shield**

PN: 2065807

When the camera is used in harsh environment, the front camera window can be protected using the protective shield.

Please refer to this link for further information:

<https://www.sick.com/cz/en/protective-screen/p/p329759>

## 7.9 Illumination color influence

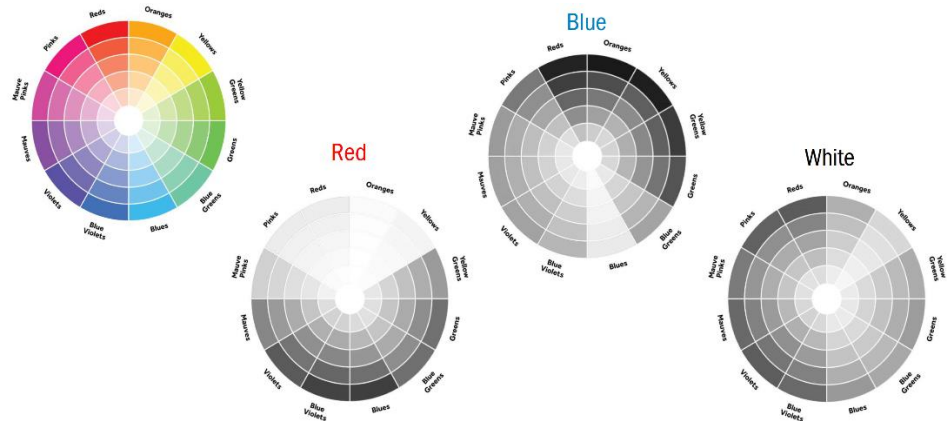

### WHITE...

- Is the all-purpose version due to widest spectrum
- Is most suitable for text or code printed on cardboard boxes
- Suits best for presentation camera applications as most people feel white light is least harmful

### BLUE...

- Is the perfect choice if maximum optical DOF is required ( $f = >11...16$ )
- Offers best performance if the pixel resolution is challenging (1D code  $< 1.5$  ppm & 2D code  $< 2.0$ ppm, ppm – pixels per module)
- Is not well-suitable for colored text or code printed on cardboard boxes as the brown background turns black

### RED...

- Is used if mixed labels with white, yellow and red background need to be read
- Can be used if black text or code is printed on cardboard boxes

### Infra-Red (IR)...

- Suits best when people work close to cameras and shall not be disturbed by flashing light – IR is invisible
- Has highest ambient light resistance due to daylight block filter usage
- Delivers lower text and code resolution (1D  $< 2$  ppm & 2D  $< 3$ ppm)
- Some material and even printed text or code is sometimes invisible to IR light

### 7.10 Technical data

Type	LBC631	LBC632	LBC642	LBC652	LBC654	LBC621
<i>Features</i>						
<b>Task</b>	OCR, OCV, bar code & 2D code reading, Advanced inspections					
<b>Sensor</b>	CMOS matrix sensor, grayscale values					
<b>Optical focus</b>	Adjustable focus (manually)					
<b>Working distance</b>						300 mm ... 1,500 mm 2)
<b>Light source</b>	Illumination LEDs: (to be ordered separately as accessories)					LED, invisible, infrared or Red/Blue
Internal lighting						
Adjustment aid	Aiming laser: visible red light ( $\lambda = 630 \dots 680 \text{ nm}$ )					
Feedback spot						LED, Visible, green, 525 nm, $\pm 15 \text{ nm}$
<b>Laser class</b>	1, complies with 21 CFR 1040.10 except for the tolerance according to "Laser Notice No. 50" from June 24, 2007 (IEC 60825-1:2014, EN 60825-1:2014).					
<b>Spectral range</b>	Approx. 400 nm ... 900 nm					
<b>Lens</b>	C-mount (to be ordered separately as accessories)					Integrated
<i>Performance</i>						
<b>Sensor resolution</b>	1,280 px x 1024 px (1.3 Mpixel)	1,600 px x 1,200 px (1.9 Mpixel)	1,600 px x 1,088 px (1.7 Mpixel)	2,048 px x 1,088 px (2.1 Mpixel)	2,048 px x 2,048 px (4.2 Mpixel)	1,280 px x 1,024 px (1.3 Mpixel)
<b>Optical format</b>	1/1.8"		1"			
<b>Bar codes types</b>	2/5 Industrial, 2/5 Interleaved, Codabar, Code 39, Code 93, Code 128; EAN-8, EAN-13, Pharma Code					
<b>2D code types</b>	Data Matrix ECC200, QR code, Micro QR code, PDF417, Aztec Code					
<b>OCR/OCV fonts</b>	Universal, Industrial, Document, Dot Print, Pharma, OCR-A, OCR-B, Arabic numbers					
<i>Interface</i>						
<b>Serial</b>	✓, RS-232, RS-422					
Data transmission	300 Baud ... 115.2 kBaud					
<b>Ethernet</b>	✓, TCP/IP					
Function	FTP, HTTP					



Data transmission rate	10/100/1,000 Mbit/s			10/100 MBit/s
<b>Operator interfaces</b>	Web server			
<b>Data storage and retrieval</b>	Image and data logging via micro SD memory card and external FTP			
<b>Output current</b>	≤ 100 mA			
<b>Operating elements</b>	Two buttons; aiming laser, snap shot, strobe			
<b>Optical indicators</b>	11 LEDs (5 x status displays, 5x LED bar graph, 1 green/ red feedback spot)	21 LEDs (10 x status display, 10 x LED bar graph, 1 green feedback spot)	16 LEDs (5 status displays, 10 LED bar graphs, 1 green/ red feedback spot)	
<b>Acoustic indicators</b>	Beeper			
<i>Mechanics/electronics</i>				
<b>Connections</b>	1 x M12, 17-pin male connector (serial, I/ Os, voltage supply)			
	1 x M8, 4-pin female connector (USB, not used)			
	2 x M12, 8-pin female connector (Gigabit Ethernet, only one connection used)			
	1 x M12, 4-pin male connector (external illumination)			
<b>Supply voltage</b>	12 V DC ... 24 V DC, ± 20 %			
<b>Power consumption</b>	Typ. 10 W ± 20 %			Typ. 4 W
<b>Enclosure rating</b>	IP67	IP65		
<b>Protection class</b>	III (EN 60950-1 (2014-08))			
<b>Housing material</b>	Aluminum die cast			
<b>Window material</b>	PMMA <sup>6</sup>	Glass		PMMA
<b>Weight</b>	430 g	635 g	635 g	635 g
<b>Dimension</b>	108 mm x 63 mm x 46 mm <sup>7</sup>	142 mm x 90 mm x 46 mm <sup>8</sup>		71 mm x 43 mm x 35.6 mm <sup>9</sup>
<b>Optic</b>	Exchange (C-mount) <sup>10</sup>			

<sup>6</sup> When using optics cover and male connector

<sup>7</sup> Only housing without lens and protective cover

<sup>8</sup> Only housing without lens and protective hood.

<sup>9</sup> Only housing without lens and protective hood.

<sup>10</sup> Order separately as an accessory.

<b>Ambient data</b>	
<b>Shock load</b>	EN 60068-2-27:2009-05
<b>Vibration load</b>	EN 60068-2-6:2008-02
<b>Ambient operating temperature</b>	0 °C ... +50 °C
<b>Ambient storage temperature</b>	-20 °C ... +70 °C <sup>11</sup>

<b>Classification</b>	
<b>ECl@ss 5.0</b>	27310205
<b>ECl@ss 5.1.4</b>	27310205
<b>ECl@ss 6.0</b>	27310205
<b>ECl@ss 6.2</b>	27310205
<b>ECl@ss 7.0</b>	27310205
<b>ECl@ss 8.0</b>	27310205
<b>ECl@ss 8.1</b>	27310205
<b>ECl@ss 9.0</b>	27310205
<b>ETIM 5.0</b>	EC001820
<b>ETIM 6.0</b>	EC001820
<b>UNSPSC 16.0901</b>	43211731

<sup>11</sup> Permissible relative air humidity. 0 % ... 90 % (non-condensing).

## 7.11 Additional accessories

For additional accessories such as brackets and cables, please contact your nearest SICK company agent or representative.

You can find the additional accessories and further documentation on-line.

- ▶ See: [www.sick.com](http://www.sick.com)
- ▶ Select your country and language.
- ▶ Enter the sensor's type designation or part number into the search field.
- ▶ Select the required sensor.
- ▶ All documentation regarding recommended and optional accessories can be found under accessories. Other downloadable content relating to the sensor can be found under Downloads.

You can visit and find the accessories at: [www.sick.com](http://www.sick.com)

## 7.12 Ordering information

Type	Part number	Sensor resolution
<b>LBC621-17RB</b>	1115469	1,280 px x 1,024 px (1.3 Mpixel)
<b>LBC621-10RB</b>	1115468	1,280 px x 1,024 px (1.3 Mpixel)
<b>LBC621-17NIR</b>	1115470	1,280 px x 1,024 px (1.3 Mpixel)
<b>LBC631</b>	1091689	1,280 px x 1,024 px (1.3 Mpixel)
<b>LBC632</b>	1091688	1,600 px x 1,200 px (1.9 Mpixel)
<b>LBC642</b>	1091687	1,600 px x 1,088 px (1.7 Mpixel)
<b>LBC652</b>	1091686	2,048 px x 1,088 px (2.1 Mpixel)
<b>LBC654</b>	1086947	2,048 px x 2,048 px (4.2 Mpixel)

### Australia

Phone +61 3 9457 0600  
1800 334 802 – toll free  
E-Mail sales@sick.com.au

### Austria

Phone +43 22 36 62 28 8-0  
E-Mail office@sick.at

### Belgium/Luxembourg

Phone +32 2 466 55 66  
E-Mail info@sick.be

### Brazil

Phone +55 11 3215-4900  
E-Mail marketing@sick.com.br

### Canada

Phone +1 905 771 14 44  
E-Mail information@sick.com

### Czech Republic

Phone +420 234 719 500  
E-Mail sick@sick.cz

### Chile

Phone +56 2 2274 7430  
E-Mail info@schadler.com

### China

Phone +86 20 2882 3600  
E-Mail info.china@sick.net.cn

### Denmark

Phone +45 45 82 64 00  
E-Mail sick@sick.dk

### Finland

Phone +358-9-2515 800  
E-Mail sick@sick.fi

### France

Phone +33 1 64 62 35 00  
E-Mail info@sick.fr

### Germany

Phone +49 211 5301-301  
E-Mail info@sick.de

### Hong Kong

Phone +852 2153 6300  
E-Mail ghk@sick.com.hk

### Hungary

Phone +36 1 371 2680  
E-Mail office@sick.hu

### India

Phone +91 22 4033 8333  
E-Mail info@sick-india.com

### Israel

Phone +972 4 6881000  
E-Mail info@sick-sensors.com

### Italy

Phone +39 02 274341  
E-Mail info@sick.it

### Japan

Phone +81 3 5309 2112  
E-Mail support@sick.jp

### Malaysia

Phone +6 03 8080 7425  
E-Mail enquiry.my@sick.com

### Mexico

Phone +52 472 748 9451  
E-Mail mario.garcia@sick.com

### Netherlands

Phone +31 30 2044 000  
E-Mail info@sick.nl

### New Zealand

Phone +64 9 415 0459  
0800 222 278 – toll free  
E-Mail sales@sick.co.nz

### Norway

Phone +47 67 81 50 00  
E-Mail sick@sick.no

### Poland

Phone +48 22 539 41 00  
E-Mail info@sick.pl

### Romania

Phone +40 356 171 120  
E-Mail office@sick.ro

### Russia

Phone +7 495 775 05 30  
E-Mail info@sick.ru

### Singapore

Phone +65 6744 3732  
E-Mail sales.gsg@sick.com

### Slovakia

Phone +421 482 901201  
E-Mail mail@sick-sk.sk

### Slovenia

Phone +386 591 788 49  
E-Mail office@sick.si

### South Africa

Phone +27 11 472 3733  
E-Mail info@sickautomation.co.za

### South Korea

Phone +82 2 786 6321  
E-Mail info@sickkorea.net

### Spain

Phone +34 93 480 31 00  
E-Mail info@sick.es

### Sweden

Phone +46 10 110 10 00  
E-Mail info@sick.se

### Switzerland

Phone +41 41 619 29 39  
E-Mail contact@sick.ch

### Taiwan

Phone +886 2 2375-6288  
E-Mail sales@sick.com.tw

### Thailand

Phone +66 2645 0009  
E-Mail Ronnie.Lim@sick.com

### Turkey

Phone +90 216 528 50 00  
E-Mail info@sick.com.tr

### United Arab Emirates

Phone +971 4 88 65 878  
E-Mail info@sick.ae

### United Kingdom

Phone +44 1727 831121  
E-Mail info@sick.co.uk

### USA

Phone +1 800 325 7425  
E-Mail info@sick.com

### Vietnam

Phone +84 945452999  
E-Mail Ngo.Duy.Linh@sick.com

Further locations at [www.sick.com](http://www.sick.com)