

**Model OR8EFG
KCI Filling type ORP Sensor**

IM 12C07J01-01E



INTRODUCTION

This manual covers the OR8EFG KCl Filling type ORP Sensor.

Other related items are described in the following manuals.

Model	Title	IM No.
PH8HG	Guide-pipe Holder	IM 12B7M2-01E
PH8HF, PH8HFF	Flow-Through Type Holder	IM 12B07N01-01E
PH8HS, PH8HSF	Submersion Type Holder	IM 12B07M01-01E
HH350G	Well Bucket Type Holder	IM 19H1B1-01E
PB350G	Float Type Holder	IM 19H1E1-01E
PB360G	Vertical Type Float Holder	IM 19H1E2-01E
FLXA402	4-Wire Converter	IM 12A01F01-02EN IM 12A01F02-01EN etc.
PH450G	pH/ORP Converter	IM 12B07C05-01E
PH202G, S	pH/ORP Transmitter	IM 12B07D02-01E
PH202SJ	TIIS Intrinsic safe pH/ORP Transmitter	IM 12B07D02-11E
FLXA202, FLXA21	2-Wire Liquid Analyzer	IM 12A01A02-01E
WTB10-PH□	Terminal Box	IM 19D01B01-01E
OR8TBG	Terminal Box	IM 12C04W01-01E
OR8AX	Accessories for ORP Meter	IM 12C04W02-01E

◆ For the safe use of this equipment

■ Notes on Handling User's Manuals

- Please hand over the user's manuals to your end users so that they can keep the user's manuals on hand for convenient reference.
- Please read the information thoroughly before using the product.
- The purpose of these user's manuals is not to warrant that the product is well suited to any particular purpose but rather to describe the functional details of the product.
- No part of the user's manuals may be transferred or reproduced without prior written consent from YOKOGAWA.
- YOKOGAWA reserves the right to make improvements in the user's manuals and product at any time, without notice or obligation.
- If you have any questions, or you find mistakes or omissions in the user's manuals, please contact our sales representative or your local distributor.

■ Safety, Protection, and Modification of the Product

- In order to protect the system controlled by the product and the product itself and ensure safe operation, observe the safety precautions described in this user's manual. We assume no liability for safety if users fail to observe these instructions when operating the product.
- If this instrument is used in a manner not specified in this user's manual, the protection provided by this instrument may be impaired.
- If any protection or safety circuit is required for the system controlled by the product or for the product itself, prepare it separately.
- Be sure to use the spare parts approved by Yokogawa Electric Corporation (hereafter simply referred to as YOKOGAWA) when replacing parts or consumables.
- Modification of the product is strictly prohibited.
- The following safety symbols are used on the product as well as in this manual.



WARNING

This symbol indicates that an operator must follow the instructions laid out in this manual in order to avoid the risks, for the human body, of injury, electric shock, or fatalities. The manual describes what special care the operator must take to avoid such risks.



CAUTION

This symbol indicates that the operator must refer to the instructions in this manual in order to prevent the instrument (hardware) or software from being damaged, or a system failure from occurring.

CAUTION

This symbol gives information essential for understanding the operations and functions.

NOTE

This symbol indicates information that complements the present topic.

■ Warning and Disclaimer

The product is provided on an "as is" basis. YOKOGAWA shall have neither liability nor responsibility to any person or entity with respect to any direct or indirect loss or damage arising from using the product or any defect of the product that YOKOGAWA can not predict in advance.

◆ After-sales Warranty

- **Do not modify the product.**

- **During the warranty period, for repair under warranty consult the local sales representative or service office. Yokogawa will replace or repair any damaged parts. Before consulting for repair under warranty, provide us with the model name and serial number and a description of the problem. Any diagrams or data explaining the problem would also be appreciated.**
 - If we replace the product with a new one, we won't provide you with a repair report.
 - Yokogawa warrants the product for the period stated in the pre-purchase quotation. Yokogawa shall conduct defined warranty service based on its standard. When the customer site is located outside of the service area, a fee for dispatching the maintenance engineer will be charged to the customer.

- **In the following cases, customer will be charged repair fee regardless of warranty period.**
 - Failure of components which are out of scope of warranty stated in instruction manual.
 - Failure caused by usage of software, hardware or auxiliary equipment, which Yokogawa Electric did not supply.
 - Failure due to improper or insufficient maintenance by user.
 - Failure due to modification, misuse or outside-of-specifications operation which Yokogawa does not authorize.
 - Failure due to power supply (voltage, frequency) being outside specifications or abnormal.
 - Failure caused by any usage out of scope of recommended usage.
 - Any damage from fire, earthquake, storms and floods, lightning, disturbances, riots, warfare, radiation and other natural changes.

- **Yokogawa does not warrant conformance with the specific application at the user site. Yokogawa will not bear direct/indirect responsibility for damage due to a specific application.**

- **Yokogawa Electric will not bear responsibility when the user configures the product into systems or resells the product.**

- **Maintenance service and supplying repair parts will be covered for five years after the production ends. For repair for this product, please contact the nearest sales office described in this instruction manual.**

Model OR8EFG KCl Filling type ORP Sensor

IM 12C07J01-01E 8th Edition

CONTENTS

- ◆ INTRODUCTION.....i
- ◆ For the safe use of this equipment.....ii
- ◆ After-sales Warrantyiii
- 1. Specification 1-1
 - 1.1 Standard Specifications..... 1-1
 - 1.2 Model and Suffix codes..... 1-3
 - 1.3 External Dimensions 1-5
- 2. Installation..... 2-1
 - 2.1 Preparation for Installation 2-1
 - 2.1.1 Unpacking and Inspection 2-1
 - 2.1.2 Mounting Indicator Electrode 2-1
 - 2.1.3 Mounting Liquid Junction 2-2
 - 2.1.4 Installing Holder 2-2
 - 2.1.5 Installing Associated Instruments 2-2
 - 2.2 Requirements for mounting the ORP Sensor..... 2-2
 - 2.2.1 In case of installing the PH8HG Guide-pipe Holder 2-2
 - 2.2.2 Installing Sensor in PH8HS Submersion Holder 2-4
 - 2.2.3 Installing Sensor in Flow-through Holder..... 2-7
 - 2.3 ORP Sensor Cable Wiring Procedure..... 2-9
 - 2.3.1 Processing of Cable Inlet Hole..... 2-9
 - 2.3.2 Connecting Sensor Cable..... 2-9
 - 2.3.3 Connecting Sensor Cable to Two-wire ORP Transmitter 2-10
 - 2.3.4 Connecting Sensor Cable to Four-wire ORP Converter 2-11
- 3. Maintenance on operation..... 3-1
 - 3.1 Operation and Periodic Maintenance 3-1
 - 3.1.1 Calibrating ORP Sensor Using Checking Solutions 3-1
 - 3.1.2 Pressurizing Reserve Tank 3-1
 - 3.1.3 Replenishment of KCl Solution 3-2
 - 3.1.4 Cleaning Indicator Electrode and Liquid Junction 3-3
 - 3.2 Replacing Consumable Parts..... 3-4
 - 3.2.1 Replacing Liquid Junction 3-4
 - 3.2.2 Replacing O-rings for Indicator Electrode..... 3-4
- Customer Maintenance Parts List..... CMPL12C03J01-01E
- Revision Informationi

1. Specification

The Model OR8EFG KCl filling type ORP Sensor permits stable ORP measurement even for solutions having comparatively severe properties.

This sensor can be mounted on either an PH8HF flow-through holder or an PH8HS submersion holder, or its can be used alone suspended in the solution (a maximum depth of 3 meters).

1.1 Standard Specifications

Measurement: Oxidation-reduction potential of a solution

Measurement principle: Metallic electrode method

Measuring range: -1500 to 1500 mV

Installation: Mounting in PH8HS submersion holder
 Mounting in PH8HG guide-pipe holder
 Mounting in PH8HF flow-through holder

Note: If any of the following solutions are measured, install the sensor either in a flow-through or submersion holder.

- When the solution temperature exceeds 80°C.
- When the pH of the solution is 2 or less or 12 or greater.
- When a strong acid solution is to be measured (e.g., aqua regia, chromic acid, hypochlorous acid or perchloric acid, etc.).
- When the solution contains corrosive gases (e.g., ammonia, chlorine, hydrogen sulfide, etc).
- When the solution contains a small percentage of organic solvent or oil.

Solution temperature: -5 to 105°C
 when mounted in PH8HG guide-pipe holder: -5 to 80°C
 when mounted in PH8HS, PH8HF holder, see Table 1.

Table 1. Process Temperature Range

Holder Type	Holder Material	Cleaner	Solution pH Range	Solution Temperature (°C)
Guide-pipe (PH8HG)	PVC	None	2 to 12	-5 to 50
	PP			-5 to 80
Submersion (PH8HS)	PP	None	0 to 14	-5 to 100
		Provided		-5 to 80
	SS (*2)	None		-5 to 100
		Provided		-5 to 80
Flow-through (PH8HF) (*1)	PP	None	-5 to 80	
		Provided	-5 to 80	
	SS (*2)	None	-5 to 105	
		Provided	-5 to 80	
Suspension (HH350G)	SS (*2)	None, Provided	-5 to 80	
Float (PB350G, PB360G)	PP, SS (*2)	None	-5 to 50	

Note: PVC: Rigid Polyvinyl, PP: Polypropylene, SS: Stainless Steel.

*1: For flow-through types, refer also to the solution temperature and pressure graph (in notes following Model and Suffix code table for flow-through type holders).

*2: Solutions with normal pH ranges of 3 to 14 are recommended for stainless steel (316 SS).

Solution pressure : Under atmospheric pressure to 10 kPa (General purpose)
 (See Table 2 when using holder)
 Atmospheric pressure to 500 kPa (Medium pressure tank)
 (See Table 2 when using holder)

Table 2. Process Pressure Range

Holder	Process Pressure Range
Submersion	Atmospheric pressure (Submersion depth: 3 m max.)
Guide-pipe Suspension Float	Atmospheric pressure (Submersion depth: 3 m max.)
Flow-through (*1)	Atmospheric pressure to 10 kPa Atmospheric pressure to 500 kPa when medium pressure reserve tank used.

*1: For flow-through types, refer also to the solution temperature and pressure diagram of Holder IM.

Operating solution depth : 3 m water pressure (max.) under atmospheric pressure
 Solution flow velocity : 2 m/s max.
 Solution flow rate : 3 to 11 L/min
 (when the sensor is installed in a flow-through type holder).

Wetted part materials:

- Body; Ryton (PPS resin), platinum-glass or gold-epoxy resin, titanium or Hastelloy C, Ceramics or Fluororesin (PTFE), Fluoro rubber (FKM)
- Cable; Chlorinated polyethylene rubber (Cable sheath)
- KCl tube; Heat-resistant soft PVC (General purpose), Polyethylene (Medium pressure)

Weight:

- Sensor; Approx. 0.4 kg (Body)
- KCl Tank; Approx. 0.3 kg (General purpose)
 Approx. 1 kg (Medium pressure)

KCl solution consumption: Pressurized with 10 kPa

- 3 mL/day (max.) (Junction for general use)
- 20 mL/day (max.) (PTFE junction)

CAUTION



Select the material of wetted parts with careful consideration of process characteristics. Inappropriate selection may cause leakage of process fluids, which greatly affects facilities. Considerable care must be taken particularly in the case of strongly corrosive process fluid such as hydrochloric acid, sulfuric acid, hydrogen sulfide, and sodium hypochlorite. If you have any questions about the wetted part construction of the product, be sure to contact Yokogawa.

1.2 Model and Suffix codes

● ORP Sensor

Model	Suffix Code	Option Code	Description
OR8EFG	KCl Filling Type ORP Sensor
Electrode	-AU -PT	Gold Platinum
Cable Length and KCl Tube Length	-03 -05 -07 -10 -15 -20	3 m 5 m 7 m 10 m 15 m 20 m
KCl Reserve Tank (*1)	-TT1 -TT2 -TN1 -TN2	For general purpose (250 mL solution inlet) For medium pressure (*2) For maintenance (for TT1) For maintenance (for TT2)
Measuring System	-N -E -F -B -G	For OR200,OR400 (*3) For FLXA402,PH202,FLXA202,FLXA21 (*4) For FLXA202,FLXA21 (*5) For OR100 (*6) For FLXA402, PH450G,PH202/TB (*7)
Style		*A	Style A
Option	Special junction	/TF	PTFE junction (*8)

- *1: 2-inch pipe mounting bracket is supplied with TT1, TT2.
Only a supply tube, but no KCl solution, is supplied with TN1 and TN2.
Since a KCl solution is not supplied with TT2, arrange it from among accessories or auxiliary parts.
- *2: Prepare an air pressure regulator as shown in the diagram below when the medium-pressure reserve tank is used.
To ORP Sensor, Regulator, (to be prepared separately)

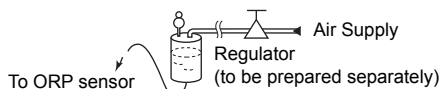

- *3: Mark band is shown by alphanumeric and fork terminals are used.
- *4: Mark band is shown by numeral and pin terminals are used.
- *5: Mark band is shown by numeral and M4 ring terminals are used.
When terminal box is used, select WTB10-PH5.
- *6: The tag which indicated the color, the sign, and the number is attached to the cable of a sensor.
- *7: Mark band is shown by numeral and M3 ring terminals are used.
When terminal box is used, select WTB10-PH3.
- *8: Choose when using in the heavily contaminated application.

● Accessories

Model	Suffix Code	Option Code	Description
OR8AX	Accessories for ORP meter (*1)
Style		*A	Style A
Option (*2)		/STD /KCLL /KCLP /TMP	Sensor stand (with mounting bracket for 2-inch pipe) KCl solution (one 250 mL polyethylene bottle) KCl powder (three bags, 250 mL solution each) Thermometer (0 to 100°C)

- *1: Including the following:
Two 200 mL polyethylene cups
One cleaning bottle
One pack of quinhydrone reagent powder (three bags, 250 mL solution each)
One 250 mL polyethylene bottle
- *2: Either /KCLL or /KCLP is required for OR8EFG-□□-□□-TT2.

- Consumables

Part Name		Part Number	Remarks
Indicator electrode	Platinum	K9142TS	One for OR8ERG,OR8EFG
	Gold	K9142TT	One for OR8ERG,OR8EFG
Junction		K9142TH	One for OR8ERG,OR8EFG
		K9142HW	One for OR8EFG/TF
KCl solution (3.3mol/L)		K9084LP	Six 250 mL polyethylene bottles
KCl powder (for OR8EFG)		K9020XU	8 bags, each for preparation of 250mL
Reagent for check	Quinhydrone	K9024EC	3 bags, each for preparation of 250mL
	Iron	K9024ED	3 bags, each for preparation of 250mL

1.3 External Dimensions

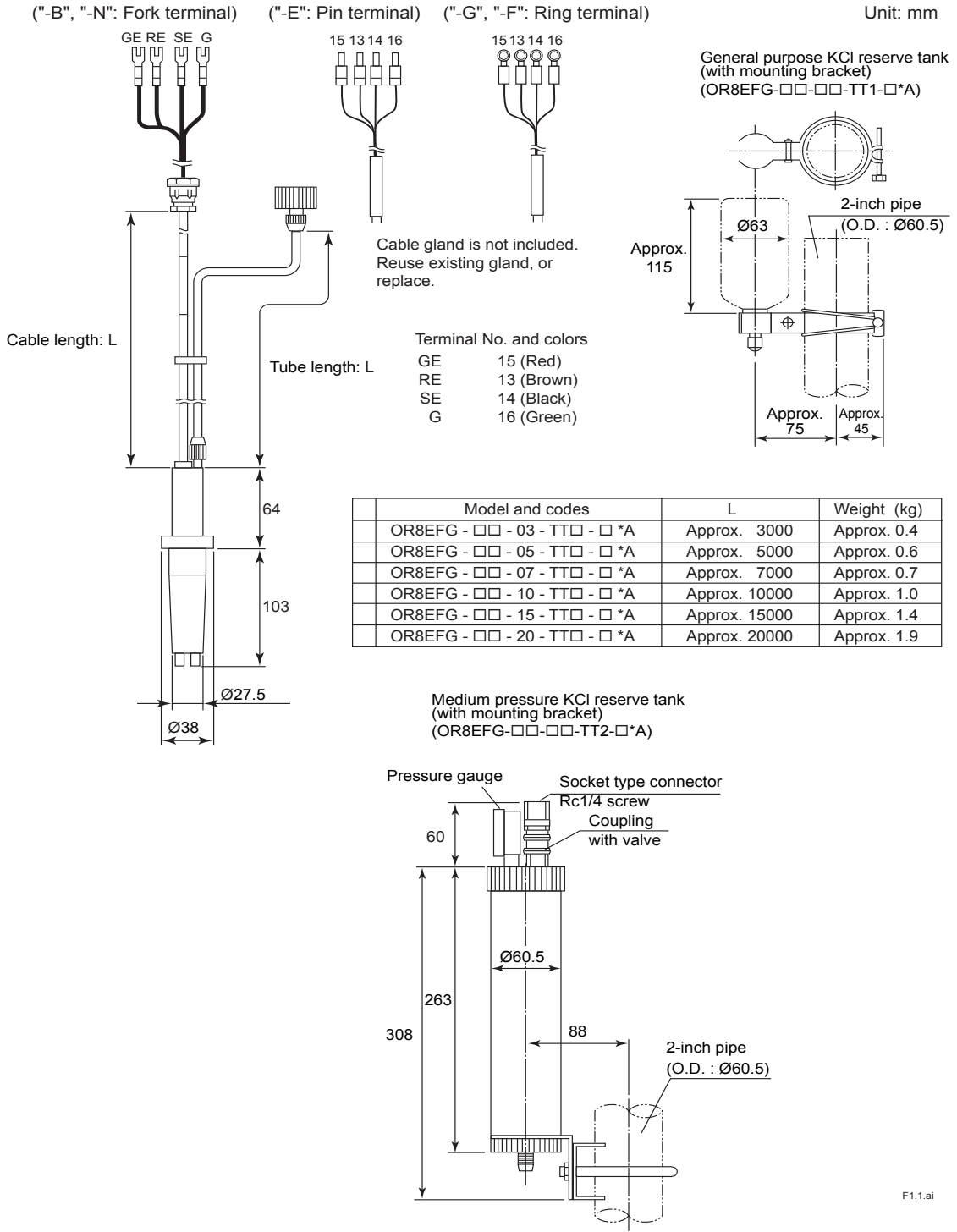

Figure 1.1 OR8EFG Filling type ORP Sensor

2. Installation

2.1 Preparation for Installation

2.1.1 Unpacking and Inspection

The Model OR8EFG ORP Sensor is well packed so as to prevent damage during shipment. After removing the sensor from its shipping container, visually check the sensor for damage.

NOTE

1. When delivered, the "indicator electrode" and the "liquid junction" are packed separate from the sensor body.
2. So that the "liquid junction" does not dry out do not take unpack its at this time.

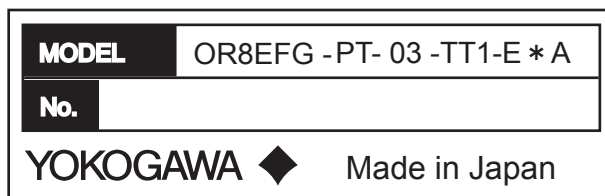

Figure 2.1 An Example of Model Number Entering to Nameplate

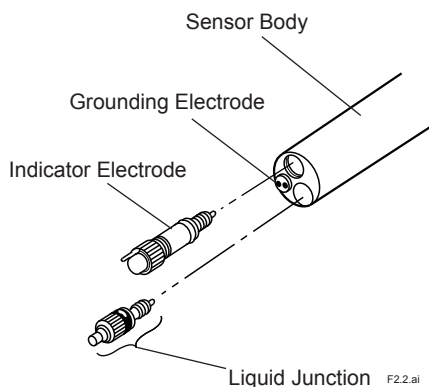

Figure 2.2 Names of OR8EFG ORP Sensor Components

2.1.2 Mounting Indicator Electrode

Mount the indicator electrode on the sensor body as per the following procedure:

- (1) Peel off the seal covering to the electrode mounting hole on the sensor body.
- (2) Take the indicator electrode out of its bag and check to confirm that there is no dirt or scratches on the O-ring that might affect the seal.
- (3) Mount the indicator electrode in the sensor body. Insert the electrode in the electrode mounting hole and screw the electrode clockwise until the O-ring fits tightly in the hole.

NOTE

Be careful not to allow water droplets to flow into the electrode mounting hole. If water gets into the hole, wipe it dry, or insulation resistance may be affected.

2.1.3 Mounting Liquid Junction

The liquid junction is mounted in the sensor body when the KCl solution is poured into the sensor body. Refer to Section 2.2.

2.1.4 Installing Holder

Usually, the ORP Sensor is suspended in a guide pipe or installed in a flow-through or submersion holder. First install the holder.

2.1.5 Installing Associated Instruments

Make sure that the associated instrument (a ORP transmitter/converter or a junction terminal box) to which the ORP Sensor cable is connected has already been installed.

2.2 Requirements for mounting the ORP Sensor

2.2.1 In case of installing the PH8HG Guide-pipe Holder

To install the sensor in the guide pipe, proceed as follows:

- (1) Connect the sensor cable to the associated instrument correctly by referring to Section 2.3 provided later.
- (2) Mount the liquid junction in the sensor body. Peel off the seal attached to the liquid junction mounting hole in the sensor body. Screw the liquid junction gently two or three turns into the hole.
- (3) If specified, a reserve tank containing 250 mL KCl solution and mounting hardware to hold this tank are supplied with the OR8EFG ORP Sensor. Attach the holding hardware to the pipe (2-inch). Connect the reserve tank to the KCl solution supply tube of the sensor. Remove the cap from the tank and screw the tube connector securely into the tank.
- (4) Supply KCl solution to the sensor (see Figure 2.3). First, mount the reserve tank on the mounting hardware with the tube connection part directed downwards. Using the pin supplied with the tank, make several holes at its top (see Figure 2.3). Stand the sensor upside down at a lower position than the reserve tank as shown in Figure 2.3 so that KCl solution flows from the tank into the sensor. When the KCl solution fills the sensor and overflows from the liquid junction mounting hole, securely screw the liquid junction into the mounting hole.

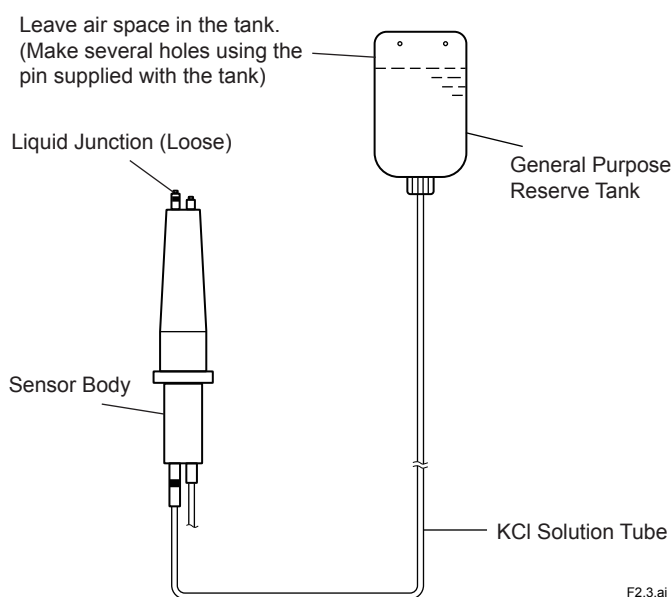

Figure 2.3 Supplying KCl Solution to Sensor Body

- (5) Attach the "stopper" supplied with the guide pipe to the sensor cable.
Fix the sensor cable so that the sensor tip projects 20 to 30 mm out from the pipe end when the ORP Sensor is suspended in the guide pipe as shown in Figure 2.4.

NOTE

If the sensor tip does not project out from the pipe end, the measured value may not respond promptly to the ORP variations of the measured solution. This may cause problems for ORP measurement and control. On the other hand, if the sensor tip projects too far from the pipe end, the force on the sensor may damage the sensor cable from scraping it against the pipe.

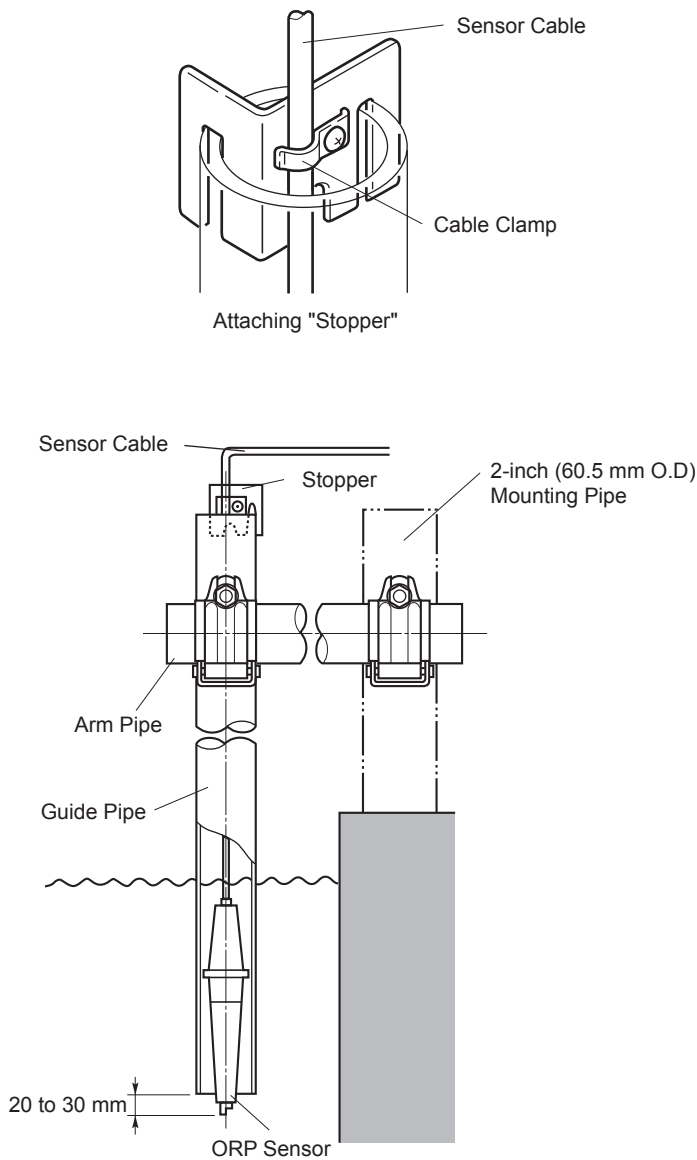

Figure 2.4 Mounting Sensor in Guide Pipe

2.2.2 Installing Sensor in PH8HS Submersion Holder

To install the sensor in the submersion holder, proceed as follows:

- (1) Pass the sensor cable through the sensor holder. If the submersion holder remains installed, remove the sensor holder in any case.

For a pipe-mounting submersion holder without a cleaner, loosen the sensor holder nut to remove the holder.

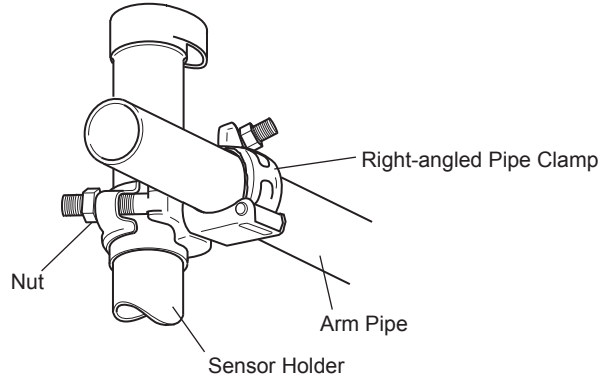

Removal of Sensor Holder (Arm Pipe used with option /MS1 or /MS2)

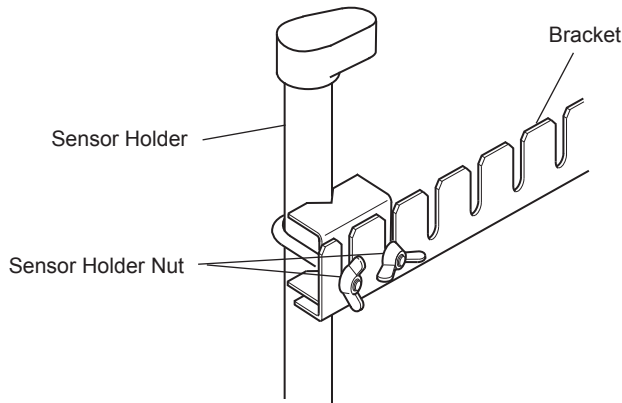

F2.5.ai

Removal of Sensor Holder (Stainless Bracket used with option /MS3 or /MS4)

Figure 2.5 Removal of Sensor Holder (for Pipe Mounting Sensor without Cleaner)

For a flange mounting submersion holder without a cleaner, remove the sensor holder by loosening the two bolts securing the sensor holder to the flange (see Figure 2.6).

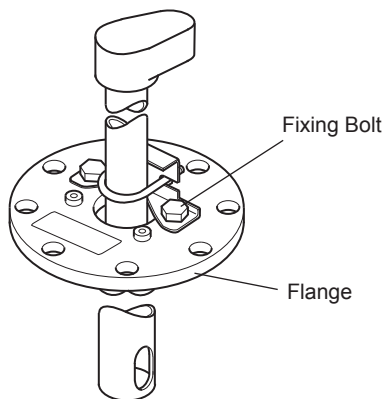

F2.6.ai

Figure 2.6 Removal of Sensor Holder (for Flange Mounting Sensor without Cleaners)

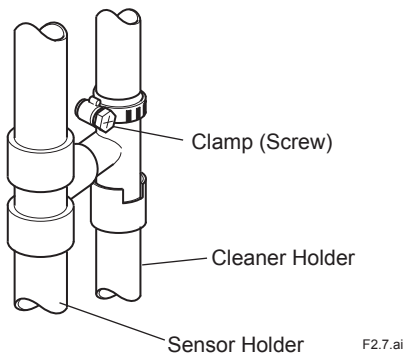

Figure 2.7 Removal of Sensor Holder (with Cleaner)

To install the sensor cable in the sensor holder, first remove the protector screwed onto the sensor holder end and then remove the protective foam piece (for shipping; thus, it is not necessary after the sensor is installed in the holder). Pass the sensor cable through the O-ring then attach the O-ring to the sensor flange (see Figure 2.7).

When passing the sensor cable through the holder, if the inside of the holder is dirty or wet, take special care to keep the cable dry by covering the sensor cable end with a polyethylene bag or the like.

For details to install the sensor onto a holder, refer to relevant IMs.

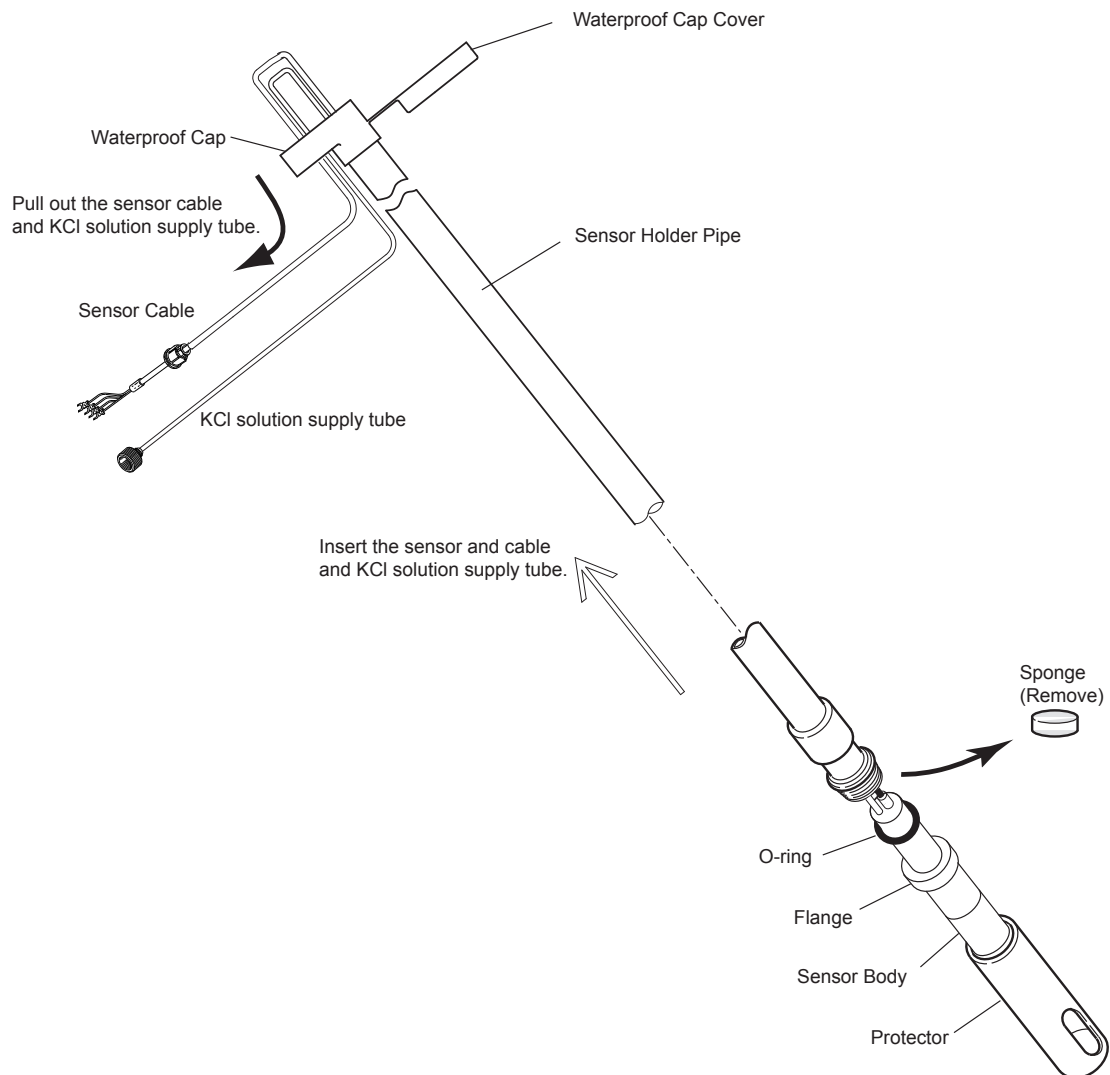

Figure 2.8 Installing the Sensor Cable

- (2) Connect the sensor cable to the associated instrument correctly by referring to Section 2.3.
- (3) Mount the liquid junction in the sensor body. Peel off the seal attached to the liquid junction mounting hole on the sensor body. Screw the liquid junction gently two or three turns into the hole.
- (4) If specified, a reserve tank containing 250 mL KCl solution and mounting hardware to hold this tank are supplied with the OR8EFG ORP Sensor. Attach the mounting hardware to the pipe (2-inch). Connect the reserve tank to the KCl solution supply tube of the sensor. Remove the cap from the tank and screw the tube connector securely into the tank.
- (5) Supply KCl solution to the sensor. First, mount the reserve tank on the mounting hardware with the tube connection part directed downwards. Using the pin supplied with the tank make several holes in its top (see Figure 2.3). Stand the sensor upside down at a position lower than the reserve tank as shown in Figure 2.3 so that KCl solution flows from the tank into the sensor. When the KCl solution fills the sensor and overflows from the liquid junction mounting hole, securely screw the liquid junction into the mounting hole.
- (6) Screw the protector to fix the sensor to the holder. In this case, remove the protective cap and secure the protector so that the flange of the sensor compresses the O-ring firmly about the installation method.

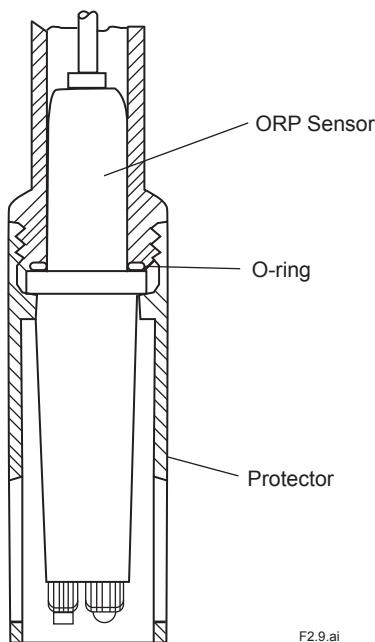

Figure 2.9 Installing Sensor in Submersion Holder

- (7) Close the waterproof cap, and attach the holder to the arm pipe, flange or cleaner holder completely.

2.2.3 Installing Sensor in Flow-through Holder

To install the sensor in a flow-through holder, proceed as follows:

- (1) Connect the sensor cable to the associated instrument. First, remove the sensor fixing nut and pass the sensor cable through the nut.

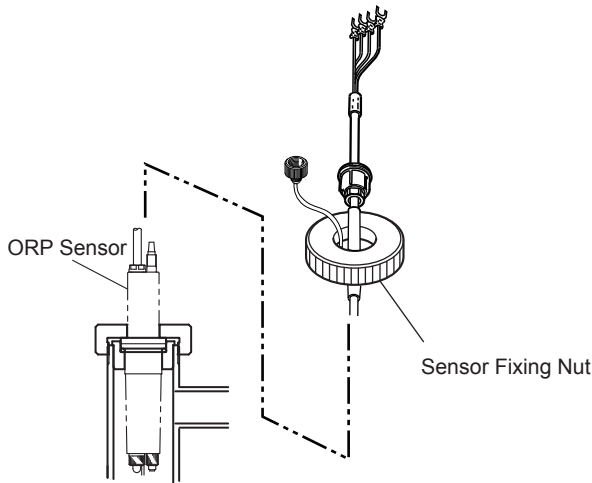

Figure 2.10 Preparation for Sensor Cable Connection

Properly connect the sensor cable by referring to Section 2.3.

- (2) Mount the liquid junction on the sensor body. Peel off the seal covering the liquid junction mounting hole in the sensor body. Screw the liquid junction softly into the hole by turning it for two or three turns.
- (3) If specified, a reserve tank containing 250 mL solution and mounting hardware to hold this tank, or a medium pressure reserve tank are supplied with the OR8EFG ORP Sensor.

Attach the mounting hardware for general purpose reserve tank to a pipe (2-inch). Connect the general purpose reserve tank to the KCl solution supply tube of the sensor. Remove the cap from the tank and screw the tube connector securely into the tank.

When using a medium pressure reserve tank, attach it to a pipe (2-inch) and perform air piping to supply pressure for reserve tank as shown in Figure 2.11. Connect the KCl supply tube of the sensor to this reserve tank.

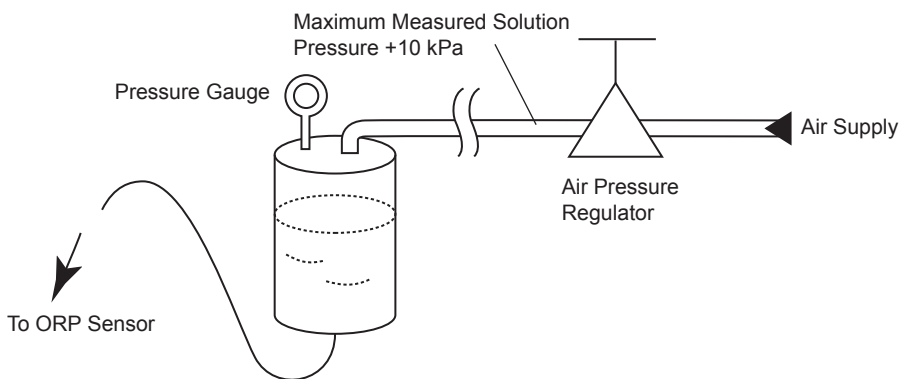

Figure 2.11 Air Piping for Pressurizing Medium Pressure Reserve Tank

- (4) Supply KCl solution to the sensor.

- **When a general purpose reserve tank is used.**

First, mount the reserve tank on the holding hardware with the tube connection part directed downwards. Using the pin supplied with the tank, make several holes in its top (see Figure 2.3). Stand the sensor upside down at a position lower than the reserve tank as shown in Figure 2.3 so that KCl solution flows from the tank into the sensor. When the KCl solution fills the sensor and overflows from the liquid junction mounting hole, securely screw the liquid junction into the mounting hole.

- **When a reserve tank for medium pressure is used.**

First, fill the reserve tank with KCl solution (*1). Loosen the nut on the reserve tank upside and remove the cap — the pressure gauge is mounted — and pour about 250 mL of KCl solution into the tank. Stand the sensor upside down at a position lower than the reserve tank so that solution flows from the tank into the sensor. When the KCl solution fills the sensor and overflows from the liquid junction mounting hole, securely screw the liquid junction into the mounting hole. Remount the cap of the reserve tank. Tighten the nut securely.

*1: Use 3.3 mol/L KCl solution. If KCl powder (ordered separately) are supplied with the PH8AX accessories, dissolve one bag (60 g) of KCl powder in pure water to make exactly 250 mL of solution.

- (5) Connect the ORP Sensor to its holder. Remove the protective cap from the sensor. Also remove the protective foam piece (for shipping - this is not necessary after installing the sensor) from the holder. Be sure that the liquid junction and indicator electrode are mounted properly. Insert the sensor tip into the holder and tighten the sensor fixing nut securely (see Figure 2.10).

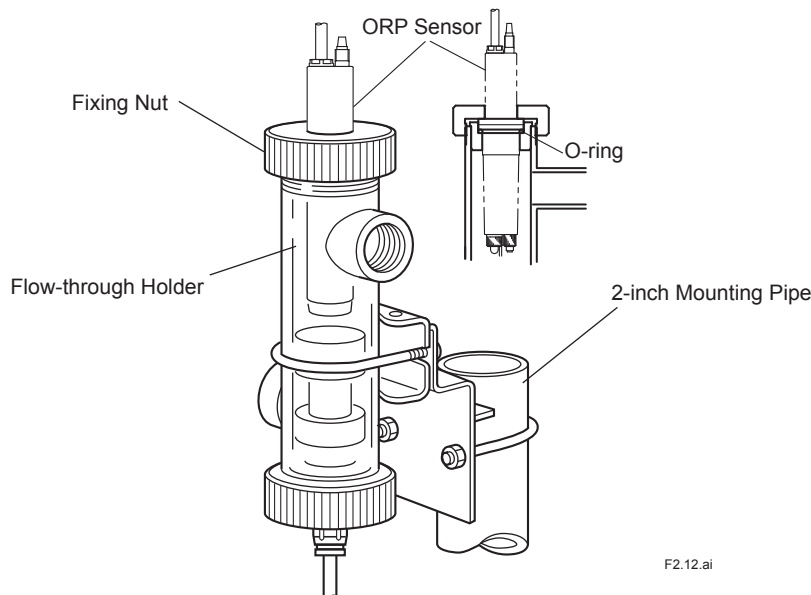

F2.12.ai

Figure 2.12 **Installing Sensor in Flow-through Holder**

2.3 ORP Sensor Cable Wiring Procedure

2.3.1 Processing of Cable Inlet Hole

Open the cable inlet hole in terminal box using the supplied punch tool. The location of the cable inlet hole is shown by the circle-shaped groove under the case. The end of the supplied punch tool is put in the center of this circle and it is tapped with appropriate force. You can punch out the hole along the groove.

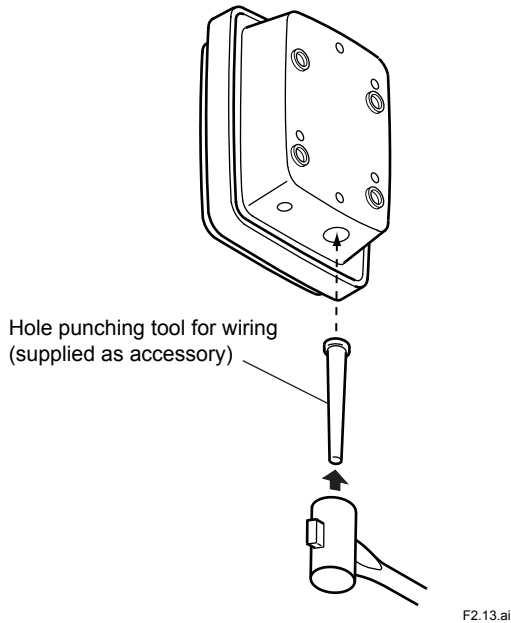

Figure 2.13 How to punch out the wiring hole

2.3.2 Connecting Sensor Cable

- (1) Loosen two screws which are at front of terminal box and detach the cover.
- (2) After detaching the nut from the cable gland of sensor cable, pull the cable into the terminal box from sensor cable inlet hole.
- (3) Connect the sensor cable to the terminals.

After passing the cable through the nut, check the symbol on each core wire, then connect each core wire to the corresponding terminal.

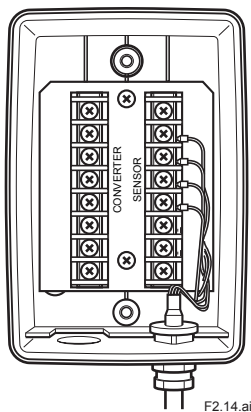

Figure 2.14 Connecting Sensor Cable (In case of the OR8TBG)

- (4) Mount the cable gland in the cable inlet hole.

Put the nut in place, and screw it onto the main body sufficiently. At this time, loosen the cap so that the cable is not twisted. After fixing the main body, tighten the cap to keep moisture out of the equipment. However if the cap is screwed up too tight, the cable will be damaged.

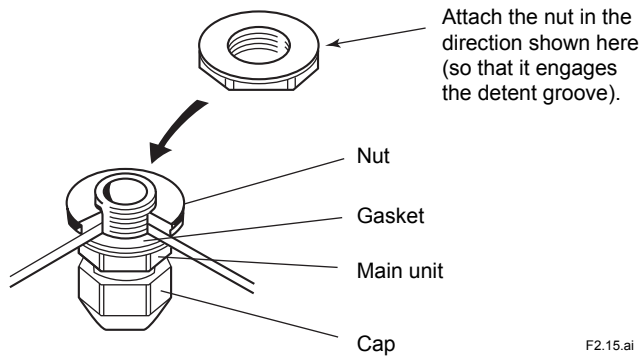

Figure 2.15 Cable Gland

F2.15.ai

- (5) After completing the cable connections, replace the box cover securely, thus preventing moisture from getting into the case.

2.3.3 Connecting Sensor Cable to Two-wire ORP Transmitter

To connect the sensor cable to the two-wire ORP Transmitter, proceed as follows:

- (1) Loosen the four screws that tighten the transmitter cover. Then remove the transmitter cover.
- (2) Connect the sensor cables to the relevant terminals of the transmitter:

First, remove the nut from the cable gland. Insert the cable into the right opening for the wiring. Then pass the cable through the nut, Connect the individual cable conductors to the relevant terminals correctly by referring to the markings on the individual conductors.

For details, refer to relevant IMs.

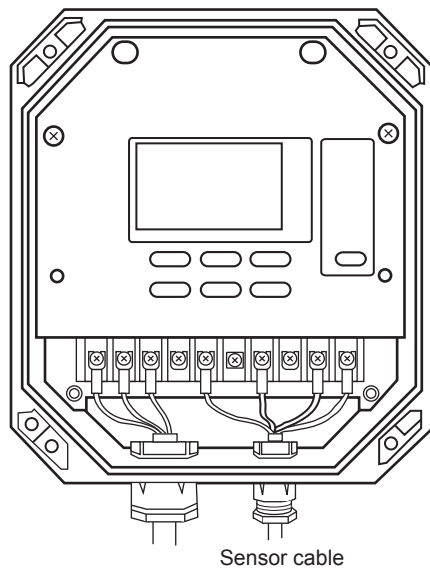

Figure 2.16 Connecting Sensor Cable to Two-wire ORP Transmitter

- (3) Install the cable gland in the wiring hole as follows:
Pass the tip of the cable gland into the opening and completely tighten the gland with the nut inside the case. After tightening the gland, secure the cap properly to prevent moisture from getting into the case.
Caution: Do not overly tighten the cap. Otherwise, the cable may be damaged.
- (4) After completing the cable connections, replace the transmitter cover securely, thus preventing moisture from getting into the case.

2.3.4 Connecting Sensor Cable to Four-wire ORP Converter

To connect the sensor cable to a Four-wire ORP Converter, proceed as follows:

- (1) Loosen the four screws that tighten the converter cover. Then open the converter cover.
- (2) Connect the sensor cables to the relevant terminals of the converter:

First, remove the nut from the cable gland. Insert the cable into the right opening for the wiring. Then pass the cable through the nut, Connect the individual cable conductors to the relevant terminals correctly by referring to the markings on the individual conductors.

For details, refer to relevant IMs.

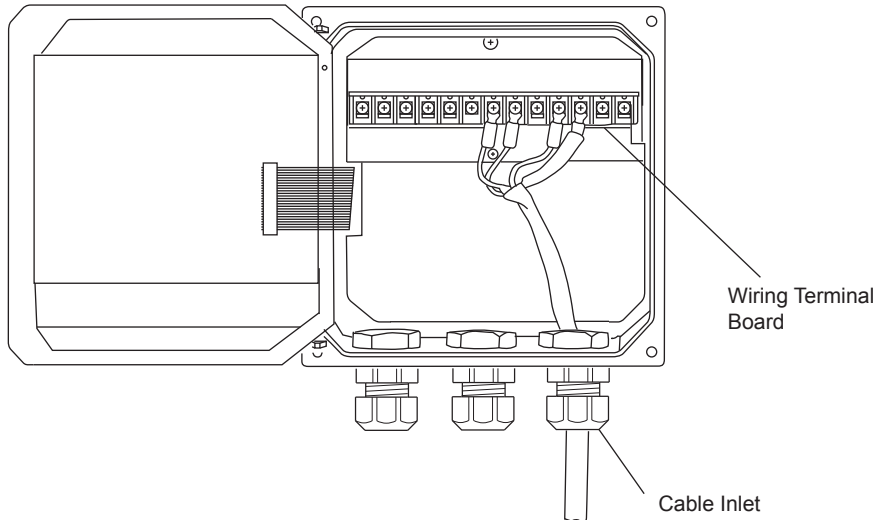

Figure 2.17 Connecting Sensor Cable to Four-wire ORP Converter

- (3) Install the cable gland in the wiring hole as follows:

Pass the tip of the cable gland into the opening and completely tighten the gland with the nut inside the case.

After tightening the gland, secure the cap properly to prevent moisture from getting into the case.

Caution: Do not overly tighten the cap. Otherwise, the cable may be damaged.

- (4) After completing the cable connections, close the converter cover securely, thus preventing moisture from getting into the case.

3. Maintenance on operation

3.1 Operation and Periodic Maintenance

3.1.1 Calibrating ORP Sensor Using Checking Solutions

Dirt attached to the liquid junction or sensitive parts (platinum electrodes) may have an adverse effect on electromotive force and response characteristics, so ORP sensors require periodic cleaning for good operating conditions. ORP sensors should be checked and calibrated if the following conditions are met.

(1) Sensor checks

- If a new ORP sensor is used or the existing sensor has been unused for an extended period of time.
- When an ORP sensor sensitive part (platinum electrode) or a liquid junction is cleaned.

(2) Calibration

- If sensor electromotive force is outside the allowable ranges.
- If the measured value by the ORP sensor is adjusted to the measured value by other sensors.

For more detailed information on the calibration procedures, see the separate Instruction Manuals "Two-wire Liquid Analyzer" (publication no. IM 12A01A02-01E) and "Four-wire pH/ORP Converter" (publication no. IM 12B07C05-01E).

3.1.2 Pressurizing Reserve Tank

When the ORP Sensor with medium pressure reserve tank is used, apply air pressure to the reserve tank before flowing the measured solution through the holder. Set the air pressure a little higher than the maximum pressure of the measured solution during the operation.

The flow rate of the KCl solution from the liquid junction is 3 mL/day or less (20 mL/day or less when PTFE junction is used) when the pressure difference between air and measured solution is 10 kPa and the flow rate increases in proportion to the pressure difference. Therefore, it is important to minimize the consumption of the KCl solution by minimizing the pressure variation of the measured solution and making sure that the air pressure is not set too high.

3.1.3 Replenishment of KCl Solution

When the KCl solution in the tank seems to be nearly exhausted while using a ORP Sensor with general type reserve tank, replace the reserve tank with new one (provided separately as spare part). Instead of tank replacement, when a KCl solution prepared using KCl powder is used for replenishment, use 3.3 mol/L solution by dissolving 246 g of KCl powder in pure water to make exactly one liter of solution. When pouring the solution into the tank, be careful that KCl solution does not overflow from the vent holes of the tank.

When a ORP Sensor with a medium pressure reserve tank is used, replenish the KCl solution when the KCl solution in the tank seems to be nearly exhausted. Carry out replenishment of KCl solution as follows:

- (1) Close the valves to shut off the (low of measured solution (see Figure 3.1) - first in the inlet then the outlet valves in the flow-through type holder.

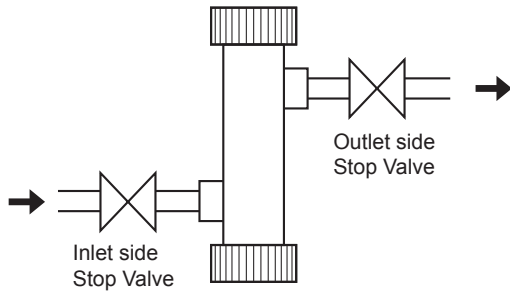

Figure 3.1 Process Piping of Flow-through Type Holder.

- (2) Remove the socket connector on the reserve tank and stop the air pressurizing the tank (see Figure 3.2).

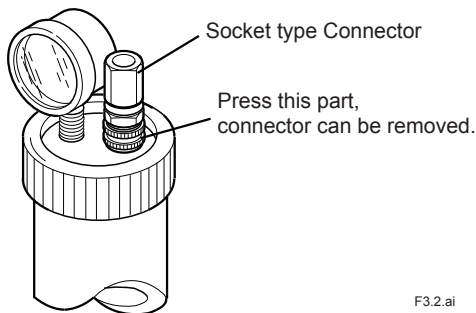

Figure 3.2 Socket Type Connector.

- (3) Remove the nut fixing the reserve tank cap and remove the cap.
- (4) Refill the tank with 3.3 mol/L KCl solution (see Figure 3.3). The maximum solution level 30 to 40 mm lower than the top.

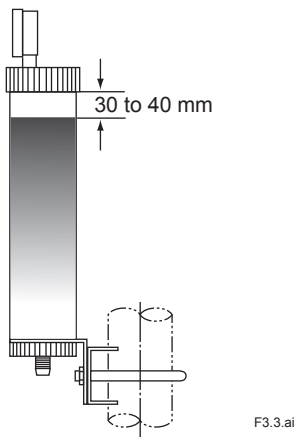

Figure 3.3 Maximum KCl Replenishment Level

- (5) Retighten the nut to fix the cap in position.
- (6) Open the valve and let the measured solution flow through the holder.

3.1.4 Cleaning Indicator Electrode and Liquid Junction

Staining of a indicator electrode or liquid junction can cause measurement errors. Therefore, if the measured solutions tend to stain the electrode, the indicator electrode and liquid junction must be cleaned periodically - depending on the degree of staining. If the ORP Sensor is installed in a holder with a cleaner, the sensor is continuously (for an ultrasonic cleaner) or intermittently (for a jet or brush cleaner) cleaned automatically.

Because of this, sensor cleaning is not usually required. However, if the sensor characteristics are affected by chemical staining, for example, when the sensor is used for ORP measurement of a highly alkaline solution, carry out acid washing.

To clean the indicator electrode or liquid junction, proceed as follows:

- **Stains due to suspended Solids, Sticky Materials, Microbes or the like**

Using soft tissue paper, wipe the stains off the indicator electrode or liquid junction. In addition, clean off remaining stains by rinsing with water.

- **Stains due to Oily Materials**

Wash off stains by submerging in a neutral detergent solution in a beaker, etc, (for from several tens of minutes to several hours depending on the degree of staining).

- **Chemical Stains such as due to Metallic Adsorption**

Place the indicator electrode or liquid junction in a diluted hydrochloric acid solution (1 to 2%) for several minutes (acid washing).

3.2 Replacing Consumable Parts

3.2.1 Replacing Liquid Junction

Even after washing the liquid junction, if normal measurement cannot be made, replace the liquid junction.

When replacing the liquid junction, fill the sensor with KCl solution to just before the solution overflows through the liquid junction mounting hole. Use a 3.3 mol KCl solution (a higher concentration of KCl or KCl powder) for this application.

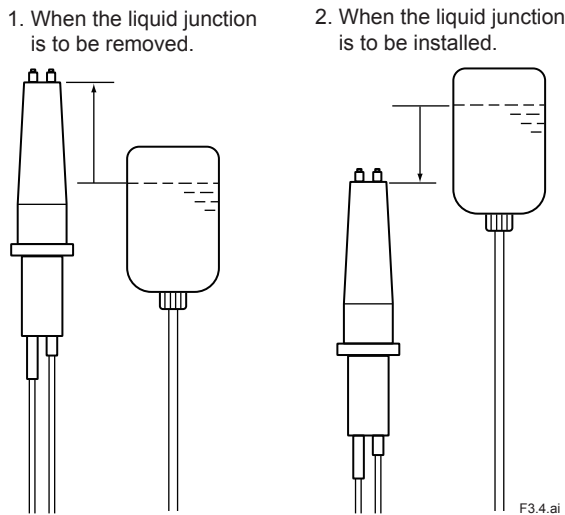

Figure 3.4 Replacing Liquid Junction

3.2.2 Replacing O-rings for Indicator Electrode

As the inside of the indicator electrode mounting hole must have high insulation resistance, fluorocarbon rubber O-rings - with superior chemical and heat resistance - are used for sealing. Except for special uses, this O-ring does not need individual replacement. If any damage - which might cause problems - is detected in the O-ring, as a rule, replace it along with the indicator electrode. Although the O-ring can be replaced individually if the O-ring deteriorates much faster than the indicator electrode, it is recommended that the whole indicator electrode be replaced to avoid possible deterioration of the O-ring inside the indicator electrode. For individual replacement of the O-ring, use the one recommended by Yokogawa.

When installing the O-ring, wind a slip of paper or tape around the thread part on the indicator electrode so as not to scratch the O-ring. Otherwise, such scratches may damage its sealing properties.

For ordering, refer to the Customer Maintenance Parts List (CMPL) at the end of the book to check the appropriate part number of the O-ring.

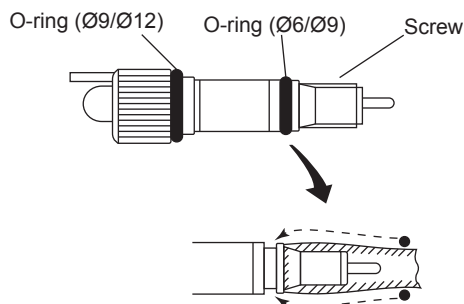

Before installing, wind a slip of paper or tape around the thread part to prevent scratches.

Figure 3.5 Installing the O-ring

Customer Maintenance Parts List

Model OR8EFG KCI Filling type ORP Sensor

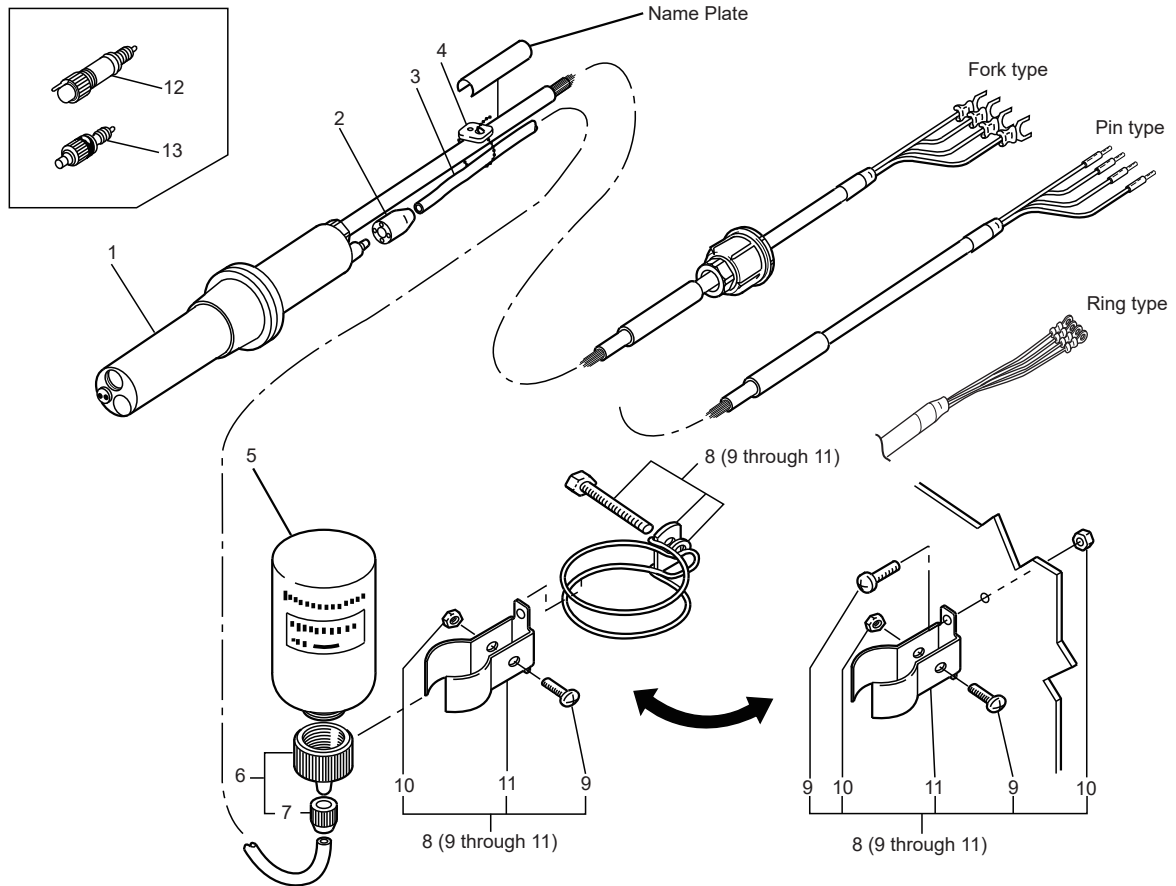

Item	Part No.	Qty	Description	Item	Part No.	Qty	Description
1	Below —	1	Body Assembly see GS 12B07B02(E)	5	K9084KQ	1	Bottle (for general use)
2	K9142EJ	1	Cap	6	K9084KV	1	Connector Assembly (for general use)
3	Below	1	KCI Filling Tube	7	K9084CG	1	Nut
	K9142PF		Length 3 m	8	K9142VE	1	Holder Assembly
	K9142PG		Length 5 m	9	—	3	B.H. Screw, M4X18
	K9142NH		Length 7 m	10	—	3	Nut
	K9142NJ		Length 10 m	11	—	1	Bracket
	K9142NK		Length 15 m	12	Below	1	ORP Electrode Assembly
	K9142NL		Length 20 m		K9142TS		Pt
	(L9901MB)		(Length by meter, max.100 m)		K9142TT		Au
	K9142PJ		Length 3 m		K9142QR	1	O-Ring, 6 mm ID. X 9 mm OD.
	K9142PK		Length 5 m		K9142QS	1	O-Ring, 9 mm ID. X 12 mm OD.
	K9142NM		Length 7 m	13	Below	1	Junction Assembly
	K9142NN		Length 10 m		K9142TH		for general use
	K9142NP		Length 15 m		K9142HW		for OR8EFG/TF PTFE junction
	K9142NQ		Length 20 m		K9142UH		for OR8EFG/CJ Ceramic junction
	(L9901CA)		(Length by meter, max.100 m)				
4	L9813UG	3 or 5	Clamp		K9142QR	1	O-Ring, 6 mm ID. X 9 mm OD.

Medium Pressure Type

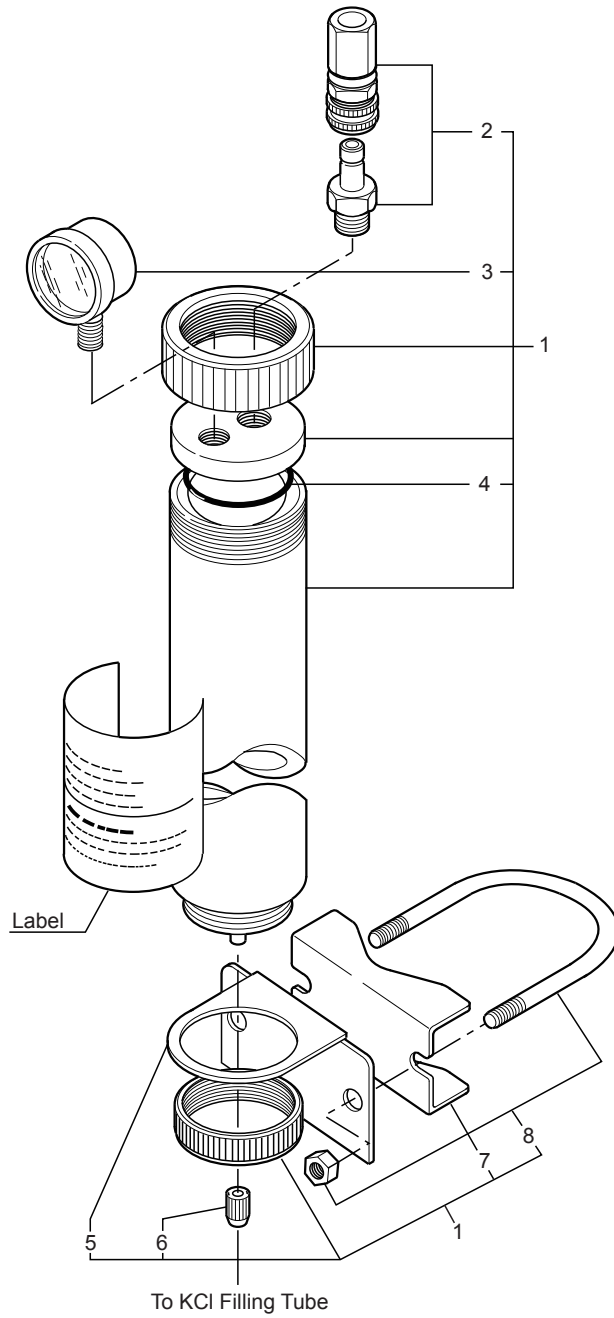

Item	Part No.	Qty	Description
1	K9142VG	1	Tank Assembly (item 2 through 8)
2	L9835DD	1	Joint
3	L9867BS	1	Pressure Gauge (Range:0 to 700 kPa)
4	G9303AE	1	O-Ring
5	K9142VP	1	Bracket
6	K9142EJ	1	Cap
7	L9826AL	1	Bracket
8	D0117XL-A	1	U-Bolt Assembly

Revision Information

- Title : Model OR8EFG KCl Filling type ORP Sensor
- Manual No. : IM 12C07J01-01E

Apr. 2020/8th Edition

Revised along with an additional code for option /TF (P.1-2, 1-3, 1-4. 3-1)
CMPL 12C03J01-01E was revised to 9th edition (a part addition: Junction for /TF)

Feb. 2020/7th Edition

Added a terminal connection to -E: FLXA402 to Pin terminal (P. 1-2)

Nov. 2018/6th Edition

Added FLXA402
P i, P1-3.

Oct. 2015/5th Edition

Added FLXA202
P i, P1-3.
Unification of the material name
P1-1, P1-2.

CMPL 12C03J01-01E was revised to 8th edition

Jun. 2013/4th Edition

P 1-4, Some revision of consumables; P 3-1, Some revision of pressurizing reserve tank; etc.

Sep. 2011/3rd Edition Page layout changed by InDesign

P.i, Reference manual number of FLXA21 added; P.v, Some of contents corrected; P.1-3, M4 ring terminals for FLXA21 added to MS-code; P.1-5, M4 ring terminals added to external dimensions; P.2-13, Section no. corrected (2.3.3--->2.3.4);
CMPL 12C03J01-01E was revised to 7th edition (P/N of KCl tube modified).

Apr. 2008/2nd Edition

M3 ring terminals added for PH450G, CMPL12C03J01-01E revised to 5th edition.

Sep. 2006/1st Edition

Newly published.

-
- For more information about Yokogawa products:
<http://www.yokogawa.com/an>
-

