

Model IR400 Infrared Gas Analyzer

IM 11G02N01-01E

◆ PREFACE

We are grateful for your purchase of Yokogawa's Infrared Gas Analyzer, Model: IR400. Read this instruction manual carefully.

The related documents are as follows.

General Specifications: GS 11G02N01-01E

User's Manual:	IM 11G02N01-01E	(this manual)
	IM 11G02P01-01E	Communication Functions (MODBUS)
	IM 11G00E01-01EN	ZX8D Zirconia Oxygen Analyzer
	IM 11G00E02-01EN	K9350LE NO ₂ /NO Converter
	IM 11G00E02-02EN	K9350LF NO ₂ /NO Converter

The "E" or "EN" in the document number is the language code, meaning English

An exclusive User's Manual might be attached to the products whose suffix codes or option codes contain the code "Z" (made to customers' specifications). Please read it along with this manual.

WARNING

This unit is not explosion-proof type. Do not use it in a place with explosive gases to prevent explosion, fire or other serious accidents.

CAUTION

- For installation, observe the rule on it given in the instruction manual and select a place where the weight of gas analyzer can be endured. Installation at an unsuited place may cause turnover or fall and there is a risk of injury.
- During installation work, care should be taken to keep the unit free from cable chips or other foreign objects. Otherwise, it may cause fire, trouble or malfunction of the unit.

WARNING

In piping, the following precautions should be observed. Wrong piping may cause gas leakage. If the leaking gas contains a toxic component, there is a risk of serious accident being induced. Also, if combustible gas is contained, there is a danger of explosion, fire or the like occurring.

- Connect pipes correctly referring to the instruction manual.
- Exhaust should be led outdoors so that it will not remain in the locker and installation room. Exhaust from the analyzer should be relieved in the atmospheric air in order that an unnecessary pressure will not be applied to the analyzer. Otherwise, any pipe in the analyzer may be disconnected to cause gas leakage.
- For piping, use a pipe and a pressure reducing valve to which oil and grease are not adhering. If such a material is adhering, a fire or the like accident may be caused.

 **CAUTION**

- Wiring work must be performed with the main power set to OFF to prevent electric shocks.
 - Enforce construction of class-D grounding wire by all means. If the specified grounding construction is neglected, a shock hazard or fault may be caused.
 - Wires should be the proper one meeting the ratings of this instrument. If using a wire which cannot endure the ratings, a fire may occur.
 - Be sure to use a power supply of correct rating. Connection of power supply of incorrect rating may cause fire.
-

 **WARNING**

- Do not smoke nor use a flame near the gas analyzer. Other wise, a fire may be caused.
 - Do not allow water to go into the gas analyzer. Otherwise, hazard shock or fire in the instrument may be caused.
-

 **WARNING**

Purge not only inside of IR400 but all measuring gas lines with zero gas sufficiently, when you provide maintenance or inspection on IR400 with its cover or door open. Otherwise it may cause hazardous accidents such as gas leakage, fire and explosion.

 **CAUTION**

Do not operate the analyzer for a long time with its cover or door left open. Otherwise, dust, foreign matter, etc. may stick on internal walls, thereby causing faults.

 **CAUTION**

- Be sure to observe the following for safe operation avoiding the shock hazard and injury.
 - Replacement parts such as a maintenance part should be disposed of as incombustibles. For details, follow the local ordinance.
-

- **Inspection of product**

On receipt of the product, inspect the package and note it has no damage caused by the delivery.

Confirm the specification of the product conforms with your order and accessories are all delivered. Check the product code label on a model plate is correct.

◆ Safety Precautions

■ Safety, Protection, and Modification of the Product

- This manual is intended for the following personnel :
 - Engineers responsible for installation, wiring, and maintenance of the equipment
 - Personnel responsible for normal daily operation of the equipment.
- In order to protect the system controlled by the product and the product itself and ensure safe operation, observe the safety precautions described in this user's manual. We assume no liability for safety if users fail to observe these instructions when operating the product.
- If this instrument is used in a manner not specified in this user's manual, the protection provided by this instrument may be impaired.
- If any protection or safety circuit is required for the system controlled by the product or for the product itself, prepare it separately.
- Be sure to use the spare parts approved by Yokogawa Electric Corporation (hereafter simply referred to as YOKOGAWA) when replacing parts or consumables.
- Modification of the product is strictly prohibited.
- The following safety symbols are used on the product as well as in this manual.



WARNING

This symbol indicates that an operator must follow the instructions laid out in this manual in order to avoid the risks for the human body and health including risk of injury, electric shock, or fatalities. or the damages to instruments. The manual describes what special care the operator must take to avoid such risks.



CAUTION

This symbol indicates that the operator must refer to the instructions in this manual in order to prevent the instrument (hardware) or software from being damaged, or a system failure from occurring.

The following are signal words to be found only in our instruction manuals.

CAUTION

This symbol gives information essential for understanding the operations and functions.

NOTE

This symbol indicates information that complements the present topic.

■ Notes on Handling User's Manuals

- Please hand over the user's manuals to your end users so that they can keep the user's manuals on hand for convenient reference.
- Please read the information thoroughly before using the product.
- The purpose of these user's manuals is not to warrant that the product is well suited to any particular purpose but rather to describe the functional details of the product.
- No part of the user's manuals may be transferred or reproduced without prior written consent from YOKOGAWA.
- YOKOGAWA reserves the right to make improvements in the user's manuals and product at any time, without notice or obligation.
- If you have any questions, or you find mistakes or omissions in the user's manuals, please contact our sales representative or your local distributor.
- This manual is an essential part of the product ; keep it in a safe place for future reference.

■ Drawing Conventions

Some drawings may be partially emphasized, simplified, or omitted, for the convenience of description.

Some screen images depicted in the user's manual may have different display positions or character types (e.g., the upper / lower case). Also note that some of the images contained in this user's manual are display examples.

■ Authorized Representative in EEA

The Authorized Representative for this product in EEA is Yokogawa Europe B.V. (Euroweg 2, 3825 HD Amersfoort, The Netherlands).

■ Trademark Acknowledgments

- All other company and product names mentioned in this user's manual are trademarks or registered trademarks of their respective companies.
- We do not use TM or ® mark to indicate those trademarks or registered trademarks in this user's manual

■ Notes on Use in Korea

The AC cord with the following products is not compliant with the safety standards in Korea.

Please do not use it to connect household appliances in Korea.

It is prohibited to use an adapter connector to change the plug shape for the AC cord of the following products.

- IR400-□□□□□□□□□□□□-□□J/□
- IR400-□□□□□□□□□□□□-□□E/□

◆ CE marking products

■ Authorized Representative in EEA

The Authorized Representative for this product in EEA is Yokogawa Europe B.V. (Euroweg 2, 3825 HD Amersfoort, The Netherlands).

■ Identification Tag

This manual and the identification tag attached on packing box are essential parts of the product. Keep them together in a safe place for future reference.

■ Users

This product is designed to be used by a person with specialized knowledge.

■ How to dispose the batteries

This is an explanation about the new EU Battery Directive. This directive is only valid in the EU.

Batteries are included in this product. Batteries incorporated into this product cannot be removed by yourself. Dispose them together with this product.

When you dispose this product in the EU, contact your local Yokogawa Europe B.V.office.

Do not dispose them as domestic household waste.

Battery type: Manganese dioxide lithium battery



Notice:

The symbol (see above) means they shall be sorted out and collected as ordained in ANNEX II in DIRECTIVE 2006/66

■ Information of the WEEE Directive

This product is purposely designed to be used in a large scale fixed installations only and, therefore, is out of scope of the WEEE Directive. The WEEE Directive does not apply. This product should be disposed in accordance with local and national legislation/regulations.

The WEEE Directive is only valid in the EU.

◆ After-Sales Warranty

- **Do not modify the product.**
- **Yokogawa warrants the product for the period stated in the pre-purchase quotation. Yokogawa shall conduct defined warranty service based on its standard. When the customer site is located outside of the service area, a fee for dispatching the maintenance engineer will be charged to the customer.**
- **During the warranty period, for repair under warranty carry or send the product to the local sales representative or service office. Yokogawa will replace or repair any damaged parts and return the product to you.**
 - Before returning a product for repair under warranty, provide us with the model name and serial number and a description of the problem. Any diagrams or data explaining the problem would also be appreciated.
 - If we replace the product with a new one, we won't provide you with a repair report.
- **In the following cases, customer will be charged repair fee regardless of warranty period.**
 - Failure of components which are out of scope of warranty stated in instruction manual.
 - Failure caused by usage of software, hardware or auxiliary equipment, which Yokogawa did not supply.
 - Failure due to improper or insufficient maintenance by user.
 - Failure due to misoperation, misuse or modification which Yokogawa does not authorize.
 - Failure due to power supply (voltage, frequency) being outside specifications or abnormal.
 - Failure caused by any usage out of scope of recommended usage
 - Any damage from fire, earthquake, a storm and flood, lightning, disturbance, riot, warfare, radiation and other natural changes.
- **Yokogawa does not warrant conformance with the specific application at the user site. Yokogawa will not bear direct/indirect responsibility for damage due to a specific application.**
- **Yokogawa will not bear responsibility when the user configures the product into systems or resells the product.**
- **Maintenance service and supplying repair parts will be covered for five years after the production ends. For repair this product, please contact the nearest sales office described in this instruction manual.**

Model IR400 Infrared Gas Analyzer

IM 11G02N01-01E 9th Edition

CONTENTS

- ◆ PREFACE.....i
- ◆ Safety Precautionsiii
- ◆ CE marking productsv
- ◆ After-Sales Warrantyvi
- 1. OVERVIEW 1-1
 - 1.1 Name and description of main unit..... 1-2
 - 1.2 Input/Output terminal module 1-3
- 2. SPECIFICATIONS 2-1
 - 2.1 Standard Specifications..... 2-1
 - 2.2 Model and Suffix codes 2-6
 - 2.3 External Dimensions 2-13
- 3. INSTALLATION 3-1
 - 3.1 Installation conditions 3-1
 - 3.2 Installation 3-2
 - 3.2.1 Installation of analyzer main frame 3-2
 - 3.2.2 Mounting input/output terminal module 3-3
 - 3.3 Piping 3-4
 - 3.4 Sampling 3-7
 - 3.4.1 Conditions of sampling gas..... 3-7
 - 3.4.2 Sampling gas flow..... 3-7
 - 3.4.3 Preparation of standard gas 3-7
 - 3.4.4 Reduction of moisture interference..... 3-7
 - 3.4.5 Purging of instrument inside 3-8
 - 3.4.6 Pressure at sampling gas outlet 3-8
 - 3.4.7 Example configuration of gas sampling system 3-9
 - 3.5 Wiring 3-10
 - 3.5.1 Power inlet 3-10
 - 3.5.2 Input/Output terminal module 3-10
- 4. OPERATION 4-1
 - 4.1 Warm-up operation and regular operation..... 4-1
 - 4.2 Name and description of operation panel..... 4-2
 - 4.3 Overview of display and operation panels..... 4-3
 - 4.4 Outline of display screen 4-4

4.5	General operation	4-7
5.	SETTING AND CALIBRATION	5-1
5.1	Switch of range	5-1
5.1.1	Setting of range switch mode.....	5-1
5.1.2	Manual range switch	5-2
5.2	Calibration setting	5-3
5.2.1	Setting of calibration concentration.....	5-3
5.2.2	Setting of manual zero calibration	5-5
5.2.3	Setting of calibration range	5-7
5.2.4	Setting of auto calibration component/range.....	5-9
5.3	Alarm setting	5-11
5.3.1	Setting of alarm values	5-11
5.3.2	Hysteresis setting.....	5-13
5.4	Setting of auto calibration	5-14
5.4.1	Auto calibration	5-14
5.4.2	Forced run/stop of auto calibration	5-17
5.5	Setting of auto zero calibration	5-20
5.5.1	Auto zero calibration	5-20
5.5.2	Forced run/stop of auto zero calibration	5-22
5.6	Peak alarm setting	5-25
5.7	Parameter setting	5-27
5.8	Maintenance mode	5-34
5.9	Calibration	5-40
5.9.1	Zero calibration	5-40
5.9.2	Span calibration	5-41
6.	MAINTENANCE	6-1
6.1	Daily check	6-1
6.2	Daily check and maintenance procedures	6-2
6.3	Maintenance of analyzer unit	6-2
6.3.1	Cleaning method for sample cell (pipe cell).....	6-2
6.3.2	Cleaning method for sample cell (block cell)	6-4
6.3.3	Optical zero adjustment method (optical balance adjustment)	6-6
6.3.4	Moisture interference compensation adjustment method	6-7
6.3.5	Replacement of fuse on analyzer unit	6-8
6.4	Inspection and maintenance of limited service-life components	6-9
7.	TROUBLE SHOOTING	7-1
7.1	Error message	7-1
7.2	Troubleshooting	7-3
	Customer Maintenance Parts List	CMPL 11G02N01-01E
	Revision Information	i

1. OVERVIEW

This infrared gas analyzer (type: IR400) measures the concentration of NO, SO₂, CO₂, CO and CH₄ contained in sampling gas on the principle that different atomic molecules have an absorption spectrum in the wave band of infrared rays, and the intensity of absorption is determined by the Lambert-Beer law.

Since this instrument incorporates a compact paramagnetic O₂ sensor, it allows measuring up to 5 components simultaneously by using the built-in O₂ sensor (up to 4 components if O₂ sensor is excluded).

Furthermore, use of a microprocessor or large sized liquid crystal display realizes improvement of operability, accuracy and multi-functions.

This instrument is optimum for measuring combustible gas exhausted from boilers or incinerators, and it is effective for steel gas analysis (blast furnace, steel converter, thermal treatment furnace, sintering (Pellet equipment), coke furnace), storage and maturity of vegetable and fruit, biochemistry (microbe), [fermentation], air pollution [incinerator, exhaust gas desulfurization, denitration], automotive emission (excluding tester), protection against disasters [detection of explosive gas and toxic gas, combustion gas analysis of new building material], growth of plants, chemical analysis [petroleum refinery plant, petroleum chemistry plant, gas generation plant], environment [land concentration, tunnel concentration, parking lot, building management] and various physical and chemical experiments.

1.1 Name and description of main unit

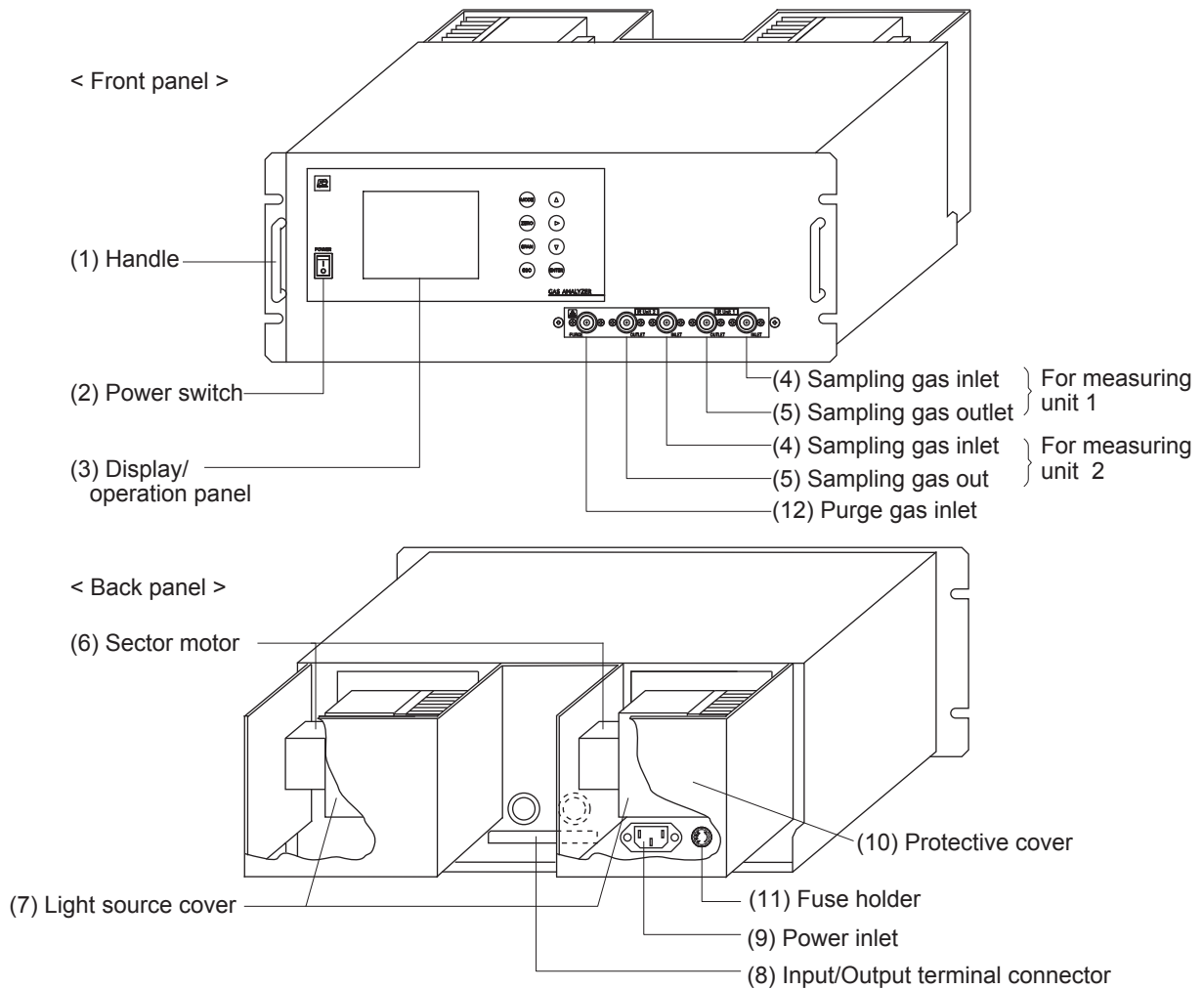

Fig. 1-1

Name	Description	Name	Description
(1) Handle	Used for withdrawing the main unit from the panel.	(6) Sector motor	For driving the rotation of sector.
(2) Power switch	Used for ON/OFF the analyzer.	(7) Light source cover	Infrared light source is arranged in the cover.
(3) Display/operation panel	Liquid crystal display and keys for setting various functions.	(8) Input/Output terminal connector	For connecting to the external input/output terminal module.
(4) Sampling gas inlet	For connecting to the measuring gas tube.	(9) Power inlet	For connecting the power cable.
(5) Sampling gas outlet	Connect to the exhaust line. (A pair of sampling gas inlet/outlet is provided for each measuring unit. When ordered with purge, the piping to measuring unit 2 is built inside. In this case, the sample gas outlet for measuring unit 2 is used for purge gas inlet.)	(10) Protective cover	Protective cover for the light source and the motor. May be removed during operation.
		(11) Fuse holder	Glass fuse for AC power inlet is built in. Fuse is wired only at LIVE side of single-phase two-wire type of AC power.
		(12) Purge gas inlet	

1.2 Input/Output terminal module

IR400 provides input/output of various signals from the supplied input/output terminal modules by connecting the instrument to the module.

< Input/Output terminal module >

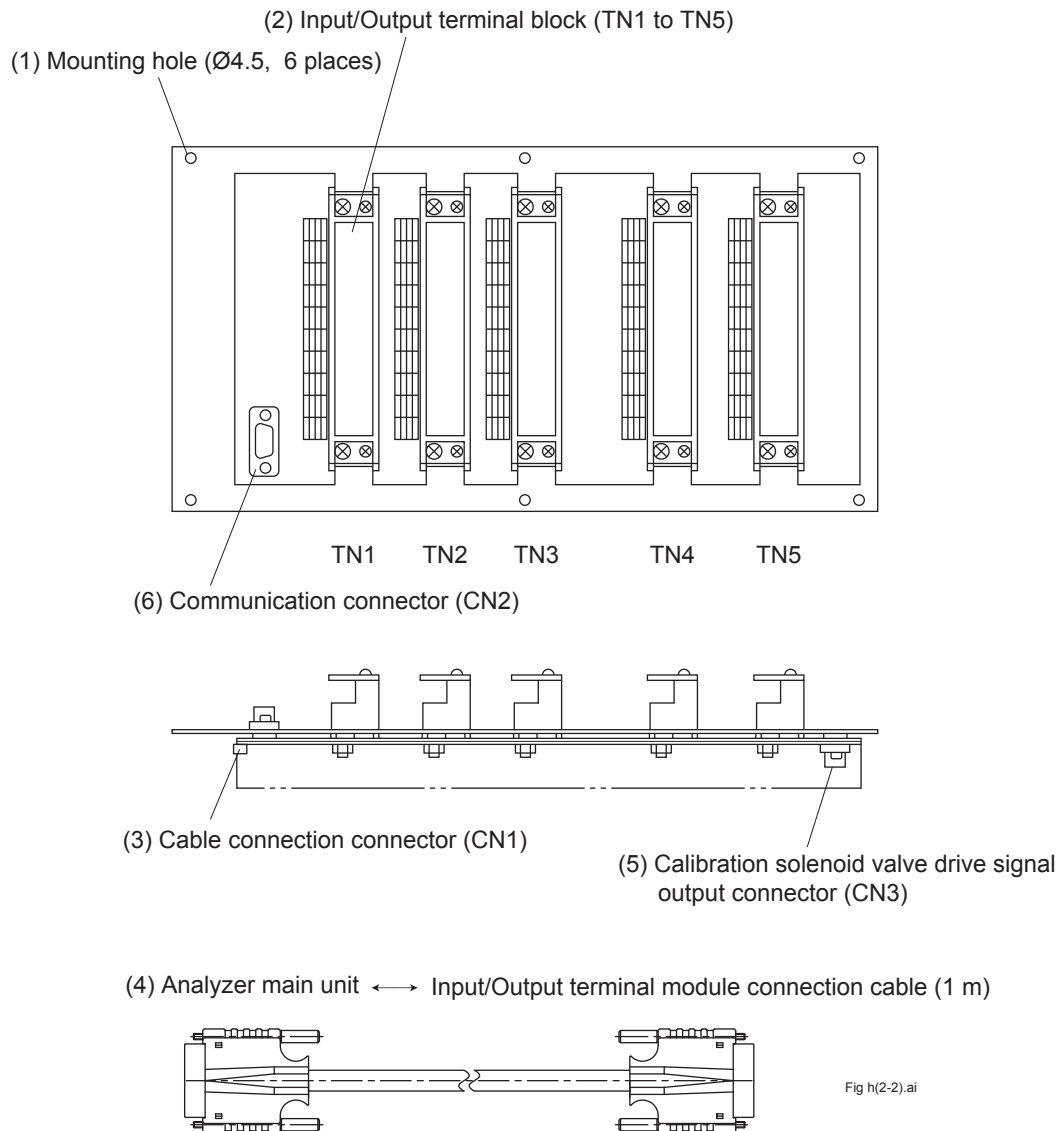

Fig h(2-2).ai

Fig. 1-2

Name	Description	Name	Description
Mounting hole	Used for mounting input/output terminal module. Ø4.5, 6 places	Connector (CN2)	Connect communication cable. *Refer to another manual (IM 11G02P01-01E) about communication function.
Input/Output terminal block (TN 1 to TN 5)	Input/Output terminal for signals of analog output, range identification contact, alarm contact output, etc.	Connector (CN3)	Cable connector for connecting the analyzer to the relay board for automatic calibration
Input/Output terminal module connector (CN1)	Used for connecting the analyzer main unit and the input/output terminal module	Cable for connecting Input/Output Terminal	Used for connecting the analyzer main unit to the input/output terminal module.

2. SPECIFICATIONS

Refer to GS 11G02N01-01E for updated information.

2.1 Standard Specifications

Measurement principle:

NO, SO₂, CO₂, CO, CH₄: Non-dispersive infrared method
Single light source-double beams

O₂: Paramagnetic type (built-in), or zirconia type (external)

Measurable gas components and measuring ranges:

Component \ Range	Minimum range	Maximum range
NO	0 – 50 ppm	0 – 5000 ppm
SO ₂	0 – 50 ppm	0 – 10 vol%
CO ₂	0 – 20 ppm	0 – 100 vol%
CO	0 – 50 ppm	0 – 100 vol%
CH ₄	0 – 200 ppm	0 – 100 vol%
O ₂ (paramagnetic)	0 – 5 vol%	0 – 25 vol%
O ₂ (zirconia)	0 – 5 vol%	0 – 25 vol%

- Measurement of up to 5 components including O₂.
- 1 or 2 measuring range per component.
- Measuring range ratio
 - ≤ 1:5 (O₂ analyzer)
 - ≤ 1:25 (except O₂ analyzer)

For measurable components and possible combinations of measuring ranges, refer to Measurable Components and Ranges page 10 through 11.

Display: Digital indication in 4 digits (LCD with backlight)

- Instantaneous value of each component
- Instantaneous value after O₂ correction (only in NO, SO₂, CO with O₂ measurement)
- Average value after O₂ correction (only in NO, SO₂, CO with O₂ measurement)
- Average O₂ value

Analog output signal:

4 to 20 mA DC or 0 to 1 V DC,
non-isolated, 12 points max.

Analog output corresponds one-to-one with measured value indication.

* Input/Output of analog signals is available in combination with the input/output terminal module.

Permissible load resistance:

550 Ω max. for 4 to 20 mA DC

100 kΩ min. for 0 to 1 V DC

*: Refer to the table “Measurable Components and the Corresponding Channel Numbers” of Page 17, for the channel numbers of displayed values and analog output signals.

Analog Input Signal :

For signal input from external O₂ analyzer,

Signal requirement;

- (1) Signal from Yokogawa's zirconia O₂ analyzer (Model ZX8D*C or ZX8D*D)
- (2) 0 to 1V DC from an O₂ sensor Input section is not isolated. This feature is effective when built-in O₂ sensor is not used.

(An input signal triggers measured concentration indication and O₂ correction.)

*: External O₂ analyzer should be purchased separately.

Relay contact output:

1a contact (250 V AC/2 A, resistive load)

Instrument error, calibration error, range identification, auto calibration status, pump ON/OFF, peak alarm.

1c contact (250 V AC/2 A, resistive load)
 Selectable 6 outputs.
 High/Low limit alarm contact output (for each channel).
 Power disconnection alarm.

* All relay contacts are isolated mutually and from the internal circuit.

Contact input:

Non-voltage contact (ON/0 V, OFF/5 VDC, 5 mA flowing at ON). Remote range changeover, auto calibration remote start, remote hold, average value reset, pump ON/OFF. Isolated from the internal circuit with photocoupler. Contact inputs are not isolated from one another.

Transmission output:

Solenoid valve drive signal for automatic calibration. Transistor output (100 mA or less)

* For details, see External Connection Diagram on page 16.

Power supply:

Voltage rating; 100 to 240 V AC
 Allowable range; 85 to 264 V AC
 Frequency; 50/60 Hz
 Power consumption; 250 VA max.
 Inlet; Conform to EN60320
 Protection Class 1

Operating conditions:

Ambient temperature; -5 to 45°C
 Ambient humidity; 90%RH max., non-condensing.

Storage conditions:

Ambient temperature; -20 to 60°C
 Ambient humidity; 90%RH max, non-condensing

Dimensions (H × W × D):

Analyzer main unit;
 177 × 483 × 599 mm
 Input/Output terminal module;
 164 × 316 × 55 mm

Weight: Approx. 22 kg (only analyzer)

Finish color:

Front panel; Off-white (Munsell 10Y7.5/0.5 or equivalent)
 Casing; Plating, Steel-blue (gray)

Enclosure: Steel casing, for indoor use

Material of gas-contacting parts:

Gas inlet/outlet; SUS304
 Sample cell; SUS304/neoprene rubber
 Infrared-ray transmitting window; CaF₂
 O₂ analyzer sampling cell; SUS316
 Internal piping; Toaron tube, Teflon tube

Gas inlet/outlet: Rc1/4 or 1/4 NPT internal thread

Purge gas flow rate: 1 L/min (when required)

Safety, EMC and RoHS conformity standards:

When using IR400 in Europe, select a suffix code of "Indication, Power cable":C in the suffix code.

Installation altitude; 2000 m or less

Pollution degree; 2 (Note)

Installation category; II (Note)

Note: Installation category, called overvoltage category, specifies impulse with standing voltage. Category II is for electrical equipment.

Pollution degree indicates the degree of existence of solid, liquid, gas or other inclusions which reduce dielectric strength. Degree 2 is the normal indoor environment.

Safety; EN61010-1

EMC; EN61326-1 Class A, Table 2, EN61326-2-3,
 EN61000-3-2, EN61000-3-3, EN61000-6-2
 EMC Regulatory Arrangement in Australia and New Zealand (RCM)
 Korea Electromagnetic Conformity (KC)

Note: The product mounted in a steel enclosure conforms to the requirements of EMC directive.

Caution: The instrument is a Class A product, and it is designed for use in the industrial environment. Please use this instrument in the industrial environment only.

RoHS; EN50581

Information of the WEEE Directive

This product is purposely designed to be used in a large scale fixed installations only and, therefore, is out of scope of the WEEE Directive. The WEEE Directive does not apply. The WEEE Directive is only valid in the EU.

Options**Dedicated relay board (Option code: /R)**

This relay board receives signals from connector CN3 of the IR400 I/O terminal module and activates the calibration solenoid valve directly.

Relay Contact 1a contact (250 V AC/2 A, resistive load)

Contact Action

During measurement; CN1: ON
 Others: OFF

During calibration: CN1: OFF
 Others: Contact corresponding to calibration timing is ON

Recommended connector (CN1 to CN9)

Housing; VHR-2N (JST, Japan Solderless Terminals,)

Contact; SVH-21T-1-1 (JST)

Standard Functions**Output signal hold:**

Output signals are kept on hold during the manual or auto calibrations by activation of holding (turning "ON" its setting).

The values to be on hold are the ones obtained just before calibration mode starts. Indication values will not be on hold.

Remote output hold:

Output signal holds the latest value or setting value by short-circuiting the remote-output-hold input terminals.

Holding is maintained while the terminals are short-circuited. But the indicated instantaneous values will not be on hold.

Switch range :

The range changeover is available in manual, auto, and remote modes. Only preset changeover method is valid.

Manual; Allows range to switch by key operation.

Auto; Allows range to switch from low to high range when 90%FS or more is available in the low range.

Allows range to switch from high to low range when 80%FS or less is available in the low range.

Remote; Non-voltage contact input (for measurable components)

Allows range to switch via an external signal when remote range changeover input is received.

Range identification signal:

The present measuring range is identified by a contact signal.

The contact output terminals for each component are short-circuited when the first range is selected, and when the second range is selected, the terminals are open.

Auto calibration:

Auto calibration is carried out periodically at a preset cycle.

When a standard gas cylinder for calibration and a solenoid valve for opening/closing the gas flow line are prepared externally by the customer, calibration will be carried out with the solenoid valve drive contacts for zero calibration and each span calibration turned on/off sequentially at the set auto calibration timing.

Auto calibration cycle setting;

Auto calibration cycle is set.

Setting is variable within 1 to 99 hours (in increments of 1 hour) or 1 to 40 days (in increments of 1 day).

Gas flow time setting;

The time for flowing each calibration gas in auto calibration is set.

Settable within 60 to 900 seconds (in increments of 1 second)

Auto calibration remote start:

Auto calibration is carried out only once according to an external input signal. Calibration sequence is settable in the same way as the general auto calibration.

Auto calibration starts by opening the auto-calibration-remote-start input terminals after short-circuiting them for 1.5 seconds or longer.

Auto zero calibration:

Auto zero calibration is carried out periodically at the preset cycle.

This cycle is independent of "Auto calibration" cycle.

When zero calibration gas and solenoid valve for opening/closing the calibration gas flow line are prepared externally by the customer, the zero calibration will be carried out at the preset auto zero calibration timing with the solenoid valve drive contact (for zero calibration) turned on/off.

Auto zero calibration cycle setting;

Auto zero calibration cycle is set.

Setting is variable within 1 to 99 hours (in increments of 1 hour) or 1 to 40 days (in increments of 1 day)

Gas flow time setting;

The time for flowing zero gas in auto zero calibration is set.

Settable 60 to 900 seconds (in increments of 1 second)

Upper/lower limit alarm:

Alarm contact output turns on when measurement value reaches the preset upper or lower limit of alarm value.

Contacts close when the instantaneous value of each component becomes larger than the upper alarm limit value or smaller than the lower alarm limit value.

Instrument error contact output:

Contacts close at an occurrence of analyzer error No. 1, 3 or 10.

Calibration error contact output:

Contacts close at occurrence of manual or auto calibration error (any of errors No. 4 to 9).

Auto calibration status contact output:

Contacts close during auto calibration.

Pump ON/OFF contact output:

During measurement, contacts close. While calibration gas is flowing, contacts open.

Contacts are connected in power supply of pump, and stop the sample gas while calibration gas is flowing.

Optional Functions (available with specifying optional code)

O₂ correction: (-/K)

Conversion of measured NO, SO₂ and CO gas concentrations into values at reference O₂ concentration.

$$\text{Correction formula: } C = \frac{21 - O_n}{21 - O_s} \times C_s$$

Where:

C: Sample gas concentration after O₂ correction

C_s: Measured concentration of sample gas

O_s: Measured O₂ concentration (limit setting: 1 to 20%O₂, default 17%)

O_n: Reference O₂ concentration (value changeable by setting: 0 to 19%O₂, default 4%)

The result of calculation is indicated and output in an analog output signal.

Average value after O₂ correction and O₂ average value calculation (-/K):

The result of O₂ correction or instantaneous O₂ value can be outputted as an average value in the determined period of time.

Used for averaging is the moving average method in which sampling is carried out at intervals of 30 seconds.

(Output is updated every 30 seconds. It is the average value in the determined period of time just before the latest updating.)

Averaging time is settable within 1 to 59 minutes (in increments of 1 minute) or 1 to 4 hours (in increments of 1 hour).

Average value reset (-/K):

The above-mentioned output of average value starts from the initial state by opening the average-value-resetting input terminals after short-circuiting them for 1.5 seconds or longer.

Output is reset by short-circuiting and restarted by opening.

CO concentration peak count alarm (-/A):

(available only for CO + O₂ measurement)

Alarm output turns on according to the preset concentration and count.

Whenever the instantaneous value of CO exceeds the preset concentration value, count

increments. If the count exceeds the preset value in one hour, the alarm contacts close.

Communication function (-/C):

RS-232C (9 pins D-sub)

Half-duplex bit serial

Start-stop synchronization

Modbus™ protocol

Contents; Read/write parameters

Read measurement concentration and instrument status

Remark; When connecting via RS-485 interface, a RS-232C ↔ RS-485 converter should be used.

Performance

Repeatability: ±0.5% of full scale (±1% of full scale for range less than 0-50 ppm)

Linearity: ±1% of full scale

Zero drift: ±1% of full scale/week

(±2% of full scale/week for range equal to or more than 50 ppm and less than 200ppm)

(±2% of full scale/day for range less than 0-50 ppm)

Span drift: ±2% of full scale/week

(±2% of full scale/day for range less than 0-50 ppm)

Response time (for 90%FS response) :

Within 60 seconds including replacement time of sample gas (when gas flow rate is 0.5 L/min). Gas replacement time depends on the number of measuring components, and measuring range effects of interfering gases.

Effects of interfering gases:

When sample gas contains gas components listed below, the measurement accuracy may suffer. Consult Yokogawa for the countermeasures or the effect on accuracy.

Analyzer	Interference gas	Effect
SO ₂ analyzer	NO ₂	50 ppm of NO ₂ is equivalent to -6 ppm of SO ₂
CO analyzer	CO ₂	10 % of CO ₂ is equivalent to 3 ppm of CO
	N ₂ O	1000 ppm of N ₂ O is equivalent to 80 ppm of CO
CH ₄ analyzer	CO ₂	15% of CO ₂ is equivalent to 3 ppm of CH ₄

Standard Requirements for Sample Gas

Flow rate: 0.5±0.2 L/min

Temperature: 0 to 50°C

Pressure: 10 kPa or less (Gas outlet side should be open to the atmospheric air.)

Dust: 100 µg/Nm³ or less in particle size of 1 µm or less

Mist: Unallowable

Moisture: Below a level where saturation occurs at 2°C (condensation unallowable).

Corrosive component: HCl 1 ppm or less

Standard gas for calibration:

Zero gas: Dry N₂

Span gas: Each sample gas having concentration 90 to 100% of its measuring range (recommended).

Gas beyond concentration 100%FS is unusable.

In case a zirconia O₂ analyzer is installed externally and calibration is carried out on the same calibration gas line:

Zero gas; Dry air or atmospheric air (provided without CO₂ sensor)

Span gas; For other than O₂ measurement, each sample gas having concentration 90 to 100% of its measuring range.

For O₂ measurement, O₂ gas of 1 to 2 vol%.

Installation Requirements

•Indoor use: Avoid exposure to direct sunlight, weather, and radiant heat from hot substances. Where the exposure to such conditions are unavoidable, a protective hood or cover should be prepared.

•Minimal vibration

•A clean atmosphere

Model	Suffix code	Option code	Description
4th Component 1st Range (Note 2)	A	-----	0-50 ppm
	B	-----	0-100 ppm
	C	-----	0-200 ppm
	D	-----	0-250 ppm
	W	-----	0-300 ppm
	E	-----	0-500 ppm
	F	-----	0-1000 ppm
	G	-----	0-2000 ppm
	H	-----	0-5000 ppm
	J	-----	0-1%
	K	-----	0-2%
	L	-----	0-3%
	M	-----	0-5%
	P	-----	0-10%
Q	-----	0-20%	
R	-----	0-40%	
S	-----	0-50%	
T	-----	0-70%	
U	-----	0-100%	
N	-----	Not Available	
4th Component 2nd Range (Note 2)	B	-----	0-100 ppm
	C	-----	0-200 ppm
	D	-----	0-250 ppm
	W	-----	0-300 ppm
	E	-----	0-500 ppm
	F	-----	0-1000 ppm
	G	-----	0-2000 ppm
	H	-----	0-5000 ppm
	J	-----	0-1%
	K	-----	0-2%
	L	-----	0-3%
	M	-----	0-5%
	P	-----	0-10%
	Q	-----	0-20%
R	-----	0-40%	
S	-----	0-50%	
T	-----	0-70%	
U	-----	0-100%	
N	-----	Not available	
O ₂ Analyzer 1st Range (Note 2)	1	-----	0-5%
	2	-----	0-10%
	3	-----	0-25%
	N	-----	Not available
O ₂ Analyzer 2nd Range (Note 2)	2	-----	0-10%
	3	-----	0-25%
	N	-----	Not available
Output	-4	-----	4-20 mA DC, non-isolation
	-1	-----	0-1 V DC, non-isolation
Piping	R	-----	Rc1/4
	T	-----	1/4 NPT
Indication, Power Cable (Note 6)	W	-----	Japanese, Power Cable: rated voltage 125 V AC
	L	-----	English, Power Cable: rated voltage 125 V AC (UL)
	C	-----	English, Power Cable: rated voltage 250 V AC (CEE)
	K	-----	English, Power Cable: rated voltage 250 V AC (KC)
T	-----	English, Power Cable: rated voltage 125 V AC (BSMI)	
Option	O ₂ correction and O ₂ average (Note 4)	/K	With O ₂ correction and O ₂ average value
	Communication	/A	With peak count alarm (Note 4)
	Internal purge	/C	RS-232C (Note 9)
	Relay board (Note 5)	/P	Analyzer internal purging
		/R	With dedicated cable
		/EQ	EAC with PA (Note 10)
	/ER	EAC (Note 10)	

Notes:

- 1: A signal from the external O₂ analyzer should be 0-1 V DC linear to full scale.
- 2: Possible combinations of ranges are specified in separate tables.
- 3: Only available for CO₂ measurement. Option code "/P" Analyzer internal purging, must be specified.
- 4: O₂ correction is available only for NO, CO, and SO₂. Both average value output after O₂ correction and average O₂ value output are provided at the same time.
A peak count alarm can be provided only for CO measurement.
- 5: Should be specified when using a solenoid valve for automatic calibration.
- 6: Each type of cable is different in its voltage rating and plug type. Select an appropriate code according to the operating power supply voltage to be used in each field. W is for Japan, L is for North America, and C for Europe, K for Korea, and T for Taiwan. When using IR400 in Europe, select C.
- 7: Specify Style Code D for ZX8D complying with the directives of CE Marking
- 8: For NO_x measurement, a NO₂/NO converter (P/N K9350LE or K9350LF) should be purchased separately.

- 9: Should be specified when using ModbusTM communication.
 10: "/EQ" is EAC with Pattern Approval for Russia. "/ER" is EAC for Kazakhstan and Belarus.

■ Standard Accessories

Name	Qty	Description
Power cable	1	Standard inlet type Part number and (suffix code): K9218SA (W): for Japan 2 m K9358UC (L): for North America 2 m, K9358UB (C): for Europe 2 m, A1004WD(K): for Korea 2.5 m, A1100WD(T): for Taiwan 2 m
Fuse	2	Replacement fuse (250 V AC, 3.15 A, delay type) Part number: K9218SB
Input/output terminal module	1	External terminal module
Cable	1	Connection cable between main unit and input/output terminal module (1 m)
Slide rail	2	Slide rail Part number: K9218SE

■ Measurable component and range - availability check table -

Table 2.1 Single-component analyzer (NO, SO₂, CO₂, CO or CH₄)

2nd range \ 1st range	A	B	C	D	W	E	F	G	H	J	K	L	M	P	Q	R	S	T	U	N
	0-50 ppm	0-100 ppm	0-200 ppm	0-250 ppm	0-300 ppm	0-500 ppm	0-1000 ppm	0-2000 ppm	0-5000 ppm	0-1 %	0-2 %	0-3 %	0-5 %	0-10 %	0-20 %	0-40 %	0-50 %	0-70 %	0-100 %	None
V 0-20 ppm	◇	◇	◇	◇	◇	◇	—	—	—	—	—	—	—	—	—	—	—	—	—	◇
A 0-50 ppm	—	■□ ◇○	■□ ◇○	■□ ◇○	■□ ◇○	■□ ◇○	■□ ◇○	■□ ◇○	—	—	—	—	—	—	—	—	—	—	—	■□ ◇○
B 0-100 ppm	—	—	■□ ◇○	■□ ◇○	■□ ◇○	■□ ◇○	■□ ◇○	■□ ◇○	—	—	—	—	—	—	—	—	—	—	—	■□ ◇○
C 0-200 ppm	—	—	—	■□ ◇○ ▲	■□ ◇○ ▲	■□ ◇○ ▲	■□ ◇○ ▲	■□ ◇○ ▲	■□ ◇○ ▲	—	—	—	—	—	—	—	—	—	—	■□ ◇○ ▲
D 0-250 ppm	—	—	—	—	—	—	■□ ◇○ ▲	■□ ◇○ ▲	■□ ◇○ ▲	—	—	—	—	—	—	—	—	—	—	■□ ◇○ ▲
W 0-300 ppm	—	—	—	—	—	—	■□ ◇○ ▲	■□ ◇○ ▲	■□ ◇○ ▲	—	—	—	—	—	—	—	—	—	—	■□ ◇○ ▲
E 0-500 ppm	—	—	—	—	—	—	■□ ◇○ ▲	■□ ◇○ ▲	■□ ◇○ ▲	○◇ ○▲	—	—	—	—	—	—	—	—	—	■□ ◇○ ▲
F 0-1000 ppm	—	—	—	—	—	—	—	■□ ◇○ ▲	■□ ◇○ ▲	○◇ ○▲	○◇ ○▲	—	—	—	—	—	—	—	—	■□ ◇○ ▲
G 0-2000 ppm	—	—	—	—	—	—	—	—	■□ ◇○ ▲	○◇ ○▲	○◇ ○▲	◇▲ ◇▲	—	—	—	—	—	—	—	■□ ◇○ ▲
H 0-5000 ppm	—	—	—	—	—	—	—	—	—	○◇ ○▲	○◇ ○▲	○◇ ○▲	○◇ ○▲	○◇ ○▲	—	—	—	—	—	■□ ◇○ ▲
J 0-1 %	—	—	—	—	—	—	—	—	—	—	○◇ ○▲	○◇ ○▲	○◇ ○▲	○◇ ○▲	○◇ ○▲	—	—	—	—	○◇ ○▲
K 0-2 %	—	—	—	—	—	—	—	—	—	—	—	○◇ ○▲	○◇ ○▲	○◇ ○▲	○◇ ○▲	○◇ ○▲	○◇ ○▲	—	—	○◇ ○▲
L 0-3 %	—	—	—	—	—	—	—	—	—	—	—	—	○◇ ○▲	○◇ ○▲	○◇ ○▲	○◇ ○▲	○◇ ○▲	—	—	○◇ ○▲
M 0-5 %	—	—	—	—	—	—	—	—	—	—	—	—	—	○◇ ○▲	○◇ ○▲	○◇ ○▲	○◇ ○▲	—	—	○◇ ○▲
P 0-10 %	—	—	—	—	—	—	—	—	—	—	—	—	—	—	○◇ ○▲	○◇ ○▲	○◇ ○▲	○◇ ○▲	○◇ ○▲	○◇ ○▲
Q 0-20 %	—	—	—	—	—	—	—	—	—	—	—	—	—	—	—	○◇ ○▲	○◇ ○▲	○◇ ○▲	○◇ ○▲	○◇ ○▲
R 0-40 %	—	—	—	—	—	—	—	—	—	—	—	—	—	—	—	—	○◇ ○▲	○◇ ○▲	○◇ ○▲	○◇ ○▲
S 0-50 %	—	—	—	—	—	—	—	—	—	—	—	—	—	—	—	—	—	○◇ ○▲	○◇ ○▲	○◇ ○▲
T 0-70 %	—	—	—	—	—	—	—	—	—	—	—	—	—	—	—	—	—	—	○◇ ○▲	○◇ ○▲
U 0-100 %	—	—	—	—	—	—	—	—	—	—	—	—	—	—	—	—	—	—	—	○◇ ○▲

◇ : CO₂ analyzer measurable range ○ : CO analyzer measurable range ▲ : CH₄ analyzer measurable range
 □ : SO₂ analyzer measurable range ■ : NO analyzer measurable range

Table 2.2 Two-component analyzer (NO and SO₂)

1st component (NO),1st range			2nd component (SO ₂) 1st range -----> SO ₂								
			A	B	C	D	W	E	F	G	H
			0-50ppm	0-100ppm	0-200ppm	0-250ppm	0-300ppm	0-500ppm	0-1000ppm	0-2000ppm	0-5000ppm
NO	A	0-50ppm	○ *1	○ *2	○ *2	○ *2	○ *2	○ *2	○ *2	○ *2	—
	B	0-100ppm	○ *3	○ *4	○ *4	○ *4	○ *4	○ *4	○ *4	○ *4	—
	C	0-200ppm	○ *3	○ *4	○ *5	○ *5	○ *5	○ *5	○ *5	○ *5	○ *5
	D	0-250ppm	○ *3	○ *4	○ *5	○ *5	○ *5	○ *5	○ *5	○ *5	○ *5
	W	0-300ppm	○ *3	○ *4	○ *5	○ *5	○ *5	○ *5	○ *5	○ *5	○ *5
	E	0-500ppm	○ *3	○ *4	○ *5	○ *5	○ *5	○ *5	○ *5	○ *5	○ *5
	F	0-1000ppm	○ *3	○ *4	○ *5	○ *5	○ *5	○ *5	○ *5	○ *5	○ *5
	G	0-2000ppm	○ *3	○ *4	○ *5	○ *5	○ *5	○ *5	○ *5	○ *5	○ *5
	H	0-5000ppm	—	—	○ *5	○ *5	○ *5	○ *5	○ *5	○ *5	○ *5

○ : Double components measurable range. 1st component : NO, 2nd component : SO₂.

1st range (low range) must meet the combination in table above.

- *1. 2nd range of both NO and SO₂ measurements are available up to 1000 ppm.
- *2. 2nd range of NO and SO₂ measurements are available up to 1000 ppm and 2000 ppm, respectively.
- *3. 2nd range of NO and SO₂ measurements are available up to 2000 ppm and 1000 ppm, respectively.
- *4. 2nd range of both NO and SO₂ are available up to 2000 ppm.
- *5. 2nd range of both NO and SO₂ are available up to 5000 ppm.

Table 2.3 Two-component analyzer (NO and CO)

Both NO and CO analyzer must meet the range in Table 2.1; Single component analyzer.

Table 2.4 Two-component analyzer (CO₂ and CO)

2nd component (CO) 1st range		CO*											
		A	B	C	D	W	E	F	G	H	J		
		0-50ppm	0-100ppm	0-200ppm	0-250ppm	0-300ppm	0-500ppm	0-1000ppm	0-2000ppm	0-5000ppm	0-1%		
CO ₂	A	0-50ppm	a-a	a-b	a-c	a-c	a-c	a-c	a-c	a-c	a-c	a-z	—
	B	0-100ppm	b-a	b-b	b-c	b-c	b-c	b-d	b-d	b-d	b-d	b-d	b-z
	C	0-200ppm	c-a	c-b	c-c	c-c	c-c	c-d	c-d	c-d	c-d	c-d	c-z
	D	0-250ppm	c-a	c-b	c-c	c-c	c-c	c-d	c-d	c-d	c-d	c-d	c-z
	W	0-300ppm	c-a	c-b	c-c	c-c	c-c	c-d	c-d	c-d	c-d	c-d	c-z
	E	0-500ppm	c-a	c-b	c-c	c-c	c-c	d-d	d-e	d-e	d-e	d-e	d-e
	F	0-1000ppm	c-a	c-b	c-c	c-c	c-c	d-d	e-e	e-e	e-e	e-e	e-e
	G	0-2000ppm	c-a	c-b	c-c	c-c	c-c	d-d	e-e	e-e	f-g	f-g	f-g
	H	0-5000ppm	z-a	z-b	z-c	z-c	z-c	d-d	e-e	e-e	g-g	g-h	g-h
	J	0-1%	—	—	—	—	—	z-d	e-e	e-e	g-g	h-h	h-h
	K	0-2%	—	—	—	—	—	—	z-e	z-e	g-g	h-h	h-h
	L	0-3%	—	—	—	—	—	—	—	—	g-g	h-h	h-h
	M	0-5%	—	—	—	—	—	—	—	—	g-g	h-h	h-h
	P	0-10%	h-a	h-b	h-c	h-c	h-c	h-d	h-d	h-d	z-g h-d	h-h	h-h
	Q	0-20%	z-a	z-b	z-c	z-c	z-c	z-d	z-d	z-d	z-d	z-d	z-h
	R	0-40%	—	—	—	—	—	—	—	—	—	—	—
	S	0-50%	—	—	—	—	—	—	—	—	—	—	—
	T	0-70%	—	—	—	—	—	—	—	—	—	—	—
	U	0-100%	—	—	—	—	—	—	—	—	—	—	—

Symbol definition: (Example) x-y x: Selectable scale of the second range to measure CO₂.

Y: Selectable scale of the second range to measure CO.

a: Selectable up to 1000 ppm.

b: Selectable up to 2000 ppm.

c: Selectable up to 5000 ppm.

d: Selectable up to 1 %.

e: Selectable up to 2 %.

f: Selectable up to 5 %.

g: Selectable up to 10 %.

h: Selectable up to 20 %.

z: Second range is not available. (Only first range is available.)

* : Consult YOKOGAWA for information on any combination of two ranges among K through U when you measure CO as a second component at above 2% level of its first range.

Table 2.5 Three-component analyzer (NO + SO₂ + CO)

See Table 2.2 for NO + SO₂ measurement of three-component analyzer (NO + SO₂ + CO). See Table 2.1 for CO measurement.

Table 2.6 Four-component analyzer (NO + SO₂ + CO₂ + CO)

See Table 2.2 for NO + SO₂ measurement and Table 2.4 for CO₂ + CO measurement.

Table 2.7 O₂ analyzer

1st range \ 2nd range		2	3
		0-10%	0-25%
1	0-5%	○▲	○▲
2	0-10%	—	○▲
3	0-25%	—	○▲

○ : Built-in O₂ analyzer measurable range

▲ : External Zirconia Oxygen Analyzer (in this case, Yokogawa's ZX8D) measurable range

*O₂ analyzer is selectable independently of its combination with other components.

2.3 External Dimensions

<Analyzer main unit>

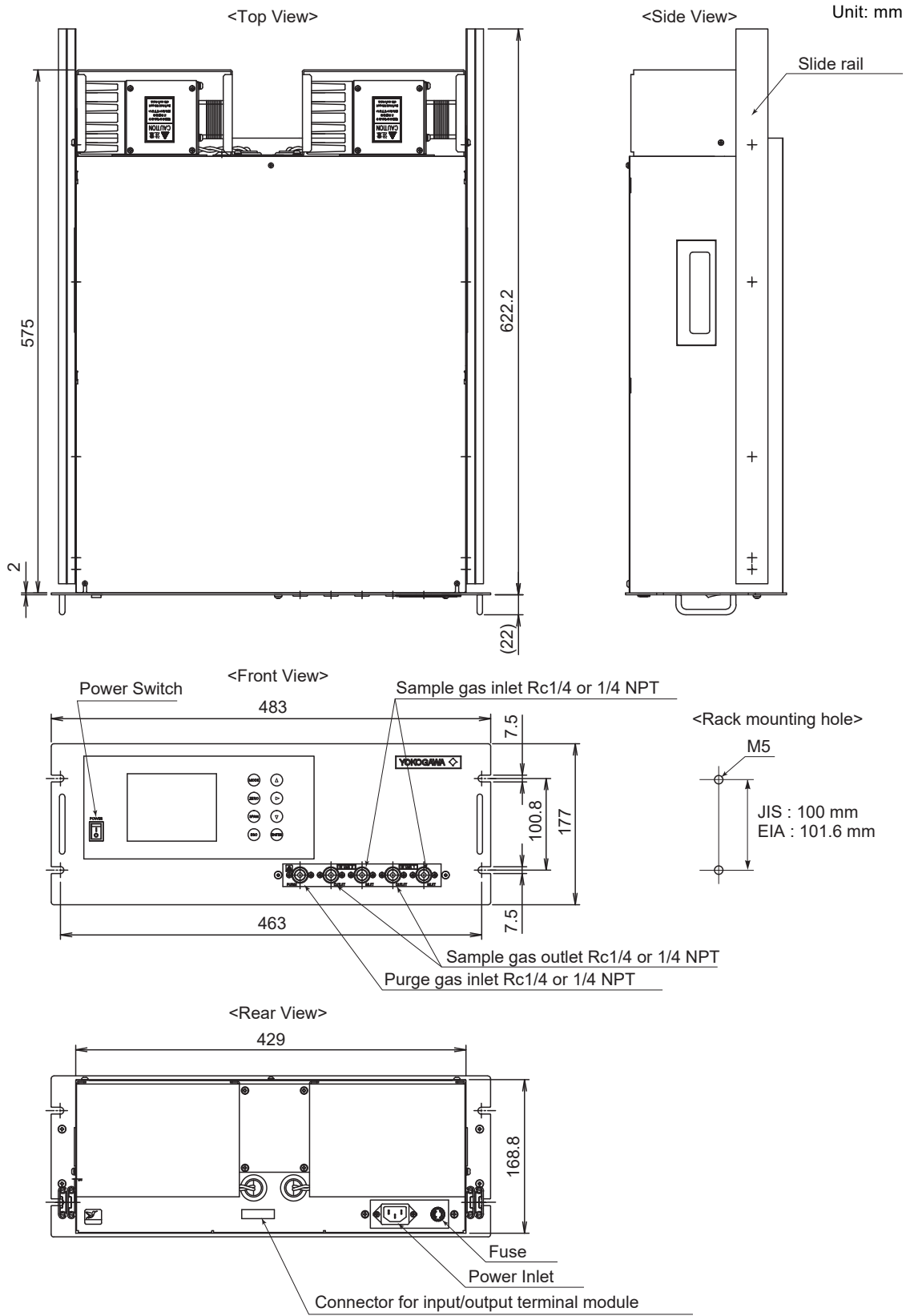

Accessory

• Input/Output Terminal Module

Unit: mm

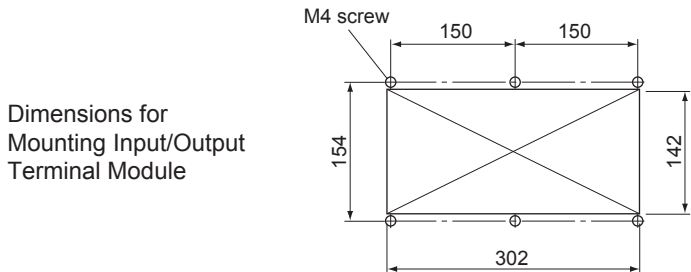
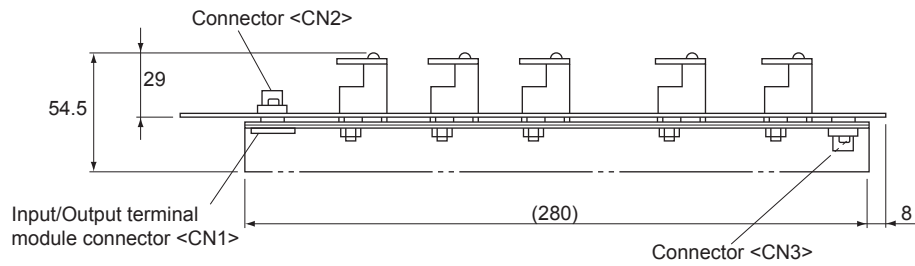
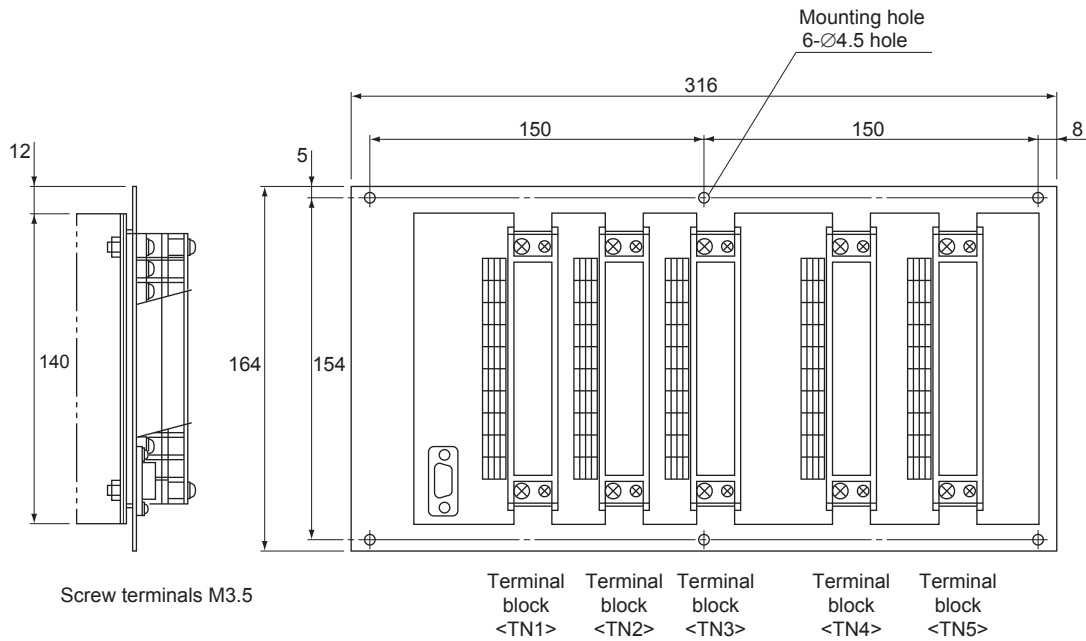

Cut M4 screw holes at 6 positions.
Drill a rectangular hole of 302 x 142 mm or more in the center.

F05.ai

• Cable for connecting Input/Output Terminal

Unit: mm

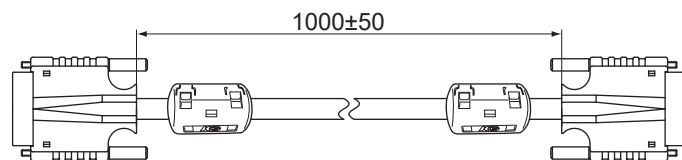

• **Slide Rail**

Model: equivalent to 305A-24/Accuride International Inc.

Unit: mm

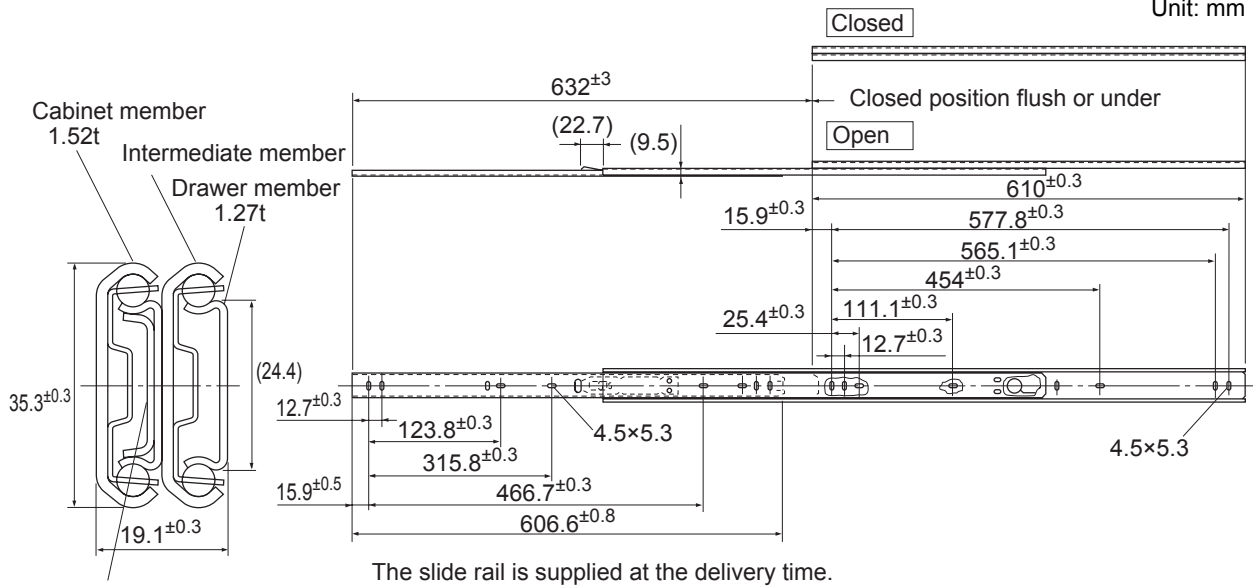

Reinforcement plate

<19-inch rack mounting method>

For easy maintenance, we recommended the mounting method which allows the rack to be drawn out along the slide rail.

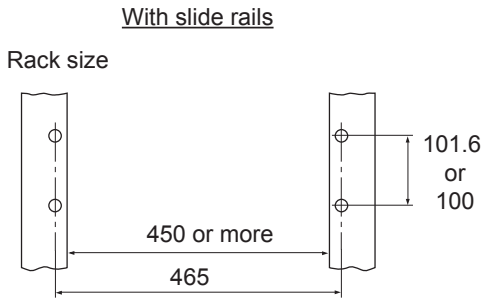

Mounting diagram

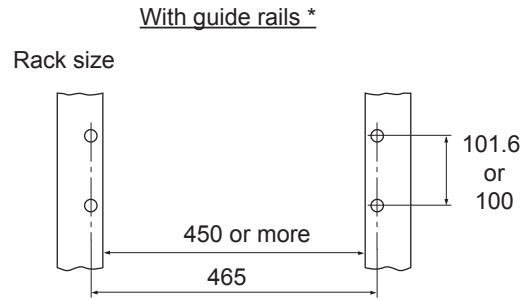
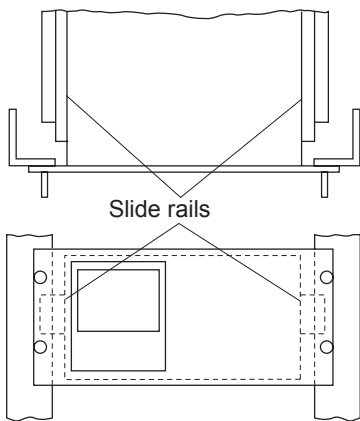

Mounting diagram

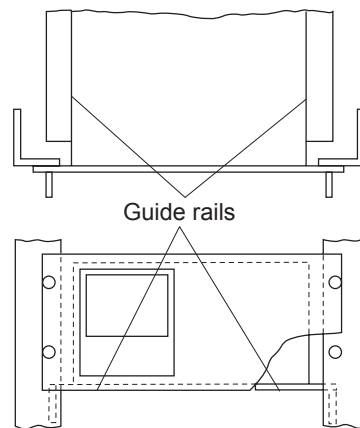

* For mounting with guide rails, a maintenance space (200 mm or more) should be provided on top of the main unit.

Dedicated Relay Board (option code -/R)

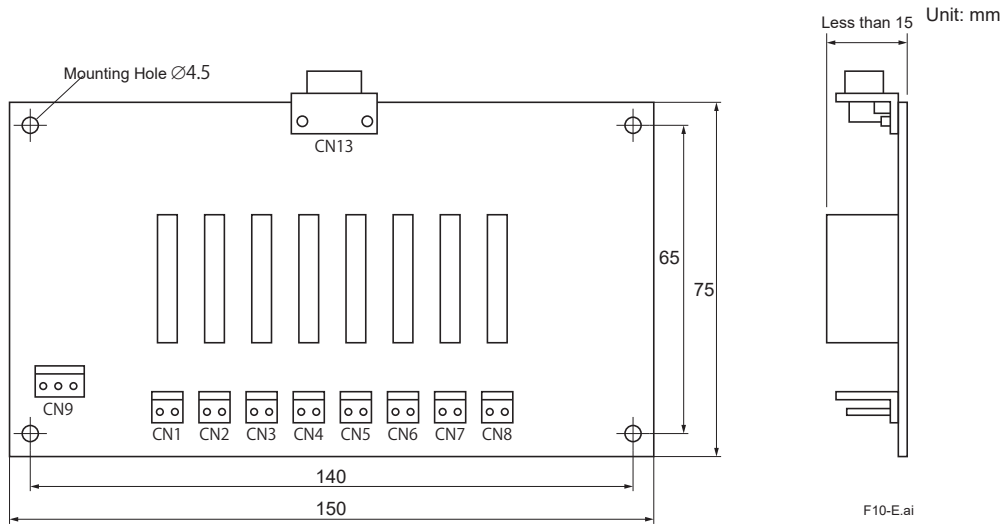

<How to connect>

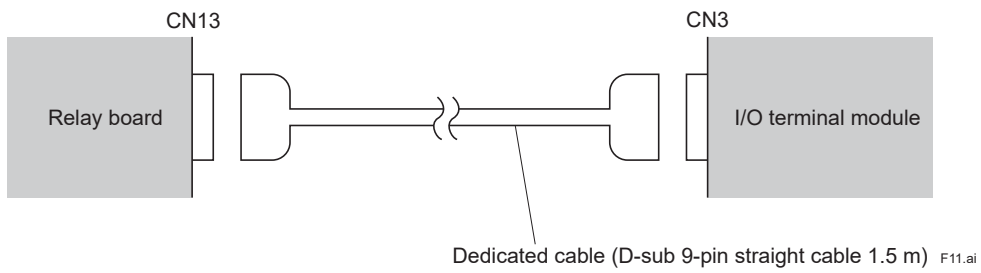
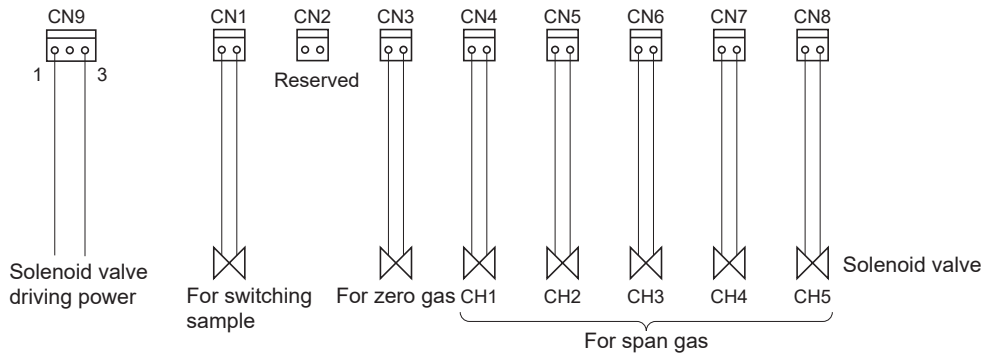

External Connection Diagram

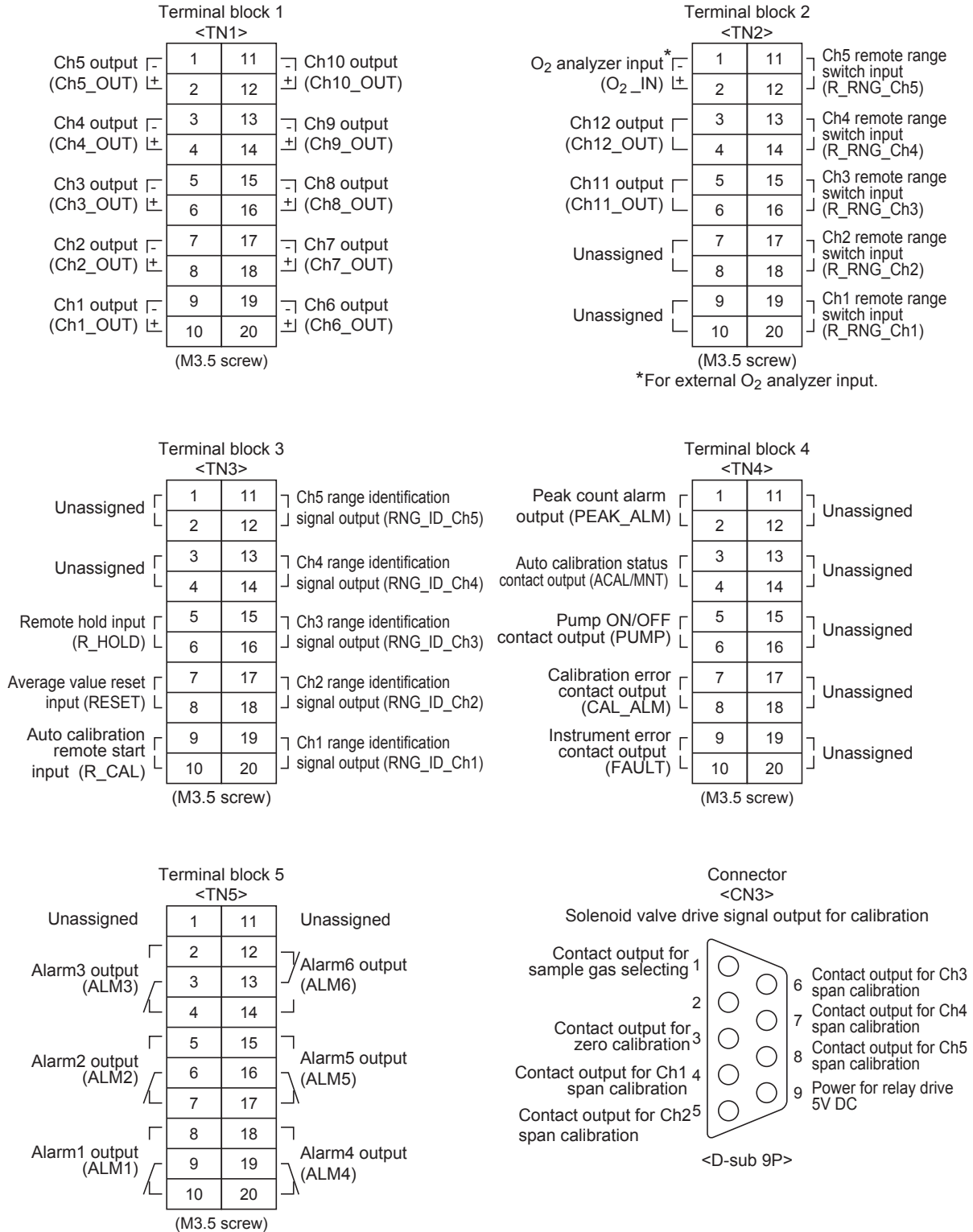

Note 1: Unassigned terminals are used for internal connection. So they should not be used as repeating terminals either.
 Note 2: The allocation of each channel (Ch1 to Ch12) depends on measured gas components. Refer to the table on the next page.

F08.ai

<Measurable Components and the Corresponding Channel Numbers>

Suffix/Option Code			Output and Corresponding Channel											
Measurable component	O ₂ analyzer	Option code*	Ch1	Ch2	Ch3	Ch4	Ch5	Ch6	Ch7	Ch8	Ch9	Ch10	Ch11	Ch12
-A	N	Not specified	NO											
-B	N	Not specified	SO ₂											
-C	N	Not specified	CO ₂											
-D	N	Not specified	CO											
-F	N	Not specified	CH ₄											
-G	N	Not specified	NO	SO ₂										
-H	N	Not specified	NO	CO										
-J	N	Not specified	CO ₂	CO										
-K	N	Not specified	NO	SO ₂	CO									
-L	N	Not specified	NO	SO ₂	CO ₂	CO								
-A	1, 2, 3	/K	NO _x	O ₂	Correct NO _x	Correct NO _x av.	O ₂ av.							
-B	1, 2, 3	/K	SO ₂	O ₂	Correct SO ₂	Correct SO ₂ av.	O ₂ av.							
-D	1, 2, 3	/K	CO	O ₂	Correct CO	Correct CO av.	O ₂ av.							
-F	1, 2, 3	/K	CH ₄	O ₂	O ₂ av.									
-G	1, 2, 3	/K	NO _x	SO ₂	O ₂	Correct NO _x av.	Correct SO ₂	Correct NO _x av.	Correct SO ₂ av.	O ₂ av.				
-H	1, 2, 3	/K	NO _x	CO	O ₂	Correct NO _x	Correct CO	Correct NO _x av.	Correct CO av.	O ₂ av.				
-J	1, 2, 3	/K	CO ₂	CO	O ₂	Correct CO ₂ av.	Correct CO av.	O ₂ av.						
-K	1, 2, 3	/K	NO _x	SO ₂	CO	O ₂	Correct NO _x	Correct SO ₂	Correct CO	Correct NO _x av.	Correct SO ₂ av.	Correct CO av.	O ₂ av.	
-L	1, 2, 3	/K	NO _x	SO ₂	CO ₂	CO	O ₂	Correct NO _x	Correct SO ₂	Correct CO	Correct NO _x av.	Correct SO ₂ av.	Correct CO av.	O ₂ av.
-D	1, 2, 3	/A	CO	O ₂										
-H	1, 2, 3	/A	NO	CO	O ₂									
-J	1, 2, 3	/A	CO ₂	CO	O ₂									
-K	1, 2, 3	/A	NO	SO ₂	CO	O ₂								
-L	1, 2, 3	/A	NO	SO ₂	CO ₂	CO	O ₂							

■ : NO measurement in this area is displayed as NO_x.

*: In the column of Option code, "Not specified" refers the option codes except /K or /A.

Notes: Peak count alarm is a contact output.

"Correct XX" means an instantaneous XX value after O₂ correction, "Correct XX av." an average XX value after O₂ correction, and O₂ av." an average O₂ value.

3. INSTALLATION

WARNING

This unit is Non-Explosion-proof type. Do not use it in a place with explosive gases to prevent explosion, fire or other serious accidents.

CAUTION

- Entrust the installation, movement or re-installation to a specialist or the supplier. A poor installation may cause accidental tip over, shock hazard, fire, injury, etc.
- The gas analyzer is heavy. It should be installed with utmost care. Otherwise, it may tip over or drop, for example, causing accident or injury.
- For lifting the gas analyzer, be sure to wear protective gloves. Bare hands may invite an injury.
- This unit should be installed in a place which conforms to the conditions noted in the instruction manual. Otherwise, it may cause electric shocks, fire or malfunction of the unit.
- During installation work, care should be taken to keep the unit free from entry of cable chips or other foreign objects. Otherwise, it may cause fire, trouble or malfunction of the unit.

3.1 Installation conditions

To install the analyzer for optimum performance, select a location that meets the following conditions;

- (1) This instrument is system built in type. This instrument should be used while embedded in a panel, locker, or enclosure of steel sheet.
- (2) Use this instrument indoors.
- (3) A vibration-free place
- (4) A place which is clean around the analyzer.
- (5) Power supply

Rated voltage :	100 V to 240 V AC
Operating voltage :	85 V to 264 V AC
Rated frequency :	50/60 Hz
Power consumption :	250 VA max.
Inlet :	Conformity to EN60320 Class I type 3-pin inlet
- (6) Operation conditions

Ambient temperature :	-5 to 45°C
Ambient humidity :	90%RH or less, no condensation

3.2 Installation

3.2.1 Installation of analyzer main frame

Installation methods for the analyzer main unit are divided into 2 types;

(Unit : mm)

Type	External dimensions	Mounting dimensions	Mounting method
19 inch rack mounting guide rail method			
19 inch rack mounting slide rail method			

F3_2_1.ai

- Note 1 Check and maintenance of the analyzer main unit may be carried out with the top cover detached. The guide rail method may be used if a space accessible for maintenance is provided at the top of the main unit. If maintenance space is not provided specially, it is recommended to use the slide rail method. Recommended slide rail: Product No.: 305A-24 manufactured by Accuride International Co.
- Note 2 For 19 inch rack mounting, the weight of the analyzer is supported with the bottom of the case (with the side of the case in case of slide rail method). For mounting dimensions of the slide rail, see "Item 9.3 External diagram". Don't install the analyzer at a place which is exposed to direct sunlight. The analyzer should be installed at a place where ambient temperature is within -5 to 45°C, and temperature fluctuation during use is minimum.

3.2.2 Mounting input/output terminal module

Mount the input/output terminal module on the panel; observing the following method.

(Note) To avoid the effect of noise generated from external units, mount the I/O terminal module mounting plate on the panel for continuity at the mounting surface and connect the panel to the same ground as the analyzer main unit.

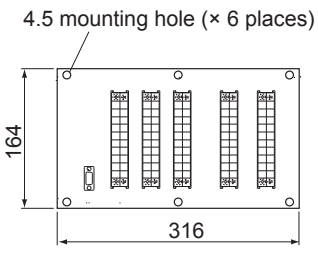
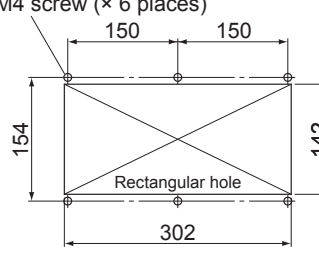
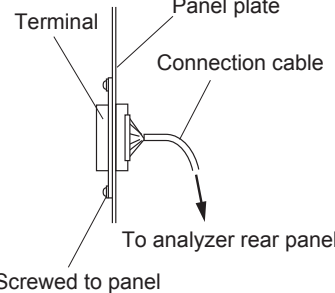
External dimensions	Mounting dimensions	Mounting method
 <p>4.5 mounting hole (× 6 places)</p> <p>164</p> <p>316</p>	 <p>M4 screw (× 6 places)</p> <p>150 150</p> <p>154 142</p> <p>302</p> <p>Rectangular hole</p>	 <p>Terminal</p> <p>Panel plate</p> <p>Connection cable</p> <p>To analyzer rear panel</p> <p>Screwed to panel</p>

p3-03_1.ai

Note: How to ground analyzer main unit and I/O terminal module.
To avoid the effect of noises, etc. from external units, it is recommended to ground them by the procedure described below.

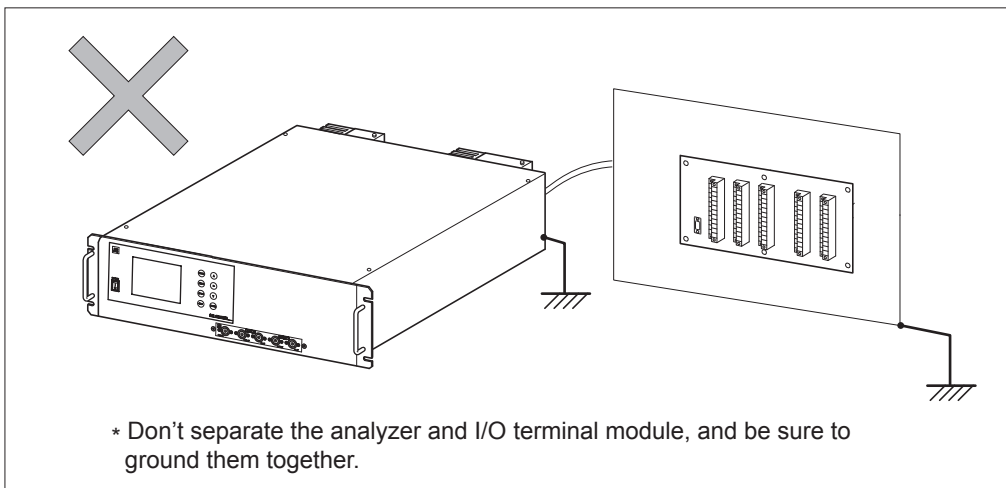
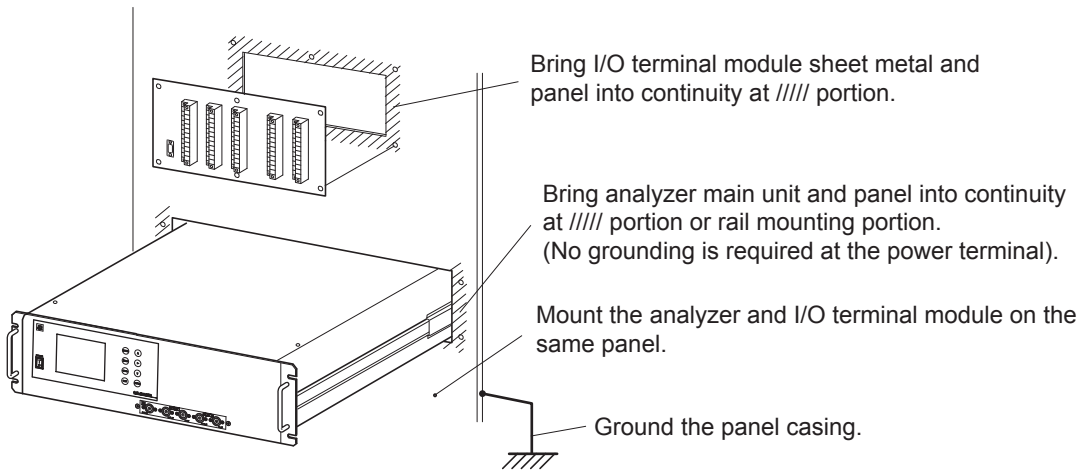

3.3 Piping

Piping should be connected to the gas inlets and outlets of the front panel of the analyzer.

- Use a corrosion resistant tube of Teflon, stainless or polyethylene to connect the instrument to a sampling system. Even if there is a danger of corrosion, refrain from using a tube of rubber or soft vinyl. The instrument provides inaccurate indication due to gas absorption by piping materials.
- Pipe connection port is Rc1/4 female thread (or 1/4 NPT). Piping should be cut as short as possible for a quick response. About 4 mm inner diameter is recommended.
- Entry of dust into the instrument may result in defective operation. Use a clean piping or coupling.

Connect the gas tube by the following method.

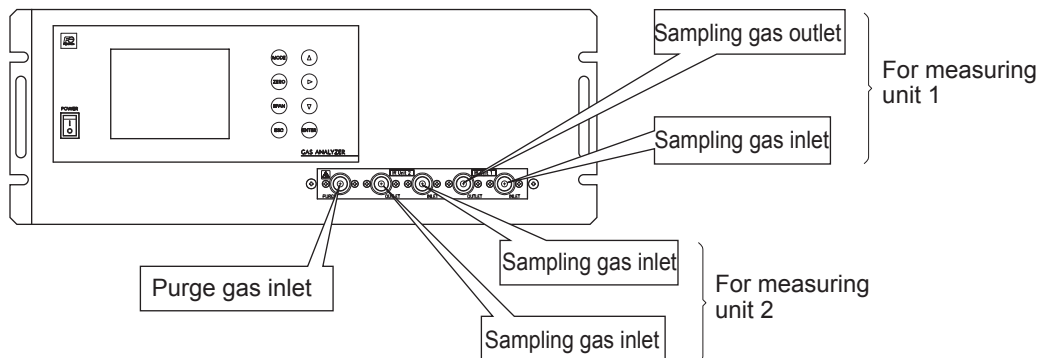

Sampling gas inlet: Attach the gas tube to introduce gas to be measured such as one that has completed dehumidification process and standard gases for zero and span calibration to this inlet. Gas flow to be introduced should be constant within the range of 0.5 ± 0.2 L/min.

Sampling gas outlet: Exhaust measured gas through the outlet. Attach the tube to exhaust measured gas outdoors or to the atmosphere.

Purge gas inlet: It is used for purging the inside of the total gas analyzer. When the analyzer must be purged, refer to Item 3.4.5 Purging of instrument inside. Use dry gas N_2 or instrumentation air for purge gas. (flow rate of 1 L/min or more should be used and no dust or mist is contained).

Internal piping diagram

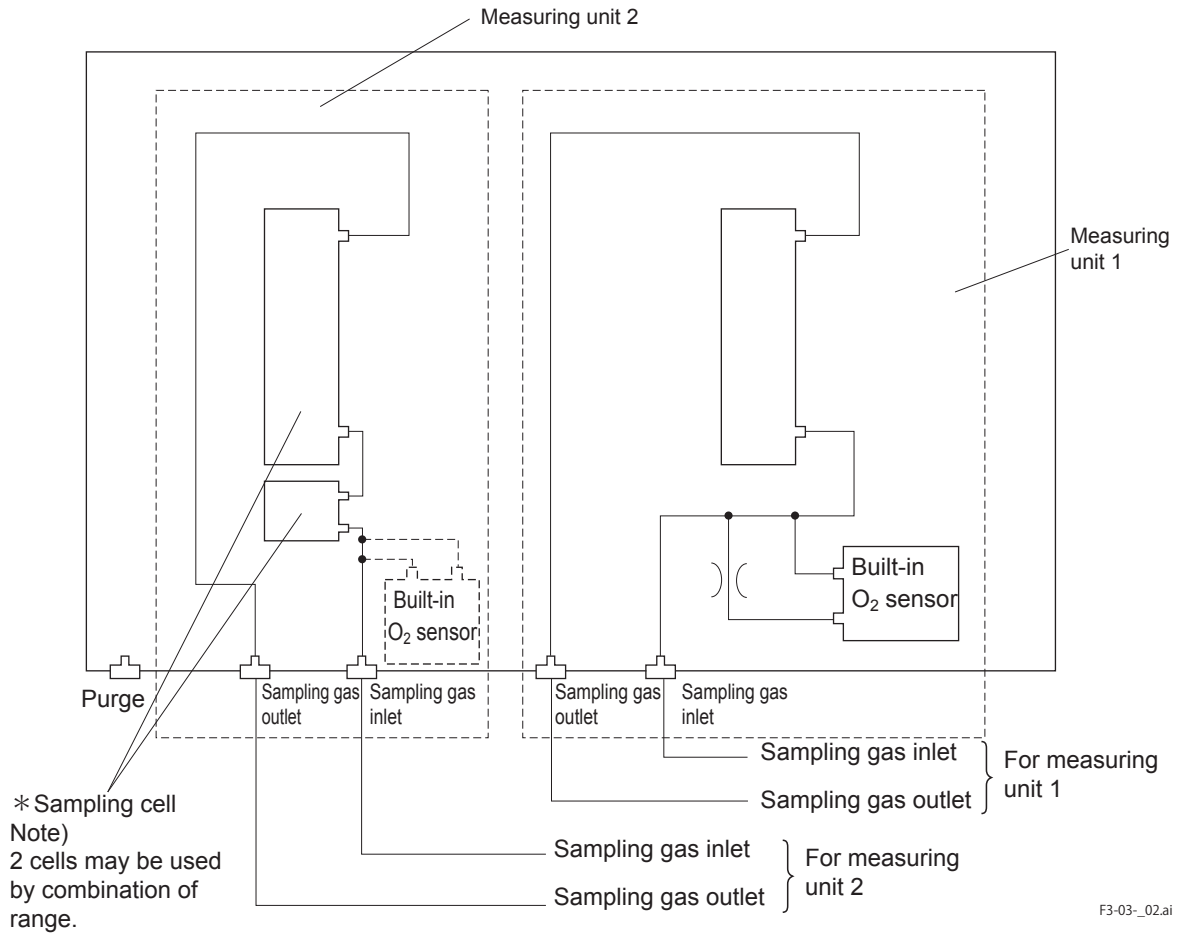

Correspondence of measured components and measuring units

Measuring components	Measuring unit 1	Measuring unit 2
1-component Analyzer for NO, SO ₂ , CO ₂ , CO and CH ₄	Each component	None
2-component Analyzer for NO-SO ₂ and CO ₂ -CO	NO-SO ₂ CO ₂ -CO	None
2-component Analyzer for NO-CO	NO	CO
3-component Analyzer for NO-SO ₂ -CO	NO-SO ₂	CO
4-component Analyzer for NO-SO ₂ -CO ₂ -CO	NO-SO ₂	CO ₂ -CO

Note) When there are two measuring units, the built-in O₂ sensor must be connected to the measuring unit 2.

Example of connecting each measuring unit

- One pair of gas inlet/outlet

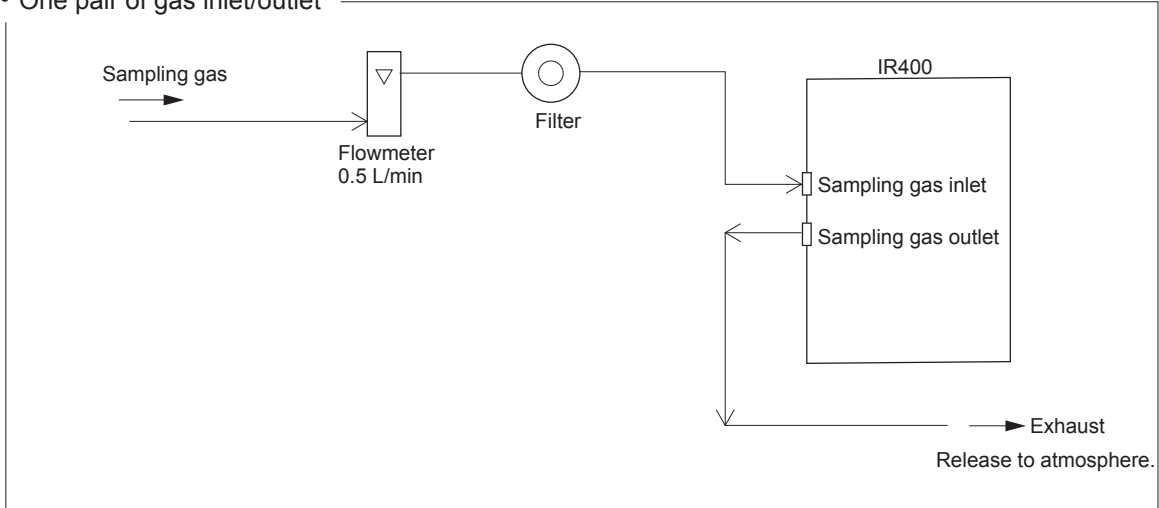

- Two pair of gas inlet/outlet - (1)

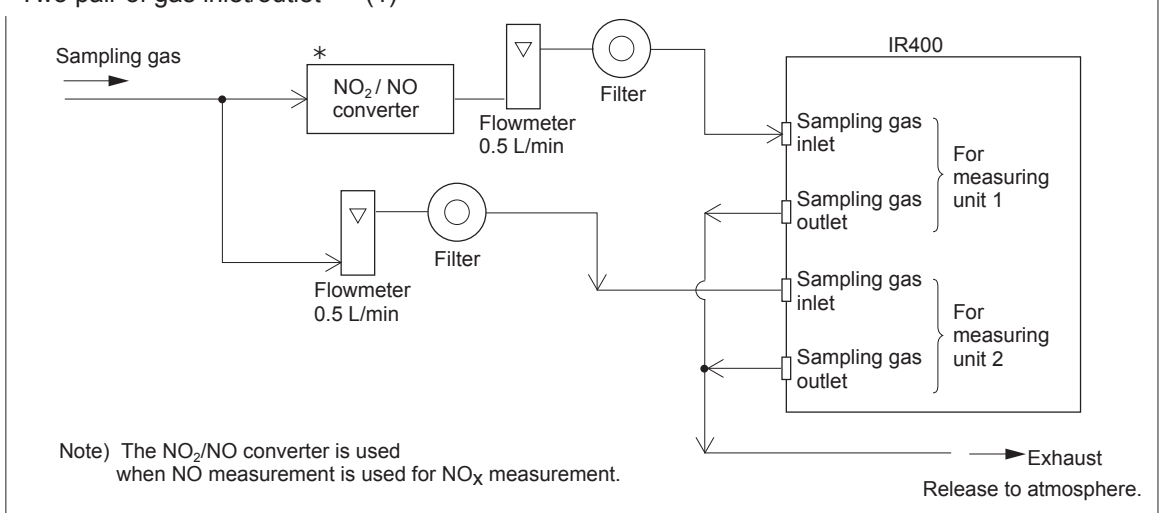

- Two pair of gas inlet/outlet - (2)

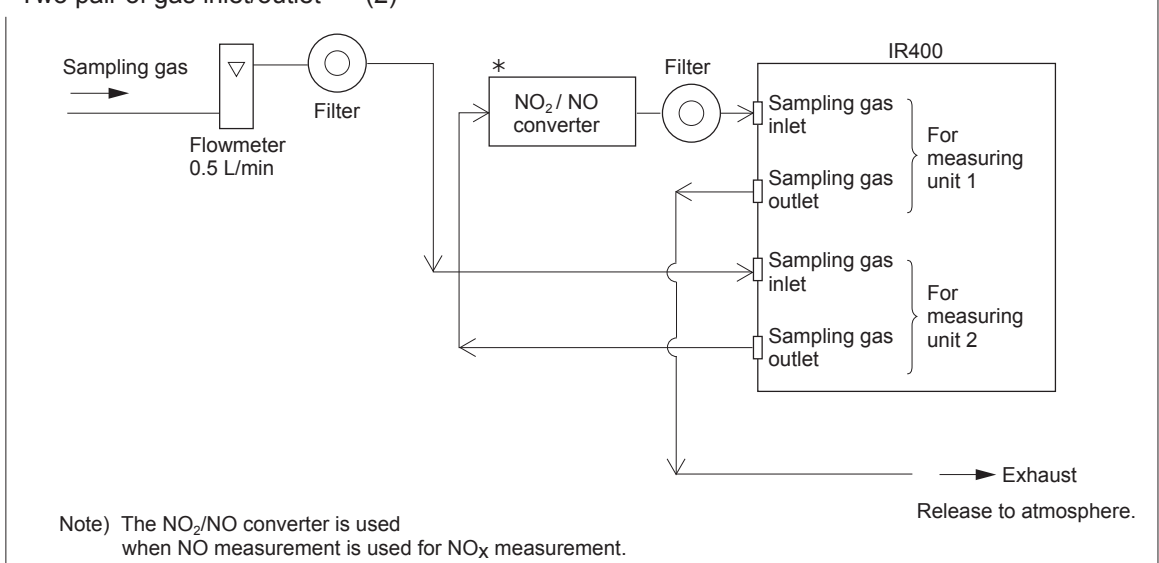

F3_3_3.ai

3.4 Sampling

3.4.1 Conditions of sampling gas

1. Dust contained in the sampling gas should be completely removed with a filter. For the final stage filter, use a filter that allows removing dust particles of 0.3 mm.
2. Dew point of sampling gas must be lower than the ambient temperature to avoid occurrence of drain in the gas analyzer. If vapor is contained in the sampling gas, dew point should be lowered to 0°C by using a dehumidifier.
3. If SO₃ mist is contained in the sampling gas, use a mist filter or cooler to remove SO₃ mist. Other mists should be removed by using a mist filter or cooler.
4. Corrosive gases such as Cl₂, F₂ and HCl, if they are contained in the sampling gas in considerable amounts, will shorten the life of instruments.
5. Temperature of sampling gas should be within 0 to 50°C. Provide a means that prevents entry of hot gas directly into the instrument.

3.4.2 Sampling gas flow

Flow of sampling gas should be 0.5 ± 0.2 L/min.

Avoid flow fluctuation during measurement.

Observe the flow reading by a flowmeter provided as shown in the example of the sampling system configuration (Item 3.4.7).

3.4.3 Preparation of standard gas

Routine calibration is required by standard gas for keeping this instrument under normal operation condition (once a week). Prepare a standard gas cylinder for zero calibration and span calibration.

	Analyzer without O ₂ measurement	Analyzer with built-in O ₂ sensor	Analyzer with external zirconia O ₂ sensor
Zero gas	N ₂ gas	N ₂ gas	Dry air or atmospheric air
Span gas other than for O ₂ measurement	Gas with concentration of 90% or more of full scale	Gas with concentration of 90% or more of full scale	Gas with concentration of 90% or more of full scale
Span gas for O ₂ measurement	_____	Gas with concentration of 90% or more of full scale or atmospheric air (21%)	1 to 2%O ₂

3.4.4 Reduction of moisture interference

NO and SO₂ measurement is subject to moisture interference.

As shown by the configuration example on the next page, provide a device for humidifying zero calibration gas, thus controlling the moisture content at a constant level (moisture content in sample gas should also be controlled here) in configuring a sampling system. That allows the same moisture content as in the case of measurement to be contained in zero gas for calibration.

3.4.5 Purging of instrument inside

The inside of instrument need not be purged generally except for the following cases.

1. A combustible gas component is contained in sample gas.
2. Corrosive gas is contained in the atmospheric air at the installation site.
3. The same gas as the sample gas component is contained in the atmospheric air at the installation site.

In such cases as above, the inside of analyzer should be purged with the air for instrumentation or N₂. Purging flow rate should be about 1 L/min.

If dust or mist is contained in purging gas, it should be eliminated completely in advance.

3.4.6 Pressure at sampling gas outlet

Pressure at the sampling gas outlet should be adjusted to atmospheric pressure.

3.4.7 Example configuration of gas sampling system

The following illustrates a typical system configuration for five component gas measurement for monitoring combustion exhaust gas from boiler, refuse incinerator, etc. Contact Yokogawa for system configuration matching the particular use or further information.

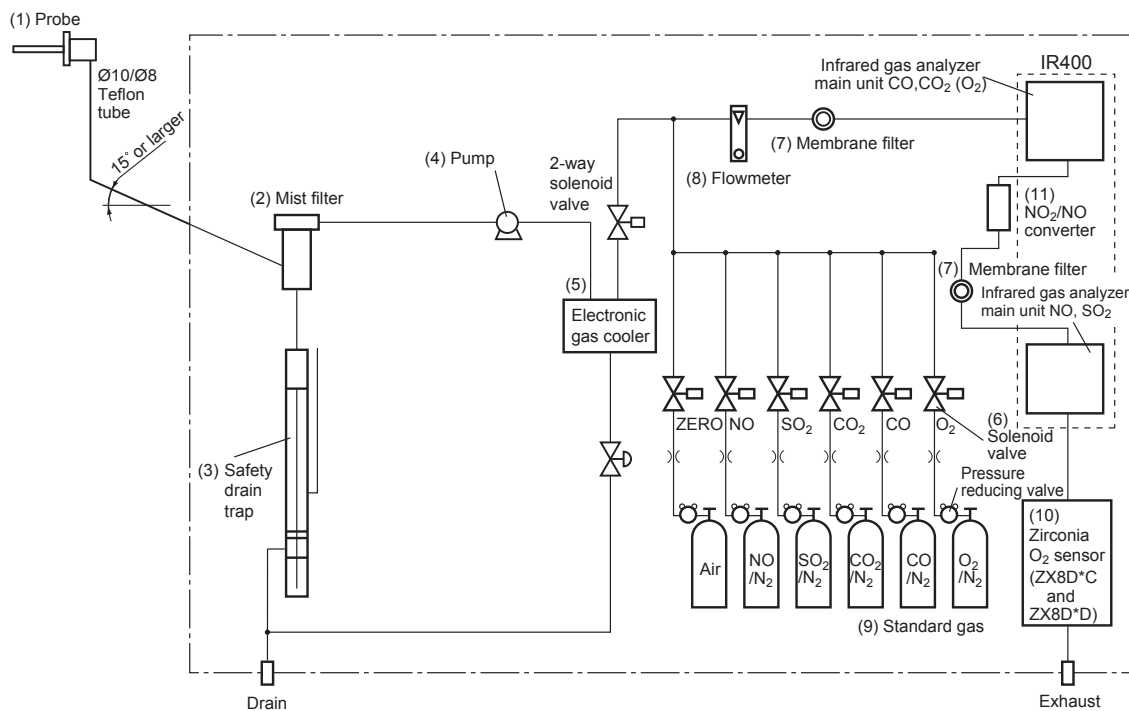

F3_4_7.ai

Name	Description	Name	Description
(1) Probe	Gas extractor with a heating type stainless steel filter of standard mesh 40 µm.	(8) Flowmeter	Adjusts and monitors the flow rate of sample gas.
(2) Mist filter	Removes drain, mist, and dust.	(9) Standard gas	Reference gas used for calibrating zero and span of the analyzer. Total 6 cylinders required for zero gas air, span gas NO, SO ₂ , CO, CO ₂ and O ₂ .
(3) Safety drain trap	The safety drain trap divided into two rooms for positive and negative pressure. It monitors and adjusts the sample gas pressure.		
(4) Pump	For aspiration of sample gas	(10) Zirconia O ₂ sensor	External zirconia oxygen sensor used for measuring the oxygen concentration in sample gas. (This is not necessary in case when O ₂ sensor is built-in.)
(5) Electronic gas cooler	Dries the moisture in sample gas to a dew point of approx. 2°C.	(11) NO ₂ / NO converter	Added to NOx analyzer. A special catalyst material for efficient conversion of NO ₂ gas to NO is used.
(6) Solenoid valve	Used for introducing calibration gas.		
(7) Membrane filter	PTFE filter used to eliminate fine dust particles and permit monitoring of dust adhering condition on the front panel of the gas analyzer.		

3.5 Wiring

3.5.1 Power inlet

The power inlet is provided at the rear panel. Connect supplied power cable to this power inlet.

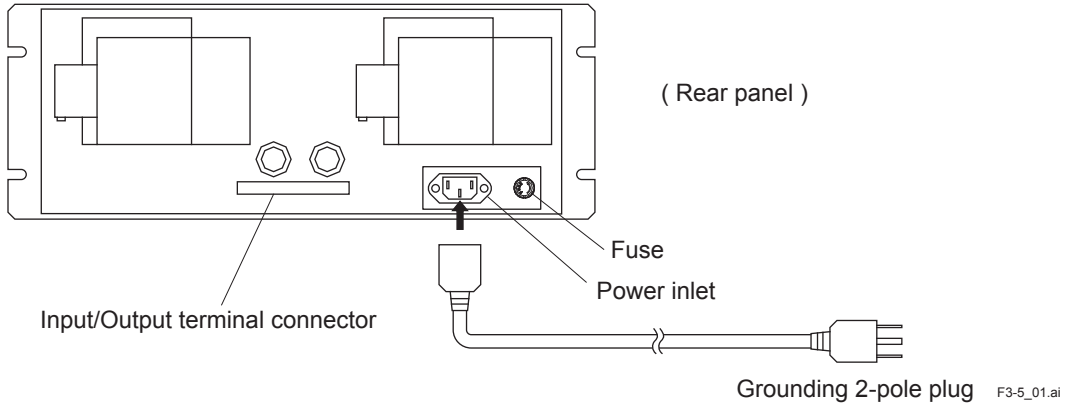

When noise source is in the vicinity

- Avoid installing this instrument near an electrical unit (high frequency furnace or electric welder) that generates much electrical noise. If using the instrument near such a noise generating unit is unavoidable, use a different power line to avoid noise.
- Mount a noise suppressor such as varistor or spark killer as shown at right figure to the noise generating unit when noise is generated from relays or solenoid valves. Mount the suppressor near the noise generating source, or it will have no effect.

Main unit power supply

Varistor or spark killer

Install (connect) near the source.

Noise generating source

F3_512.ai

3.5.2 Input/Output terminal module

This analyzer should be connected to the input/output terminal module by supplied exclusive cable. Plug this cable connector into the receptacle at the rear panel of the analyzer and the receptacle on the PC board of the input/output module.

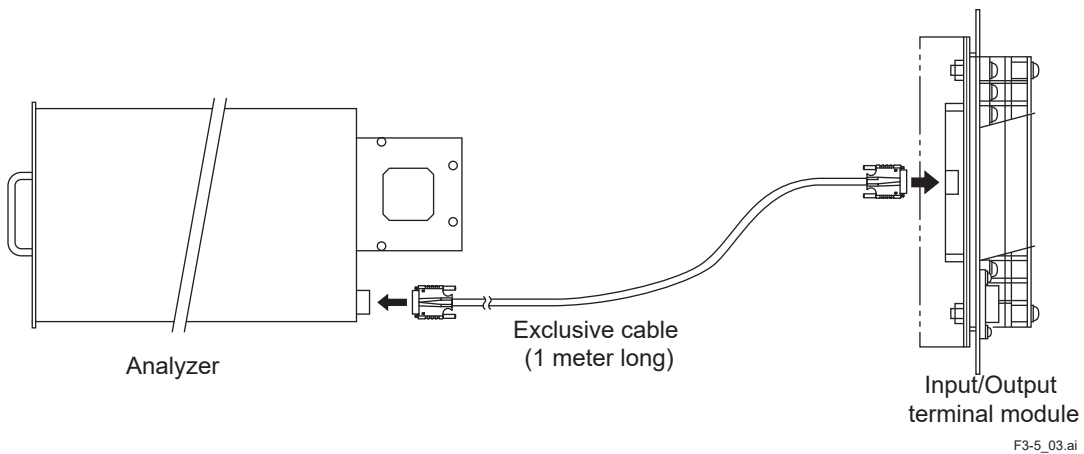

(1) Analog output signal (AO): Terminal block 1, 1 to 20, Terminal block 2, 3 to 6.

Output signal:	4 to 20 mA DC or 0 to 1 V DC (selected when ordering) Non-insulated output
Allowable load:	4 to 20 mA DC, 550 Ω or less 0 to 1 V DC, 100 k Ω or more

- Analog output is provided from each terminal corresponding to the channel displayed in the measurement screen.

CAUTION

All of analog output signals for the instrument are not isolated. It is recommended to isolate signals individually to prevent interference from unnecessary signals or to prevent external interference, especially when you lead the cable of more than 30 meters or to outdoor.

(2) O₂ sensor input: Terminal block 2, 1 to 2.

Input signal:	
External zirconia O ₂ analyzer:	Zirconia O ₂ sensor signal (ZX8D output)
External O ₂ analyzer:	0 to 1 V DC (DC input resistor of 1M Ω or more)

- It is used when the external zirconia O₂ analyzer or external O₂ analyzer is specified as order.
- To connect to the output of the external zirconia analyzer or external O₂ analyzer prepared separately.
- In case of an external O₂ analyzer, input a signal of 0 to 1 V DC with respect to O₂ full scale of the analyzer.
- In case of built-in O₂ analyzer, do not use the terminals.

CAUTION

O₂ sensor input is not isolated. It is recommended to isolate when an external O₂ analyzer is installed apart from this analyzer. Zirconia O₂ sensor (ZX8D) should be installed at a location that is as close to this instrument as possible.

(3) Contact input (DI): Terminal block 2, 1 to 20, Terminal block 3, 5 to 10.

- It is for a contact input at no voltage. An input is provided when switching to short circuit (on) or open (off).
- No voltage is applied to the terminals.

(4) Contact output (DO): Terminal block 3, 11 to 20, Terminal block 4 and Terminal block 5

- Contact rating: 250 V AC/2 A, load resistance
- An output is for a relay contact output. An output is provided when switching to conductive (on) or open (off).

CAUTION

Wiring of analog output signal, O₂ sensor input and contact input should be fixed separately from the wiring of power supply and contact output.

Note) To avoid the effect of noise generated from external units, be sure to ground the analyzer main unit. Keep conductivity between the I/O module mounting plate and the panel and connect the panel casing to the same ground as the analyzer.

(5) List of terminal blocks

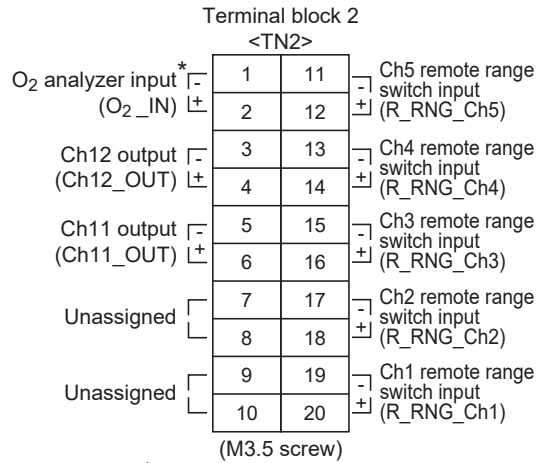
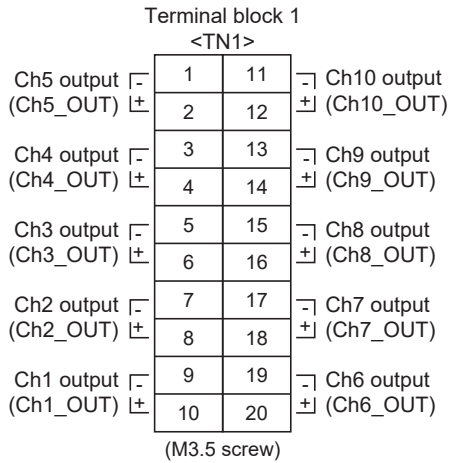

*For external O₂ analyzer input.

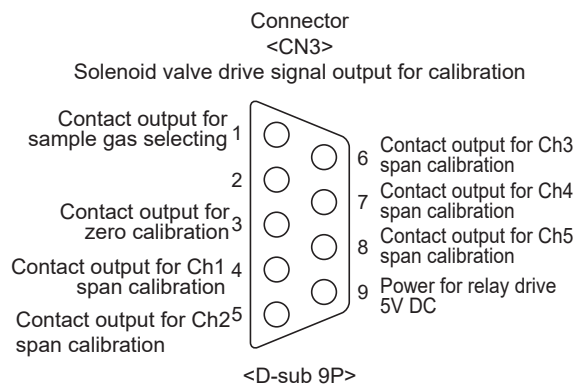
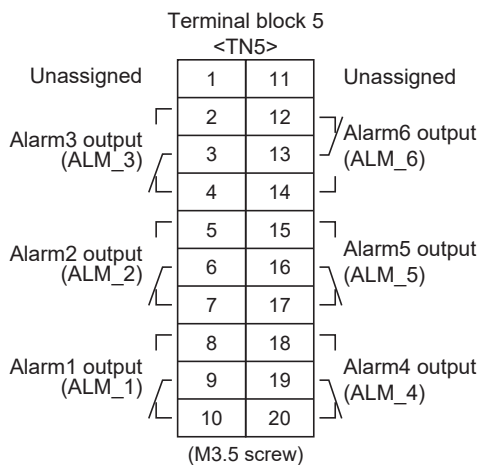
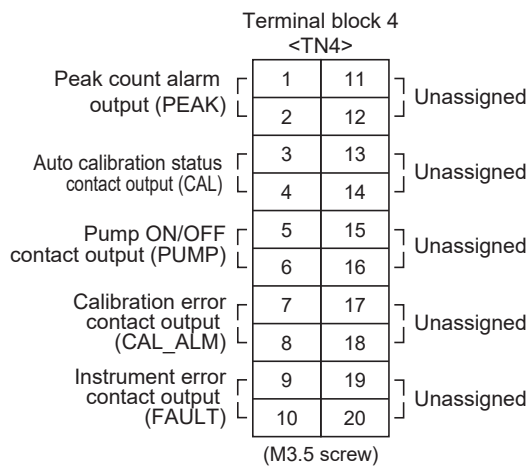
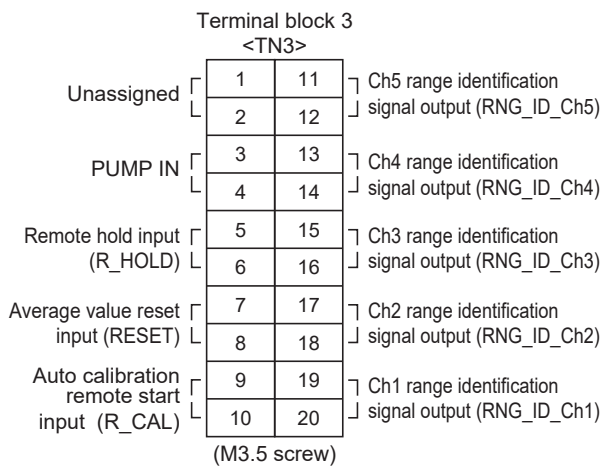

Note 1: Unassigned terminals are used for internal connection. So they should not be used as repeating terminals either.

(6) Description on terminal block

Terminal block 1
<TN1>

Ch5 output (Ch5_OUT)	⊖	1	11	⊖	Ch10 output (Ch10_OUT)
	⊕	2	12	⊕	
Ch4 output (Ch4_OUT)	⊖	3	13	⊖	Ch9 output (Ch9_OUT)
	⊕	4	14	⊕	
Ch3 output (Ch3_OUT)	⊖	5	15	⊖	Ch8 output (Ch8_OUT)
	⊕	6	16	⊕	
Ch2 output (Ch2_OUT)	⊖	7	17	⊖	Ch7 output (Ch7_OUT)
	⊕	8	18	⊕	
Ch1 output (Ch1_OUT)	⊖	9	19	⊖	Ch6 output (Ch6_OUT)
	⊕	10	20	⊕	

(M3.5 screw)

F3_5_TerminalB1.ai

Terminal block 2
<TN2>

Note 1 O ₂ sensor input (O ₂ _IN)	⊖	1	11	⊖	Ch5 remote range switch input (R_RNG_Ch5)
	⊕	2	12	⊕	
Ch12 output (Ch12_OUT)	⊖	3	13	⊖	Ch4 remote range switch input (R_RNG_Ch4)
	⊕	4	14	⊕	
Ch11 output (Ch11_OUT)	⊖	5	15	⊖	Ch3 remote range switch input (R_RNG_Ch3)
	⊕	6	16	⊕	
Unassigned	⊖	7	17	⊖	Ch2 remote range switch input (R_RNG_Ch2)
	⊕	8	18	⊕	
Unassigned	⊖	9	19	⊖	Ch1 remote range switch input (R_RNG_Ch1)
	⊕	10	20	⊕	

(M3.5 screw)

Note 1 : For external O₂ sensor input.

F3_5_TerminalB2.ai

Terminal block 1 <TN1>

Terminal block for analog output (non-isolated output)

Between 1–2: Ch5 output

Between 3–4: Ch4 output

Between 5–6: Ch3 output

Between 7–8: Ch2 output

Between 9–10: Ch1 output

Between 11–12: Ch10 output

Between 13–14: Ch9 output

Between 15–16: Ch8 output

Between 17–18: Ch7 output

Between 19–20: Ch6 output

Terminal block 2 <TN2>

Between 1–2: O₂ sensor input
(For input of (ZX8D) zirconia oxygen sensor or externally oxygen sensor. Must not be used unless external O₂ sensor is provided.)

Between 3–4: Ch12 output

Between 5–6: Ch11 output

Between 7–10: For internal connection. Must not be wired. (Must not be used as junction terminal).

Between 11–12: Ch5 remote range switch input

Between 13–14: Ch4 remote range switch input

Between 15–16: Ch3 remote range switch input

Between 17–18: Ch2 remote range switch input

Between 19–20: Ch1 remote range switch input

Action of remote range switch.

High range is selected when open.

Low range is selected when short-circuited.

For details of action, see “Item 5.1 Switch of range.”

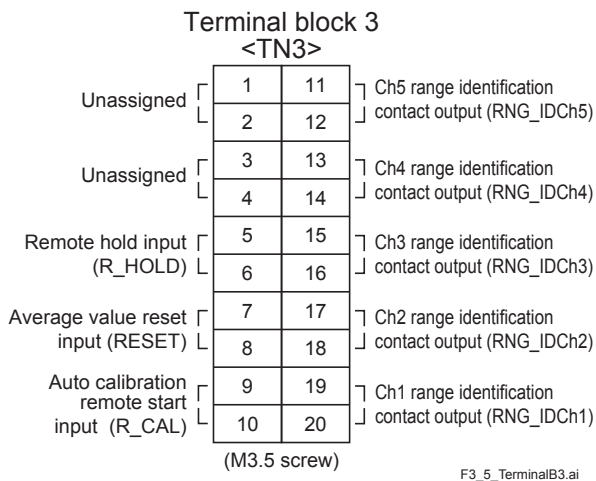

Terminal block 3 <TN3>

Between 1–4: For internal connection. Must not be wired. (Must not be used as junction terminal.)

Between 5–6: Remote hold input.

No hold when open. Output hold when short-circuited.
For details, refer to “Item 5.7 Parameter setting, Output Hold”.

Between 7–8: Average value reset input.

Short-circuiting the contact input (for at 1.5 sec. or more.) resets O₂ average and O₂ corrected average simultaneously. Opening it restarts the average value.
For details, refer to “Item 5.7 Parameter setting, Average Value Resetting”

Between 9–10: Automatic calibration remote start input.

After shorting for 1.5 sec. or more, automatic calibration is started by the opening input whether the automatic calibration setting is ON/OFF.
For details, refer to “Item 5.4 Setting of auto calibration”

Between 11–12: Ch5 range identification contact output

Between 13–14: Ch4 range identification contact output

Between 15–16: Ch3 range identification contact output

Between 17–18: Ch2 range identification contact output

Between 19–20: Ch1 range identification contact output

Action of range identification signal output is conductive at low and open at high range.

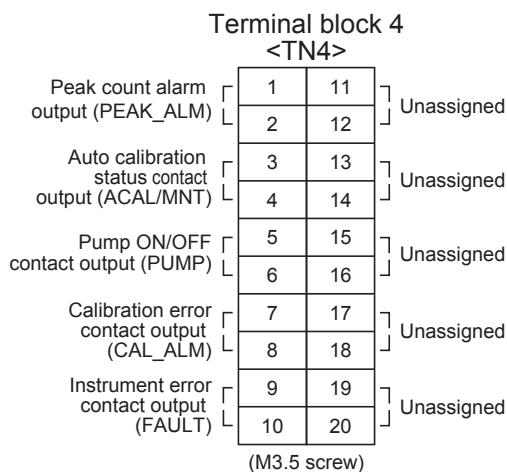

F3_5_TerminalB4.ai

Terminal block 4 <TN4>

- Between 1–2: Peak count alarm contact output
It is conductive when peak count exceeds the setting time. It remains open below the setting time. For setting and operation, refer to “Item 5.6 Peak alarm setting”.
- Between 3–4: Contact output of auto calibration status
When the auto calibration is carried out and remote hold is ON, it is conductive. Remains open otherwise.
- Between 5–6: Pump ON/OFF contact output
Used when turning ON/OFF the pump. It is open during auto and manual calibration status and conductive during measurement.
- Between 7–8: Calibration error contact output
It is conductive when an error occurs during zero calibration or span calibration. It is normally open.
- Between 9–10: It is conductive when an error occurs to the analyzer unit. It is normally open.
- Between 11–20 For internal connection, wiring is not allowed. (Do not use it as junction terminal).

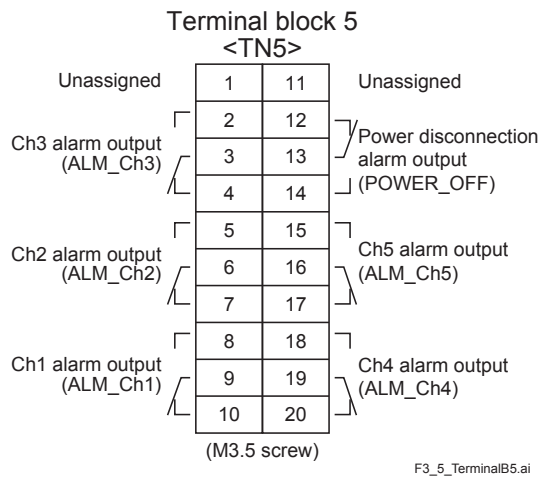

Terminal block 5 <TN5>

Between 2, 3 and 4:

Ch3 alarm output

When the output exceeds the set value, it is conductive between 2 and 3, and open between 3 and 4. Otherwise, it is open between 2 and 3 and conductive between 3 and 4.

Between 5, 6 and 7:

Ch2 alarm output

When the output exceeds the set value, it is conductive between 5 and 6, and open between 6 and 7. Otherwise, it is open between 5 and 6, and conductive between 6 and 7.

Between 8, 9 and 10:

Ch1 alarm output

When the output exceeds the set value, it is conductive between 8 and 9, and open between 9 and 10. Otherwise, it is open between 8 and 9.

Between 12, 13 and 14:

Analyzer unit power OFF output

When the analyzer unit is turned ON, it is conductive between 12 and 13, and open between 13 and 14. When the analyzer unit is turned OFF, it is open between 12 and 13, and conductive between 13 and 14.

Between 15, 16 and 17:

Ch5 alarm output

When the output exceeds the set value, it is conductive between 15 and 16, and open between 16 and 17. Otherwise, it is open between 15 and 16, and conductive between 16 and 17.

Between 18, 19 and 20:

Ch4 alarm output

When the output exceeds the set value, it is conductive between 18 and 19, and open between 19 and 20. Otherwise, it is open between 18 and 19, and conductive between 19 and 20. For detailed action of the alarm contact, refer to "Item 5.3 Alarm setting".

Connector <CN3>

Solenoid valve drive signal output for calibration

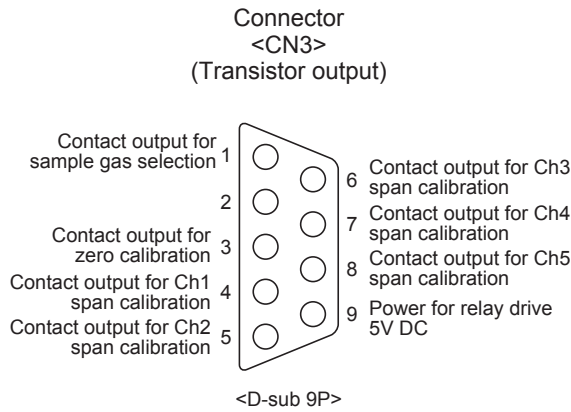

F3_5_CN3.ai

Connector <CN3> provides outputs in combination with calibration action during auto calibration and manual calibration.

An output is from a transistor (ratings: 5 V/50 mA).

A transistor is turned ON before starting each calibration.

Sample selection output is ON during measurement and OFF during calibration.

If calibration is not performed, the other transistors are OFF.

In case of auto calibration, sequential output is ON/OFF according to the setting.

Refer to "Item 5.4 Setting of auto calibration".

Note) No. 9 pin is for solenoid valve ON/OFF relay drive power (5 V DC/0.5 A, max).
Use No. 9 with reference to the diagram.

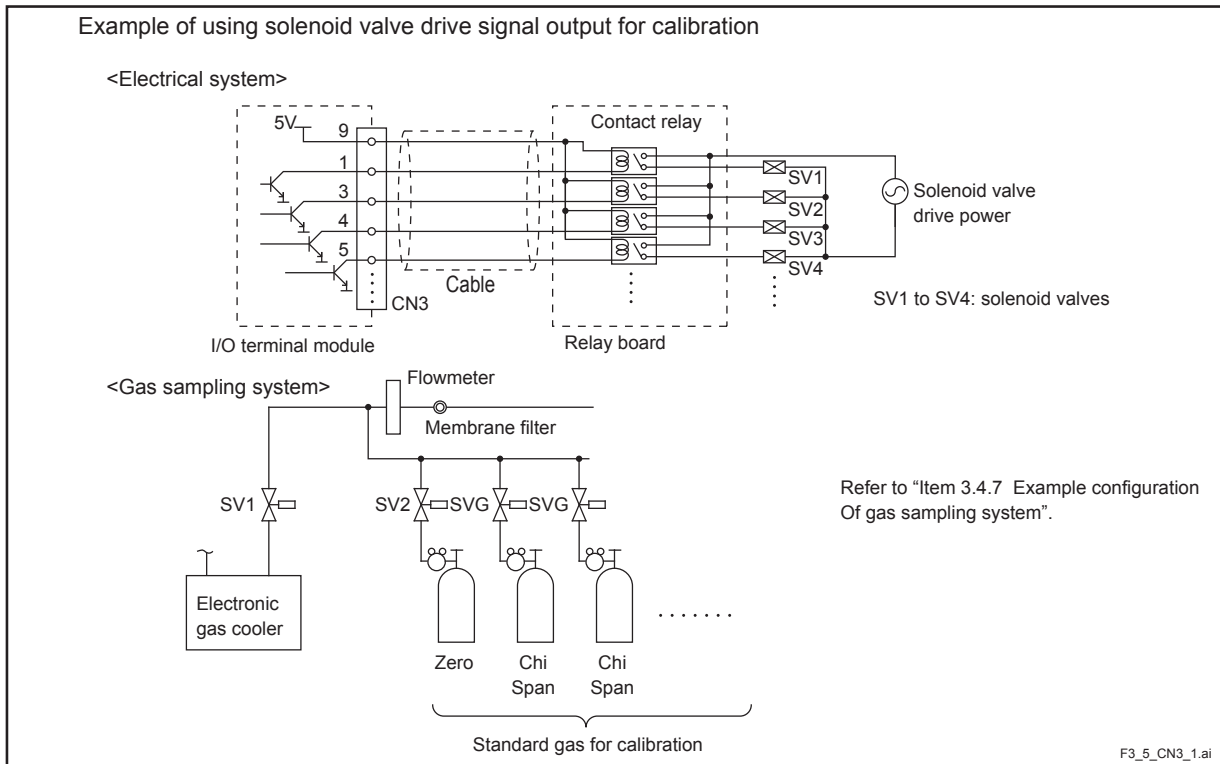

Relay board and exclusive cable (D-sub 9th straight cable: 1.5 meters) are available on request.

(7) Timing of solenoid valve drive signal for calibration

1. Manual calibration (see "Item 5.9 Calibration".)

• Zero calibration

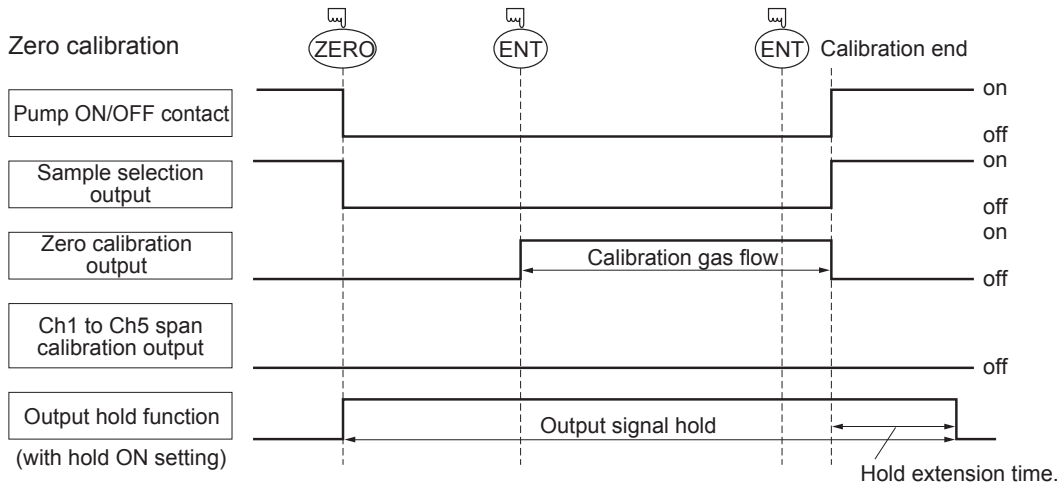

• Span calibration

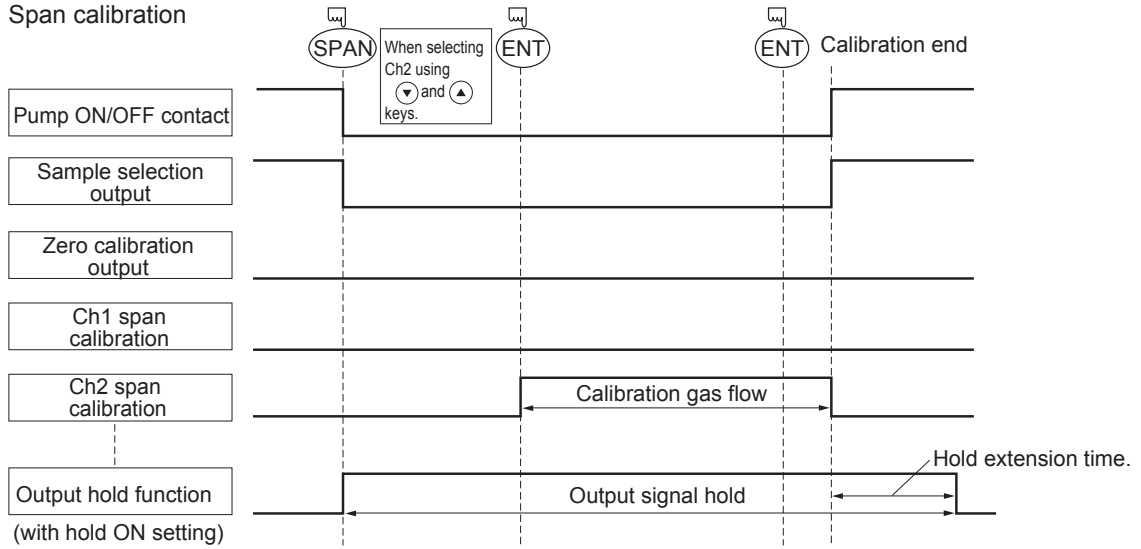

Note) The hold extension time depends on the gas flow time of the automatic calibration settings.

F3_5_calibration.ai

2. Automatic calibration (example shown in Item 5.4.1, Automatic calibration settings)

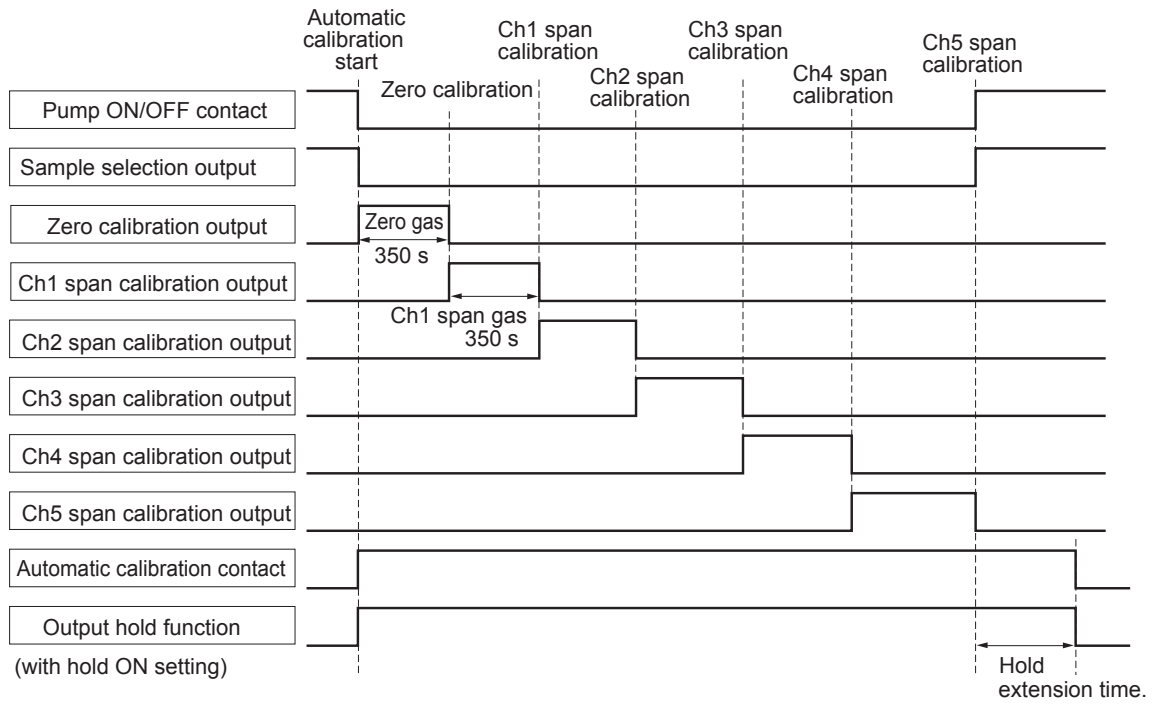

F3_5_auto-calibration.ai

4. OPERATION

Tube and wiring check

- Double-check if tubes of the gas sampling and exhaust ports are correctly connected.
- Double-check for proper wiring.

4.1 Warm-up operation and regular operation

(1) Operation procedure

- 1) Turn ON the power switch on the front panel of the analyzer unit.
The measurement screen appears on the front display panel in 1 or 2 seconds.
- 2) Wait for about 4 hours until the instrument is warmed up.
About 4 hours are required until the instrument allows accurate measurement.

Note) When in warm-up, the concentration reading may be beyond.

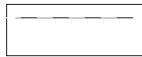

upper limit of range or



lower limit of range.

But, it is not an error.

- 3) Setting of various set values
Perform the various settings according to “Chapter 6. Setting and Calibration”.
- 4) Zero calibration and span calibration
Perform zero calibration and span calibration after warm-up operation.
Refer to “Chapter 6.9. Calibration”.
- 5) Introduction and measurement of measuring gas
Introduce the measuring gas into the analyzer unit before starting measurement.

4.2 Name and description of operation panel

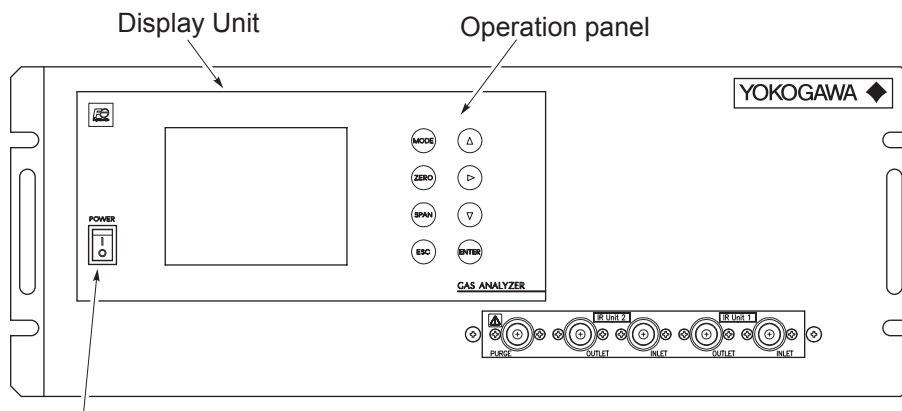

Power switch

- Display unit : The measurement screen and the setting items are displayed.
- Operation panel : The configuration is as shown below.

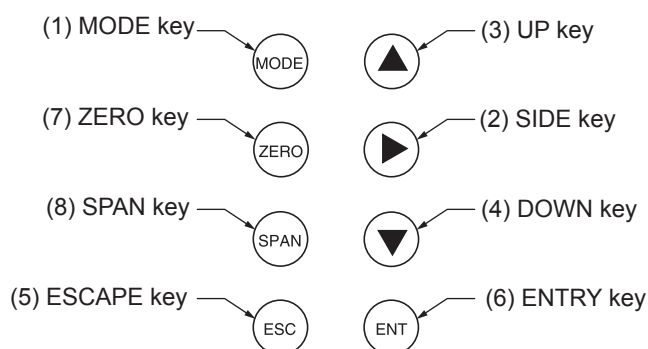
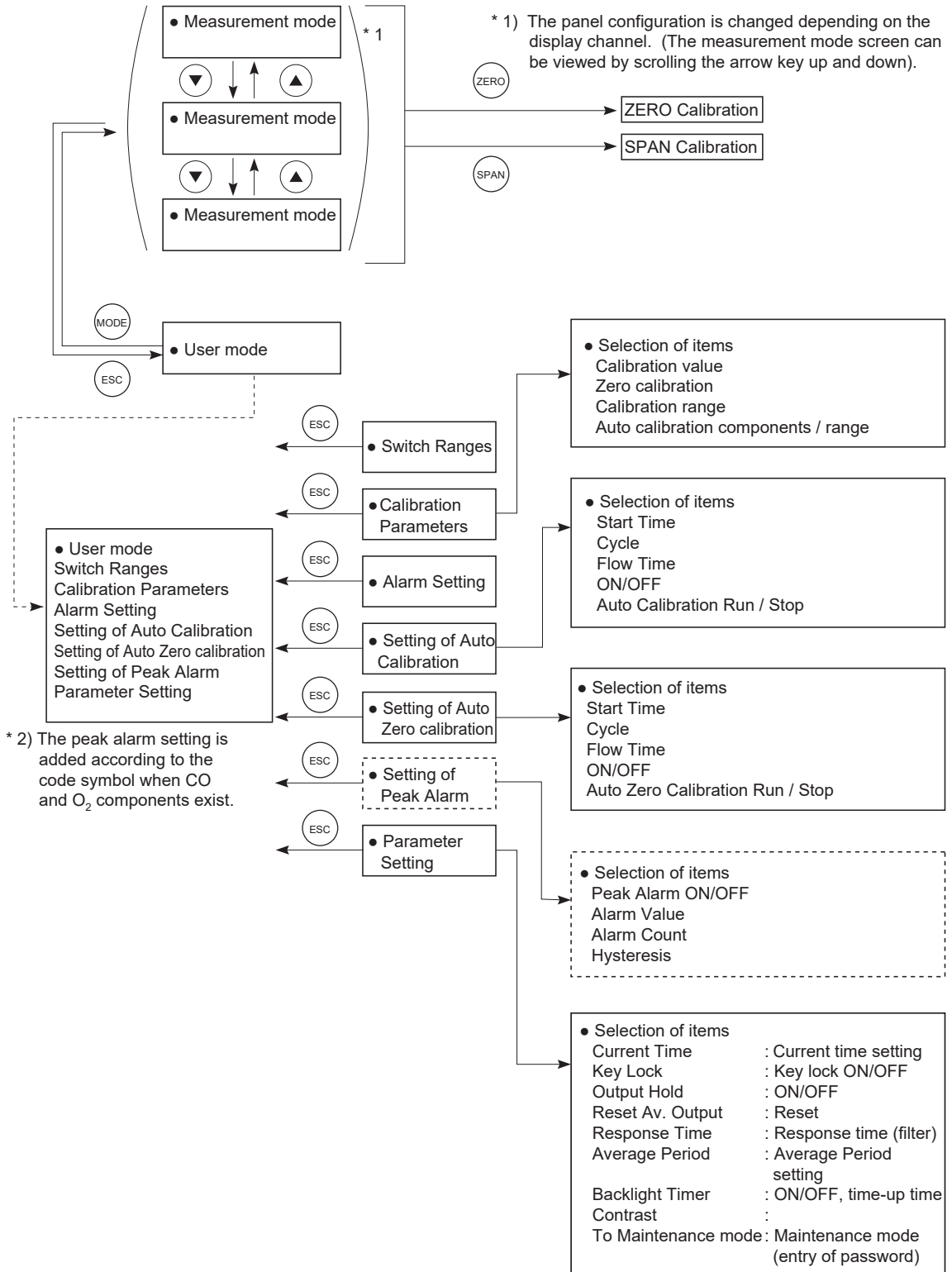

Fig. 4-1

Name	Description	Name	Description
(1) MODE key	Used to switch the mode.	(5) ESCAPE key	Used to return to a previous screen or cancel the setting midway.
(2) SIDE key	Used to change the selected item (by moving the cursor) and numeral digit.	(6) ENTRY key	Used for confirmation of selected items or values, and for execution of calibration.
(3) UP key	Used to change the selected item (by moving the cursor) and to increase numeral value.	(7) ZERO key	Used for zero calibration.
(4) DOWN key	Used to change the selected item (by moving the cursor) and to decrease numeral value.	(8) SPAN key	Used for span calibration.

4.3 Overview of display and operation panels



F5_2.ai

Fig. 4-2

4.4 Outline of display screen

(1) Measurement mode screen (appears when the power is turned ON)

The measurement screen depends on the number of components. The following screen configuration as shown as an example is for NO, SO₂, CO₂, CO and O₂ (output: 12 channel).

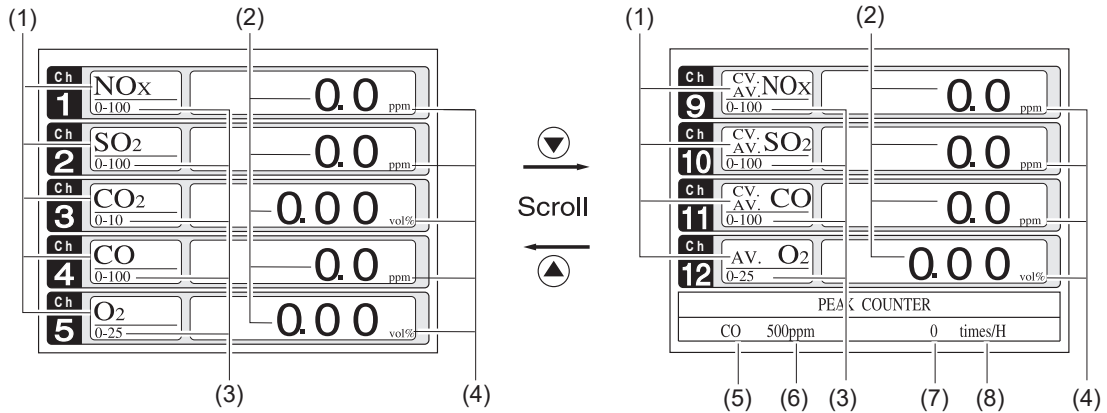

* corrected instantaneous value CV.
 ** corrected average value.....CV.
 AV.

F5_3.ai

Fig. 4-3 Name and function of measurement mode screen

* For outputs of more than 5 channels, scroll the arrow key or to view.

No.	Name	Function	No.	Name	Function
(1)	Component display	Displays component of instantaneous value, corrected instantaneous value, corrected average value, etc.	(5)	Peak alarm component display	Displays peak alarm component.
(2)	Concentration display	Displays measured value of concentration.	(6)	Peak alarm concentration display	Displays peak alarm concentration display. (Upper limit value)
(3)	Range display	Displays range values.	(7)	Peak alarm times	Displays the alarm times exceeding the peak value.
(4)	Unit display	Displays unit with ppm and vol%.	(8)	Peak alarm unit display	Displays units of peak alarm with times/H.

●Instantaneous value and concentration value:

The concentration display of Ch (component) where sampling components such as “CO₂”, “CO” or “O₂ are displayed in the component display, indicates current concentration values of the measured components contained in gas that is now under measurement.

● O₂ correction concentration values:

Ch components where “cv**” is displayed as “cv CO” in the component display are calculated from the following equation, by setting sampling components, O₂ instantaneous/concentration values and O₂ correction reference value (see item 6.8).

$$\text{Correction output} = \frac{21 - O_n}{21 - O_s} \times C_s$$

On: The value of the O₂ correction reference value (Value set by application)

Os: Oxygen concentration (%)

Cs: Concentration of relevant measured component.

Note that Os does not exceed the O₂ limit value

The converted sampling components are NOx, SO₂ and CO only.

● O₂ correction concentration average value:

In the Ch (component) and O₂ average value where “^{CV}/_{AV} ** ” is displayed as “^{CV}/_{AV} CO” in the component display, a value obtained by averaging O₂ correction concentration value or O₂ average value in a fixed time is output every 30 seconds.

Averaging time can be changed between 1 minute and 59 minutes or 1 hour and 4 hours according to the average time settings (See 5.7, Parameter setting).

(The set time is displayed as “1 h”, for instance, in the range display.)

* The measurement ranges of O₂ correction concentration value and O₂ correction concentration average value are the same as that of the measuring components. Also, the measurement range of O₂ average value is the same as that of O₂.

(2) Setting/selection screen

The setting/selection screen is configured as shown below:

- In the status display area, the current status is displayed.
- In the message display area, messages associated with operation are displayed.
- In the setting item and selection item display area, items or values to be set are displayed, as required. To work on the area, move the cursor to any item by using ▲, ▼ and ► keys.

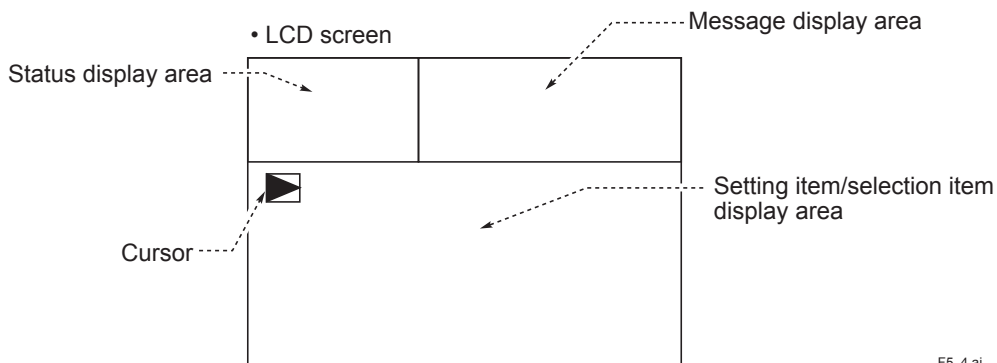

F5_4.ai

Fig. 4-4

Measurable component	Code symbol		Output corresponding to channels											
	O ₂ analyzer	O ₂ correction	Ch1	Ch2	Ch3	Ch4	Ch5	Ch6	Ch7	Ch8	Ch9	Ch10	Ch11	Ch12
-A	N	O ₂ correction	NO											
-B	N	Not specified	SO ₂											
-C	N	Not specified	CO ₂											
-D	N	Not specified	CO											
-F	N	Not specified	CH ₄											
-G	N	Not specified	NO	SO ₂										
-H	N	Not specified	NO	CO										
-J	N	Not specified	CO ₂	CO										
-K	N	Not specified	NO	SO ₂	CO									
-L	N	Not specified	NO	SO ₂	CO ₂	CO								
-A	1, 2, 3	/K	NO _X	O ₂	Correct NO _X	Correct NO _X av.	O ₂ av.							
-B	1, 2, 3	/K	SO ₂	O ₂	Correct SO ₂	Correct SO ₂ av.	O ₂ av.							
-D	1, 2, 3	/K	CO	O ₂	Correct CO	Correct CO av.	O ₂ av.							
-F	1, 2, 3	/K	CH ₄	O ₂	O ₂ av.									
-G	1, 2, 3	/K	NO _X	SO ₂	O ₂	Correct NO _X av.	Correct SO ₂	Correct NO _X av.	Correct SO ₂ av.	O ₂ av.				
-H	1, 2, 3	/K	NO _X	CO	O ₂	Correct NO _X	Correct CO	Correct NO _X av.	Correct CO av.	O ₂ av.				
-J	1, 2, 3	/K	CO ₂	CO	O ₂	Correct CO av.	Correct CO av.	O ₂ av.						
-K	1, 2, 3	/K	NO _X	SO ₂	CO	O ₂	Correct NO _X	Correct SO ₂	Correct CO	Correct NO _X av.	Correct SO ₂ av.	Correct CO av.	O ₂ av.	
-L	1, 2, 3	/K	NO _X	SO ₂	CO ₂	CO	O ₂	Correct NO _X	Correct SO ₂	Correct CO	Correct NO _X av.	Correct SO ₂ av.	Correct CO av.	O ₂ av.
-D	1, 2, 3	except /K	CO	O ₂										
-H	1, 2, 3	except /K	NO	CO	O ₂									
-J	1, 2, 3	except /K	CO ₂	CO	O ₂									
-K	1, 2, 3	except /K	NO	SO ₂	CO	O ₂								
-L	1, 2, 3	except /K	NO	SO ₂	CO ₂	CO	O ₂							

T08.ai

(Note)  : As for the NO meter within this range, the display on the indicator become NO_X.
 The peak count alarm becomes a contact output.
 The "correct" means O₂ correction.
 The "av." means average value.

4.5 General operation

• Measurement mode

The measurement mode can be displayed up to 5 channels in a single screen. If 5 channels or more are to be displayed in a single screen, press the or key to scroll the channel one by one.

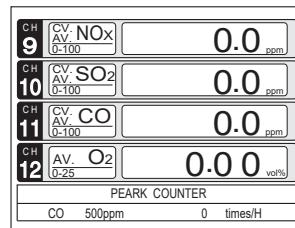
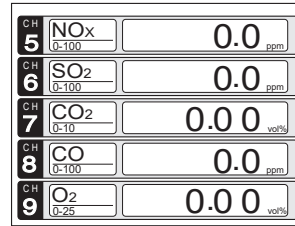

ZERO

⇒ Zero calibration
See 6.9.1.

⇒ Span calibration
See 6.9.2.

SPAN

MODE

ESC

• User mode displays;

- Switch Ranges
- Calibration Parameters
- Alarm Setting
- Setting of Auto Calibration
- Setting of Auto Zero Calibration
- Setting of Peak Alarm
- Parameter Setting.

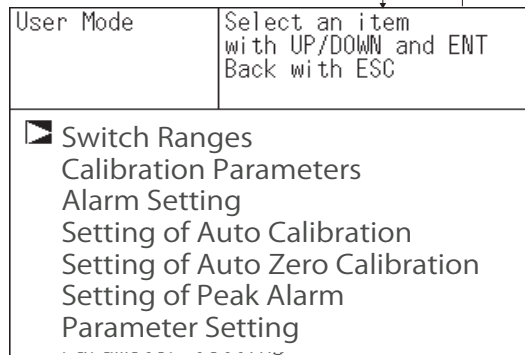

For the setting contents, refer to "Chapter 5. Setting and calibration".

F5_4G-Ope.al

5. SETTING AND CALIBRATION

5.1 Switch of range

5.1.1 Setting of range switch mode

Set the range switch mode as follows.

- (1) Press the **(MODE)** key in measurement mode to display the User mode screen.
- (2) Move the cursor to "Switch Ranges" and press the **(ENT)** key.

↓ **(MODE)**

User Mode	Select an item with UP/DOWN and ENT Back with ESC
▣ Switch Ranges Calibration Parameters Alarm Setting Setting of Auto Calibration Setting of Auto Zero Calibration Setting of Peak Alarm Parameter Setting	

- (3) The "Channel Selection" screen appears. Move the **▣** cursor by pressing the **(▲)** or the **(▼)** key on the channel selection screen that appears, and select Ch (component).

↓ **(ENT)**

Switch Range	Select Ch No. with UP / DOWN and ENT Back with ESC
▣ Ch1 NO _x MR Ch2 SO ₂ AR Ch3 CO ₂ RR Ch4 CO MR Ch5 O ₂ MR	▶ Range1 0-100 ppm Range2 0-2000 ppm ▶ Range1 0-100 ppm Range2 0-2000 ppm ▶ Range1 0-10 vol% Range2 0-20 vol% ▶ Range1 0-100 ppm Range2 0-2000 ppm ▶ Range1 0-10 vol% Range2 0-25 vol%

- (4) Then press the **(ENT)** key.

- (5) Selected range switch mode is highlighted. Press the **(▲)** or the **(▼)** key to select a desired switch mode.

Description of setting

MR: Select a desired range on this screen.
 RR: Select a desired range according to the remote range switch contact input.
 AR: Automatically switched from Range 1 to Range 2 when the measured concentration exceeds 90% of Range 1. Automatically switched from Range 2 to Range 1 when the measured concentration becomes smaller than 80% of Range 1.

* Operation set for each Ch only can be performed.

↓ **(▼)** **(▲)** **(ENT)**

Switch Range	Select method of Switch ranges with UP / DOWN and ENT Back with ESC
Ch1 NO _x MR Ch2 SO ₂ AR Ch3 CO ₂ RR Ch4 CO MR Ch5 O ₂ MR	▶ Range1 0-100 ppm Range2 0-2000 ppm ▶ Range1 0-100 ppm Range2 0-2000 ppm ▶ Range1 0-10 vol% Range2 0-20 vol% ▶ Range1 0-100 ppm Range2 0-2000 ppm ▶ Range1 0-10 vol% Range2 0-25 vol%

↓ **(▼)** **(▲)** **(ENT)**

Range switch or previous screen

- (6) Then press the **(ENT)** key to confirm the selection.
 If "MR" is selected, the cursor moves to "Range Switch."

F6_1_1note.ai

F6_1_1.ai



5.1.2 Manual range switch

The range of the measured component can be switched manually as follows.

- (1) Select "MR" as range switch mode, and then press the  key.

Switch Range		Select method of Switch ranges with UP / DOWN and ENT Back with ESC	
Ch1 NO _x	MR	▶ Range1 0-100 ppm	Range2 0-2000 ppm
Ch2 SO ₂	AR	▶ Range1 0-100 ppm	Range2 0-2000 ppm
Ch3 CO ₂	RR	▶ Range1 0-10 vol %	Range2 0-20 vol %
Ch4 CO	MR	▶ Range1 0-100 ppm	Range2 0-2000 ppm
Ch5 O ₂	MR	▶ Range1 0-10 vol %	Range2 0-25 vol %



- (2) Move the highlight of the cursor to range selection, and then select a desired range by pressing the  or the  key. (The mark indicates the currently selected range.)
- (3) Then press the  key, and the measurement is carried out in the selected range.

Switch Range		Select range with UP/DOWN and ENT Back with ESC	
Ch1 NO _x	MR	▣ Range1 0-100 ppm	Range2 0-2000 ppm
Ch2 SO ₂	AR	▶ Range1 0-100 ppm	▶ Range2 0-2000 ppm
Ch3 CO ₂	RR	▶ Range1 0-10 vol %	▶ Range2 0-20 vol %
Ch4 CO	MR	▶ Range1 0-100 ppm	▶ Range2 0-2000 ppm
Ch5 O ₂	MR	▶ Range1 0-10 vol %	▶ Range2 0-25 vol %

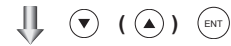

End of Range Switch

F6_1_2.ai

Note) If "RR" or "AR" is selected as range switch mode, this operation cannot be performed.
The range for O₂ correction value, O₂ correction average value, and O₂ average value is automatically switched if corresponding instantaneous value range is switched.

To close the setting

Press the  key to end the setting of range switch mode or range switch operation or stop the operation in the middle, and the setting operation is made invalid and the previous screen appears.

F6_1_2note.ai

Range identification contact operation

The range identification contact output corresponding to each Ch (component) is conductive when Range 1 is selected, and open when Range 2 is selected, which is applicable to any of the range switch mode selected.

Note that even if the range is switched during the hold of measurement value by remote hold contact input or the hold of measurement value at the time of calibration, the range identification contact output maintains the contact state immediately before the hold. After stop of the hold, the contact state of the current range is resumed.

F6_1_2note2.ai

5.2 Calibration setting

This mode is used to set calibration concentration and actions. The calibration setting involves calibration concentration, zero calibration, calibration range and auto calibration component.

5.2.1 Setting of calibration concentration

It allows you to set concentrations of the standard gas (zero and span) of each channel used for calibration.

(1) During measurement, press the **MODE** key to display the User Mode.

(2) Point the cursor to "Calibration Parameters" by pressing the **▲** or **▼** key. Press the **ENT** key.

(3) In the "Calibration Parameters" screen that appears, point the cursor to "Calibration Value" by pressing the **▲** or **▼** key. Press the **ENT** key.

(4) In the "Calibration Concentration Ch Selection" screen that appears, point the cursor to Ch you want to set by using the **▲** or **▼** key. Press the **ENT** key.

↓ **MODE**

User Mode	Select an item with UP/DOWN and ENT Back with ESC
Switch Ranges <input checked="" type="checkbox"/> Calibration Parameters Alarm Setting Setting of Auto Calibration Setting of Auto Zero Calibration Setting of Peak Alarm Parameter Setting	

↓ **▼** (**▲**) **ENT**

Cal. Parameters	Select an item with UP/DOWN and ENT Back with ESC
<input checked="" type="checkbox"/> Calibration Value About Zero Calibration About Calibration Range Auto Calibration Components / Range	

↓ **▼** (**▲**) **ENT**

Cal. Settings	Select Ch No. for setting calibration value		
Cal. Value			
CH	RANGE	ZERO	SPAN
<input checked="" type="checkbox"/> Ch1	0-100ppm	+0000.0	0100.0
NO _x	0-2000ppm	+00000	02000
Ch2	0-100ppm	+0000.0	0100.0
SO ₂	0-2000ppm	+00000	02000
Ch3	0-10vol%	+000.00	010.00
CO ₂	0-20vol%	+000.00	020.00
Ch4	0-100ppm	+0000.0	0100.0
CO	0-2000ppm	+00000	02000
Ch5	0-10vol%	21.00	01.00
O ₂	0-25vol%	21.00	01.00

↓ **▼** (**▲**) **ENT**

FB_2_1#

- (5) In the “Calibration Concentration Selection” screen that appears, select any concentration item you want to set by pressing the ▲, ▼ key. Then press the ENT key, and the selected value is highlighted.

Cal. Settings Cal. Value		Select setting value	
CH	RANGE	ZERO	SPAN
Ch1	0-100ppm	+0000.0	0100.0
NO _x	0-2000ppm	+00000	02000
Ch2	0-100ppm	+0000.0	0100.0
SO ₂	0-2000ppm	+00000	02000
Ch3	0-10vol%	+000.00	010.00
CO ₂	0-20vol%	+000.00	020.00
Ch4	0-100ppm	+0000.0	0100.0
CO	0-2000ppm	+00000	02000
Ch5	0-10vol%	21.00	01.00
O ₂	0-25vol%	21.00	01.00



- (6) In the “Calibration Concentration Value Setting” screen that appears, enter calibration gas concentration values (zero and span). For value entry, press the ▲ or ▼ key, and a 1-digit value increases or decreases. By pressing the ►, the digit moves. After setting, save the entry by pressing the ENT key. The saved value becomes valid from the next calibration process.

Cursor for setting value

Cal. Settings Cal. Value		Set calibration value	
CH	RANGE	ZERO	SPAN
Ch1	0-100ppm	+0000.0	0100.0
NO _x	0-2000ppm	+00000	02000
Ch2	0-100ppm	+0000.0	0100.0
SO ₂	0-2000ppm	+00000	02000
Ch3	0-10vol%	+000.00	010.00
CO ₂	0-20vol%	+000.00	020.00
Ch4	0-100ppm	+0000.0	0100.0
CO	0-2000ppm	+00000	02000
Ch5	0-10vol%	21.00	01.00
O ₂	0-25vol%	21.00	01.00



Note) Enter settings that correspond to each range.
If zirconia type is used as O₂ sensor, select 21.00 for the field of Zero (when air is used), and select the concentration listed on the cylinder if the air contained in a cylinder is used.

**End of Calibration
Concentration Setting**

FB.2.1.1#

To close the setting
To close the calibration concentration value setting process or cancel this mode midway, press the ESC key. A previous screen will return.

F6_2_1note.ai

Setting range of value

NO_x, SO₂, CO₂, CO, CH₄, external O₂ measurement and built-in paramagnetic O₂ sensor

Span gas: 1 to 105% of full scale (Full scale (FS) is the same as each range value.)





External Zirconia O₂ measurement

Zero gas: 5 to 25 vol%
Span gas: 0.01 to 5 vol%

The setting cannot be performed beyond the range.



5.2.2 Setting of manual zero calibration





When zero calibration is made manually, set either all measurement components should be calibrated simultaneously or each component should be calibrated while selecting one by one.

- (1) During measurement, press the  key to display the User Mode.
- (2) Point the cursor to "Calibration Parameters" by pressing the  or  key. Press the  key.



↓ 





User Mode	Select an item with UP/DOWN and ENT Back with ESC
Switch Ranges <input checked="" type="checkbox"/> Calibration Parameters Alarm Setting Setting of Auto Calibration Setting of Auto Zero Calibration Setting of Peak Alarm Parameter Setting	

- (3) In the "Calibration Parameters" screen that appears, point the cursor to "About ZERO Calibration" by pressing the  or  key. Press the  key.

↓   () 

Cal. Parameters	Select an item with UP/DOWN and ENT Back with ESC
Calibration Value <input checked="" type="checkbox"/> About Zero Calibration About Calibration Range Auto Calibration Components / Range	

- (4) In the "Manual ZERO Calibration Ch Selection" screen that appears, point the cursor to Ch (component) you want to set by using the  or  key. Press the  key.

↓   () 

Cal. Settings ZERO Cal.	Select Ch No.
<input checked="" type="checkbox"/> Ch1 NO _x	Range1 0-100 ppm Range2 0-2000 ppm at once
Ch2 SO ₂	Range1 0-100 ppm Range2 0-2000 ppm at once
Ch3 CO ₂	Range1 0-10 vol% Range2 0-20 vol% at once
Ch4 CO	Range1 0-100 ppm Range2 0-2000 ppm at once
Ch5 O ₂	Range1 0-10 vol% Range2 0-25 vol% each

↓   () 

F6_2_2.a

- (5) In the “Manual ZERO Calibration Selection” screen that appears, select “at once” or “each” by pressing the or key. When selecting “at once”, the Ch (components) to be set can be zero-calibrated at the same time. When selecting “each”, either of the Ch (components) to be selected is zero-calibrated. After setting, press the key.

Cal. Settings ZERO Cal.		Set each or at once at ZERO Calibration	
Ch1 NO _x	Range1 0-100 ppm Range2 0-2000 ppm		at once
Ch2 SO ₂	Range1 0-100 ppm Range2 0-2000 ppm		at once
Ch3 CO ₂	Range1 0-10 vol% Range2 0-20 vol%		at once
Ch4 CO	Range1 0-100 ppm Range2 0-2000 ppm		at once
Ch5 O ₂	Range1 0-10 vol% Range2 0-25 vol%		each

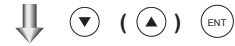

**End of
Manual Zero Calibration Setting**

F6_2_2_1.ai

To close the setting
To close the manual zero calibration setting or to cancel this mode midway, press the key. A previous screen will return.

F6_2_2note.ai

Example

Whether “each” or “at once” can be determined for each Ch (component).

- Setting “each”
Select the Ch (component) on the manual zero calibration screen and then perform zero calibration.
- Setting “at once”
At a manual zero calibration, zero of Ch (components) for which “at once” was selected can simultaneously be calibrated.
- * **When the cylinder air or atmospheric air is used for the zero gas, select “at once.”**

Manual Calibration screen

- When setting all components to “each”:

ZERO Cal.	ENT : Go on Calibration of selected Ch		ESC : Not calibration
Ch1 NO _x	▶Range1 0-100 ppm	▣ -2.1	
	▶Range2 0-2000 ppm		
Ch2 SO ₂	▶Range1 0-100 ppm	▣ -0.5	
	▶Range2 0-2000 ppm		
Ch3 CO ₂	▶Range1 0-10 vol%	▣ 0.00	
	▶Range2 0-20 vol%		
Ch4 CO	▶Range1 0-100 ppm	▣ 0.0	
	▶Range2 0-2000 ppm		
Ch5 O ₂	▶Range1 0-10 vol%	▣ 21.00	
	▶Range2 0-25 vol%		

A single cursor will appear.

- When setting all components to “at once”:

ZERO Cal.	ENT : Go on Calibration of selected Ch		ESC : Not calibration
Ch1 NO _x	▶Range1 0-100 ppm	▣ 0.0	
	▶Range2 0-2000 ppm		
Ch2 SO ₂	▶Range1 0-100 ppm	▣ 0.3	
	▶Range2 0-2000 ppm		
Ch3 CO ₂	▶Range1 0-10 vol%	▣ 0.00	
	▶Range2 0-20 vol%		
Ch4 CO	▶Range1 0-100 ppm	▣ -0.1	
	▶Range2 0-2000 ppm		
Ch5 O ₂	▶Range1 0-10 vol%	▣ 21.00	
	▶Range2 0-25 vol%		

F6_2_2_2.ai

Cursors will appear at all components where “at once” is set.

5.2.3 Setting of calibration range



This mode is used to set if the range of each Ch (component) at the calibration (manual calibration or auto calibration) should be calibrated with a single range or 2 ranges.

(1) During measurement, press the  key to display the User Mode.



↓ 



User Mode	Select an item with UP/DOWN and ENT Back with ESC
Switch Ranges <input checked="" type="checkbox"/> Calibration Parameters Alarm Setting Setting of Auto Calibration Setting of Auto Zero Calibration Setting of Peak Alarm Parameter Setting	

(2) Point the cursor to "Calibration Parameters" by pressing the  or  key. Press the  key.



↓  () 



Cal. Parameters	Select an item with UP/DOWN and ENT Back with ESC
Calibration Valve About ZERO Calibration <input checked="" type="checkbox"/> About Calibration Range Auto Calibration Components / Range	

(3) In the "Calibration Parameters" screen that appears, point the cursor to "About Calibration Range" by pressing the  or  key. Press the  key.

↓  () 

Cal. Settings	Select Ch No.		
Cal. Range			
<input checked="" type="checkbox"/> Ch1 NO _x	Range1 0-100 ppm Range2 0-2000 ppm		both
Ch2 SO ₂	Range1 0-100 ppm Range2 0-2000 ppm		current
Ch3 CO ₂	Range1 0-10 vol% Range2 0-20 vol%		current
Ch4 CO	Range1 0-100 ppm Range2 0-2000 ppm		both
Ch5 O ₂	Range1 0-10 vol% Range2 0-25 vol%		current

(4) In the "Calibration Range Ch Selection" screen that appears, point the cursor to the Ch you want to set by pressing the  or  key. Press the  key.

↓  () 

F6_2_3.ai

(5) On the “calibration range selection” screen that appears, select “both” or “current” by pressing the or key.

- If “both” is selected, zero or span calibration is performed with Range 1 and Range 2 of the selected Ch interlocked.
- If “current” is selected, zero or span calibration is performed only for the range displayed when calibration of selected Ch is performed.

Press the key after the selection, and the specified calibration is performed.

To close “Setting of Calibration Range”

To close “Setting of Calibration Range” or to cancel this mode midway, press the key. A previous screen will return.

F6_2_3note.ai

Cal. Settings		Set calibration range	
Cal. Range		current or both range	
Ch1 NO _x	Range1 0-100 ppm Range2 0-2000 ppm	both	
Ch2 SO ₂	Range1 0-100 ppm Range2 0-2000 ppm	current	
Ch3 CO ₂	Range1 0-10 vol% Range2 0-20 vol%	current	
Ch4 CO	Range1 0-100 ppm Range2 0-2000 ppm	both	
Ch5 O ₂	Range1 0-10 vol% Range2 0-25 vol%	current	

F6_2_3_1.ai

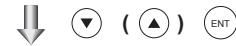

End of Calibration Range Setting

Example

Ch1 NO _x	Range 1: 0 to 100 ppm Range 2: 0 to 2000 ppm	both
Ch2 SO ₂	Range 1: 0 to 100 ppm Range 2: 0 to 2000 ppm	current

Ch1: Range 1 and Range 2 are calibrated together with zero and span calibration.
Ch2: Only currently displayed range is calibrated with zero and span calibration.

Note

To perform calibration for “both”, set the same calibration gas concentration for both ranges.

Manual Calibration screen

When setting NO_x and CO to “both”





ZERO Cal.	ENT : Go on calibration of selected Ch		
	ESC : Not calibration		
Ch1 NO _x	▶ Range1 0-100 ppm ▶ Range2 0-2000 ppm	◀ ▶	-0.6
Ch2 SO ₂	▶ Range1 0-100 ppm ▶ Range2 0-2000 ppm	◀ ▶	0.4
Ch3 CO ₂	▶ Range1 0-10 vol% ▶ Range2 0-20 vol%	◀ ▶	0.00
Ch4 CO	▶ Range1 0-100 ppm ▶ Range2 0-2000 ppm	◀ ▶	-0.1
Ch5 O ₂	▶ Range1 0-10 vol% ▶ Range2 0-25 vol%	◀ ▶	21.00

F6_2_3_2.ai

Two cursors will appear in both ranges (Ch1 and Ch4).



5.2.4 Setting of auto calibration component/range



Select the Ch (component) and the range with which auto calibration is to be performed. The Ch for which “AR” has been selected as range switch mode is calibrated in the range set here even when auto calibration is performed.

- (1) During measurement, press the  key to display the User Mode.
- (2) Point the cursor to “Calibration Parameters” by pressing the  or  key. Press the  key.



↓ 



User Mode	Select an item with UP/DOWN and ENT Back with ESC
Switch Ranges <input checked="" type="checkbox"/> Calibration Parameters Alarm Setting Setting of Auto Calibration Setting of Auto Zero Calibration Setting of Peak Alarm Parameter Setting	

- (3) In the “Calibration Parameters” screen that appears, point the cursor to “Auto Calibration Components / Range” by pressing the  or  key. Press the  key.

↓   

Cal. Parameters	Select an item with UP/DOWN and ENT Back with ESC
Calibration Valve About ZERO Calibration About Calibration Range <input checked="" type="checkbox"/> Auto Calibration Components / Range	

- (4) In the “Auto Calibration Components / Range” selection screen that appears, point the cursor to the Ch you want to set by pressing the  or  key. Press the  key.

↓   

Cal. Settings Auto Cal.	Select Ch No.
<input checked="" type="checkbox"/> Ch1 NO _x	▶Range1 0-100 ppm Range2 0-2000 ppm enable
Ch2 SO ₂	▶Range1 0-100 ppm Range2 0-2000 ppm enable
Ch3 CO ₂	▶Range1 0-10 vol% Range2 0-20 vol% enable
Ch4 CO	▶Range1 0-100 ppm Range2 0-2000 ppm enable
Ch5 O ₂	▶Range1 0-10 vol% ▶Range2 0-25 vol% enable

↓   

FB_2_4.a1

- (5) The cursor next to the range of the selected Ch (component) is highlighted. Select the range to be calibrated mainly by pressing the ▲ or ▼ key.
- (6) Then press the ENT key, and calibration is performed in the selected range.

To close "Auto Calibration Component/range" setting

Auto calibration and the manual calibration of the component with which "AR" has been selected as range switch mode are performed in the range selected here. In this case, once the calibration is started, the range is automatically switched, and on completion of the calibration, the original range is resumed. The range identification contact is interlocked with the range after the switch. However, if the hold setting is set to "ON," the contact status before calibration is maintained.

- (7) Press the ► key in the state described in (5), and the highlight is switched between "enable" and "disable" auto calibration.
- (8) Select "enable" of "disable" by pressing the ▲ or ▼ key.
- (9) Then press the ENT key.

To close the setting

Press the ESC key to exit Auto Calibration components/range setting, and the previous screen appears.

Operation by setting

Auto calibration is performed under the following rules.

1. Zero calibration is performed at the same time, for the Ch (component) with which "enable" is selected at the time of auto calibration and auto zero calibration.
2. Span calibration is performed in the order from smallest Ch No., for the Ch (component) with which "enable" is selected at the time of auto calibration.

Note

ZERO calibration on auto calibration and auto zero calibration of the component with which "enable" is selected are performed in batch irrespective of the description in "6.2.2 Setting of manual zero calibration."

Cal. Settings Auto Cal.		Select a range for auto calibration	
Ch1 NOx	▶ Range1 0-100 ppm Range2 0-2000 ppm		enable
Ch2 SO2	▶ Range1 0-100 ppm Range2 0-2000 ppm		enable
Ch3 CO2	▶ Range1 0-10 vol% Range2 0-20 vol%		enable
Ch4 CO	▶ Range1 0-100 ppm Range2 0-2000 ppm		enable
Ch5 O2	▶ Range1 0-10 vol% Range2 0-25 vol%		enable

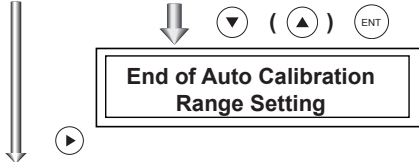

Cal. Settings Auto Cal.		Set enable or disable for auto calibration	
▶ Ch1 NOx	Range1 0-100 ppm Range2 0-2000 ppm		enable
Ch2 SO2	Range1 0-100 ppm Range2 0-2000 ppm		enable
Ch3 CO2	Range1 0-10 vol% Range2 0-20 vol%		enable
Ch4 CO	Range1 0-100 ppm Range2 0-2000 ppm		enable
Ch5 O2	Range1 0-10 vol% Range2 0-25 vol%		enable

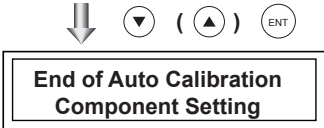

F6_2_4_1.a



5.3 Alarm setting



5.3.1 Setting of alarm values



The High/Low limit alarm output setting for the measured concentration and power off alarm (alarm 6 only) setting can be made during measurement. Arbitrary 6 alarm contact outputs can be used.

To change alarm setting, set the alarm ON/OFF setting to OFF, and then change the value.

(1) During measurement, press the  key to display the User Mode.

(2) Point the cursor to "Alarm Setting" by pressing the  or  key. Press the  key.

(3) After the alarm No. selection screen has appeared, point the cursor to the Alarm No. you want to set by pressing  or  key. Press the  key.



(4) After the alarm item selection screen has appeared, operate the  or  key until the cursor is aligned with a desired item and press the  key.

Note



Set the values so that H-limit value > L-limit value and that (H-limit value - L-limit value) > hysteresis.

↓ 



User Mode	Select an item with UP/DOWN and ENT Back with ESC
Switch Ranges Calibration Parameters <input checked="" type="checkbox"/> Alarm Setting Setting of Auto Calibration Setting of Auto Zero Calibration Setting of Peak Alarm Parameter Setting	

↓  () 

Alarm Setting	Select Alarm No. or Hysteresis setting
<input checked="" type="checkbox"/> Alarm-1 Alarm-2 Alarm-3 Alarm-4 Alarm-5 Alarm-6	
Hysteresis	00 %FS

↓  () 

Alarm Setting Alarm-1	Select an item with UP/DOWN and ENT Back with ESC
<input checked="" type="checkbox"/> Channel Ch 1 H-Limit Range 1 100.0 ppm Range 2 2000 ppm L-Limit Range 1 000.0 ppm Range 2 0000 ppm Kind of Alarm High ON / OFF OFF	

↓  () 

FB_3_1.ai

(5) After setting, the alarm setting is now completed by pressing the **ENT** key.

To close the "Alarm Setting"
To close the "Alarm Setting" or to cancel this mode midway, press the **ESC** key. A previous screen will return.

Setting range
0% to 100%FS (Settable in each range).

Cursor for setting value

Alarm Setting	Set Value
Alarm-1	
Channel	Ch 1
H-Limit Range 1	100.0 ppm
Range 2	2000 ppm
L-Limit Range 1	000.0 ppm
Range 2	0000 ppm
Kind of Alarm	High
ON / OFF	OFF

↓ (Down Arrow) ◀ (Left Arrow) ▶ (Right Arrow) ▲ (Up Arrow) ENT

End of Alarm Setting

F6_3_1_2.ai

Description of setting items

The alarm contact assigned the same number as the alarm is operated accordingly.

Channel: Channel setting targeted for issuance of alarm (Power off alarm can be selected for alarm 6.) One Ch No. can be selected for multiple alarms.

H-Limit value: Sets the high limit value (concentration) of alarm.

L-Limit value: Sets the low limit value (concentration) of alarm.

Kind of Alarm: Selects one of High limit alarm, Low limit alarm, and High limit or Low limit alarm, HH limit alarm, and LL limit alarm.
 High, HH ... Alarm contact closes when above H-limit alarm.
 Low, LL ... Alarm contact closes when below L-limit alarm.
 High or Low ... Alarm contact closes when above H-limit value or below lower limit value.

If "Power" is selected for Channel, the contact is closed at all times while the power is on irrespective of the setting made here. (Alarm-6 only)

ON/OFF: Enables the alarm function if set at ON, or disables the alarm function if set at OFF.

- The H-limit value cannot be set below the L-limit value, and the L-limit value cannot be set above the H-limit value. If it is desired to set the H-limit value below the L-limit value already stored in the memory, reduce the L-limit value beforehand, and vice versa.

Typical on-screen display when an alarm occurs

When an H-limit alarm occurs, the "H-alarm" message comes on in the field of relevant Ch (component). ("L-alarm" for L-limit alarm, "HH-alarm" for HH-limit alarm, and "LL-alarm" for LL-limit alarm)

1	H-alarm	ppm
2	SO ₂ (0-100)	00 ppm
3	CO ₂ (0-10)	0.003 vol%
4	CO (0-100)	00 ppm
5	O ₂ (0-25)	21.00 vol%

F6_3_1_3.ai

Note
For 10 minutes after turning on power, the alarm judgment is inactive.

5.3.2 Hysteresis setting

To prevent chattering of an alarm output near the alarm setting values, set the value of hysteresis.

- (1) In the "Alarm No. Selection" screen that appears, point the cursor to "Hysteresis" by pressing the \blacktriangle or \blacktriangledown key. Press the ENT key.
- (2) In the "Hysteresis Value Setting" screen that appears, enter hysteresis values. For the value entry, 1-digit value is increased or decreased by pressing the \blacktriangle or \blacktriangledown key, and pressing the \blacktriangleright key moves the digit. After setting, press the ENT key.

To close the "Hysteresis Setting" screen, press the ESC key. A previous screen will return.

Setting range
 0 to 20% of full scale
 [% full scale (FS)] represents the percentage with the width of the range of each component regarded as 100 %.

Alarm Setting	Select Alarm No. or Hysteresis setting
Alarm-1 Alarm-2 Alarm-3 Alarm-4 Alarm-5 Alarm-6	
\blacktriangleright Hysteresis	00 %FS

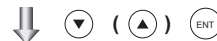

Alarm Setting	Set Hysteresis 0 to 20%FS available
Alarm-1 Alarm-2 Alarm-3 Alarm-4 Alarm-5 Alarm-6	
Hysteresis	00 %FS



End of Hysteresis Setting

Note
 The hysteresis is common to all alarms (components).

Hysteresis (In case of upper limit alarm)

An alarm output is turned ON if measurement value exceeds the upper limit value as shown below. Once the alarm output has been turned ON, it is not turned OFF as long as the indication does not fall below the hysteresis width from the upper limit value.

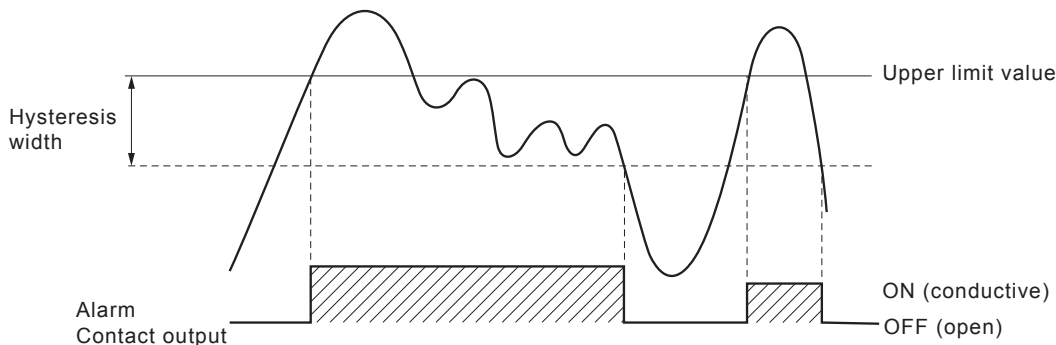





F6_3_2_1.ai

5.4 Setting of auto calibration

5.4.1 Auto calibration







Auto calibration is automatically carried out at the time when zero calibration and span calibration are set.



Before changing the setting of auto calibration, set the ON/OFF to OFF.

- (1) During measurement, press the  key to display the User Mode.
- (2) Point the cursor to "Setting of Auto Calibration" by pressing the  or  key. Press the  key.

↓ 

User Mode	Select an item with UP/DOWN and ENT Back with ESC
Switch Ranges Calibration Parameters Alarm Setting <input checked="" type="checkbox"/> Setting of Auto Calibration Setting of Auto Zero Calibration Setting of Peak Alarm Parameter Setting	

- (3) In the "Setting of Auto Calibration" screen that appears, point the cursor to any item you want to set by pressing the  or  key. Press the  key.
- (4) In the "Auto Calibration Parameter Setting" screen that appears, perform the value entry or the setting. For the value entry or setting change, use the  or  key. To change the setting, use the  key to move the cursor to the right.

↓   

Set Auto Cal.	Select setting item
<input checked="" type="checkbox"/> Start Time SUN 12:00 Cycle 07 day Flow Time ON / OFF OFF <div style="text-align: right;">Time : MON 12:34</div>	
Auto Calibration Run	



After setting, press the  key, and setting of auto calibration is carried out.

Description of setting items



- Start Time : Setting at the first calibration (day of the week, hour, minute)
- Cycle : A period between the start time of one calibration and another (unit : hour/day)
- Flow Time : The time required for replacement by calibration gas
Time required for replacement of sample gas after the calibration is completed (Set by calibration gas. See the next page.)
- ON/OFF : ON/OFF of auto calibration

To close "Setting of Auto calibration"

To close the "Setting of Auto calibration" or cancel this mode midway, press the  key.
A previous screen will return.

↓   

Set Auto Cal.	Set Start Time
Start Time SUN 12:00 Cycle 07 day Flow Time ON / OFF OFF <div style="text-align: right;">Time : MON 12:34</div>	
Auto Calibration Run	

↓    

End of Auto Calibration Setting

FB_4_1.a

<Gas flow time> setting

- Press the **ENT** key in a state where the cursor is placed next to "Flow Time," and the flow time setting screen shown at right appears.

Set Auto Cal.	Select setting item
Start Time	SUN 12:00
Cycle	07 day
<input checked="" type="checkbox"/> Flow Time	ON / OFF OFF
Time : MON 12:34	
Auto Calibration Run	



- On the flow time setting screen that appears, move the cursor to the gas you want to change the setting by pressing the **▲** or **▼** the key, and then press the **ENT** key.

Set Auto Cal.	Select a Flow time
<input checked="" type="checkbox"/> Zero	350 sec
Ch1 Span	350 sec
Ch2 Span	350 sec
Ch3 Span	350 sec
Ch4 Span	300 sec
Ch5 Span	300 sec
Ex. Time	300 sec



- The highlighted value can be changed. Change the value by pressing the **▲** or **▼** key, and then move the cursor to the right by pressing the **▶** key.
- After changing the value, press the **ENT** key.
- Press the **ESC** key to return to the automatic calibration setting screen.

Set Auto Cal.	Set Flow Time of Calibration gas 60 to 900 sec.
Zero	350 sec
Ch1 Span	350 sec
Ch2 Span	350 sec
Ch3 Span	350 sec
Ch4 Span	300 sec
Ch5 Span	300 sec
Ex. Time	300 sec



End of Gas Flow Time Setting

Note) Only the Chs used are displayed on this screen.
 The Ex. time is the output signal hold extension time after the completion of calibration.
 It is valid only when the hold setting is set to "ON."
 The Ex. time set here is also the hold extension time at the time of manual calibration.

F6_4_1_2.ai

Auto calibration status contact output is closed during auto calibration (including Ex. time), and is open in other cases.

Example

Start Time	SUN	12:00
Cycle	1	day
Flow Time	Zero	350 sec
	Ch1 Span	350 sec
	Ch2 Span	350 sec
	Ch3 Span	350 sec
	Ch4 Span	300 sec
	Ch5 Span	300 sec
	EX. time	300 sec
ON/OFF	ON	

In case where auto calibration is carried out at the above setting.

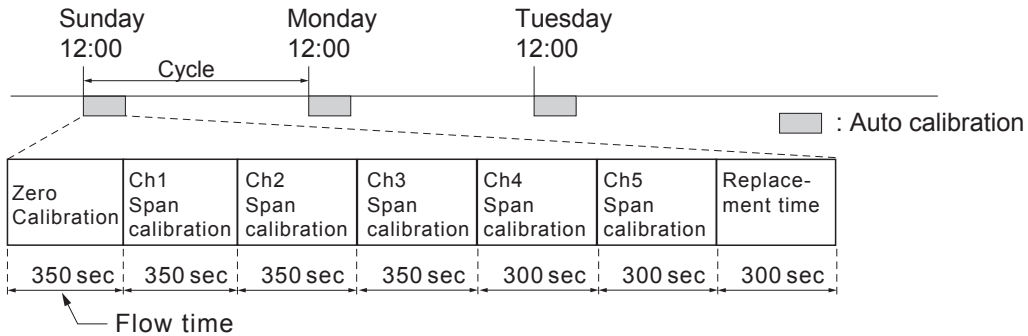

(An example of “Ch1: through Ch5: enable”, as given in Item 6.2.4 “Auto Calibration Components/ range”)

Setting range

Cycle : 1 to 99 hours or 1 to 40 days (initial value 7 days)
 Flow time : 60 to 900 sec (initial value 300 sec)

Caution

- When an auto calibration starts, the measurement screen automatically appears.
- Any key operation other than key lock ON/OFF and “Stop Auto Calibration” (see Item 6.4.2) is not permitted during auto calibration. “Stop Auto Calibration” cannot be performed with the key lock to ON. To cancel auto calibration forcedly, set the key lock to OFF and then execute “Stop Auto Calibration”.
- Turn on the power again after it is turned off (including the case of power failure) at the time set as the next start time in auto calibration, and then repeat it in the set cycle.

Remote start

Whether the auto calibration is set at ON or OFF, an auto calibration is available by keeping the remote start input closed for at least 1.5 seconds.

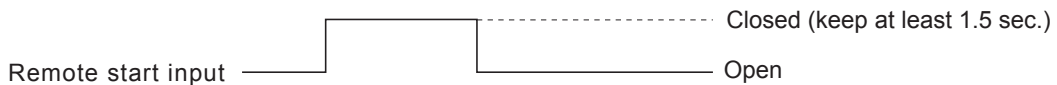







F6_4_1remote.ai



5.4.2 Forced run/stop of auto calibration

Auto calibration can be performed just once or forcibly stopped while the calibration is performed.

5.4.2.1 Execution of auto calibration (only once)

- (1) Display the User Mode screen. Move the cursor to "Setting of Auto Calibration" by pressing the  or the  key, and then press the  key.

- (2) In the "Setting of Auto Calibration" item selection screen that appears, point the cursor to "Auto Calibration Run" by pressing the  or  key. Press the  key.

- (3) "Run" is highlighted, displaying a message to confirm the execution of auto calibration. Press the  key to execute the auto calibration forcibly, and press the  key to cancel.

User Mode	Select an item with UP/DOWN and ENT Back with ESC
Changeover of Range Setting about Calibration Alarm Setting ▣ Setting of Auto Calibration Setting of Auto Zero Calibration Setting of Peak Alarm Parameter Setting	

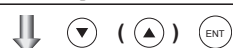

Set Auto Cal.	Select setting item
Start Time SUN 12:00 Cycle 07 day Flow Time ON / OFF OFF Time : MON 12:34	
▣ Auto Calibration Run	

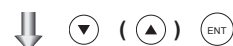









Set Auto Cal.	Auto Cal. Run ENT : Run / Stop ESC : Cancel
Start Time SUN 12:00 Cycle 07 day Flow Time ON / OFF OFF Time : MON 12:34	
Auto Calibration Run	

FB_4_2.ai

5.4.2.2 Forced stop of auto calibration

This mode is used to stop the auto calibration forcibly.

- (1) In the User Mode that is displayed, point the cursor to "Setting of Auto Calibration" by pressing the  or  key. Press the  key.
- (2) In the "Setting of Auto Calibration" item selection screen that appears, point the cursor to "Auto Calibration Stop" by pressing the  or  key. Press the  key.
(“Auto Calibration Stop” appears when the screen is selected while auto calibration is performed.)
- (3) “Stop” is highlighted, displaying a message to confirm the stop of auto calibration. Press the  key to stop the auto calibration forcibly, and press the  key to cancel (not stopped).

User Mode	Select an item with UP/DOWN and ENT Back with ESC
Changeover of Range Setting about Calibration Alarm Setting <input checked="" type="checkbox"/> Setting of Auto Calibration Setting of Auto Zero Calibration Setting of Peak Alarm Parameter Setting	

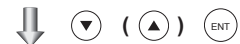

Set Auto Cal.	Select setting item
Start Time SUN 12:00 Cycle 07 day Flow Time 300 sec ON / OFF OFF Time : MON 12:34	
<input checked="" type="checkbox"/> Auto Calibration Stop	

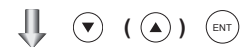

Set Auto Cal.	Auto Cal. Stop ENT : Run / Stop ESC : Cancel
Start Time SUN 12:00 Cycle 07 day Flow Time 300 sec ON / OFF OFF Time : MON 12:34	
Auto Calibration Stop	

FB_4_2_1.a1

“Auto Calibration” screen

Example

In case where setting the auto calibration components (see Item 6.2.4) to “Ch1: enable” and “Ch2: enable”

• Zero calibration

A message, “ZERO cal.” blinks at Ch1 and Ch2.

ZERO cal.	0.5	ppm
ZERO cal.	0.3	ppm
Ch 3 CO ₂ (0-10)	0.000	vol%
Ch 4 CO (0-100)	0.0	ppm
Ch 5 O ₂ (0-25)	21.02	vol%

• Ch1 span calibration

A message, “SPAN cal.” blinks at Ch1.

SPAN cal.	90.8	ppm
Ch 2 SO ₂ (0-100)	0.0	ppm
Ch 3 CO ₂ (0-10)	0.00	vol%
Ch 4 CO (0-100)	0.0	ppm
Ch 5 O ₂ (0-25)	0.00	vol%

• Ch2 span calibration

A message, “SPAN cal.” blinks at Ch2.

Ch 1 NO _x (0-100)	0.0	ppm
SPAN cal.	95.0	ppm
Ch 3 CO ₂ (0-10)	0.00	vol%
Ch 4 CO (0-100)	0.0	ppm
Ch 5 O ₂ (0-25)	0.00	vol%

F6_4_2Auto-screen.ai

Caution

During auto calibration, any key operation is not permitted other than operations such as key lock ON/OFF and “Stop Auto Calibration.”

When the key lock is set at ON, even the “Auto Calibration Stop” cannot be used.

To stop “Auto Calibration” forcedly, set the key lock to OFF and then execute “Auto Calibration Stop.”

5.5 Setting of auto zero calibration

5.5.1 Auto zero calibration

Auto zero calibration is automatically carried out at the time when zero calibration is set. Components for which a calibration is to be made are determined by setting of auto calibration component in Item 6.2.4.

Before changing the setting of auto zero calibration, set the ON/OFF to OFF.

- (1) During measurement, press the **(MODE)** key to display the User Mode.
- (2) Point the cursor to "Setting of Auto Zero Calibration" by pressing the **(▲)** or **(▼)** key. Press the **(ENT)** key.
- (3) In the "Setting of Auto Zero Calibration" screen that appears, point the cursor to any item you want to set by pressing the **(▲)** or **(▼)** key. Press the **(ENT)** key.
- (4) In the "Auto Zero Calibration Parameter Setting" screen that appears, perform the value entry or the setting. For the value entry or setting change, use the **(▲)** or **(▼)** key. To change the setting, use the **(▶)** key to move the cursor to the right. After setting, press the **(ENT)** key, and auto zero calibration is carried out by the entered setting value.

Description of setting items

- Start Time : Setting at the first calibration (day of the week, hour, minute)
- Cycle : A period between the start time of one calibration and another (unit : hour/day)
- Flow Time : The time required for the calibration gas to be replaced in the cell
- ON/OFF : ON/OFF of auto zero calibration

To close "Setting of Auto Zero calibration"

To close the "Setting of Auto Zero calibration" or cancel this mode midway, press the **(ESC)** key. A previous screen will return.

↓ (MODE)

User Mode	Select an item with UP/DOWN and ENT Back with ESC
Switch Ranges Calibration Parameters Alarm Setting Setting of Auto Calibration <input checked="" type="checkbox"/> Setting of Auto Zero Calibration Setting of Peak Alarm Parameter Setting	

↓ (▼) (▲) (ENT)

Set Auto Zero Cal.	Select setting item
<input checked="" type="checkbox"/> Start Time SUN 12:00 Cycle 07 day Flow Time 300 sec. ON / OFF OFF Time : MON 12:34	
Auto Zero Calibration Run	

↓ (▼) (▲) (ENT)

Set Auto Zero Cal.	Set Start Time
<input checked="" type="checkbox"/> Start Time SUN 12:00 Cycle 07 day Flow Time 300 sec. ON / OFF OFF Time : MON 12:34	
Auto Zero Calibration Run	

↓ (▼) (▲) (▶) (ENT)

End of Auto Zero Calibration Setting

F6_5_1.ai

Auto calibration status contact output is closed during auto zero calibration, and is open in other cases.

Example

Start Time	SUN	12:00
Cycle	12	hour
Flow Time	300	sec
ON/OFF	ON	

In case where auto zero calibration is carried out at the above setting.

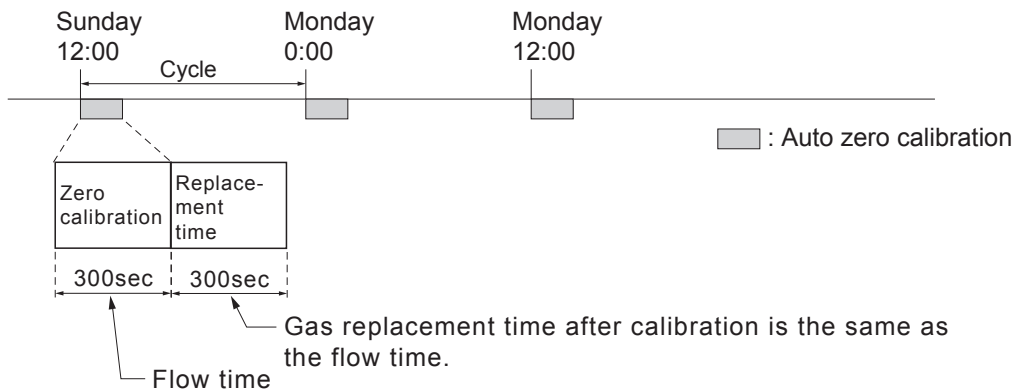

(An example of “Ch1: through Ch5: enable”, as given in Item 6.2.4 “Auto Calibration Components/ range”)

Setting range

Cycle : 1 to 99 hours or 1 to 40 days (initial value 7 days)

Flow time : 60 to 900 sec (initial value 300 sec)



Caution

- When an auto zero calibration starts, the measurement screen automatically appears.
- Any key operation other than key lock ON/OFF and “Stop Auto Zero Calibration” (see Item 6.5.2) is not permitted during auto zero calibration. “Stop Auto Zero Calibration” cannot be performed with the key lock to ON. To cancel auto zero calibration forcedly, set the key lock to OFF and then execute “Stop Auto Zero Calibration.”
- If the auto calibration period and auto zero calibration period have overlapped, the auto calibration is retained, ignoring the auto zero calibration of that period.
- When the hold setting is set to ON, the hold time of auto calibration contact and measurement value output signal is extended after calibration for gas replacement time.
- Turn on the power again after it is turned off (including the case of power failure) at the time set as the next start time in auto zero calibration, and then repeat it in the set cycle.

5.5.2 Forced run/stop of auto zero calibration



Auto zero calibration can be performed just once, or auto zero calibration can be forcibly stopped during calibration.

5.5.2.1 Execution of auto zero calibration (just once)

- (1) Move the cursor to “Setting of Auto Zero Calibration” by pressing the  or  key on the User Mode screen, and then press the  key.



User Mode	Select an item with UP/DOWN and ENT Back with ESC
Switch Ranges Calibration Parameters Alarm Setting Setting of Auto Calibration <input checked="" type="checkbox"/> Setting of Auto Zero Calibration Setting of Peak Alarm Parameter Setting	

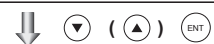

- (2) In the “Setting of Auto Zero Calibration” item selection screen that appears, point the cursor to “Auto Zero Calibration Run” by pressing the  or  key. Press the  key.

Set Auto Zero Cal.	Select setting item
Start Time SUN 12:00 Cycle 07 day Flow Time 300 sec ON / OFF OFF Time : MON 12:34	
<input checked="" type="checkbox"/> Auto Zero Calibration Run	





- (3) “Run” is highlighted, displaying a message to confirm execution of auto zero calibration. Press the  key to execute the calibration forcibly, and press the  key to cancel.

Set Auto Zero Cal.	Auto Zero Run ENT : Run / STOP ESC : Cancel
Start Time SUN 12:00 Cycle 07 day Flow Time 300 sec ON / OFF OFF Time : MON 12:34	
Auto Zero Calibration Run	

FE_5_2.ai



5.5.2.2 Forced stop of auto zero calibration

This mode is used to cancel the auto zero calibration forcibly.

- (1) In the User Mode that is displayed, point the cursor to “Setting of Auto Zero Calibration” by pressing the  or  key. Press the  key.

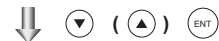

User Mode	Select an item with UP/DOWN and ENT Back with ESC
Switch Ranges Calibration Parameters Alarm Setting Setting of Auto Calibration <input checked="" type="checkbox"/> Setting of Auto Zero Calibration Setting of Peak Alarm Parameter Setting	

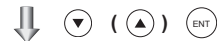

- (2) In the “Setting of Auto Zero Calibration” item selection screen that appears, point the cursor to “Auto Zero Calibration Stop” by pressing the  or  key. Press the  key. (“Auto Zero Calibration Stop” appears when the screen is selected while auto zero calibration is performed.)

Set Auto Zero Cal.	Select setting item
Start Time	SUN 12:00
Cycle	07 day
Flow Time	300 sec
ON/OFF	OFF
Time : THU 10:56	
<input checked="" type="checkbox"/> Auto Zero Calibration Stop	



- (3) “Stop” is inverted. A message appears, prompting you to verify that you want to stop auto zero calibration. Press the  key to stop the auto zero calibration forcibly, and the  key to cancel (not stopped).

Set Auto Zero Cal.	Auto Zero Stop ENT : Run / Stop ESC : Cancel
Start Time	SUN 12:00
Cycle	07 day
Flow Time	300 sec
ON/OFF	OFF
Time : THU 10:56	
Auto Zero Calibration Stop	

F6_5_2_1.ai

"Auto Zero Calibration" screen

Example

In case where setting the auto calibration components (see Item 6.2.4) to "Ch1: enable" and "Ch2: enable"

• Zero calibration

A message, "ZERO cal." blinks at Ch1 and Ch2.

Ch 1	ZERO cal.	0.5	ppm
Ch 2	ZERO cal.	0.3	ppm
Ch 3	CO ₂ 0-10	0.00	vol%
Ch 4	CO 0-100	0.0	ppm
Ch 5	O ₂ 0-25	21.02	vol%

F6_5_2gamen.ai

Caution

During auto zero calibration, any key operation is not permitted other than operations such as key lock ON/OFF and "Stop Auto Zero Calibration."

When the key lock is set at ON, even the "Stop Auto Zero Calibration" cannot be used.

To stop "auto zero calibration" forcibly, set the key lock to OFF and then execute "Auto Zero Calibration Stop."

5.6 Peak alarm setting

When the peak number of times CO concentration exceeds the upper limit value during measurement exceeds the set number, an alarm is provided.

The peak alarm and this setting screen appear only when an option is added.

(1) Press the **(MODE)** key in the Measurement mode, and the User mode appears.

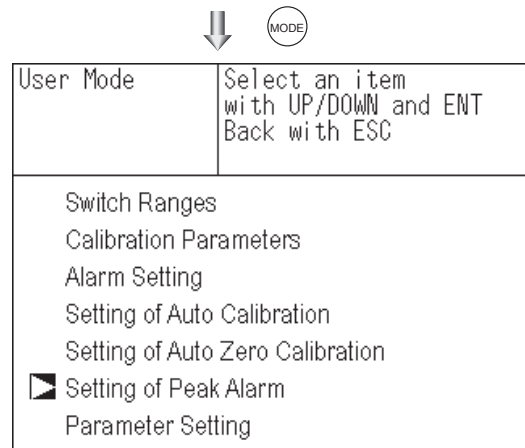

(2) Point the cursor to "Setting of Peak Alarm" by pressing the **(▲)** or **(▼)** key. Press the **(ENT)** key.

(3) In the "Peak Alarm Setting" item selection screen that appears, point the cursor to any item you want to set by pressing the **(▲)** or **(▼)** key. Press the **(ENT)** key.

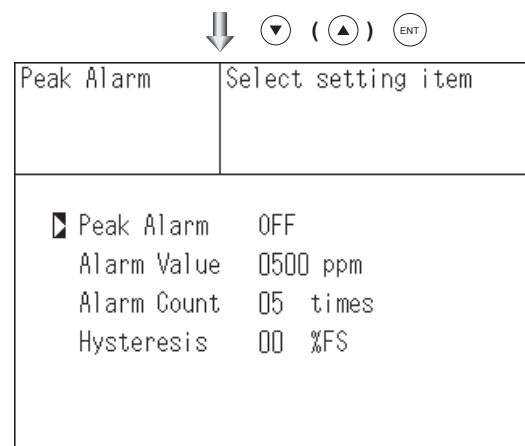

(4) Then, enter numeric values and perform the setting.

Entering the numeric values or setting the items should be carried out by using the **(▲)** or **(▼)** key.

After setting, press the **(ENT)** key, and the set values are saved.

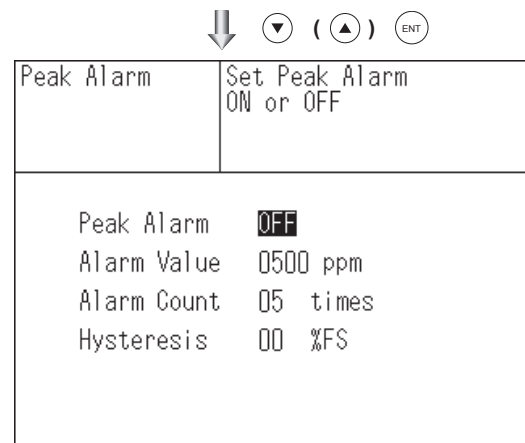

Description of setting items

- Peak Alarm : ON/OFF of peak alarm
- Alarm Value : If measuring value exceeds the set alarm value, a peak counter counts 1 time.
- Alarm Count : When a peak in excess of the setting time occurs, a peak count alarm output is provided.
- Hysteresis : To prevent possible chattering when the measuring value may exceed the set peak concentration by only 1 time, the peak count has an allowance in the hysteresis width.



Setting range

- Alarm value : 10 to 1000 ppm → 5 ppm step (initial value: 500 ppm)
- Alarm count : 1 to 99 times → (initial value: 5 times)
- Hysteresis : 0 to 20% of full scale → (initial value: 0% of full scale)
 [% full scale] represents the percentage with the CO range regarded as 100%.

Action of peak alarm

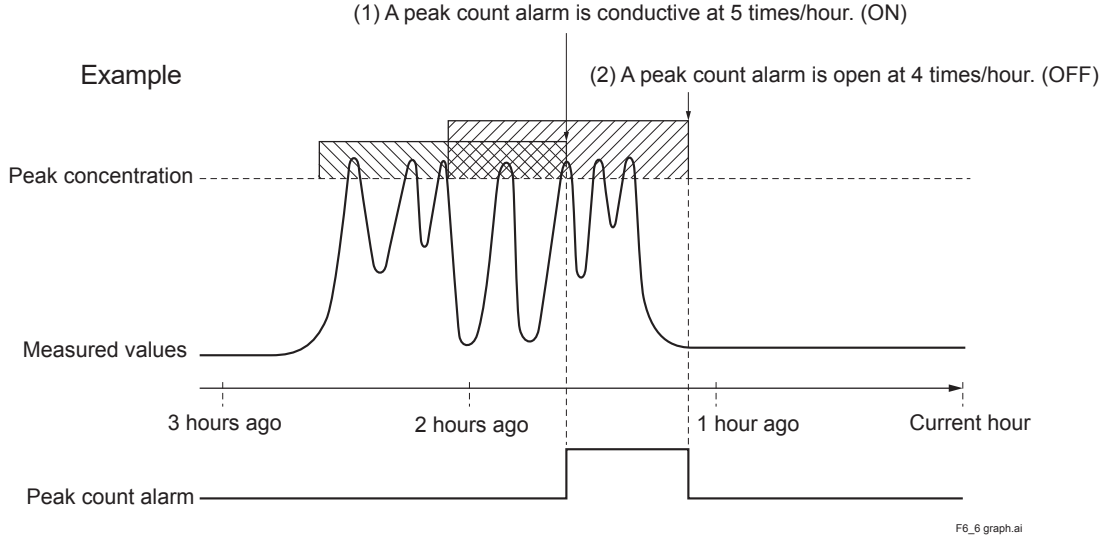

If CO concentration exceeds the alarm value, counting will begin. If the number of peaks is over the set times per hour, a peak alarm contact output becomes closed (ON). If it is less than the set times per hour, it is open (OFF). Since 5 times of peaks /hour is marked at (1) section from the above graph, the peak count alarm is turned ON. Since peaks of more than 5 times per 1 hour occur at the interval between (1) and (2), the peak count alarm remains ON. Since at (2), peaks are reduced to 4 times per hour, it is turned OFF.

Like the hysteresis of the alarm setting , the hysteresis prevents possible chattering when measured gas is fluctuated near the alarm value.

* For 10 minutes after the power is turned ON, a peak alarm counting is not carried out.

Releasing peak count alarm

To release the peak count alarm, set the peak alarm to OFF. Turning on the peak alarm initiates counting from 0.







5.7 Parameter setting

It allows you to carry out the parameter setting such as time, key lock, etc., as required. Items to be set are as follows:

Description of setting items

- **Current Time :** Current year, month, date, day of the week, hour, and minute setting
(The display appears in this order.)
Note: The clock backup time is 2 days. If power is turned on after it is kept off for 2 days or longer, make the time setting again.
- **Key Lock :** Sets with ON/OFF so that any key operation except the key lock OFF cannot be performed.
- **Output Hold :** Sets whether Calibration Output is held or not, and the holding value setting.
- **Reset Av. Output :** Resets the average value.
- **Response time :** Sets the response time of electrical system.
- **Average Period :** Sets the moving average time.
- **Backlight Timer :** Sets automatic OFF of the backlight of display unit and the time until backlight out.
- **Contrast:** Contrast setting
- **Maintenance mode :** Enters passwords to switch to the Maintenance mode.

* For the maintenance mode, see Item 6.8.

- (1) To display the User mode, press the  key in the measurement mode.
- (2) Point the cursor to "Parameter Setting" by pressing the  or  key. Press the  key.
- (3) In the "Parameter Setting" screen that appears, point the cursor to any item you want to set by pressing the  or  key. Press the  key.

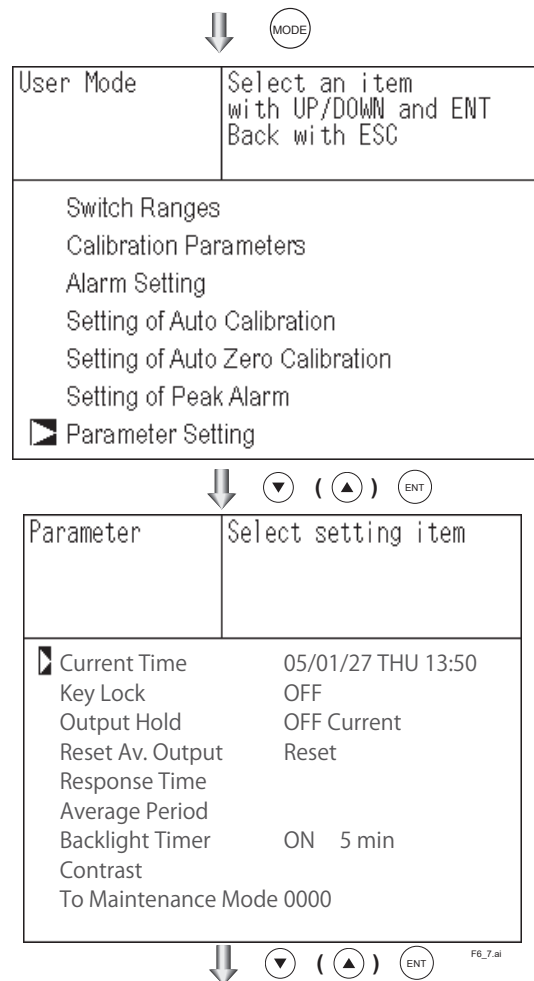

(4). In the Parameter Setting screen that appears, enter the numeric values and set the items. Entering the numeric values or setting the items should be carried out by using the ▲ or ▼ key. To move the cursor to the right, press the ► key. After setting, press the ENT key, that the parameter setting is carried out with the value you set.

Parameter	Set day of week
Current time	05/01/27 THU 13:50
Key Lock	OFF
Output Hold	OFF Current
Reset Av. Output	Reset
Response Time	
Average Period	
Backlight Timer	ON 5 min
Contrast	
To Maintenance Mode	0000



End of Parameter Setting

To close Parameter Setting screen
To close the "Parameter Setting" screen or cancel this mode midway, press the ESC key. A previous screen will return.

Setting Range

- Hold setting : 0 to 100% FS
- Response time : 1 to 60 sec. (initial value: 15 sec)
- Average period : 1 to 59 min or 1 to 4 hours (initial value: 1 hour)
When setting the unit of 1 to 59 minutes is terms of minute or 1 to 4 hours with hour
- Backlight Timer : 1 to 60 min (initial value: OFF)
- Contrast : Contrast setting
- Maintenance mode : 0000 to 9999 (initial value: 0000)

Output Hold

By setting an output hold to ON, an output signal of each channel are held during the calibration (manual calibration and auto calibration) and for the gas flow time (refer to Item 6.4, Setting of Auto Calibration). Regardless of Hold ON/OFF setting, an output signal can be held via an external input.

(1) Manual calibration

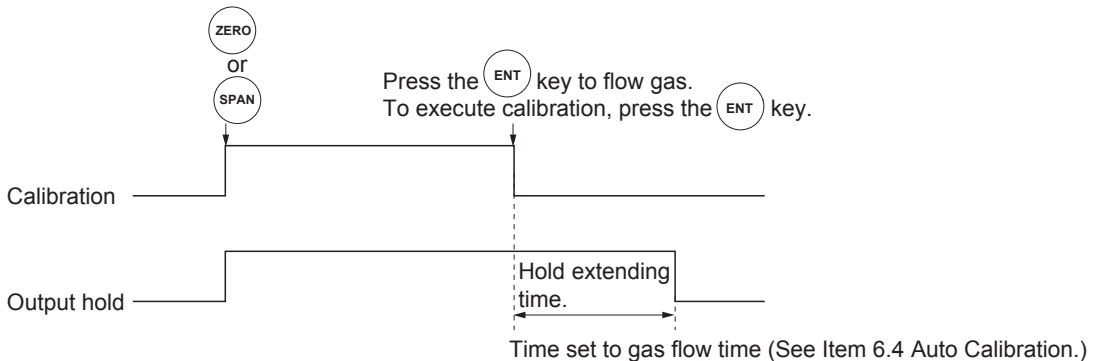

F6_7_1.ai

(2) Auto calibration

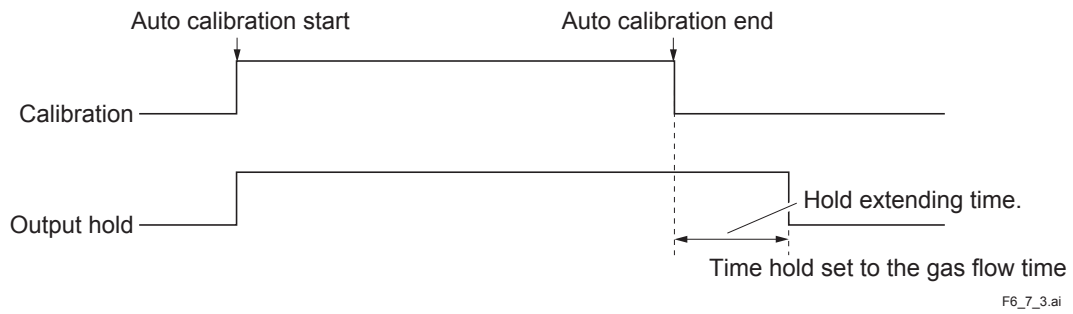

(3) External hold

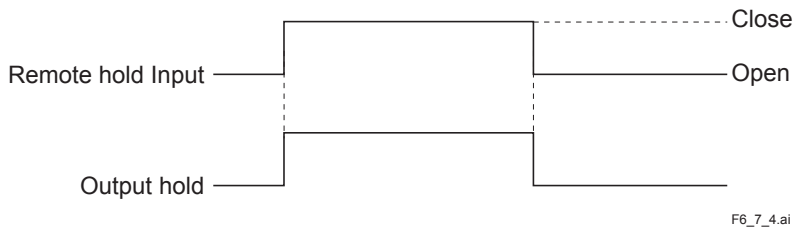

(4) Screen display during Holding

The “on Hold” message blinks on the measuring screen.

Since the screen displays the process of calibration is displayed during the manual calibration, “on Hold” is not displayed even if the output signal is held, but the screen is displayed with the hold extending time.



(5) If calibration is cancelled after the calibration gas is supplied regardless of during manual calibration or auto calibration, the holding extending time will be performed.



(6) You can select the value for hold from the value immediately before entering output hold, “current,” and arbitrary value, “setting.”

Follow the procedures shown below to make the setting.



1) Press the  key in a state where the cursor is placed next to Hold.





Parameter	Select setting item
Current Time	05/01/27 THU 13:50
Key Lock	OFF
 Output Hold	ON Current
Reset Av. Output	Reset
Response Time	
Average Period	
Backlight Timer	ON 5 min
Contrast	
To Maintenance Mode	0000

2) “ON” or “OFF” is highlighted. Press the  or the  key to select ON or OFF. Press the  key to return to (1).



 

Parameter	Select Hold ON or OFF
Current Time	05/01/27 THU 13:50
Key Lock	OFF
Output Hold	ON Current
Reset Av. Output	Reset
Response Time	
Average Period	
Backlight Timer	ON 5 min
Contrast	
To Maintenance Mode	0000

3) Press the  key in a state ON/OFF is highlighted, and “Current” or “Setting” is highlighted. Select “Current” or “Setting” by pressing the  or the  key.

  () 

Parameter	Select Hold ON or OFF
Current Time	05/01/27 THU 13:50
Key Lock	OFF
Output Hold	ON Setting
Reset Av. Output	Reset
Response Time	
Average Period	
Backlight Timer	ON 5 min
Contrast	
To Maintenance Mode	0000

4) Press the  key while “Current” is selected to return to (1). Press the  key while “Setting” is selected to go to the setting entering screen.
 “Current”: Holds the value immediately before the hold.
 “Setting”: Holds the value arbitrarily set.

FB_7_5.ai

- 5) On the parameter hold screen that appears, move the cursor next to the Ch (component) you want to make the setting by pressing the or the key, and then press the key.

↓ ()

Parameter Hold	Select Ch No.		
<input checked="" type="checkbox"/> Ch1	NOx	010	%FS
Ch2	SO ₂	020	%FS
Ch3	CO ₂	015	%FS
Ch4	CO	012	%FS
Ch5	O ₂	022	%FS

- 6) The value is highlighted, indicating that the value can be changed. Change the value by pressing the or the key, and then move the cursor to the right by pressing the key.
- 7) After the value is changed, press the key.

↓ ()

Parameter Hold	Set hold value 0 to 100%FS		
Ch1	NOx	<input type="text" value="010"/>	%FS
Ch2	SO ₂	020	%FS
Ch3	CO ₂	015	%FS
Ch4	CO	012	%FS
Ch5	O ₂	022	%FS

Meaning of setting

The setting is expressed in % against the range for both ranges.
 When 0 to 1000 ppm is selected as the range, for example, if 10% FS is selected as hold setting, the output equivalent to 100 ppm is output and held irrespective of the measurement value at that time.

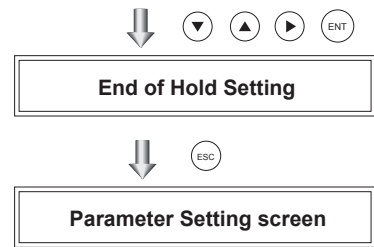

- 8) Press the key to return to the parameter setting screen.

Description of setting

- Instantaneous value display of the measurement cannot be held. (Output only can be held.)
- If set value is selected for hold, instantaneous O₂ correction value is calculated and held based on the set value.
- Range identification contact output cannot be switched even if the range is switched during the hold.

Average value reset

This mode is used to clear all average values O₂ correction average and O₂ average, and restarts averaging. All average values are reset at a time. The indication value and output value is 0 ppm, vol% or so at the time of the reset input (Refer to the average period).

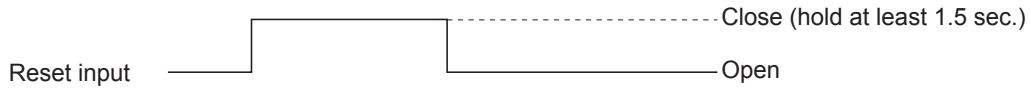

F6_7graph.ai

So long as close, resetting lasts.

At the edge of changing from closing to opening, the average action restarts.

Response time

The response time of the electrical system can be changed.

Setting is available by components.

Note) It does not provide exact seconds for the setting time, but it gives a guide of the setting time.
The setting value can be modified as requested by the customer.

Parameter	Select Ch No.		
Response Time			
<input checked="" type="checkbox"/> Ch1	NO _x	10	sec.
Ch2	SO ₂	20	sec.
Ch3	CO ₂	15	sec.
Ch4	CO	12	sec.
Ch5	O ₂	22	sec.

F6_7_7.ai

Average period

It allows you to set an average period of the average value of O₂ correction and O₂ average. It enables you to set an average time of 1 to 59 minutes (1-minute step) or 1 to 4 hours (1-hour step).

Changing the setting resets the average value of O₂ correction and O₂ average value.

(Pressing the **ENT** validates the resetting only for components whose setting was changed.)

Parameter	Select Ch No.		
Average Period			
<input checked="" type="checkbox"/> Ch9	$\frac{\%}{\text{cu}}$ NO _x	01	hour
Ch10	$\frac{\%}{\text{cu}}$ SO ₂	01	hour
Ch11	$\frac{\%}{\text{cu}}$ CO ₂	01	hour
Ch12	$\%$ O ₂	01	hour

F6_7_8.ai

Example of average action

In case the average period was set to 1 hour.

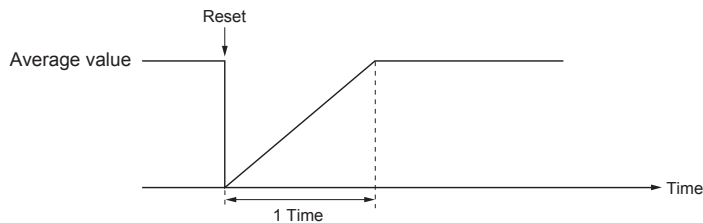



F6_7graph2.ai

- Sampling occurs every 30 seconds.
- Every 30 seconds, the average for last 1 hour (time setting) is output.
- At the instant of resetting, zero is assumed for all past values. It means that the average value will not be correct for 1 hour after resetting.

Backlight Timer

Automatic OFF setting of the backlight of the LCD unit can be made.

When the specified time elapses from when the measurement screen is resumed, the backlight is automatically turned off. Press any key to reset backlight OFF.

Only when ON is selected, the time until auto OFF is displayed. Press the  key in this state, and the time setting can be changed by pressing the  or the  key.

Press the  key to confirm the selection.

If OFF is selected, the backlight is not turned off.

Parameter	Set Backlight Timer ON or OFF
Current Time	05/01/27 THU 13:50
Key Lock	OFF
Output Hold	ON Previous value
Reset Av. Output	Reset
Response Time	
Average Period	
Backlight Timer	<input checked="" type="checkbox"/> ON 5 min
Contrast	
To Maintenance Mode	0000





F8_7graph3.a1

Maintenance mode

Enter the password and then press the  key to enter the maintenance mode. The password can be set by the password setting in maintenance mode. Default password setting at the time of delivery from the factory is "0000." You can enter the maintenance mode with the value before it is changed.

5.8 Maintenance mode

This mode is used for check of sensor input values, display of error log files or setting of passwords, etc. First, enter a password and then use it from the next operation. This mode is displayed by selecting the Maintenance Mode from “Item 6.7 Parameter Setting”.

- (1) Select the Maintenance mode from the Parameter Setting screen to display the Password Setting screen.
 - (2) Enter the password, and the Maintenance Mode item selection screen will be displayed. Point the cursor to the item you want to set by pressing the  or  key and press the  key.
 - (3) Next, each Maintenance screen is displayed.
- Note)** “To Factory Mode” is used for our service engineers only. Refrain from using this mode.
- (4) Press the  key to return to the Maintenance Mode item selection screen from each screen.

Maintenance Mode	Select operating item
<input checked="" type="checkbox"/> 1. Sensor Input Value 2. Error Log 3. Cal. Log 4. Optical Adjustment 5. Interference Compensation Adj. 6. Output Adj. 7. Other Parameter 8. To Factory Mode	



Each “Maintenance” screen

Description of Sensor Input Value screen

- NO_x M : NO_x sensor input value
- NO_x C : NO_x interference compensation sensor input value
- SO₂ M : SO₂ sensor input value
- SO₂ C : SO₂ interference compensation sensor input value
- CO₂ M : CO₂ sensor input value
- CO₂ C : CO₂ interference compensation sensor input value
- CO M : CO sensor input value
- CO C : CO interference compensation sensor input value
- Temperature: temperature sensor input value
- O₂ : O₂ sensor input value

Maintenance Sensor Input			
	sensor	input	
	NO _x M	648	02
	C	499	TEMP
	SO ₂ M	1518	Press.
	C	425	
	CO ₂ M	1120	
	C	80	
	CO M	39	
	C	80	

Maintenance Error Log		ENT : Clear Error Log ESC : Back					
error No.	YY	MM	DD	HH	MM	Ch	
No. 4	04	2	11	18	10	5	
No. 1	04	1	10	12	2	1	
No. 6	03	12	1	10	10	2	
No. 9	03	12	1	10	10	2	
No. 5	03	12	1	0	0	2	
No. 9	03	12	1	0	0	2	
▼ Next page						Page 1	
<input checked="" type="checkbox"/> Clear Error Log							

• Error Log screen

Description of Error Log screen

Error history. Fourteen newest errors are logged. For error number, date and time (year, month, day, period) of occurrence, channel and other details of error, refer to Item 8.1 Error message. Select Clear Error Log and press the  key, and the error log is cleared completely.

• Calibration Log screen

Description of Calibration Log screen

Past calibration history.
 Sensor input value, concentration value, and the date when zero/span calibration is performed are logged. The 10 newest calibration data is logged by each component.
 Move the cursor to Clear Calibration Log and press the **ENT** key, and the calibration log is cleared completely.

- Z1 : Zero calibration (Z) of Range 1
- S1 : Span calibration (S) of Range 1
- M : Value of measuring detector at the time of calibration
- C : Value of the interference compensation detector at the time of calibration
- Con : Concentration value displayed before calibration

Maintenance Mode Cal. Log	Select Ch No.
<input checked="" type="checkbox"/> Ch1 NOx Ch2 SO2 Ch3 CO2 Ch4 CO Ch5 O2	
Clear Cal. Log	



Maintenance Cal. Log Ch1 NOx				
R	M	C	Con	M D H M
Z1	00023	00045	-0.2	12111810
S1	05439	01254	189.5	12111810

FB_8_1.ai

Caution

If the following operation is maladjusted, the measurement may be adversely and excessively affected. Carry out the operation with utmost attention.

• Optical adjustment screen

For details of this item, refer to "Item 7.3.3 Optical zero adjustment method".

Press **ENT** key and turn ON the solenoid valve signal for each calibration gas by using the **▲** or **▼** key.

Maintenance Optical Adj.	ENT : Selectable flow gas		
1-1	9 3	2-1	24 1
1-2	21 27	2-2	40 80
<input checked="" type="checkbox"/> GAS Sample			





FB_8gamen.ai



• Moisture interference adjustment screen

For details of this item, refer to “Item 7.3.4 Moisture interference adjustment method.”

Description of moisture interference adjustment screen

In values on the left side of screen, the moisture interference for each component is already offset. The figures at right are interference compensation coefficients.

Move the  cursor to a desired Ch (component) by pressing the  or the  key, and then press the  key, and the selected value at right is highlighted.

Check that the gas for moisture interference compensation is flowing, change the moisture interference compensation coefficient using the  or the  key, adjust the value at left so that it becomes near zero, and then press the  key to log moisture interference compensation value.

Caution

Since an interference compensation detector is not provided if the 1st range is beyond 0 to 10 vol%, no interference adjustment can be performed (no need).

Maintenance	Select Ch No. ENT : Entry ESC : Back		
 Ch1	NO _x	10	1.252
Ch2	SO ₂	-33	0.983
Ch3	CO ₂	13	0.000
Ch4	CO	20	1.922
ALL			
Valve OFF			











Maintenance	Adjust with UP / DOWN ENT : Memorized ESC : Back		
Ch1	NO _x	0	1.26 
Ch2	SO ₂	-33	0.983
Ch3	CO ₂	13	0.000
Ch4	CO	20	1.922
ALL			
Valve OFF			

F6_8_2.ai

• Output adjustment screen

Description of output adjustment screen

Analog output adjustment screen.
 Connect the digital multi meter to the output terminal corresponding to the number of OUT to be adjusted, and adjust the value so that 4 mA or 0 V is output at zero and 20 mA or 1 V is output at span.

Move the cursor using the , , or the  key to the output (OUT No. and zero/ span) to be adjusted, and then press the  key. The selected value is highlighted.
 Adjust the value, while watching the output, by pressing the  or the  key.
 Press the  key to select the next digit.
 On completion of the adjustment, press the  key.

Maintenance Mode Output Adj.			Adjust OUTPUT ZERO and SPAN		
OUT	ZERO	SPAN	OUT	ZERO	SPAN
1	01245	11845	7	01900	12500
2	01245	11845	8	01900	12500
3	01245	11845	9	01900	12500
4	01245	11845	10	01900	12500
5	01245	11845	11	01900	12500
6	01245	11845	12	01900	12500



Maintenance Mode Output Adj.			Adjust OUPUT ZERO and SPAN		
OUT	ZERO	SPAN	OUT	ZERO	SPAN
1	0124 5	11845	7	01900	12500
2	01245	11845	8	01900	12500
3	01245	11845	9	01900	12500
4	01245	11845	10	01900	12500
5	01245	11845	11	01900	12500
6	01245	11845	12	01900	12500

F6_9_3.a

• Other parameter

Description of each setting screen

Password Set : Set the password used to move from the parameter setting screen to the maintenance mode. Arbitrary 4-digit number can be selected.

O₂ ref. Value: Set the oxygen concentration reference value at the time of oxygen correction calculation. Settable in the range from 00 to 19% (default 4%).

Limit : Set the oxygen concentration limit at the time of oxygen correction calculation. Settable in the range from 01 to 20% (default 17%).



* Refer to the O₂ correction concentration value in "5.3 Outline of display screen" for oxygen correction calculation procedure.

Station No. : Set the station No. for MODBUS communication. Settable in the range from 00 to 32.



Range setting : Moves to the screen on which measuring range is changed.

Maintenance Mode setting	Set Password
Password Set	465
O ₂ ref. Value	4% O ₂ limit 17% O ₂
Station No. 01	
Range setting	

FB_Bgamen_2.ai

Press the  or the  key to move the cursor to the item whose setting is to be changed.

The values for password, oxygen correction, limit, and station No. are highlighted.

Press the  or the  key to change the value to desired one, and then press the  key.

Note: Pay attention not to forget the password. Otherwise you cannot enter the maintenance mode.

<How to set/change the range>

The measuring range can be arbitrarily selected in the minimum and the maximum range specified at the time of purchase. The range to be used can be selected 1 or 2.

- (1) Move the cursor to the item to be set by pressing the or the key, and then press the key.

- (2) Move the cursor to the Ch (component) whose setting is to be changed by pressing the or the key, and then press the key.

- (3) Move the cursor to the item whose setting is to be changed by pressing the or the key, and then press the key.

Settable range
 The value for range 1 and range 2 must fall within the range from the MIN and the MAX range (including the MIN and the MAX range), and at the same time range 1 must be smaller than range 2.
 The number of ranges is 1 or 2.

- (4) Press the or the key to change the value. Press the key to select the next digit. In a state where the decimal point is highlighted, press the or the key, and the decimal point position can be changed.

- (5) When necessary change is made, press the .

Maintenance Mode setting	Select operating item
Password set 2465 O2 ref. Value 4% O2 limit 17% O2 Station No.01 <input checked="" type="checkbox"/> Range setting	

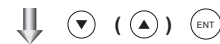

Maintenance Mode Range Set	Select Ch No.
<input checked="" type="checkbox"/> Ch1 NOx Ch2 SO2 Ch3 CO2 Ch4 CO Ch5 O2	

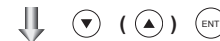

Maintenance Mode Range Set Ch1 NOx	Select range or range num.
MIN range 100.0 ppm Range 1 500.0 ppm Range 2 1000. ppm <input checked="" type="checkbox"/> MAX range 2000. ppm Range num. 2	



Maintenance Mode Range Set Ch1 NOx	Set range
MIN range 100.0 ppm Range 1 5 00.0 ppm Range 2 1000. ppm MAX range 2000. ppm Range num. 2	



End of Set/Change the Range

FB_8_4.a1

5.9 Calibration

5.9.1 Zero calibration

It is used for zero point adjustment. For zero calibration, gas suited for an application should be used according to “(3) Standard gas in Item 3.3 Sampling.”

- Press the **ZERO** key on the Measurement screen to display the Manual Zero Calibration screen.

- Select the Ch (component) to be calibrated by pressing the **▲** or the **▼** key.

After selection, press the **ENT** key, and zero gas will be supplied.

Caution

For the Ch (components) that is set to “both” in the “Zero Calibration” of the Calibration Setting mode, zero calibration is also carried out at the same time.

- Wait until the indication is stabilized with the zero gas supplied. After the indication has been stabilized, press the **ENT** key. Zero calibration in range selected by the cursor is carried out.

Note: For the Ch (component) for which “AR” is selected in “6.1.1 Setting range switch mode,” the cursor automatically moves to the range selected in “Setting of auto calibration component/range” (6.2.4), and calibration is carried out within that range.

To close “Zero Calibration”

To close the “Zero Calibration” or cancel this mode midway, press the **ESC** key. A previous screen will return.

↓ **ZERO**

ZERO Cal.		Select Ch No. with UP / DOWN and ENT Back with ESC	
▶ Ch1 NO _x	▶ Range1 0-100 ppm Range2 0-2000 ppm	0.0	
Ch2 SO ₂	▶ Range1 0-100 ppm Range2 0-2000 ppm	0.0	
Ch3 CO ₂	▶ Range1 0-10 vol% Range2 0-20 vol%	0.00	
Ch4 CO	▶ Range1 0-100 ppm Range2 0-2000 ppm	0.0	
Ch5 O ₂	▶ Range1 0-10 vol% ▶ Range2 0-25 vol%		20.09

↓ **▼** **▲** **ENT**

ZERO Cal.		Select Ch No. with UP / DOWN and ENT Back with ESC	
Ch1 NO _x	▶ Range1 0-100 ppm Range2 0-2000 ppm	0.0	
▶ Ch2 SO ₂	▶ Range1 0-100 ppm Range2 0-2000 ppm	0.0	
Ch3 CO ₂	▶ Range1 0-10 vol% Range2 0-20 vol%	0.00	
Ch4 CO	▶ Range1 0-100 ppm Range2 0-2000 ppm	0.0	
Ch5 O ₂	▶ Range1 0-10 vol% ▶ Range2 0-25 vol%		20.09

↓ **▼** **(▲)** **ENT**

ZERO Cal.		ENT : Go on calibration of selected Ch ESC : Not calibration	
Ch1 NO _x	▶ Range1 0-100 ppm Range2 0-2000 ppm	▶ 0.0	
Ch2 SO ₂	▶ Range1 0-100 ppm Range2 0-2000 ppm	▶ 0.9	
Ch3 CO ₂	▶ Range1 0-10 vol% Range2 0-20 vol%	▶ 0.34	
Ch4 CO	▶ Range1 0-100 ppm Range2 0-2000 ppm	▶ 1.1	
Ch5 O ₂	▶ Range1 0-10 vol% ▶ Range2 0-25 vol%	▶ 20.09	

FB_9_1-08

↓ **ENT**

**To Measurement screen after
executing Manual Zero Calibration**

5.9.2 Span calibration

It is used to perform a span point adjustment. Supply calibration gas with concentration set to the span value to perform the span calibration. For the span calibration gas for the NO_x, SO₂, CO₂, CO measurement, use the standard gas with a concentration of 90% or more of the range value. For the span calibration gas for the O₂ measurement, use the standard gas with a concentration of 90% or more of the range value when measuring with the built-in O₂ sensor, and use the standard gas of 1 to 2 vol% when measuring with an external zirconia O₂ sensor.

- (1) Press the **SPAN** key on the Measurement screen to display the Manual Span Calibration screen.

↓ **SPAN**

SPAN Cal.		Select Ch No. with UP / DOWN and ENT Back with ESC	
▶ Ch1 NO _x	▶ Range1 0-100 ppm Range2 0-2000 ppm		0.0
Ch2 SO ₂	▶ Range1 0-100 ppm Range2 0-2000 ppm		0.0
Ch3 CO ₂	▶ Range1 0-10 vol% Range2 0-20 vol%		0.00
Ch4 CO	▶ Range1 0-100 ppm Range2 0-2000 ppm		0.0
Ch5 O ₂	▶ Range1 0-10 vol% ▶ Range2 0-25 vol%		20.09

- (2) Select Ch (component) to be calibrated by pressing the **▲** or **▼** key and press the **ENT** key. The calibration gas is supplied.

↓ **▼** (**▲**) **ENT**

SPAN Cal.		Select Ch No. with UP / DOWN and ENT Back with ESC	
Ch1 NO _x	▶ Range1 0-100 ppm Range2 0-2000 ppm		0.0
▶ Ch2 SO ₂	▶ Range1 0-100 ppm Range2 0-2000 ppm		0.0
Ch3 CO ₂	▶ Range1 0-10 vol% Range2 0-20 vol%		0.00
Ch4 CO	▶ Range1 0-100 ppm Range2 0-2000 ppm		0.0
Ch5 O ₂	▶ Range1 0-10 vol% ▶ Range2 0-25 vol%		20.09

Caution

When “both” from “Calibration Range” of the Calibration Setting mode is set, span calibration is performed together with 2 Ranges.

- (3) Wait until the indication is stabilized in the state where the calibration gas is supplied. After the indication has been stabilized, press the **ENT** key. Span calibration of Range selected by the cursor is performed.

Note: For the Ch (component) for which “AR” is selected in “6.1.1 Setting range switch mode,” the cursor automatically moves to the range selected in “Setting of auto calibration component/range” (6.2.4), and calibration is carried out within that range.

↓ **▼** (**▲**) **ENT**

SPAN Cal.		ENT : Go on calibration of selected Ch ESC : Not calibration	
Ch1 NO _x	▶ Range1 0-100 ppm Range2 0-2000 ppm		0.0
Ch2 SO ₂	▶ Range1 0-100 ppm Range2 0-2000 ppm	▶	0.9
Ch3 CO ₂	▶ Range1 0-10 vol% Range2 0-20 vol%		0.34
Ch4 CO	▶ Range1 0-100 ppm Range2 0-2000 ppm		1.1
Ch5 O ₂	▶ Range1 0-10 vol% ▶ Range2 0-25 vol%		20.09

To close “Span Calibration”
To close the “Span Calibration” or cancel this mode midway, press the **ESC** key. A previous screen will return.

To Measurement screen after executing Manual Span Calibration

6. MAINTENANCE

WARNING

Purge not only inside of IR400 but all measuring gas lines with zero gas sufficiently, when you provide maintenance or inspection on IR400 with its cover or door open. Otherwise it may cause hazardous accidents such as gas leakage, fire and explosion.

CAUTION

Do not operate the analyzer for a long time with its cover or door left open. Otherwise, dust, foreign matter, etc. may stick on internal walls, thereby causing faults.

6.1 Daily check

(1) Zero calibration and span calibration

1. Perform zero calibration. For the calibration procedures, refer to “Item 6.9.1 Zero calibration”.
2. Then, perform span calibration. For the calibration procedures, refer to “Item 6.9.2 Span calibration”.
3. Zero calibration and span calibration should be carried out once a week, as required.

(2) Flow rate check

1. Sampling gas flow and purge gas flow are as follows:
 - Sampling gas flow: 0.5 ± 0.2 L/min
 - Purge gas flow: About 1 L/min
2. Check and maintenance should be carried out every day, as required.

6.2 Daily check and maintenance procedures

Table 7.1 Maintenance and check table

	Parts to be checked	Phenomena	Causes	Remedy
Daily check	Indication value	Indication values are lower. Indication values are higher.	(1) Dust is mixed in sampling cell (2) Air is absorbed midway in the sampling pipe.	(1) Clean the sampling cell. In addition, check sampling devices, especially gas filter. (2) Find out cause of leak and repair.
	Purge gas flow is included when purging gas in sample gas flow rate.	Standard flow is beyond the specified flow rate of 0.5 L/min, 0.3 to 0.7 L/min.		Adjust be needle valve of flow rater.
Weekly check	Zero point of gas analyzer	It is deflected.	_____	Adjust.
	Span point of gas analyzer	It is deflected.	_____	Adjust.
Yearly check	Gas analyzer	Regardless of any phenomena	_____	Overhaul.

6.3 Maintenance of analyzer unit

6.3.1 Cleaning method for sample cell (pipe cell)

This section is strictly factory adjusted. Handle it with utmost attention.
If it is absolutely required, contact us.

- (1) Turn off the power switch, stop the sample gas, and allow the zero gas to flow for several minutes to purge the cell interior.

Loosen the setscrew (2 pieces) from the top cover and remove it.
- (2) Remove the internal gas inlet tube.
- (3) Loosen both right and left screws for cell holding plate.
 - Remove the sample cell only.
- (4) Turn to the left the sample cell window and remove it from the sample cell (see Fig. 6-1).
- (5) For cleaning the window and cell inside surface, first eliminate coarse dust by soft brush or the like and then wipe them by soft rag.
The window is easy to get scratched.
Pay utmost attention so as not to damage it.

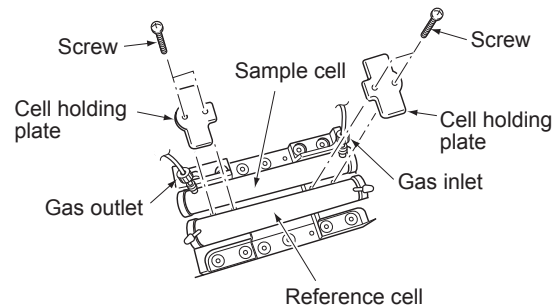
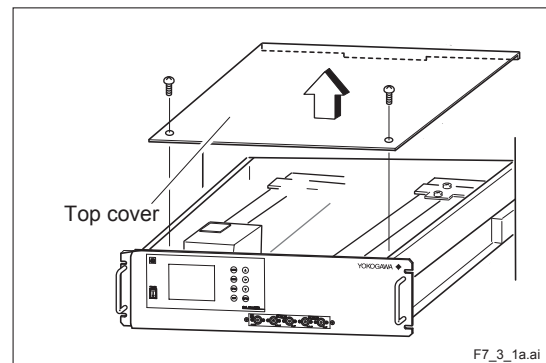

F7 3 1E 1.ai

- (6) After the end of sample cell cleaning, mount the cell in place and proceed to running. After cleaning sample cell, be sure to perform optical zero adjustment (see Item 6.3.3) and moisture interference compensation adjustment (see Item 6.3.4).

! WARNING

If the window or the cell interior is very dirty, use a soft cloth moistened with absolute alcohol. A slightly corroded infrared transmission window or sample cell can be remedied by gently rubbing with chromium oxide powder on cleaning cloth but an excessively corroded one must be replaced. When cleaning, do not exert an excessive stress.

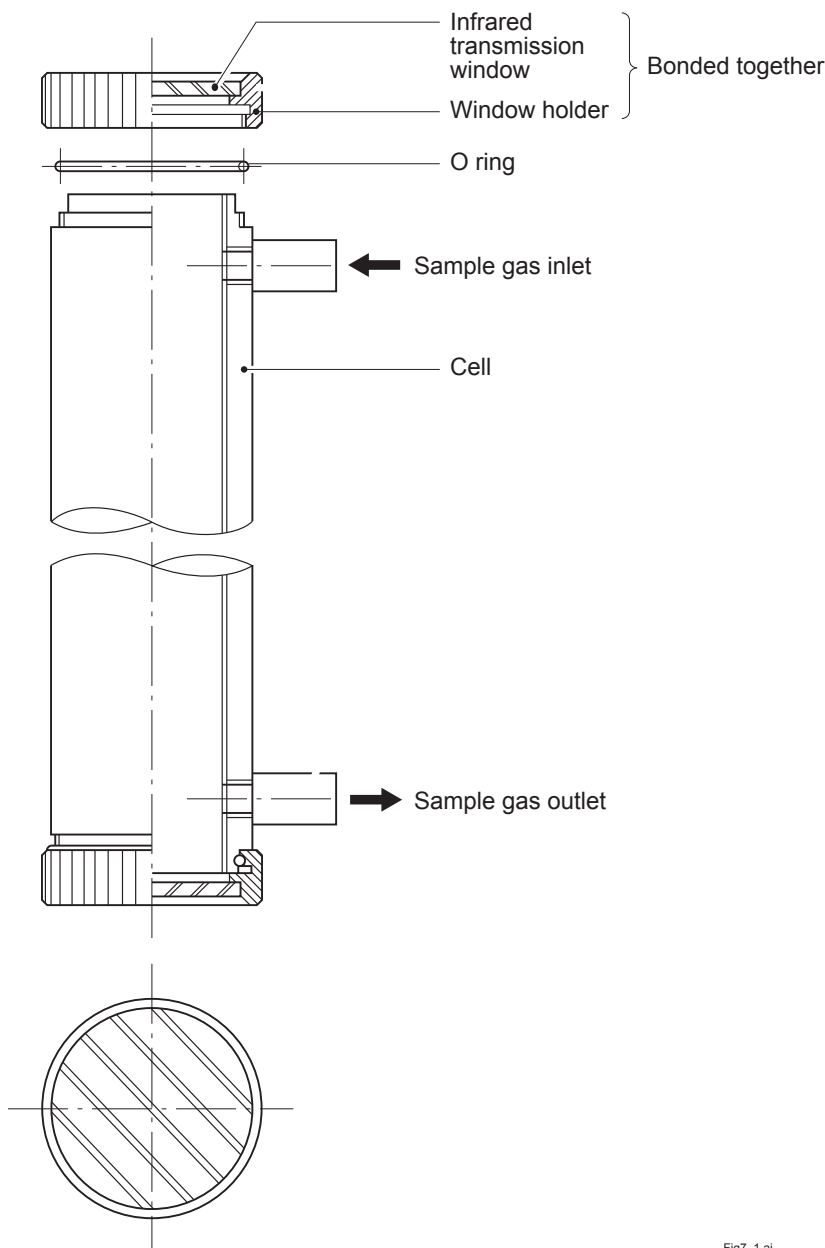

Fig. 6-1 Structure of sample cell (pipe cell)

Fig7_1.ai

6.3.2 Cleaning method for sample cell (block cell)

- (1) Turn off the power switch, stop the sample gas, and allow the zero gas to flow for several minutes to purge the cell interior.

Loosen the setscrew (2 pieces) from the top cover and remove it.

- (2) Remove the internal gas inlet tube.
- (3) Loosen the 2 detector set bolts.

Note) The distribution cell, block cell and detector are fastened by the same bolts.

- (4) Using the furnished cell mounting tool, turn the window fixture to the left and remove it from the cell. (See the structure of sample cell (block cell) in Fig. 6-2.)
- (5) For cleaning the infrared transmission window and cell inside surface, first eliminate coarse dust by soft brush or the like and then wipe them by soft rag. The window is easy to get scratched. Pay utmost attention so as not to damage it.
- (6) After the end of sample cell cleaning, mount the cell in place and proceed to running.

After cleaning sample cell, be sure to perform optical zero adjustment (see Item 6.3.3) and moisture interference compensation adjustment (see Item 6.3.4).

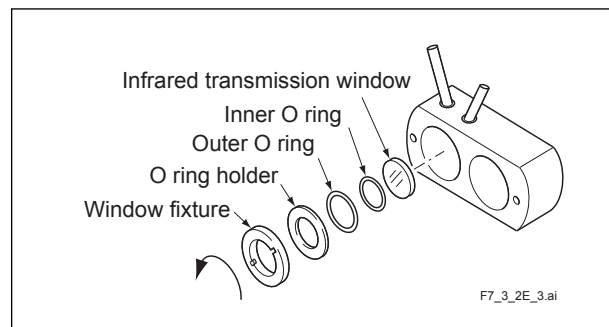
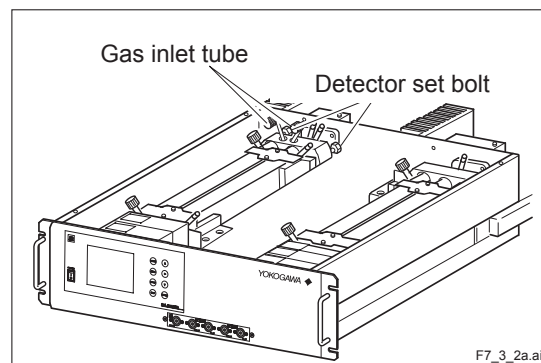
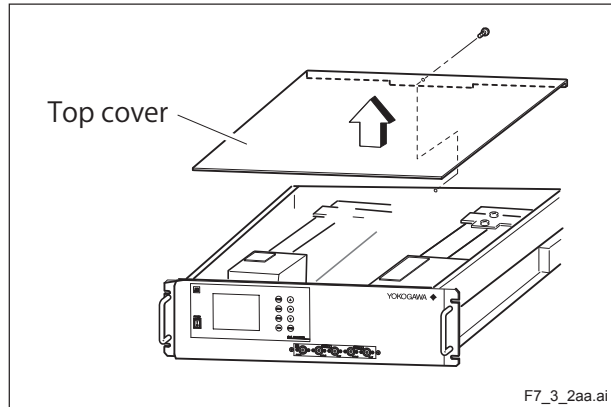

WARNING

If the window or the cell interior is very dirty, use a soft cloth moistened with absolute alcohol. A slightly corroded infrared transmission window or sample cell can be remedied by gently rubbing with chromium oxide powder on cleaning cloth but an excessively corroded one must be replaced. When cleaning, do not exert an excessive stress.

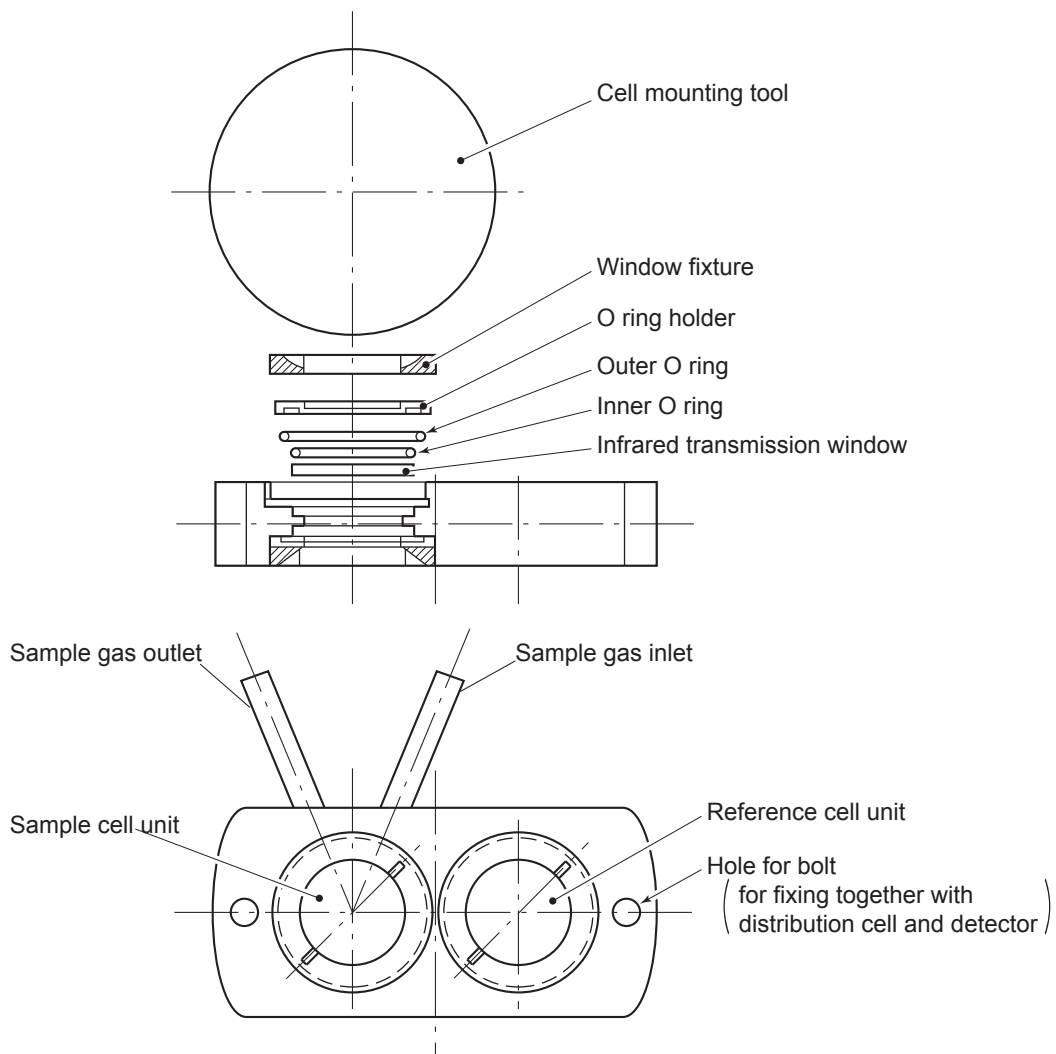

Structure of sample cell (of 32, 16, 8, 4, 2 mm long)
(sample cell and reference cell are integrated)

Note) Use the dedicated cell mounting tool (furnished).

Fig7_2.ai

Fig. 6-2 Structure of sample cell (block cell)

6.3.3 Optical zero adjustment method (optical balance adjustment)

! WARNING

If the following operation is maladjusted, the measurement may adversely be affected. If you are not trained for adjustment, do not carry out this operation but contact the distributor or our serviceman.

The adjustment is performed at reassembly after removing the sample cell or other parts for cleaning, etc.

- (1) Remove the top cover. Allow dry N₂ or air to flow through the analyzer unit sample gas inlet until the reading stabilizes. The sample gas is introduced directly to the INLET of analyzer unit through the gas cylinder.
- (2) Proceed to an optical adjustment in the maintenance mode. The display on the operation panel of the main unit is as illustrated on the right. Balance adjustment is not required if the display falls within ±100.

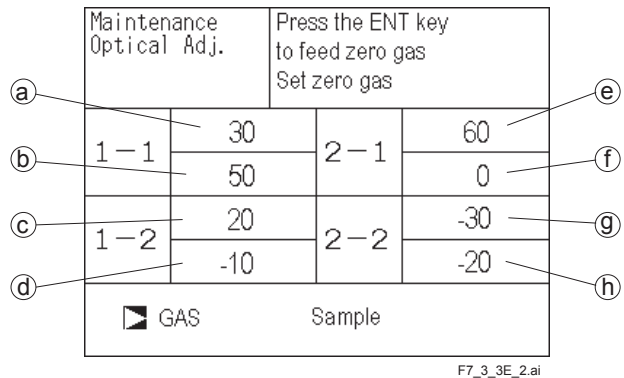
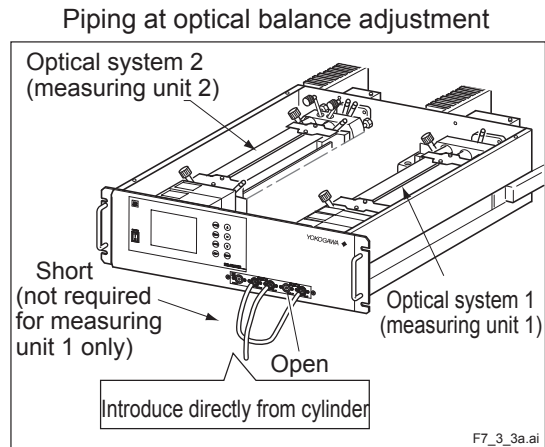

<Correspondence between measurement detector and indicated position>

No. of components to be measured		a	b	c	d	e	f	g	h
1-component meter		Main	Comp	—	—	—	—	—	—
2-component meter	NO-SO ₂	NO Main	NO Comp	SO ₂ Main	SO ₂ Comp	—	—	—	—
	CO ₂ -CO	CO ₂ Main	CO ₂ Comp	CO Main	CO Comp	—	—	—	—
	NO-CO	NO Main	NO Comp	—	—	CO Main	CO Comp	—	—
3-component meter NO-SO ₂ -CO		NO Main	NO Comp	SO ₂ Main	SO ₂ Comp	CO Main	CO Comp	—	—
4-component meter NO-SO ₂ -CO ₂ -CO		NO Main	NO Comp	SO ₂ Main	SO ₂ Comp	CO ₂ Main	—	CO Main	CO Comp

* O₂ is excluded from the number of components.
 * Main is signal input value from the main detector of each component.
 Comp is signal input value from interference compensation detector of each component.
 If low range exceeds the range of 0 to 10 vol%, detector signal of comp is not usable.
 Sensor values of which are not included in measuring components should be ignored.

- (3) Carry out the adjustment in the procedure in (4) and subsequent.
 - Adjust on the primary side of the optical system so that the values for (a) to (d) in 1-1 and 1-2 become as close to 0 as possible within ± 100 range.
 - Adjust on the secondary side of the optical system so that the values for (e) to (h) in 2-1 and 2-2 become as close to 0 as possible within ± 100 range.
- (4) Operate the optical zero adjustment knob to change the value displayed at (a) or (e).
- (5) Move the dimmer plate side view to change the value displayed at (b) or (f).
- (6) Move the dimmer plate sidewise to change the value displayed at (c) or (g).
- (7) Move the dimmer plate sidewise to change the value displayed at (d) or (h).
- (8) Repeat the procedures in (4) to (7) to make all the displayed values come close to 0 as possible within ± 100 range.
 - * Adjust the dimmer plate which is the nearest the zero adjustment knob first, and sequentially.
- (9) After the optical balance adjustment, mount the top cover of the analyzer unit, then carry out a moisture interference compensation adjustment, and perform zero and span calibrations.
 - * Before moving the dimmer plate, loosen the detector set bolts (just enough to make the plate movable for snug adjustment).

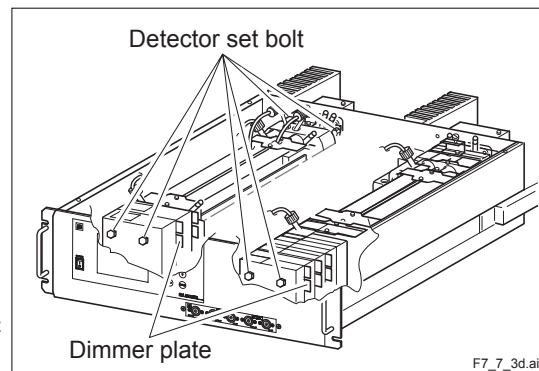
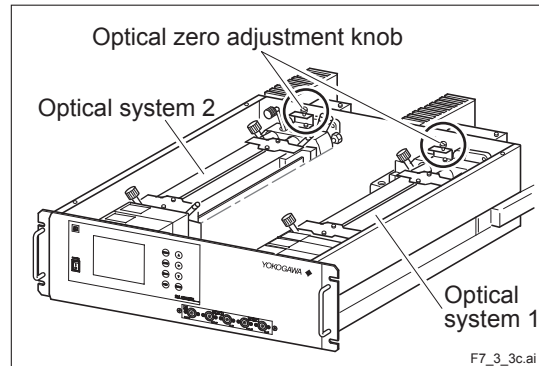

6.3.4 Moisture interference compensation adjustment method

WARNING

If the following operation is maladjusted, the measurement may adversely be affected. If you are not trained for adjustment, do not carry out this operation but contact the distributor or our sales personell.

Proceed to an adjustment if excessively (beyond $\pm 2\%$ FS) affected by moisture interference.

After the end of optical balance adjustment, be sure to carry out moisture interference compensation adjustment.

- (1) After warm-up, select the low range, allow dry gas (N_2 , air) to flow at 0.5 L/min and carry out zero calibration.
- (2) Display the moisture interference compensation screen of the analyzer unit (see "5.8 Maintenance mode"). Set the dew point to $2^\circ C$ by using an electronic cooler, and introduce bubbled N_2 or air gas to the analyzer (See the right-hand side figure).

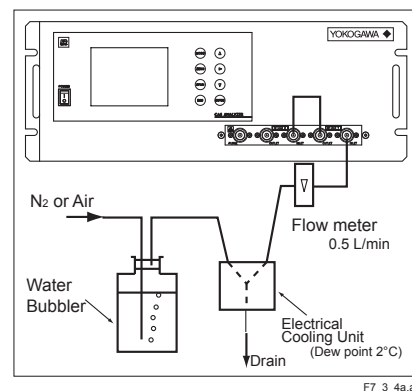

- (3) On the screen, select a desired Ch (component) by pressing the **ENT** key, adjust the value at right by pressing the **▲** or the **▼** key so that the value at left falls within ± 10 (make it as close to 0 as possible), and then press the **ENT** key to memorize the value. (Exiting by “**ENT**” cancels the adjustment.)

Or, selecting the “ALL” and pressing the “**ENT**” key, zeroes all components integrally.

(First, adjust all components by selecting ALL and then perform fine adjustment for components one by one using **▲** and **▼** keys.)

* If any components exceed the range of 0 to 10 vol%, no adjustment can be performed (No interference compensation is required).

Moisture interference Compensation Adj.		Select Ch No. with UP / DOWN and ENT Back with ESC	
Ch1	NO _x	10	1.252
Ch2	SO ₂	-33	0.983
Ch3	CO ₂	13	0.000
Ch4	CO	20	1.922
ALL			
Valve OFF			

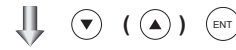

Moisture interference Compensation Adj.		Adjust with UP / DOWN ENT : Memorized ESC : Back	
Ch1	NO _x	10	1.252
Ch2	SO ₂	-33	0.983
Ch3	CO ₂	13	0.000
Ch4	CO	20	1.922
ALL			
Valve OFF			

F7_3_4E_1.ai

6.3.5 Replacement of fuse on analyzer unit

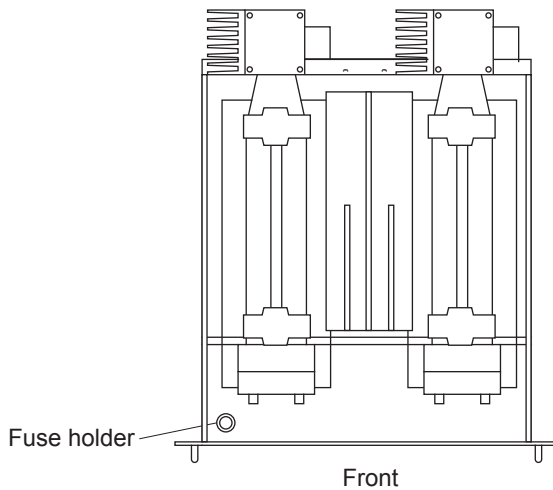

Fig7_3.ai

Fig. 6-3

Note: Before the following work, be sure to remove the cause of blown fuse (short, etc) and repair.

- (1) Turn OFF the main power supply SW of the analyzer.
- (2) Loosen setscrews (4 pcs.) from the top of the analyzer and remove the top cover.
- (3) Turn the fuse holder (shown in Fig. 6-3) counterclockwise and put it out, and the cap will be removed. Remove the fuse (250 V AC/3 A) from the holder. Replace it with a new one .
- (4) Mount the fuse holder cap and cover for analyzer indication unit in the reverse procedure. Turn ON the power supply SW. The work will be completed if the analyzer works normally.

6.4 Inspection and maintenance of limited service-life components

The analyzer uses limited-life components. The recommended replacement periods are listed in the below table.

- (1) Limited service-life components are those which wear out or for which failure is presumed within five years under normal operating or storage conditions. Components with more than five years of service life are the exception.
- (2) The following table only involves the recommended periods for conducting preventive maintenance for limited service-life components; these periods do not guarantee that accidental failures will not occur.
- (3) The recommended replacement periods are tentative and depend on operating conditions.
- (4) The recommended replacement periods may vary depending on the field date.

Checkpoint	Check and maintenance items	Procedure and criteria	Recommended check and maintenance periods							
			Routine	Once a week	Once a month	Every three months	Every six months	Once a year	Every two years	Every five years
Infrared gas analyzer	1. Light source	Recommended replacement period: Every five years (*1)								★
	2. Sector motor	Recommended replacement period: Every two years (*1)								★
	3. Detector without O ₂ sensor	Recommended replacement period: Every five years (*1)								★
	4. O-ring	Recommended replacement period: Every two years, inspect it when cleaning of measuring cell. See Sec. 7.3						○		★
	5. LCD panel	Recommended replacement period: Every five years (*1)								★
	6. Power supply	Recommended replacement period: Every five years (*1)								★
	7. Measuring cell	Set up an appropriate maintenance period (by referring to the check results)				○				
	8. Reference cell	Recommended replacement period: Every five years (*1)								★

(*) In the check and maintenance columns, place a check mark (○) for check and confirmation work, a dark star (★) for replacement, and a white star (☆) for parts preparation for preventive maintenance.

(*1) These are work of service person, contact our service persons.

● Precautions for inspection

- 1) When handling reference gas (during calibration), carefully read the reference-gas instruction manual to use the gas correctly. In particular, special attention must be taken in handling carbon monoxide gases; otherwise, you may suffer from gas poisoning.
- 2) During maintenance checks, be sure to keep the near fan on. If any gas leaks, you may suffer from gas poisoning.
- 3) When replacing the analyzer gas filter or conducting maintenance service of the washer, completely shut the calibration-gas valve. Otherwise, you may suffer from gas poisoning.

7. TROUBLE SHOOTING

7.1 Error message

If errors occur, the following contents are displayed.

Error display	Error contents	Probable causes
Error No.1	Motor rotation detection signal faulty	<ul style="list-style-type: none"> • Motor rotation is faulty or stopped. • Motor rotation detector circuit is faulty. Note) Sector motor is a consumption part. It is recommended to exchange the motor once in two years.
Error No.4	Zero calibration is not within.	<ul style="list-style-type: none"> • Zero gas is not supplied. • Zero is deflected much due to dirty cell. • Detector is faulty. • Optical balance is maladjusted.
Error No.5	Amount of zero calibration (indication value) is over 50% of full scale.	
Error No.6	Span calibration is not within the allowable range.	<ul style="list-style-type: none"> • Span gas is not supplied. • Calibrated concentration setting does not match cylinder concentration. • Zero calibration is not performed normally. • Span is deflected much due to dirty cell. • Detector sensitivity has deteriorated.
Error No.7	Amount of span calibration (difference between indication value and calibrated concentration) is over 50% of full scale.	
Error No.8	Measured values fluctuate too much during zero and span calibration.	<ul style="list-style-type: none"> • Calibration gas is not supplied. • Time for flowing calibration gas is short.
Error No.9	Calibration is abnormal during auto calibration.	<ul style="list-style-type: none"> • Error corresponding to No. 4 to No. 8 occurred during auto calibration.
Error No.10	Output cable connection is improper.	<ul style="list-style-type: none"> • Wiring is detached between analyzer and interface module. • Wiring is disconnected between analyzer and interface module

When errors No. 1 and No. 10 occur, analyzing block error contact output is closed.

When errors No. 4 to No. 9 occurs, calibration error contact output is closed.

Screen display and operation at the occurrence of error

In case of Error No. 1 to No. 4, No. 6, No. 8 to No. 10

Measurement screen

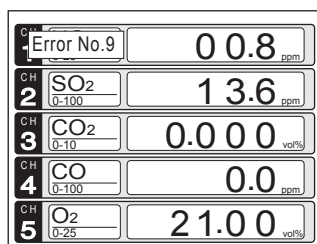

- Press the **ESC** key to delete the error display.
- If the **ESC** key is pressed without removing the cause of an error, the error will be displayed again.

Display of error contents

Error No.9	Auto Cal. error ESC:Back to MEAS.
SPAN NOX Calibration error Cause <ul style="list-style-type: none"> • Calibration gas is not flowing • Gas flowing time is short • Setting conc. is different from gas conc. • Dirt in sample cell 	

- When more than one error occurs, pressing the **▶** key moves to another error display.

Error No. 5 and No. 7

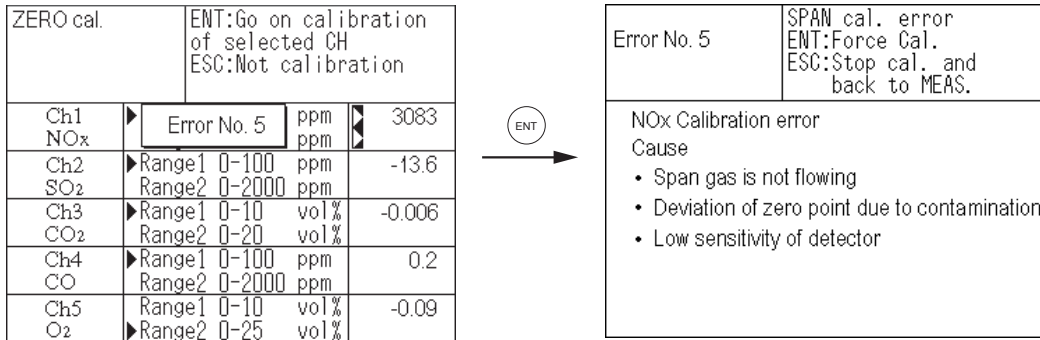

• Pressing (ESC) delete the error display.

(ENT) → Calibrated
forcibly

Calibration is continued. Unless another calibration error occurs, calibration is carried out to the end, the Measurement screen returns.

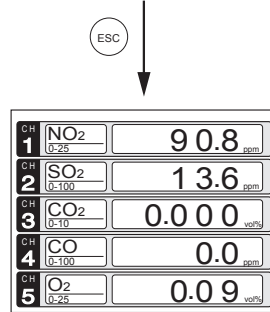

F8_2.ai

Error log file

If error occurs, the history is saved in an error log file. The error log file exists in the maintenance mode.

Error log screen

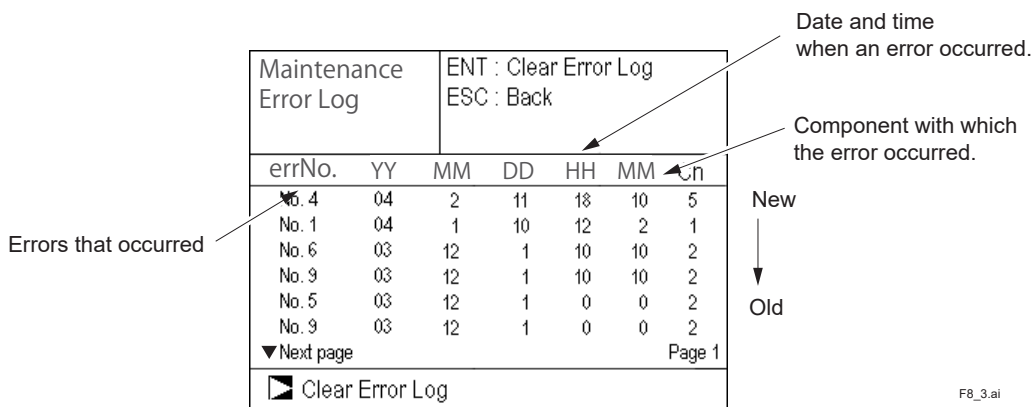

F8_3.ai

* Up to 14 errors can be saved in the error history; the oldest error will be deleted one by one every time a new occurs.
 * If the power supply is turned OFF, the contents in the error log file will not be lost or damaged.

Deletion of error history

Press the (ENT) key on the above screen, and the "Error Log Clear" will be inverted. Further pressing the (ENT) key will clear the error history.

7.2 Troubleshooting

The following table shows how to remedy other troubles, such as faulty readings.

Symptom	Checking Item	Remedy, etc.
Zero calibration fails. Error No. 4, 5, or 8 occurs.	<ul style="list-style-type: none"> • Check if the zero gas is supplied to the analyzer at the specified flow rate. • Check the optical balance. (See Subsection 6.3.3, "Optical zero adjustment method.") • Check the count value on the display panel. (Refer to the sensor input value by maintenance mode.) 	<ul style="list-style-type: none"> • Locate and check gas leaking points, and take the proper remedy. • Adjust the optical balance.
Span calibration fails. Error No. 6, 7, or 8 occurs.	<ul style="list-style-type: none"> • Check if the span gas is supplied to the analyzer at the specified flow rate. • Check if zero calibration can be performed properly. • Check the count value on the display panel. (Refer to the sensor input value by maintenance mode.) 	<ul style="list-style-type: none"> • Locate and check gas leaking points, and take the proper remedy. • If zero calibration fails, first attempt remedies for zero calibration trouble. • Are there any changes from when zero gas is supplied?
Error occurs during auto calibration. Error No. 9 occurs.	<ul style="list-style-type: none"> • Take either of the above remedies depending on the source of the error: zero calibration or span calibration trouble. 	
Drift.	<ul style="list-style-type: none"> • Check if the sample gas is supplied to the analyzer at the specified flow rate. • Check the optical system, e.g., the sample cell window, O-ring, detector window and inside of the cell for heavy dirt. 	<ul style="list-style-type: none"> • Locate and check gas leaking points, and take the proper remedy. (See Section 3.3.) • Clean the cell and window. Replace the part.(See Subsections 6.3.1 and 6.3.2.)
Readings are abnormally high or low.	<ul style="list-style-type: none"> • Check for the influence of interference from moisture. • Check if the sample gas contains interfering components in large quantities or not. 	<ul style="list-style-type: none"> • Adjust interference from moisture. • Investigate the components of the sample gas and then contact our service person.
Readings do not increase.	<ul style="list-style-type: none"> • Check if the sample gas is supplied to the analyzer at the specified flow rate. • Check if the zero and span calibration is enabled. 	<ul style="list-style-type: none"> • Locate and check gas leaking points, and take the proper remedy. (See Section 3.3.) • If enabled, sampling (check the points relating only to the sample gas and take the proper remedy.) • If not enabled, check the calibration related error items.

Customer Maintenance Parts List

Model IR400
Infrared Gas Analyzer

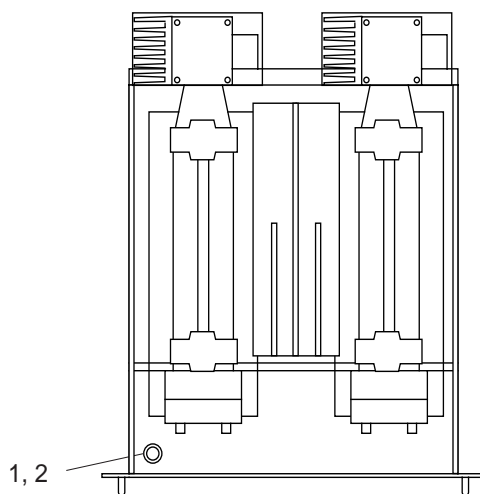

<u>Item</u>	<u>Parts No.</u>	<u>Qty.</u>	<u>Description</u>
1	K9218SB	1	Fuse (Time Lag Fuse)
2	K9358QL	1	Fuse holder

● Pipe Cell

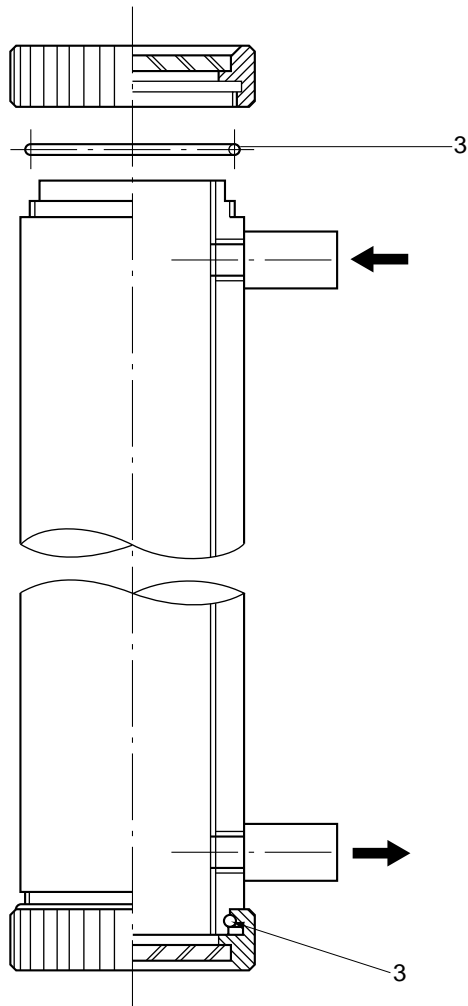

● Block Cell

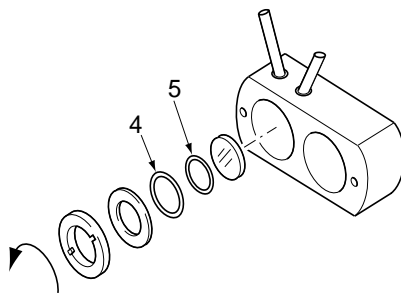

Item	Parts No.	Qty.	Description
3	K9358SD	2	O-ring
4	K9358SQ	1	O-ring (Out-side)
5	K9358SR	1	O-ring (Out-side)

Revision Information

- Title: Model IR400 Infrared Gas Analyzer
- Manual No.: IM 11G02N01-01E

Edition Date Remark (s)

- 9th Oct. 2019**
Revised a figure of the cable for I/O terminal (p.2-14)
- 8th May. 2019**
Revised EMC (p.2-2)
Modified specifications (p.2-2)
Modified Model and Suffix codes (p.2-6, 2-8, 2-9)
Corrections of External Dimensions (p. 2-16)
- 7th May. 2018**
Deleted IR200
Removed the section for ZX8D(2-19 to 2-20)
- 6th Apr. 2018**
Style change from Style 3 to 4.
p.1-2, 1-3, 2-6 to 2-8, 2-10, 2-13, 3-2 to 3-5, 3-10, 4-2, 6-2, 6-4, 6-6, 6-7
EMC, RoHS p.2-2, 2-15, 2-20, 2-21
WEEE Directive info. p.v
Corrections p.i, 2-8 to 2-10, 2-12, 2-14, 2-15, 3-10, 3-12, 4-3, 4-4, 4-7, 5-1, 5-3, 5-5, 5-6, 5-12, 5-15, 5-22, 5-23, 5-27, 5-28, 5-30 to 5-41, 7-2
- 5th Feb. 2016**
Page 5-2, Section 5.2, "Overview of display and operation panels": Changed of figure 5.2.
Page 5-5, Section 5.3, "Outline of display screen" (3): Changed of table.
Page 6-40, Section 6.9.1, "Zero calibration": Changed of attached figure.
Page 6-41, Section 6.9.2, "Span Calibration": Changed of attached figure.
Page 8-2, Section 8.1, "Error message" In case of Error No. 5 and No. 7: Changed of attached figure.
Page 9-2, Section 9.1, "General Specifications," Changed the dimensions of the input/output terminal module.
Page 9-3, Section 9.1, "General Specifications,": Modify description of the safety and EMC conforming standards.
Page 9-10, Section 9.2, "Model and Suffix codes" Table 9-2 Double-component analyzer (NO-SO₂): Changed of the table 9-2.
Page 9-11, Section 9.2, "Model and Suffix codes" Measurable component and range - availability check table -: Changed the writing of the table 9.7.
Page 9-15, Section 9.3, "External Dimensions," Dedicated Zirconia O₂ Sensor: Modify description of the safety and EMC conforming standards.
Page 9-16, Section 9.3, "External Dimensions," External Dimensions of ZX8D: Change of figure.
Page 9-18, Section 9.3, "External Dimensions," NO₂/NO Converter: Modify description of the safety conforming standards.
- 4th Jun. 2012**
p.iv, "CAUTION ON SAFETY" Others: Addition of the description.
Addition of the "Notes on Use in Korea".
p.v, Changed the description of the "After-Sales Warranty".
p.6-38, Section 6.8, "Description of each setting": Addition of the "default value".
p.9-1, Section 9.1, "General specifications" Safety and EMC conforming standards: Addition of the "CAUTION".
p.9-5, Section 9.2, "Model and Suffix codes" Table: Addition of the "W (0-300 ppm)".
p.9-8, Section 9.2, "Model and Suffix codes" Table 1: Addition of the "W (0-300 ppm)".
p.9-13, Section 9.3, "External Dimension" STANDARD ACCESSORIES: Changed the rating level of the fuse (K9218SB).
p.9-18 Section 9.3, "NO₂/NO Converter" Replacement cycle: Changed of the description.
- 3rd Aug. 2007**
5.4 "General operation": Partially changed the figure.
6.2 "Calibration setting": Partially changed the figure and descriptions in "Setting range of values."
6.4.1 "Auto calibration": Partially changed the figure and descriptions in Caution.
6.4.2 "Execution of auto calibration": Partially changed descriptions in (3) ;

-
- 6.5.1 “Forced stop of auto calibration”: Partially changed descriptions in (3).;
 - 6.5.1 “Auto zero calibration”: Partially changed descriptions in Caution.;
 - 6.5.2 “Forced run/stop of auto zero calibration”: Partially changed descriptions in (3).;
 - 6.6 “Forced stop of auto zero calibration”: Partially changed descriptions in (3).;
 - 6.6 “Peak alarm setting”: Partially changed the figure and descriptions.
 - 6.9.1 “Zero calibration”: Partially changed the figure and descriptions in Caution.;
 - 6.9.2 “Span calibration”: Partially changed the figure.
 - 9.1 “General specifications,” Safety and EMC conforming standards: Changed descriptions and added Note.;
 - 9.2 “Model and Suffix code”: Deleted Footnote 8 and changed descriptions of Footnote 8 (former 9).
 - 9.3 “External Dimensions”: Changed power supply specification of NO₂/NO converter.;
 - 9.3 “External Dimensions,” NO₂/NO Converter: Changed “Part number” descriptions, added “Safety conforming standards” descriptions, deleted “CE Marking” descriptions, and changed “External Dimensions” drawings,

2nd Aug. 2006

Fully revised due to style change to S3

P. v., Added “After-Sales Warranty”

- 2.1 “Name and description of main unit”: Changed drawing partly;
- 3.4 “Piping”: Changed drawing partly;
- 3.4.7 “Example configuration of gas sampling system”: Changed drawing;
- 5.1 “Name and description of operation panel”: Changed drawing partly;
- 9.1 “Standard specifications”: Changed table “Measurable component and measurement range”;
- 9.1.5 “Standard Requirements for Sample Gas”: Changed description
- 9.2 “Model and Suffix codes”: Changed table partly;
- 9.2 “Measurable component and range 2 availability check table 2 “: (4);
- 9.2 “Double-component analyzer”: Changed table partly

1st Oct. 2002 Newly published

Yokogawa Electric Corporation
 2-9-32 Nakacho, Musashino-shi, Tokyo 180-8750, JAPAN
<http://www.yokogawa.com/>
